



## E-087 HV Systems for Hydroelectric Power Plants

Instructor: J Paul Guyer, P.E., R.A.

Course ID: E-087

PDH Hours: 2 PDH

# An Introduction to High Voltage Systems for Hydroelectric Power Plants



J. Paul Guyer, P.E., R.A.  
Editor

Paul Guyer is a registered civil engineer, mechanical engineer, fire protection engineer and architect with 35 years of experience designing buildings and related infrastructure. For an additional 9 years he was a principal staff advisor to the California Legislature on capital outlay and infrastructure issues. He is a graduate of Stanford University and has held numerous national, state and local offices with the American Society of Civil Engineers, Architectural Engineering Institute and National Society of Professional Engineers. He is a Fellow of ASCE, AEI and CIBE (U.K.).

# An Introduction to High Voltage Systems for Hydroelectric Power Plants

J. Paul Guyer, P.E., R.A.

Editor

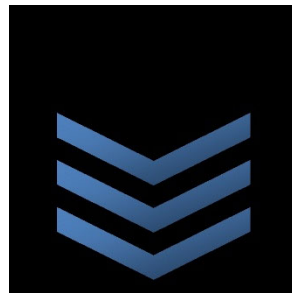

The Clubhouse Press  
El Macero, California

## CONTENTS

- 1. POWER TRANSFORMERS**
- 2. ELECTRICAL CHARACTERISTICS**
- 3. HIGH VOLTAGE SYSTEM**

(This publication is adapted from the *Unified Facilities Criteria* of the United States government which are in the public domain, have been authorized for unlimited distribution, and are not copyrighted.)

## **1. POWER TRANSFORMERS**

### **1.1 GENERAL**

**1.1.1 TYPE.** Step-up transformers for use with main units should be of the oil immersed type for outdoor operation, with a cooling system, suited to the location.

**1.1.2 THREE-PHASE TRANSFORMERS.** In the majority of applications, three-phase transformers should be used for generator step-up (GSU) applications for the following reasons: (1) Higher efficiency than three single-phase units of equivalent capacity. (2) Smaller space requirements. (3) Lower installed cost. (4) Lower probability of failure when properly protected by surge arresters, thermal devices, and oil preservation systems. (5) Lower total weight. (6) Reduction in weights and dimensions making larger capacities available within practical weight and size limitations.

**1.1.3 EHV APPLICATIONS.** In applications involving interconnection to EHV (345 kV and above) systems, reliability and application considerations dictate the use of single-phase units due to lack of satisfactory industry experience with three-phase EHV GSU transformers.

**1.1.4 TRANSFORMER FEATURES.** Regardless of winding configuration, for any given voltage and kVA rating, with normal temperature rise, the following features should be analyzed for their effect on transformer life cycle costs: (1) Type of cooling. (2) Insulation level of high-voltage winding. (3) Departure from normal design impedance.

**1.1.5 TRANSFORMER CONSTRUCTION.** There are two types of construction used for GSU transformers. These are the core form type and the shell form type. Core form transformers generally are supplied by manufacturers for lower voltage and lower MVA ratings. The core form unit is adaptable to a wide range of design parameters, is economical to manufacture, but generally has a low kVA-to-weight ratio. Typical HV

ranges are 230 kV and less and 75 MVA and less. Shell form transformers have a high kVA-to-weight ratio and find favor on EHV and high MVA applications. They have better short-circuit strength characteristics, are less immune to transit damage, but have a more labor-intensive manufacturing process. Both forms of construction are permitted by Corps' transformer guide specifications.

**1.2 RATING** The full load kVA rating of the step-up transformer should be at least equal to the maximum kVA rating of the generator or generators with which they are associated. Where transformers with auxiliary cooling facilities have dual or triple kVA ratings, the maximum transformer rating should match the maximum generator rating.

### **1.3 COOLING**

**1.3.1 GENERAL.** The standard classes of transformer cooling systems are listed in Paragraph 5.1, IEEE C57.12.00. Transformers, when located at the powerhouse, should be sited so unrestricted ambient air circulation is allowed. The transformer rating is based on full use of the transformer cooling equipment.

**1.3.2 FORCED COOLING.** The use of forced-air cooling will increase the continuous self-cooled rating of the transformer 15 percent for transformers rated 2499 kVA and below, 25 percent for single-phase transformers rated 2500 to 9999 kVA and three-phase transformers rated 2500 to 11999 kVA, and 33-1/3 percent for single-phase transformers rated 10000 kVA and above and three-phase transformers rated 12000 kVA and above. High-velocity fans on the largest size groups will increase the self-cooled rating 66-2/3 percent. Forced-oil cooled transformers, whenever energized, must be operated with the circulating oil pumps operating. Forced-oil transformers with air coolers do not have a self-cooled rating without air-cooling equipment in operation unless they are special units with a "triple rating."

**1.4 TEMPERATURE CONSIDERATIONS.** In determining the transformer rating, consideration should be given to the temperature conditions at the point of installation.

High ambient temperatures may necessitate increasing the transformer rating in order to keep the winding temperature within permissible limits. If the temperatures will exceed those specified under "Service Conditions" in IEEE C57.12.00, a larger transformer may be required. IEEE C57.92 should be consulted in determining the rating required for overloads and high temperature conditions. d. Unusual requirements. Class OA/FA and Class FOA meet all the usual requirements for transformers located in hydro plant switchyards. The use of triple rated transformers such as Class OA/FA/FA is seldom required unless the particular installation services a load with a recurring short time peak.

**1.5 CLASS FOA TRANSFORMERS.** On Class FOA transformers, there are certain considerations regarding static electrification (build-up of charge on the transformer windings due to oil flow). Transformer suppliers require oil pump operation whenever an FOA transformer is energized. Static electrification is important to consider when designing the desired operation of the cooling, and can result in the following cooling considerations: (1) Decrease in oil flow velocity requirements (for forced-oil cooled units). (2) Modifying of cooling equipment controls to have pumps come on in stages. (3) Operation of pumps prior to energizing transformer.

## **2. ELECTRICAL CHARACTERISTICS**

### **2.1 VOLTAGE.**

**2.1.1 VOLTAGE RATINGS** and ratios should conform to ANSI C84.1 preferred ratings wherever possible. The high-voltage rating should be suitable for the voltage of the transmission system to which it will be connected, with proper consideration for increases in transmission voltage that may be planned for the near future. In some cases this may warrant the construction of high-voltage windings for series or parallel operation, with bushings for the higher voltage, or windings suitable for the higher voltage tapped for the present operating voltage.

**2.1.2 CONSIDERATION** should also be given to the voltage rating specified for the low-voltage winding. For plants connected to EHV systems, the low-voltage winding rating should match the generator voltage rating to optimally match the generator's reactive capability in "bucking" the transmission line voltage. For 230-kV transmission systems and below, the transformer low voltage rating should be 5 percent below the generator voltage rating to optimally match the generator's reactive capability when "boosting" transmission line voltage. IEEE C57.116 and EPRI EL-5036, Volume 2, provide further guidance on considerations in evaluating suitable voltage ratings for the GSU transformer.

### **2.2 HIGH-VOLTAGE BIL.**

**2.2.1 BASIC IMPULSE INSULATION LEVELS (BIL)** associated with the nominal transmission system voltage are shown in Table 1 of IEEE C57.12.14. With the advent of metal oxide surge arresters, significant economic savings can be made in the procurement of power transformers by specifying reduced BIL levels in conjunction with the application of the appropriate metal oxide arrester for transformer surge protection. To determine appropriate values, an insulation coordination study should be made.



Studies involve coordinating and determining adequate protective margins for the following transformer insulation characteristics:

#### **2.2.1.1 CHOPPED-WAVE WITHSTAND (CWW).**

#### **2.2.1.2 BASIC IMPULSE INSULATION LEVEL (BIL).**

#### **2.2.1.3 SWITCHING SURGE LEVEL (SSL).**

**2.2.2 IF THERE IS REASON TO** believe the transmission system presently operating with solidly grounded neutrals may be equipped with regulating transformers or neutral reactors in the future, the neutral insulation level should be specified to agree with Table 7 of IEEE C57.12.00.

#### **2.2.3 IMPEDANCE.**

**2.2.3.1 IMPEDANCE OF THE TRANSFORMERS** has a material effect on system stability, short-circuit currents, and transmission line regulation, and it is usually desirable to keep the impedance at the lower limit of normal impedance design values. Table 4-1 illustrates the range of values available in a normal two-winding transformer design (values shown are for GSU transformers with

NOMINAL SYSTEM kV	WINDING BIL kV	CLASS OA, OR SELF-COOLED RATING OF CLASS OA/FA OR CLASS OA/FA/FA		CLASS FOA OR CLASS FOW	
		MINIMUM	MAXIMUM	MINIMUM	MAXIMUM
15	110	5.0	7.5	8.34	12.5
25	150	5.0	7.5	8.34	12.5
34.5	200	5.25	8.0	8.75	14.33
46	250	5.60	8.4	9.34	14.0
69	350	6.1	9.15	10.17	15.25
115	450	5.9	8.85	9.84	14.75
138	550	6.4	9.6	10.67	16.0
161	650	6.9	10.35	11.50	17.25
230	825	7.5	11.25	12.5	18.75
500	1425	10.95	15.6	18.25	26.0

Table 4-1

Nominal Design Impedance Limits for Power Transformers Standard Impedance Limits  
(Percent)

13.8-kV low voltage). Impedances within the limits shown are furnished at no increase in transformer cost. Transformers can be furnished with lower or higher values of impedance at an increase in cost. The approximate effect of higher- or lower-than-normal impedances on the cost of transformers is given in Table 4-2. The value of transformer impedance should be determined giving consideration to impacts on selection of the interrupting capacities of station breakers and on the ability of the generators to aid in regulating transmission line voltage. Transformer impedances should be selected based on system and plant fault study results. Impedances shown are subject to a tolerance of plus or minus 7.5 percent. (See IEEE C57.12.00).

**2.2.3.2 IN MAKING COMPARISONS** or specifying the value of impedance of transformers, care should be taken to place all transformers on a common basis. Impedance of a transformer is a direct function of its rating, and when a transformer has more than one different rating, it has a different impedance for each rating. For example, to obtain the impedance of a forced-air-cooled transformer at the forced-air-cooled rating when the impedance at its self-cooled rating is given, it is necessary to

multiply the impedance for the self-cooled rating by the ratio of the forced-air-cooled rating to the self-cooled rating.

STANDARD IMPEDANCE X	INCREASE IN TRANSFORMER COST
1.45-1.41	3%
1.40-1.36	2%
1.35-1.31	1%
0.90-0.86	2%
0.85-0.81	4%
0.80-0.76	6%

Table 4-2

Increase In Transformer Cost For Impedances Above and Below The Standard Values

**2.2.4 TRANSFORMER EFFICIENCY.** Transformer losses represent a considerable economic loss over the life of the power plant. A study should be made to select minimum allowable efficiencies for purposes of bidding. Included in the study should be a determination of the present worth cost of transformer losses. This value is used in evaluating transformer bids that specify efficiency values that exceed the minimum acceptable value. Examples of typical studies are included in Appendix B of this manual. IEEE C57.120 provides further guidance on transformer loss evaluation.

**2.2.5 TERMINALS.** Where low-voltage leads between the transformer and generator are of the metal-enclosed type, it is desirable to extend the lead housing to include the low-voltage terminals of the transformer. This arrangement should be indicated on the specification drawings and included in the specifications in order that the manufacturer will coordinate his transformer top details with the design of the housing. It is sometimes preferable to have the transformer builder furnish the housing over the low-voltage bushings if it simplifies the coordination. All bushing 4-3 EM 1110-2-3006 30 Jun 94 characteristics should conform to the requirements of IEEE C57.19.01. The voltage

rating should correspond to the insulation level of the associated winding. Where transformers are installed at elevations of more than 3,300 ft above sea level, bushings of the next higher voltage classification may be required. Bushings for neutral connections should be selected to suit the insulation level of the neutral.

## **2.2.6 ACCESSORIES**

**2.2.6.1 OIL PRESERVATION SYSTEMS.** Three different oil preservation systems are available, as described below. The first two systems are preferred for generator step-up transformers: (1) Inert gas pressure system. Positive nitrogen gas pressure is maintained in the space between the top of the oil and the tank cover from a cylinder or group of cylinders through a pressure-reducing valve. (2) Air-cell, constant-pressure, reservoir tank system. A system of one or more oil reservoirs, each containing an air cell arranged to prevent direct contact between the oil and the air. (3) Sealed tank. Gas is admitted to the space above the oil and the tank is sealed. Expansion tanks for the gas are provided on some sizes. Sealed tank construction is employed for 2,500 kVA and smaller sizes.

**2.2.6.2 OIL FLOW ALARM.** Transformers that depend upon pumped circulation of the oil for cooling should be equipped with devices that can be connected to sound an alarm, to prevent closing of the energizing power circuit, or to deenergize the transformer with loss of oil flow. In forced-oil-cooled units, hot spot detectors should be provided which can be connected to unload the transformer if the temperature exceeds that at which the second oil pump is expected to cut in. FOA transformers should employ control schemes to ensure pump operation prior to energizing the transformer.

**2.2.6.3 SURGE ARRESTERS.** Surge arresters are located near the transformer terminals to provide protection of the high-voltage windings. Normal practice is to provide brackets on the transformer case (230-kV HV and below) for mounting the selected surge arrester.

**2.2.6.4 FANS AND PUMPS.** The axial-flow fans provided for supplementary cooling on Class OA/FA transformers are equipped with special motors standardized for 115-V and 230-V single-phase or 208-V three-phase operation. Likewise, oil circulating pumps for FOA transformers are set up for single-phase AC service. Standard Corps of Engineers practice is to supply 480-V, three-phase power to the transformer and have the transformer manufacturer provide necessary conversion equipment.

**2.2.6.5 ON-LINE DISSOLVED GAS MONITORING SYSTEM.** The detection of certain gases, generated in an oil-filled transformer in service, is frequently the first available indication of possible malfunction that may eventually lead to the transformer failure if not corrected. The monitoring system can provide gas analysis of certain gases from gas spaces of a transformer. The system output contacts can be connected for an alarm or to unload the transformer if the gas levels exceed a set point. The type of gases generated, during the abnormal transformer conditions, is described in IEEE C57.104.

**2.2.6.6 TEMPERATURE DETECTORS.** A dial-type temperature indicating device with adjustable alarm contacts should be provided for oil temperature indication. Winding RTDs should be provided, and monitored by the plant control system or a stand-alone temperature recorder, if one is provided for the generator and turbine RTDs. At least two RTDs in each winding should be provided.

**2.2.6.7 LIFTING DEVICES.** If powerhouse cranes are to be used for transformer handling, the manufacturer's design of the lifting equipment should be carefully coordinated with the crane clearance and with the dimensions of the crane hooks. The lifting equipment should safely clear bushings when handling the completely assembled transformer, and should be properly designed to compensate for eccentric weight dispositions of the complete transformer with bushings.

**2.2.6.8 ON-LINE MONITORING SYSTEMS.** In addition to the on-line dissolved gas monitoring system, other on-line systems are available to monitor abnormal transformer conditions. These include: (1) Partial discharge analysis. (2) Acoustical monitoring. (3)

Fiber-optic winding temperature monitoring. (4) Bearing wear sensor (forced-oil-cooled units). (5) Load tap changer monitor (if load tap changers are used). Early detection of the potential for a condition leading to a forced outage of a critical transformer bank could more than offset the high initial costs of these transformer accessories by avoiding a more costly loss of generation.

**2.2.6.9 DIAL-TYPE INDICATING DEVICES.** Dial-type indicating devices should be provided for: (1) Liquid level indication. (2) Liquid temperature indicator. (3) Oil flow indicators (see paragraph 4-6b). These are in addition to the dial-type indicators that are part of the winding temperature systems.

**2.2.7 OIL CONTAINMENT SYSTEMS.** If any oil-filled transformers are used in the power plant, provisions are made to contain any oil leakage or spillage resulting from a ruptured tank or a broken drain valve. The volume of the containment should be sufficient to retain all of the oil in the transformer to prevent spillage into waterways or contamination of soil around the transformer foundations. Special provisions (oil-water separators, oil traps, etc.) must be made to allow for separation of oil spillage versus normal water runoff from storms, etc. IEEE 979 and 980 provide guidance on design considerations for oil containment systems.

## **2.2.8 FIRE SUPPRESSION SYSTEMS**

**2.2.8.1 GENERAL.** Fire suppression measures and protective equipment should be used if the plant's oil-filled transformers are located in close proximity to adjacent transformers, plant equipment, or power plant structures. Oil-filled transformers contain the largest amount of combustible material in the power plant and so require due consideration of their location and the use of fire suppression measures. Fires in transformers are caused primarily from breakdown of their insulation systems, although bushing failures and surge arrester failures can also be causes. With failure of the transformer's insulation system, internal arcing follows, creating rapid internal tank

pressures and possible tank rupture. With a tank rupture, a large volume of burning oil may be expelled over a large area, creating the possibility of an intense fire.

**2.2.8.2 SUPPRESSION MEASURES.** Suppression measures include the use of fire quenching pits or sumps filled with coarse rock surrounding the transformer foundation and physical separation of the transformer from adjacent equipment or structures. Physical separation in distance is also augmented by the use of fire-rated barriers or by fire-rated building wall construction when installation prevents maintaining minimum recommended separations. Economical plant arrangements generally result in less than recommended minimums between transformers and adjacent structures so water deluge systems are supplied as a fire prevention and suppression technique. The systems should be of the dry pipe type (to prevent freeze-up in cold weather) with the system deluge valves actuated either by thermostats, by manual break-glass stations near the transformer installation, or by the transformer differential protective relay.

### 3. HIGH-VOLTAGE SYSTEM

**3.1 DEFINITION** The high-voltage system as treated in this discussion includes all equipment and conductors that carry current at transmission line-voltage, with their insulators, supports, switching equipment, and protective devices. The system begins with the high-voltage terminals of the step-up power transformers and extends to the point where transmission lines are attached to the switchyard structure. High-voltage systems include those systems operating at 69 kV and above, although 34.5-kV and 46-kV systems that are subtransmission-voltage systems are also covered in this discussion. Transmission line corridors from the powerhouse to the switchyard should allow adequate clearance for maintenance equipment access, and clear working space. Working clearances shall be in accordance with the applicable sections of ANSI C2, Part 2.

### 3.2 SWITCHYARD

**3.2.1 SPACE AROUND THE SWITCHYARD.** Adequate space should be allowed to provide for extension of the switchyard facilities when generating units or transmission lines are added in the future. The immediate surroundings should permit the building of lines to the switchyard area from at least one direction without the need for heavy dead-end structures in the yard.

**3.2.2 SWITCHYARD LOCATION.** Subject to these criteria, the switchyard should be sited as near to the powerhouse as space permits, in order to minimize the length of control circuits and power feeders and also to enable use of service facilities located in the powerhouse. c. Switchyard fencing. A chain link woven wire fence not less than 7 ft high and topped with three strands of barbed wire slanting outward at a 45-deg angle, or concertina wire, with lockable gates, should be provided to enclose the entire yard.

**3 3 SWITCHING SCHEME.** The type of high-voltage switching scheme should be selected after a careful study of the flexibility and protection needed in the station for the



initial installation, and also when the station is developed to its probable maximum capacity. A detailed discussion of the advantages and disadvantages of various high-voltage switching schemes is included in this discussion.

**3.3.1 MINIMUM REQUIREMENTS.** The initial installation may require only the connecting of a single transformer bank to a single transmission line. In this case, one circuit breaker, one set of disconnects with grounding blades, and one bypass disconnecting switch should be adequate. The high-voltage circuit breaker may even be omitted under some conditions. The receiving utility generally establishes the system criteria that will dictate the need for a high side breaker.

**3.3.2 BUS STRUCTURE.** When another powerhouse unit or transmission line is added, some form of bus structure will be required. The original bus structure should be designed with the possibility of becoming a part of the ultimate arrangement. Better known arrangements are the main and transfer bus scheme, the ring bus scheme, the breaker-and-a-half scheme, and the double bus-double breaker scheme.

### **3.3.3 MAIN AND TRANSFER BUS SCHEME.**

**3.3.3.1 THE MAIN AND TRANSFER BUS SCHEME,** Figure 5a, consists of two independent buses, one of which is normally energized. Under normal conditions, all circuits are tied to the main bus. The transfer bus is used to provide service through the transfer bus tie breaker when it becomes necessary to remove a breaker from service.

**3.3.3.2 ADVANTAGES** of the main and transfer bus arrangement include: (a) Continuity of service and protection during breaker maintenance. (b) Ease of expansion. (c) Small land area requirements. (d) Low cost.

**3.3.3.3 DISADVANTAGES INCLUDE:** (a) Breaker failure or bus fault causes the loss of the entire station. (b) Bus tie breaker must have protection schemes to be able to substitute for all line breakers. (c) An additional tie breaker is required.

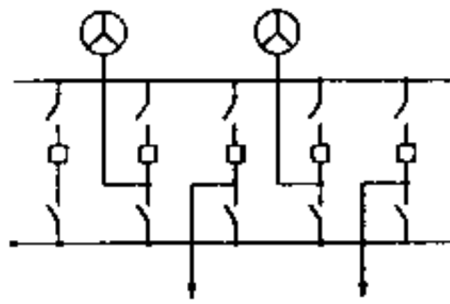

a. Main and transfer

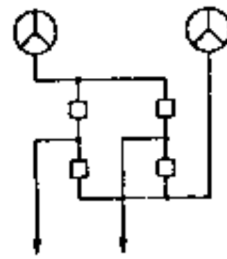

b. Ring bus

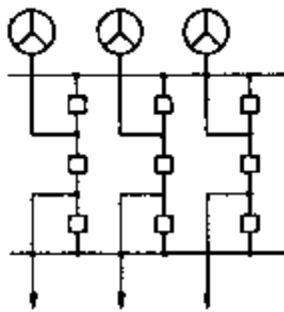

c. Breaker and a half

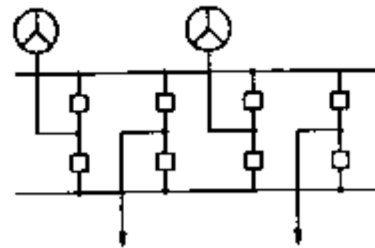

d. Double bus-double breaker

Figure 5-1  
Switchyard bus arrangements

### 3.3.4 RING BUS SCHEME.

**3.3.4.1 THE RING BUS**, Figure 5-1b, consists of a loop of bus work with each bus section separated by a breaker. Only limited bus sections and circuits can be removed from service in the event of a line or bus fault. A line fault results in the loss of the breakers on each side of the line, while a breaker failure will result in the removal of two bus sections from service. The ring bus arrangement allows for circuit breaker maintenance without interruption of service to any circuit.

**3.3.4.2 THE ADVANTAGES** of the ring bus scheme include: (a) Low cost (one breaker per line section). (b) High reliability and operational flexibility. (c) Continuity of service during breaker and bus maintenance. (d) Double feed to each circuit. (e) Expandable to breaker-and-a-half scheme.

**3.3.4.3 DISADVANTAGES INCLUDE:** (a) Each circuit must have its own potential source. (b) Usually limited to four circuits.

### **3.3.5 BREAKER-AND-A-HALF SCHEME.**

**3.3.5.1 THE BREAKER-AND-A-HALF ARRANGEMENT**, Figure 5-1c, provides for two main buses, both normally energized. Between the buses are three circuit breakers and two circuits. This arrangement allows for breaker maintenance without interruption of service. A fault on either bus will cause no circuit interruption. A breaker failure results in the loss of two circuits if a common breaker fails and only one circuit if an outside breaker fails.

**3.3.5.2 THE ADVANTAGES** of the breaker-and-a-half scheme include: (a) High reliability and operational flexibility. (b) Capability of isolating any circuit breaker or either main bus for maintenance without service interruption. (c) A bus fault does not interrupt service. (d) Double feed to each circuit. (e) All switching can be done with circuit breakers.

**3.3.5.3 THE DISADVANTAGES INCLUDE:** (a) Added cost of one half breaker for each circuit. (b) Protection and control schemes are more complex.

### **3.3.6 DOUBLE BUS-DOUBLE BREAKER SCHEME.**

**3.3.6.1 THE DOUBLE BUS-DOUBLE BREAKER ARRANGEMENT**, Figure 5-1d, consists of two main buses, both normally energized. Between the main buses are two breakers and one circuit. This arrangement allows for any breaker to be removed from service without interruption to service to its circuit. A fault on either main bus will cause no circuit outage. A breaker failure will result in the loss of only one circuit.

**3.3.6.2 THE ADVANTAGES** of the double bus-double breaker scheme include: (a) Very high reliability and operational flexibility. (b) Any breaker or either bus can be isolated without service interruption. (c) A bus fault does not interrupt service. (d) There is a double feed to each circuit. (e) All switching is done with circuit breakers. (f) Only one circuit is lost if a breaker fails.

**3.3.6.3 THE DISADVANTAGES** include the high cost of two breakers per circuit. g. Recommended scheme. The breaker-and-a-half scheme is generally recommended, as it provides flexibility and a reasonably simple method of providing full relay protection under emergency switching conditions. The number of sections (line “bays”) needed is dependent on the number of transmission lines and generation sources coming into the substation. The breaker-and-a-half scheme is normally designed and operated as a ring bus until system requirements dictate more than six breakers and six lines.

## **3.4 BUS STRUCTURES**

**3.4.1 ARRANGEMENTS.** The flat or low profile type of bus construction with pedestal-supported rigid buses and A-frame line towers is ordinarily the most economical where space and topography are favorable. Congested areas may require the use of a high, narrow steel structure and the use of short wire bus connections between disconnecting

switches and the buses. Switchyard layouts should provide adequate access for safe movement of maintenance equipment and the moving of future circuit breakers or other major items of equipment into position without de-energizing primary buses. Clearances to energized parts should, as a minimum, comply with ANSI C2, Section 12. Equipment access requirements should be based on the removal of high-voltage bushings, arresters, and conservators and radiators from large power transformers. b. Bus design criteria. The design of rigid bus systems is influenced by the following criteria: (1) Electrical considerations including corona and ampacity limitations. (2) Structural considerations including ice and wind loading, short-circuit forces, and seismic loads. The spacing of bus supports should limit bus sag under maximum loading to not greater than the diameter of the bus, or 1/150th of the span length. IEEE 605 provides further information on substation electrical, mechanical, and structural design considerations.

### **3.5 SWITCHYARD MATERIALS**

**3.5.1 GENERAL.** After design drawings showing a general layout of the switchyard and details of electrical interconnections have been prepared, a drawing should be made up to accompany the specifications for the purchase of the structures. This drawing should show the size, spacing, and location of principal members and the loadings imposed by electrical equipment and lines.

**3.5.2 STRUCTURE MATERIALS.** The following are four types of material most commonly used for substation structures: (1) Steel. Steel is the most commonly used material. Its availability and good structural characteristics make it economically attractive. Steel, however, must have adequate corrosion protection such as galvanizing or painting. Due to the maintenance associated with painting, galvanizing is generally preferred. Galvanized steel has an excellent service record in environments where the pH level is in the range of 5.4 through 9.6 (i.e., a slightly alkaline environment). Most industrial environments are in this pH range leading to the widespread use and excellent service record of galvanized steel structures. Because of the unbroken protective finish required, structures should not be designed to require field welding or

drilling. Adequate information to locate mounting holes, brackets, and other devices must be provided to the fabricator to allow all detail work to be completed before the protective finish is applied to the steel part. (2) Aluminum. In environments where the pH level is below 5.4 (i.e. an acidic environment, such as conditions existing in a brine mist), galvanized structures would give poor service. In these environments, consideration should be given to structures fabricated with aluminum members. Aluminum structures are satisfactory at other locations, if the installed cost is comparable to the cost of the equivalent design using galvanized steel members. Structures designed for aluminum are constructed of Alloy 6061-T6 and should be designed, fabricated, and erected in accordance with the Aluminum Association's specifications for aluminum structures.

**3.5.3 CONCRETE.** Pre-cast, pre-stressed concrete structures may be economical in some applications such as pull-off poles and switch structures. Care should be taken to avoid the use of detrimental additives, such as calcium chloride, to the concrete used in the structures. Due to the larger structural sizes and weights involved, special equipment may be required for concrete erection.

**3.5.4 WOOD.** Wood pole and timber structures may be economical for temporary structures or simple switch structures. Wood members must be treated with an appropriate preservative. Structural properties and size tolerances of wood are variable and must be considered during the design process.

**3.5.5 BUS MATERIALS.** The materials most commonly used for rigid and wire bus are aluminum and copper. Rigid bus fittings should be limited to bolted connections for copper, and welded connections on aluminum. Bus fittings for aluminum wire should be compression type. Either bolted or compression fittings are acceptable for use with copper wire bus.

## **3.6 TRANSFORMER LEADS**

**3.6.1 HIGH-VOLTAGE TERMINAL CONNECTIONS.** The connections between the high-voltage terminals of the transformer and the disconnect switch (or breaker) will usually be made with bare overhead conductors when the transformer is located in the switchyard. However, in cases where the transformer is in line with the axis of the disconnect, the connection between the disconnect terminals and the high-voltage bushing terminals can be made with suitably supported and formed rigid bus of the same type used in the rest of the switchyard. The fittings and interconnection systems between the high-voltage bus and the disconnect switches should be designed to accommodate conditions of frequent load cycling and minimal maintenance.

**3.6.2 OVERHEAD CONDUCTORS.** Bare overhead conductors from the transmission line termination to the high-voltage bushings can occasionally be used when the transformers are installed at the powerhouse, and overhead lines to the switchyard are used. An example of this would be when the transmission line is dead-ended to the face of the dam, and the transformer is located at the base of the dam near its face, and behind the powerhouse. However, locating the transformers at the powerhouse usually requires the use of high-voltage bus to the line termination when the line is terminated on a dead-end structure near the transformer.

**3.6.3 TEST TERMINALS.** To provide a safe and accurate method of transformer dielectric testing, accommodations should be made for easily isolating transformer bushings from the bus work. Double test terminals should be provided on transformer high-voltage and neutral bushings in accordance with Corps of Engineers practice. The design should provide adequate clearance from energized lines for personnel conducting the tests.

### **3.7 POWERHOUSE - SWITCHYARD POWER CONTROL AND SIGNAL LEADS**

**3.7.1 CABLE TUNNEL.** (1) A tunnel for power and control cables should be provided between the powerhouse and switchyard whenever practical. Use of a tunnel provides ready access to the cables, provides for easy maintenance and expansion, and offers

the easiest access for inspection. This tunnel should extend practically the full length of the switchyard for access to all of the switchyard equipment.

**3.7.2 THE CONTROL AND DATA** (non-signal) cables should be carried in trays in the tunnel, and continued in steel conduits from the trays to circuit breakers and other controlled equipment so as to eliminate the need for manholes and handholes. If there is a control house in the switchyard, it should be situated over the tunnel. The tunnel should be lighted and ventilated and provided with suitable drains, or sumps and pumps.

**3.7.3 IF THE GENERATOR LEADS**, transformer leads, or station service feeders are located in the tunnel, the amount of heat dissipated should be calculated and taken into consideration in providing tunnel ventilation. The power cables should be carefully segregated from the control and data acquisition cables to prevent electromagnetic interference, and to protect the other cables from damage resulting from power cable faults. If the tunnel lies below a possible high-water elevation, it should be designed to withstand uplift pressures.

**3.7.4 SIGNAL CABLES SHOULD** be physically separated from power and control circuits. If practical, the signal cable should be placed in cable trays separate from those used for either control or power cables. In no case should signal cables be run in conduit with either control or power cables. The physical separation is intended to reduce the coupling of electromagnetic interference into the signal cable from pulses in the (usually unshielded) control cables, or power system frequency energy from power cables. Even though the signal cable will be shielded, commercially available shielding does not provide 100 percent coverage or perfect shielding, and the separation is needed to reduce electrical noise superimposed on the signal.

**3.7.5 DUCT LINE.** For small installations having a limited amount of transforming and switching equipment, it may be desirable and economical to use duct lines instead of a cable tunnel for control and power cables. The duct system should use concrete



encased nonmetallic conduit, and manholes or handholes of adequate number and size should be provided. Separate ducts for the power cables and the control and data acquisition cables should be provided. At least 30 percent spare duct capacity should be provided for power cables, and 50 percent spare capacity provided for control and data acquisition cables. The manholes should be designed to drain unless costs are prohibitive.

### **3.7.6 HIGH-VOLTAGE BUS.**

**3.7.6.1 GENERAL.** There are three categories of high-voltage connection systems that find application in hydroelectric installations requiring high-voltage interconnection between the power plant and the switchyard or utility grid interconnection. These are as follows: (a) Oil or SF<sub>6</sub> gas-insulated cable with paper-insulated conductors. Cables commonly used for circuits above 69 kV consist of paper-insulated conductors pulled into a welded steel pipeline, which is filled with insulating oil or inert gas. The oil or gas in the pipe type construction is usually kept under about 200 psi pressure. These cables can safely be installed in the same tunnel between the powerhouse and the switchyard that is used for control cables. (b) Solid dielectric-insulated cable. Solid dielectric insulated cables are also available for systems above 69 kV. Their use may be considered, but careful evaluation of their reliability and performance record should be made. They offer advantages of ease of installation, elimination of oil or gas system maintenance, and lower cost. Their electrical characteristics should be considered in fault studies and stability studies. (c) SF<sub>6</sub> gas-insulated bus. An example of a typical installation is an underground power plant with a unit switching scheme and the GSU transformer located underground in the plant. A high-voltage interconnection is required through a cable shaft or tunnel to an aboveground on-site switchyard.

**3.7.6.2 DIRECT BURIAL.** While insulated cable of the type described can be directly buried, the practice is not recommended for hydroelectric plants because the incremental cost of a tunnel normally provided for control circuits and pipelines is moderate. In case of oil leaks or cable failure, the accessibility of the cable pipes in the

tunnel will speed repairs and could avoid considerable loss in revenue. Space for the location of cable terminal equipment should be carefully planned.

**3.7.6.3 BURIAL TRENCH.** If the power cables from the powerhouse to the switchyard must be buried directly in the earth, the burial trench must be in accordance with safety requirements, provide a firm, conforming base to lay the cable on, and provide protection over the cable. The cable must have an overall shield, which must be well-grounded, to protect, so far as possible, people who might accidentally penetrate the cable while digging in the burial area.

**3.7.6.4 SF6 GAS-INSULATED SYSTEMS.** SF6 gas-insulated systems offer the possibility of insulated bus and complete high-voltage switchyard systems in a compact space. Gas-insulated substation systems should be considered for underground power plant installations or any situation requiring a substation system in an extremely confined space. The design should accommodate the need for disassembly of each part of the system for maintenance or repair. The designer should also consider that the gas is inert, and in a confined space will displace oxygen and cause suffocation. After exposure to arcing, SF6 gas contains hazardous byproducts and special precautions are needed for evacuating the gas and making the equipment safe for normal maintenance work. SF6 gas pressure varies with temperature and will condense at low ambient temperatures. When SF6 equipment is exposed to low temperatures, heating must be provided. The manufacturer's recommendations must be followed. IEEE C37.123 provides guidance on application criteria for gas insulated substation systems.

## **3.8 CIRCUIT BREAKERS**

**3.8.1 INTERRUPTING CAPACITY.** The required interrupting rating of the circuit breakers is determined by short-circuit fault studies. In conducting the studies, conservative allowances should be made to accommodate ultimate system growth. If information of system capacity and characteristics is lacking, an infinite bus at the end 5-5 EM 1110-2-3006 30 Jun 94 of the transmission interconnection can be assumed.

Using an infinite bus will result in conservative values of fault kVA to be interrupted, and will probably not unduly influence the final result. ANSI C37.06 provides performance parameters of standard high-voltage breakers.

**3.8.2 DESIGN CONSIDERATIONS.** (1) Breakers for 69 kV and above generally are SF6 gas-insulated, with the dead tank design preferred for seismic considerations. The details of the relaying will determine the number of CTs required, but two CTs per pole should generally be the minimum. Three CTs may be required for the more complex switching arrangements, such as the breaker-and-a-half scheme. (2) At 230 kV and above, two trip coils are preferred. The integrity of the tripping circuit(s) should be monitored and if remotely controlled, the status should be telemetered to the control point. The gas system of SF6 breakers should be monitored since loss of SF6 gas or low gas pressure blocks breaker operation. (3) Breaker auxiliary “a” and “b” switch contacts are used extensively to initiate and block the operation of backup relaying schemes. As breakers are added, and protection added to cover new system contingencies, the protective relay schemes become more complex. To accommodate these situations, breakers should be purchased with at least eight “a” and eight “b” spare auxiliary contacts. (4) Layout of the substation should consider access required for maintenance equipment, as well as horizontal and vertical electrical clearance for the switches in all normal operating positions. (5) Specifications prepared for outdoor applications of SF6 power circuit breakers should provide the expected ambient operating temperature ranges so the breaker manufacturer can provide adequate heating to ensure proper operation of the breaker through the ambient operating range. Minimum standard operating ambient for SF6 equipment is -30 °C (IEEE Standard C37.122).

## **3.9 DISCONNECT SWITCHES**

**3.9.1 DISCONNECT OPERATORS.** Manual or motor-operated gang-operated disconnect switches should be provided for isolating all circuit breakers. For operating voltages of 230 kV or greater, or for remotely operated disconnects, the disconnects

should be motor operated. In some cases, depending on the switching scheme and substation layout, one or both of the buses will be sectionalized by disconnects. The sectionalizing disconnect switches may be either manual or motor-operated, depending on their voltage rating and the requirements of station design. The manual operating mechanism for heavy, high-voltage disconnects should preferably be of the worm gear, crank operated type.

**3.9.2 REMOTELY OPERATED DISCONNECTS.** Remotely operated disconnect switches should be installed only as line or breaker disconnects. Use of a remotely operated disconnect switch to serve as generator disconnect is strongly discouraged. Operation of generator disconnects should require visual verification (through operator presence) of the open position and a lockable open position to prevent the possibility of misoperation or misindication by reconnecting an out-of-service generator to an energized line.

**3.9.3 DISCONNECT FEATURES.** All disconnect switches should be equipped with arcing horns. The disconnect switch on the line side of the line circuit breakers should be equipped with grounding blades and mechanically interlocked operating gear. At 230 kV and above, line and generator disconnect switches should be of the rotating insulator, vertical break type, with medium- or highpressure contacts. Circuit breaker isolation switches may be either a two-insulator “V” or a side break type. Both the contacts and the blade hinge mechanism should be designed and tested to operate satisfactorily under severe ice conditions. At 345 kV and 500 kV, vertical break disconnects are preferred since they allow for reduced phase spacing and installation of surge suppression resistors. Each switch pole should have a separate motor operator.

## **3.10 SURGE ARRESTERS**

**3.10.1 PREFERRED ARRESTER TYPES.** Surge arresters should be of the station type (preferably a metal oxide type) that provides the greatest protective margins to generating station equipment.

**3.10.2 ARRESTER LOCATION.** Arresters should be located immediately adjacent to the transformers, if the connection between the transformers and switching equipment is made by overhead lines. If high-voltage cable is used for this connection, the arresters should be placed both near the switchyard terminals of the cable and adjacent to the transformer terminals. Arrester connections should be designed to accommodate removal of the arrester without removing the main bus connection to the high-voltage bushing. Location of arresters should be in accordance with IEEE C62.2.

**3.10.3 ARRESTER PROTECTION.** In all cases, enough space should be allowed between arresters and other equipment to prevent damage if the arresters should fail. If arresters are located where they form a hazard to operating personnel, they should be suitably enclosed. This can generally be accomplished with a woven wire fence provided with a lockable gate. The design of the enclosure should consider the clearance requirements for the switchyard operating voltage.

**3.10.4 ARRESTER VOLTAGE RATING.** The voltage rating of the arresters should be selected to provide a reasonable margin between the breakdown voltage of the arrester and the basic impulse insulation level (BIL) of the equipment protected. The rating, in the majority of cases, should be the lowest satisfactory voltage for the system to which the arresters are connected.

### **3.10.5 GROUNDED-NEUTRAL ARRESTERS.**

**3.10.5.1 IN APPLYING GROUNDED-NEUTRAL RATED ARRESTERS,** the designer should consider whether, under all conditions of operation, the system characteristics will permit their use. Grounded-neutral arresters should not be used unless one of the following conditions will exist: (a) The system neutral will be connected to the system ground through a copper grounding conductor of adequate size (solidly grounded) at every source of supply of short-circuit current. (b) The system neutral is solidly grounded or is grounded through reactors at a sufficient number of the sources of

supply of short-circuit current so the ratio of the fundamental-frequency zero-sequence reactance,  $X_0$ , to the positive sequence reactance,  $X_1$ , as viewed from the point of fault, lies between values of 0 and 3.0 for a ground fault to any location in the system, and for any condition of operation. The ratio of the zero-sequence resistance,  $R_0$ , to the positive sequence reactance,  $X_1$ , as viewed from the ground fault at any location, should be less than 1.0. The arrester should have suitable characteristics so that it will not discharge during voltage rises caused by switching surges or fault conditions.

**3.10.5.2 CONSIDERATION SHOULD BE GIVEN** to the protection of transmission line equipment that may be located between the arresters and the incoming transmission line entrance to the substation. In cases where the amount of equipment is extensive or the distance is substantial, it will probably be desirable to provide additional protection on the incoming transmission line, such as spark gaps or arresters.

**3.10.5.3 IF THE STATION TRANSFORMERS** are constructed with the high-voltage neutral connection terminated on an external (H0) bushing, a surge arrester should be applied to the bushing.