

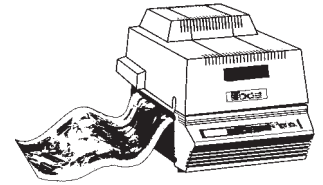

SECTION E: GRAPHICS





GERBER EDGE AND EDGE II DIGITAL IMAGING SYSTEMS

The Gerber Edge and Edge II is a revolutionary graphics output device that permanently fuses high-resolution images to 15" (381 mm) precision punched, Edge Ready vinyls and films. Through the use of the Edge and Edge II with an Edge compatible plotter, multiple-color jobs, halftones, airbrush-effects, fade and intricate text, become as simple as printing the complex portion and contour cutting around the outside edge.

The Gerber Edge is the only digital imaging system that offers:

- Output that's outdoor durable and ready to apply
- Cut any shape around any printed image with a Gerber 15" Edge-compatible plotter
- Print on a wide variety of Edge Ready materials
- Continuous length printing and automatic paneling of large images
- A growing array of GerberColor foils, including many spot, medal, transparents, finishing, fluorescents plus four-color process printing to use in any combination
- Proven in production environments worldwide

Additional benefits include:

- Gerber Edge graphics are printed dry and are outdoor durable for three to five years without lamination or any post-printing processes
- Print menu boards full of text in minutes onto removable vinyl
- Prints directly onto dozens of Edge Ready vinyls and other specialty materials
- Use spot color printing to create decals with a custom cut around the outside
- After Gerber Edge graphics are printed, graphics can be cut on any Gerber Edge-compatible, 15" sprocketed plotter
- Add a blast of photography to an otherwise dull sign, using Gerber Edge process color printing
- Simulate traditional airbrush and beveled effects by printing spot colors onto colored vinyls; more than 50 GerberColor foil cartridge colors are currently available
- Use GerberColor Spectratone to create thousands of solid, rich colors. Perfect for matching corporate and other specified colors
- Use the same file to add a logo to a delivery van or to generate palm-sized decals and create small, medium and large graphics with the automatic paneling capability
- The Gerber Edge has been in use for years and is backed by Gerber

The Gerber Edge 2 continues the Gerber Edge revolution with everything one could expect from the classic Gerber Edge, only better. It has all the same features as the Gerber Edge, but with these new additional improvements:

- Print speed up to three times faster
- Improved pixel placement through the use of advanced thermal management techniques and finely tuned Edge Ready materials and GerberColor foil settings
- User selectable 600 X 300dpi print mode creates sharper edge definition and more colors. (Print speed decreases in this mode)
- Prints onto all Edge Ready materials
- Prints with all GerberColor and Gerber ColorSet foil cartridges
- 20" per minute per color print speed, 95 sq. ft. of printing per hour for one-color printing, 22 sq. ft. per hour for four-color printing
- 11.8" wide print width per pass. Larger images can be paneled with the Omega paneling feature
- Budget friendly, entry-level price

A Great Choice:

Whether the Gerber Edge 2 is chosen for its sheer performance and state-of-the-art transfer process control features or the Gerber Edge for its value and solid reputation, both feature versatility in depth. It's a trait with the Gerber Edge family.

Catalog Number	Description	Volts
P60067A	Gerber Edge	115
P70567A	Gerber Edge 2	110/115

GERBER EDGE ACCESSORIES

Catalog Number	Description
P50504A	Shielded Printer Cable, 15'
P66530B	Thermal Print Head Cleaning Card, 25/Box
P50099A	Lint-Free Cloth
P50508A	Power Cord
P50136B	Registration Eyepiece

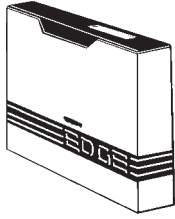

GERBERCOLOR EDGE CARTRIDGES

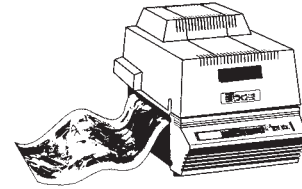

Gerber has spent many years perfecting a complete system of equipment and materials designed for the highest quality output. Gerber designed and developed the GerberColor™ foil series, which is an integral component of the Matched Technology System (MTS), designed to work with the Gerber Edge and Edge II. Gerber's dedication to the creation of the GerberColor™ foil series has brought to Edge owners more capabilities and features than anyone else; Color accuracy that brings process color Edge output to life, outstanding print quality on the widest array of substrates, superior halftones, gradient fills and the most complete foil coverage for color replication. Only Gerber provides the complete system of equipment, materials and unrivaled technical assistance which equals the Gerber Matched Technology System.

GERBERCOLOR SPOT • GCS SERIES

GerberColor™ Spot series foils are available in a wide range of smooth, consistent pigments that match popular vinyls, films, inks and paints. Ideal for both interior and exterior printed graphics, in commercial and industrial applications. Custom-formulated, resin-based, semi-gloss spot color foils will provide 3 to 5 years exterior life performance. 150' cartridge.

White, GCS-10	P49084A	Peacock Blue, GCS-77	P53527A
Black, GCS-12	P49085A	Olympic Blue, GCS-57	P49094A
Grey, GCS-31	P49086A	Intense Blue, GCS-47	P53497A
Brown, GCS-19	P49087A	Cobalt Blue, GCS-37	P49093A
Beige, GCS-49	P53512A	Aqua, GCS-176	P53542A
Lemon Yellow, GCS-155	P53537A	Teal, GCS-96	P53507A
Yellow, GCS-15	P49088A	Green, GCS-186	P49095A
Sunflower Yellow, GCS-625	P53502A	Kelly Green, GCS-46	P60362A
Kumquat, GCS-74	P53532A	Forest Green, GCS-66	P53492A
Orange, GCS-14	P49089A	Abrasion Guard, GCS-114	P55151A
Pink, GCS-643	P53522A	Navy, GCS-627	P60382A
Tomato Red, GCS-13	P49090A	Tan, GCS-39	P60372A
Ruby Red, GCS-53	P49091A	Raspberry, GCS-133	P60377A
Brick Red, GCS-603	P60367A	Imitation Gold, GCS-105	P66272A
Burgundy, GCS-58	P53487A	Terra Cotta, GCS-24	P66264A
Light Purple, GCS-668	P53517A	Intense Red, GCS-663	P66268A
Purple, GCS-38	P49092A	Raspberry, GCS-133	P60377A
Light Grey, GCS-681	P66252A	Navy, GCS-627	P60382A
Dark Grey, GCS-641	P66256A	Apple Green, GCS-196	P66276A
Tan, GCS-39	P60372A	Dark Green, GCS-56	P66260A
Royal Reflex, GCS-687	GCS687		

GERBERCOLOR METALLIC • GCS SERIES

Silver, GCS-620	P60387A	Copper, GCS-629	P66280A
Gold, GCS-631	P60392A	Champagne Gold, GCS-601	P66284A

GERBERCOLOR PROCESS • GCP SUPER CMYK SERIES

Turn logos, custom artwork, and photographs no matter how complex into highly profitable, outdoor-durable graphics of exceptional quality. These specially formulated foils were developed in conjunction with the Super CMYK formula, GA Premier software and the Edge system to produce accurate four-color reproductions as well as process color simulations of solid Pantone® Colors. 150' cartridge.

Process Yellow, GCP-705	P65402A	Process Cyan, GCP-707	P65404A
Process Magenta, GCP-773	P65403A	Process Black, GCP-712	P65405A

GERBERCOLOR MEDAL • GCM SERIES

Adds a polished metallized finish to signs, labels and decals. Recommended for indoor use only. GerberColor™ Medal Series foils can be overprinted on top of GerberColor™ spot, process or transparent foils for additional impressive effects. 84' cartridge.

Silver Medal, GCP-720	P49097A	Gold Medal, GCP-731	P49096A
-----------------------	----------------	---------------------	----------------

GERBERCOLOR TRANSPARENT • GCT SERIES

Use as standard spot colors or blend together to obtain new color combinations. The greatest feature of the GerberColor™ Transparent Series is that these foils allow the characteristics of the Edge ready base materials to come through. 150' cartridge.

Red, GCT-643	P60407A	Blue, GCT-617	P60397A
Orange, GCT-614	P60402A	Green, GCT-116	P60452A
Tomato Red, GCT-13	P60422A	Brown, GCLT-629	P60447A
Burgundy, GCT-49	P60437A	Yellow, GCLT-625	P60417A
Plum Purple, GCT-128	P60432A	Gold, GCLT-105	P60442A
Sapphire Blue, GCT-37	P60427A		

GERBERCOLOR LT • GCLT SERIES

Used in conjunction with Gerber heat transfer paper, these spot and process GerberColor™ foils produce transferable graphics which are then heat press-applied to garments, textiles, caps and a wide variety of specialty items. 150' cartridge.

Process Yellow, GCLT-605	P59742A	Red, GCLT-613	P59727A
Process Magenta, GCLT-273	P59752A	Blue, GCLT-647	P59737A
Process Cyan, GCLT-607	P59757A	Green, GCLT-606	P59732A
Process Black, GCLT-12	P59747A		

GERBERCOLOR FINISHING • GCF SERIES FOILS

Abrasion Guard is designed for graphics likely to experience repeated handling. This clear topcoat makes Gerber Edge produced graphics more resistant to abrasion.

Matte Clear is designed to reduce the gloss level of Edge printed graphics by up to 60%. Enhances the readability of the resulting graphics in applications that require optimum clarity. 84' cartridge.

Abrasion Guard GCS-114	P55151A	Matte Clear GCS-334	P66870A
------------------------	----------------	---------------------	----------------

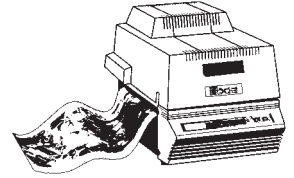

GERBER EDGE FONTS, LIBRARIES & ACCESSORIES

EDGE FONTS

Graphic fonts combined with computerized airbrushing, fades and other effects. These unique type treatments duplicate effects that previously could only be created by hand. Use alone or with other Vector Art. Fonts are serialized and require GA serial number and GSP system ID number.

Agenda Extra Bold	P52761A	Heritage	P50743A
Alloy	P54555A	Hyde Park Bold	P54891A
Alpha Medium ⁽²⁾	P50092A	Illusive	P55421A
Alumina Bold ⁽²⁾	P55425A	Jade	P57816A
Asiatic	P54556A	Jamaica Bold	P52762A
Blacksmith Bold	P56126A	Jasper	P60666A
Barnyard	P57820A	Liquid Crystal ⁽²⁾	P50084A
Beta	P57819A	Mercury Italic ⁽¹⁾	P63576A
Bubble Gum Script	P50083A	Millen	P50741A
Burgess Chrome ⁽²⁾	P56127A	Modula Roman	P50742A
Clearcut	P57813A	Morning Glory	P55420A
Classic Bold	P52759A	New Mosaic Bold	P56210A
Cyborg	P57675A	Sahara	P57818A
Distinction	P55423A	Showbiz	P60459A
Dropout	P52595A	Stovepipe ⁽²⁾	P54558A
Eurostile Bold Shadow ⁽²⁾	P50745A	Surge	P57814A
Fairway Compact	P55424A	Taverna	P52763A
Fleming	P56209A	Tolerant	P55419A
Fusion	P57379A	Twofold	P57815A
Gothic Black	P52764A	Yankee Doodle	P50740A
Gradual	P55418A	Zany Connected	P57216A
Festival	P69774A	Hot Chilies	P69780A
Lazydaze	P69776A	Stone	P69778A

EDGE LIBRARIES

Fonts are serialized and require GA serial number and GSP system ID number.

G-General Purpose Library	P52748A	G-Exit/Fire/No Smoking Library	P52749A
G-Architectural Library	P52750A	G-Traffic Mgmt./Handicap Library	P52751A
G-Point-of-Sale 1 Library	P52752A	G-Point-of-Sale 2 Library	P52753A
G-Caution Library	P52754A	G-Warning/Think Library	P52755A
G-Notice/Safety First Library	P52756A	G-Danger 1 Library	P52757A
G-Danger 2 Library	P52758A		

A small sample of enhanced fonts.



Agenda Extra Bold



Eurostile Bold Shadow



Yankee Doodle



Bubble Gum Script



Drop Out



Modula Roman

NOTE: ⁽¹⁾ Requires GA release 6.0 or higher.

⁽²⁾ Indicates Edge fonts included with GA Rev 6.2 and upgrades to GA 6.2



GERBER EDGE READY PRINTING MATERIALS



Gerber offers a wide range of materials, identified by the Edge Ready™ symbol, designed and approved for use in the Gerber Edge. Edge Ready™ printing materials can be found throughout this section.

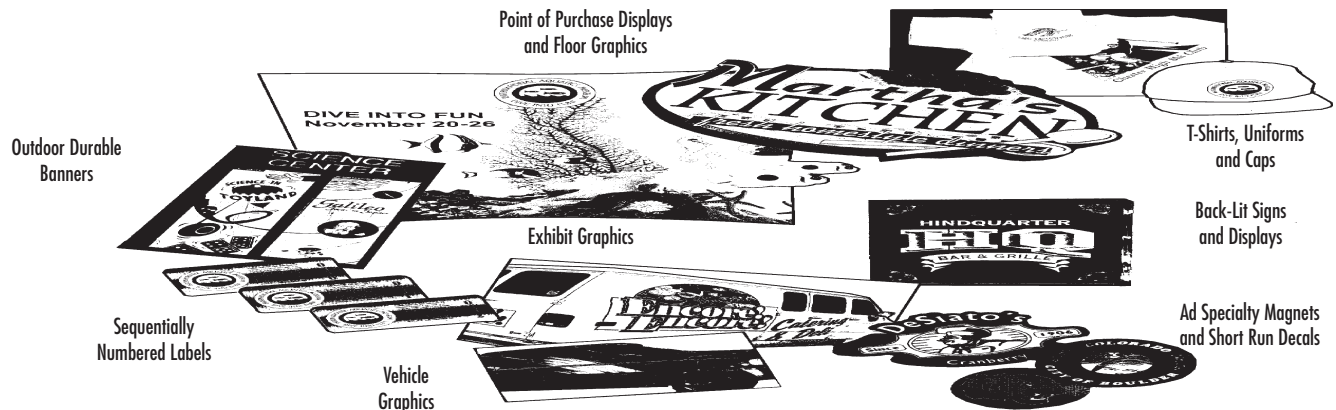

Commerce: 323.803.2000 / 800.225.5432 (CALL IEC) / Fax 323.803.2019

Las Vegas: 702.795.2233 / 800.772.4141 / Fax 702.798.9911 • Benicia: 707.747.5115 / 800.824.0099 / Fax 707.747.1266



GERBER ENVISION PLOTTER

World renowned Gerber enVision plotters are the ultimate in advanced sprocket-feed technology. Designed and built by Gerber, the enVision provides extreme accuracy in material tracking and alignment demanded by sign shops for long signs and unattended operation.

enVision 375:

The 15" Gerber enVision 375 plotter is the ultimate partner for cutting Gerber Edge and Edge 2 graphics with unsurpassed color-to-color and print-to-cut registration at lightning speed.

enVision 750:

The 30" Gerber enVision 750 plotter is the ideal solution for long signs, fleet graphics and other wide-format graphic applications.

Precise and Easy Material Loading:

Superior pin-feed system ensures that material loads quick and tracks with exacting precision for spectacular results. To make loading even easier, the enVision's "Advanced X-Axis Homing" feature brings the 3 pin setup to the original loading position at the touch of a key.

Pin-Feed Tracking for Extreme Accuracy:

Advanced bail/rollers system keeps even difficult to cut materials under complete control. Gerber enVision plotters have proven to perform so reliable unattended, the lengthy text or graphics can be run after hours to increase productivity.

Outstanding Performance:

At speeds up to 36" per second and 3G acceleration, the enVision ensures that even the most unwieldy jobs are precisely cut every time. The Gerber enVision is a great performer, powering through workloads, quickly and precisely.

High Performance Servo Drive:

Continuous, automatic system monitoring assures a precision cut at every position, at any velocity. With the enVision, the user is always in control and assured of maximum performance.

enVision Specifications:

- Material Width: enVision 375 - 15", enVision 750 - 30"
- Active Cutting Width: enVision 375 - 13.25", enVision 750 - 27.25"
- Maximum Media Thickness: .045"
- Drive Technology: Sprocket-Feed
- Cutting Technology: Swivel Knife
- Mechanical Resolution: 0.0002"
- Knife Options: 30, 45, 60 Degree
- Maximum On-Axis Speed: 36 ips
- Maximum Diagonal Speed: 50 ips
- Maximum Acceleration: 3G
- Knife Cycle Speed: 40 Up/Down Cycles/Second
- Cutting Pressure Range: 0.0 oz. - 16 oz.
- Interface: 250 Kilobytes
- Input Buffer: 250 Kilobytes
- Stand: enVision 375 - Desktop, enVision 750 - Standard
- Pounce: Optional Tool
- Dimension: enVision 375 - 29"L x 11"W x 14"H
enVision 750 - 38.5"L x 26"W x 48"H
- Weight: enVision 375 - 60 lbs, enVision 750 - 107 lbs
- Power Requirements: 100-230 Volts 47/63 Hz
- Software Command Set: GSP-GL or HP-GL2 Subset
- Vector Look Head and Curve & Arc Smoothing: Yes
- Test Plot and Cut Possibility: Yes
- Replot Function: Up to 9,999
- Pens: HP Compatible

Plotter Options:

Long Sign Material Catcher

Available for FasTrack models 650, 750, 1000 and 1300. Keeps material clean and collects cut off material.

Pounce tool:

Available for the Odyssey. Used for print models of Gerber enVision and FasTrack plotters and GS15^{plus} Plotters.

Illuminated Target Locator:

Available for the Odyssey. Used for point-to-cut target registration of Maxx graphics.

Plotter Stand:

Available for all models of FasTrack plotters. Assists with proper material tracking.



GERBER MAXX 2 DIGITAL IMAGING SYSTEM

Gerber's Maxx 2 is an unbelievably versatile and productive wide format thermal transfer printing system. It prints outdoor-durable, pigment-based spot and process colors direct to Maxx Ready materials like uncoated pressure-sensitive vinyl and a growing list of specialty substrates. Output is ready to use the moment the Maxx 2 has finished printing it with no need to laminate.

Gerber Maxx 2 is a 36" wide thermal transfer printer that offers unmatched options for the wide format digital printing market. It offers unattended operation with six cassette bays and automatic cassette switching. Cut large format graphics on Maxx compatible plotters, eliminating the tedious hand cutting process. Print with process color, spot color, GerberColor Spectratone solid, rich, spot colors. SmartFoil Technology determines if the wrong color foils are installed or if not enough foil is left to finish the job. With the same foil formulation as for the Gerber Edge, Maxx 2 offers proven durability and color selection. Print onto a wide and growing selection of Maxx Ready materials. Maxx 2 Intelligent Material Advance System allows for a variety of Maxx Ready material sizes and allows for unattended operation for long color registration. Create larger graphics with the automatic tiling capability.

Print & Cut:

Maxx 2 can contour cut output if needed without dies or hand cutting. Works with Gerber cutting plotters using a simple registration system to align materials. Plotter then contour cuts output without the need to hand cut or spend for costly dies.

Beyond Four Color:

Four color printers simulate the colors they print resulting in visible textures and halftone patterns. Maxx 2 on the other hand, works with real spot colors in addition to four color process, so it gives unmistakable, texture free, dyed-in-the-mass pop and explosive visual impact so important to increasingly discriminating buyers of signs, decals and thousands of other types of specialty graphics.

Clean, Quick and Easy:

Maxx Ready media and Maxx Color foils are designed to make life easy and make every job look great. There are no messy liquids, toners or other chemicals to handle or dispose of. Job set-up is fast and simple. Compare this with high maintenance requirements of other digital imaging systems and Maxx 2 looks even better.

Driven by Powerful Software:

Working with Gerber powerful Omega CP software, one can design for print and contour-cutting right on the computer screen. Changes can be made without impacting the cost of work produced, improving work flow and bottom line.

Work with Data from Other Sources:

Omega software works with a variety of file formats from other design and production systems as well. End users and trade customers alike can bring in designs that can be reproduced with Maxx 2 in the required size and quantity. With volume considerations a thing of the past and the technical confines blown away, Maxx 2 is a huge asset to anyone serving the needs of trade buyers. Repeat orders become simple.

Print Direct to Uncoated Vinyl:

Maxx 2 works with many of the material types commonly worked with such as Maxx Ready uncoated pressure-sensitive vinyl. Maxx 2 prints direct, transferring potent color to the surface of the target media and fusing it there. The results are stunning and durable. Maxx 2 output resists weather and temperature that leave other technologies in the shade. Use Maxx 2 output with confidence for vehicle graphics, outdoor advertising and anywhere a long term result is necessary.

Unattended Operation:

Up to six colors can be loaded into the Maxx 2 at one time. At the user's option, the four process colors can be loaded with space still available for two spot colors or practically any combination required from the extension range of Maxx Color imaging foils. If jobs involve more than six loaded colors, Maxx 2 prompts the operator to simply replace a cassette and the job is underway with minimum interruption. Once loaded with the required cassettes and the appropriate Maxx Ready media, operation is unattended. Productivity gets a further boost because Maxx 2 output needs no post-imaging processes like lamination or encapsulation to deliver outdoor durability. Fewer process steps mean less operator time per job, higher throughput and better profit opportunities.

Intelligent & Economical:

The incredible interplay of a precision, thermo controlled print head and unique Intelligent Materials Advance Systems (IMAS) enable Maxx 2 to build the images it prints in 4" wide passes, easily and efficiently. It intelligently manages and optimizes the use of Maxx Color Imaging Foils. Foil is not expended as the print head traverses speedily to non-print areas of the media. This saves time and money when printing borders and long stripes. Maxx 2 also moves media in both directions through the system, minimizing the time the system spends preparing the next cassette auto-change, therefore it does not rely on unrealistic, high physical print speeds in order to deliver it's impressive throughput.

Service Contract:

Maxx 2 service contracts purchased during the first year may be eligible for an additional discount. Call for details.

Catalog Number	Description
P75975A	Gerber Maxx 2, 220 Volts
P72966C	Cleaning Card, Gerber MaxxPrinthead (100 per box)
P72533A	Cassette Assembly



GERBER MAXX COLOR FOILS

Ever since introducing automated graphics and lettering to the industry well over a decade ago, Gerber has stood at the forefront of equipment and materials innovation. Today, the same company that set the standard for computer-based design and production systems has set a new standard for high performance foils via the Maxx Color Foil Series. Developed as part of Gerber's unique Matched Technology System, a complete portfolio of the highest quality materials and equipment in the industry, these time-tested and proven GerberColor foils are designed to deliver everything necessary.

Maxx Color Spot (MCS) Series:

Maxx Color Spot (MCS) Series foils are available in a wide range of smooth, consistent pigments that match popular vinyls, films, inks and paints. Ideal for both interior and exterior printed graphics. In commercial and industrial applications, foils can be used separately, in conjunction with process and transparent color foils or overprinted to create custom colors, patterns, fade and shade effects. Maxx Color Spot (MCS) Series foils are a cost-effective and time saving alternative to four-color process for one, two or three-color jobs and offer color matching that cannot be achieved with four-color processes.

Catalog Number	Color	Length (Feet)
P70638A	Black	1640
P70640A	Cobalt Blue	1640
P70647A	Gray	1640
P70645A	Green	1640
P70643A	Intense Blue	1640
P70646A	Olympic Blue	1640
P70648A	Orange	1640
P70642A	Ruby Red	1640
P70641A	Tomato Red	1640
P70644A	Yellow	1640
P70693A	Apple Green	328
P70696A	Aqua	328
P70658A	Beige	1640
P70656A	Brown	1640
P70650A	Burgundy	1640
P70706A	Champagne Gold	328
P70705A	Copper	328
P70662A	Dark Gray	1640
P70694A	Dark Green	328
P70649A	Forest Green	1640
P70757A	Intense Red	1640
P70655A	Kelly Green	1640
P70661A	Lemon Yellow	1640
P70697A	Light Purple	328
P70660A	Navy	1640
P70701A	Pink	328
P70654A	Purple	1640
P70652A	Sunflower Yellow	1640

Maxx Color Super CMYK:

Maxx Color Super CMYK Process (MCP) Series, was designed with the latest improvements in pigment and foil technologies for producing the most durable process color prints to date. These foils are the only thermal transfer foils in the industry recognized by Pantone® for process color simulations of solid Pantone® Colors. In addition, Super CMYK offers improved durability and expanded print definition.

Catalog Number	Color	Length (Feet)
P70637A	Super CMYK Process Black GCP-712	1640
P70636A	Super CMYK Process Cyan GCP-707	1640
P70635A	Super CMYK Process Magenta GCP-773	1640
P70634A	Super CMYK Process Yellow GCP-705	1640

Maxx Color Transparent (MCT) Series:

Maxx Color Transparent (MCT) Series foils offer expanded opportunities for the Maxx 2 user. Like the Maxx Color Spot (MCS) Series, MCT products are outdoor-durable, resin-based thermal transfer foils with the additional quality of being transparent. This unique transparent feature allows the characteristics of the base Maxx Ready material to come through and be enhanced. Reflectives reflect, metallics sparkle, chrome-finished films shine bright and transluents light up like never before. MCT foils can also be used on opaque films for traditional spot color applications. MCT Series foils are completely compatible with all Maxx Ready materials and Maxx Color foils.

Catalog Number	Color	Length (Feet)
MCT617-100	Transparent Blue	328
MCT629-100	Transparent Brown	328
MCT105-100	Transparent Gold	328
MCT116-100	Transparent Green	328
MCT643-100	Transparent Red	328
MCT37-100	Transparent Sapphire Blue	328
MCT13-100	Transparent Tomato Red	328
MCT625-100	Transparent Yellow	328

Maxx Winter White Foil:

Maxx Winter White foil can be used to place white output onto a colored background or to act as a primer for maintaining desired color output when printing onto a colored background. (ie: printing yellow text on a blue background)

MCS610-500

Maxx Color Finishing (MCF) Series:

Maxx Color Finishing (MCF) Series foil is designed to protect, enhance and add effects to Gerber Maxx 2 produced graphics. It is an Abrasion Guard and is a clear, semi-gloss, overprint foil that adds protection against moderate handling conditions.

MCF114-500



GERBER ODYSSEY PLOTTER

When it comes to precision and unparalleled performance, Gerber plotters are the benchmark against which all other plotters are measured. Whether a sign shop with an expanding business, a start-up looking for the best plotter to help business grow or an operation with highly focused niche applications, Gerber has a plotter to suit every situation. A choice of sprocket-feed, friction-feed and the newest GerberDrive plotters offering a range of media-width flexibility, tracking technologies and print-to-cut capabilities are available. The new Gerber Odyssey with GerberDrive is a breakthrough, first-of-its-kind cutting plotter that combines ultra-precise tracking with media-width flexibility. Providing the extreme accuracy in material tracking and alignment demanded by sign shops for long signs and unattended operation, the Gerber Odyssey offers the best of all worlds. Designed and built by Gerber, the Odyssey incorporates truly revolutionary technology designated GerberDrive, an entirely new active tracking technology. It works by detecting even the most minute movement in the material from the intended track. The moment any movement is detected, its unique sensing and active-tracking mechanism ensures the material is kept in line. It all happens automatically. It is Gerber technology at its best.

Automatic Material Alignment:

The Odyssey takes the guesswork out of lining up your material. Simply load material onto the plotter and material will align quickly and precisely, at the press of a key.

Active Tracking Control:

Odyssey continues to work while the job is running, ensuring that it tracks and cuts correctly the first time.

Exceptional Material Flexibility:

The Odyssey delivers first-class material utilization, giving the flexibility to cut to 49" wide. A wide range of material widths, rolls, sheets and even scraps from 4" up to 52" can be loaded. Plus cutting force is easily adjustable up to 16 ounces, allowing one to work with a large assortment of materials from lightweight masking films, to pressure-sensitive vinyls, to tough materials such as reflectives and sandblast stencils.

Outstanding Performance:

At speeds up to 36 inches per second and 3G acceleration, the Odyssey powers through even most demanding work loads. Also features automatic cut off and tool setting, material measurement routine, repeats up to 9,999, Gerber MAXX cutting solution and cut, pounce and pen functions.

Catalog Number	Description
P71803A	Gerber Odyssey 48" Plotter, 115 Volt
P63681B	30" Knife Blades, Set of 2
P63679B	45" Knife Blades, Set of 2
P63680B	60" Knife Blades, Set of 2
P67579A	Cable, PC to Plotter, 15'
P72400A	Cleaning Brush
P69653D	Cut-Off Mat, 48"
P68430B	Cutting Strip, 48"
P72100C	Illuminated Target Locator
P32945A	Material End Plug
P61643A	Pen, Rollerball Black, Set of 4
P61644A	Pen, Rollerball Blue, Set of 4
P61646A	Pen, Rollerball Green, Set of 4
P61645A	Pen, Rollerball Red, Set of 4
P72613A	Pounce Mat
P72482A	Pounce Mat & Tool Kit
P73828B	Pounce Tool
P67283B	Registration Eyepiece
P65916B	Swivel Knife Assembly w/45" Blade



GERBER MAXX READY MATERIALS

Maxx Ready materials are fully compatible with the Gerber Maxx 2. Additionally, every Gerber product is backed by Gerber on systems, materials and foils and is completely supported by a staff of knowledgeable professionals who truly understand how equipment and materials must work together to produce exceptional results.

"Maxx Ready" is the term used to identify Gerber's line of materials for a wide range of markets and applications that have been specifically designed and tested to provide optimal printing on the Gerber Maxx 2. "Image Ready" is the term used to identify Gerber's Digital Imaging Material and foils for a wide range of markets and applications. Image Ready materials and foils have been specifically designed, developed and manufactured to provide optimal results on Gerber Digital Imaging Systems.

Image Ready products are integral components of the Matched Technology System, taking the guesswork out of digital printing. Look for the Image Ready label for unsurpassed performance, confidence and success.

The Image Ready label encompasses all GerberColor, Gerber ColorSet, Edge Ready, Maxx Color and Maxx Ready materials and foils.

3M SCOTCHCAL SERIES 225 PREMIUM FILM NON-PERFORATED

Catalog Number	Description	Width	Length
P71364A	Maxx Ready White Film	36"	50 Yards
P71323A	Maxx Ready Clear Film	36"	10 Yards
P71365A	Maxx Ready Clear Film	36"	50 Yards

3M SCOTCHCAL SERIES 231 TRANSLUCENT FILM NON-PERFORATED

Catalog Number	Description	Width	Length
P73973A	Maxx Ready White Film	36"	10 Yards
P73974A	Maxx Ready White Film	36"	50 Yards

GERBER QUANTUM MARKING FILM NON-PERFORATED

Catalog Number	Description	Width	Length
P71384A	Series 4000 White Film	36"	50 Yards

3M SCOTCHCAL SERIES 281 REFLECTIVE SHEETING NON-PERFORATED

Catalog Number	Description	Width	Length
P74194A	Maxx Ready White Film	36"	25 Yards

3M CONTROLTAC 250C WITH COMPLY PERFORMANCE NON-PERFORATED

Catalog Number	Description	Width	Length
P71348A	White Film	36"	10 Yards
P71390A	White Film	36"	50 Yards

MAXX READY OVERLAMINATES UV GERBER GUARD NON-PERFORATED

Catalog Number	Description	Width	Length
P73547A	UVGuard Overlaminates	36"	10 Yards
P73548A	UVGuard Overlaminates	36"	50 Yards

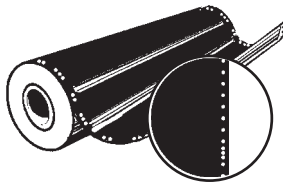

SERIES 220 PREMIUM 3M SCOTCHCAL FILM

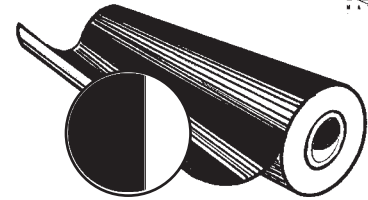

High performance 2 mil cast vinyl specifically developed for Gerber by 3M for optimal cutting, weeding and application. Clear pressure sensitive adhesive allows production of attractive two-way marking. Excellent durability with five-to-seven year exterior life. Other widths and colors also available.

Color	Perforated Rolls				Non-Perforated Rolls	
	15" x 10 yd	15" x 50 yd	30" x 10 yd	30" x 50 yd	30" x 10 yd	30" x 50 yd
Matte White	P20867C	P20868C	P21915C	P20959C	P58333A	P58433A
White	P20853C	P20854C	P21919C	P20963C	P58334A	P58434A
Matte Black	P20871C	P20872C	P21916C	P20960C	P58344A	P58444A
Black	P20855C	P20856C	P21918C	P20962C	P58345A	P58445A
Antique White	P53024A	P53044A	P53064A	P53084A	P58335A	P58435A
Eggshell	P53023A	P53043A	P53063A	P53083A	P58336A	P58436A
Oyster	P53022A	P53042A	P53062A	P53082A	P58337A	P58437A
Palm Oyster	P53020A	P53040A	P53060A	P53080A	P58338A	P58438A
Pearl Grey	P20869C	P20870C	P21930C	P21974C	P58339A	P58439A
Medium Grey	P27325A	P27326A	P27363A	P27364A	P58340A	P58440A
Traffic Grey	P53036A	P53056A	P53076A	P53096A	P58341A	P58441A
Dark Grey	P27327A	P27328A	P27365A	P27366A	P58342A	P58442A
Nimbus Grey	P53035A	P53055A	P53075A	P53095A	P58343A	P58443A
Duranodic	P57480A	P57495A	P57510A	P57525A	P58346A	P58446A
Deep/Mahogany/Bir.	P20851C	P20852C	P21925C	P20969C	P58347A	P58447A
Russet Brown	P27491A	P27492A	P27493A	P27494A	P58348A	P58448A
Saddle Brown	P35320A	P35321A	P35342A	P35343A	P58349A	P58449A
Sandstone	P27331A	P27332A	P27369A	P27370A	P58350A	P58450A
Tan	P20883C	P20884C	P21926C	P20970C	P58351A	P58451A
Beige	P20885C	P20886C	P21914C	P20958C	P58352A	P58452A
Fawn	P27333A	P27334A	P27371A	P27372A	P58353A	P58453A
Primrose Yellow	P57477A	P57492A	P57507A	P57522A	P58354A	P58454A
Bright Yellow	P20861C	P20862C	P21921C	P20965C	P58355A	P58455A
Sunflower	P27495A	P27496A	P27497A	P27498A	P58356A	P58456A
Chrome Yellow	P57478A	P57493A	P57508A	P57523A	P58357A	P58457A
Imitation Gold	P27337A	P27338A	P27375A	P27376A	P58358A	P58458A
Apricot	P27339A	P27340A	P27377A	P27378A	P58359A	P58459A
Coral	P53029A	P53049A	P53069A	P53089A	P58360A	P58460A
Dark Coral	P53030A	P53050A	P53070A	P53090A	P58361A	P58461A
Light Orange	P27499A	P27500A	P27501A	P27502A	P58362A	P58462A
Bright Orange	P20863C	P20864C	P21923C	P20967C	P58363A	P58463A
Intense Orange	P53026A	P53046A	P53066A	P53086A	P58364A	P58464A
Terra Cotta	P27341A	P27342A	P27379A	P27380A	P58365A	P58465A
Salmon Pink	P35322A	P35323A	P35344A	P35345A	P58366A	P58466A
Mauve	P35324A	P35325A	P35346A	P35347A	P58367A	P58467A
Magenta	P27343A	P27344A	P27381A	P27382A	P58368A	P58468A
Process Magenta	P53034A	P53054A	P53074A	P53094A	P58369A	P58469A
Warm Red	P53027A	P53047A	P53067A	P53087A	P58370A	P58470A
Matte Red	P57481A	P57496A	P57511A	P57526A	P58371A	P58471A
Perfect Match Red	P53025A	P53045A	P53065A	P53085A	P58372A	P58472A

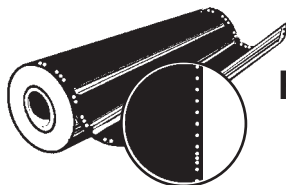

SERIES 220 PREMIUM 3M SCOTCHCAL FILM cont.

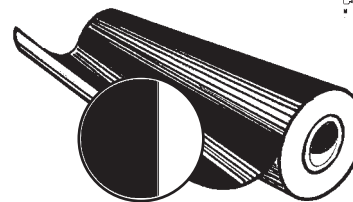

Color	Perforated Rolls				Non-Perforated Rolls	
	15" x 10 yd	15" x 50 yd	30" x 10 yd	30" x 50 yd	30" x 10 yd	30" x 50 yd
Atomic Red	P57468A	P57483A	P57498A	P57513A	P58373A	P58473A
Tomato Red	P20865C	P20866C	P21917C	P20961C	P58374A	P58474A
Geranium	P27503A	P27504A	P27505A	P27506A	P58375A	P58475A
Cardinal Red	P20881C	P20882C	P21920C	P20964C	P58376A	P58476A
Cranberry	P53038A	P53058A	P53078A	P53098A	P58377A	P58477A
Burgundy	P21032C	P21033C	P22304C	P22305C	P58378A	P58478A
Dark Burgundy	P57471A	P57486A	P57501A	P57516A	P58379A	P58479A
Dark Violet	P35326A	P35327A	P35348A	P35349A	P58380A	P58480A
Dark Magenta	P53028A	P53048A	P53068A	P53088A	P58381A	P58481A
Raspberry	P53031A	P53051A	P53071A	P53091A	P58382A	P58482A
Violet	P27345A	P27346A	P27383A	P27384A	P58383A	P58483A
Pale Lavender	P53021A	P53041A	P53061A	P53081A	P58384A	P58484A
Royal Purple	P27347A	P27348A	P27385A	P27386A	P58385A	P58485A
Purple	P27349A	P27350A	P27387A	P27388A	P58386A	P58486A
Royal Blue	P57479A	P57494A	P57509A	P57524A	P58387A	P58487A
Navy	P21036C	P21037C	P22334C	P22335C	P58388A	P58488A
Light Navy	P35328A	P35329A	P35350A	P35351A	P58389A	P58489A
Dark Blue	P57475A	P57490A	P57505A	P57520A	P58390A	P58490A
Shadow Blue	P35330A	P35331A	P35352A	P35353A	P58391A	P58491A
Wedgewood Blue	P35332A	P35333A	P35354A	P35355A	P58392A	P58492A
Sapphire Blue	P20873C	P20874C	P21928C	P20972C	P58393A	P58493A
Vivid Blue	P20875C	P20876C	P21913C	P20957C	P58394A	P58494A
Matte Blue	P57482A	P57497A	P57512A	P57527A	P58395A	P58495A
Intense Blue	P20857C	P20858C	P21922C	P20966C	P58396A	P58496A
Periwinkle	P57473A	P57488A	P57503A	P57518A	P58397A	P58497A
Olympic Blue	P20877C	P20878C	P21929C	P20973C	P58398A	P58498A
Sky Blue	P57474A	P57489A	P57504A	P57519A	P58399A	P58499A
Peacock Blue	P21034C	P21035C	P22332C	P22333C	P58400A	P58500A
Robin Egg Blue	P27351A	P27352A	P27389A	P27390A	P58401A	P58501A
Powder Blue	P53033A	P53053A	P53073A	P53093A	P58402A	P58502A
Aqua	P35334A	P35335A	P35356A	P35357A	P58403A	P58503A
Dark Aqua	P35336A	P35337A	P35358A	P35359A	P58404A	P58504A
Blue Bird	P57472A	P57487A	P57502A	P57517A	P58405A	P58505A
Teal	P27353A	P27354A	P27391A	P27392A	P58406A	P58506A
Celestial Blue	P57470A	P57485A	P57500A	P57515A	P58407A	P58507A
Bermuda Blue	P53032A	P53052A	P53072A	P53092A	P58408A	P58508A
Apple Green	P35338A	P35339A	P35360A	P35361A	P58409A	P58509A
Jade Green	P53037A	P53057A	P53077A	P53097A	P58410A	P58510A
Kelly Green	P20859C	P20860C	P21924C	P20968C	P58411A	P58511A
Bright Green	P35340A	P35341A	P35362A	P35363A	P58412A	P58512A
Cactus Green	P57469A	P57484A	P57499A	P57514A	P58413A	P58513A
Dark Green	P20879C	P20880C	P21927C	P20971C	P58414A	P58514A

Graphics

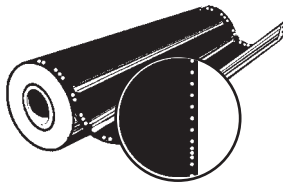

**SERIES 220
PREMIUM 3M SCOTCHCAL FILM cont.**

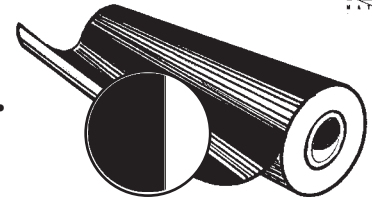

Color	Perforated Rolls				Non-Perforated Rolls	
	15" x 10 yd	15" x 50 yd	30" x 10 yd	30" x 50 yd	30" x 10 yd	30" x 50 yd
Eucalyptus	P57476A	P57491A	P57506A	P57521A	P58415A	P58515A
Forest Green	P27355A	P27356A	P27393A	P27394A	P58416A	P58516A
Bottle Green	P53039A	P53059A	P53079A	P53099A	P58417A	P58517A
Clear Enamel Receptive	P27323A	P27324A	P27361A	P27362A	P58418A	P58518A

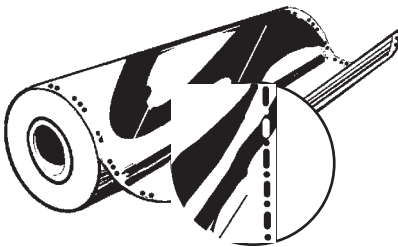

**SERIES 220
METALLIC FILM**

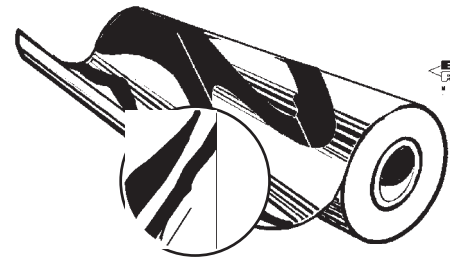

High performance 2 mil cast vinyl with the visual addition of a metallic sparkle. These films are perfect for use on cars, trucks, boats, RV's and signs. Excellent durability with five-to-seven year exterior life. Other widths also available.

Color	Perforated Rolls				Non-Perforated Rolls	
	15" x 10 yd	15" x 50 yd	30" x 10 yd	30" x 50 yd	30" x 10 yd	30" x 50 yd
Silver	P27359A	P27360A	P27397A	P27398A	P58432A	P58532A
Gold	P27357A	P27358A	P27395A	P27396A	P58431A	P58531A
Light Gold	P31813A	P31814A	P31858A	P31859A	P58430A	P58530A
Sage Green	P31843A	P31844A	P31888A	P31889A	P58419A	P58519A
Pine Green	P31840A	P31841A	P31885A	P31886A	P58420A	P58520A
Dark Blue	P31828A	P31829A	P31873A	P31874A	P58421A	P58521A
Bright Blue	P31831A	P31832A	P31876A	P31877A	P58422A	P58522A
Silver Blue	P31834A	P31835A	P31879A	P31880A	P58423A	P58523A
Charcoal	P31801A	P31802A	P31846A	P31847A	P58424A	P58524A
Slate	P31837A	P31838A	P31882A	P31883A	P58425A	P58525A
Burgundy	P31819A	P31820A	P31864A	P31865A	P58426A	P58526A
Light Rose	P31816A	P31817A	P31861A	P31862A	P58427A	P58527A
Dark Brown	P31804A	P31805A	P31849A	P31850A	P58428A	P58528A
Copper	P31810A	P31811A	P31855A	P31856A	P58429A	P58529A

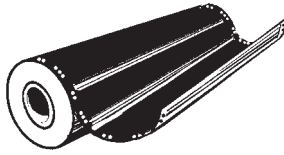

**SERIES 230
TRANSLUCENT VINYL FILM**

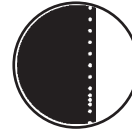

High performance 2 mil cast vinyl designed for use on internally illuminated signs, awnings and window graphics. Features uniform color with a surface finish to eliminate glare. Five year exterior life.

Color	Perforated Rolls			
	15" x 10 yd	15" x 50 yd	30" x 10 yd	30" x 50 yd
White	P20921C	P20922C	P21948C	P20992C
Ivory	P21028C	P21029C	P22299C	P22300C
Light Beige	P37721A	P37707A	P37693A	P37679A
Silver	P43249A	P43250A	P43257A	P43258A
Silver Gray	P37714A	P37700A	P37686A	P37672A
Shadow Gray	P37719A	P37705A	P37691A	P37677A
State Gray	P37716A	P37702A	P37688A	P37674A
Black	P37708A	P37694A	P37680A	P37666A
Rust Brown	P20911C	P20912C	P21943C	P20987C
Dark Brown	P20919C	P20920C	P21947C	P20991C
Duranodic	P20913C	P20914C	P21944C	P20988C
Burgundy	P21026C	P21027C	P22297C	P22298C
Raspberry	P37710A	P37696A	P37682A	P37668A
Mulberry	P51447A	P51461A	P51475A	P51489A
Vivid Rose	P37713A	P37699A	P37685A	P37671A
Pink Lavender	P51444A	P51458A	P51472A	P51486A
Cardinal Red	P30810A	P30811A	P30822A	P30823A
Dark Red	P20917C	P20918C	P21946C	P20990C
Scarlet Red	P51441A	P51455A	P51469A	P51483A
Red	P20909C	P20910C	P21942C	P20986C
Light Tomato Red	P30808A	P30809A	P30820A	P30821A
Poppy Red	P37711A	P37697A	P37683A	P37669A
Orange	P20907C	P20908C	P21941C	P20985C
Tangerine	P37717A	P37703A	P37689A	P37675A
Kumquat	P37718A	P36704A	P37690A	P37676A
Gold Nugget ⁽¹⁾	P51451A	P51465A	P51479A	P51493A

Color	Perforated Rolls			
	15" x 10 yd	15" x 50 yd	30" x 10 yd	30" x 50 yd
Metallic Gold ⁽¹⁾	P37712A	P37698A	P37684A	P37670A
Sunflower	P30806A	P30807A	P30818A	P30819A
Mango	P51448A	P51462A	P51476A	P51490A
Yellow	P20905C	P20906C	P21940C	P20984C
Lemon Yellow	P51445A	P51459A	P51473A	P51487A
Emerald Green	P51449A	P51463A	P51477A	P51491A
Holly Green	P30814A	P30815A	P30826A	P30827A
Green	P20903C	P20904C	P21939C	P20983C
Bright Jade Green	P51446A	P51460A	P51474A	P51488A
Vivid Green	P37715A	P37701A	P37687A	P37673A
Kelly Green	P51452A	P51466A	P51480A	P51494A
Apple Green	P51443A	P51457A	P51471A	P51485A
Teal	P43253A	P43254A	P43261A	P43262A
Turquoise	P43251A	P43252A	P43259A	P43260A
Dark Blue	P21030C	P21031C	P22301C	P22302C
Royal Blue	P20915C	P20916C	P21945C	P20989C
Cobalt Blue	P51454A	P51468A	P51482A	P51496A
Delft Blue	P51442A	P51456A	P51470A	P51484A
Blue	P31344A	P31345A	P31346A	P31347A
Intense Blue	P37709A	P37695A	P37681A	P37667A
Process Blue	P49908A	P49909A	P49910A	P49911A
Deep Sky Blue	P51453A	P51467A	P51481A	P51495A
Olympic Blue	P30812A	P30813A	P30824A	P30825A
Plum Purple	P51450A	P51464A	P51478A	P51492A

NOTE: ⁽¹⁾ 3 year exterior life.

Graphics

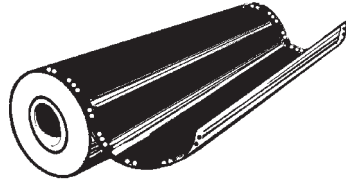

SERIES 210 3M SCOTCHCAL FILM

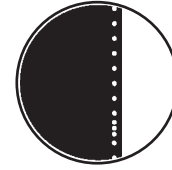

FLUORESCENT FILM



Vibrant films providing excellent visibility under normal or low light conditions. Perfect for POP, window graphics and displays. One year exterior life.

Color	Perforated Rolls 15" x 10 yd
Yellow Orange	P48303A
Lemon Yellow	P48304A
Lime Green	P48305A
Blue	P48306A
Pink	P48307A
Red Orange	P48534A

DUSTED/FROSTED CRYSTAL SPECIALTY FILM

Dusted Crystal provides the appearance of etched glass and Frosted Crystal provides the appearance of sandblasted glass. Perfect for all windows, glass, mirror and clear plastic applications. Three-year exterior life.

Description	Perforated Rolls			
	15" x 10 yd	15" x 50 yd	30" x 10 yd	30" x 50 yd
Dusted Crystal	P32442A	P32443A	P32444A	P32445A
Frosted Crystal	P35717A	P35718A	P35715A	P35716A



SERIES 280 & 280i 3M SCOTCHCAL REFLECTIVE SHEETING



Series 280 reflective sheeting is designed for markings requiring high visibility, both day and night. Material has good flexibility and provides excellent conformance to flat or moderately curved surfaces. Seven-year exterior life on all colors, five-year exterior life on black.

Series 280i white reflective sheeting is designed to provide optimal print results on the Gerber Edge. Seven-year exterior life.

Color	Perforated Rolls			
	15" x 10 yd	15" x 50 yd	30" x 10 yd	30" x 50 yd
Gold	P21020C	P21021C	P21962C	P21008C
White ⁽¹⁾	P20887C	P20888C	P21931C	P20975C
Black	P20899C	P20900C	P21933C	P20977C
Ruby Red	P37319A	P37320A	P37321A	P37322A
Red	P28494A	P28495A	P28498A	P28499A
Orange	P20895C	P20896C	P21936C	P20980C
Lemon Yellow	P20893C	P20894C	P21934C	P20978C
Yellow	P28496A	P28497A	P28500A	P28501A
Green	P20891C	P20892C	P21937C	P20981C
Light Blue	P39822A	P39823A	P39820A	P39821A
Blue	P20889C	P20892C	P21932C	P20976C
White Series 280i ⁽¹⁾	P60923A	P60924A	-	-

NOTE: ⁽¹⁾ Gerber recommends series 280i white reflective sheeting for Edge applications.

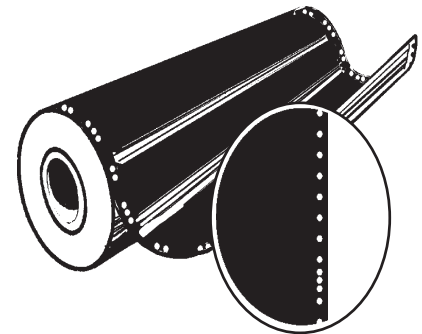



QUANTUM 2000 FILM

Quantum 2000 is a custom formulated, 3.6 mil polymeric calendered vinyl. An economical, yet extremely versatile product with a five year exterior life. Other widths also available.

Color	Perforated Rolls	
	15" x 50 yd	30" x 50 yd
Matte White	P69021A	P69147A
White	P69016A	P69142A
Matte Black	P69023A	P69149A
Black	P69017A	P69143A
Brown	P69035A	P69161A
Beige	P69032A	P69158A
Yellow	P69020A	P69146A
Orange	P69030A	P69156A
Tomato Red	P69024A	P69150A
Red	P69018A	P69144A
Burgundy	P69026A	P69152A
Fuchsia	P69036A	P69162A
Purple	P69028A	P69154A
Navy	P69034A	P69160A
Sapphire Blue	P69019A	P69145A
Blue	P69022A	P69148A
Olympic Blue	P69033A	P69159A
Teal	P69029A	P69155A
Green	P69508A	P69511A
Dark Green	P69025A	P69151A
Gold	P69027A	P69153A
Silver	P69031A	P69157A

QUANTUM 4000 FILM

Quantum 4000 film is a state-of-the-art, 3.6 mil polymeric calendered vinyl film with superior gloss and high performance qualities designed to withstand severe weather and handling conditions. Features a clear adhesive and is therefore suitable for use as a cut vinyl in window or transparent substrate applications. An economical, yet extremely versatile product with a six year exterior life. Other widths also available.

Color	Perforated Rolls	
	15" x 50 yd	30" x 50 yd
Black	P68576A	P68816A
White	P68575A	P68815A
Beige	P68592A	P68832A
Bright Green	P68594A	P68834A
Bright Yellow	P68583A	P68823A
Burgundy	P68584A	P68824A
Cardinal Red	P68577A	P68817A
Dark Gray	P68595A	P68835A
Dark Green	P68585A	P68825A
Forest Green	P68588A	P68828A
Gold	P68580A	P68820A
Imitation Gold	P68598A	P68838A
Intense Red	P68600A	P68840A
Light Blue	P68599A	P68839A
Lime Green	P68604A	P68844A
Magenta	P68602A	P68842A
Mahogany Brown	P68597A	P68837A
Medium Gray	P68589A	P68829A
Navy	P68587A	P68827A
Olympic Blue	P68591A	P68831A
Orange	P68596A	P68836A
Primrose Yellow	P68601A	P68841A
Royal Purple	P68593A	P68833A
Sapphire Blue	P68578A	P68818A
Silver	P68581A	P68821A
Sunflower	P68586A	P68826A
Teal	P68590A	P68830A
Tomato Red	P68579A	P68819A
Vivid Blue	P68582A	P68822A
Warm Red	P68603A	P68843A

Graphics

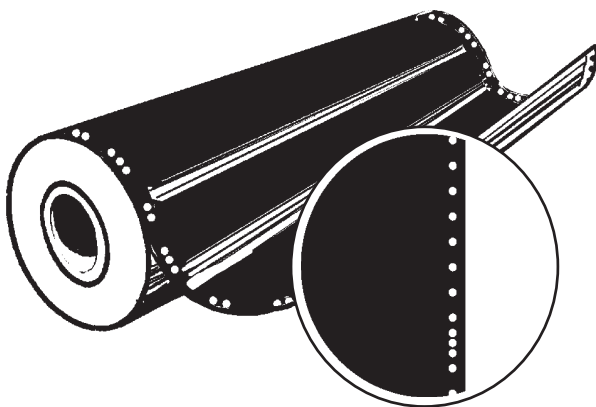



METALLIZED POLYESTER FILM



Polyester, 1 or 2 mil film, for use in the Gerber Edge for the production of display graphics, labels, decals and identification nameplates. Both products feature a brushed, metallized finish and are not recommended for exterior use.

Polyester, 2 or 3 mil film with mirror look for interior and limited exterior use. One to two-year life on Silver and Brushed Aluminum. Gold polyesters are not recommended for exterior use.

Color	Perforated Rolls			
	1 MIL		2 MIL	
	15" x 10 yd	15" x 50 yd	15" x 10 yd	15" x 50 yd
Brushed Gold	P61297A	P61296A	P61288A	P61289A
Brushed Silver	P61300A	P61299A	P61285A	P61286A

Color	Perforated Rolls	
	15" x 10 yd	15" x 50 yd
Shiny Gold w/Silver Backing	P21014C	P21015C
Shiny Gold w/Gold Backing	P26697A	P26696A
Brushed Aluminum Shiny Silver	P21016C P21018C	P21017C P21019C

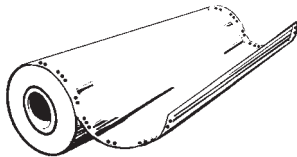

SPECIALTY PRINTING MATERIALS

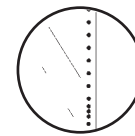

STATIC CLING FILM



Designed to adhere to glass without adhesive, these specialty vinyls are ideally suited to work with the Gerber Edge. Intended for interior applications. Can also be decorated with vinyl graphics.

Color	Perforated Rolls	
	15" x 10 yd	15" x 50 yd
Clear	P50823A	P50824A
White	P53201A	P53202A

SCREENPRINTING FILM



Crystal clear, 7 mil top coated polyester film. For Gerber Edge use in the production of screening film positives. Designed for use with Spot black GerberColor cartridges.

Color	Perforated Rolls	
	15" x 10 yd	15" x 50 yd
Clear	P54964A	P54965A

ADHESIVE BACKED CLEAR FILM

Cast, 2 mil clear vinyl with clear adhesive that can be reverse printed for sub-surface or second surface applications. Excellent durability with five-year exterior life.

Color	Perforated Rolls	
	15" x 10 yd	15" x 50 yd
Clear	P27323A	P27324A

SMOOTH LABEL STOCK



Polyester, 1 or 2 mil material for use in the Gerber Edge for the production of labels, decals and identification nameplates. Matte Silver only available in 2 mil thickness.

Color	Perforated Rolls			
	1 MIL		2 MIL	
	15" x 10 yd	15" x 50 yd	15" x 10 yd	15" x 50 yd
Clear	P59875A	P59876A	P59878A	P59879A
White	P59881A	P59882A	P59884A	P59885A
Matte Silver	-	-	P60557A	P60558A

MAGNETIC SHEETING



Flexible magnetic material with a white matte surface. For optimal printing on the Gerber Edge. Output contour cut on any Graphix Advantage compatible 15" plotter. GerberMag 15 mil is used in the production of custom ad specialty magnets. Vehicle strength AutoMag 24 mil is used for production of removable vehicle graphics. Also available in 100' rolls.

Description	Perforated Rolls	
	15 MIL 15" x 25 ft	24 MIL 15" x 25 ft
GerberMag	P55112A	-
AutoMag	-	P59763A

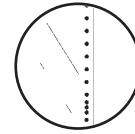
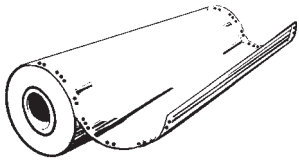

GERBER EDGE READY SPECIALTY MATERIALS

Gerber offers a wide range of materials, identified by the Edge Ready symbol, designed and warranted specifically for use in the Gerber Edge and Edge II. The following materials are part of the growing Edge Ready specialty printing materials group. Additional Edge Ready materials are always being developed. Please call for up-to-date Edge Ready materials information.

EDGE POSITIVE



EdgePositive is a crystal clear 7 mil polyester film designed for use with the Gerber Edge and GerberColor Spot black foil in the production of screen print film positives.

Perforated Rolls	
15" x 10 yd	15" x 50 yd
P54964A	P54965A

3M FLOORMINDERS



This dynamic Edge Ready material allows Gerber Edge users to realize the retail advertising potential of floor space and counter tops. Available only to authorized fabricators, the 3M FloorMinders package includes both Controltac 160 film and Scotchcal overlaminates 3645 film. Please call for necessary forms to become a FloorMinder authorized fabricator.

15" x 10 yd Roll	15" x 50 yd Roll
P66992A	P66991A

GERBER GLOW LUMINOUS FILM



1.3mil, durable glow-in-the-dark vinyl custom formulated for use with the Gerber Edge in the production of graphics that are visible in total darkness. Luminous Film glows for up to 6 hours and takes only 3 minutes of light exposure to recharge. Ideal for emergency and exit signage as well as general signs that demand maximum visibility. Available in luminous green only.

15" x 10 yd Roll	15" x 50 yd Roll
P68495A	P68496A

GERBER GUARD OVERLAMINATE



Designed for additional protection from petroleum based or other chemicals as well as increased abrasion protection to Edge graphics. Glossy, lustrous finish. UV version is a custom formulated Tedlar film that offers resistant from UV rays and environmental pollution. Overlaminates not intended for printing.

	15" x 10 yd Roll	15" x 50 yd Roll
Gerber Gaurd	P61385A	P61386A
Gerber UV Gaurd	P65978A	P65979A

GERBERVISION WINDOW FILM



GerberVision clear window film is designed for transit and retail window applications. Its perforation allows one to see through the clear substrate when viewed from reverse.

Perforated Rolls	
15" x 10 yd	15" x 50 yd
P63021A	P63022A

HEAT TRANSFER PAPER



Use with GerberColor L.T. (GCLT) Series Foils to produce wash-fast and durable textile transfers.

Perforated Rolls	
15" x 10 yd	15" x 50 yd
P60345A	P60346A

HOLOGRAPHIX PRISMATIC VINYL



Available in four different patterns that range from mirror finish to prismatic rays. These vinyls create a spectrum of colors that add dynamic effects to graphics. Can be over printed with GCT transparent foils for spectacular effects. Also available in custom widths.

Pattern	Perforated Rolls	
	15" x 10 yd	15" x 50 yd
Silver Sheen	P63221A	P63222A
Mosaic	P63224A	P63225A
Kaleidoscope	P63227A	P63228A
Crystal Blizzard	P63230A	P63231A

GERBER IMAGECAL P FILM



Clear calendared vinyl film that offers a permanent adhesive system that is outdoor durable for up to two years from the time of application. Also extremely easy to handle and apply, Gerber ImageCal P is perfect for window displays, exhibit and trade show graphics and P.O.P. displays.

15" x 10 yd Roll	15" x 50 yd Roll
P65583A	P65584A

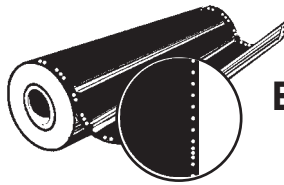

GERBER EDGE READY SPECIALTY MATERIAL cont.

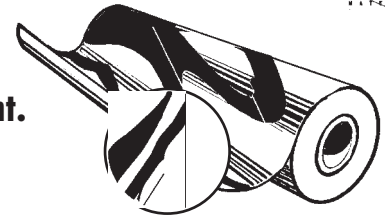

GERBER IMAGECAL R FILM



Clear calendared vinyl film that offers a removable adhesive system for up to six months from the time of application. Easy to handle and apply, Gerber ImageCal R is ideal for labels, decals and P.O.P. displays.

15" x 10 yd Roll	15" x 50 yd Roll
P65587A	P65588A

GERBER IMAGECAST ECLIPSE



A versatile 2mil, semi-transparent tinted vinyl. Ideal for window graphics, vehicle graphics, decals and sign of all kinds where realistic shadowing and high visual impact are desired. Also available in 30" width rolls.

15" x 10 yd Roll	15" x 50 yd Roll
P68487A	P68488A

IMAGECAST FILM



A 2 mil clear pressure sensitive vinyl film for use in the production of window displays, exhibit graphics and identification labeling.

15" x 10 yd Roll	15" x 50 yd Roll
P65579A	P65580A

INSTACHANGE REMOVABLE VINYL FILM



White 4 mil material that provides Edge users with a material solution for graphics, decals and labels that require a strong bond, yet must be easily removed and changed with a new marking. Simply remove and replace for up to two years with no adhesive residue.

15" x 10 yd Roll	15" x 50 yd Roll
P63030A	P63031A

3M INSTACHANGE VINYL



A white removable vinyl which has a strong bond yet is easily removed and replaced for up to 2 years with out adhesive residue. For short term or repeated replacement application

Perforated Rolls	
15" x 10 yd	15" x 50 yd
P63030A	P63031A

3M PANAFLEX 645



A rugged, durable white face material with a matte finish designed for translucent and opaque applications including internally illuminated signs, exhibits and banners. To produce direct print translucent graphics for backlit applications, a double-hit method is recommended with either transparent or process series foils.

Perforated Rolls	
15" x 10 yd	15" x 50 yd
P63532A	P63533A

PERMAGRIP



PermaGrip is a durable cast white vinyl featuring an extremely aggressive, pigmented adhesive. Ideal for all surfaces. Good on low surface energy substrates and moderately rough surfaces where exceptional "vandal resistant" characteristics are needed.

Perforated Rolls	
15" x 10 yd	15" x 50 yd
AP75517-10Y	AP75517-50Y

PLASTIGRAPHIX LEXEDGE CLEAR



Polished version of LexEdge II with a removable protective mask on the print side. Ideal for use in architectural signage, point-of-purchase displays, exhibit graphics and membrane switches.

Perforated Rolls	
15" x 10 yd	15" x 50 yd
P67002A	P67003A

PLASTIGRAPHIX LEXEDGE II



A clear velvet/polished, 10 mil semi-rigid Lexan® film for the production of exhibits, displays, ad speciality items and other types of sub-surface graphics. The polished velvet side of this material will generally be the viewing side. Since the print surface is the opposite side and LexEdge II will most often be used in second surface applications, reverse print procedures will need to be followed.

Perforated Rolls	
15" x 10 yd	15" x 50 yd
P63562A	P63563A

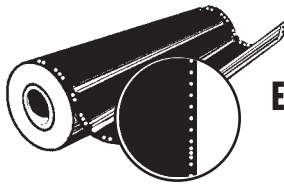

GERBER

EDGE READY SPECIALTY MATERIAL cont.

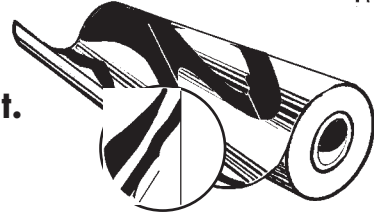

PLASTIGRAPHIX OUTDOOR LEXEDGE



10 mil matte/polished clear semi-rigid Lexan® based polycarbonate with a matte/polished clear finish. Offers the benefit of printing directly onto the final substrate in second surface applications. Resists tearing, abrasion and the yellowing effects from UV exposure. Features a removable protective mask on both sides for optimal printing.

Perforated Rolls	
15" x 10 yd	15" x 50 yd
P72790A	P72791A

GERBER PLASTIGRAPHIX PVC-10HG



Custom-coated 10mil PVC material with a bright white, high gloss surface developed for use with the Edge in the production of all types of semi-rigid graphics including signs, menu boards, point-of-sale displays, permit and identification tags, door hangers and exhibit graphics. PVC-10 may be score-cut using any Gerber-compatible 15" plotter.

15" x 10 yd Roll	15" x 50 yd Roll
P75074A	P75075A

SECURITY LABEL STOCK



4 mil chrome silver label stock used to produce tamper-evident identification markings. If label is removed, the word "VOID" remains on the applied surface and on the label.

Perforated Rolls	
15" x 10 yd	15" x 50 yd
P63033A	P63034A

SERIES 210 DELUXE SILVER



Deluxe silver is a mirror finish vinyl film that can be used in standard cut vinyl graphics and Gerber Edge systems. Expect 3-5 years outdoor durability.

Perforated Rolls		
15" x 10 yd	15" x 50 yd	30" x 50 yd
P51895A	P57757A	P51897A

STARDUST



2 mil cast vinyl featuring an ultrametallic flake. Pigmented adhesive system, outdoor durability and visual appeal is ideal for vehicle, marine and graphic applications of all kinds. Use with GerberColor foils such as the transparent series GCLT to create other Stardust colors.

Color	Perforated Rolls	
	15" x 10 yd	15" x 50 yd
Metallic Stardust Gold	P74779A	P74780A
Metallic Stardust Silver	P74782A	P74783A

Graphics

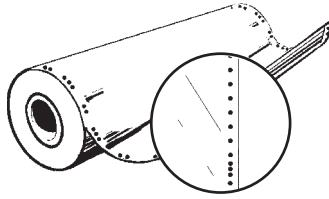

GERBER SPECIALTY MATERIAL

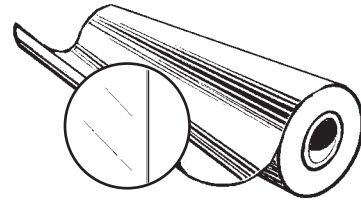

GERBERMASK I

GerberMask I is a 4 mil, white vinyl film coated with a low tack removable adhesive. Designed to be used as a stencil masking film for application to a variety of smooth, flat substrates. The low-tack adhesive allows for easy removal with no adhesive transfer and easy removal from high energy surfaces. Suitable for use on glass, acrylic, polycarbonate, flexible vinyl or stainless steel.

Description	Perforated Rolls				Non-Perforated Rolls			
	15" x 10 yd	15" x 50 yd	30" x 10 yd	30" x 50 yd	20" x 10 yd	20" x 50 yd	45" x 10 yd	45" x 50 yd
GerberMask I Standard Tack Adhesive Red Logo Printed on Liner	P28484A	P28485A	P28486A	P28487A	P59448A	P59449A	P59454A	P59455A

GERBERMASK II

GerberMask II is a durable, conformable 4 mil white vinyl film coated with an aggressive acrylic removable adhesive. Designed to hold during light sandblasting, acid etching or paint applications. Easily removable with no adhesive transfer. Suitable for use on glass, Acrylic, polycarbonate, flexible vinyl, stainless steel and unfinished or finished wood surfaces. Not for application on flexible vinyl film. GerberMask II will adhere strongly to smooth, high energy surfaces such as Acrylic and polycarbonate. GerberMask II requires some effort to remove.

Description	Perforated Rolls		Non-Perforated Rolls		
	15" x 50 yd	30" x 50 yd	20" x 50 yd	30" x 50 yd	45" x 50 yd
GerberMask II High Tack Adhesive Blue Logo Printed on Liner	P35872A	P37055A	P59457A	P59459A	P59461A

SCREENPRINTING & GRAPHIC ARTS FILMS

Carefully selected materials designed for screenprinting. Developed for use on Gerber systems.

Description	Perforated Rolls			
	15" x 25 ft	15" x 50 yd	30" x 25 ft	30" x 50 yd
Ulano Rubylith G3GR	P21038C	P21039C	P26930A	P26931A
Ulano Rubylith RM3	P20946C	P20947C	P21958C	P21002C
Ulano Amberlith A3A	P20948C	P20949C	P21959C	P21003C
Ulano Cut Green	P20950C	P20951C	P21960C	P21004C
Ulano S3S-StaSharp	P20952C	P20953C	P21961C	P21005C

SANDBLASTING MASK

Single or double liner, rubber masking stencil for sandblasting on stone, glass and hard or soft

Description	Perforated Rolls	
	15" x 10 yd	30" x 10 yd
3M Scotch Brand #521 One-liner for Stone and Wood	P47527A	P47529A
3M Scotch Brand #522 Two-liner for Stone and Wood	P47528A	P47530A

DRAWING & POUNCING PAPER

Plain white, 20# paper for producing scaled or full-size line drawings and pounce patterns.

Description	Perforated Rolls			
	15" x 100 ft	15" x 500 yd	30" x 100 ft	30" x 300 yd
Plain White, 20#	-	P20944C	-	P21965C
Drafting Vellum	P20945C	-	P22303C	-

SANDBLASTING TRANSFER TAPE

Description	Rolls 6" x 72 yd
Sandblast Transfer Tape	P26522A

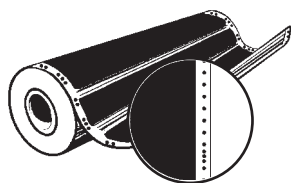
ARLON

SERIES 2200 & 2100 HIGH PERFORMANCE FILM

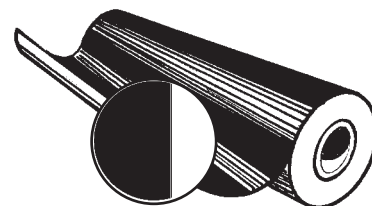

High performance 2 mil cast vinyl. Increased productivity provided by a unique liner design for easier cutting, faster consistent weeding and effortless character transfer. Excellent durability for seven years. Vinyl has been removed from the perforated margin for trouble free feeding. Other widths also available.

Color	Perforated Rolls				Non-Perforated Rolls		
	15" x 10 yd	15" x 50 yd	30" x 10 yd	30" x 50 yd	20" x 50 yd	24" x 50 yd	48" x 50 yd
Clear	2200-1503-00	2200-1515-00	2200-3003-00	2200-3015-00	2100-2015-00	2100-2415-00	2100-4815-00
Red	2200-1503-01	2200-1515-01	2200-3003-01	2200-3015-01	2100-2015-01	2100-2415-01	2100-4815-01
White	2200-1503-02	2200-1515-02	2200-3003-02	2200-3015-02	2100-2015-02	2100-2415-02	2100-4815-02
Black	2200-1503-03	2200-1515-03	2200-3003-03	2200-3015-03	2100-2015-03	2100-2415-03	2100-4815-03
Gold Metallic	2200-1503-04	2200-1515-04	2200-3003-04	2200-3015-04	2100-2015-04	2100-2415-04	2100-4815-04
Blue	2200-1503-05	2200-1515-05	2200-3003-05	2200-3015-05	2100-2015-05	2100-2415-05	2100-4815-05
Yellow	2200-1503-06	2200-1515-06	2200-3003-06	2200-3015-06	2100-2015-06	2100-2415-06	2100-4815-06
Silver Metallic	2200-1503-07	2200-1515-07	2200-3003-07	2200-3015-07	2100-2015-07	2100-2415-07	2100-4815-07
Brown	2200-1503-08	2200-1515-08	2200-3003-08	2200-3015-08	2100-2015-08	2100-2415-08	2100-4815-08
Dark Blue	2200-1503-11	2200-1515-11	2200-3003-11	2200-3015-11	2100-2015-11	2100-2415-11	2100-4815-11
Burgundy	2200-1503-12	2200-1515-12	2200-3003-12	2200-3015-12	2100-2015-12	2100-2415-12	2100-4815-12
Tomato Red	2200-1503-14	2200-1515-14	2200-3003-14	2200-3015-14	2100-2015-14	2100-2415-14	2100-4815-14
Sapphire Blue	2200-1503-17	2200-1515-17	2200-3003-17	2200-3015-17	2100-2015-17	2100-2415-17	2100-4815-17
Olympic Blue	2200-1503-18	2200-1515-18	2200-3003-18	2200-3015-18	2100-2015-18	2100-2415-18	2100-4815-18
Smoke Metallic	2200-1503-21	2200-1515-21	2200-3003-21	2200-3015-21	2100-2015-21	2100-2415-21	2100-4815-21
Charcoal Metallic	2200-1503-23	2200-1515-23	2200-3003-23	2200-3015-23	2100-2015-23	2100-2415-23	2100-4815-23
Dark Green	2200-1503-24	2200-1515-24	2200-3003-24	2200-3015-24	2100-2015-24	2100-2415-24	2100-4815-24
Oyster	2200-1503-26	2200-1515-26	2200-3003-26	2200-3015-26	2100-2015-26	2100-2415-26	2100-4815-26
Fawn	2200-1503-27	2200-1515-27	2200-3003-27	2200-3015-27	2100-2015-27	2100-2415-27	2100-4815-27
Dove Gray	2200-1503-28	2200-1515-28	2200-3003-28	2200-3015-28	2100-2015-28	2100-2415-28	2100-4815-28
Dark Blue Metallic	2200-1503-30	2200-1515-30	2200-3003-30	2200-3015-30	2100-2015-30	2100-2415-30	2100-4815-30
Ocean Blue	2200-1503-31	2200-1515-31	2200-3003-31	2200-3015-31	2100-2015-31	2100-2415-31	2100-4815-31
Azure Blue	2200-1503-32	2200-1515-32	2200-3003-32	2200-3015-32	2100-2015-32	2100-2415-32	2100-4815-32
Brown Metallic	2200-1503-35	2200-1515-35	2200-3003-35	2200-3015-35	2100-2015-35	2100-2415-35	2100-4815-35
Med. Blue Metallic	2200-1503-37	2200-1515-37	2200-3003-37	2200-3015-37	2100-2015-37	2100-2415-37	2100-4815-37
Burgundy Metallic	2200-1503-39	2200-1515-39	2200-3003-39	2200-3015-39	2100-2015-39	2100-2415-39	2100-4815-39
Matte Black	2200-1503-40	2200-1515-40	2200-3003-40	2200-3015-40	2100-2015-40	2100-2415-40	2100-4815-40
Cardinal Red	2200-1503-42	2200-1515-42	2200-3003-42	2200-3015-42	2100-2015-42	2100-2415-42	2100-4815-42
Camel Beige	2200-1503-48	2200-1515-48	2200-3003-48	2200-3015-48	2100-2015-48	2100-2415-48	2100-4815-48
Matte White	2200-1503-49	2200-1515-49	2200-3003-49	2200-3015-49	2100-2015-49	2100-2415-49	2100-4815-49
Medium Gray	2200-1503-50	2200-1515-50	2200-3003-50	2200-3015-50	2100-2015-50	2100-2415-50	2100-4815-50
Aruba Blue	2200-1503-51	2200-1515-51	2200-3003-51	2200-3015-51	2100-2015-51	2100-2415-51	2100-4815-51
Dark Gray	2200-1503-52	2200-1515-52	2200-3003-52	2200-3015-52	2100-2015-52	2100-2415-52	2100-4815-52
Dark Bahama Blue	2200-1503-53	2200-1515-53	2200-3003-53	2200-3015-53	2100-2015-53	2100-2415-53	2100-4815-53
Hot Pink	2200-1503-56	2200-1515-56	2200-3003-56	2200-3015-56	2100-2015-56	2100-2415-56	2100-4815-56
Dark Magenta	2200-1503-58	2200-1515-58	2200-3003-58	2200-3015-58	2100-2015-58	2100-2415-58	2100-4815-58
Imitation Gold	2200-1503-59	2200-1515-59	2200-3003-59	2200-3015-59	2100-2015-59	2100-2415-59	2100-4815-59
Lemon Yellow	2200-1503105	2200-1515105	2200-3003105	2200-3015105	2100-2015105	2100-2415105	2100-4815105
Perfect Match Red	2200-1503220	2200-1515220	2200-3003220	2200-3015220	2100-2015220	2100-2415220	2100-4815220
Geranium	2200-1503221	2200-1515221	2200-3003221	2200-3015221	2100-2015221	2100-2415221	2100-4815221
Peacock Red	2200-1503223	2200-1515223	2200-3003223	2200-3015223	2100-2015223	2100-2415223	2100-4815223

Graphics

INTERSTATE ELECTRIC CO., INC.

2240 Yates Ave., Commerce, CA 90040 • 5435 Procyon, #100, Las Vegas, NV 89118 • 6860 Goodyear Rd., Benicia, CA 94510

ARLON

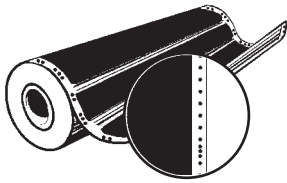

**SERIES 2200 & 2100
HIGH PERFORMANCE FILM cont.**

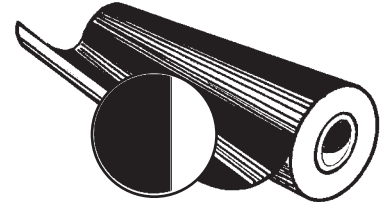

Color	Perforated Rolls				Non-Perforated Rolls		
	15" x 10 yd	15" x 50 yd	30" x 10 yd	30" x 50 yd	20" x 50 yd	24" x 50 yd	48" x 50 yd
Bright Cardinal Red	2200-1503-60	2200-1515-60	2200-3003-60	2200-3015-60	2100-2015-60	2100-2415-60	2100-4815-60
Kelly Green	2200-1503-61	2200-1515-61	2200-3003-61	2200-3015-61	2100-2015-61	2100-2415-61	2100-4815-61
Purple	2200-1503-62	2200-1515-62	2200-3003-62	2200-3015-62	2100-2015-62	2100-2415-62	2100-4815-62
Violet	2200-1503-63	2200-1515-63	2200-3003-63	2200-3015-63	2100-2015-63	2100-2415-63	2100-4815-63
Midnight Blue	2200-1503-65	2200-1515-65	2200-3003-65	2200-3015-65	2100-2015-65	2100-2415-65	2100-4815-65
Med. Blue	2200-1503-66	2200-1515-66	2200-3003-66	2200-3015-66	2100-2015-66	2100-2415-66	2100-4815-66
Primrose Yellow	2200-1503-67	2200-1515-67	2200-3003-67	2200-3015-67	2100-2015-67	2100-2415-67	2100-4815-67
Beige	2200-1503-68	2200-1515-68	2200-3003-68	2200-3015-68	2100-2015-68	2100-2415-68	2100-4815-68
Apple Green	2200-1503-69	2200-1515-69	2200-3003-69	2200-3015-69	2100-2015-69	2100-2415-69	2100-4815-69
Palm Oyster Gray	2200-1503-70	2200-1515-70	2200-3003-70	2200-3015-70	2100-2015-70	2100-2415-70	2100-4815-70
Teal	2200-1503-71	2200-1515-71	2200-3003-71	2200-3015-71	2100-2015-71	2100-2415-71	2100-4815-71
Poppy	2200-1503-73	2200-1515-73	2200-3003-73	2200-3015-73	2100-2015-73	2100-2415-73	2100-4815-73
Royal Purple	2200-1503-74	2200-1515-74	2200-3003-74	2200-3015-74	2100-2015-74	2100-2415-74	2100-4815-74
Lavender	2200-1503-75	2200-1515-75	2200-3003-75	2200-3015-75	2100-2015-75	2100-2415-75	2100-4815-75
Magenta	2200-1503-76	2200-1515-76	2200-3003-76	2200-3015-76	2100-2015-76	2100-2415-76	2100-4815-76
Coral	2200-1503-78	2200-1515-78	2200-3003-78	2200-3015-78	2100-2015-78	2100-2415-78	2100-4815-78
Kiwi	2200-1503-79	2200-1515-79	2200-3003-79	2200-3015-79	2100-2015-79	2100-2415-79	2100-4815-79
Graphite	2200-1503-80	2200-1515-80	2200-3003-80	2200-3015-80	2100-2015-80	2100-2415-80	2100-4815-80
Titanium	2200-1503-81	2200-1515-81	2200-3003-81	2200-3015-81	2100-2015-81	2100-2415-81	2100-4815-81
Raspberry	2200-1503-82	2200-1515-82	2200-3003-82	2200-3015-82	2100-2015-82	2100-2415-82	2100-4815-82
Bright Orange	2200-1503-83	2200-1515-83	2200-3003-83	2200-3015-83	2100-2015-83	2100-2415-83	2100-4815-83
Eggshell	2200-1503-84	2200-1515-84	2200-3003-84	2200-3015-84	2100-2015-84	2100-2415-84	2100-4815-84
Cocoa	2200-1503-85	2200-1515-85	2200-3003-85	2200-3015-85	2100-2015-85	2100-2415-85	2100-4815-85
Forest Green	2200-1503-86	2200-1515-86	2200-3003-86	2200-3015-86	2100-2015-86	2100-2415-86	2100-4815-86
Aqua Green	2200-1503-87	2200-1515-87	2200-3003-87	2200-3015-87	2100-2015-87	2100-2415-87	2100-4815-87
Mint Green	2200-1503-88	2200-1515-88	2200-3003-88	2200-3015-88	2100-2015-88	2100-2415-88	2100-4815-88
Aqua Blue	2200-1503-89	2200-1515-89	2200-3003-89	2200-3015-89	2100-2015-89	2100-2415-89	2100-4815-89
Wedgewood Blue	2200-1503-92	2200-1515-92	2200-3003-92	2200-3015-92	2100-2015-92	2100-2415-92	2100-4815-92
Light Navy	2200-1503-93	2200-1515-93	2200-3003-93	2200-3015-93	2100-2015-93	2100-2415-93	2100-4815-93
Sandust Clay	2200-1503-94	2200-1515-94	2200-3003-94	2200-3015-94	2100-2015-94	2100-2415-94	2100-4815-94
Tangerine	2200-1503-96	2200-1515-96	2200-3003-96	2200-3015-96	2100-2015-96	2100-2415-96	2100-4815-96
Light Orange	2200-1503-97	2200-1515-97	2200-3003-97	2200-3015-97	2100-2015-97	2100-2415-97	2100-4815-97
Slate Green	2200-1503-98	2200-1515-98	2200-3003-98	2200-3015-98	2100-2015-98	2100-2415-98	2100-4815-98
Bright Purple	2200-1503-99	2200-1515-99	2200-3003-99	2200-3015-99	2100-2015-99	2100-2415-99	2100-4815-99
Medium Green	2200-1503106	2200-1515106	2200-3003106	2200-3015106	2100-2015106	2100-2415106	2100-4815106
Pearl	2200-1503120	2200-1515120	2200-3003120	2200-3015120	2100-2015120	2100-2415120	2100-4815120
Bottle Green	2200-1503230	2200-1515230	2200-3003230	2200-3015230	2100-2015230	2100-2415230	2100-4815230
Intense Blue	2200-1503250	2200-1515250	2200-3003250	2200-3015250	2100-2015250	2100-2415250	2100-4815250
Terra Cotta	2200-1503280	2200-1515280	2200-3003280	2200-3015280	2100-2015280	2100-2415280	2100-4815280

Graphics

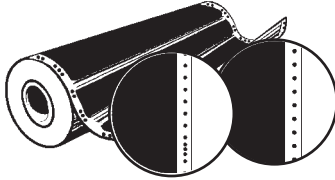
ARLON

SERIES 4550, 4570 & 4500 CAL PLUS FILM

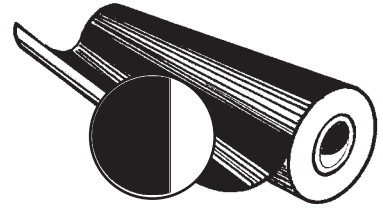

Cal-Plus is a 3 mil calendered vinyl. Its Calon II adhesive system is compatible with the most popular PVC banners and rigid sign faces and is dimensionally stable to resist shrinkage. An excellent value for cost-sensitive projects with an outdoor durability of five years. Also available in 48" width non-perforated rolls. Gloss finish also available in selected colors

Color	Perforated Rolls		Perforated ⁽¹⁾ 30" x 50 yd	Non-Perforated Rolls				
	15" x 50 yd	30" x 50 yd		15" x 50 yd	20" x 50 yd	24" x 50 yd	30" x 50 yd	60" x 50 yd
Red	4550-1515-01	4550-3015-01	4570-3015-01	4500-1515-01	4500-2015-01	4500-2415-01	4500-3015-01	4500-6015-01
White	4550-1515-02	4550-3015-02	4570-3015-02	4500-1515-02	4500-2015-02	4500-2415-02	4500-3015-02	4500-6015-02
Black	4550-1515-03	4550-3015-03	4570-3015-03	4500-1515-03	4500-2015-03	4500-2415-03	4500-3015-03	4500-6015-03
Gold Medal	4550-1515-04	4550-3015-04	4570-3015-04	4500-1515-04	4500-2015-04	4500-2415-04	4500-3015-04	4500-6015-04
Blue	4550-1515-05	4550-3015-05	4570-3015-05	4500-1515-05	4500-2015-05	4500-2415-05	4500-3015-05	4500-6015-05
Yellow	4550-1515-06	4550-3015-06	4570-3015-06	4500-1515-06	4500-2015-06	4500-2415-06	4500-3015-06	4500-6015-06
Silver	4550-1515-07	4550-3015-07	4570-3015-07	4500-1515-07	4500-2015-07	4500-2415-07	4500-3015-07	4500-6015-07
Brown	4550-1515-08	4550-3015-08	4570-3015-08	4500-1515-08	4500-2015-08	4500-2415-08	4500-3015-08	4500-6015-08
Orange	4550-1515-09	4550-3015-09	4570-3015-09	4500-1515-09	4500-2015-09	4500-2415-09	4500-3015-09	4500-6015-09
Purple	4550-1515-10	4550-3015-10	4570-3015-10	4500-1515-10	4500-2015-10	4500-2415-10	4500-3015-10	4500-6015-10
Green	4550-1515-11	4550-3015-11	4570-3015-11	4500-1515-11	4500-2015-11	4500-2415-11	4500-3015-11	4500-6015-11
Burgundy	4550-1515-12	4550-3015-12	4570-3015-12	4500-1515-12	4500-2015-12	4500-2415-12	4500-3015-12	4500-6015-12
Dark Blue	4550-1515-30	4550-3015-30	4570-3015-30	4500-1515-30	4500-2015-30	4500-2415-30	4500-3015-30	4500-6015-30
Rose	4550-1515-31	4550-3015-31	4570-3015-31	4500-1515-31	4500-2015-31	4500-2415-31	4500-3015-31	4500-6015-31
Cotton Candy	4550-1515-32	4550-3015-32	4570-3015-32	4500-1515-32	4500-2015-32	4500-2415-32	4500-3015-32	4500-6015-32
Fire Red	4550-1515-33	4550-3015-33	4570-3015-33	4500-1515-33	4500-2015-33	4500-2415-33	4500-3015-33	4500-6015-33
Cloud Gray	4550-1515-34	4550-3015-34	4570-3015-34	4500-1515-34	4500-2015-34	4500-2415-34	4500-3015-34	4500-6015-34
Imperial Green	4550-1515-35	4550-3015-35	4570-3015-35	4500-1515-35	4500-2015-35	4500-2415-35	4500-3015-35	4500-6015-35
Mission Blue	4550-1515-36	4550-3015-36	4570-3015-36	4500-1515-36	4500-2015-36	4500-2415-36	4500-3015-36	4500-6015-36
Blueberry	4550-1515-37	4550-3015-37	4570-3015-37	4500-1515-37	4500-2015-37	4500-2415-37	4500-3015-37	4500-6015-37
Evening Blue	4550-1515-38	4550-3015-38	4570-3015-38	4500-1515-38	4500-2015-38	4500-2415-38	4500-3015-38	4500-6015-38
Lt. Wedgewood Blue	4550-1515-39	4550-3015-39	4570-3015-39	4500-1515-39	4500-2015-39	4500-2415-39	4500-3015-39	4500-6015-39
Matte Black	4550-1515-40	4550-3015-40	4570-3015-40	4500-1515-40	4500-2015-40	4500-2415-40	4500-3015-40	4500-6015-40
Tusk	4550-1515-41	4550-3015-41	4570-3015-41	4500-1515-41	4500-2015-41	4500-2415-41	4500-3015-41	4500-6015-41
Mint	4550-1515-42	4550-3015-42	4570-3015-42	4500-1515-42	4500-2015-42	4500-2415-42	4500-3015-42	4500-6015-42
Fluorite Green	4550-1515-43	4550-3015-43	4570-3015-43	4500-1515-43	4500-2015-43	4500-2415-43	4500-3015-43	4500-6015-43
Billiard	4550-1515-45	4550-3015-45	4570-3015-45	4500-1515-45	4500-2015-45	4500-2415-45	4500-3015-45	4500-6015-45
Persian Melon	4550-1515-46	4550-3015-46	4570-3015-46	4500-1515-46	4500-2015-46	4500-2415-46	4500-3015-46	4500-6015-46
Matte White	4550-1515-49	4550-3015-49	4570-3015-49	4500-1515-49	4500-2015-49	4500-2415-49	4500-3015-49	4500-6015-49
Royal Blue	4550-1515-50	4550-3015-50	4570-3015-50	4500-1515-50	4500-2015-50	4500-2415-50	4500-3015-50	4500-6015-50
Spring Green	4550-1515-60	4550-3015-60	4570-3015-60	4500-1515-60	4500-2015-60	4500-2415-60	4500-3015-60	4500-6015-60
Medium Green	4550-1515-61	4550-3015-61	4570-3015-61	4500-1515-61	4500-2015-61	4500-2415-61	4500-3015-61	4500-6015-61
Daisy Yellow	4550-1515-68	4550-3015-68	4570-3015-68	4500-1515-68	4500-2015-68	4500-2415-68	4500-3015-68	4500-6015-68
Teal	4550-1515-71	4550-3015-71	4570-3015-71	4500-1515-71	4500-2015-71	4500-2415-71	4500-3015-71	4500-6015-71

NOTE: ⁽¹⁾ 1/2" Perforated pattern.

INTERSTATE ELECTRIC CO., INC.

2240 Yates Ave., Commerce, CA 90040 • 5435 Procyon, #100, Las Vegas, NV 89118 • 6860 Goodyear Rd., Benicia, CA 94510

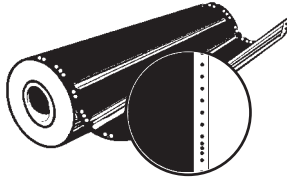

SERIES 1950 & 1900 PROMOCAL GLOSS FILM

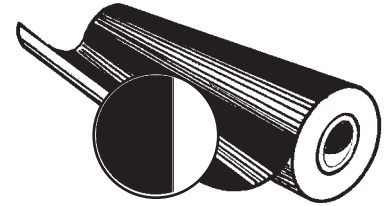

PromoCal Gloss is a 3 mil calendered polymeric PVC vinyl applicable for general substrates, banners and interior graphics with superior cutting and weeding for improved productivity. Recommended for interior use with durability of three to five years. Non-perforated 20", 24", 48" and 60" rolls also available.

Color	Perforated Rolls	
	15" x 50 yd	30" x 50 yd
Red	1950-1515101	1950-3015101
White	1950-1515102	1950-3015102
Black	1950-1515103	1950-3015103
Gold	1950-1515104	1950-3015104
Blue	1950-1515105	1950-3015105
Yellow	1950-1515106	1950-3015106
Silver	1950-1515107	1950-3015107
Brown	1950-1515108	1950-3015108
Orange	1950-1515109	1950-3015109
Royal Purple	1950-1515110	1950-3015110
Green	1950-1515111	1950-3015111
Burgundy	1950-1515112	1950-3015112
Tomato Red	1950-1515114	1950-3015114

Color	Perforated Rolls	
	15" x 50 yd	30" x 50 yd
Fire Red	1950-1515118	1950-3015118
Light Blue	1950-1515122	1950-3015122
Sapphire Blue	1950-1515124	1950-3015124
Light Navy	1950-1515125	1950-3015125
Navy Blue	1950-1515126	1950-3015126
Emerald Green	1950-1515132	1950-3015132
Bright Green	1950-1515136	1950-3015136
Daisy Yellow	1950-1515140	1950-3015140
Dark Pink	1950-1515150	1950-3015150
Light Gray	1950-1515160	1950-3015160
Sunflower	1950-1515164	1950-3015164
Medium Gray	1950-1515168	1950-3015168
Teal	1950-1515171	1950-3015171

SPECIALTY FILMS

FLUORESCENT VINYL FILM

Multi-laminated cast vinyl with high-intensity color for signs, graphics and displays. UV stabilized surface protects against sunlight fading. Outdoor durability of one year.

Color	Perforated Rolls	
	15" x 10 yd	15" x 50 yd
Green	2750-1503-92	2750-1515-92
Red	2750-1503-93	2750-1515-93
Orange	2750-1503-94	2750-1515-94
Yellow	2750-1503-95	2750-1515-95
Pink	2750-1503-97	2750-1515-97

METALLIZED POLYESTER FILM

Brilliant gold and lustrous silver metalized polyester mirror or brushed finished film designed for indoor applications. Easy to handle with the workability of vinyl. Metalized film has a clear and permanent adhesive.

Color	Perforated Rolls			
	Mirror Finish		Brushed Finish	
	15" x 10 yd	15" x 50 yd	15" x 10 yd	15" x 50 yd
Gold	2850-1503-04	2850-1515-04	3950-1503-04	3950-1515-04
Silver	2850-1503-07	2850-1515-07	3950-1503-07	3950-1515-07

DRAWING AND POUNCING PAPER

20# bright white, resists perforated hole tearing.

Color	Perforated Rolls		
	15" x 500 ft	19" x 300 ft	30" x 300 ft
White	3050-1550-02	3050-1930-02	3050-3030-02

CAL-MASK STENCIL FILM

Specially formulated white calendered vinyl for cut-out stenciling.

Color	Perforated Rolls	
	15" x 50 yd	30" x 50 yd
White	2950-1515-02	2950-3015-02

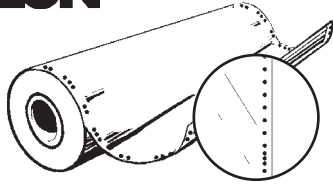
ARLON

SERIES 2550 & 2500 TRANSLUCENT FILM

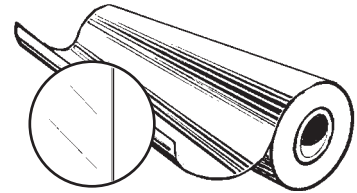

Translucent 2 mil cast vinyl. Its unique Colan II adhesive system ensures that the translucent vinyls remain bonded to outdoor illuminated sign faces. Uniformity of color within roll and from lot to lot and non-directional sensitivity allows character nesting which saves time and materials. Other specialty colors also available in limited sizes. Outdoor durability of seven years.

Color	Perforated Rolls				Non-Perforated Rolls			
	15" x 10 yd	15" x 50 yd	30" x 10 yd	30" x 50 yd	24" x 10 yd	24" x 50 yd	48" x 10 yd	48" x 50 yd
Ivory	2550-1503-05	2550-1515-05	2550-3003-05	2550-3015-05	2500-2403-05	2500-2415-05	2500-4803-05	2500-4815-05
Yellow	2550-1503-15	2550-1515-15	2550-3003-15	2550-3015-15	2500-2403-15	2500-2415-15	2500-4803-15	2500-4815-15
White	2550-1503-20	2550-1515-20	2550-3003-20	2550-3015-20	2500-2403-20	2500-2415-20	2500-4803-20	2500-4815-20
Black ⁽²⁾	2550-1503-22	2550-1515-22	2550-3003-22	2550-3015-22	2500-2403-22	2500-2415-22	2500-4803-22	2500-4815-22
Sunflower	2550-1503-25	2550-1515-25	2550-3003-25	2550-3015-25	2500-2403-25	2500-2415-25	2500-4803-25	2500-4815-25
Green	2550-1503-26	2550-1515-26	2550-3003-26	2550-3015-26	2500-2403-26	2500-2415-26	2500-4803-26	2500-4815-26
Red	2550-1503-33	2550-1515-33	2550-3003-33	2550-3015-33	2500-2403-33	2500-2415-33	2500-4803-33	2500-4815-33
Dark Blue	2550-1503-36	2550-1515-36	2550-3003-36	2550-3015-36	2500-2403-36	2500-2415-36	2500-4803-36	2500-4815-36
Lt. Tomato Red	2550-1503-43	2550-1515-43	2550-3003-43	2550-3015-43	2500-2403-43	2500-2415-43	2500-4803-43	2500-4815-43
Orange	2550-1503-44	2550-1515-44	2550-3003-44	2550-3015-44	2500-2403-44	2500-2415-44	2500-4803-44	2500-4815-44
Burgundy	2550-1503-49	2550-1515-49	2550-3003-49	2550-3015-49	2500-2403-49	2500-2415-49	2500-4803-49	2500-4815-49
Silver Gray	2550-1503-51	2550-1515-51	2550-3003-51	2550-3015-51	2500-2403-51	2500-2415-51	2500-4803-51	2500-4815-51
Cardinal Red ⁽¹⁾	2550-1503253	2550-1515253	2550-3003253	2550-3015253	2500-2403253	2500-2415253	2500-4803253	2500-4815253
Olympic Blue	2550-1503-57	2550-1515-57	2550-3003-57	2550-3015-57	2500-2403-57	2500-2415-57	2500-4803-57	2500-4815-57
Dark Brown	2550-1503-59	2550-1515-59	2550-3003-59	2550-3015-59	2500-2403-59	2500-2415-59	2500-4803-59	2500-4815-59
Rust Brown	2550-1503-63	2550-1515-63	2550-3003-63	2550-3015-63	2500-2403-63	2500-2415-63	2500-4803-63	2500-4815-63
Bright Blue	2550-1503-67	2550-1515-67	2550-3003-67	2550-3015-67	2500-2403-67	2500-2415-67	2500-4803-67	2500-4815-67
Duracolor ⁽²⁾	2550-1503-69	2550-1515-69	2550-3003-69	2550-3015-69	2500-2403-69	2500-2415-69	2500-4803-69	2500-4815-69
Shadow Gray	2550-1503-71	2550-1515-71	2550-3003-71	2550-3015-71	2500-2403-71	2500-2415-71	2500-4803-71	2500-4815-71
Dark Red	2550-1503-73	2550-1515-73	2550-3003-73	2550-3015-73	2500-2403-73	2500-2415-73	2500-4803-73	2500-4815-73
Holly Green	2550-1503-76	2550-1515-76	2550-3003-76	2550-3015-76	2500-2403-76	2500-2415-76	2500-4803-76	2500-4815-76
Vivid Rose	2550-1503-78	2550-1515-78	2550-3003-78	2550-3015-78	2500-2403-78	2500-2415-78	2500-4803-78	2500-4815-78
Regal Red	2550-1503-83	2550-1515-83	2550-3003-83	2550-3015-83	2500-2403-83	2500-2415-83	2500-4803-83	2500-4815-83
Tangerine	2550-1503-84	2550-1515-84	2550-3003-84	2550-3015-84	2500-2403-84	2500-2415-84	2500-4803-84	2500-4815-84
Royal Blue	2550-1503-87	2550-1515-87	2550-3003-87	2550-3015-87	2500-2403-87	2500-2415-87	2500-4803-87	2500-4815-87
Bristol Blue	2550-1503-97	2550-1515-97	2550-3003-97	2550-3015-97	2500-2403-97	2500-2415-97	2500-4803-97	2500-4815-97
Brilliant Green	2550-1503106	2550-1515106	2550-3003106	2550-3015106	2500-2403106	2500-2415106	2500-4803106	2500-4815106
Golden Yellow	2550-1503125	2550-1515125	2550-3003125	2550-3015125	2500-2403125	2500-2415125	2500-4803125	2500-4815125
Intense Blue	2550-1503127	2550-1515127	2550-3003127	2550-3015127	2500-2403127	2500-2415127	2500-4803127	2500-4815127
Plum	2550-1503128	2550-1515128	2550-3003128	2550-3015128	2500-2403128	2500-2415128	2500-4803128	2500-4815128
Gold Metallic	2550-1503131	2550-1515131	2550-3003131	2550-3015131	2500-2403131	2500-2415131	2500-4803131	2500-4815131
Raspberry	2550-1503133	2550-1515133	2550-3003133	2550-3015133	2500-2403133	2500-2415133	2500-4803133	2500-4815133
Poppy Red	2550-1503143	2550-1515143	2550-3003143	2550-3015143	2500-2403143	2500-2415143	2500-4803143	2500-4815143
Lt. Kelly Green	2550-1503146	2550-1515146	2550-3003146	2550-3015146	2500-2403146	2500-2415146	2500-4803146	2500-4815146
Vivid Green	2550-1503156	2550-1515156	2550-3003156	2550-3015156	2500-2403156	2500-2415156	2500-4803156	2500-4815156
Sultan Blue	2550-1503157	2550-1515157	2550-3003157	2550-3015157	2500-2403157	2500-2415157	2500-4803157	2500-4815157

NOTE: ⁽¹⁾ Cardinal Red #53 has been replaced by Cardinal Red #253. ⁽²⁾ Opaque Film, Non Translucent

INTERSTATE ELECTRIC CO., INC.

2240 Yates Ave., Commerce, CA 90040 • 5435 Procyon, #100, Las Vegas, NV 89118 • 6860 Goodyear Rd., Benicia, CA 94510

ARLON

**SERIES 2550 & 2500
TRANSLUCENT FILM cont.**

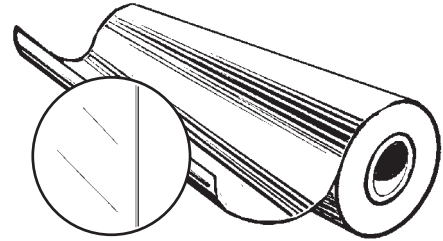
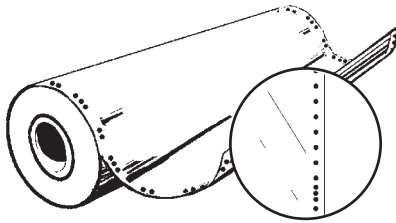

Color	Perforated Rolls			
	15" x 10 yd	15" x 50 yd	30" x 10 yd	30" x 50 yd
Turquoise	2550-1503236	2550-1515236	2550-3003236	2550-3015236
Teal	2550-1503246	2550-1515246	2550-3003246	2550-3015246
Dark Aqua	2550-1503307	2550-1515307	2550-3003307	2550-3015307
Process Blue	2550-1503337	2550-1515337	2550-3003337	2550-3015337
Fire Red	2550-1503415	2550-1515415	2550-3003415	2550-3015415
Bright Yellow	2550-1503525	2550-1515525	2550-3003525	2550-3015525
Imperial Blue	2550-1503557	2550-1515557	2550-3003557	2550-3015557

	Non-Perforated Rolls			
	24" x 10 yd	24" x 50 yd	48" x 10 yd	48" x 50 yd
	2500-2403236	2500-2415236	2500-4803236	2500-4815236
	2500-2403246	2500-2415246	2500-4803246	2500-4815246
	2500-2403307	2500-2415307	2500-4803307	2500-4815307
	2500-2403337	2500-2415337	2500-4803337	2500-4815337
	2500-2403415	2500-2415415	2500-4803415	2500-4815415
	2500-2403525	2500-2415525	2500-4803525	2500-4815525
	2500-2403557	2500-2415557	2500-4803557	2500-4815557

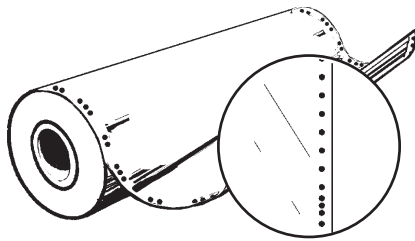

**SERIES 2450 & 2400
REFLECTA-CAL FILM**

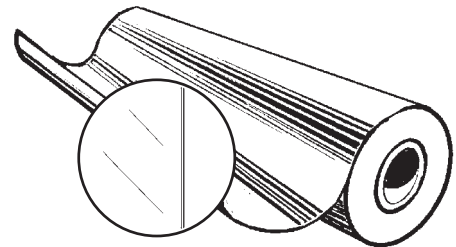

Reflective 6.7 mil cast vinyl. An extremely flexible film that cuts and weeds as well as other reflective films with excellent dimensional stability. Ideal for lettering, striping, die cut logos, highway signage and marine or RV markings. Meets standard specifications such as DOT specification FP-85 - section 718, federal specification L-S-300C and ASTM-D4956-89. Outdoor durability of seven years on flat surfaces and five years on irregular surfaces.

Color	Perforated Rolls			
	15" x 10 yd	15" x 50 yd	30" x 10 yd	30" x 50 yd
Red	2450-1503-01	2450-1515-01	2450-3003-01	2450-3015-01
White	2450-1503-02	2450-1515-02	2450-3003-02	2450-3015-02
Black	2450-1503-03	2450-1515-03	2450-3003-03	2450-3015-03
Gold	2450-1503-04	2450-1515-04	2450-3003-04	2450-3015-04
Blue	2450-1503-05	2450-1515-05	2450-3003-05	2450-3015-05
Yellow	2450-1503-06	2450-1515-06	2450-3003-06	2450-3015-06
Dark Orange	2450-1503-10	2450-1515-10	2450-3003-10	2450-3015-10
Green	2450-1503-11	2450-1515-11	2450-3003-11	2450-3015-11

	Non-Perforated Rolls			
	24" x 10 yd	24" x 50 yd	48" x 10 yd	48" x 50 yd
	2400-2403-01	2400-2415-01	2400-4803-01	2400-4815-01
	2400-2403-02	2400-2415-02	2400-4803-02	2400-4815-02
	2400-2403-03	2400-2415-03	2400-4803-03	2400-4815-03
	2400-2403-04	2400-2415-04	2400-4803-04	2400-4815-04
	2400-2403-05	2400-2415-05	2400-4803-05	2400-4815-05
	2400-2403-06	2400-2415-06	2400-4803-06	2400-4815-06
	2400-2403-10	2400-2415-10	2400-4803-10	2400-4815-10
	2400-2403-11	2400-2415-11	2400-4803-11	2400-4815-11

Graphics

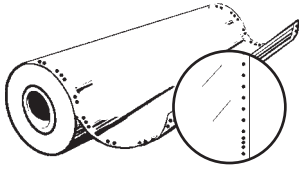

NESCHEN PRO-GLOSS FILM

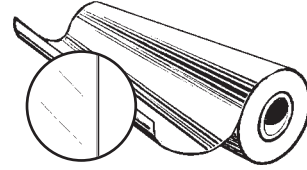

Pro Gloss is a high-gloss 3 mil polished polymeric flexible calendared film that features superior weeding and transfer characteristics over competitive economical brands. Recommended for use where a high quality marking film requiring flexibility, durability and resistance to sunlight is essential. Can be used for architectural signage, commercial/real estate signage, point-of-purchase graphics and decals. 5 year durability under normal exposure. Available in other widths up to 60". Sold by the roll.

Other types of Neschen vinyl film also available.

Color	Perforated Rolls		Non-Perforated Rolls			Reference Number
	15" x 50 yd	30" x 50 yd	20" x 50 yd	24" x 50 yd	30" x 50 yd	
White	1550P-5100	3050P-5100	2050N-5100	2450N-5100	3050N-5100	010
Black	1550P-5101	3050P-5101	2050N-5101	2450N-5101	3050N-5101	070
Clear	1550P-5102	3050P-5102	2050N-5102	2450N-5102	3050N-5102	000
Gray	1550P-5103	3050P-5103	2050N-5103	2450N-5103	3050N-5103	071
Midnight Blue	1550P-5104	3050P-5104	2050N-5104	2450N-5104	3050N-5104	050
Sapphire Blue	1550P-5105	3050P-5105	2050N-5105	2450N-5105	3050N-5105	049
Vivid Blue	1550P-5106	3050P-5106	2050N-5106	2450N-5106	3050N-5106	098
Ocean Blue	1550P-5107	3050P-5107	2050N-5107	2450N-5107	3050N-5107	052
Dark Green	1550P-5108	3050P-5108	2050N-5108	2450N-5108	3050N-5108	613
Green	1550P-5109	3050P-5109	2050N-5109	2450N-5109	3050N-5109	061
Kelly Green	1550P-5110	3050P-5110	2050N-5110	2450N-5110	3050N-5110	062
Dark Yellow	1550P-5111	3050P-5111	2050N-5111	2450N-5111	3050N-5111	020
Lemon	1550P-5112	3050P-5112	2050N-5112	2450N-5112	3050N-5112	025
Daffodil	1550P-5113	3050P-5113	2050N-5113	2450N-5113	3050N-5113	021
Brown	1550P-5114	3050P-5114	2050N-5114	2450N-5114	3050N-5114	080
Beige	1550P-5115	3050P-5115	2050N-5115	2450N-5115	3050N-5115	082
Burgundy	1550P-5116	3050P-5116	2050N-5116	2450N-5116	3050N-5116	312
Cranberry	1550P-5117	3050P-5117	2050N-5117	2450N-5117	3050N-5117	030
Cherry	1550P-5118	3050P-5118	2050N-5118	2450N-5118	3050N-5118	031
Tomato Red	1550P-5119	3050P-5119	2050N-5119	2450N-5119	3050N-5119	032
Orange	1550P-5120	3050P-5120	2050N-5120	2450N-5120	3050N-5120	034
Purple	1550P-5121	3050P-5121	2050N-5121	2450N-5121	3050N-5121	404
Gold	1550P-5122	3050P-5122	2050N-5122	2450N-5122	3050N-5122	091
Silver	1550P-5123	3050P-5123	2050N-5123	2450N-5123	3050N-5123	090



SERIES 3630 3M SCOTCHCAL TRANSLUCENT FILM

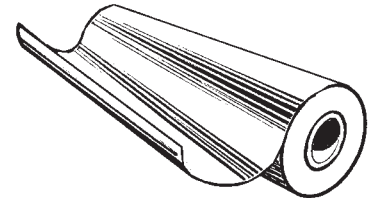

Durable, dimensionally stable translucent films designed for internally illuminated sign faces, window graphics or on white substrates. Films are uniform in color with a low surface gloss in either reflected or transmitted light. Intended for flat acrylic, polycarbonate, butyrate, fiberglass, glass, Panaflex series 945 and other prepared substrates. Can be applied to interior or exterior surfaces of substrates listed. Over-laminating with series 3640 products enhances cleaning and durability. Five year outdoor performance can be expected, four years in hot sunny areas.

Non-Perforated Rolls				
Color	24" x 10 yd	24" x 50 yd	48" x 10 yd	48" x 50 yd
Ivory	3630-05-2410	3630-05-2450	3630-05-4810	3630-05-4850
Yellow	3630-15-2410	3630-15-2450	3630-15-4810	3630-15-4850
White	3630-20-2410	3630-20-2450	3630-20-4810	3630-20-4850
Black	3630-22-2410	3630-22-2450	3630-22-4810	3630-22-4850
Sunflower	3630-25-2410	3630-25-2450	3630-25-4810	3630-25-4850
Green	3630-26-2410	3630-26-2450	3630-26-4810	3630-26-4850
Red	3630-33-2410	3630-33-2450	3630-33-4810	3630-33-4850
Blue	3630-36-2410	3630-36-2450	3630-36-4810	3630-36-4850
Lt. Tomato Red	3630-43-2410	3630-43-2450	3630-43-4810	3630-43-4850
Orange	3630-44-2410	3630-44-2450	3630-44-4810	3630-44-4850
Burgundy	3630-49-2410	3630-49-2450	3630-49-4810	3630-49-4850
Silver Grey	3630-51-2410	3630-51-2450	3630-51-4810	3630-51-4850
Cardinal Red	3630-53-2410	3630-53-2450	3630-53-4810	3630-53-4850
Olympic Blue	3630-57-2410	3630-57-2450	3630-57-4810	3630-57-4850
Dark Brown	3630-59-2410	3630-59-2450	3630-59-4810	3630-59-4850
Slate Grey	3630-61-2410	3630-61-2450	3630-61-4810	3630-61-4850
Rust Brown	3630-63-2410	3630-63-2450	3630-63-4810	3630-63-4850
Rose Mauve	3630-68-2410	3630-68-2450	3630-68-4810	3630-68-4850
Duranodic	3630-69-2410	3630-69-2450	3630-69-4810	3630-69-4850
Shadow Gray	3630-71-2410	3630-71-2450	3630-71-4810	3630-71-4850
Dark Red	3630-73-2410	3630-73-2450	3630-73-4810	3630-73-4850
Kumquat Orange	3630-74-2410	3630-74-2450	3630-74-4810	3630-74-4850
Marigold	3630-75-2410	3630-75-2450	3630-75-4810	3630-75-4850
Holly Green	3630-76-2410	3630-76-2450	3630-76-4810	3630-76-4850
Vivid Rose	3630-78-2410	3630-78-2450	3630-78-4810	3630-78-4850
Regal Red	3630-83-2410	3630-83-2450	3630-83-4810	3630-83-4850
Tangerine	3630-84-2410	3630-84-2450	3630-84-4810	3630-84-4850
Royal Blue	3630-87-2410	3630-87-2450	3630-87-4810	3630-87-4850
Bristol Blue	3630-97-2410	3630-97-2450	3630-97-4810	3630-97-4850

Non-Perforated Rolls				
Color	24" x 10 yd	24" x 50 yd	48" x 10 yd	48" x 50 yd
Pink	3630108-2410	3630108-2450	3630108-4810	3630108-4850
Lt. Rust Brown	3630109-2410	3630109-2450	3630109-4810	3630109-4850
Lt. Lemon Yellow	3630115-2410	3630115-2450	3630115-4810	3630115-4850
Brit. Jade Green	3630116-2410	3630116-2450	3630116-4810	3630116-4850
Intense Magenta	3630118-2410	3630118-2450	3630118-4810	3630118-4850
Silver ⁽¹⁾	3630121-2410	3630121-2450	3630121-4810	3630121-4850
Golden Yellow	3630125-2410	3630125-2450	3630125-4810	3630125-4850
Dk. Emerald Green	3630126-2410	3630126-2450	3630126-4810	3630126-4850
Intense Blue	3630127-2410	3630127-2450	3630127-4810	3630127-4850
Plum Purple	3630128-2410	3630128-2450	3630128-4810	3630128-4850
Bronze	3630129-2410	3630129-2450	3630129-4810	3630129-4850
Gold Metallic ⁽¹⁾	3630131-2410	3630131-2450	3630131-4810	3630131-4850
Raspberry	3630133-2410	3630133-2450	3630133-4810	3630133-4850
Lime Green	3630136-2410	3630136-2450	3630136-4810	3630136-4850
European Blue	3630137-2410	3630137-2450	3630137-4810	3630137-4850
Gold Nugget	3630141-2410	3630141-2450	3630141-4810	3630141-4850
Poppy Red	3630143-2410	3630143-2450	3630143-4810	3630143-4850
Lt. Kelly Green	3630146-2410	3630146-2450	3630146-4810	3630146-4850
Lt. European Blue	3630147-2410	3630147-2450	3630147-4810	3630147-4850
Lt. Beige	3630149-2410	3630149-2450	3630149-4810	3630149-4850
Vivid Green	3630156-2410	3630156-2450	3630156-4810	3630156-4850
Sultan Blue	3630157-2410	3630157-2450	3630157-4810	3630157-4850
Bright Blue	3630167-2410	3630167-2450	3630167-4810	3630167-4850
Turquoise	3630236-2410	3630236-2450	3630236-4810	3630236-4850
Teal Green	3630246-2410	3630246-2450	3630246-4810	3630246-4850
Evening Blue	3630317-2410	3630317-2450	3630317-4810	3630317-4850
Process Blue	3630337-2410	3630337-2450	3630337-4810	3630337-4850

NOTE: ⁽¹⁾ 3 years expected life.

Graphics



SERIES 7725
3M SCOTCHCAL ELECTROCUT FILM

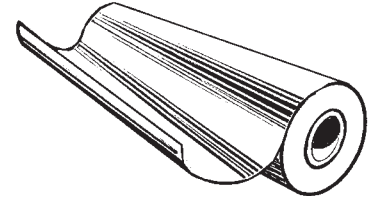

These are durable, stable, glossy (except matte) vinyl films for the production of electronically cut graphics. Recommended for flat and simple curved surfaces. Colorless adhesive is suitable for application to glass surfaces. Expected outdoor performance is five years.

Series 7725 SE Dusted and Frosted Crystal films are designed for window graphics and internally illuminated displays. Films have uniformed color in both reflected and transmitted light with low gloss to eliminate glare. These films are intended for use on flat clear substrates such as glass, acrylic or polycarbonates. Dusted Crystal has an acid-etched look where Frosted colors have a sand-blasted appearance. Application of Dusted Crystal between two sheets of glass is not recommended. Screen printing is not recommended nor warranted. Expected outdoor performance is three years.

Graphics

Color	Non-Perforated Rolls			
	24" x 10 yd	24" x 50 yd	48" x 10 yd	48" x 50 yd
White	7725-10-2410	7725-10-2450	7725-10-4810	7725-10-4850
Pearl Grey	7725-11-2410	7725-11-2450	7725-11-4810	7725-11-4850
Black	7725-12-2410	7725-12-2450	7725-12-4810	7725-12-4850
Tomato Red	7725-13-2410	7725-13-2450	7725-13-4810	7725-13-4850
Bright Orange	7725-14-2410	7725-14-2450	7725-14-4810	7725-14-4850
Bright Yellow	7725-15-2410	7725-15-2450	7725-15-4810	7725-15-4850
Vivid Blue	7725-17-2410	7725-17-2450	7725-17-4810	7725-17-4850
Deep/Mdgy.Bn.	7725-19-2410	7725-19-2450	7725-19-4810	7725-19-4850
Matte White	7725-20-2410	7725-20-2450	7725-20-4810	7725-20-4850
Matte Black	7725-22-2410	7725-22-2450	7725-22-4810	7725-22-4850
Terra Cotta	7725-24-2410	7725-24-2450	7725-24-4810	7725-24-4850
Sunflower	7725-25-2410	7725-25-2450	7725-25-4810	7725-25-4850
Indigo	7725-27-2410	7725-27-2450	7725-27-4810	7725-27-4850
Russet Brown	7725-29-2410	7725-29-2450	7725-29-4810	7725-29-4850
Medium Grey	7725-31-2410	7725-31-2450	7725-31-4810	7725-31-4850
Sapphire Blue	7725-37-2410	7725-37-2450	7725-37-4810	7725-37-4850
Royal Purple	7725-38-2410	7725-38-2450	7725-38-4810	7725-38-4850
Tan	7725-39-2410	7725-39-2450	7725-39-4810	7725-39-4850
Dark Grey	7725-41-2410	7725-41-2450	7725-41-4810	7725-41-4850
Kelly Green	7725-46-2410	7725-46-2450	7725-46-4810	7725-46-4850
Intense Blue	7725-47-2410	7725-47-2450	7725-47-4810	7725-47-4850
Purple	7725-48-2410	7725-48-2450	7725-48-4810	7725-48-4850
Beige	7725-49-2410	7725-49-2450	7725-49-4810	7725-49-4850
Cardinal Red	7725-53-2410	7725-53-2450	7725-53-4810	7725-53-4850
Light Orange	7725-54-2410	7725-54-2450	7725-54-4810	7725-54-4850
Dark Green	7725-56-2410	7725-56-2450	7725-56-4810	7725-56-4850
Olympic Blue	7725-57-2410	7725-57-2450	7725-57-4810	7725-57-4850
Burgundy	7725-58-2410	7725-58-2450	7725-58-4810	7725-58-4850
Putty	7725-59-2410	7725-59-2450	7725-59-4810	7725-59-4850
Geranium	7725-63-2410	7725-63-2450	7725-63-4810	7725-63-4850
Apricot	7725-64-2410	7725-64-2450	7725-64-4810	7725-64-4850
Forest Green	7725-66-2410	7725-66-2450	7725-66-4810	7725-66-4850
Peacock Blue	7725-77-2410	7725-77-2450	7725-77-4810	7725-77-4850
Vista Yellow	7725-85-2410	7725-85-2450	7725-85-4810	7725-85-4850

Color	Non-Perforated Rolls			
	24" x 10 yd	24" x 50 yd	48" x 10 yd	48" x 50 yd
Robin Egg Blue	7725-86-2410	7725-86-2450	7725-86-4810	7725-86-4850
Violet	7725-88-2410	7725-88-2450	7725-88-4810	7725-88-4850
Sandstone	7725-89-2410	7725-89-2450	7725-89-4810	7725-89-4850
Antique White	7725-90-2410	7725-90-2450	7725-90-4810	7725-90-4850
Teal	7725-96-2410	7725-96-2450	7725-96-4810	7725-96-4850
Dark Violet	7725-98-2410	7725-98-2450	7725-98-4810	7725-98-4850
Fawn	7725-99-2410	7725-99-2450	7725-99-4810	7725-99-4850
Magenta	7725103-2410	7725103-2450	7725103-4810	7725103-4850
Harvest Gold	7725105-2410	7725105-2450	7725105-4810	7725105-4850
Transparent	7725114-2410	7725114-2450	7725114-4810	7725114-4850
Satin Aluminum	7725120-2410	7725120-2450	7725120-4810	7725120-4850
Egg Shell	7725130-2410	7725130-2450	7725130-4810	7725130-4850
Satin Gold	7725131-2410	7725131-2450	7725131-4810	7725131-4850
Saddle Brown	7725139-2410	7725139-2450	7725139-4810	7725139-4850
Salmon Pink	7725173-2410	7725173-2450	7725173-4810	7725173-4850
Aqua	7725176-2410	7725176-2450	7725176-4810	7725176-4850
Shadow Blue	7725177-2410	7725177-2450	7725177-4810	7725177-4850
Bright Green	7725186-2410	7725186-2450	7725186-4810	7725186-4850
Wedgewood Blue	7725187-2410	7725187-2450	7725187-4810	7725187-4850
Mauve	7725193-2410	7725193-2450	7725193-4810	7725193-4850
Apple Green	7725196-2410	7725196-2450	7725196-4810	7725196-4850
Light Navy	7725197-2410	7725197-2450	7725197-4810	7725197-4850
Perf. Match Red	7725263-2410	7725263-2450	7725263-4810	7725263-4850
Proc. Magenta	7725273-2410	7725273-2450	7725273-4810	7725273-4850
Bottle Green	7725276-2410	7725276-2450	7725276-4810	7725276-4850
Dark Aqua	7725307-2410	7725307-2450	7725307-4810	7725307-4850
Bermuda Blue	7725357-2410	7725357-2450	7725357-4810	7725357-4850

SERIES 7725 SE

Color	Non-Perforated Rolls			
	24" x 10 yd	24" x 50 yd	48" x 10 yd	48" x 50 yd
Dusted Crystal	7725314-2410	7725314-2450	7725314-4810	7725314-4850
Frosted Rose	7725323-2410	7725323-2450	7725323-4810	7725323-4850
Frosted Clear	7725324-2410	7725324-2450	7725324-4810	7725324-4850
Frosted Mint	7725326-2410	7725326-2450	7725326-4810	7725326-4850
Frosted Blue/Mist	7725327-2410	7725327-2450	7725327-4810	7725327-4850
Frosted Gold	7725331-2410	7725331-2450	7725331-4810	7725331-4850

3M

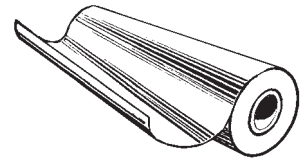

SERIES 180
3M SCOTCHCAL CONTROLTAC PLUS FILM

Controltac Plus series films are durable and dimensionally stable glossy vinyl films which may be screen printed on for attractive multicolored signs, labels, markings, striping and emblems for commercial and industrial use which must withstand severe weather and handling. Intended for use on flat surfaces with or without rivets and corrugated surfaces. Not intended where markings may be subjected to petrochemical spillage. These films have excellent hiding power. 3M developed a technology which allows positioning and repositioning of Controltac Plus film. It is a mechanical rather than an adhesive feature that is activated when pressure is applied to the film surface by a squeegee. Performance of five to seven years can be expected. Other widths also available.

Color	Non-Perforated Rolls				
	24" x 10 yd	24" x 50 yd	36" x 50 yd	48" x 10 yd	48" x 50 yd
White	180-10-2410	180-10-2450	180-10-3650	180-10-4810	180-10-4850
Black	180-12-2410	180-12-2450	180-12-3650	180-12-4810	180-12-4850
Tomato Red	180-13-2410	180-13-2450	180-13-3650	180-13-4810	180-13-4850
Bright Orange	180-14-2410	180-14-2450	180-14-3650	180-14-4810	180-14-4850
Bright Yellow ⁽¹⁾	180-15-2410	180-15-2450	180-15-3650	180-15-4810	180-15-4850
Vivid Blue	180-17-2410	180-17-2450	180-17-3650	180-17-4810	180-17-4850
Deep/Matg.Bln.	180-19-2410	180-19-2450	180-19-3650	180-19-4810	180-19-4850
Matte Black	180-22-2410	180-22-2450	180-22-3650	180-22-4810	180-22-4850
Deep Red	180-23-2410	180-23-2450	180-23-3650	180-23-4810	180-23-4850
Sunflower ⁽¹⁾	180-25-2410	180-25-2450	180-25-3650	180-25-4810	180-25-4850
Indigo	180-27-2410	180-27-2450	180-27-3650	180-27-4810	180-27-4850
Russet Brown	180-29-2410	180-29-2450	180-29-3650	180-29-4810	180-29-4850
Medium Grey	180-31-2410	180-31-2450	180-31-3650	180-31-4810	180-31-4850
Sapphire Blue	180-37-2410	180-37-2450	180-37-3650	180-37-4810	180-37-4850
Royal Purple	180-38-2410	180-38-2450	180-38-3650	180-38-4810	180-38-4850
Tan	180-39-2410	180-39-2450	180-39-3650	180-39-4810	180-39-4850
Dark Grey	180-41-2410	180-41-2450	180-41-3650	180-41-4810	180-41-4850
Kelly Green	180-46-2410	180-46-2450	180-46-3650	180-46-4810	180-46-4850
Intense Blue	180-47-2410	180-47-2450	180-47-3650	180-47-4810	180-47-4850
Beige	180-49-2410	180-49-2450	180-49-3650	180-49-4810	180-49-4850
Cardinal Red	180-53-2410	180-53-2450	180-53-3650	180-53-4810	180-53-4850
Light Orange	180-54-2410	180-54-2450	180-54-3650	180-54-4810	180-54-4850
Dark Green	180-56-2410	180-56-2450	180-56-3650	180-56-4810	180-56-4850
Olympic Blue	180-57-2410	180-57-2450	180-57-3650	180-57-4810	180-57-4850
Burgundy	180-58-2410	180-58-2450	180-58-3650	180-58-4810	180-58-4850
Geranium	180-63-2410	180-63-2450	180-63-3650	180-63-4810	180-63-4850
Peacock Blue	180-77-2410	180-77-2450	180-77-3650	180-77-4810	180-77-4850

NOTE: ⁽¹⁾ Significantly less opacity than others.

Color	Non-Perforated Rolls		
	24" x 10 yd	48" x 10 yd	48" x 50 yd
Violet	180-88-2410	180-88-4810	180-88-4850
Teal	180-96-2410	180-96-4810	180-96-4850
Dark Violet	180-98-2410	180-98-4810	180-98-4850
Magenta	180-103-2410	180-103-4810	180-103-4850
Transparent	180-114-2410	180-114-4810	180-114-4850
Satin Aluminum	180-120-2410	180-120-4810	180-120-4850
Satin Gold	180-131-2410	180-131-4810	180-131-4850
Salmon Pink	180-173-2410	180-173-4810	180-173-4850
Aqua	180-176-2410	180-176-4810	180-176-4850
Bright Green	180-186-2410	180-186-4810	180-186-4850
Mauve	180-193-2410	180-193-4810	180-193-4850
Apple Green	180-196-2410	180-196-4810	180-196-4850
Slate Mtl.	180-201-2410	180-201-4810	180-201-4850
Red Mtl.	180-203-2410	180-203-4810	180-203-4850
Charcoal Mtl.	180-211-2410	180-211-4810	180-211-4850
Sage Green Mtl.	180-216-2410	180-216-4810	180-216-4850
Dark Blue Mtl.	180-217-2410	180-217-4810	180-217-4850
Lt. Silver Mtl.	180-220-2410	180-220-4810	180-220-4850
Grey Mtl.	180-221-2410	180-221-4810	180-221-4850
Br. Blue Mtl.	180-227-2410	180-227-4810	180-227-4850
Dk. Burg. Mtl.	180-228-2410	180-228-4810	180-228-4850
Copper Mtl.	180-229-2410	180-229-4810	180-229-4850
Silver Blue Mtl.	180-237-2410	180-237-4810	180-237-4850
Choc. Bm. Mtl.	180-239-2410	180-239-4810	180-239-4850
Gold Mtl.	180-241-2410	180-241-4810	180-241-4850
Dark Aqua	180-307-2410	180-307-4810	180-307-4850

Graphics

SERIES 160
3M SCOTCHCAL CONTROLTAC PLUS FILM

160-30/32 film is tough, permanent and scuff resistant which will withstand severe weather and handling. Because a black pigmented adhesive is used, this film has excellent hiding power. Adhesive allows for removal with heat for up to five years with little or no residue from most surfaces. Performance of five years can be expected.

160-80 film is white, tough, ink and enamel receptive and permanent scuff resistant. It may be screened, letterpress printed on or hand brushed. Performance of four years can be expected.

Color	Non-Perforated Rolls	
	24" x 50 yd	48" x 50 yd
White	160-30-2450	160-30-4850
Black	160-32-2450	160-32-4850
Translucent Frost	160-60-2450	160-60-4850
White Enamel Receptive	160-80-2450	160-80-4850

Commerce: 323.803.2000 / 800.225.5432 (CALL IEC) / Fax 323.803.2019

Las Vegas: 702.795.2233 / 800.772.4141 / Fax 702.798.9911 • Benicia: 707.747.5115 / 800.824.0099 / Fax 707.747.1266

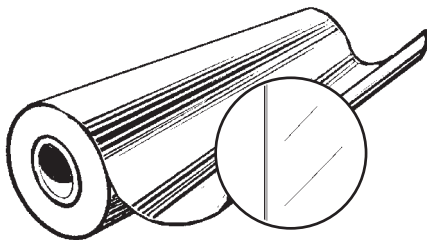

3M SCOTCHCAL FILM

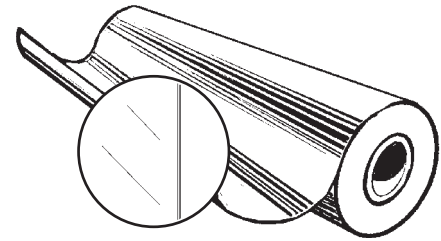

SERIES 3635 LIGHT CONTROL FILM

Series 3635-10/12 films are designed for blocking out light when applied to internally illuminated signs. These opaque films are intended for application on flat acrylic and polycarbonate. 3635-10 is white on the face side and black on the adhesive side. 3635-12 is black on the face side and white on the adhesive side.

Series 3635-30/70 films are designed for use as light diffusers when applied to the second surface of internally illuminated signs. 3635-30 has 30% light transmission while 3635-70 has 60% light transmission. These films are uniformly white in both reflective and transmitted light and are intended for application on flat acrylic and polycarbonate. Not intended nor warranted for application to the first (front) surface of sign faces.

Series 3635-91 Day/Night film is an exterior, medium term durability film with a nominal light transmission of 47% used to produce the appearance of dark graphics in daylight while producing white or colored graphics at night on internally illuminated signs. Can be applied to a flat first or second rivet free surface. Can also be applied to most sign related substrates. See 3M literature for detailed recommendations.

Color	Non-Perforated Rolls	
	48" x 10 yd	48" x 50 yd
White Blockout	3635-10-4810	3635-10-4850
Black Blockout	3635-12-4810	3635-12-4850
Matte White Blockout	363520B-4810	363520B-4850
Matte Black Blockout	363522B-4810	363522B-4850
Diffused White 30%	3635-30-4810	3635-30-4850
Diffused White 60%	3635-70-4810	3635-70-4850
Day/Night	3635-91-4810	3635-91-4850
Light Enhancement Film	3635100-4810	3635100-4850

SERIES 3640 & 3642 OVERLAY FILM

Series 3640 and 3642 films are durable, dimensionally stable translucent films which are designed for the protection of graphics used on internally illuminated or window graphics applications. These films are intended for application to 3M Scotchcal films which are applied to flat acrylic, butyrate, fiberglass, glass and Panaflex series 945 substrates.

Series 3640 has a high gloss surface while series 3642 has a matte surface. When properly applied to the substrates listed above, these products impart outstanding resistance to dirt and other environmental factors including many strong solvents. Expected outdoor performance is 9 years on vertical applications (6 years in very hot areas) and 5 years on non-vertical applications (4 years in very hot areas).

Color	Non-Perforated Rolls	
	48" x 10 yd	48" x 50 yd
High Gloss	3640114-4810	3640114-4850
Matte	3642114-4810	3642114-4850

DUAL-COLOR FILM

Also available in a variety of colors.

SERIES 3690 MARKING FILM

These durable, glossy, vinyl films are intended for markings and striping that must withstand severe weather and handling. Films have a black aggressive pressure sensitive adhesive which adheres to moderately rough surfaces and provides good hiding power. Not recommended for corrugated surfaces, rivets or use where markings may be subjected to petro-chemical spillage. Performance of five years can be expected.

SERIES 3470 PLUS MARKING FILM

Tough permanent scuff resistant films for the production of markings and POP displays for exterior and interior use on flat surfaces with or without rivets. Not intended for irregular surfaces or petroleum markings. Adhesive allows removal up to two years with little adhesive residue.

Color	Non-Perforated Rolls			
	24" x 50 yd	36" x 50 yd	48" x 10 yd	48" x 50 yd
White	3470-2450	3470-3650	3470-4810	3470-4850
Black	3475-2450	3475-3650	3475-4810	3475-4850

Color	Non-Perforated Rolls	
	24" x 50 yd	48" x 50 yd
White	3690-10-2450	3690-10-4850
Black	3690-12-2450	3690-12-4850



SERIES 3650 3M SCOTCHCAL GRAPHIC MARKING FILM

Durable, dimensionally stable glossy vinyl films intended for the production of attractive signs, labels, markings, striping and emblems for commercial and industrial applications which must withstand severe handling and weather conditions as well as occasional spills of petroleum products. These films are intended for use on flat surfaces with and without rivets. Applications to corrugated surfaces is not recommended.

3M has developed a technology which allows Scotchcal Plus series 3650 to be both positionable and repositionable. This technology is a mechanical feature rather than an adhesive property. It allows for pressure activated adhesion when pressure is applied to the film surface by a squeegee. Seven year warranty.

Color	Non-Perforated Rolls				
	24" x 10 yd	24" x 50 yd	36" x 50 yd	48" x 10 yd	48" x 50 yd
White	3650-10-2410	3650-10-2450	3650-10-3650	3650-10-4810	3650-10-4850
Black	3650-12-2410	3650-12-2450	3650-12-3650	3650-12-4810	3650-12-4850
Transparent	3650114-2410	3650114-2450	3650114-3650	3650114-4810	3650114-4850

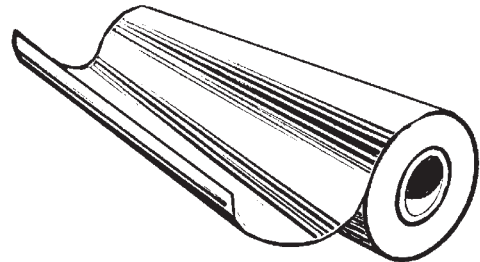

3M SCOTCHLITE REFLECTIVE FILM

SERIES 580 SCOTCHLITE REFLECTIVE FILM

A durable, flexible, enclosed lens reflective sheeting for the production of multicolored markings, displays, signs, truck markings and other markings which have the same appearance in the daytime and at night even when viewed at wide angles. Intended for application to flat surfaces with and without rivets. Not intended for corrugated surfaces or compound curvatures. Expected performance of five to seven years.

Color	Non-Perforated Rolls				
	24" x 10 yd	24" x 50 yd	36" x 50 yd	48" x 10 yd	48" x 50 yd
White	580-10U-2410	580-10U-2450	580-10U-3650	580-10U-4810	580-10U-4850
Orange	580-14-2410	580-14-2450	580-14-3650	580-14-4810	580-14-4850
Gold	580-64-2410	580-64-2450	580-64-3650	580-64-4810	580-64-4850
Yellow	580-71-2410	580-71-2450	580-71-3650	580-71-4810	580-71-4850
Red	580-72-2410	580-72-2450	580-72-3650	580-72-4810	580-72-4850
Blue	580-75-2410	580-75-2450	580-75-3650	580-75-4810	580-75-4850
Light Blue	580-76-2410	580-76-2450	580-76-3650	580-76-4810	580-76-4850
Green	580-77-2410	580-77-2450	580-77-3650	580-77-4810	580-77-4850
Lemon Yellow	580-81-2410	580-81-2450	580-81-3650	580-81-4810	580-81-4850
Ruby Red	580-82-2410	580-82-2450	580-82-3650	580-82-4810	580-82-4850
Charcoal Black	580-85-2410	580-85-2450	580-85-3650	580-85-4810	580-85-4850

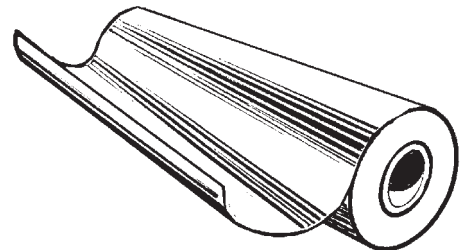

Graphics

SERIES 550 SCOTCHLITE REFLECTIVE SHEETING

Durable enclosed lens reflective sheeting for the production of multicolor emblems and markings. Remains reflective even when totally wet and retains its reflectivity when viewed at wide angles. Intended for application to irregular surfaces such as rivet heads. This sheeting is not recommended for use on corrugated surfaces. Performance of four years can be expected. Other widths also available.

Color	Non-Perforated Rolls			
	24" x 10 yd	24" x 50 yd	48" x 10 yd	48" x 50 yd
White	550-10U-2410	550-10U-2450	550-10U-4810	550-10U-4850

3M

SERIES 639 SCOTCHCAL FILM

This transparent film is intended for the production of attractive labels, markings and nameplates with maximum eye appeal and advertising effectiveness for both interior and exterior applications. Performance of three years can be expected.

Non-Perforated Rolls			
24" x 10 yd	24" x 50 yd	48" x 10 yd	48" x 50 yd
639-2410	639-2450	639-4810	639-4850

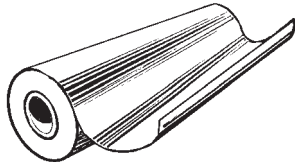

FILM APPLICATORS AND TOOLS

Film applicators for burnishing vinyl materials. Brush is used to work around items such as rivets. Applicators (squeegees) are available in regular duty blue and heavy duty gold (heavy duty applicators last considerably longer). Low friction sleeve slides over squeegee for faster and smoother travel and to protect film surfaces.

Catalog Number	Description	Put Up
MMM-RBA-1	Rivet Brush Applicator	1
MMM-PA-1BLUE	Blue Applicator (Squeegee)	25
MMM-PA-1GOLD	Gold Heavy Duty Applicator (Squeegee)	25
MMM-SA-1	Low Friction Applicator Sleeve	5/100
MMM-391X	Air Release Tool for Vinyl Film	1
MMM-392X	Replacement Point for Release Tool	1



MMM-PA-1BLUE



MMM-SA-1



MMM-RBA-1

SERIES 3900 PRINTING INKS

These silk screening inks are used for decorating Scotchcal and Controltac films. Detailed instruction bulletins on use are available upon request. These inks are for use with Scotchcal series: 160, 180, 181, 3470, 3480, 3630, 3670, 3690, 7725 and 7750 films. Sold by the gallon.

Color/Description	Catalog Number
Yellow	MMM-3902G
White	MMM-3903G
Black	MMM-3905G
Lt. Chrome Yellow	MMM-3912G
Dark Green	MMM-3914G
Lt. Cadmium Red	MMM-3915G
Blue	MMM-3916G
Dark Cadmium Red	MMM-3917G
Gold Metallic	MMM-3919G
Blue-Violet	MMM-3927G
Orange	MMM-3933G
Red-Violet	MMM-3937G
Red-Toned Blue	MMM-3970G
Deep Red	MMM-3971G
Bright Red	MMM-3972G
Toner/Reducer	MMM-9710G
Overprint Clear-Gloss	MMM-3920G
Overprint Clear-Matte	MMM-3930G
Overprint UV Gloss	MMM-9720G
Thinner for 4430R	MMM-CGS-30G
Thinner for Ink	MMM-CGS-60G
Slow Thinner for Ink	MMM-CGS-65G
Edge Sealer	MMM-3950

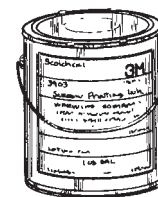

Graphics

COBURN/R TAPE

SPECIAL EFFECT PVC FILMS

Coburn Graphic Films designs and manufactures unique metallized plastic films in a wide variety of eye-catching holographic, diffraction, phosphorescent, mirrored, glitter, prism and other illusionary patterns. For over 30 years, Coburn special effect films have created distinctive signage, decals, packaging, labels, exhibits, toys and novelties.

This 3mil metallized PVC film has a .9mil general purpose clear permanent adhesive on a heavyweight lay flat liner. Indoor durability is long term for most applications. Outdoor durability is limited typically to six to twelve months, depending on application. Exceptionally harsh UV and wet conditions can shorten exterior life. Exterior life can be extended by using a UV protective clear coating and edge sealer. Long-term exterior versions may also be available.

The following are several popular descriptions of the types of product:

MULTI LENS: Metallized PVC films with continual repeat patterns of "three-dimensional" concave or convex lenses. Based on the Fresnel Lens principal, the effect is that of metallic spheres. Available in different lens sizes and colors.

DIFFRACTO-LITE: Metallized holographic and prismatic PVC films. Available in a broad range of light-diffracting patterns.

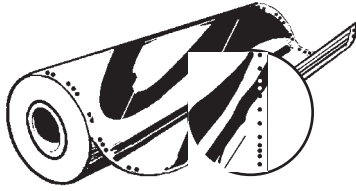

GOLD LEAF FILM

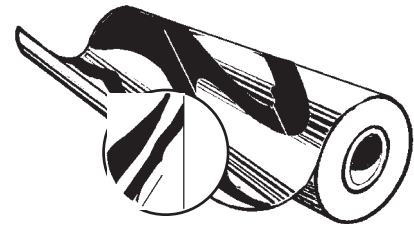

SIGNGOLD

SignGold® is an ultrathin, 1 mil, 22 karat gold leaf film with a permanent self-adhesive for computer-aided sign making. SignGold® signage costs approximately 50% less than labor intensive "hand-gilded" gold leaf and eliminates costly re-gilding every few years. SignGold® may be used outdoors on glass, metal, painted wood, plastic and other commonly used sign making substrates. SignGold® cuts, weeds and applies easier. It also conforms to irregular surfaces and won't curl, crack, fade or peel. Performance of 10 years can be expected. Also available in other widths and patterns.

SIGNGOLD



Burnished Glass Gold

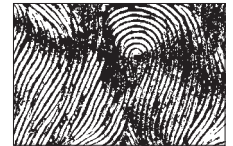

Florentine Swirl Gold

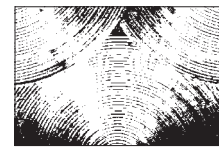

Large Engine Turned Gold

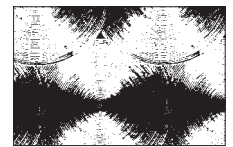

Small Engine Turned Gold



Satin Gold



Surface Matte Gold

Catalog Number	Description/Pattern	Width Inches	Roll Length Yards	Application Surface	Perforated or Un-Perforated
SIG-BRNISH22	Burnished Glass Gold	15"	2	2nd	Perforated
SIG-BRNISH25	Burnished Glass Gold	15"	5	2nd	Perforated
SIG-BRNISH30	Burnished Glass Gold	15"	10	2nd	Perforated
SIG-SG1FS-02	Florentine Swirl Gold	15"	2	1st	Perforated
SIG-SG1FS-05	Florentine Swirl Gold	15"	5	1st	Perforated
SIG-SG1FS-10	Florentine Swirl Gold	15"	10	1st	Perforated
SIG-SG1LET-02	Large Engine Turned Gold	15"	2	1st	Perforated
SIG-SG1LET-05	Large Engine Turned Gold	15"	5	1st	Perforated
SIG-SG1LET-45	Large Engine Turned Gold	24"	5	1st	Un-Perforated
SIG-SG1SET-02	Small Engine Turned Gold	15"	2	1st	Perforated
SIG-SG1SET-05	Small Engine Turned Gold	15"	5	1st	Perforated
SIG-SG1SS-02	Satin Gold	15"	2	1st	Perforated
SIG-SG1SS-05	Satin Gold	15"	5	1st	Perforated
SIG-SURFCE22	Surface Matte Gold	15"	2	2nd	Perforated
SIG-SURFCE25	Surface Matte Gold	15"	5	1st	Perforated
SIG-SNGDI550	Release Liner for SignGold	15"	50	-	Perforated

Graphics

COBURN TMP FILM SERIES

TMP films consist of a 3mil metalized PVC with a .9mil general purpose, clear permanent adhesive on a heavy weight lay flat liner. Smooth and textured metalized plastic (TMP) films offer an array of mirrored, brushed, leaf and other interesting patterns in both gold and silver. Available in 15" x 25' perforated or 24" non-perforated sizes. Sold by the roll.

An ODS Series with 5 year outdoor UV durability is also available.



ROYAL LEAF SIMULATED GOLDLEAF FILM

These perforated sheets are a very realistic imitation of gold leaf. Cuts just as easy as vinyl film. For indoor use only.

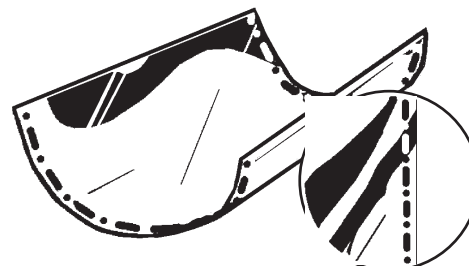

Royal
Leaf

Catalog Number	Dimensions	Put Up
REF-GOLDLEAF	15" x 27"	5 Sheets



"R" APPLICATION TAPE

An economical white, translucent, standard weight saturated paper with high-tack adhesive for clean pick up and transfer of small and medium size lettering and graphics. Sold by the 100 yard roll.

Catalog Number	Description	Width (Inches)
4075-1.25	White Paper	1.25
4075-2.25	White Paper	2.25
4075-3.25	White Paper	3.25
4075-4.25	White Paper	4.25
4075-5.25	White Paper	5.25
4075-6.5	White Paper	6.5
4075-8.5	White Paper	8.5
4075-10.5	White Paper	10.5
4075-12	White Paper	12.0
4075-14	White Paper	14.0
4075-14.5	White Paper	14.5
4075-15	White Paper	15.0
4075-16	White Paper	16.0
4075-18	White Paper	18.0
4075-20	White Paper	20.0
4075-24	White Paper	24.0
4075-30	White Paper	30.0
4075-36	White Paper	36.0
4075-48	White Paper	48.0

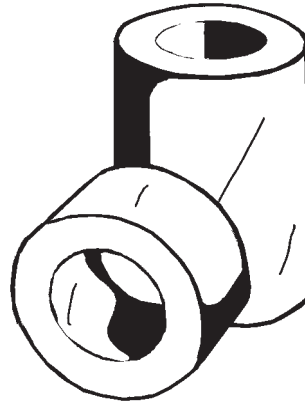

"R" CONFORM APPLICATION TAPE

Conform series application tape has an advanced release liner adhesion (RLA) technology designed with superior lay flat and conformability to resist tunneling, wrinkling and edge curling on rolled or stacked cut and printed vinyl graphics. Sold by the 100 yard roll.

Catalog Number	Description	Width (Inches)
4075RLA-1.25	White Paper	1.25
4075RLA-2.25	White Paper	2.25
4075RLA-3.25	White Paper	3.25
4075RLA-4.25	White Paper	4.25
4075RLA-5.25	White Paper	5.25
4075RLA-6.5	White Paper	6.5
4075RLA-8.5	White Paper	8.5
4075RLA-10.5	White Paper	10.5
4075RLA-12	White Paper	12.0
4075RLA-14	White Paper	14.0
4075RLA-15	White Paper	15.0
4075RLA-16	White Paper	16.0
4075RLA-18	White Paper	18.0
4075RLA-20	White Paper	20.0
4075RLA-24	White Paper	24.0
4075RLA-30	White Paper	30.0
4075RLA-36	White Paper	36.0
4075RLA-48	White Paper	48.0
4075RLA-60	White Paper	60.0

CLEAR CHOICE APPLICATION TAPE

AT-60 Clear Choice application tape is high quality, economical and it's exceptional clarity facilitates precise registration of graphics. A "Quick-Stick" adhesive system provides the necessary power to transfer stubborn vinyl graphics while it's rigid facestock provides excellent layflat to resist curling. Additional features include; non-stretching facestock, which minimizes misalignment problems, easily pulls apart without adhesive delamination if the adhesive side comes in contact with itself, easily unwinds and adhesive will not build or yellow over time. Sold by the 100 yard roll.

Catalog Number	Description	Width (Inches)
AT60-1.25	Clear	1.25
AT60-2.25	Clear	2.25
AT60-3.25	Clear	3.25
AT60-4.25	Clear	4.25
AT60-5.25	Clear	5.25
AT60-6.5	Clear	6.5
AT60-8.5	Clear	8.5
AT60-10.5	Clear	10.5
AT60-12	Clear	12.0
AT60-13	Clear	13.0
AT60-14	Clear	14.0
AT60-15	Clear	15.0
AT60-16	Clear	16.0
AT60-18	Clear	18.0
AT60-20	Clear	20.0
AT60-24	Clear	24.0
AT60-30	Clear	30.0
AT60-36	Clear	36.0
AT60-48	Clear	48.0

E-Z TEAR APPLICATION TAPE

AT42 series E-Z Tear application tape is a transparent, heavy guage, embossed, non-static polyethylene film with a medium-tack natural rubber adhesive. It is exceptionally easy to snap and tear. Handles like paper. Does not wrinkle or stretch. Its matte, non-glare surface enables perfect registration. Controlled adhesion sticks only when pressure is applied, with no build up of tack level. Sold by the 100 yard roll.

Catalog Number	Description	Width (Inches)
AT42RLA-1.25	Matte Clear	1.25
AT42RLA-2.25	Matte Clear	2.25
AT42RLA-3.25	Matte Clear	3.25
AT42RLA-4.25	Matte Clear	4.25
AT42RLA-5.25	Matte Clear	5.25
AT42RLA-6.5	Matte Clear	6.5
AT42RLA-8.5	Matte Clear	8.5
AT42RLA-10.5	Matte Clear	10.5
AT42RLA-12	Matte Clear	12.0
AT42RLA-14	Matte Clear	14.0
AT42RLA-15	Matte Clear	15.0
AT42RLA-16	Matte Clear	16.0
AT42RLA-18	Matte Clear	18.0
AT42RLA-20	Matte Clear	20.0
AT42RLA-24	Matte Clear	24.0
AT42RLA-30	Matte Clear	30.0
AT42RLA-36	Matte Clear	36.0
AT42RLA-48	Matte Clear	48.0

PREMIUM TAPES AND FILMS

Many other high performance tapes and films also available.

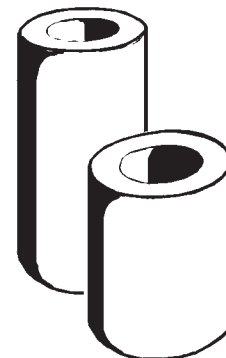



TRANSFER-RITE APPLICATION TAPE

Transfer-Rite application tape has the proper adhesive tack to lift and transfer intricate graphics from vinyl film. 4.2 mil tape is available in 100 yard rolls.

Catalog Number	Width (Inches)
592U-1.25	1.25
592U-2.25	2.25
592U-2.5	2.5
592U-3.25	3.25
592U-4.25	4.25
592U-4.5	4.5
592U-5.5	5.5
592U-6	6.0
592U-6.5	6.5
592U-7	7.0
592U-8	8.0
592U-9	9.0
592U-10.5	10.5
592U-12	12.0
592U-12.5	12.5
592U-14	14.0
592U-14.5	14.5
592U-16	16.0
592U-18	18.0
592U-20	20.0
592U-24	24.0
592U-30	30.0
592U-33.5	33.5
592U-36	36.0
592U-48	48.0

GERBER APPLICATION TAPE

Standard tack application tape has a special tack adhesive to lift and transfer most graphics from vinyl film. High tack tape is useful when working with small copy. Clear application tape has grid lines that are useful when aligning copy with existing reference. Available in 100 yard rolls.

Catalog Number	Description	Width (Inches)
P26517A	High Tack	.625
P26518A	High Tack	1.25
P26519A	High Tack	2.25
P27961A	High Tack	3.25
P27962A	High Tack	4.25
P27963A	High Tack	6.5
P27964A	High Tack	8.5
P27965A	High Tack	10.5
P27966A	High Tack	12.5
P26520A	Standard Tack	3.25
P26521A	Standard Tack	4.25
P26523A	Standard Tack	6.5
P26524A	Standard Tack	8.5
P26525A	Standard Tack	10.5
P26526A	Standard Tack	12.5
P37099A	Clear with Grid	1.25
P26685A	Clear with Grid	2.25
P26686A	Clear with Grid	3.25
P26687A	Clear with Grid	4.25
P26688A	Clear with Grid	6.5
P26689A	Clear with Grid	8.5
P26690A	Clear with Grid	10.5

3M APPLICATION TAPE

Series SCMPM3 tape is for general premasking, prespacing and application. Series SCPM44 is for preprinted or large graphics. Series SCPS2 is also for prespacing and application. Tape is sold in 100 yard rolls. 250 yard rolls also available.

Catalog Number	Width Inches	Length (Yards)
MMM-SCPM3-24	24"	100
MMM-SCPM3-36	36"	100
MMM-SCPM3-48	48"	100
MMM-SCPM4424	24"	100
MMM-SCPM4436	36"	100
MMM-SCPM4448	48"	100
MMM-SCPS2-24	24"	100
MMM-SCPS2-36	36"	100
MMM-SCPS2-48	48"	100

3M Application Tape Recommendations

Product	Application	Pre-spaced
Unprinted 3M Scotchlac Film 3M Controltac Film 3M ScotchLite Sheeting	SCPM - 3	SCPM - 3 or SCPS - 2
7725SE Dusted Crystal and Fluorescent Frosted Crystal	SCPM - 3 SCPS - 2	SCPS - 2 SCPS - 53X





3M THERMAL INK JET • TIJ

Wide Format Media

WEATHERABLE TIJ MEDIA

Two weatherable products are available from 3M™; an opaque media for posters and signs and a translucent media for backlit graphics. Three overlaminates that provide additional UV and physical protection are also available. Overlaminates give graphics a lustre, matte or high-gloss finish and have a pressure sensitive clear adhesive for hot or cold lamination. Both medias can be used on flat or curved applications requiring up to 18 months weatherability outdoors, five years indoors. Graphics made by 3M™ TIJ Graphics Certified Fabricators using 3M™ components are both UV stable and water-fast. These graphics are covered by the 3M™ MCS™ (Matched Component System) warranty for a period of 1 year for exterior applications and 5 years for interior applications. Media can be stored up to one year without deterioration. For best performance store media in the original packaging in a relative humidity of 20% to 80% and a temperature of 40° to 80° F (4-27° C). A wide range of additional TIJ media also available.

Catalog Number	Description	Thickness	Roll Width	Roll Length (Yards)
3637-20-3610	Translucent Imaging Media, Cast Vinyl	2mil	36"	10
3637-20-3625	Translucent Imaging Media, Cast Vinyl	2mil	36"	25
3637-20-4910	Translucent Imaging Media, Cast Vinyl	2mil	49"	10
3637-20-4925	Translucent Imaging Media, Cast Vinyl	2mil	49"	25
3657-10-4910	Opaque Imaging Media, Cast Vinyl	2mil	49"	10
3657-10-4925	Opaque Imaging Media, Cast Vinyl	2mil	49"	25
8522CP-3615	Opaque Imaging Media	7mil	36"	15
8522CP-5415	Opaque Imaging Media	7mil	54"	15
8519CP-3625	Lustre Overlamine	2mil	36"	25
8519CP-5425	Lustre Overlamine	2mil	54"	25
8520CP-5425	Matte Overlamine	2mil	54"	25

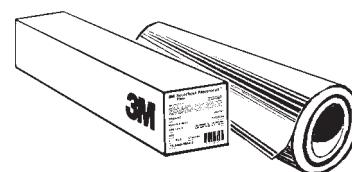

SHORT TERM TIJ MEDIA

For indoor flat or curved applications. Media provides handling durability and gloss level control. Can be hot or cold laminated. A wide range of additional TIJ media also available.

Catalog Number	Description	For Plotters ⁽¹⁾	Thickness Inches	Roll Width	Roll Length (Yards)
8501-3625	Clear Imaging Media, Polyester	N2, N3, LM, SG, HP, EP, HP750C/HP755C	4mil	36"	25
8501H-3625	Clear Imaging Media, Polyester		4mil	36"	25
8501CP-3610	Clear Imaging Media	HP2000, HP2500, HP3000, HP3500	4mil	36"	10
8501CP-3625	Clear Imaging Media		4mil	36"	25
8501CP-4910	Clear Imaging Media		4mil	49"	10
8501CP-4925	Clear Imaging Media		4mil	49"	25
8504CP-3620	Changeable Opaque Imaging Media	HP3000, HP3500	4mil	36"	20
8504CP-5420	Changeable Opaque Imaging Media		4mil	54"	20
8510-3625	Lustre Protective Finish, Vinyl Overlamine w/PSA	-	2mil	36"	25
8511-3625	Matte Protective Finish, Vinyl Overlamine w/PSA	-	2mil	36"	25
8512-3625	Hi-Gloss Protective Finish, Polyester Overlamine w/PSA	-	2mil	36"	25
8572-3625	Translucent Backing		2mil	36"	25
8572-4925	Translucent Backing		2mil	49"	25
8560-3525	Clear Application Adhesive		-	35"	25

NOTE: ⁽¹⁾ Consult manufacturer's information before using.



AZON COLOR MEDIA

AzonColor® Inkjet Media is designed for use in inkjet printers. Available in a wide variety of widths and types. AzonColor® Media is suitable for use in display graphics, signs, trade show graphics, banners, murals, point-of-purchase and backlit signage. Other uses include posters, framed art, overlays and wall hangings. The following pages represent many of the Azon products most commonly used and stocked. Most products are an ideal match with most printers. Some product series numbers are followed by an "HP" or "N" suffix. In most cases an "HP" suffix notes the product is an ideal match for Hewlett Packard printers and a few others. In most cases, an "N" suffix notes the product is an ideal match for Encad printers and a few others. Items that do not have a suffix after the series number are an ideal match or are recommended for CAD line-work and/or light ink coverage for most all printers. Consult the Azon compatibility chart in the Azon catalog prior to use. Other widths and types also available.

POWER PAPER • 735

The combination of a water-resistant inkjet coating along with the high quality of this specially formulated wet strength base paper provides a broad range of applications. Perfect for outdoor posters and a great product for uses that require added handling characteristics.

Catalog Number	Description	Width	Length (Feet)
AZ-735-36100	Power Paper	36"	100
AZ-735-50100	Power Paper	50"	100
AZ-735-54100	Power Paper	54"	100

POWER PAPER FAUX ARTIST CANVAS • 736

The combination of a proprietary water-resistant inkjet coating along with the high quality of this specially formulated wet strength base paper provides for a broad range of applications and uses. Perfect for faux fine art.

Catalog Number	Description	Width	Length (Feet)
AZ-736-3660	Power Paper Faux Artist Canvas	36"	60
AZ-736-5060	Power Paper Faux Artist Canvas	50"	60
AZ-736-5460	Power Paper Faux Artist Canvas	54"	60

POWER PAPER ADHESIVE BACK • 737

Power Paper Series 735 combined with a permanent adhesive coating. This great product could prove to be the most important item in the Azon product line as its uses are endless.

Catalog Number	Description	Width	Length (Feet)
AZ-737-3660	Power Paper Adhesive Back	36"	60
AZ-737-4260	Power Paper Adhesive Back	42"	60
AZ-737-5060	Power Paper Adhesive Back	50"	60
AZ-737-5460	Power Paper Adhesive Back	54"	60

ADVANTAGE COLOR PAPER • 717

A water resistant, color paper that offers exceptional image resolution. Its bright white base is perfect for economical, everyday color printing. Its special backcoat makes for a flatter sheet and its 24lb. base is ideally suited for all types of graphic and CAD applications.

PREMIUM COLOR PAPER • 747

This specially formulated bond is perfect for applications that require extremely high resolutions. Its low dot gain allows for a broader color spectrum and produces crisper, cleaner finished prints. Its 27lb. weight reduces bleed through or cockling and prevents head crashing, normally associated with heavy ink lay down.

ECONOMICAL HEAVY WEIGHT PAPER • 749

A lighter weight version of 746 except coated on one side. Weighs in at 36lb. and offers an economical choice for wide format color printing.

HEAVY WEIGHT PREMIUM 2 SIDED PAPER • 746

Because both sides are printable, this premium coated paper is perfect for proofing applications. Its coating provides brilliant, crisp images and the heavy weight of the product eliminates show-through. Even when two-sided printing is not the requirement, this double-coated paper will provide a durable output capable of handling volume ink saturation.

CLEAR FILM • 787N

A 4mil clear film with an opaque, white paper interleaved to ensure printer recognition. Designed for all types of multi-layered imaging, signage and overlays. Interleaf also reduces registration problems and slippage.

ALTERNATIVE PHOTO BASE • SATIN • 755N

Alternative Photo Base (APB) produces the same high-quality look of glossy or matte photo base after lamination at a more economical and affordable price. Another benefit is that the waiting time to take the image to a laminator is eliminated. APB needs only minutes to dry, not hours and it's ready to laminate.

Catalog Number	Description	Width	Length (Feet)
AZ-755N36100	Alternative Photo Base Paper, Satin	36"	100
AZ-755N54100	Alternative Photo Base Paper, Satin	54"	100



AZON COLOR MEDIA cont.

SEMI-MATTE PHOTOGRAPHIC • 756N

Semi-Matte Photographic Paper produces deep, rich colors of incredible density. The semi-matte surface offers an expanded viewing angle without the reflections and glare found with a glossy surface.

Catalog Number	Description	Width	Length (Feet)
AZ-756N24100	Photographic Paper, Semi-Matte	24"	100
AZ-756N36100	Photographic Paper, Semi-Matte	36"	100
AZ-756N50100	Photographic Paper, Semi-Matte	50"	100
AZ-756N54100	Photographic Paper, Semi-Matte	54"	100
AZ-756N60100	Photographic Paper, Semi-Matte	60"	100

GLOSSY PHOTOGRAPHIC • 758N

Glossy Photographic is perfect for presentations and graphic applications. Inks that are applied take on a glossy sheen that makes them leap off the paper.

Catalog Number	Description	Width	Length (Feet)
AZ-758N36100	Glossy Photographic Paper	36"	100
AZ-758N54100	Glossy Photographic Paper	54"	100

DISPLAY GRAPHICS FILM • 766HP & 766N

AZONcolor 10 mil Polycarbonate Film eliminates a step and saves time and money in the process. For large display graphics, most output vendors overlamine graphic output with heavyweight, scuff-resistant polycarbonate film for protection and glare reduction. With this film, graphics can be printed in reverse, then turned over for mounting without overlamination. Applications for such a versatile and durable product are endless. Recommended for use with dye-based inks only.

Catalog Number	Description	Width	Length (Feet)
AZ-766HP3660	Display Graphics Film	36"	60
AZ-766HP5460	Display Graphics Film	54"	60
AZ-766N3660	Display Graphics Film	36"	60
AZ-766N5060	Display Graphics Film	50"	60

ADHESIVE BACKED VINYL • 770N

Adhesive Backed Vinyl adds design flexibility to inkjet media. It has the same look and superior imaging quality found in AZON's Glossy Photographic Paper Series 750N, with an adhesive backing that allows for many mounting options. Adhesive Backed Vinyl is normally used for indoor applications. For outdoor applications it is recommended that this product be overlaminated for protection against abrasion, moisture and image fade from UV light exposure.

Catalog Number	Description	Width	Length (Feet)
AZ-770N2460	Adhesive Backed Vinyl	24"	60
AZ-770N3660	Adhesive Backed Vinyl	36"	60
AZ-770N5060	Adhesive Backed Vinyl	50"	60
AZ-770N5460	Adhesive Backed Vinyl	54"	60

VIEW THRU FILM • 777N

AZONcolor View Thru Film is among the most popular products for inkjet output today. This patented semi-opaque film is designed specifically for backlit applications and offers extremely high color fidelity with all types of backlit fixtures. Because this film is semi-matte, there is no need to add a diffuser between the output and light source. The new "instant dry" coating allows immediate handling of the print. Recommended for use with dye-based inks only. Also available in HP version. Consult compatibility chart in Azon catalog.

Catalog Number	Description	Width	Length (Feet)
AZ-777N36100	View Thru Film	36"	100
AZ-777N50100	View Thru Film	50"	100
AZ-777N54100	View Thru Film	54"	100

WHITE OPAQUE FILM • 797N

AZONcolor White Opaque Film is an extremely durable, glossy, high-resolution, color inkjet film offering superb brilliance. Reverse side show-through is totally eliminated because this film does not break down during heavy ink application. An ideal product for presentation imaging as well as large format display/poster printing.

Catalog Number	Description	Width	Length (Feet)
AZ-797N36100	Opaque Film	36"	100
AZ-797N42100	Opaque Film	42"	100
AZ-797N50100	Opaque Film	50"	100



AZON OUTDOOR MEDIA

POLYETHYLENE BANNER • 810

AZONcolor Polyethylene Banner material is durable and water resistant. An ultra smooth surface provides excellent imaging results. Pigmented inks are recommended for outdoor applications, however, dye-based inks may be used for indoor applications.

Catalog Number	Description	Width	Length (Feet)
AZ-810-3650	Banner Material	36"	50
AZ-810-5350	Banner Material	53"	50

MATTE ADHESIVE-BACKED VINYL • 850

This adhesive-backed matte vinyl material has a water-resistant coating that allows for vibrant, beautiful imaging with a matte surface which allows for a wide viewing angle. It has a repositionable adhesive layer for flexibility and multiple use applications.

Catalog Number	Description	Width	Length (Feet)
AZ-850-3640	Adhesive-Backed Vinyl, Matte	36"	40
AZ-850-4240	Adhesive-Backed Vinyl, Matte	42"	40
AZ-850-5040	Adhesive-Backed Vinyl, Matte	50"	40
AZ-850-5440	Adhesive-Backed Vinyl, Matte	54"	40
AZ-850-6040	Adhesive-Backed Vinyl, Matte	60"	40

SCRIM VINYL • 820

Premium Scrim Vinyl material provides a great deal of opacity for banner applications. Its opacity minimizes show-through from sunlight and other factors. Reinforced layer provides excellent durability for both indoor and outdoor applications and the inkjet coating allows for high-end, water-resistant imaging.

Catalog Number	Description	Width	Length (Feet)
AZ-820-2440	Scrim Vinyl	24"	40
AZ-820-3640	Scrim Vinyl	36"	40
AZ-820-5040	Scrim Vinyl	50"	40
AZ-820-6040	Scrim Vinyl	60"	40

REINFORCED POSTER PAPER • 830

Combining wet strength paper with nylon reinforcement, this paper becomes a very durable outdoor poster material. An economical alternative to high-end banner materials, especially for short-term indoor or outdoor use.

Catalog Number	Description	Width	Length (Feet)
AZ-830-3675	Reinforced Poster Paper	36"	75
AZ-830-5475	Reinforced Poster Paper	50"	75

TYVEK BANNER • 840

Tyvek Banner media is designed for both indoor and outdoor applications. The water resistant and tear resistant surface, combined with pigmented inks provides the fade resistance, longevity and durability needed for outdoor banner applications.

Catalog Number	Description	Width	Length (Feet)
AZ-840-3650	Tyvek Banner Material	36"	50
AZ-840-5450	Tyvek Banner Material	50"	50



HEWLETT PACKARD DESIGNJET PRINTER SUPPLIES

HP DESIGNJET PAPERS

Works with HP DesignJet CP Ink systems and HP DesignJet 2500CP/2000CP printers as a total printing solution for clear, sharp results. Excellent image quality on a wide variety of new HP DesignJet papers and film. HP coated paper for exceptional quality everyday prints. HP heavyweight coated papers for final presentations and displays. HP High-Gloss photo paper for high impact, photo-realistic images and graphics. HP semi-gloss paper for vivid, photo-realistic images and graphics. HP high-gloss white film for brilliant color, ultra-high gloss, extra fade-resistant images and graphics. All other Hewlett Packard imaging materials also available.

Catalog Number	Description	Roll Width	Roll Length
HEW-C6019A	Coated Paper	24"	150'
HEW-C6020A	Coated Paper	36"	150'
HEW-C6560B	Coated Paper	54"	150'
HEW-C6021A	Heavyweight Coated Paper	24"	100'
HEW-C6030C	Heavyweight Coated Paper	36"	100'
HEW-C6652B	Heavyweight Coated Paper	54"	100'
HEW-C6023A	Semi-Gloss Photo Paper	24"	100'
HEW-C6024A	Semi-Gloss Photo Paper	36"	100'
HEW-C6564A	Semi-Gloss Photo Paper	54"	100'
HEW-C6025A	High-Gloss Photo Paper	24"	100'
HEW-C6026A	High-Gloss Photo Paper	36"	100'
HEW-C6566A	High-Gloss Photo Paper	54"	100'
HEW-C1861A	Bright White 24lb.	36"	150'
HEW-C3885A	High-Gloss White	36"	70'

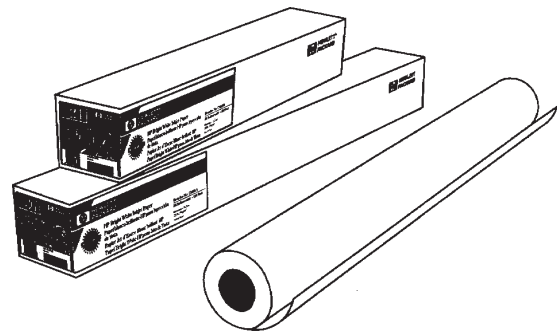

Graphics

HP DESIGNJET CP INK SYSTEMS

Water soluble and UV inks.

Catalog Number	Color
HEW-C1806A	Black
HEW-C1807A	Cyan
HEW-C1808A	Magenta
HEW-C1809A	Yellow
HEW-C1892A	Black (UV)
HEW-C1893A	Cyan (UV)
HEW-C1894A	Magenta (UV)
HEW-C1895A	Yellow (UV)
HEW-C4844A	Black (Series 500)
HEW-C4911A	Cyan (Series 500)
HEW-C4912A	Magenta (Series 500)
HEW-C4913A	Yellow (Series 500)



INTERSTATE ELECTRIC CO., INC.

2240 Yates Ave., Commerce, CA 90040 • 5435 Procyon, #100, Las Vegas, NV 89118 • 6860 Goodyear Rd., Benicia, CA 94510



HEWLETT PACKARD DESIGNJET GRAPHIC PRINTERS

Hewlett Packard has a full range of large format printers. Available in 36" or 54" widths, the HP 54" DesignJet 3000CP and 3500CP printers combine low operating cost, hassle-free use and outstanding image quality. A menu-driven control panel reduces training time and operator error. Built-in temperature and humidity sensors automatically adjust drying time so there is no need for constant supervision. Ink delivery system detects and bypasses clogged nozzles to ensure consistently reliable operation. HP DesignJet 2000CP (8 MB RAM) and 3000CP (12 MB RAM) printers require an external RIP or the supplied Microsoft Windows or AutoCAD drivers. HP DesignJet 2500CP (20 MB RAM) and 3500CP (36 MB RAM) come with built-in Adobe PostScript 3 RIP and ethernet connectivity. The HP 3000CP and 3500CP printers come standard with a take-up reel.

Produce photo-quality images with brilliant, accurate colors and smooth, subtle skin tones. HP DesignJet printers, ink systems and media are designed together for optimum image quality. Supports two ink sets; dye-based inks for photo-quality images and pigment-based UV inks for enhanced light-fastness with 3M MCS warranty. Auto-replenishment ink delivery system makes ink replacement clean and easy. Prints up to 400, 2' x 3' prints per dye-based ink system. Accepts a wide range of media including coated papers, glossy photo papers, vinyl and more. One year warranty with free on-site service and preventative maintenance if needed for high-volume users. Includes custom drivers for AutoCAD and Windows.

Many other Hewlett Packard printers and accessories also available.

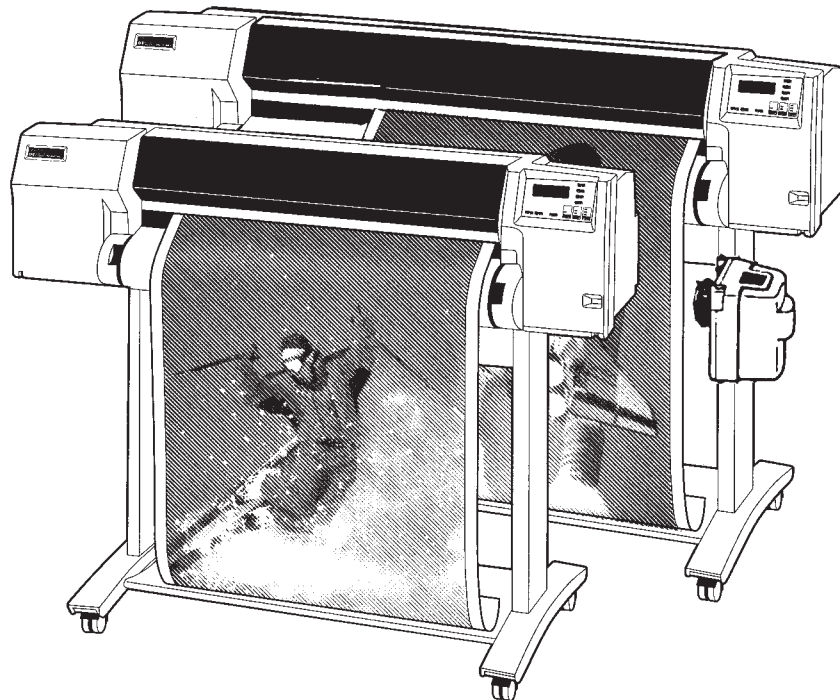

HARTCO SANDMASK STENCIL MATERIAL

Hartco Sandmask is a polyvinylchloride product. Resists sandblasting over applied areas on wood, glass, polyurethane foam, fiberglass and other similar substrates. HAR-135 is used primarily for hand cut operations. HAR-425 is used with plotters. Sold by the roll.

HARTCO

Catalog Number	Width	Roll Length	Thickness	Blade Angle	Perforated or Non-Perforated
HAR-135-S15	15"	10 Yards	35 mil	60°	Non-Perforated
HAR-135-S30	30"	10 Yards	35 mil	60°	Non-Perforated
HAR-310-S25	25"	20 Yards	10 mil	60°	Non-Perforated
HAR-310-S30	30"	20 Yards	10 mil	60°	Non-Perforated
HAR-S425-S15	15"	10 Yards	25 mil	60°	Non-Perforated
HAR-425-SP15	15"	10 Yards	25 mil	60°	Perforated
HAR-425-S25	25"	10 Yards	25 mil	60°	Non-Perforated
HAR-425-S30	30"	10 Yards	25 mil	60°	Non-Perforated

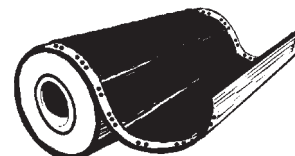
**ANCHOR SIGNBLAST STENCIL MATERIAL**

Anchor stencil products offer super tough blast resistance, clean precise reproductions of even the most intricate designs, cutting ease and is available in a variety of sizes to fit all plotters. Many other Anchor brand materials also available. Sold by the roll.

Style 111: A medium-tack stencil for use on preprinted or soft wood surfaces. Designed specifically for easy hand-cutting. White release liner is easily removed.

Style 116: A high-tack computer stencil for use on raw wood surfaces and urethane foamboard. Features trimmed edges and a strong, clear film liner that offers easy alignment and smooth, precise running on computerized signmaking machines. CAUTION: This stencil has a very aggressive adhesive and is not recommended for use on some woods without first testing a sample piece. Do not use on preprinted, pretreated or glass surfaces.

Style 117: Medium-tack version of style #116, specially designed for pretreated and preprinted surfaces. Excellent for soft woods without the risk of surface lift. Can also be used safely on glass, tile and pretreated urethane foamboard. Trimmed edges allow smooth, accurate tracking through computerized signmaking machines. A strong, clear film liner provides extra rigidity.

Style 125: A high-tack stencil designed for sandblasting on raw wood and urethane foamboard. Has easy-release orange liner. The strength of the adhesive eliminates the need for filler or spray adhesives. CAUTION: This stencil has a very aggressive adhesive and is not recommended for use on some woods without first testing a sample piece. Do not use on preprinted, pretreated or glass surfaces.

Style 157: Same construction as medium-tack #117 computer stencil, except that the hole pattern is for use on standard 1/2" center sprocket system machines. NOTE: style #157 will not work on large pin 30" plotters; style #117 is recommended for this use.

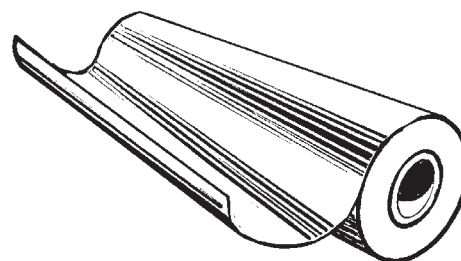
Intertape
ANCHOR

Catalog Number	Width	Roll Length	Tack	Perforated or Non-Perforated
ANC-111-2510	25"	10 Yards	Low	Non-Perforated
ANC-116-1510	15"	10 Yards	High	Non-Perforated
ANC-116-3010	30"	10 Yards	High	Non-Perforated
ANC-117-1510	15"	10 Yards	Medium	Non-Perforated
ANC-117-3010	30"	10 Yards	Medium	Non-Perforated
ANC-125-2510	25"	10 Yards	High	Non-Perforated
ANC-157-3010	30"	10 Yards	Medium	1/2" Perforated



GRAPHTEC CUTTING PRO SERIES HIGH PERFORMANCE CUTTER/PLOTTERS

Every Graphtec plotter is capable of cutting vinyl, adhesive film, reflective film, film for illuminated signs, rubyliths and sandblast rubber. In addition, Cutting Pro plotters are fully compatible with over 50 sign systems and software packages. High performance Cutting Pro series features 56ips top speed and intelligent tangential control with 500g of cutting force that suits the heaviest of sign production needs, yet offers smooth and precise cutting of the most detailed of graphics. With its user-friendly Accuload media alignment, multi-job-ready configuration for plot, cut and pounce operations, eight programmable user settings for instantaneous recall and setup, the FC5100 series is one of the most sophisticated and dependable sign making tools for the versatility required in todays diversified sign crafting environment.

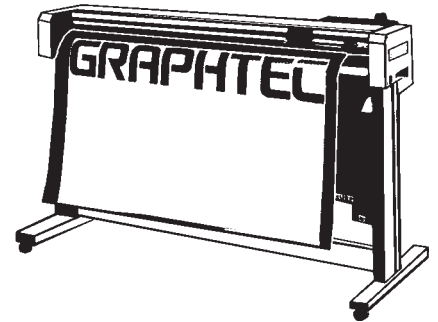

Catalog Number	Dimensions/ Movement	Dimensions W x D x H	Max. Cutting Width / Length	Material Width	Cutting Speed Axial / Diagonal
GRAFC510075	30" Friction Feed	44.7" x 19.1" x 13.8"	29.8" / 164'	6.3" to 36"	39.4ips / 55.7ips
GRAFC5100100	42" Friction Feed	56.7" x 26.8" x 46.3"	42" / 164'	6.3" to 48"	39.4ips / 55.7ips
GRAFC5100130	54" Friction Feed	66.9" x 26.8" x 46.3"	54" / 164'	6.3" to 59"	39.4ips / 55.7ips

GRAPHTEC CUTTING PRO SUPPLIES & ACCESSORIES

Catalog Number	Description	Put Up
GRA-CB09UA-5	Blade, Supersteel, .9mm, All Purpose	1/5
GRA-CB15U-5	Blade, Supersteel, 1.5mm, for Thick Material	Pkg. 5
GRACB15UAK30	Blade, Supersteel, 1.5mm, for Sandblast & Reflective Stencil	1/5
GRAPHP32CB09	Holder for .9mm Blade	1
GRAPHP32CB15	Holder for 1.5mm Blade	1
PHP32-CB15N1	Holder for Sandblast & Reflective Stencil 1.5mm Blade	1
GRA-KF552BK	Black Fiber Tip Pen, Disposable Water-Based	1/5
GRA-KF552RD	Red Fiber Tip Pen, Disposable Water-Based	1/5
GRA-KF562BK	Black Fiber Tip Pen, Disposable Solvent-Based	1/5
GRA-KB542BK	Black Roller-Ball Pen, 3mm Wide, Water Based Ink	1/5
GRA58000017T	Stand for 30" GRAFC5100-75 Plotter	1
GRA58000018T	Media catch basket for 30" GRAFC5100-75 Plotter	1
GRA58000019T	Media catch basket for 42" GRAFC5100-100 Plotter	1
GRA58000020T	Media catch basket for 54" GRAFC5100-130 Plotter	1

GRAPHTEC CE2000 SERIES CUTTER/ PLOTTER

The CE2000 is an entry level low cost cutter/plotter that retains many of the features that make the FC Cutting Pro series so popular: Interactive LCD panel for intuitive operation, copy function for repeat jobs, 2 MB buffer, precision media supply system and an optional floor stand. Its advanced digital servo drive system engineered with Graphtec's technology provides the same level of cutting quality as the company's high-end FC Cutting Pro series plotter. Cutting speed remains a fast 24" per second for the CE2000-60 and 40" per second for the CE2000-120.

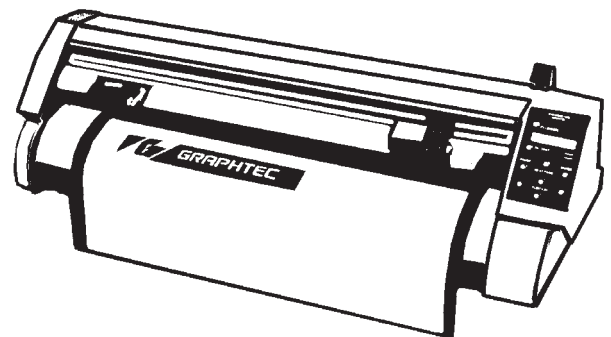

Catalog Number	Description
GRA-CE200060	Max. Cutting Area 23.0" x 164', Cutting Speed 24ips
GRACE2000120	Max. Cutting Area 48" x 164', Cutting Speed 40ips
GRA-CE2K60FS	Floor Stand for 24" CE2000-60 Plotter



GRAPHTEC SIGNJET PRO SERIES COMBINATION PRINTER/CUTTER/PLOTTERS

By adapting wide-format inkjet technology to Graphtec cutting plotters, SignJet Pro prints photo-realistic images onto a variety of media allowing on-demand contour cutting of the printed design. SignJet Pro also functions as a professional cutting plotter at speeds and reliability comparable to Graphtec's Cutting Pro series. Graphtec's SignJet Pro is extremely versatile and capable of printing with UV-resistant inks to create vibrant outdoor signage with color that lasts.

SignJet Pro is available in 42" and 60" widths and features Graphtec's proprietary dual-head configuration that enables fast 600dpi resolution printing via 512 nozzles per color. In addition to inkjet imaging vinyl, SignJet Pro can print on photo gloss, semi-gloss, clear or ultra white film, specialty or premium matte, backlit display film, canvas and self adhesive vinyl. SignJet Pro is compatible with Raster/Print Mode- HP-RTL and Vector/Cutting Mode-HP-GL and GP-GL command formats.

Catalog Number	Dimensions W x D x H	Max. Loadable Film Width	Max. Printing Cutting Area ⁽¹⁾	Cutting Speed	Stand
GRA-JX2150	106" x 29" x 55"	60"	(Cutting) 60" x 165' (Printing) 60" x 99'	Axial: 36ips	Included
GRA-JX2100	89" x 29" x 55"	42"	(Cutting) 42" x 165' (Printing) 42" x 99'	Axial: 36ips	Included

NOTE: ⁽¹⁾ Expand Mode.

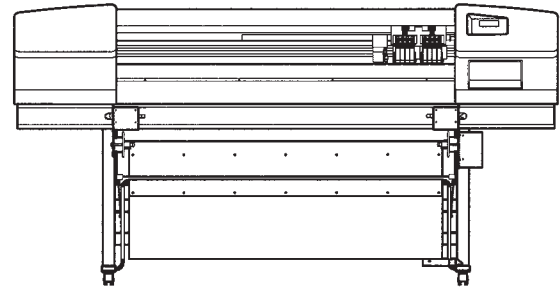

GRAPHTEC SIGNJET STARTER SUPPLY KITS

Catalog Number	Description
GRA-JX2ST-1	UV Ink System CMYK Set
GRA-JX2ST-2	Dye Ink System CMYK Set
GRA-JX2ST-3	UV Ink CMYK Set & 1 Roll of 42" x 50' DuraVinyl Matte Vinyl
GRA-JX2ST-4	UV Ink CMYK Set & 1 Roll of 36" x 40' Water Resistant Matte Vinyl
GRA-JX2ST-5	Dye Ink CMYK Set & 1 Roll of 42" x 100' Premium Photo Gloss Paper
GRA-JX2ST-6	Dye Ink CMYK Set & 1 Roll of 42" x 100' Premium Photo Satin Paper

GRAPHTEC SIGNJET ACCESSORIES

Catalog Number	Description
GRA-RSK0003	Stand-mounted Roll Media Supply System for Vinyl Cutting for the GRA-JX2150
GRA-RSK0004	Stand-mounted Roll Media Supply System for Vinyl Cutting for the GRA-JX2100
GRA-PG0008	Front and Rear Media Catch Basket for the GRA-JX2150 ⁽¹⁾
GRA-PG0009	Front and Rear Media Catch Basket for the GRA-JX2100 ⁽¹⁾
GRA-TU0001	Replacement Tubing System for Quick Ink Type Switch-over (8 lines per system) for the GRA-JX2150
GRA-TU0002	Replacement Tubing System for Quick Ink Type Switch-over (8 lines per system) for the GRA-JX2100

NOTE: ⁽¹⁾ Media basket can only be used when the GRA-RSK0003 or GRA-RSK0004 roll stocker has been mounted.



FLEXI 7 SOFTWARE



The Flexi Family 7 consists of five products which cater to specific user levels and production goals. Scanvec Amiable offers benefits such as increasing user productivity, providing for quicker upgrades and language conversions and producing an easy-to-use, intuitive interface that will be comfortable for new and existing Flexi 7 users. All products in the Flexi Family 7 are available for Windows 95/98, Windows NT/2000/XP and Macintosh. Highlights of each software products are as follows:

FLEXISIGN-PRO • SCA-FLEX-PRO

FlexiSign-Pro is designed and engineered to be the total solution for any signmaking business. It features OLE, advanced bitmap filters and editing, RIPing tools, all special effects along with full vinyl cutting and color printing features including Adobe PostScript 3, ICC color profile support, Pantone® and vinyl color libraries. Includes direct drivers for popular inkjet, thermal transfer and print/cut devices, and vinyl cutters.

FLEXIEXPERT • SCA-FLXPRT

FlexiExpert is packaged for the professional signmaker who requires advanced vinyl cutting and bitmap editing tools, but does not need all the advanced color printing features. FlexiExpert features full design, scanning, and tracing functions, along with special effects, vinyl cutting and basic large-format color printing features. Also includes Job Estimator for accurate project management, design templates for faster production, direct drivers for popular inkjet, thermal color transfer and print/cut devices as well as drivers for vinyl cutters.

FLEXISIGN • SCA-FLXSIGN

FlexiSign, the signmaking software of choice offers all of the necessities for any sign business. Included in this complete design and cutting program are such features as import/export files, scanning and grayscale tracing, full text manipulation, vinyl libraries, multiple un-dos and re-dos, drag and drop color and stroke support. It also includes direct drivers for the industry's popular cutters and plotters.

FLEXILETTER • SCA-FLXLETTR

FlexiLetter is an entry-level design and cutting software that features import/export of files, full text manipulation, and direct drivers for the industry's most popular vinyl cutters.

FLEXIDESIGNER • SCA-FLXDSGNR

FlexiDesigner is a pure software design program that is used in a second design-only or sales station in which layouts can be shown to customers without tying up the production line. It has all of the advanced design, layout and image editing features of FlexiSign-Pro to prepare files for output on another FlexiSign-Pro station.

PARALLEL INTERFACE ADAPTER • SCA-PIACABLE

For Macintosh serial to parallel port connection.



MATSER DESIGNS BY BERGEN



MASTER DESIGNS SIGN LAYOUT COLLECTION • SCA-MD-SLC

The Master Designs by Bergen Sign Layout Collection contains sixty-four sample designs with many changeable layouts to choose from. This collection includes a dynamic array of eleven color backgrounds with twenty-seven different color combinations in each. Can be used to easily produce designs by changing the layout, text, fonts, size, shape or distortion with choice of color background. Additional features and capabilities include custom gradient fills and advanced color samples.

MASTER DESIGNS CUSTOM FILLS COLLECTION • SCA-MD-CFC

The Master Designs by Bergen Custom Fills Collection is used to add texture fills such as Diamond Plate, Gold Diamond Plate, Carbon Fiber and Custom Flame to text or graphics. Also includes examples of eight different custom flames and ten color layouts. Additionally, it is designed to use CMYK inks and foils, eliminating the need to use special materials or proofing to premium media.

MASTER DESIGNS METAL MANIA COLLECTION • SCA-MD-MMC

The Master Designs by Bergen Metal Mania Collection allows the addition of custom metal fills into any text or graphic. Metal Mania has forty-two custom fills that include realistic Gold Leaf, Engine Turn, Brushed Cylinder and Plated. Every metal effect can be given an extra boost by choosing a variety of colors such as gold, bronze, blue, green, purple, silver, orange and red. Designed to use CMYK inks and foils therefore special materials are not needed and a desktop printer can be used for proofing.



PHOTOPRINT 3



Scanvec Amiable PhotoPrint 3 is a family of professional digital printing and RIP software that offers versatility, productivity and quality output to meet diverse industry requirements. PhotoPrint 3 includes all of the latest technologies such as certified Adobe PostScript 3, ICC technology and direct drivers for all major output devices.

PHOTOPRINT SE • SCA-PP-SE

PhotoPrint SE is an entry-level single printer and single workstation RIP package for the Mac and PC platform. PhotoPrint SE works seamlessly through popular design software such as Adobe Photoshop, Illustrator, QuarkXpress, CorelDraw and all major CAD/AEC/GIS engineering solutions.

PHOTOPRINT DX • SCA-PP-DX

PhotoPrint DX includes all of the features of PhotoPRINT SE plus image editing and layout tools and the ability to produce output for contour cutting on a vinyl cutter.

PHOTOPRINT SERVER • SCA-PP-SRVR

PhotoPrint Server is a client-server RIP designed for networked and large production environments. PhotoPrint DX is included as the client software.

PHOTOPRINT SERVER-PRO • SCA-PP-SP

PhotoPrint Server-Pro has all of the features of PhotoPrint Server and includes the addition of PhotoPrint Editor. PhotoPrint Editor, which is only available with PhotoPrint Server-Pro, provides the added capabilities such as color calibration, auto serialization and templating.



WORKFLOW AND RIP SOFTWARE

Workflow and RIP software from Onyx takes the mystery out of color printing making it possible for graphics professionals to produce large format output from popular inkjet printers quickly and accurately the first time, every time.

ONYX RIPCENTER • OCE-ONYX-RC

Onyx RIPCenter is an economical, stand alone entry level software package that features ease of use and the ability to achieve professional color "out of the box". RIPCenter includes a PostScript RIP, Raster RIP, automatic tiling, job thumbnail and print nesting previews and support for one active printer with multiple "hot folders".

ONYX POSTERSHOP • OCE-ONYX-XT

Onyx PosterShop includes all of the features of RIPCenter with the addition of PreFlight and Media Manager. PreFlight features interactive sizing, cropping, custom tiling and pan and zoom. Media Manager is used to recalibrate the printer to print media as needed to meet changing print conditions. Media Manager also allows for the import and application of custom ICC profiles as well as creating and editing density calibration tables and controlling ink restrictions.

ONYX PRODUCTIONHOUSE • OCE-ONYX-PH

Onyx ProductionHouse includes all the features of PosterShop with the added ability to control three or more printers and Step & Repeater. Additionally, ProductionHouse software can concurrently execute two PostScript RIPs while sending output to multiple printers. Step & Repeater adds the ability to do seamless pattern tiling

ProductionHouse includes two PostScript RIPs, one raster RIP and support for four active printers with multiple "hot folders". Also included are media management, calibration, pre-flight preview, custom tiling and color correction, and Step & Repeater.

ONYX UPGRADES

Software upgrades from one level to another and from older versions are also available. Call for more information.

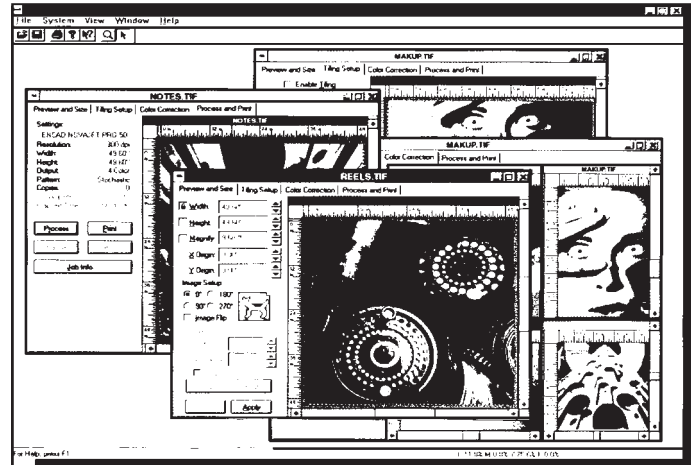

COMPUTER SYSTEMS

For Computer Aided Sign Making



A computer system can be configured for computerized sign making environments ranging from the smallest of shops to the most demanding design and production operations. We can also custom configure a system from our large selection of processors, memory, drives and monitors. Additionally we offer a number of system accessories such as scanners, modems, tape drives, sound cards, networking hardware and production hardware.



Graphics

Computer graphics systems can be customized to any specification or configured by recommendation.



PLOTTERS

All Gerber plotters are open architecture. Plotters will plot and cut text and graphics using many popular design software packages with HPGL drivers as well as with the Graphix Advantage systems.

All 15" sprocket-driven plotters are fully compatible with the Gerber Edge for cutting printed graphics.

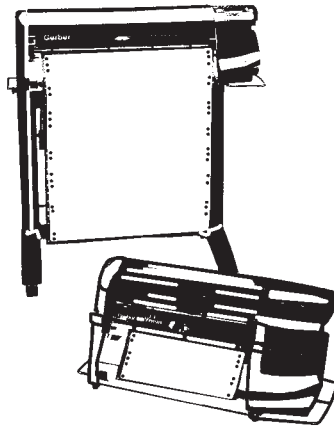

GSX PLUS PLOTTER

Stepper motor-driven, sprocket plotter that uses 15" (381mm) perforated materials. Plots and cuts text and graphics up to 13.25" (337mm) in height utilizing a swivel knife only. Includes an accessory kit, knife blade holder and blade, pen and material roll holder.

P55161A

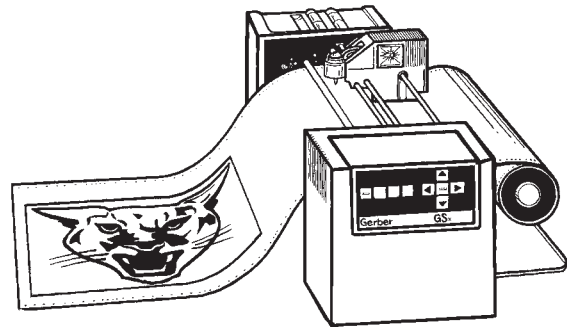

GERBER ENVISION 375 PLOTTER

Servo motor-driven, sprocket plotter that uses 15" (381mm) punched materials. Plots and cuts graphics up to 13.25" (337mm) in height at high speeds with a maximum of 36" per second on axis (50" per second on diagonal) and accelerations up to 3g's. Utilizes a swivel knife for optimal cutting of all Gerber materials and many others. Includes a knife tool holder and 45 degree blade, two additional 45° blades and 4 rollerball pens.

P66141A

GS15-PLUS PLOTTER

Stepper motor-driven, sprocket plotter that uses 15" (381mm) perforated materials. Plots and cuts text and graphics up to 13.25" (337mm) in height. Features "KMS" Knife Mode Switching™ technology which utilizes either a tangential-steered blade or a swivel knife for optimal cutting of all Gerber material and many others. Includes an accessory kit, knife blade holder and blade, pen, pounce wheel and material roll holder.

P55225A

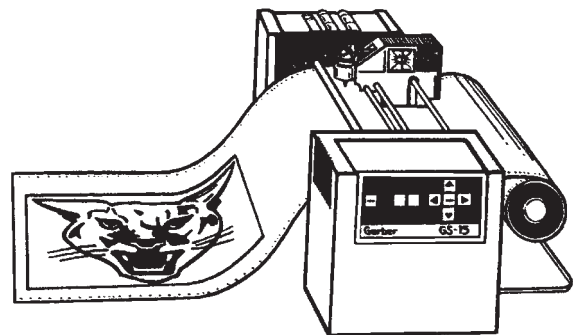

GERBER ENVISION 750 PLOTTER • P65509A

Servo motor-driven, sprocket plotter that uses 30" (762mm) punched materials. Plots and cuts graphics up to 27.25" (692mm) in height at high speeds with a maximum of 36" per second on axis (50" per second on diagonal) and accelerations up to 3g's. Utilizes a swivel knife for optimal cutting of all Gerber materials and many others. Includes an accessory kit, knife tool holder and 45° blade, two additional 45° blades, plotter stand and 4 rollerball pens.

P65509A

Graphics



PLOTTER ACCESSORIES

GS15^{Plus}, HS15^{Plus}, GS750^{Plus}, HS750^{Plus}, GS15, HS15, GS750, HS750, SPRINT IIB & SUPERSPRINT PLOTTERS

Ball Point Pen, Black	P32433A	Job Card, 100/Package	P38074B
Ball Point Pen, Blue	P32432A	Knife Holder w/30° SuperSharp Blade	P56734A
Ball Point Pen, Red	P32431A	Knife Holder w/30° SuperSharp Blade, Guarded	P26660B
Pen Holder w/Black Pen	P66925A	Material Roll Holder, 15"	P26381D
Pen Holder w/o Pen	P32434B	PC-to-Plotter Cable, 30 ft.	P61415C
Carbide Knife Blade, 30°	P17156B	PC-to-Plotter Cable, 50 ft.	P61414C
Carbide Knife Blade, 45°	P33489B	Pen Height Adjustment Tool	P28842B
Carbide Knife Blade, 60°	P37311B	Pounce Wheel Holder	P29508B
Fine Pounce Wheel, 11 Teeth 1/4" Diameter	P25032B	w/Fine Pitch Wheel, 11 Teeth, 1/4" Dia.	
Fuse, 3-Amp, 3AG, 250V GS15	P38643B	Squeegee	P23541C
Fuse, 5-Amp, 3AG, 250V HS15	P32356B	SuperSharp Carbide Knife Blade, 30°	P30033B
GS Drag Knife Assembly w/Shoe and Drag Knife Blade	P56518B	Tool Cap	P17189B
GS Drag Knife Blade	P44985B	Tool Inserts	P29506B
Hex Allen Wrench, .062"	P25934A	Tweezers	P25933A
HS Swivel Knife Assembly w/Shoe and 2 Blades	P56530B	Film Stripping Tool	P73983A
HS Swivel Knife Blade	P56928B	Rivet Brush Applicator	P42887A

S750, SIGNMAKER/750, GRAPHIX/750 & GSP SPRINT/750

Pen Holder w/Black Med. Pen	P67588A	Hex Allen Wrench, .062"	P25934A
Pen Holder w/o Pen	P19283B	Job Card, 100/Package	P38074B
Ball Point Pen, Fine, Black	P26177A	Knife Holder w/30° SuperSharp Blade	P26660B
Ball Point Pen, Med., Black	P25927A	Pen Height Adjustment Tool	P28842B
Ball Point Pen, Fine, Blue	P26180A	Pounce Wheel Holder	P25032B
Ball Point Pen, Fine, Red	P26178A	w/Fine Pitch Wheel, 11 Teeth, 1/4" Dia.	
Ball Point Pen, Med., Red	P25926A	Rivet Brush Applicator	P42887A
Carbide Knife Blade, 30°	P17156B	Squeegee	P23541C
Carbide Knife Blade, 45°	P33489B	SuperSharp Carbide Knife Blade, 30°	P30033B
Carbide Knife Blade, 60°	P37311B	Theta Knife Lift Washer	P27081B
Felt Tip Pen Holder w/Blue Med. Ball Point Pen	P17939B	Tool Cap	P17189B
Felt Tip Pen Holder w/o Boldliner Pen	P21730B	Tool Weight #1	P17486B
Felt Tip Boldliner Pen, Black	P26174A	Tool Weight #2	P17487B
Felt Tip Boldliner Pen, Blue	P26179A	Tool Weight #3	P17179B
Felt Tip Boldliner Pen, Red	P51918A	Tool Weight #4	P17609B
Fine Pounce Wheel, 11 Teeth 1/4" Diameter	P25032B	Tool Weight #5	P17610B
Fuse, 2 Amp, 3AG, 250V	P26176A	Tweezers	P25933A
		Film Stripping Tool	P73983A

GSxPLUS & GSx PLOTTERS

Ball Point Pen, Black	P32433A	Job Card, 100/Package	P38074B
Ball Point Pen, Blue	P32432A	Material Roll Holder, 15"	P26381D
Ball Point Pen, Red	P32431A	Pen Height Adjustment Tool	P28842B
Pen Holder w/Black Pen	P66925A	Rivet Brush Applicator	P42887A
Pen Holder w/o Pen	P32434B	Squeegee	P23541C
Fuse, 3 Amp, 3AG, 250V	P38643B	Tool Cap	P17189B
GS Drag Knife w/Shoe and 2 Blades	P56518B	Tool Inserts	P29506B
GS Drag Knife Assembly	P44985B	Tweezers	P25933A
Hex Allen Wrench, .062"	P25934A	Film Stripping Tool	P73983A

SPRINT & SIGNMAKER IVB

Pen Holder w/Black Med. Pen	P66925A	Fine Pounce Wheel, 11 Teeth 1/4" Diameter	P25032B
Pen Holder w/o Pen	P32434A	Fuse, 4 Amp, 3AG, 250V	P26704A
Ball Point Pen, Fine, Black	P26177A	Hex Allen Wrench, .062"	P25934A
Ball Point Pen, Med., Black	P25927A	Knife Holder w/30° SuperSharp Blade	P56734A
Ball Point Pen, Fine, Blue	P26180A	Knife Holder w/30° SuperSharp Blade, Guarded	P26660B
Ball Point Pen, Med., Blue	P25439A	Pen Height Adjustment Tool	P28842B
Ball Point Pen, Fine, Red	P26178A	Pounce Wheel Holder	P29508B
Ball Point Pen, Med., Red	P25926A	w/Fine Pitch Wheel, 11 Teeth, 1/4" Dia.	
Carbide Knife Blade, 30°	P17156B	Rivet Brush Applicator	P42887A
Carbide Knife Blade, 45°	P33489B	Squeegee	P23541C
Carbide Knife Blade, 60°	P37311B	SuperSharp Carbide Knife Blade, 30°	P30033B
Felt Tip Pen Holder w/Blue Boldliner Pen	P21734A	Tweezers	P25933A
Felt Tip Pen Holder w/o Boldliner Pen	P21730B	Film Stripping Tool	P73983B
Felt Tip Boldliner Pen, Black	P26174A	Tool Inserts, Black	P29506B
Felt Tip Boldliner Pen, Blue	P26179A		
Felt Tip Boldliner Pen, Red	P51918A		



FASTRACK 650 PLOTTER

Servo motor-driven, friction-feed plotter that uses perforated or non-perforated materials from 3.9" to 33.5" (99mm to 851 mm) wide when using a sheet. Utilizes swivel-knife technology to plot and cut text and graphics up to 24" (610mm) in height at high speed with a maximum of 39" per second on axis (55" per second on diagonal). Features pouncing capabilities, accurate alignment up to 32 feet, automatic material cut-off, key pad adjustable tool parameters and the ability to store parameters for each of the four tools for quick material change. Includes knife holder with 45° blade, two additional 45° knife blades, two felt tip pens, material roller support system, spare cutting pad and stand.

P70383A

FASTRACK 1300 PLOTTER

Servo motor-driven, friction-feed plotter that uses perforated or non-perforated materials from 3.9" to 52" (99mm to 1320mm) wide when using a roll and from 3.9" to 56" (99mm to 1420mm) wide when using a sheet. Utilizes swivel-knife technology to plot and cut text and graphics up to 48" (1200mm) in height at high speed with a maximum of 39" per second on axis (55" per second on diagonal). Features a third pinch wheel for positive material tracking, pouncing capabilities, accurate alignment up to 32 feet, automatic material cut-off, key pad adjustable tool parameters and the ability to store parameters for each of the four tools for quick material change. Includes knife holder with 45° blade, two additional 45° knife blades, two felt pens, material roller support system, spare cutting pad and stand.

P70386A

FASTRACK ACCESSORIES

Cutting Mat	P62751A	Felt Tip Pens, Red (5)	P59257A
Knife Blades, 30° (2)	P61638A	Rollerball Pens, Black (4)	P61643A
Knife Blades, 45° (2)	P61639A	Rollerball Pens, Blue (4)	P61644A
Knife Blades, 60° (2)	P61640A	Rollerball Pens, Red (4)	P61645A
Knife Holder w/o Depth	P61637A	Rollerball Pens, Green (4)	P61646A
Sheet-off Knife Blade Assy.	P63053A	Pouncing Mats (3)	P63054A
Felt Tip Pens, Black, (5)	P59259A	Pounce Assy., Complete	P61702A
Felt Tip Pens, Blue, (5)	P59258A	Pounce Tool Pin	P59184A

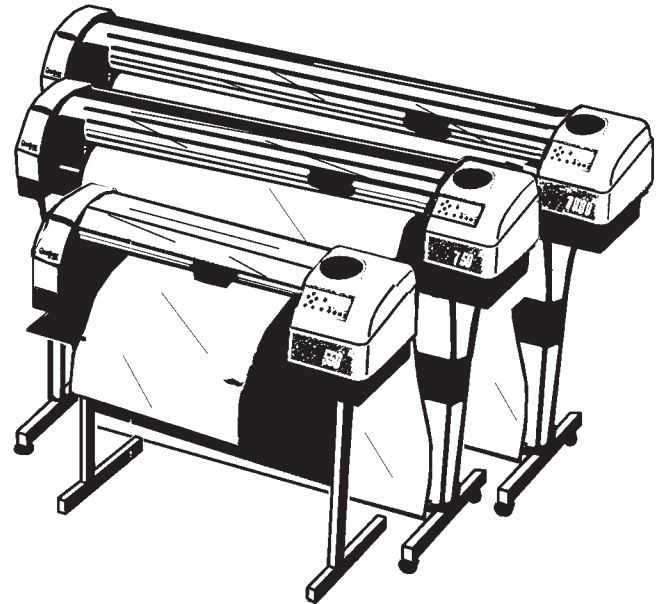

Graphics



GERBER OMEGA GRAPHICS DESIGN & PRODUCTION SOFTWARE

Omega offers the best way to take design through to high quality output using cut vinyl or digital imaging. Omega uses the power of state-of-the-art, 32-bit Windows computing to speed through the creative process. Once finished with a design, that same processing power is combined with Gerber's expertise in cutting and printing techniques to efficiently drive Gerber's devices and many third party plotters.

Omega is available in three different configurations to suit various needs. Omega CL provides basic tools for vinyl cutting. Omega CS adds enhanced cut-vinyl design tools. Omega CP has all of the Omega CS features, plus digital imaging design tools and the ability to drive the Gerber Edge, Edge II and Maxx 2 thermal printers. ImageRIP software option to Omega CP adds the ability to drive large-format inkjet printers. Separate ART Path software can add toolpaths to Omega artwork in order to drive Gerber routers.

OMEGA CP SOFTWARE

Omega CP provides a state-of-the-art set of software tools for graphics design and production, using cut-vinyl plus digital imaging. Omega CP drives the Gerber Edge, Edge II and Maxx 2 providing for virtually unlimited output possibilities.

Import and export images in popular formats, while retaining their vector and fill characteristics for further editing. Work with text and shapes using advanced design tools on an unlimited vertical work surface. Apply stroke and fill colors with click-and-drag ease from on-screen foil palettes. A wide spot color selection is available using GerberColor Spectratone color assignments. Pantone® approved simulations of solid Pantone® colors and multiple tint spot color gradients. Integrated color management ensures consistent color representation from scanned input through to finished production. A fast, multi-tasking plot program sends files to imaging devices and plotters without interfering with work and other jobs at the same time. Omega's plot program also supports automated paneling, repeats, both local and remote output and optional ImageRIP software for large-format inkjets.

P72319A (PAR) / P72631A (USB)

Additional options available separately:

- Gerber ColorID™ Digital color matching software and optional handheld scanner
- ImageRIP software for output to large format inkjet printers
- Additional specialty fonts and graphics libraries
- PostScript file import software option

OMEGA CS SOFTWARE

Omega CS provides a suite of complete software tools for graphics design and production using cut-vinyl. Omega CS drives most Gerber and third-party plotters. All the features of Omega CP are included with the exception of those used for digital imaging. From the raster-to-vector conversion to the customizable Warp Distortion Tool, Omega CS provides the means to explore all the creative possibilities available with vinyl design.

P72324A (PAR) / P72638A (USB)

Additional options available separately:

- Gerber ColorID™ digital color matching software and optional handheld scanner
- Additional specialty fonts and graphics libraries
- Upgrade to Omega CP

OMEGA CL SOFTWARE

Omega CL is an excellent way to start out with computerized specialty graphics design. All the essential features are included, from scanning capability to detail editing tools and tablet support. Powerful, affordable and easy to use, Omega CL is the vinyl shape design and output software that is perfect for computer design beginners. If there is ever a desire to tackle more complex jobs, upgrades are available to add additional functionality.

P72328A (PAR) / P72642A (USB)

Additional options available separately:

- Gerber ColorID™ Digital color matching software and optional handheld scanner
- Additional specialty fonts and libraries
- Upgrade to Omega CS or Omega CP level software

Software Configurations

Detailed software configurations and specifications can be found in the Gerber Catalog available upon request.



GERBER OMEGA MIP SOFTWARE PACKAGES & UPGRADES

Multiple Installation Program (MIP) software packages are available to Omega CP or Omega CS software users. Omega MIP software products are available at substantial savings when compared to purchasing new, single software products. Three variations are available to allow one to outfit the shop with appropriate design and output capabilities. A customer supplied, peer-to-peer network is required to get the full benefit of Omega software products. Gerber will custom-serialize additional Omega MIP software kits to match the serialization of the shop's original Omega. This allows the shop with multiple Omega systems to share fonts, libraries and most software options providing all are at the same software release. Omega also offers the capability of network output support, enabling printing to remote plotters and the Gerber Edge, Edge II or Maxx 2. The original System ID and Omega serial number must be provided at time of order. A hardware security device must be installed for the system to operate and must be specified when ordering as being either parallel port or USB port connected. MIP's are not available for Omega CL users.

OMEGA CP MIP

Omega CP MIP software package is for users with at least one full Omega CP or Omega CS system that want to add additional Omega CP software packages at a substantial discount. Omega CP MIP kit consists of software on CD-ROM, security block and a "Getting Started" manual & Composer Reference Chart.

P72332A (PAR) / P72688A (USB)

OMEGA CS MIP

Omega CS MIP software package is for users with at least one full Omega CP or Omega CS system that want to add additional Omega CS software packages at a substantial discount. Omega CS MIP kit consists of software on CD-ROM, security block and a "Getting Started" manual & Composer Reference Chart.

P72337A (PAR) / P72693A (USB)

OMEGA PS (PLOT STATION™) MIP

Omega PS Plot Station MIP is intended for use as a production only, vinyl output, Gerber Edge, Edge II, Maxx 2 and large format inkjet rendering workstation. It has all software output tools required to manufacture vinyl only and Gerber Edge designs on the appropriate hardware. To output to large format inkjet printers, ImageRIP must be added as an option. With the Gerber Plot and Spooler programs active, this Plot Station becomes an effective network-output server waiting for an Edge job to be spooled to the local Edge, inkjet or plotter.

WITH ArtPath: P72507A (PAR) / P72703A (USB)

WITHOUT ArtPath: P72342A (PAR) / P72698A (USB)

GERBER GRAPHIX ADVANTAGE (GA) TO OMEGA UPGRADES

GA RELEASE 4.X THROUGH 6.X TO OMEGA UPGRADE

Includes Omega password CD-ROM and a full set of manuals.

P72463A (PAR) / P72725A (USB)

GA RELEASE 4.0 OR EARLIER TO OMEGA UPGRADE

GA 4.0 or earlier to Omega with ROS GSP-Configured.

P72457A (PAR) / P72721A (USB)

OMEGA MANUAL LITERATURE KIT

This manual set includes all Omega CP, CS and CL level manuals (including ArtPath) and distortion chart. The above manual sets are not appropriate for Omega PS.

P72447A

OMEGA UPGRADES

Omega Upgrades are "Smart Upgrades". Software automatically identifies the resident Gerber software package and upgrades that software with it's appropriate level and option set to the new Omega features. Omega users with multiple systems are strongly encouraged to upgrade all systems at the same time to allow for seamless file sharing and to take advantage of network functionality. Software upgrades must be purchased for each Graphix Advantage or Omega system being upgraded, including MIP systems.

OMEGA LEVEL-TO-LEVEL UPGRADES

Omega level-to-level upgrades are provided to allow users with previously purchased Omega CS or Omega CL software packages to move up to a higher level of Omega software. GA users can benefit in this program because the movement from level-to-level also includes an Omega upgrade; there is no need to order one separately.

Catalog Number	Level-to-Level Upgrades
P72580A	GA ELITE to OMEGA CP, Parallel Security Block GSP Configured
P72735A	GA ELITE to OMEGA CP, USB Security Block GSP Configured
P72582A	GA SELECT to OMEGA CP, Parallel Security Block GSP Configured
P72737A	GA SELECT to OMEGA CP, USB Security Block GSP Configured
P72584A	GA SELECT to OMEGA CS, Parallel Security Block GSP Configured
P72739A	GA SELECT to OMEGA CS, USB Security Block GSP Configured
P72588A	OMEGA CL to OMEGA CP, Parallel Security Block GSP Configured
P72743A	OMEGA CL to OMEGA CP, USB Security Block GSP Configured
P72590A	OMEGA CL to OMEGA CS, Parallel Security Block GSP Configured
P72745A	OMEGA CL to OMEGA CS, USB Security Block GSP Configured
P72586A	OMEGA CS to OMEGA CP, Parallel Security Block GSP Configured



GERBER OMEGA OPTIONS FOR ALL LEVELS

GERBER COLOR ID SOFTWARE OPTION FOR OMEGA CP

This option allows the user to utilize the power of the Gerber ColorID software and resident color databases to obtain GerberColor Spectratone™ foil matches. Color measuring device hardware is not included with this software option. This option does not directly measure an object to obtain color matches, however, there are powerful ways to utilize it.

P68419A

OMEGA LETTERING MACHINE KIT

w/SMIVB/GX4 LMK PROGRAM MODULE

Allows Omega to output to an existing Gerber Lettering Machine. Interfaces with Signmaker IVB. Includes Job Save Recall to save lettering system job parameters. For use with all Omega systems. Turns SMI/VB/GX4 series lettering systems into output-only devices.

P55100D

OMEGA LETTERING MACHINE KIT

w/GSP SPRINT™ LMK PROGRAM MODULE

Allows OMEGA to output to an existing Gerber Lettering Machine. Interfaces with GSP SPRINT II, GSP SPRINT IIB, SuperSprint™, SuperSprint model B. Includes Job Save Recall to save lettering system job parameters. For use with all Omega systems. Turns GSP Sprint series lettering systems into output-only devices.

P55101D

OMEGA SERIAL PARALLEL BOARD OPTION KIT

Hardware which adds two additional serial (com) ports and a second (LPT) parallel port; these ports are fully configurable to avoid hardware conflict common on today's computers. For interfaces to the Gerber Edge 2, Omega ECP Parallel Board option is required.

P53107D

OMEGA ECP PARALLEL BOARD OPTION

Required where an additional ECP parallel port is needed to connect to the Gerber Edge 2. Only compatible with PCs that have the appropriate ECP-compatible board slot. The parallel-port security device cannot be connected to an ECP port.

P71851C

COLOR ID HARDWARE OPTION

A complete digital color matching product for sign and screen professionals. Using the power of Omega software and the Gerber Edge, this amazing colorimeter measures almost any type of flat colored surface vinyl, paper, plastic or paint and selects the best match to GerberColor Spectratone and Pantone-approved color simulations.

P72445C (Portable) / P72597C (Fixed)

BRILLE INTERPRETER SOFTWARE OPTION

Includes Braille Translation Program, an Omega U.S.A. Braille font and a U.S.A. Braille Relief font for use with GSP Routers.

P66627A

OMEGA DICTIONARY OPTIONS

Spellchecker for Composer Text Entry alerts the operator to misspelled words and provides alternatives.

Available for:

- American English ⁽¹⁾
- British English (ise)
- Danish
- Dutch Preferred Spelling
- German (Doppel:ss)
- Iberian Portuguese
- Norwegian
- Swedish
- Brazilian Portuguese
- British English (ize)
- Dutch
- French
- German (Scharfes:B)
- Italian
- Spanish

NOTE: ⁽¹⁾ Standard with all Omega software products except Omega PS.



GERBER SOFTWARE

MACIMPRINT™ EDGE & PLOTTER OPTION

With MacImprint, Mac users can output to Gerber equipment. Automated settings for the Gerber Edge and plotters are available right from within Adobe® Illustrator®. Create "Gerber Ready" graphic files that print and cut, fast and accurately.

MacImprint driver software can print CMYK images to a Gerber Edge directly from applications such as QuarkXPress™, Macromedia Freehand™ and Adobe® Photoshop®. Individual spot colors can be printed as well. One can also cut graphics on a Gerber plotter using paths drawn on a "cut" layer for those applications that generate vector print commands.

Plug-In features include:

- GerberColor foil CMYK and true spot color swatches
- Automated sequencing of multiple spot color printing to the Gerber Edge
- Edge prompts for each foil cartridge
- Print and cut commands can be sent to an Edge and plotter to save time
- Control of foil color print order
- Assistance with setting separation lines and overlaps for large, paneled images
- Automatic print and cut repetition along the width and length of the material
- Automatic weed border generation

Driver features include:

- Automatic and adjustable settings for full range of materials
- Process & spot colors
- Selectable halftone/LPI
- Rewind after printing
- Reverse print order
- Backing white option
- Overprint option (over entire job)
- Image scaling, mirror image and orientation selection
- Foil conservation control
- Repeats along material path
- Image scaling, mirror image and orientation selections

MACIMPRINT™ DIRECT OUTPUT OPTION

Catalog Number	MacImprint Direct Output Option
P73733A	MacImprint™ 1.1 to 1.2 Upgrade Kit (Free to users registered prior to 4/17/00 only)
P72208A	MacImprint™ 1.2 with Plotter Cable
P73526A	MacImprint™ Gerber Edge USB Cable Option (Includes USB Driver and USB Edge Cable)
P70577C	MacImprint™ Option 1.2 with PCI Card and Plotter Cable

CUSTOM IMAGERIP ICC PROFILES

Custom color correction table for a printer/ink/media combination which is not currently supported by ImageRIP.

IMAGERIP FOR OMEGA OPTION

The best production-oriented large format inkjet Raster Image Processing (RIP) software on the market today. Accepts most image format files (JPG, TIF, BMP, PCX, etc.), Corel® .CMX files and .GAD files from Gerber and third-party developed software for printing on popular, large format inkjet printers such as Encad®, Graphtec®, Mimaki® and Hewlett-Packard®. ImageRIP provides spectacular color prints and has many powerful features, including support for small text, radial and linear fills, strokes and 24-bit color bitmap printing.

P722599A

Additional benefits include:

- High production throughput provided by Rip&Print™ which offers simultaneous job processing and printing
- Offers unlimited print size through continuous-length printing and job paneling
- Superior performance as a 32-bit Microsoft Windows application, including exceptional speed, multi tasking and more
- Decreased production output time through spool file creation for later use
- Increased productivity through batch-processing of multiple inkjet jobs
- Powerful networking capability and compatibility with industry standard ICC profiles

FONTS & FONT LIBRARIES

Gerber offers extensive selection of typefaces for any professional type challenge from decorative and classic styles, to casual and script. Gerber fonts are hand digitized to ensure superlative quality and conformance to architectural and industry standards.

Gerber Edge enhanced fonts:

Gerber's unique Gerber Edge enhanced fonts allows easy creation of signs and graphics of unmatched visual impact. Complete with computerized airbrush and dimensional effects, fades, fill... everything.



SERVICE & SUPPORT

Gerber's philosophy has been to engineer and produce the finest products for the industry. Gerber Service commits to keep all Gerber systems operating at maximum efficiency and to minimize downtime and costs that could negatively effect business.

Why purchase a Gerber Service Plan:

- Minimize equipment downtime so customer deadlines can be met
- Plans are less expensive than flat rate repair charges
- Always better to plan than to react under pressure

Support First™

Acclaimed priority phone support

- Unlimited technical and application assistance by a Senior Technical Systems Support Specialist
- Toll-Free, members only assistance phone number
- Priority queue/Express call back within one hour
- Free express shipment of support disks and media
- Automatic priority mailing of free updates
- National assistance hours of 8 a.m. to 8 p.m., EST, Monday thru Friday
- Special pre-release information on new and updated software
- Members only software upgrade purchase incentives as advertised
- Tech Talk, a periodic newsletter, which includes technical questions, helpful hints, latest company information and more

Graphics

Gerber Service Partners Plan Hardware Service Plan

- Factory labor when equipment is returned to the factory
- Factory parts
- Toll-free priority phone support
- National assistance hours of 8 a.m. to 8 p.m., EST, Monday thru Friday



AFTERMARKET PLOTTER ACCESSORIES

Any accessory is available, please call for others.

Catalog Number	Description	Blade Angle	Put Up	Mfgr.
CAR-BLADE30	Blade, Carbide Technology	30°	1	-
GAP-SC-1030	Blade, Fits Gerber, Anagraph, Excell 1/1m	30°	1	GAP
GAP-SC-1430	Blade, Fits Ioline Studio 7	30°	1	GAP
ARI-BLADE	Blade, Aristo AR20	35°	1	Aristo
GAP-SC-2742	Blade, Fits Gerber GSX	42°	1	GAP
GAP-SC-1345	Blade, Fits All Roland	45°	1	GAP
GAP-SC-1360	Blade, Fits All Roland	60°	1	GAP
GAP-SC-1445	Blade, Fits Ioline Studio 7	45°	1	GAP
GAP-SC-1945	Blade, Fits Western Graphtec FC Series	45°	1	GAP
GAP-SC-3645	Blade, Fits Anagraph Express, Elite	45°	1	GAP
GAP-SC-1145	Blade, Turbo-Cut Blade only. Fits TC1100	45°	1	GAP
GAP-SP-9301	Black Pen, Fits Most Plotters	-	1	GAP
GAP-SP-9302	Blue Pen, Fits Most Plotters	-	1	GAP
GAP-SP-9303	Red Pen, Fits Most Plotters	-	1	GAP
GAP-SP-9501	Black Pen, Fits All Graphtec, etc.	-	1	GAP
GAP-SP-9502	Blue Pen, Fits All Graphtec, etc.	-	1	GAP
GAP-SP-9503	Red Pen, Fits All Graphtec, etc.	-	1	GAP

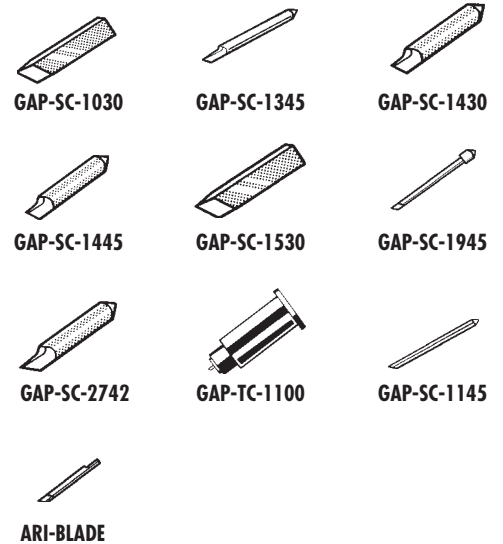

PERFORATED PLOTTER PAPER

GAP tracing paper is a high quality 16lb. paper used to intergrade computer and non-computer information. GAP 20lb. bond paper is for standard rendering general purpose use. GAP white drawing paper is an extra white 2 sided clay coated litho stock which provides an improved image when plotting with felt or GAP Sure-Plot pens. GAP Frisket paper is used for masking surfaces to be painted and for die or hand cut spray mask stencils.

Catalog Number	Description	Width (Inches)	Length (Yards)	Perforation Pattern
GAP-GP-2100	20lb. Bond Paper	30	100	1/2" Pattern
GAP-GP-9000	White Drawing Paper	30	50	1/2" Pattern
GAP-GM200015	Frisket Paper	15	50	Gerber Pattern
GAP-GM200030	Frisket Paper	30	50	Gerber Pattern

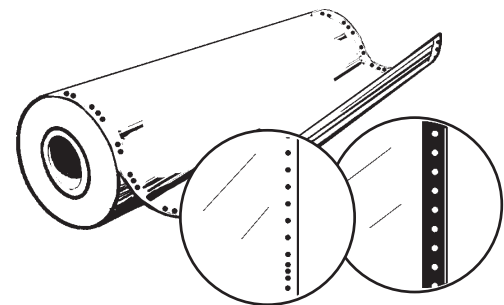

GAP

Graphics

APPLICATION FLUID & VINYL ACESORIES

Wall mount rack GAP-WR1600 holds 16 rolls of film with 3" cores. Roller Tray GAP-RT2400 allows easy rolling of any size material (50lbs. max). GAP-AR-409Q is a natural citrus based solvent developed for the removal of oil and water based adhesives, wax, tar, oil, chewing gum and ink graffiti. MMM-8984Q is a general purpose adhesive cleaner for removing adhesives, silicone, grease, tar, wax and oil. Application fluids help eliminate bubbles and wrinkles when applying vinyl and allows repositioning.

Catalog Number	Description	Mfgr.	Put Up
RAP-TACG	Application Fluid, Gallon	Rapid Tac	1
RAP-TAC32	Application Fluid, 32oz. Spray Bottle	Rapid Tac	1
RAP-REMOVERG	Adhesive Remover, Gallon	Rapid Tac	1
GAP-WR1600	16 Roll Wall Rack	GAP	1
GAP-RT2400	Roller Feed Tray	GAP	1
GAP-AR-409G	"Orange Peel" Adhesive Remover, Gallon	GAP	1
GAP-AR-409Q	"Orange Peel" Adhesive Remover, Quart	GAP	1
MMM-8908-24	Vinyl Woodgrain and Stripe Adhesive Remover, 24oz.	3M	1
MMM-8984Q	Adhesive Cleaner, Quart	3M	1



Application Fluid

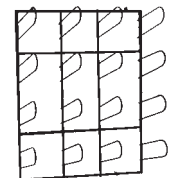

Wall Rack

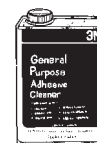

Adhesive Cleaner

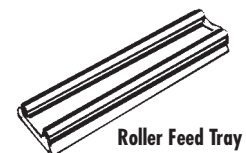

Roller Feed Tray

BELIN SOLID CARBIDE ROUTER BITS**Y. Belin**

Belin high quality solid carbide cutting & milling bits consistently produce crisp lines and exact cuts. Belin bits are specially designed to quickly push chips up and away from the work area. These professional bits are the choice of high production sign shops and offer excellent output rates. Belin offers many different profiles that cut a wide range of materials from aluminum to wood.

Stocked are the most common bits for aluminum milling and for working with plastics, foam boards and wood. Most bits push chips up and away from the cut. See chip direction column below for more information.

Other blade profiles and sizes for other materials also available.

Catalog Number	Application	Cut Length (Inches)	Shank Size (Inches)	Overall Length (Inches)	Chip Direction
BEL-33317A	Aluminum	5/16	1/8	1-1/2	Up
BEL-33317	Aluminum	5/16	1/4	1-1/2	Up
BEL-33476A	Aluminum	1/2	3/16	2	Up
BEL-33476	Aluminum	1/2	1/4	2	Up
BEL-33635	Aluminum	5/8	1/4	2	Up
BEL-13476A	Plastic/Foam Board/Wood	5/8	3/16	2	Up
BEL-13476	Plastic/Foam Board/Wood	5/8	1/4	2	Up
BEL-12476	Plastic/Foam Board/Wood	5/8	1/4	2	Down
BEL-13317A	Plastic/Foam Board/Wood	1/2	1/8	2	Up
BEL-13317	Plastic/Foam Board/Wood	1/2	1/4	1-1/2	Up
BEL-13635	Plastic/Foam Board/Wood	3/4	1/4	2	Up
BEL-13635A	Plastic/Foam Board/Wood	1-1/2	1/4	3	Up
BEL-13635B⁽¹⁾	Foam Board	2-1/4	1/4	3-3/4	Up
BEL-13952A⁽²⁾	Foam Board	3-3/16	3/8	5	Up

NOTE: ⁽¹⁾ Designed to rout/mill 1-1/2" to 2" Foam Board material ONLY.
Reduce the RPM's and Feed Rates [IPM] by 35 to 50% to avoid breakage due to extra long cutting length.

⁽²⁾ Designed to rout/mill 2-1/2" to 3" Foam Board material ONLY.
Reduce the RPM's and Feed Rates [IPM] by 35 to 50% to avoid breakage due to extra long cutting length.





GERBER ROUTING & ENGRAVING BITS

GERBER GOLD ROUTING BITS

Designed for performance and longer tool life. Made to the highest tolerances in the industry. Coated with titanium nitride for durability and superior edge quality for lower tooling cost. Can be used with all Gerber routers/engravers as well as other automated or manual routers.

Two-Flute Spiral Bits

The most versatile type of bit, used for the following materials:

Plate Aluminum, Brass, Bronze, Copper, Cast Acrylics, Solid Surface Materials, Particle Board, Plywood and Hardwood.

Foam Boards, Engraving Stock, P.V.C., Soft Plastics, Soft Woods and Similar Density Materials.

These bits provide excellent chip removal from the cut because of the upward spiral action and also assures excellent edge quality on these materials.

Catalog Number	Shank Dia.	Cutting Dia.	Cutting Edge Lgth.
P50521B	1/8"	1/16"	3/16"
P50525B	1/8"	1/8"	1/4"
P50522B	1/8"	1/8"	1/2"
P52819B	1/8"	1/8"	1-1/4"
P50526B	1/4"	3/16"	3/8"
P50523B	1/4"	3/16"	5/8"
P50528B	1/4"	3/16"	1-1/8"
P50527B	1/4"	1/4"	1/2"
P50524B	1/4"	1/4"	3/4"
P50529B	1/4"	1/4"	1-1/2"
P50530B	1/4"	1/4"	2-1/4"



Single-Flute Radial Bits

Ideal for cutting sheet aluminum and brass with a thickness of .060" (1.5mm) or less, soft woods and soft alloy aluminum. Has a single straight cutting edge which doesn't pull up on the work piece. This allows the bit to shear the chip at the top edge of the material without leaving a burr.

Catalog Number	Shank Dia.	Cutting Dia.	Cutting Edge Lgth.
P50532B	1/4"	1/8"	1/2"
P50533B	1/4"	3/16"	5/8"
P50534B	1/4"	1/4"	3/4"
P50535B	1/4"	1/4"	1-1/2"



GERBER ENGRAVING BITS

High quality long and short type engraving bits. Ideal for applications using Dimension Plus™, Rowmark®, Acrylic, Polycarbonate and other plastic materials.

Engraving Bits • Long Type

For top-loading engraving spindles. Use with Gerber Engraving options.

Catalog Number	Shank Dia.	Cutting Dia.
P47767A	1/4"	.010"
P47769A	1/4"	.020"
P47771A	1/4"	.030"
P47775A	1/4"	.060"
P47777A	1/4"	.090"

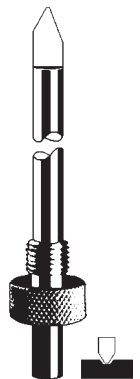

Engraving Bits • Short Type

For bottom-loading collet systems. Use with Router Motor or High Frequency Spindle options.

Catalog Number	Shank Dia.	Cutting Dia.
P50536A	1/4"	.010"
P50537A	1/4"	.020"
P50538A	1/4"	.030"
P50539A	1/4"	.060"
P50540A	1/4"	.090"



Graphics



GERBER ROUTING & ENGRAVING BITS cont.

THREE-FLUTE SPIRAL TAPERED BITS

Yields an angle on the edge of the material. Excellent for cutting vacuum form molds. Can be used to create a "halo" effect without adding additional cost.

Catalog Number	Shank Dia.	Cutting Dia.	Cutting Edge Lqth.	Degree
P50531B	1/4"	1/8"	1/2"	7°
P50643B	1/4"	1/8"	1"	3°



BRAILLE/TACTILE BITS

Used to create ADA (Americans with Disabilities Act) compliant signs. Shank diameter is 1/4" (6.4mm).

Long type bits are used with Dimension 200 and Advantage Router 600 Engraver Options. The short type have the same tip geometry, but are cut shorter for use with the Router Motor or High Frequency Spindle Option.

Cat. No. Long Type	Cat. No. Short Type	Description
P47763A	P47849A	Braille Cutter (used to cut Braille dots)
P50624A	P50622A	.015" Profile Cutter (used to cut ADA sign borders and surface-mounted text)
P50623A	P50625A	.060" Parallel Cutter (used for cutting both letter clean-out pockets in the sign face and matching male characters for Auto-Inlay™ method)

SPECIAL BITS

Table surfacing bit for use with a router motor or high frequency spindle. Its purpose is to mill the sacrificial table surface perfectly flat in respect to the Z axis and aid in precise depth control when cutting.



.750" round nose cutter has a full 3/8" (9.5mm) radius on the bottom for producing a rounded groove for specialty applications or can produce a negative radius on the edge of a piece to be cut out.



.875" V cutter has a 45 degree V-shape for putting a bevel on edges or it can be used for some engraving applications.



Braille Cutter



Profile Cutter



Parallel Cutter

Graphics

Catalog Number	Description	Shank Dia.
P56327A	For Advantage Router 600	1/4"
P50569A	For Dimension 200 Table	1/4"
P26495A	.750" Round Nose Cutter	1/4"
P26496A	.875" V-Cutter	1/4"



V Cutter

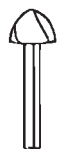

Round Nose Cutter

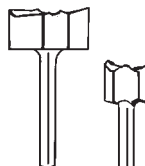

Table Surfacing Bits

AUTO-CARVE 3D CARVING BITS

Creates beautiful slopes and curves that traditional sign carvers produce. Designed for the highest cut quality, maximum cutting efficiency and longest tool life.

Catalog Number	Shank Dia.	Tool Dia.	Tool Degree
P56371A	1/4"	1-1/4"	90°
P56372A	1/4"	1-1/4"	100°
P56373A	1/4"	1-1/4"	110°
P56374A	1/4"	1-1/4"	120°
P56375A	1/4"	1-1/4"	130°
P56376A	1/4"	1-1/4"	140°
P56377A	1/4"	1-1/4"	150°



SABRE ROUTERS

Gerber Sabre series mid-sized routers represent state-of-the-art in dimensional sign-making technology. Sabre series technologically advanced routers are precise, fast, flexible and can be used with many different design programs. With a host of powerful manufacturing functions, Art Path™ quickly and accurately transforms two-dimensional designs into tool paths. Art Path™ file converter can import or export standard file formats such as Adobe Illustrator (.AI), Encapsulated Postscript (.EPS) and Drawing Interchange File format (.DXF) files. Hewlett Packard Graphic Language (.HPGL) files can also be imported. Gerber brand routers are known for premium quality components and a precise, solid machine that will stay "true" and last many years, unlike all other brands.

Sabre mid-sized router features include:

- Advanced technology allows for amazing speed and phenomenal productivity. Servo-driven with 32-bit microprocessor controls provides extraordinary speed, power and output. Anti-backlash lead screw-drives ensure accuracy, dependability, low maintenance and precise tolerances.
- Can be used with Graphix Advantage or other design software; 100' cable included.
- Art Path™ software is provided at no charge with each Sabre router.
- Patented vacuum shroud/pressure foot assembly provides extremely accurate depth control, reduces clamping requirements and creates a cleaner working environment by removing waste chips. Includes all hoses and fittings. Heavy duty wet/dry shop vacuum must be supplied separately.
- Standard motorized Z-axis performs automatic multiple-depth cuts.
- Standard T-slot table with work clamps safely secures materials during cutting.
- Unique job-segmentation feature allows cutting signs of any length.
- Step resolution of .000078" (.0019mm) offers very high quality output.
- Also includes Accessory Kit, Table Slat Kit (installed) and Step Gage.

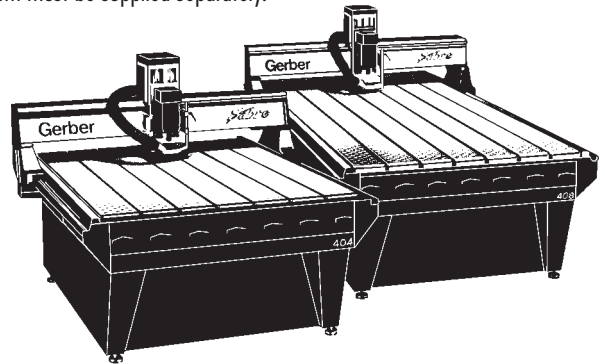

SABRE 404

Sabre 404 features an active cutting area of approximately 54" x 54" (1370mm x 1370mm).

P69356A

SABRE 408

Sabre 408 features an active cutting area of approximately 54" x 100" (1370mm x 2540mm).

P69358A

SABRE 404 WITH T-VAC VACUUM TABLE OPTION

Sabre 404 with T-Vac Vacuum Table incorporates all the features of the Sabre 404 with the addition of an installed vacuum table. T-Vac Table increases productivity by allowing the choice of either vacuum hold-down or mechanical clamps. Includes vacuum table slates, manifold, hoses and fittings. Vacuum pump, filter and control panel must be supplied separately.

P69357A

SABRE 408 WITH T-VAC VACUUM TABLE OPTION

Sabre 408 with T-Vac Vacuum Table incorporates all the features of the Sabre 408 with the addition of an installed vacuum table. T-Vac Table increases productivity by allowing the choice of either vacuum hold-down or mechanical clamps. Includes vacuum table slates, manifold, hoses and fittings. Vacuum pump, filter and control panel must be supplied separately.

P69359A



SABRE ROUTER OPTIONS

When selecting either the Sabre 404 or Sabre 408, either a Spindle Motor or Router Motor option must be selected.

PORTER CABLE MOTOR OPTION

3.25 Porter Cable motor. Includes router motor, wrenches and required mounting hardware. Motor Option includes the following accessory kit in addition to listed components:

- 3 cutting bits 1/8" x 1/4" LOC.
- 3 cutting bits 1/4" x 3/4" LOC.
- 1 .125" collet sleeve.
- 1 .250" collet.
- 1 .500" collet with nut.

P69360A

HIGH FREQUENCY SPINDLE OPTIONS

High frequency spindle options provide infinitely variable speed control and provides quiet operation along with reduced maintenance. Spindle options include spindle, spindle controller, wrenches and required hardware. Refer to the High Frequency Spindle Option fact sheet for additional information. All spindle options also include the following accessory kit:

- 3 cutting bits 1/8" x 1/4" LOC.
- 3 cutting bits 1/4" x 3/4" LOC.
- 1 .125" collet sleeve.
- 1 .250" collet.
- 1 .500" collet with nut.

Catalog Number	Description
P63470A	High Frequency Spindle Option, 3Hp
P61332A	High Frequency Spindle Option, 7Hp 230V
P61337A	High Frequency Spindle Option, 7Hp 380V/460V

SABRE SERIES ENGRAVER OPTION

Adds engraving capabilities to the Sabre router. Improves accuracy for precise engraving work, ADA applications through quiet operation. Includes a belt-driven .250" engraving spindle and motor installed on the carriage in place of the router motor with 2 engraving bits (.030" and .060").

P61851A

ENGRAVER VACUUM SYSTEM OPTION

Chip pick-up system for use with the Engraver option.

P47822D

AUTOMATIC TOOL CHANGER OPTION FOR SABRE 404 & 408

The automatic tool changer (ATC) is designed to increase efficiency and production output for multi-tool cutting applications for the Sabre 404 and Sabre 408 routers. Eliminates the need of manually changing the cutting tools and allows the operator to perform additional tasks during the cutting operation. Automatic Tool Changer option is as beneficial to a one person shop as it is to a large manufacturing facility. ATC system is comprised of a 10hp spindle, 10 tool indexing turret, ATC controller and a spindle controller. This option can be purchased factory installed on a new Sabre or field retro-fitted to existing Sabre routers. Also includes:

- 3 tool holders.
- 3 cutting bits, 1/8" x 1/4" LOC.
- 3 cutting bits, 1/4" x 3/4" LOC.
- 1 .125" collet.
- 1 .250" collet.
- 1 .500" collet.

Factory installed systems must be ordered with new Sabre routers at time of purchase.

Catalog Number	Description
P67295A	Sabre ATC 230V, Factory Installed
P67297A	Sabre ATC 380V/460V, Factory Installed
P67474A	Sabre ATC 230V, Field Installed
P67475A	Sabre ATC 380V/460V, Field Installed

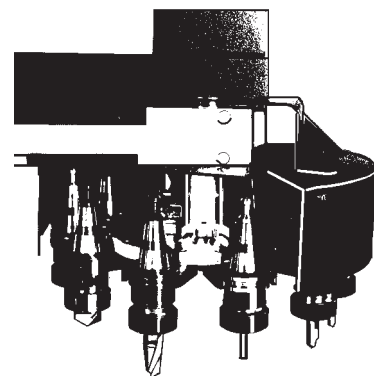

Automatic Tool Changer Option (ATC)

SABRE 404/408 MIST COOLANT OPTION

An innovative coolant system that keeps metals and router bits at an optimum temperature for peak performance. Uses non-toxic GerberCool cutting fluid. Compressed air source must be supplied separately.

P66892A



ADVANTAGE ROUTERS & OPTIONS

ADVANTAGE ROUTER 600

Gerber Advantage Router 600 is designed for routing and engraving plastics, metals and wood. Can be used with many different design programs. With a host of powerful manufacturing functions, Art Path™ quickly and accurately transforms two-dimensional designs into tool paths. The Art Path™ file converter can import or export these industry standard file formats: Adobe Illustrator (.AI) files, Encapsulated Postscript (.EPS) files and Drawing Interchange File Format (.DXF). Hewlett Packard Graphic Language (.HPGL) files can also be imported. Features also include:

- Interfaces directly with the Graphix Advantage; Includes 100' (3.5 meter) cable.
- Art Path™ software.
- 3.25Hp, variable-speed electric router motor and standard router bits.
- Equipped with twin mist coolant applicators and a chip pick-up system. Heavy duty wet/dry shop vacuum required and must be supplied separately.
- 8" (203mm) Z-axis travel, 3.5" (89mm) maximum material thickness.
- 6'-8" x 10' (2 x 3 meters) active cutting area.
- Advantage Router Controller (ARC) with slew keys, a 2-line LCD display and control keys.

P69337A

ADVANTAGE ROUTER 600 w/T-VAC VACUUM TABLE OPTION

Advantage Router 600 with T-Vac Vacuum Table incorporates all the features of the Advantage Router 600 with the addition of an installed vacuum table which increases productivity by allowing for either vacuum hold-down or mechanical clamps. Includes vacuum table slates, manifold, hoses and fittings. 12 individual zones can be separately turned on further, maximizing productivity. Vacuum pump, filter and control panel must be supplied separately.

P69342A

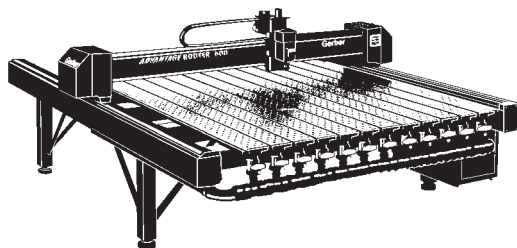

Advantage Router 600
Shown with T-Vac table option

OPTIONS FOR ADVANTAGE ROUTER 600

When selecting the Advantage Router 600 either the Spindle Motor or Router Motor option must be selected.

PORTER CABLE MOTOR OPTION

3.25 Porter Cable motor. Includes router motor, wrenches and required mounting hardware. Motor option includes the following accessory kit, in addition to listed components:

- 3 cutting bits 1/8" x 1/4" LOC.
- 3 cutting bits 1/4" x 3/4" LOC.
- 1 .125" collet sleeve.
- 1 .250" collet.
- 1 .500" collet with nut.

P69347A

HIGH FREQUENCY SPINDLE OPTION

Spindle options below includes the following accessory kit, in addition to listed components. Includes spindle, spindle controller, wrenches and required hardware. Refer to the High Frequency Spindle Option fact sheet for additional information.

High Frequency Spindle option includes spindle, spindle controller, wrenches and required hardware. Also includes:

- 3 cutting bits 1/8" x 1/4" LOC.
- 3 cutting bits 1/4" x 3/4" LOC.
- 1 .125" collet sleeve.
- 1 .250" collet.
- 1 .500" collet with nut.

Advantage Router 600 Engraver Option turns the Advantage Router 600 into an engraver as well with the capability to engrave down to 0.50" (12.7mm) letter height. Includes a belt-driven .250" engraving spindle and motor installed on the carriage in place of the router motor, 2 engraver cutters (.030" and .060"), mounting brackets and an engraving vacuum hose.

P53560A

Engraver Vacuum System Option is a chip pick-up system for the Engraver Option.

Catalog Number	Description
P53560A	High Frequency Spindle Option, 7Hp-230V
P52573A	Engraver Option
P47822D	Engraver Vacuum System Option



ADVANTAGE & SABRE ROUTER SOFTWARE OPTIONS

ROUTER SOFTWARE

Open Architecture Art Path™

For conforming non-Gerber front-end design and hardware packages. Art Path™ is an open architecture software program that makes it possible for shops that have not used an automated router before to start easily, quickly and proficiently.

Art Path™ takes Graphix Advantage/Omega jobs that might otherwise have been cut from vinyl or from standard file formats (.AI, .EPS, .DXF, .HPGL) and allows the addition of all sorts of creative dimensional treatment, right on the screen.

It enables the user to automatically generate tool paths for any PC-driven router from Gerber taking the guesswork out of routing and eliminating material waste. There's even a template function that enables the specification of the tool, depth of pass and router bit feed and plunge rates automatically for whatever material type and size about to be used.

P72507A (PAR) / P72703A (USB)

AUTO-CARVE 3D SOFTWARE FOR ROUTERS

A complete carving package for making traditional carved signs, POP displays, engraving applications, prototypes, personalized products, vacuum forming molds, die making, various signs and more.

Auto-Carve software offers the sign maker three types of carving styles:

- Incised carving for V-bevel shapes and letters.
- Chamfered carving for flat-bottomed shapes and letters.
- Prismatic carving for raised shapes and letters.

Auto-Carve 3D options include:

- 1 120° carving bit.
- Sign Carving training video.
- 12" x 12" Norboard material sample.

NOTE: Art Path™ 6.2 or Omega must be running on the system prior to installation.

P72421A

CUSTOM DIMENSIONAL SIGNAGE CD-ROM

Offers an easy and exiting way to increase profitability and creativity. Jay Cooke, award-winning designer and founder of Vermont Sign School, has developed a one-of-a-kind resource using his more than 20 years of experience.

This interactive, multimedia CD-ROM is a near encyclopedia of information that allows one to search and learn in dozens of areas from traditional hand skills to automated routing.

Custom Dimensional Signage gives you access to photos, video, audio, charts and written content providing a step-by-step review.

P65927C

GERBER BRAILLE INTERPRETER

Translates text from PC's with Omega and Windows 95 (or higher) installed. Includes Braille Translation Program, an Omega U.S.A. Braille font and U.S.A. Braille Relief font.

P72415A





DIMENSION 200 ROUTERS

DIMENSION 200

The Dimension 200 is a small-bed routing system. Ideal for shops that need three-dimensional routing capabilities without the need for a full-sized Gerber routing system. Designed for routing and engraving plastics, metals and woods. Uses a 3.25Hp motor and standard router bits, vacuum shroud/pressure foot assembly and accessory kit. Provides approximately 35" x 31" (900 x 800mm) work area. (2.25" or 57mm maximum material thickness.) Interface cable included. ART Path™ software (serialized option) must be ordered separately, but is provided at no charge when ordered with a Dimension 200.

P53263A

DIMENSION 200 WITH VACUUM TABLE

Dimension 200 with T-Vac vacuum table option.

P53610A

DIMENSION 200E

The Dimension 200E includes all the features of the Dimension 200 with the addition of the engraving option, the engraver vacuum system and the stand assembly. Includes a belt-driven 0.25" engraving spindle and motor along with a standard router motor. This provides the dimension 200E with the capabilities of both an engraver and router.

P53266A

DIMENSION 200E WITH VACUUM TABLE

Dimension 200E with T-Vac vacuum table option.

P53613A

DIMENSION 200X

The Dimension 200X is Gerber's top-of-the-line router/engraver. It includes all the features of the Dimension 200 with the addition of a unique floating Z-axis carriage that allows precise routing and engraving without switching motors. Features also include:

- High Frequency Spindle Option (replaces the standard router motor)
Provides Quiet, Variable Speed Operation up to 28,000rpm.
- Stand Assembly
- 3.25Hp, Variable-speed, Electric Router Motor and Standard Router Bits
- Mist Coolant Option (compressed air source required)

P53269A

DIMENSION 200X WITH VACUUM TABLE

Dimension 200X with T-Vac vacuum table option.

P53616A

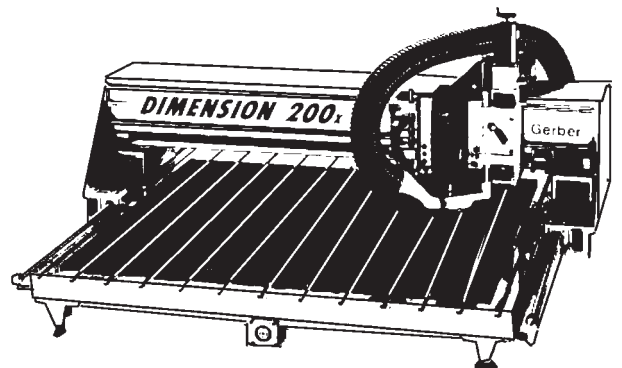
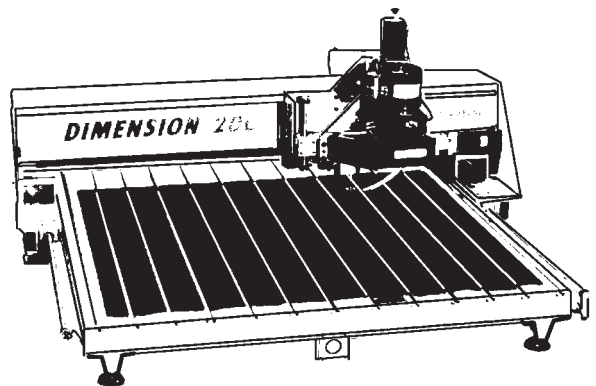
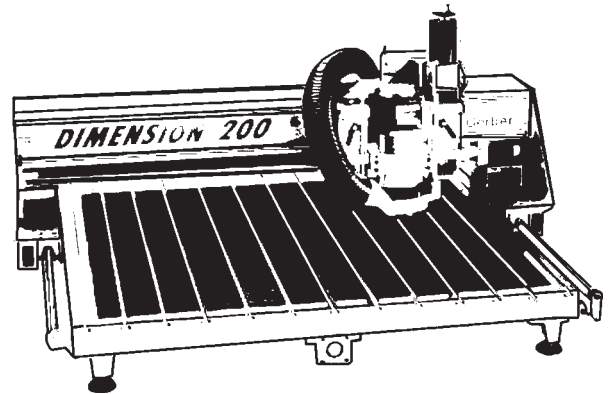



DIMENSION 200 ROUTER OPTIONS & UPGRADES

High Frequency Spindle Option

Includes 1.35Hp spindle, spindle controller, cable and required hardware.

P50131A

Engraver Option

Includes belt driven 0.25" engraving spindle and engraving bits.
For serial numbers above 703,500.

P53659A

Engraver Option

Includes belt driven 0.25" engraving spindle and engraving bits.
For serial numbers below 703,500.

P52575A

Engraver Vacuum System Option

Includes belt driven 0.25" engraving spindle and engraving bits.
For serial numbers below 703,500.

P47822D

Stand Assembly

Metal stand which supports the Dimension 200 at optimum working height.

P46821S

GerberCool Mist Coolant Option

Uses non-toxic GerberCool fluid for metal cutting. Compressed air source must be supplied separately.

P51392D

GerberRouter III to Advantage Router 600 Upgrade

Includes ARC box, power supply, hardware, 100' (30.5m) interface cable and manuals. ART Path™ software is provided at no charge when ordering an Advantage Router 600 upgrade. Call for information regarding GA revision levels and conforming non-Graphix Advantage front-end systems.

P46930A

BLOWER MOTOR PACKAGE

Includes 3.4Hp three phase blower motor, air filter, relief valve and electrical control panel.

ATB1501AK32

BLOWER MOTOR PACKAGE

Includes 2.35Hp single phase blower motor, air filter, relief valve and electrical control panel.

ATB1501AV29Z

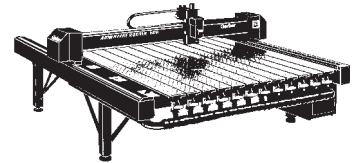
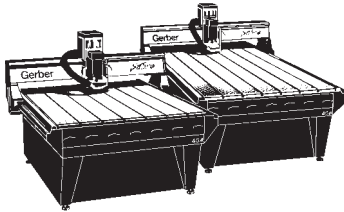

ROUTER ACCESSORIES, TOOLING & SUPPLIES

SABRE 404 & 408 ACCESSORIES

Collet Sleeve, .125" _____	P75886B	Ball Point Pen, Red _____	P32431A
Collet Wrench, Open End Set _____	P41320A	Ball Point Pen, Blue _____	P32432A
Collet, .250" with Nut _____	P48679A	Swivel Knife Assembly _____	P42255A
Collet, .500" with Nut _____	P48680A	Swivel Knife Blade Replacement _____	P42254A
De-burring Tool _____	P50551A	Tool Height Gage _____	P62836B
Pen Assembly _____	P75044B	Work Clamp _____	P62039B
Pen Assembly Spring _____	P26512A	Work Clamp Knob _____	P62041B
Ball Point Pen, Black _____	P32433A	Work Clamp T-Nut _____	P62510B

ROUTER 600 & GERBER ROUTER III ACCESSORIES

Accessory Kit _____	P53830A		
Clamp Knob _____	P40313B	Ball Point Pen, Blue _____	P32432A
Collet Sleeve, .125" _____	P29460A	Ball Point Pen, Red _____	P32431A
Collet Wrench, Open End Set _____	P41320A	Swivel Knife Assembly _____	P42255A
Collet, .250" with Nut _____	P48679A	.500" Diameter Shank _____	
Collet, .500" with Nut _____	P48680A	Swivel Knife Blade _____	P42254A
De-burring Tool _____	P50551A	T-Nut Assembly _____	P26504A
Pen Assembly _____	P75044B	Tool Height Gage _____	P22186B
Pen Assembly Spring _____	P26512A	Work Clamp _____	P21482B
Ball Point Pen, Black _____	P32433A	Work Clamp Nut _____	P42378B

DOUBLE-SIDED ROUTER TAPES

Used to hold smaller work pieces to the router table. Also prevents small cut pieces such as the center of an "O", from being "kicked" from the table.

1" x 60 Yards _____	P71165A
2" x 60 Yards _____	P71166A
3" x 60 Yards _____	P71167A
4" x 60 Yards _____	P71168A

MISCELLANEOUS

Step Gage

Precise initialization tool for materials of varying thickness. Provides exclusive "cut-to-mask" accuracy when used with the Table Slot Kit.

P48560D

Mist Coolant, 1 Gallon

For Trico Mist Coolant Option only.

P50552A

GerberCool, 1 Gallon

For GerberCool Mist Coolant Option only.

P52101A

Serial Line Extender Kit

Extender kits allow distance greater than the standard PC-to-router communications cable length of 100' between the PC and router. Featuring low capacitance cable and serial communication signal boosters. Kits include: 1 ARC box-to-line extender cable, 1 line extender cable, 1 PC-to-line extender cable and 2 serial communication signal boosters.

200' (61 Meters) _____ **P52621D**

300' (91.5 Meters) _____ **P52622D**

400' (122 Meters) _____ **P52623D**

500' (152.5 Meters) _____ **P52624D**

GRAPHIX ADVANTAGE ENGRAVING FONTS



Cannot be used for cutting vinyl.

E - Bauhaus Bold _____	P50093A	E - Harlow _____	P50737A
E - Burgess _____	P50738A	E - Helvetica _____	P39946A
E - Clarendon Bold _____	P50085A	E - Helvetica Medium _____	P50091A
E - Contemporary _____	P39943A	E - Optima Semi Bold _____	P50088A
E - Double Line Century _____	P39945A	E - Roman 4 Line _____	P39947A
E - Dynamo _____	P50094A	E - Single Line Cursive _____	P39951A
E - Full Block _____	P50086A	E - Single Line Helvetica _____	P39949A
E - Futura Bold _____	P50087A	E - Western _____	P50739A
E - Handel Gothic _____	P50089A		

BLOWER MOTOR PACKAGES

Includes 10Hp, 3 phase motor, air filter, relief valve and control panel.

ATB3001AK12

Includes 7-1/2Hp, single phase motor, air filter, relief valve and control panel.

ATB15031AY99

Graphics