

E-Z RIDER®

May 2020

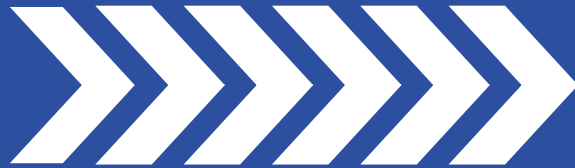

Heavy Duty Clutches

Flywheels & Accessories

Made in the U.S.A.



ACE MANUFACTURING AND PARTS CO.
300 Ramsey Street
Sullivan, MO 63080

For Immediate Assistance
1-800-325-6138

24/7 TECHNICAL SUPPORT

ACE-MFG.COM
customerservice@ace-mfg.com

TABLE OF CONTENTS

E-Z Rider Manual Adjust Features	4
E-Z Rider Self-Adjust Features.....	5
Top Selling Products.....	6
Determining Proper Clutch	7
Metric Push Type Clutch	
310mm and 350mm.....	8
Medium Duty Clutch	
14" Stamped Steel.....	8
14" x 1.75" Cast for Flat Flywheel.....	9
14" x 2" Cast for Flat Flywheel.....	10
14" x 1.75" Cast for Pot Flywheel	11
14" x 2" Cast for Pot Flywheel	11
Heavy Duty Clutch	
15.5" x 2", 8 Spring – Manual Adjust	12
15.5" x 2", 10 Spring – Manual Adjust	13
15.5" x 2", 7 Spring – Manual Adjust and Self-Adjust.....	14
15.5" x 2", 9 Spring – Manual Adjust and Self-Adjust.....	15
NEW ECA Clutch for UltraShift® Plus Transmission	
15.5" x 2", ECA Clutch for UltraShift® Plus.....	16
Flywheels	
Caterpillar	17
Cummins	18-19
Detroit.....	20
Ford-Sterling.....	20
Mack.....	21
Navistar-International	22
Volvo/Mercedes	23
Clutch Accessories	24
Clutch Installation Kits	25
15.5" E-Z Rider Assembly – Exploded View.....	26
Manual Adjust Clutch Installation.....	27
Self-Adjust Clutch Installation.....	31
Maintenance Tips	36
Troubleshooting – Clutch Operation.....	37
Checklist – Before Removing Clutch.....	38
Engine Horsepower & Torque Ratings	39
Contacts	47

E-Z Rider Manual Adjust Clutch

15.5" E-Z Rider Features

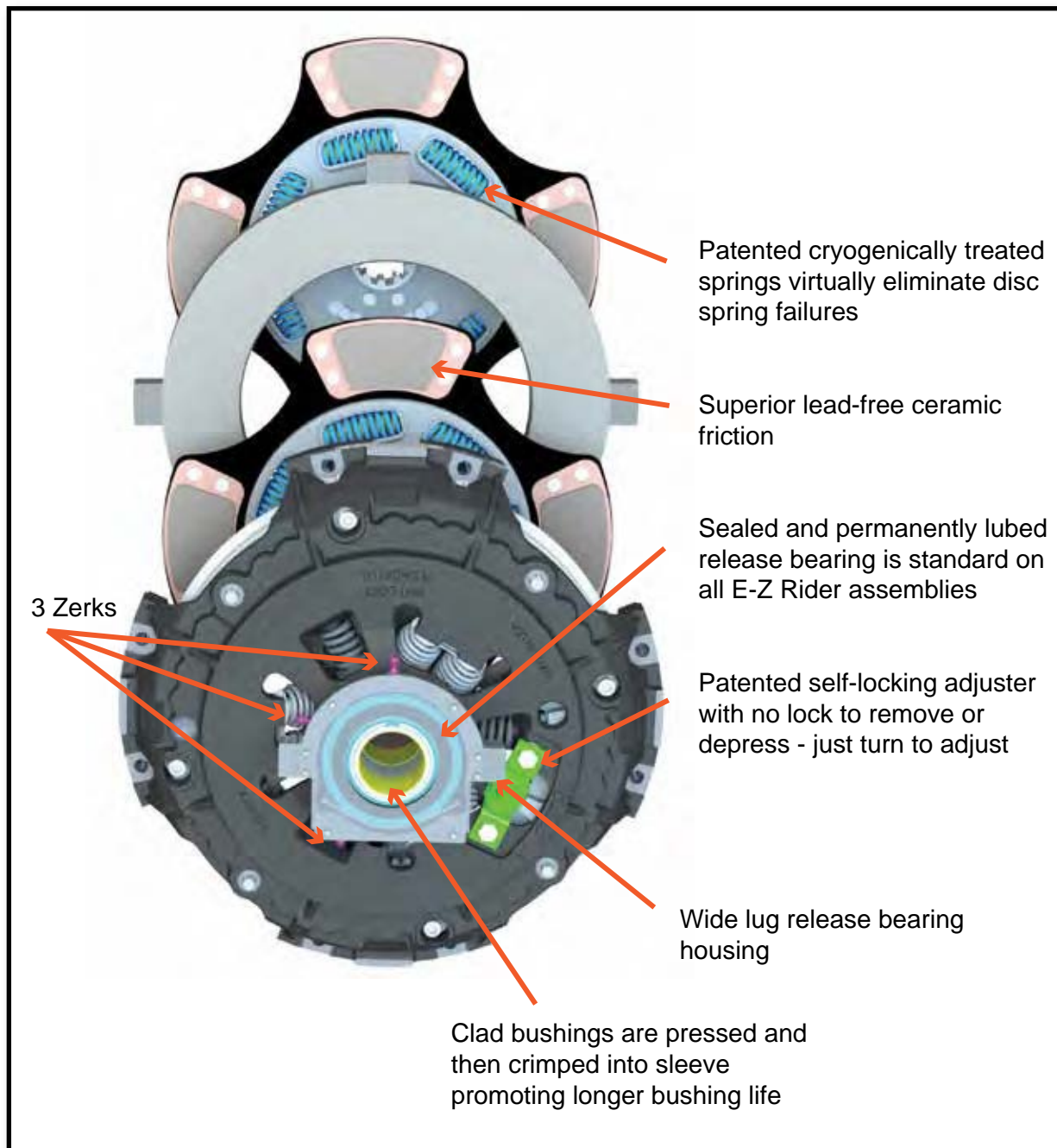

Note: The features above are not included on standard pedal units.

E-Z RIDER®

HEAVY DUTY CLUTCHES

Freedom™ SERIES

Self-Adjust Clutch Design Features

Serviceability

- **No complicated reset procedure**
- **Resets with Manual Adjuster**
- **Same procedure as manual adjust clutch**

Contamination Prevention Technology

- **Self-contained components in adjuster maintain optimal adjusting function**
- **Patent Pending Actively Expanding Seal (A.E.S.) creates an industry first anti-contamination enclosure**
- **Specialized lubrication ensures optimal adjustments throughout the life of the clutch**



Installation

- **No need to retrain technicians**
- **Same installation procedure as manual adjust clutch**

Will NOT over adjust

- **Not susceptible to outside forces (i.e. backing into dock or hitting potholes during disengagement)**

Robust Adjuster Design

- **Positively engaged ratchet system**
- **4-lug drive gear has the capability to deliver over 50 ft*lbs of torque to the adjusting ring**
- **Self-locking worm gear ensures positive adjustment**

How it works

During clutch disengagement, if release bearing travel is 1/2" or less, no adjustment is necessary and the built-in lost release bearing position.

When the clutch wears, release bearing travel increases beyond lost motion window and advances worm gear. The worm gear then turns the adjusting ring to compensate for wear, repositioning the release bearing.

On clutch engagement, one way ratchet advances and restores the ideal lost motion window.

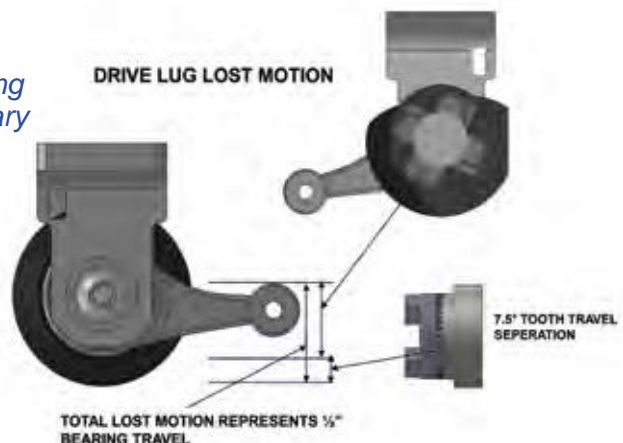

TOP 10 SELLING

CLUTCHES

CLUTCH PART NUMBER	DESCRIPTION
EZ208925-82H	15-1/2" X 2" 7 SPRING, 2050 TORQUE
EZ208925-82B	15-1/2" X 2" 7 SPRING, 1700 TORQUE
EZ208391-74B	15-1/2" X 2" 10 SPRING, 1650 TORQUE
EZ208925-32H	15-1/2" X 2" 7 SPRING NVH, 2250 TORQUE
EZ208391-93B	15-1/2" X 2" 10 SPRING, 1860 TORQUE
EZ208935-51H	15-1/2" X 2" 9 SPRING, 2050 TORQUE
EZ107237-8CB	14" X 1-3/4" 8 SPRING, 900 TORQUE
EZ208391-93H	15-1/2" X 2" 10 SPRING, 2050 TORQUE
EZ208935-51	15-1/2" X 2" 9 SPRING, 1700 TORQUE
EZ107683-5CB	14" X 1-3/4" 8 SPRING, 620 TORQUE

FLYWHEELS

FLYWHEEL PART NUMBER	DESCRIPTION
AF23509709	15" FLAT, DETROIT, SERIES 60
AF1265875	14" FLAT, CAT, 3116/3126
AF1821915C91	14" FLAT, NAVISTAR, DT466E
AF23514177	15" FLAT, DETROIT, SERIES 60 LIGHT
AF1818214C91	14" FLAT, NAVISTAR, 7.3 INTERNATIONAL
AF2569653	15" FLAT, CAT, C15/C16/C18
AF530GB3170	15" FLAT, MACK, E7 E-TECH SERIES
AF4P4797	15" FLAT, CAT, 3406/3406E
AF1810855C93	14" FLAT, NAVISTAR, DT466E
AF3071615	15" FLAT, CUMMINS, M11

ACCESSORIES

PART NUMBER	DESCRIPTION
B201BP	2" 2PC HINGE CLUTCH BRAKE
A240BP	2" 1PC TORQUE LIMITING CLUTCH BRAKE
AB197VBP	PILOT BEARING, VITON SEALED (6306-2VS)
AB197BP	PILOT BEARING, RUBBER SEALED (6306-2RS)
AK2468	MAJOR INSTALL KIT, RT SERIES W/TORQUE LIMITING CLUTCH BRAKE
AB197SBP	PILOT BEARING, RUBBER SEALED FOR MACK (6306-2RSNR)
AB197SVBP	PILOT BEARING, VITON SEALED FOR MACK (6306-SN)
A239BP	1.75" 1PC TORQUE LIMITING CLUTCH BRAKE
AK2468B	MAJOR INSTALL KIT, RT SERIES W/2" 2PC HINGE CLUTCH BRAKE
AK2200	BASIC INSTALL KIT W/2" 1PC TORQUE LIMITING CLUTCH BRAKE

Determining The Proper Clutch For Your Vehicle

1. Determine the size of the clutch. (14" or 15.5")

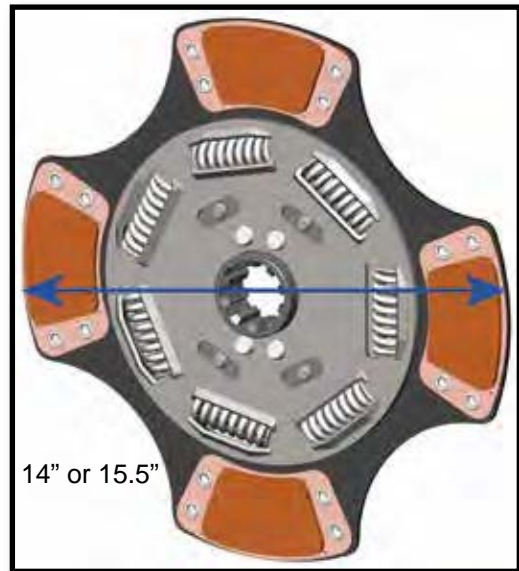
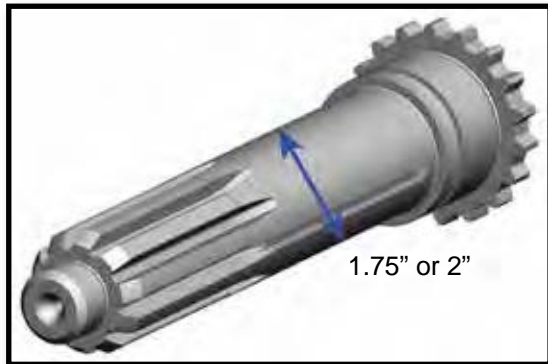

2. Determine flywheel bore by measuring the center of flywheel opening (Dimension 'A' in the illustration). All 14" clutches use 8 spring disc assemblies and can be used only with 7" flywheel bore size regardless of flat or pot style flywheels. For 15.5" clutches, approximate flywheel bore sizes are 7, 8.5" or 10".

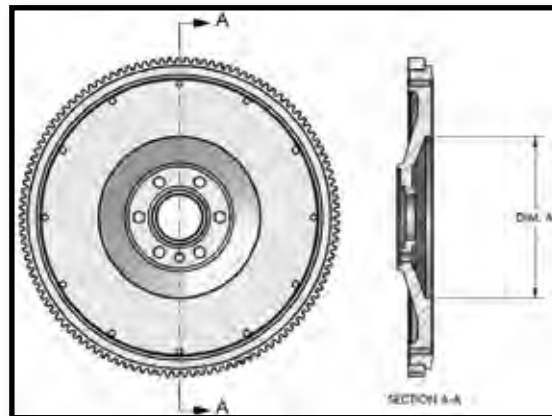

- A.** If flywheel bore is 7", ONLY use an 8 spring disc.
- B.** If flywheel bore is 8.5", use a 10 spring disc.
- C.** If flywheel bore is 10", use a 7 spring (NVH), or a 9 spring (*Mack).
- D.** If you have a 10" flywheel bore, DO NOT USE ORGANIC FACING. The facing I.D. will extend into the flywheel bore opening, not having full facing contact.

3. Determine engine torque at current settings. (See Page 38-Torque Chart)
4. Identify linkage type - Mechanical or Hydraulic. For mechanical linkage you may use either a manual adjust clutch or a self-adjust clutch. Manual adjust clutches are not recommended for hydraulic release systems.

Metric Clutches



DESCRIPTION	TORQUE	DISC STYLE	PART NUMBER
310MM	400	1-1/2" - 6 Springs 4 Paddle	AM107606-1



DESCRIPTION	TORQUE	DISC STYLE	PART NUMBER
350MM	500	1-1/2" - 8 Springs 4 Paddle	AM107621-1
350MM	500	1-3/4" - 8 Springs 4 Paddle	AM107620-2

Medium Duty 14" Stamped Steel Clutch 8 Spring, 7" Flywheel Bore

Dual Disc



TORQUE	DISC STYLE	PEDAL	ADJ	PART NUMBER
860	1-3/4" - 8 Springs 3 Paddle	STD	EZ	AM107237-10
860	2" - 8 Springs 3 Paddle	STD	EZ	AM107342-12

Heavy Duty Clutch for Medium Duty Truck

14" x 1-3/4" For 14" Flat Flywheel 8 Spring, 7" Flywheel Bore

Dual Disc



TORQUE	DISC STYLE	PEDAL	ADJ	PART NUMBER
900	Ceramic 8 Spring 3 Paddle	EZ	EZ	EZ107237-8CB



TORQUE	DISC STYLE	PEDAL	ADJ	PART NUMBER
950	Ceramic 8 Spring 4 Paddle	EZ	EZ	EZ107237-4CB

Single Disc



TORQUE	DISC STYLE	PEDAL	ADJ	PART NUMBER
620	Ceramic 8 Spring 3 Paddle	EZ	EZ	EZ107683-5CB



TORQUE	DISC STYLE	PEDAL	ADJ	PART NUMBER
680	Ceramic 8 Spring 4 Paddle	EZ	EZ	EZ107683-4CB
680	Ceramic 8 Spring 4 Paddle	EZ	EZ	EZ107915-1CB*

*Mercedes Only

14" CAST COVER

Heavy Duty Clutch for Medium Duty Truck 14" x 2" For 14" Flat Flywheel 8 Spring, 7" Flywheel Bore

Dual Disc



TORQUE	DISC STYLE	PEDAL	ADJ	PART NUMBER
900	Ceramic 8 Spring 3 Paddle	EZ	EZ	EZ107686-2CB



TORQUE	DISC STYLE	PEDAL	ADJ	PART NUMBER
950	Ceramic 8 Spring 4 Paddle	EZ	EZ	EZ107686-4CB

VITON Sealed Pilot Bearings

Made with the High Performance Elastomer VITON



**AB197VBP
6306**



**AB197SVBP
6306-S
(Mack Application)**



Excellent Resistance To:

- Petro Chemicals / Fluids
- Extreme Temperatures
- "NOW" A Minimum Requirement By all O.E.M.'S.

14" CAST COVER

14" x 1-3/4" Recessed (Pot) Flywheel



TORQUE	DISC STYLE	PEDAL	ADJ	PART NUMBER
1150	Organic 8 Springs	EZ	DUAL	EZ108035-82B
1150	Organic 8 Springs	STD	STD	107035-82B



TORQUE	DISC STYLE	PEDAL	ADJ	PART NUMBER
1400	Ceramic 8 Springs 4 Paddle	EZ	DUAL	EZ108063-59A
1400	Ceramic 8 Springs 4 Paddle	STD	STD	107063-59A

14" x 2" Recessed (Pot) Flywheel



TORQUE	DISC STYLE	PEDAL	ADJ	PART NUMBER
1250	Ceramic 8 Springs 3 Paddle	EZ	DUAL	EZ108034-61B
1250	Ceramic 8 Springs 3 Paddle	STD	STD	107034-61B



TORQUE	DISC STYLE	PEDAL	ADJ	PART NUMBER
1150	Organic 8 Springs	EZ	DUAL	EZ108034-82B
1150	Organic 8 Springs	STD	STD	107034-82B



TORQUE	DISC STYLE	PEDAL	ADJ	PART NUMBER
1400	Ceramic 8 Springs 4 Paddle	EZ	DUAL	EZ108050-59B
1400	Ceramic 8 Springs 4 Paddle	STD	STD	107050-59B
1400	Ceramic 8 Springs 4 Pad Co - Ft	EZ	DUAL	EZ108050-69B
1400	Ceramic 8 Springs 4 Paddle	STD	STD	107050-69B

15-1/2" x 2" Manual Adjust 8 Spring, 7" Flywheel Bore



TORQUE	DISC STYLE	PEDAL	ADJ	PART NUMBER
1250	Organic 8 Springs	EZ	DUAL	EZ208391-77B
1250	Organic 8 Springs	STD	STD	107391-77B
1400	Organic 8 Springs	EZ	DUAL	EZ208391-82B
1400	Organic 8 Springs	STD	STD	107391-82B



TORQUE	DISC STYLE	PEDAL	ADJ	PART NUMBER
1400	Ceramic 8 Spring 4 Paddle	EZ	DUAL	EZ208391-81B
1400	Ceramic 8 Spring 4 Paddle	STD	STD	107391-81B

15-1/2" x 2" Manual Adjust

10 Spring, 8.5" Flywheel Bore



TORQUE	DISC STYLE	PEDAL	ADJ	PART NUMBER
1450	Organic 10 Spring	EZ	DUAL	EZ208391-78B
1450	Organic 10 Spring	STD	STD	107391-78B



TORQUE	DISC STYLE	PEDAL	ADJ	PART NUMBER
1650	Ceramic 10 Spring 4 Paddle	EZ	DUAL	EZ208391-74B
1650	Ceramic 10 Spring 4 Paddle	STD	STD	107391-74B
1860	Ceramic 10 Spring 4 Paddle	EZ	DUAL	EZ208391-93B
1860	Ceramic 10 Spring 4 Paddle	STD	STD	107391-93B



TORQUE	DISC STYLE	PEDAL	ADJ	PART NUMBER
2050	Ceramic 10 Spring 6 Paddle	EZ	DUAL	EZ208391-93H

15-1/2" x 2" Manual Adjust 7 Spring, 10" Flywheel Bore



TORQUE	DISC STYLE	PEDAL	ADJ	PART NUMBER
1700	Ceramic 7 Spring 4 Paddle	EZ	DUAL	EZ208925-82B
1700	Ceramic 7 Spring 4 Paddle	STD	STD	107925-82B



NVH Disc Shown

TORQUE	DISC STYLE	PEDAL	ADJ	PART NUMBER
2050	Ceramic 7 Spring 6 Paddle	EZ	DUAL	EZ208925-82H
2050	Ceramic 7 Spring NVH 6 Paddle	EZ	DUAL	EZ208925-25
2250	Ceramic 7 Spring NVH 6 Paddle	EZ	DUAL	EZ208925-32H

NEW 14 SPLINE

TORQUE	DISC STYLE	PEDAL	ADJ	PART NUMBER
2250	Ceramic 7 Spring NVH 6 Paddle	EZ	DUAL	EZ208937-32

15-1/2" x 2" Self-Adjust 7 Spring 10" Flywheel Bore



TORQUE	DISC STYLE	PEDAL	ADJ	PART NUMBER
1700	Ceramic 7 Spring 4 Paddle	EZ	DUAL	EZ209925-82B



NVH Disc Shown

TORQUE	DISC STYLE	PEDAL	ADJ	PART NUMBER
1760	Ceramic 7 Spring 6 Paddle	EZ	DUAL	EZ209925-85
2050	Ceramic 7 Spring NVH 6 Paddle	EZ	DUAL	EZ209925-82H

15-1/2" x 2" Manual Adjust 9 Spring, 10" Flywheel Bore



TORQUE	DISC STYLE	PEDAL	ADJ	PART NUMBER
1700	Ceramic 9 Spring 4 Paddle	EZ	DUAL	EZ208935-51*
1700	Ceramic 9 Spring 4 Paddle	STD	STD	107935-51*



TORQUE	DISC STYLE	PEDAL	ADJ	PART NUMBER
2050	Ceramic 9 Spring 6 Paddle	EZ	DUAL	EZ208935-51H*

*Fits Mack and Various Volvo Models. Check Manufacturer's Specifications

15-1/2" x 2" Self-Adjust 9 Spring 10" Flywheel Bore



TORQUE	DISC STYLE	PEDAL	ADJ	PART NUMBER
1700	Ceramic 9 Spring 4 Paddle	EZ	DUAL	EZ209935-51



TORQUE	DISC STYLE	PEDAL	ADJ	PART NUMBER
2050	Ceramic 9 Spring 6 Paddle	EZ	DUAL	EZ209935-51H

*Fits Mack and Various Volvo Models. Check Manufacturer's Specifications

NEW

15.5" x 2", ECA Clutch for UltraShift® Plus Transmission



- **ALL NEW** - No Cores To Handle
- Same Installation Procedures
- Dual Crimped Clad Bushings
- Cryogenically Treated Disc Springs
- Sealed Bearing
- Patented Contamination Prevention
- Proprietary Ceramic Buttons
- 2-Year Warranty

TORQUE	DISC STYLE	ADJ	PART NUMBER
1850	Ceramic 7 Spring 6 Paddle NVH, 14 Spline	DUAL	EZ122002-35A
2250	Ceramic 7 Spring 6 Paddle NVH, 14 Spline	DUAL	EZ122003-42A

Kits Include Low Capacity Inertia Brake

NOTE: SEE ACE-MFG.COM FOR A FULL SET OF INSTALLATION INSTRUCTIONS...

Flywheels

ACE CATALOG # AF4P4797	DESCRIPTION	APPLICATION
	15" FLAT FLYWHEEL 10" BORE 12 MOUNTING BOLT HOLES USE 7 SPRING CLUTCH BEARING # AB197BP (6306) 113 TEETH RING GEAR # 4N2514	CAT 3406/3406E

ACE CATALOG # AF9Y9311	DESCRIPTION	APPLICATION
	14" FLAT FLYWHEEL 7" BORE 10 MOUNTING BOLT HOLES USE WITH 8 SPRING CLUTCH BEARING # AB199BP (6305) OR BEARING # AB190BP (6206) 134 TEETH RING GEAR # 9L8113 OR RING GEAR # 968113	CAT 3208

ACE CATALOG # AF1265875	DESCRIPTION	APPLICATION
	14" FLAT FLYWHEEL 7" BORE 8 MOUNTING BOLT HOLES 1 DOWEL PINHOLE BEARING # AB190BP (6206-2RS) 134 TEETH RING GEAR # 7W5095	CAT 3116/3126

ACE CATALOG # AF4P8515	DESCRIPTION	APPLICATION
	15" FLAT FLYWHEEL 10" BORE 8 MOUNTING BOLT HOLES USE 7 SPRING CLUTCH BEARING # AB197BP (6306) 113 TEETH RING GEAR # 4N2514	CAT 3176, C10, C12

ACE CATALOG #AF2569653	DESCRIPTION	APPLICATION
	15" FLAT FLYWHEEL 10" BORE 12 MOUNTING BOLTS USE 7 SPRING CLUTCH BEARING # AB197BP (6306) 113 TEETH RING GEAR # 4N2514	CAT C15, C16, C18

Flywheels

ACE CATALOG # AF3016495	DESCRIPTION	APPLICATION
	<p>14" POT FLYWHEEL 7" BORE 6 MOUNTING BOLT HOLES USE 8 SPRING CLUTCH BEARING # AB197BP (6306) 103 TEETH RING GEAR # 4797</p>	<p>CUMMINS NT855 SMALL CAM BIG CAM</p>

ACE CATALOG # AF3680922	DESCRIPTION	APPLICATION
	<p>15" FLAT FLYWHEEL 10" BORE 12 MOUNTING BOLTS USE 7 SPRING CLUTCH BEARING # AB197BP (6306) 113 TEETH RING GEAR # 3680913</p>	<p>CUMMINS ISX</p>

ACE CATALOG # AF3042787	DESCRIPTION	APPLICATION
	<p>14" POT FLYWHEEL 7" BORE 8 MOUNTING BOLT HOLES USE 8 SPRING CLUTCH BEARING # AB197BP (6306) 103 TEETH RING GEAR # 4797</p>	<p>CUMMINS L10/M11</p>

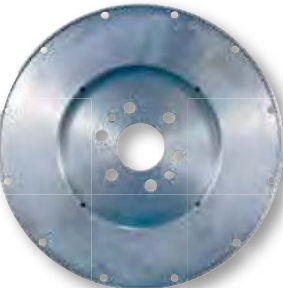
ACE CATALOG # AF3071535	DESCRIPTION	APPLICATION
	<p>15" FLAT FLYWHEEL 10" BORE 6 MOUNTING BOLT HOLES USE 7 SPRING CLUTCH BEARING # AB197BP (6306) 103 TEETH RING GEAR # 4797</p>	<p>CUMMINS NT855 N14</p>

Flywheels

ACE CATALOG # AF3071615	DESCRIPTION	APPLICATION
	<p>15" FLAT FLYWHEEL 10" BORE 8 MOUNTING BOLT HOLES USE 7 SPRING CLUTCH BEARING # AB197BP (6306) 103 TEETH RING GEAR # 4797</p>	<p>CUMMINS M11</p>

ACE CATALOG # AF3921263	DESCRIPTION	APPLICATION
	<p>14" FLAT FLYWHEEL 7" BORE 8 MOUNTING BOLT HOLES USE 8 SPRING CLUTCH BEARING # AB190BP (6206) 173 TEETH .540 THICK RING GEAR # 3903309</p>	<p>CUMMINS 5.9-B</p>

ACE CATALOG # AF3922645	DESCRIPTION	APPLICATION
	<p>14" FLAT FLYWHEEL 7" BORE 8 MOUNTING BOLT HOLES USE 8 SPRING CLUTCH BEARING AB190BP (6206) 138 TEETH .875 THICK RING GEAR # 3902127</p>	<p>CUMMINS 8.3 C Series</p>

Flywheels

ACE CATALOG # AF23509709	DESCRIPTION	APPLICATION
	<p>15" FLAT FLYWHEEL 10" BORE 12 MOUNTING BOLT HOLES USE 7 SPRING CLUTCH BEARING # AB197BP (6306) 118 TEETH RING GEAR # 5166664</p>	<p>DETROIT SERIES 60</p>

ACE CATALOG # AF2354177	DESCRIPTION	APPLICATION
	<p>15" FLAT FLYWHEEL 10" BORE 12 MOUNTING BOLT HOLES USE 7 SPRING CLUTCH BEARING # AB197BP (6306) 118 TEETH RING GEAR # 5166664</p>	<p>DETROIT 60 LIGHTWEIGHT</p>

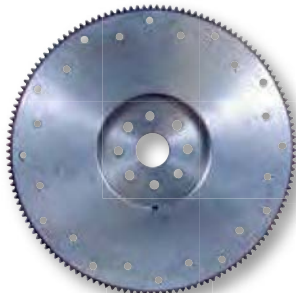
ACE CATALOG # AF8922126	DESCRIPTION	APPLICATION
	<p>14" FLAT FLYWHEEL 7" BORE 8 MOUNTING BOLT HOLES USE 8 SPRING CLUTCH BEARING # AB195BP (6205) 138 TEETH RING GEAR # 5116302</p>	<p>DETROIT 8.2</p>

Ford-Sterling

ACE CATALOG # AFE7HZ6375A	DESCRIPTION	APPLICATION
	<p>14" FLAT FLYWHEEL 7" BORE 8 MOUNTING BOLT HOLES USE 8 SPRING CLUTCH BEARING # AB190BP (6206) 138 TEETH RING GEAR # E6HZ6384A</p>	<p>FORD 6.6 & 7.8</p>

Flywheels

ACE CATALOG # AF530GB3142	DESCRIPTION	APPLICATION
	<p>15" FLAT FLYWHEEL 10" BORE 6 METRIC BOLT HOLES USE 9 SPRING CLUTCH BEARING # AB197SBP (6306-2RSNR) 118 TEETH RING GEAR # 673GB222</p>	<p>MACK 675 & 676</p>

ACE CATALOG # AF530GB3145B	DESCRIPTION	APPLICATION
	<p>15" FLAT FLYWHEEL 10" BORE 6 METRIC BOLT HOLES USE 9 SPRING CLUTCH BEARING # AB197SBP (6306-2RSNR) 118 TEETH RING GEAR # 673GB222</p>	<p>MACK E7</p>

ACE CATALOG # AF530GB3170	DESCRIPTION	APPLICATION
	<p>15" FLAT FLYWHEEL 10" BORE 6 METRIC BOLT HOLES USE 9 SPRING CLUTCH BEARING # AB197SBP (6306-2RSNR) 117 TEETH (2 NOTCHED) RING GEAR # 673GB35</p>	<p>MACK E7 E-TECH SERIES</p>

Flywheels

ACE CATALOG # AF1809144C91	DESCRIPTION	APPLICATION
	<p>14" FLAT FYWHEEL 7" BORE 9 MOUNTING BOLT HOLES USE 8 SPRING CLUTCH BEARING # AB195BP (6205) 137 TEETH RING GEAR # 1800777C1</p>	<p>NAVISTAR 7.3 INTERNATIONAL 6.9 INTERNATIONAL</p>

ACE CATALOG # AF1810855C93	DESCRIPTION	APPLICATION
	<p>14" FLAT FYWHEEL 7" BORE 8 MOUNTING BOLT HOLES USE 8 SPRING CLUTCH BEARING # AB195BP (6205) 138 TEETH RING GEAR # 1815440C1</p>	<p>NAVISTAR DT466</p>

ACE CATALOG # AF1818214C91	DESCRIPTION	APPLICATION
	<p>14" FLAT FLYWHEEL 7" BORE 10 MOUNTING BOLT HOLES USE 8 SPRING CLUTCH BEARING # AB190BP (6206) OR BEARING # AB199BP (6305) 137 TEETH RING GEAR # 1800777C1</p>	<p>NAVISTAR 7.3 INTERNATIONAL</p>

ACE CATALOG # AF1821915C91	DESCRIPTION	APPLICATION
	<p>14" FLAT FLYWHEEL 7" BORE 12 MOUNTING BOLT HOLES USE 8 SPRING CLUTCH BEARING # AB190BP (6206) OR BEARING # AB199BP (6305) 138 TEETH RING GEAR # 1815440C1</p>	<p>NAVISTAR DT466E</p>

Flywheels

Volvo

ACE CATALOG # AF20790714	DESCRIPTION	APPLICATION
	<p>15" FLAT FLYWHEEL 10" BORE 12 MOUNTING BOLTS USE 7 SPRING CLUTCH BEARING # AB197VBP (6306) 153 TEETH RING GEAR # 20711957</p>	<p>VOLVO VED 11</p>

ACE CATALOG # AF20730056	DESCRIPTION	APPLICATION
	<p>15" FLAT FLYWHEEL 10" BORE 14 MOUNTING BOLTS USE 7 SPRING CLUTCH BEARING # AB197BP (6306) 153 TEETH RING GEAR # 20711957</p>	<p>VOLVO VED 12</p>

Mercedes

ACE CATALOG # AF4600300305	DESCRIPTION	APPLICATION
	<p>15" FLAT FLYWHEEL 10" BORE 10 MOUNTING BOLTS USE 7 SPRING CLUTCH BEARING # AB190BP (6206) 160 TEETH</p>	<p>MERCEDES MBE 4000</p>

Clutch Accessories

Part Number	Reference	Description
A119BP	274C-6	Drive Pin 14" Flywheel (6 per bag)
A148BP		2" Brake Spacer (6 per bag)
A153BP		1.75" Brake Spacer (6 per bag)
A239BP	127740	1.75" 1pc Torque Limiting Clutch Brake
A240BP	127760	2" 1pc Torque Limiting Clutch Brake
B175BP		1.75" 2pc Hinge Clutch Brake
B201BP		2" 2pc Hinge Clutch Brake
B201-450BP		2" Oversized 2pc Hinge Clutch Brake .450 thick
B201-500BP		2" Oversized 2pc Hinge Clutch Brake .500 thick
A230EZBP	125300	EZ Adjuster
AB195BP	6205-2RS	Pilot Bearing (rubber sealed)
AB195SBP	6205-2RSNR	Pilot Bearing (rubber sealed for Mack)
AB197BP	6206-2RS	Pilot Bearing (rubber sealed)
AB197SBP	6306-2RSNR	Pilot Bearing (rubber sealed for Mack)
AB197VBP	6306-2VS	Pilot Bearing (Viton sealed)
AB197SVBP	6306-SN	Pilot Bearing (Viton sealed for Mack)
CSB12815BP	12815	Shaft Bushing (4 per bag)
CSF105C-137	105C-137	Release Fork
IG-100-G		Flywheel Gauge
CATLG		Clutch Adjusting Tool
ATK200		Clutch Installation Tool Kit
IPS1659	S-1659	Input Shaft
IPS2822	S-2822	Input Shaft
Alignment		
AT-HT150		1.50 X 10 SPLINE .980 pilot
AT-HT175		1.75 X 10 SPLINE 1.180 pilot
AT-HT175A		1.75 X 10 SPLINE .980 pilot
AT-HT175X1		1.75 X 10 SPLINE 1.0 pilot
AT-HT200		2.00 X 10 SPLINE 1.180 pilot
Installation Kits		
AK2468	RT SERIES	Major install kit w/torque limiting clutch brake
AK2468B	RT SERIES	Major install kit w/2 pc. clutch brake
AK3600	FR SERIES	Major install kit w/torque limiting clutch brake
AK3600B	FR SERIES	Major install kit w/2 pc. clutch brake
AK3762	RT SEVERE DUTY	Major install kit w/torque limiting clutch brake
AK3762B	RT SEVERE DUTY	Major install kit w/2 pc. clutch brake
AK2175	1.75"	Minor install kit w/torque limiting clutch brake
AK2200	2"	Minor install kit w/torque limiting clutch brake
AK2201	2"	Minor install kit w/2 pc. clutch brake



A119BP
DRIVE PIN



CSF105C137
RELEASE FORK



A230EZBP
EZ ADJUSTER



A239BP/A240BP
TORQUE LIMITING CLUTCH
BRAKE



B175BP/B201BP/
B201-450BP/B201-500BP
QUICK CHANGE
HINGE BRAKE



AB195BP/AB197BP/
AB197VBP
PILOT BEARING



AB195SBP/AB197SBP/
AB197SVBP
PILOT BEARING



AT-HT150/AT-HT175/ATHT175A/
AT-HT175X1/AT-HT200
ALIGNMENT TOOL



IPS1659, IPS2822
INPUT SHAFT 2"
10 SPLINE W/BUSHING



A148BP/A153BP
FIBER BRAKE SPACER



CATLG
CLUTCH ADJUSTING TOOL



IG-100-G
FLYWHEEL GAUGE



CSB12815BP
BUSHING - BELL HOUSING

Basic Clutch Installation Kit



Part #AK2175 Includes:

- (1) CSF105C137 Fork
- (1) A239 1.75" Torque Limiting Clutch Brake
- (4) CSB12815 Bushings

Part #AK2200 Includes:

- (1) CSF105C137 Fork
- (1) A240 2" Torque Limiting Clutch Brake
- (4) CSB12815 Bushings

Part # AK2201 Includes:

- (1) CSF105C137 Fork
- (1) B201 2" Hinged Clutch Brake
- (4) CSB12815 Bushings

Complete Clutch Installation Kit



For FR Series Transmissions

Part #AK3600 Includes:

- 2" Torque Limiting Clutch Brake (A240) and Roller Bearing

Part #AK3600B Includes:

- 2" Hinged Clutch Brake (B201) and Roller Bearing

For RT Series Transmissions

Part #AK2468 Includes:

- 2" Torque Limiting Clutch Brake (A240) and Ball Bearing

Part #AK2468B Includes:

- 2" Hinged Clutch Brake (B201) and Ball Bearing

Part #AK3762 Severe Duty Includes:

- 2" Torque Limiting Clutch Brake (A240) and Roller Bearing

Part #AK3762B Severe Duty Includes:

- 2" Hinged Clutch Brake (B201) and Roller Bearing

This clutch installation kit includes the following:

- Clutch Housing Gasket
- Front Bearing Cover Gasket
- Inner Retaining Ring
- Outer Retaining Ring
- Front Bearing Cover
- 2" Torque Limiting Clutch Brake
- Shift Lever Housing Gasket
- Bearing w/Snap Ring
- Pilot Bearing
- Cross Shaft Bushings
- Standard Release Yoke
- 2" - 10 Spline Input Shaft

15.5" E-Z RIDER® Assembly

1. Adjuster

- a. Gear used to manually turn adjusting ring

2. Release Bearing Assembly

- a. Release bearing centered in housing
- b. Forks pull on housing to release clutch sleeve

3. Sleeve Spring

4. Cover Assembly

- a. 6 Spring standard pedal
- b. 9 Spring easy pedal
- c. Houses all internal clutch parts
- d. Often referred to as pressure plate

5. Adjusting Ring

- a. Threads into cover assembly
- b. Has 6 lever saddles
- c. Repositions levers when adjusting clutch for proper plate load and release to compensate for wear

6. Pressure Springs

- a. Springs put pressure on retainer to achieve proper plate load for unit
- b. Units have 6 pressure springs with total plate loads ranging from 2400 to 4000 lbs.
- c. Located between retainer and cover assembly

7. Assist Springs

- a. 3 Springs located between retainer and cover to assist in pedal effort when releasing clutch
- b. Easy pedal only

8. Spring Pivots

- a. Fits over machined surfaces on retainer and cover assembly for smooth spring action and to reduce wear

9. Retainer

- a. All internal clutch components connect to retainer to release the clutch
- b. The retainer is pulled, compressing pressure springs and pivoting levers allowing pressure to be removed from pressure plate, thus allowing the clutch release

10. Thrust Washer

11. Levers

- a. 6 levers per unit located between retainer and saddles on adjusting ring
- b. Apply or remove pressure from pressure plate by pivoting on the fulcrum of the pressure plate

12. Sleeve

- a. Sleeve connects release bearing to retainer by bevel on sleeve
- b. Sleeve has 2 brass bushings pressed and indented. Bushings require lubrication to ensure long life.

13. Pressure Plate

- a. Applies clamping force from cover assembly to discs and center plate against flywheel
- b. Plate is held in place by straps bolted to plate and riveted to cover

14. Clutch Discs

- a. Drives the input shaft through a splined hub
- b. Buttons refer to friction material looking like pads, pucks, or buttons
- c. Can have non-asbestos organic facing
- d. Dampens with 7, 8, 9, 10 dampening springs
- e. Have 4 or 6 sets of buttons

15. Intermediate Plate

- a. Used on dual disc clutch, adds friction surface to increase torque while absorbing heat
- b. The intermediate plate fits in cover assembly with lugs machined on plate and slots corresponding in cover

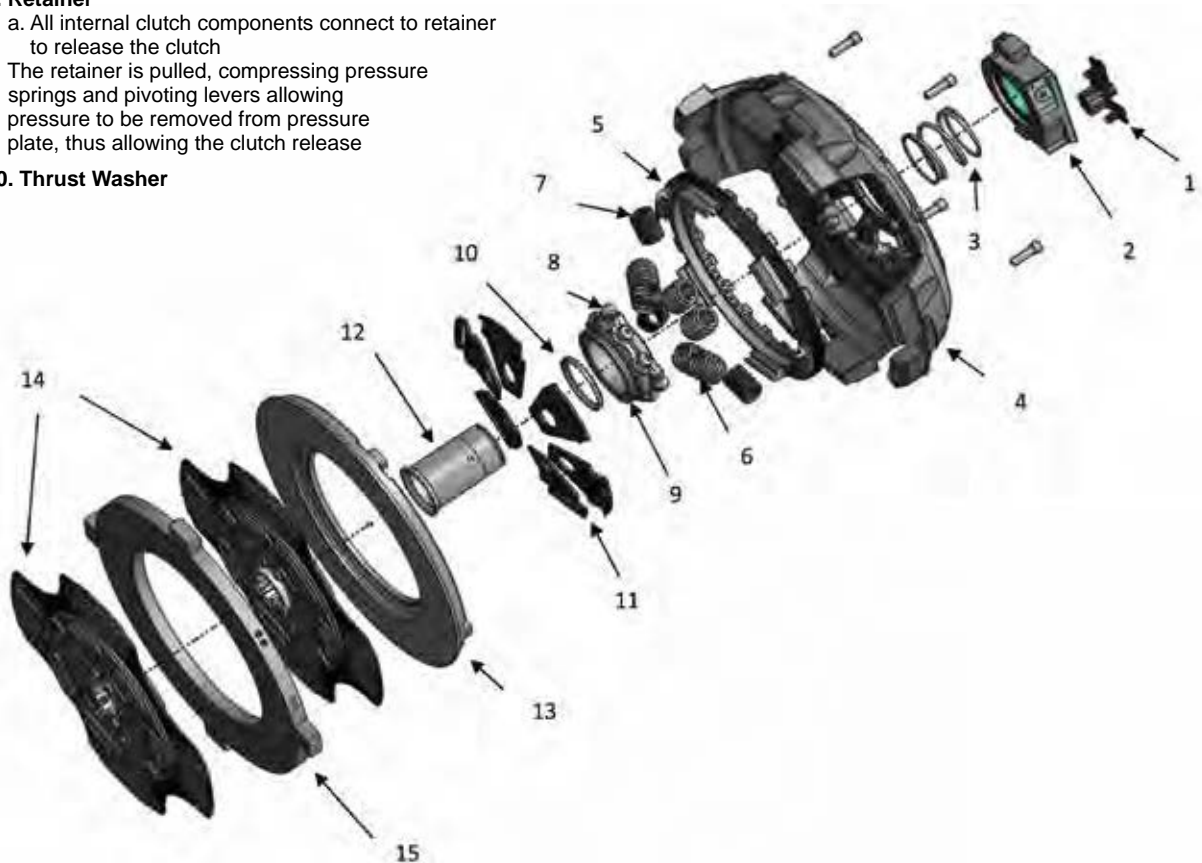

ACE MANUFACTURING & PARTS CO., INC. 300 Ramsey - Sullivan, MO 63080
Phone: (573) 468-4181 • Fax: (573) 468-5584



Manual Adjust Clutch Installation Guide

STOP

READ CAREFULLY BEFORE INSTALLING CLUTCH

This clutch must be installed by a qualified installer. Improper installation or failure to replace or resurface the flywheel, or to replace the pilot bearing, clutch brake or other worn drive train components may cause poor clutch release or early failure and void the manufacturer's warranty.

Verify Correct Flywheel Dimensions

Measure the flywheel bore to determine if you have the correct clutch for your application (Fig. 1). This dimension will be 7", 8.5", or 10".

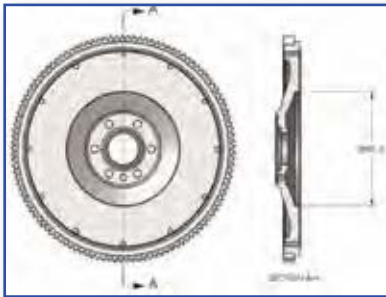

Fig. 1

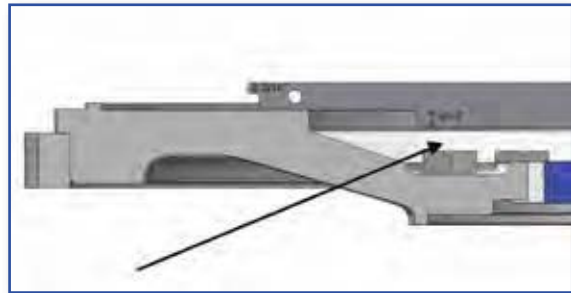

Fig. 2

You must have a minimum of 5/16" distance from the friction surface (face) of your flywheel to the top of the bolt head that holds the flywheel to the crankshaft. If it is less than 5/16", you need a NEW flywheel! (Fig. 2)



Fig. 3

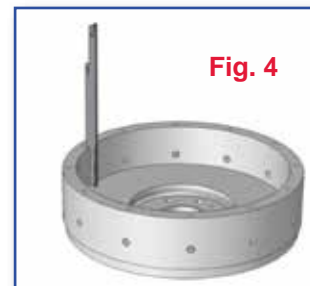

Fig. 4

Flywheel clutch pilot cannot be greater than 3/16" deep. If it is greater than 3/16" the clutch will not bolt tight to flywheel. (Fig. 3)

14" POT Flywheel dimension is 2.937. (Fig. 4)

INSTALLATION

1. Resurface or replace flywheel. Surface must be smooth or premature clutch failure can occur.
REMEMBER: Machining the flywheel past the recommended .060" moves the pressure plate away from the transmission. In this event, install a fiber spacer (provided) on the input shaft between the clutch brake and the transmission. The release yoke in the bell housing may not align properly with the pressure plate release bearing housing. Linkage adjustment may be required during clutch setup. If resurfacing is required, while the flywheel is mounted to the crank shaft, verify correct flywheel dimensions referencing page 1.
2. (14" Pot Style Only) Drive pins in the flywheel must be replaced. Check and be sure drive pin heads are square with the flywheel friction surface. (If drive pins are not replaced, assume that they are not square. The constant pounding of the center plate may have changed the position of the drive pins in the flywheel. Play it safe—Replace them all!)

3. (14" Pot Style Only) After the drive pins are installed and properly aligned, position the center plate onto the drive pins and check the clearance with a feeler gauge. Clearance should be .006" to .010" and be measured from the same side of the drive pin at each location. The center plate should move up and down freely on the pins.
4. Inspect and dial-indicate the mating surface of engine flywheel housing and clutch bell housing for alignment. Check flywheel run out. **CAUTION: If misalignment is greater than the recommended limits, this will cause poor clutch release, rapid wear on transmission input shaft and destruction of the clutch disc.** Excessive flywheel run out may cause severe vibration in vehicle drive line. (Fig.5)
5. A new pilot bearing with a VITON® seal must be used. Before installing pilot bearing into flywheel, check freedom of movement on transmission input shaft.
6. Verify disc fits in flywheel bore (Fig. 1). Slide disc the length of the input shaft checking for twist and wear. Insert alignment shaft through bearing housing. Install rear disc (oriented correctly), center plate, and front disc (oriented correctly) on alignment shaft. Move clutch housing towards flywheel making sure cover fits into flywheel pilot.
7. Install the bolts that fasten the clutch housing on the flywheel. Tighten the bolts to the specified torque and the sequence specified by the manufacturer of the vehicle or transmission (7/16 x 14unc x 2-1/4 recommended 40-50 ft*lbs) (3/8 x 1 1/4 recommended 25-35 ft*lbs.) Bolts should be Grade 5 or greater.
8. Remove caging fork from under the release bearing. Remove alignment shaft. Verify bearing distance from cover is 1/2" - 5/8" (Fig. 6). **NOTE: Any time the clutch is removed from the flywheel, the caging fork needs to be reinstalled.**
9. Reconnect lube hose attachment (For Hydraulic Linkage Systems).

MEASURING ENGINE FLYWHEEL HOUSING AND FLYWHEEL

NOTE: Pilot Bearing must be replaced. Make sure all gauge contact surfaces are clean and dry.

CHECK THE FOLLOWING USING A DIAL INDICATOR:

Fig. 5



Flywheel Face Runout

Secure dial indicator base to flywheel housing face. Put gauge finger in contact with flywheel face near the outer edge. Rotate flywheel one revolution. Maximum runout is .008" (.20 mm).



Flywheel Housing Face Runout

Secure dial indicator base to flywheel near the outer edge. Put gauge finger in contact with face of flywheel housing. Rotate flywheel one revolution. Maximum runout is .008" (.20 mm).



Pilot Bearing Bore Runout

Secure dial indicator base to flywheel housing face. Position gauge finger so that it contacts pilot bearing bore. Rotate flywheel one revolution. Maximum runout is .005" (.13 mm).



Flywheel Housing I.D. Runout

Secure dial indicator base to crankshaft. Put gauge finger against flywheel housing pilot I.D. Rotate flywheel one revolution. Maximum runout is .008" (.20 mm).

Fig. 6

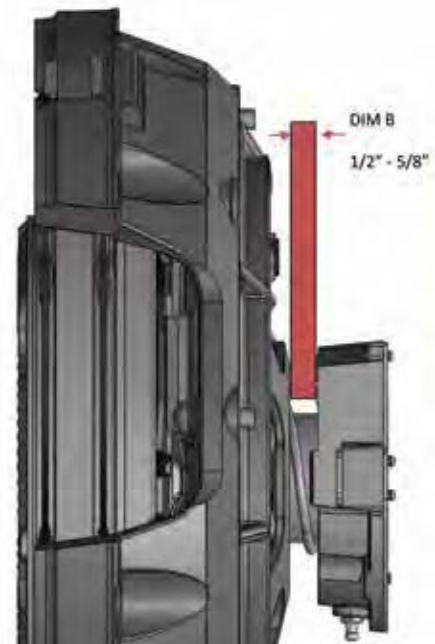

10. Examine transmission input shaft and clutch release system components for wear and replace if necessary. (Fig. 7)
11. Install fiber spacer and replace clutch brake (fiber spacer not needed if over-sized clutch brake is used).

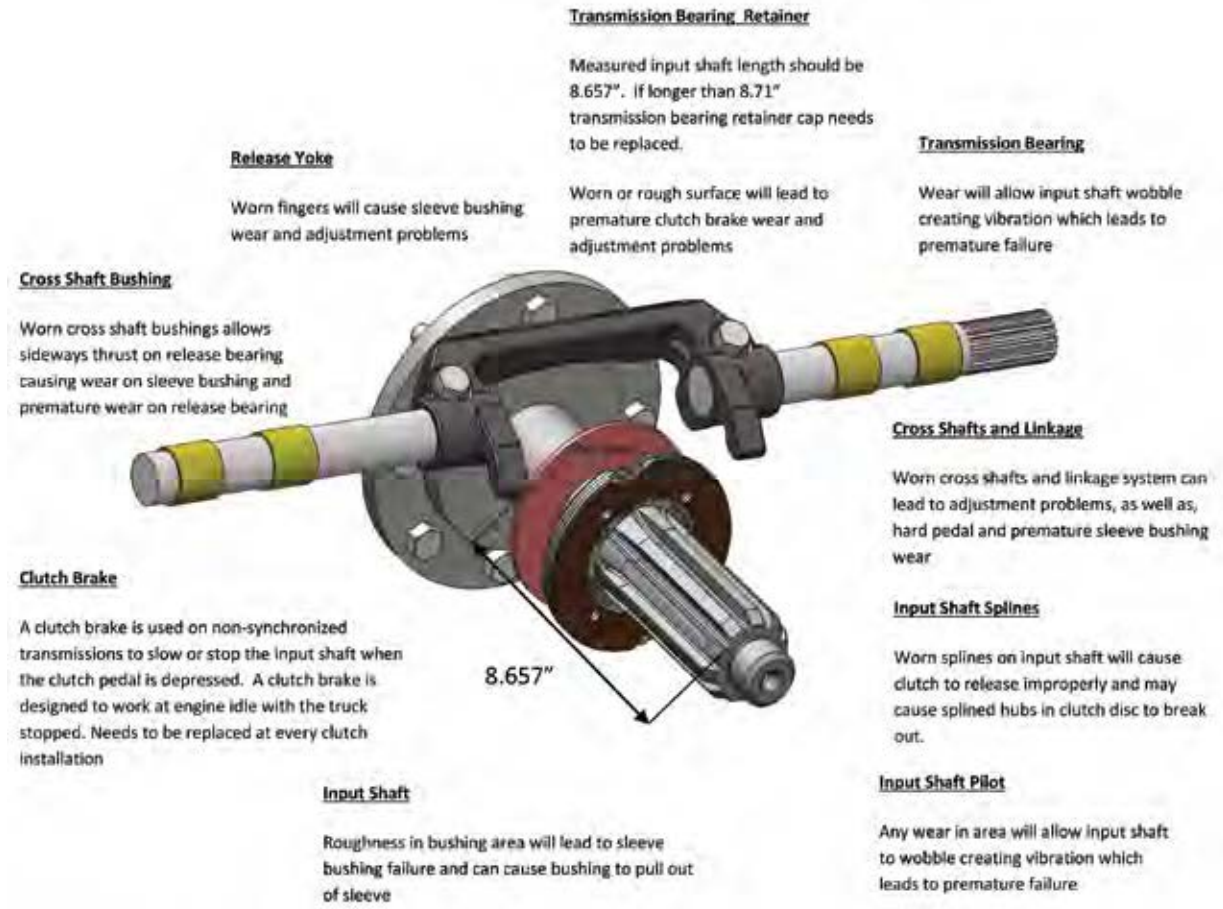

12. Be sure to properly lube the following components with NLGI grade 2 or 3 Lithium complex grease: Release Bearing, Yoke Fingers, Cross Shaft Bushings, and Linkage Pivot Points. Note: Applying enough grease to the release bearing until visible will extend the life of sleeve bushings and input shaft.
13. Using extreme caution, guide transmission through clutch cover, disc assemblies, and into pilot bearing rotating bell housing shaft so that release yoke fingers are clear of the pads on the release bearing assembly. **(Warning: Transmission must not hang or be forced into the clutch. This can warp the clutch disc and prevent the clutch from releasing.) NOTE: Do not add lube to input shaft splines!**
14. Start bell housing bolts and tighten progressively to the torque recommended by the vehicle manufacturer.
15. Install clutch linkage. See "Clutch Set Up Procedure".

CLUTCH SET UP PROCEDURE

NOTE: Clutches are adjusted at the factory to original equipment specifications and should require very little internal adjustment to achieve proper release and engagement. The clutch must not be adjusted to accommodate thin or worn flywheels, or worn linkage, yoke and/or cross shaft bushings, or to accommodate other drive train deficiencies. Adjustment for such purposes will either cause the clutch to not function properly or will cause early clutch failure and will be apparent on factory inspection of warranty claims, thereby voiding the manufacturer warranty.

STEP #1

After transmission installation, check the clearance between the yoke tips and wear pads on bearing housing for 1/8" clearance. This determines pedal free play (Mechanical Linkage Only). (See Fig. 8)

Adjust the clutch linkage to increase or decrease the yoke-to-bearing clearance. **NEVER USE THE INTERNAL CLUTCH ADJUSTMENT FOR THIS PURPOSE.**

STEP #2

Check for proper clutch brake and bearing gap of 1/2" to 9/16". If the gap is too small verify DIM B (Fig. 6 or Fig. 8). If DIM B is correct and a fiber spacer or oversized clutch brake was installed, remove the fiber spacer and/or replace over-sized clutch brake with standard thickness clutch brake. **NOTE: If the gap is larger than 9/16" and DIM B is correct then one of the following conditions exists. Fiber spacer/over-sized clutch brake was not installed or you need to re-measure input shaft length as seen in Fig. 7. DO NOT ADJUST THE CLUTCH**

THIS DIMENSION IS CRITICAL. DO NOT VARY—EITHER OVER OR UNDER THESE DIMENSIONS—UNDER ANY CIRCUMSTANCES.

REMINDER: The bearing must move a minimum of 1/2" or clutch will not release. Eliminate lost motion before checking for 1/2" movement. Lost motion is generally caused by loose or worn linkage, or worn yoke or cross shaft bushings.

STEP #3

Verify the clutch brake squeeze by inserting .010 feeler gauge between bearing and clutch brake, then depress the pedal to end of stroke. The feeler gauge must be tightly clamped between the bearing and the clutch brake. This verifies the contact of the bearing to the clutch brake.

The clutch brake will be squeezed if the total pedal stroke slightly exceeds the movement required to move the yoke/fork 5/8" to 11/16" (the combined total of the 1/8" clearance between yoke tips and wear pads and the 1/2" - 9/16" brake squeeze gap). To optimize brake squeeze slowly let up on the pedal and check the pedal position at the moment the .010" feeler gauge can be removed. If the pedal is less than 1/2" or more than 1" from the floor when gauge can be removed, re-adjust the linkage.

IN THE EVENT THE BRAKE IS NOT BEING SQUEEZED, DO NOT CHANGE THE 1/2" - 9/16" GAP FOR THE CLUTCH BRAKE, OR THE 1/8" CLEARANCE FOR THE BEARING HOUSING—CONSULT THE VEHICLE MANUFACTURER SERVICE MANUAL.

In analyzing the reasons for the brake not being squeezed, other things to check for are:

- Worn linkage components or yoke and cross shaft bushings. If necessary, replace those components.
- Improper linkage assembly. Verify that linkage is assembled in the correct hole locations.
- Pedal stroke. To adjust raise the upper and/or lower the lower pedal stops.
- If the clutch is hydraulically assisted, make sure the slave and master cylinders are functioning properly.

NOTE: MAXIMUM BRAKE SQUEEZE (IN CAB OF TRUCK) SHOULD NOT EXCEED 1" FROM THE END OF PEDAL STROKE. IF IT DOES, IT CAN BE ADJUSTED BY:

- Changing pedal stops in cab to reduce total pedal stroke.
- Increasing 1/8" yoke-to-bearing setting to lower squeeze. (This will increase free-pedal travel.)

STEP #4

Installer should carefully verify that there is 1/2" - 5/8" gap between clutch cover and release bearing, 1/8" of free travel between yoke and wear pads (mechanical linkage only), and 1/2" - 9/16" gap between release bearing and clutch brake.

TROUBLESHOOTING AND DIAGNOSTICS

Bearing to Cover Position too large (Greater than 5/8")

- Disc in backwards
- 5/16" flywheel dimension is too small and disc is hitting crank bolts (Fig. 2)
- Flywheel bore is smaller than clutch disc (Fig. 1)
- 14" POT Flywheel 2.937 dimension is not correct (Fig. 4)

Bearing to Cover Position too small (Less than 1/2")

- Flywheel not resurfaced
- Flywheel clutch pilot is more than 3/16" (Fig. 3)
- Forgot to install a disc
- 14" POT Flywheel 2.937 dimension is not correct (Fig. 4)

Bearing to Clutch Brake Gap is greater than 9/16"

- Verify bearing position is in spec between 1/2" - 5/8" (Fig. 8)
- Input shaft measurement is too long/excessive wear on transmission input bearing retainer (Fig. 7)
- Did not use over-sized clutch brake or fiber spacer

Bearing to Clutch Brake Gap is less than 1/2"

- Verify bearing position is in spec between 1/2" - 5/8" (Fig. 8)
- Used over-sized clutch brake instead of standard clutch brake
- Using fiber spacer and don't need it

Free Travel is out of spec (Mechanical Linkage Systems Only)

- Verify Bearing Position is in spec between 1/2" - 5/8" (Fig. 8)
- Verify Bearing to Brake Gap is in spec between 1/2" - 9/16" (Fig. 8)
- Release system linkage components are worn; need to be adjusted or replaced (Fig. 8)

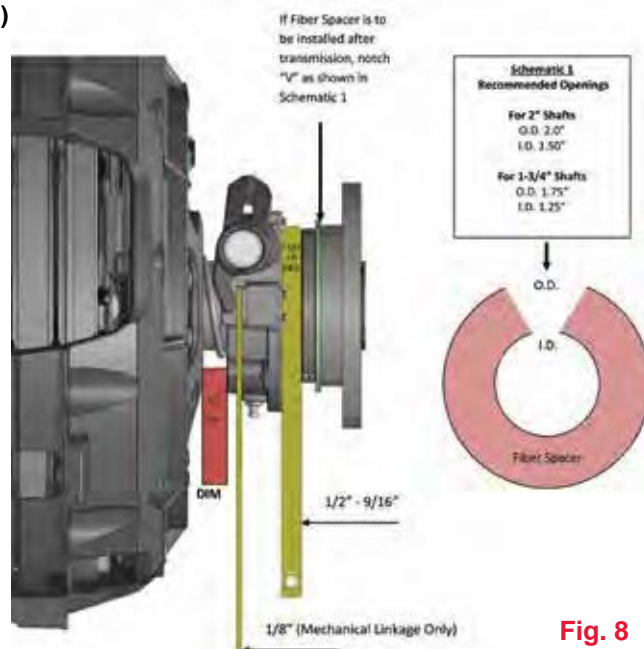

Fig. 8



Self Adjust Clutch Installation Guide

STOP

READ CAREFULLY BEFORE INSTALLING CLUTCH

This clutch must be installed by a qualified installer. Improper installation or failure to replace or resurface the flywheel, or to replace the pilot bearing, clutch brake or other worn drive train components may cause poor clutch release or early failure and void the manufacturer's warranty.

Verify Correct Flywheel Dimensions

Flywheel bore (DIM A) must be a minimum of 10". (Fig. 1)

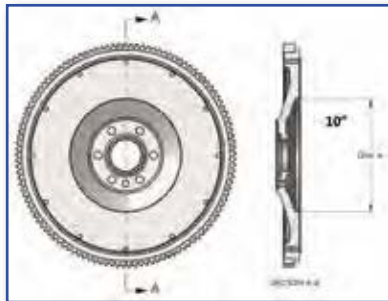

Fig. 1

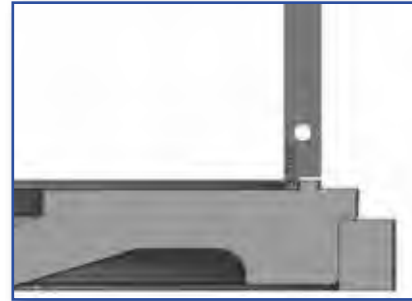

Fig. 2



Fig. 3

You must have a minimum of 5/16" distance from the friction surface (face) of your flywheel to the top of the bolt head that holds the flywheel to the crankshaft. If it is less than 5/16", you need a NEW flywheel! (Fig. 3)

Flywheel clutch pilot cannot be greater than 3/16" deep. If it is greater than 3/16" the clutch will not bolt tight to flywheel. (Fig. 2)

INSTALLATION

1. Resurface or replace flywheel. Surface must be smooth or premature clutch failure can occur.
REMEMBER: Machining the flywheel past the recommended .060" moves the pressure plate away from the transmission. In this event, install a fiber spacer (provided) on the input shaft between the clutch brake and the transmission. The release yoke in the bell housing may not align properly with the pressure plate release bearing housing. Linkage adjustment may be required during clutch setup. If resurfacing is required, while the flywheel is mounted to the crank shaft, verify correct flywheel dimensions as seen in Fig. 2 and Fig. 3.
2. Inspect and dial-indicate the mating surface of engine flywheel housing and clutch bell housing for alignment. Check flywheel run out. **CAUTION:** If misalignment is greater than the recommended limits, this will cause poor clutch release, rapid wear on transmission input shaft and destruction of the clutch disc. Excessive flywheel run out may cause severe vibration in vehicle drive line. (Fig. 5)

3. A new pilot bearing with a VITON® seal must be used. Before installing pilot bearing into flywheel, check freedom of movement on transmission input shaft.
4. Verify disc fits in flywheel bore (Fig. 1). Slide disc the length of the input shaft checking for twist and wear. Insert alignment shaft through bearing housing. Install rear disc (oriented correctly), center plate, and front disc (oriented correctly) on alignment shaft. Move clutch housing towards flywheel making sure cover fits into flywheel pilot.
5. Install the bolts (7/16 x 14unc x 2-1/4) that fasten the clutch housing on the flywheel. Tighten the bolts to the specified torque and the sequence specified by the manufacturer of the vehicle or transmission (Recommended 40-50 ft*lbs). Bolts should be Grade 5 or greater.
6. Remove caging fork from under the release bearing. Remove alignment shaft. Verify bearing distance from cover is 1/2" - 5/8" (Fig. 4). **NOTE: Any time the clutch is removed from the flywheel, the caging fork needs to be reinstalled. Failure to do so will cause adjusting arm to fall out of retainer stud. (Fig. 9) in Reset Procedure.**

Fig. 4

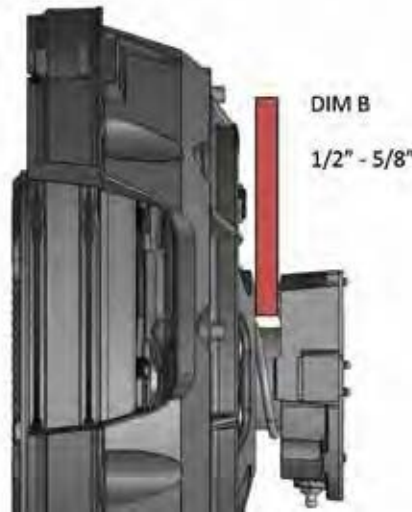

MEASURING ENGINE FLYWHEEL HOUSING AND FLYWHEEL

NOTE: Pilot Bearing must be replaced. Make sure all gauge contact surfaces are clean and dry.

CHECK THE FOLLOWING USING A DIAL INDICATOR:

Fig. 5



Flywheel Face Runout

Secure dial indicator base to flywheel housing face. Put gauge finger in contact with flywheel face near the outer edge. Rotate flywheel one revolution. Maximum runout is .008" (.20 mm).



Flywheel Housing I.D. Runout

Secure dial indicator base to crankshaft. Put gauge finger against flywheel housing pilot 1.0. Rotate flywheel one revolution. Maximum runout is .008 (.20 mm).



Pilot Bearing Bore Runout

Secure dial indicator base to flywheel housing face. Position gauge finger so that it contacts pilot bearing bore. Rotate flywheel one revolution. Maximum runout is .005" (.13 mm).



Flywheel Housing Face Runout

Secure dial indicator base to flywheel near the outer edge. Put gauge finger in contact with face of flywheel housing. Rotate flywheel one revolution. Maximum runout is .008"(.20 mm).

7. Reconnect lube hose attachment (For Hydraulic Linkage Systems).
8. Examine transmission input shaft and clutch release system components for wear and replace if necessary. (Fig. 6)
9. Install fiber spacer and replace clutch brake (fiber spacer not needed if over-sized clutch brake is used).
10. Be sure to properly lube the following components with NLGI grade 2 or 3 Lithium complex grease: Release Bearing, Yoke Fingers, Cross Shaft Bushings, and Linkage Pivot Points. Note: Applying enough grease to the release bearing until visible will extend the life of sleeve bushings and input shaft.

Fig. 6

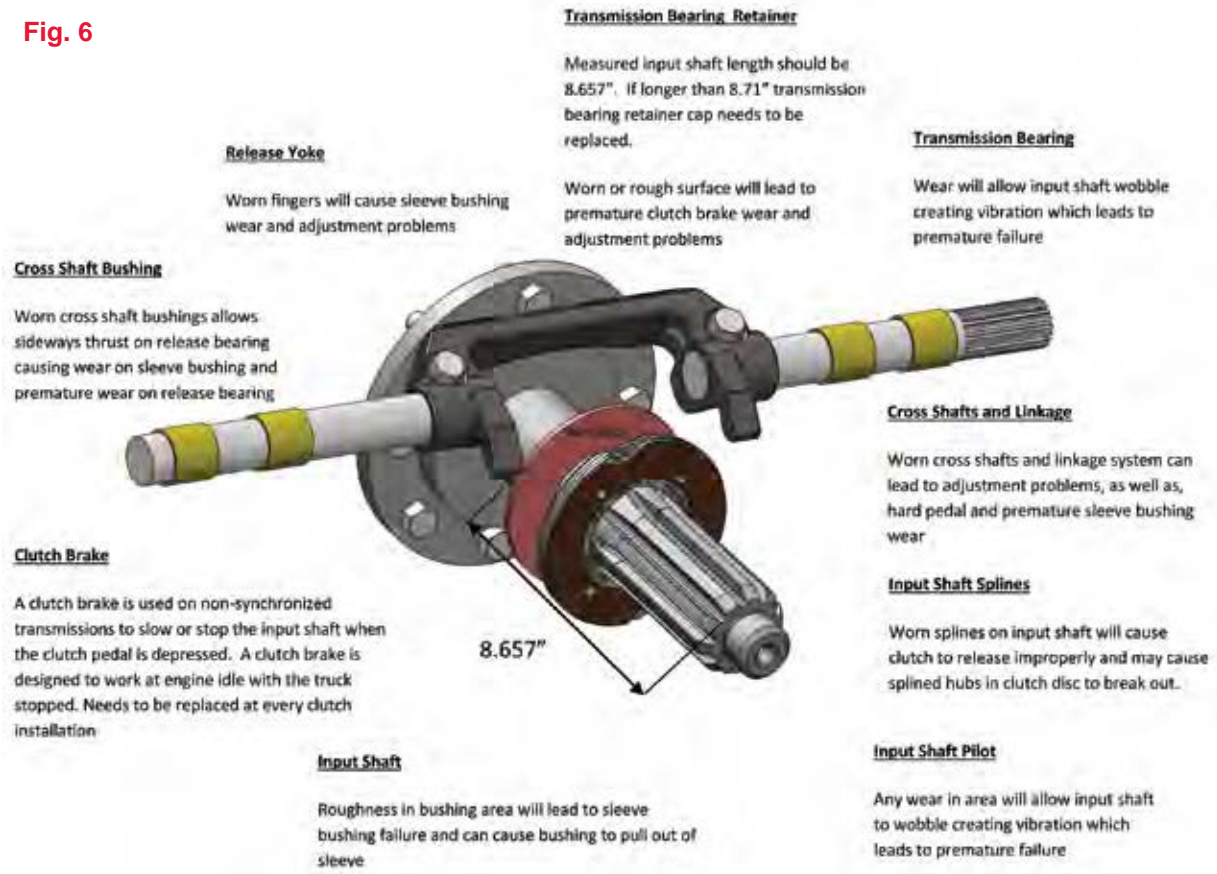

11. Using extreme caution, guide transmission through clutch cover, disc assemblies, and into pilot bearing rotating bell housing shaft so that release yoke fingers are clear of the pads on the release bearing assembly. (**Warning:** Transmission must not hang or be forced into the clutch. This can warp the clutch disc and prevent the clutch from releasing.) **NOTE: Do not add lube to input shaft splines!**
12. Start bell housing bolts and tighten progressively to the torque recommended by the vehicle manufacturer.
13. Install clutch linkage. See "Clutch Set Up Procedure".

CLUTCH SET UP PROCEDURE

NOTE: Clutches are adjusted at the factory to original equipment specifications and should require very little internal adjustment to achieve proper release and engagement. The clutch must not be adjusted to accommodate thin or worn flywheels, or worn linkage, yoke and/or cross shaft bushings, or to accommodate other drive train deficiencies. Adjustment for such purposes will either cause the clutch to not function properly or will cause early clutch failure and will be apparent on factory inspection of warranty claims, thereby voiding the manufacturer warranty.

STEP #1

After transmission installation, check the clearance between the yoke tips and wear pads on bearing housing for 1/8" clearance. This determines pedal free play (Mechanical Linkage Only). (Fig. 7)

Adjust the clutch linkage to increase or decrease the yoke-to-bearing clearance. **NEVER USE THE INTERNAL CLUTCH ADJUSTMENT FOR THIS PURPOSE.**

STEP #2

Check for proper clutch brake and bearing gap of 1/2" to 9/16". If the gap is too small verify DIM B (Fig. 4 or Fig. 7). If DIM B is correct and a fiber spacer or oversized clutch brake was installed, remove the fiber spacer and/or replace over-sized clutch brake with standard thickness clutch brake. **NOTE: If the gap is larger than 9/16" and DIM B is correct then one of the following conditions exists. Fiber spacer/over-sized clutch brake was not installed or you need to re-measure input shaft length as seen in (Fig. 6). DO NOT ADJUST THE CLUTCH!**

THIS DIMENSION IS CRITICAL. DO NOT VARY—EITHER OVER OR UNDER THESE DIMENSIONS—UNDER ANY CIRCUMSTANCES.

REMINDER: The bearing must move a minimum of 1/2" or clutch will not release. Eliminate lost motion before checking for 1/2" movement. Lost motion is generally caused by loose or worn linkage, or worn yoke or cross shaft bushings.

STEP #3

Verify the clutch brake squeeze by inserting .010 feeler gauge between bearing and clutch brake, then depress the pedal to end of stroke. The feeler gauge must be tightly clamped between the bearing and the clutch brake. This verifies the contact of the bearing to the clutch brake.

The clutch brake will be squeezed if the total pedal stroke slightly exceeds the movement required to move the yoke/fork 5/8" to 11/16" (the combined total of the 1/8" clearance between yoke tips and wear pads and the 1/2" - 9/16" brake squeeze gap). To optimize brake squeeze slowly let up on the pedal and check the pedal position at the moment the .010" feeler gauge can be removed. If the pedal is less than 1/2" or more than 1" from the floor when gauge can be removed, re-adjust the linkage.

IN THE EVENT THE BRAKE IS NOT BEING SQUEEZED, DO NOT CHANGE THE 1/2" - 9/16" GAP FOR THE CLUTCH BRAKE, OR THE 1/8" CLEARANCE FOR THE BEARING HOUSING—CONSULT THE VEHICLE MANUFACTURER SERVICE MANUAL.

In analyzing the reasons for the brake not being squeezed, other things to check for are:

- Worn linkage components or yoke and cross shaft bushings. If necessary, replace those components.
- Improper linkage assembly. Verify that linkage is assembled in the correct hole locations.
- Pedal stroke. To adjust raise the upper and/or lower the lower pedal stops.
- If the clutch is hydraulically assisted, make sure the slave and master cylinders are functioning properly.

NOTE: MAXIMUM BRAKE SQUEEZE (IN CAB OF TRUCK) SHOULD NOT EXCEED 1" FROM THE END OF PEDAL STROKE. IF IT DOES, IT CAN BE ADJUSTED BY:

- Changing pedal stops in cab to reduce total pedal stroke.
- Increasing 1/8" yoke-to-bearing setting to lower squeeze. (This will increase free-pedal travel.)

STEP #4

Installer should carefully verify that there is 1/2" - 5/8" gap between clutch cover and release bearing, 1/8" of free travel between yoke and wear pads (mechanical linkage only), and 1/2" - 9/16" gap between release bearing and clutch brake.

TROUBLESHOOTING AND DIAGNOSTICS

Bearing Position too large (Greater than 5/8")

- Disc in Backwards
- 5/16" flywheel dimension is too small and disc is hitting crank bolts (Fig. 3)
- Flywheel bore is smaller than 10" (Fig. 1)

Bearing Position too small (Less than 1/2")

- Flywheel not resurfaced
- Flywheel Clutch Pilot is more than 3/16" (Fig. 2)
- Forgot to install a disc
- NOTE:** If any of the previous situations occur, verify the adjuster arm is still inserted in stud (Fig. 9)

Bearing to Clutch Brake Gap is greater than 9/16"

- Verify Bearing Position is in spec between 1/2" - 5/8" (Fig. 7)
- Input shaft measurement is too long/excessive wear on transmission input bearing retainer (Fig. 6)
- Did not use Over-Sized clutch brake or fiber spacer
- Self-Adjust mechanism not working—See Reset Procedure

Bearing to Clutch Brake Gap is less than 1/2"

- Verify bearing position is in spec between 1/2" - 5/8" (Fig. 7)
- Used over-sized clutch brake instead of standard clutch brake
- Using fiber spacer and don't need it

Free Travel is out of spec (Mechanical Linkage Systems Only)

- Verify Bearing Position is in spec between 1/2" - 5/8" (Fig. 7)
- Verify Bearing to Brake Gap is in spec between 1/2" - 9/16" (Fig. 7)

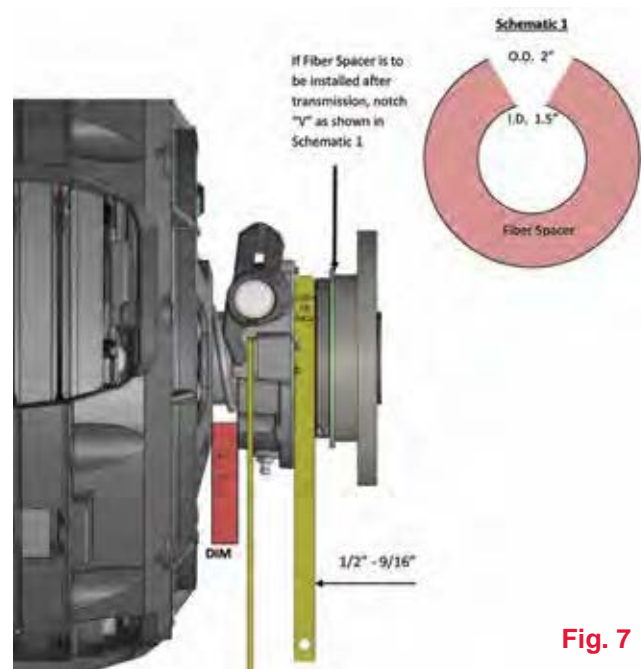
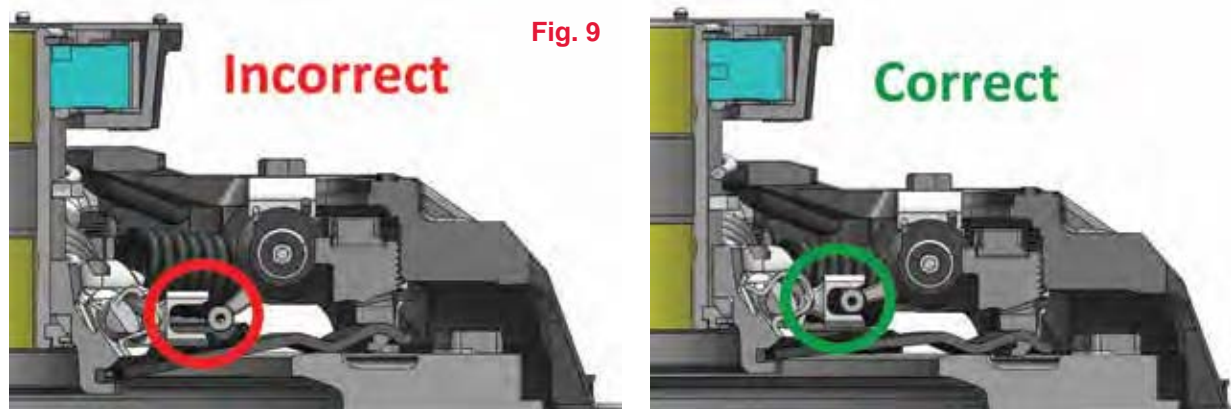
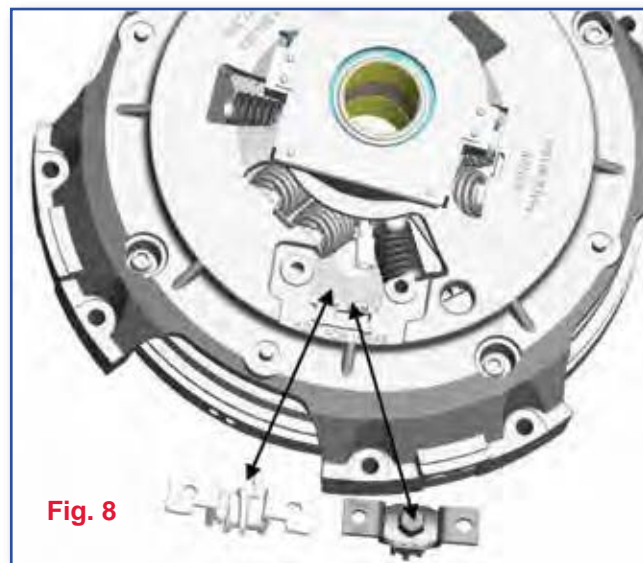

Fig. 7

Self-Adjust Reset Procedure

If for any reason the clutch needs to be reset or manually adjusted, follow the instructions below.

1. Remove self-adjusting mechanism (Fig. 8)
2. Disengage clutch
3. Install manual adjust mechanism (Fig. 8)
4. Manually adjust clutch to meet specs in set up procedure. (Fig. 7)
5. Reinstall self-adjusting mechanism. Ensure adjusting arm is properly seated in the retainer stud. (Fig. 9)
6. When reinstalling self-adjusting mechanism it may be necessary to manually ratchet the self-adjust mechanism so that the worm gear is seated properly in the adjusting ring teeth.



Maintenance Tips

IT IS IMPORTANT TO NOTE THAT THESE ARE GENERAL GUIDELINES ONLY AND THAT THE INSTALLER SHOULD ALWAYS REFER TO THE VEHICLE MAINTENANCE MANUAL FOR SPECIFIC DETAILS.

RECOMMENDED LUBE:

LINE HAUL - 50,000 MILES OR 3 MONTHS

VOCATIONAL - 250 HRS. OR 1 MONTH

- 1.** Only high temperature grease should be used for clutch bearing housing and linkage lubrication. Do not use chassis lubricant for clutch lubrication. Refer to the vehicle maintenance manual for lubricant specifications.
- 2.** Lubricate the clutch release bearing each time the chassis is lubricated.
- 3.** When lubricating the clutch, apply lubricant to each fitting on the clutch housing.
- 4.** Every point in the clutch linkage must be lubricated in addition to the clutch housing.
- 5.** Exercise caution in lubricating the bearing, as any excess lubricant will find its way onto the clutch facing.
- 6.** Manual adjust clutches must be adjusted once half the pedal free travel has been lost. Failure to do so will result in slippage and adjustment afterwards may not be effective.
- 7.** If the clutch is hydraulically assisted, make sure the slave and master cylinders are functioning properly.

Troubleshooting Clutch Operation

CLUTCH SLIPPING	
Probable Cause:	Correction:
1. Incorrect clutch adjustment	1. Re-adjust per installation instructions
2. Release mechanism binding	2. Check release mechanism and linkage. Lube if necessary.
3. Grease or oil on clutch facing	3. Replace with new clutch assembly. Find and repair cause of grease or oil contamination.
4. Worn clutch facings	4. Replace with new clutch assembly
5. Overloaded clutch – wrong application	5. Review application to ensure that proper clutch was installed.
6. Flywheel out of spec	6. Check flywheel for proper dimensions.
7. Driver foot resting on clutch pedal	7. Avoid using clutch pedal as a foot rest.
NOISY CLUTCH	
Probable Cause:	Correction:
1. Incorrect clutch adjustment	1. Re-adjust per instructions.
2. Clutch lacks lubricant or is damaged	2. Lubricate if a zerk fitting or replace clutch assembly.
3. Flywheel pilot bearing lacks lubricant or is damaged	3. Replace with new bearings.
4. Release yoke hitting cover assembly at full release position	4. Check yoke and linkage for wear. Ensure proper adjustment of yoke and linkage.
5. Worn linkage system	5. Check linkage, cross shaft, cross shaft bushings, and yoke.
6. Flywheel out of spec	6. Check flywheel for proper dimensions.
POOR CLUTCH RELEASE	
Probable Cause:	Correction:
1. Clutch adjustment not correct	1. Re-check adjustment per installation instructions.
2. Flywheel pilot bearing bound in flywheel or on input shaft	2. Replace pilot bearing and insure proper seating in flywheel and tolerance to input shaft.
3. Damaged clutch release bearing	3. Replace with new clutch assembly.
4. Clutch release shaft projecting through release yoke	4. Reposition release shaft so it does not project. Check bell housing bushings, cross shafts and release yoke for wear.
5. Release yoke hitting cover assembly at full release position	5. Check yoke and linkage for wear. Ensure proper adjustment of yoke and linkage.
6. Clutch brake worn, damaged, missing, or not fully squeezed	6. Replace worn, damaged, or missing clutch brake. Ensure proper clutch brake squeeze. Verify .010" using feeler gauge.
7. Intermediate plate sticking on drive lugs. (14" angle spring 2 plate assemblies only)	7. Check drive pins are 90° to flywheel surface and minimum .006" clearance between drive pins and center plate slots.
8. Pressure plate not retracting fully	8. Verify release bearing is being pulled a minimum of ½".
9. Worn splines on input shaft of transmission	9. Replace input shaft and check disc hubs for excess wear.
10. Flywheel out of spec	10. Check flywheel for proper dimensions.

Checklist

Before Removing Clutch

Step One: Visually Inspect Clutch System

- | | | | | |
|---|-----|--------------------------|----|--------------------------|
| 1. Is there any kind of contamination on the clutch? | Yes | <input type="checkbox"/> | No | <input type="checkbox"/> |
| 2. Are there any missing or broken pieces? | Yes | <input type="checkbox"/> | No | <input type="checkbox"/> |
| 3. Are the mounting bolts tight? | Yes | <input type="checkbox"/> | No | <input type="checkbox"/> |
| 4. Is there anything causing the linkage or fork to bind or drag? | Yes | <input type="checkbox"/> | No | <input type="checkbox"/> |

Step Two: Clutch Operation

- | | | | | |
|---|-----|--------------------------|----|--------------------------|
| 1. Is the clutch slipping? | Yes | <input type="checkbox"/> | No | <input type="checkbox"/> |
| 2. Does the clutch release? | Yes | <input type="checkbox"/> | No | <input type="checkbox"/> |
| 3. Does the clutch engage and disengage smoothly? | Yes | <input type="checkbox"/> | No | <input type="checkbox"/> |
| 4. Does the clutch make noise while engaged? | Yes | <input type="checkbox"/> | No | <input type="checkbox"/> |
| 5. Does the clutch make noise while disengaged? | Yes | <input type="checkbox"/> | No | <input type="checkbox"/> |

Step Three: Clutch Adjustment

- | | | | | | | Current Setting | Adjust. Made |
|---|-----|--------------------------|----|--------------------------|--|------------------------|---------------------|
| 1. Is the clutch adjusted properly? | Yes | <input type="checkbox"/> | No | <input type="checkbox"/> | | _____ | _____ |
| a) 1/2-5/8 inch under bearing to clutch | Yes | <input type="checkbox"/> | No | <input type="checkbox"/> | | _____ | _____ |
| b) 1/2-9/16 inch to clutch brake | Yes | <input type="checkbox"/> | No | <input type="checkbox"/> | | _____ | _____ |
| c) 1/8 inch free travel (mechanical linkage) | Yes | <input type="checkbox"/> | No | <input type="checkbox"/> | | | |
| 2. Is the clutch brake in the truck? | Yes | <input type="checkbox"/> | No | <input type="checkbox"/> | | | |
| a) Are tabs broken off? | Yes | <input type="checkbox"/> | No | <input type="checkbox"/> | | | |
| 3. Is a torque limiting brake installed? | Yes | <input type="checkbox"/> | No | <input type="checkbox"/> | | | |
| a) Can it be turned using channel locks or hands? | Yes | <input type="checkbox"/> | No | <input type="checkbox"/> | | | |
| 4. Does the linkage pull the bearing a minimum of 1/2 inch? | Yes | <input type="checkbox"/> | No | <input type="checkbox"/> | | | |
| 5. Is the clutch brake squeezed properly? | Yes | <input type="checkbox"/> | No | <input type="checkbox"/> | | | |
| a) Will a .010 feeler gauge between bearing and brake stay with the clutch depressed? | Yes | <input type="checkbox"/> | No | <input type="checkbox"/> | | _____ | _____ |

For Technical Assistance – Call 1-800-325-6138

Engine Horsepower & Torque Ratings

The data listed herein has been compiled from vehicle manufacturers and other reliable sources of information and is correct to the best of our knowledge. However, Ace Manufacturing & Parts Co. Cannot assume any responsibility for the accuracy of or possible errors in this information or in any other current or future informative bulletins of this nature.

IN SEQUENCE BY HORSEPOWER

NOTE: RATE VARIABLE HORSEPOWER ENGINES TO HIGHEST HORSEPOWER/TORQUE

ENGINE	HP	@ RPM	TORQUE	@ RPM
3116	195	2200	521	1560
6CTA-250	250	2200	720	1300
CAT 3066	260	1900	860	1350
CAT 3116	185	2600	520	1560
CAT 3116	215	2200	605	1560
CAT 3116	230	2200	660	1560
CAT 3116	250	2200	660	1560
CAT 3116	275	2200	750	1560
CAT 3116 (GM '91 UP)	215	2600	605	1560
CAT 3116 (GM MD)	275	2450	735	1560
CAT 3116 (GM-MD)	250	2600	650	1560
CAT 3116 (GM-MD)	300	2600	732	1560
CAT 3116 (HEUI)	170	2200	420	1560
CAT 3116 (MD)	170	2600	420	1560
CAT 3116 (MD)	200	2600	520	1560
CAT 3116G	185	2600	495	1560
CAT 3126	175	2400	420	1440
CAT 3126	190	2200	520	1440
CAT 3126	210	2200	605	1440
CAT 3126	230	2200	660	1440
CAT 3126	250	2200	800	1440
CAT 3126	275	2200	860	1440
CAT 3126	300	2200	860	1440
CAT 3176 ATMC	250	2100	975	1300
CAT 3176 ATMC	275	2100	1050	1200
CAT 3176 ATMC	300	2100	1150	1300
CAT 3176 ELEC	275	1800	1050	1100
CAT 3176 ELEC	275	1800	975	1100
CAT 3176 ELEC	300	1800	1050	1100
CAT 3176ATMC	325	2100	1225	1300
CAT 3176ATTMC	230	1800	975	1100
CAT 3176B	275	1800	1050	1100
CAT 3176B	300	1800	1050	1100
CAT 3176B	325	1800	1250	1200
CAT 3176B	350	1800	1350	1200
CAT 3208T (MD)	250	2600	640	1400
CAT 3208T(MD)	200	2000	620	1400
CAT 3306	245	2100	860	1350
CAT 3306	250	1800	860	1350
CAT 3306	270	2200	775	1400
CAT 3306C	300	1900	1150	1200

IN SEQUENCE BY HORSEPOWER
NOTE: RATE VARIABLE HORSEPOWER ENGINES TO HIGHEST HORSEPOWER/TORQUE

ENGINE	HP	@ RPM	TORQUE	@ RPM
CAT 3406	250	1600	1000	1200
CAT 3406	280	2100	1015	1200
CAT 3406	290	1800	1000	1200
CAT 3406	300	2100	1054	1200
CAT 3406	310	1800	1090	1200
CAT 3406	310	1800	1140	1100
CAT 3406	325	2100	1050	1200
CAT 3406	330	1600	1320	1200
CAT 3406	380	2100	1285	1200
CAT 3406	400	1900	1450	1250
CAT 3406	455	2100	1650	1200
CAT 3406	475	2100	1650	1750
CAT 3406	500	2100	1850	1200
CAT 3406	550	2100	1850	1200
CAT 3406 510	510	1600	1850	1200
CAT 3406B	350	2100	1320	1200
CAT 3406B	400	2100	1375	1260
CAT 3406B	425	2100	1450	1200
CAT 3406BEC	400	2100	1265	1300
CAT 3406BEC	400	1800	1375	1260
CAT 3406C	350	1800	1350	1200
CAT 3406C	425	1900	1650	1200
CAT 3406E	310	1800	1250	1200
CAT 3406E	330	1800	1350	1200
CAT 3406E	375	1800	1450	1200
CAT 3406E	410	1800	1450	1200
CAT 3406E	435	2100	1650	1200
CAT 3406E	475	2100	1750	1200
CAT 3406E	550	1800	1850	1200
CAT 3406E	600	2100	2050	1200
CAT 3406E MULTI TQ	310	1800	1150/1350	1200
CAT 3406E MULTI TQ	355	1800	1350/1450	1200
CAT 3406E MULTI TQ	375	1800	1450/1550	1200
CAT 3406E MULTI TQ	375/435	1800	1450/1550	1200
CAT 3406E(94)	355	1800	1450	1200
CAT 3406E(94)	375	1800	1550	1200
CAT 3406E(94)	410	1800	1550	1200
CAT 3406E(94)	435	1800	1650	1200
CAT 3406E(94)	475	1800	1750	1200
CAT 3406E(94)	500	1800	1850	1200
CAT 3408	420	1900	1460	1200
CAT 3408	450	2100	1460	1200
CAT 63306 CNG/LNG	235	2100	800	1200
CAT 63306 LPG (HD5)	250	2100	820	1200
CAT C-10	280	1800	1050	1100

IN SEQUENCE BY HORSEPOWER
NOTE: RATE VARIABLE HORSEPOWER ENGINES TO HIGHEST HORSEPOWER/TORQUE

ENGINE	HP	@ RPM	TORQUE	@ RPM
CAT C-10	305	2100	1150	1100
CAT C-10	325	2100	1250	1200
CAT C-10	335	1800	1350	1200
CAT C-10	350	1800	1350	1200
CAT C-10	370	1800	1350	1200
CAT C-10 MULTI	335/370	1800	1250/1350	1200
CAT C11	305	2100	1050	1200
CAT C11	335	2100	1250	2100
CAT C11	350	2100	1450	1200
CAT C11	370	2100	1450	1200
CAT C-12	355	1800	1350	1200
CAT C-12	360	2100	1350	1200
CAT C-12	380	1800	1450	1200
CAT C-12	390	2100	1450	1200
CAT C-12	410	2100	1550	1200
CAT C-12 MULTI TQ	355/410	1800	1350/1550	1200
CAT C-12 MULTI TQ	380/410	1800	1450/1550	1200
CAT C-12 RCVBUS	425	2100	1450	1200
CAT C13	305	2100	1150	1200
CAT C13	335	2100	1250	1200
CAT C13	350	2100	1550	1200
CAT C13	370	2100	1450	1200
CAT C13	380	2100	1450	1200
CAT C13	410	2100	1550	1200
CAT C13	430	2100	1650	1200
CAT C13	470	2100	1650	1200
CAT C13 MULTI TORQUE	410	2100	1450/1650	1200
CAT C13 MULTI TORQUE	430	2100	1550/1750	1200
CAT C13 MULTI TORQUE	470	2100	1550/1750	1200
CAT C15	435	2100	1650	
CAT C15	475	2100	1850	
CAT C15	500	2100	1850	
CAT C15	550	2100	1850	
CAT C15	600	2100	2050	
CAT C15	625	2100	2050	
CAT C15 MULTI TORQUE	435	2100	1550/1750	
CAT C15 MULTI TORQUE	475	2100	1650/1750	
CUM 1-10	260	1800	975	1200
CUM 1-10	270	2100	858	1400
CUM 1-10 310	310	1800	1150	1200
CUM 1-10 330E	330	1800	1250	1200
CUM 444	444	2100	1400	1500
CUM 4BT3.9	105	2500	260	1700
CUM 4BT3.9	105	2500	260	1700
CUM 4BTA3.9	120	2500	304	1700

IN SEQUENCE BY HORSEPOWER
NOTE: RATE VARIABLE HORSEPOWER ENGINES TO HIGHEST HORSEPOWER/TORQUE

ENGINE	HP	@ RPM	TORQUE	@ RPM
CUM 6BT55.9	160	2500	400	1700
CUM 6BTA5.9	190	2500	475	1600
CUM 6BTA5.9	210	2500	520	1600
CUM 6BTA5.9	230	2500	605	1600
CUM 6CT8.3	210	2200	605	1500
CUM 6CTA8.3	240	2200	645	1500
CUM 6CTA8.3	250	2200	728	1500
CUM FLEET 270	270	1600	1020	1100
CUM FLEET 285	285	1600	1150	1100
CUM FLT 300	300	1700	1150	1100
CUM FORM.240	240	1800	870	1300
CUM FORM 270	270	1800	1000	1300
CUM FORM 300	300	1800	1000	1300
CUM FORM 315	315	1800	1150	1300
CUM FORM 350(90)	350	1800	1175	1300
CUM FORM 350(90)	350	1800	1200	1300
CUM FORM 365(90)	365	1800	1325	1300
CUM FORM 400	400	1800	1250	1300
CUM FORM 450	450	1900	1420	1300
CUM FORM L10-240	240	1400	858	1300
CUM FORM VT-350	300	2100	860	1400
CUM ISX15 400	400	1100	1450	
CUM ISX15 425	425	1100	1650	
CUM ISX15 450	450	1100	1650	
CUM ISX15 485	485	1200	1850	
CUM ISX15 500	500	1200	1850	
CUM ISX15 525	525	1200	1850	
CUM ISX15 550	550	1200	2050	
CUM ISX15 600	600	1200	2050	
CUM KT 450	450	2100	1350	1500
CUM KT 525 (1983)	525	2100	1650	1300
CUM KTA 600 (1983)	600	2100	1650	1600
CUM L10	270	1900	858	1300
CUM L10	300	2100	950	1300
CUM L10 FORM	300	1900	950	1300
CUM L-10 STC 12CGA	260	1600	975	1200
CUM L-10 STC 12CGB	260	1700	975	1200
CUM L-10 STC 12CGC	280	1600	1050	1200
CUM L-10 STC 12CGD	280	1700	1050	1200
CUM L-10 STC 12CGG	310	1600	1150	1200
CUM L-10 STC 12CGH	300	1700	1150	1200
CUM L10-240	240	1900	870	1300
CUM M-11	400	1800	1450	1200
CUM M11 31 OE	310	2000	1150	1200
CUM M11 330E	330	2000	1350	1200

IN SEQUENCE BY HORSEPOWER
NOTE: RATE VARIABLE HORSEPOWER ENGINES TO HIGHEST HORSEPOWER/TORQUE

ENGINE	HP	@ RPM	TORQUE	@ RPM
CUM M11 370	370	2000	1350	1200
CUM M11ESP11	310-370	1800	1150	1350
CUM MII 280E CELECT	280	2000	1050	1200
CUM N14 12 CEC	370	1600	1400	1200
CUM N14 310	310	1800	1150	1350
CUM N14 330E	330	2100	1350	1200
CUM N14 350E	350	2100	1400	1200
CUM N14 370E	370	2100	1450	1200
CUM N14 410E	410	2100	1450	1200
CUM N14 435E	435	2100	1650	1200
CUM N14 435E	435	2100	1550	1200
CUM N14 469E	460	2100	1650	1200
CUM N14 500	500	1800	1750	1200
CUM N14 500E	500	1750	1650	1600
CUM N14 525	525	1800	1850	1200
CUM N14 CELECT 12 CDB	370	1600	1400	1100
CUM N14 CELECT 12 CDC	430	1700	1450	1100
CUM N14 CELECT 12 CDI	350	1600	1400	1100
CUM N14 CELECT 12 CDJ	460	1700	1550	1100
CUM N14 CELECT 12 CDK	310	1600	1250	1300
CUM N14 CELECT 12 CDR	310	1699	1450	1200
CUM N14 CELECT 12 CDS	330	1600	1350	1100
CUM N14 CELECT 12 CDS	370	1600	1550	1200
CUM N14 CELECT 12 CEN	410	1600	1450	1200
CUM N14 CELECT 12 CEP	430	1700	1550	1300
CUM N14 STC 12 CEE	410	1600	1450	1200
CUM N14 STC 12 CEG	410	1600	1450	1200
CUM N14 STC 12CEH	310	1600	1250	1100
CUM N14 STC 12CEJ	350	1600	1400	1100
CUM N14 STC 12CEK	350	1600	1350	1100
CUM N14EAPI	310-390	1800	1250	1450
CUM N14ESP3	400/460	1800	1450	1650
CUM NHTC-220	220	2100	644	1500
CUM NTC 315	315	1800	1150	1300
CUM NTC 350	350	2100	1120	1300
CUM NTC 365	365	1800	1320	1300
CUM NTC300	300	2100	1000	1300
CUM NTC350(90)	350	2100	1200	1300
CUM NTC400	400	2100	1250	1300
CUM NTC444XT	444	2100	1400	1500
CUM NTC-FORM400	400	1800	1325	1300
CUM PT 240	240	2100	900	1300
CUM SIGNATURE 600	600	2100	2050	1200
CUM STC 12 CEA	330	1600	1350	1100
CUM STC 12 CEB	330	1600	1350	1100

IN SEQUENCE BY HORSEPOWER
NOTE: RATE VARIABLE HORSEPOWER ENGINES TO HIGHEST HORSEPOWER/TORQUE

ENGINE	HP	@ RPM	TORQUE	@ RPM
DD 6-71T	275	2100	853	1200
DD 6-71T	300	2100	830	1400
DD 6-71TAC	270	2100	786	1200
DD 6V92TA	330	2100	963	1200
DD 6V92TA	350	2100	1020	1200
DD 8V71	304	2100	818	1400
DD 8V92TA	400	1800	1250	1200
DD 8V92TA	445	2100	1250	1300
DD 8V92TA	475	2100	1330	1300
DD 8V92TAC	440	2100	1250	1300
DD HAL	250	1800	970	1200
DD SERIES 60 11.1L-1L-6	330	1800	1150	1200
DD SERIES 50 8.5L-1 L-4	275	2100	890	1200
DD SERIES 50 8.5L-1L-4	300	1800/2100	1000	1200
DD SERIES 50 8.5L-1L-4L	315	1950/2100	1150	1200
DD SERIES 50 8.5L-1L-4	250	2100	780	1200
DD SERIES 55 12.1-1L-6	330	1800/2000	1250	1100
DD SERIES 55 12.1-1L-6	330/350	1800	1350	1100
DD SERIES 55 121-1L-6	350	1800/2000	1350	1100
DD SERIES 55 12L-1L-6	300	1800	1150	1100
DD SERIES 55 12L-1L-6	365	1800/2000	1450	1100
DD SERIES 55 12L-1L-6	365/400	1800	1450	1100
DD SERIES 60 11.1 L-1L-6	330/365	1800	1350	1200
DD SERIES 60 11.1-1L-6	350	1800	1250	1200
DD SERIES 60 11.1L-1L-6	300	1800	1150	1200
DD SERIES 60 11.1L-1L-6	330	1800	1150	1200
DD SERIES 60 11.1L-1L-6	350	2100	1250	1200
DD SERIES 60 11.1L-1L-6	365	1800	1350	1200
DD SERIES 60 11.1L-1L-6	300/330	1800	1150	1200
DD SERIES 60 11.1L-1L-6	330/350	1800	1250	1200
DD SERIES 60 12.7-1L-6	400	2100	1450	1200
DD SERIES 60 12.7-1L-6	370/400	1800	1450	1200
DD SERIES 60 12.7L-1 L-6	430	2100	1450	1200
DD SERIES 60 12.7L-1 L-6	500	1800	1550	1200
DD SERIES 60 12.7L-1 L-6	370/430	2100	1450	1200
DD SERIES 60 12.7L-1 L-6	430/470	2100	1550	1200
DD SERIES 60 12.7L-1L-6	370	2100	1450	1200
DD SERIES 60 12.7L-1L-6	470	1800	1550	1200
DD SERIES 92 12.11-V8	400	2100	1330	1200
DD SERIES 92 12.1L-V8	500	2100	1470	1200
DD SERIES 92 12.1L-V-8	450	2100	1425	1200
DD SERIES 92 9.051-V-6	350	2100	1020	1200
DD SERIES 92 9.05L-V6	300	2100	975	1200
FD-1060	160	2500	400	1600
FD-1060	175	2500	420	1600

IN SEQUENCE BY HORSEPOWER
NOTE: RATE VARIABLE HORSEPOWER ENGINES TO HIGHEST HORSEPOWER/TORQUE

ENGINE	HP	@ RPM	TORQUE	@ RPM
FD-1060	190	2500	475	1600
FD-1060	210	2300	520	1600
FD-1060	230	2300	605	1600
FD-1460	210	2200	605	1300
FD-1460	225	2200	660	1300
FD-1460	250	2000	800	1300
FD-1460	275	1800	860	1300
FORD 7.3 HI. ALT.	165	3000	325	1600
FORD 7.3L NATASP	185	3000	360	1400
FORD 7.3L TURBO	190	3000	395	1400
GM 6.5 L NATASP	160	3400	290	1700
GM 6.5 L TURBO	190	3400	385	1700
GM 6.5L NATASP	155	3600	275	1700
GM 6.5L TURBO	180	3400	360	1700
INTL 530	250	2200	800	1300
INTL 530	275	2000	950	1300
INTL 530	275	2200	860	1300
INTL 530	300	2000	1050	1300
INTL DT 408	210	2600	520	1800
INTL DT 408	230	2600	605	1800
INTL DT 466	195	2400	520	1600
INTL DT 466	210	2400	605	1600
INTL DT 466	275	2400	800	1600
INTL DT-408	175	2600	430	1800
INTL DT-408	190	2600	485	1800
INTL DT-466	230	2400	660	1600
INTL DT-466	250	2400	660	1600
INTL T444E	160	2600	400	1500
INTL T444E	175	2600	430	1500
INTL T444E	190	2600	485	1500
L10	280	1800	1050	1200
L-10 240/250PT	240-2100	250-2200	900	1300
L10 285PT	285	2200	1020	1300
L-10 FORM 240	240	1900	860	1300
M11 ESP1	280-330	1800	1050-1250	1200
M11-280E	280	2000	1050	1200
M11350E	350	1800	1350	1200
MACK E3-190 (MECH) CAT	190	2500	475	1300
MACK E3-220 (MECH)	220	2350	627	1400
MACK E6-250	250	2100	750	1500
MACK E6-275	275	2100	1020	1200
MACK E-6-300	300	1700	1112	1200
MACK E6-350	350	1800	1277	1250
MACK E7 325 VMAC	325	1800	1260	1250
MACK E7 350 VMAC	350	1800	1250	1250

IN SEQUENCE BY HORSEPOWER
NOTE: RATE VARIABLE HORSEPOWER ENGINES TO HIGHEST HORSEPOWER/TORQUE

ENGINE	HP	@ RPM	TORQUE	@ RPM
MACK E7 375 VMAC	375	1800	1460	1250
MACK E7 400	400	1800	1460	1250
MACK E7 427	427	1800	1560	1250
MACK E-7 454	454	1800	1560	1250
MACK E7-250 (MECH)	250	1950	975	1200
MACK E7-300 (MECH)	300	1950	1083	1200
MACK E7-300(V MAC)	300	1700	1160	1200
MACK E7-350	350	1800	1277	1250
MACK E9	550	2100	1660	1300
MACK E9 450	450	1900	1495	1300
MACK E9 500	500	1900	1660	1300
MACK EM6-250	250	2100	940	1260
MACK EM6-250L	250	1750	1190	1020
MACK EM6-275	275	2100	1038	1260
MACK EM6-275L	275	1750	1305	1020
MACK EM6-300L	300	1750	1425	1020
MACK EM7-250 (MECH)	250	1750	1190	1020
MACK EM7-250L	250	1750	1190	1020
MACK EM7-275 (MECH)	275	1750	1305	1250
MACK EM7-275 (V MAC)	275	1750	1305	1250
MACK EM7-300 (MECH)	300	1750	1425	1020
MACK EM7-300VMAC	300	1750	1425	1020
MBE 4000-350	350	1900	1350	
MBE 4000-350/370	350/370	1900	1350	
MBE 4000-370	370	1900	1450	
MBE 4000-410	410	1900	1550	
MBE 4000-410/435	410/435	1900	1550	
MBE 4000-410/450	410/450	1900	1550	
MBE 4000-435	435	1900	1550	
MBE 4000-450	450	1900	1550	
MX-13	380	1000	1450	
MX-13	405	1000	1750	
MX-13	430	1000	1750	
MX-13	455	1000	1750	
MX-13	485	1000	1650	
MX-13	500	1000	1850	
N 14ESPII	350-390	1800	1350	1500
NTC 475	475	2100	1430	1400
VOLVO 260E/300AE	260	2100	800	1080
VOLVO 280G/330BE	280	1700	925	1200
VOLVO 300A/360CE	300	2100	925	1200
VOLVO 300CC/410DE	300	2100	955	1200
VOLVO 310B	310	1900	985	1200



Manufacturing & Parts Co.
American Made Clutches Since 1967

Our 118,000 square foot manufacturing and distribution facility is located 60 miles southwest of St. Louis in Sullivan, Missouri.

Ace has been providing the highest quality clutches, clutch parts and assemblies to the heavy duty industry for over 50 years.

SALES SUPPORT DIRECTORY

NAME	TITLE	PHONE	E-MAIL
Jerry Cone	Sales Manager	Cell: (859) 300-4476	jccone@ace-mfg.com
Chuck Peoples	Outside Sales	Cell: (636) 303-8075	cpeoples2@ace-mfg.com
James Lawson	Outside Sales	Cell: (816) 305-4739	jlawson@ace-mfg.com
Steve Russom	Customer Satisfaction Specialist	(573) 468-1720	srussom@ace-mfg.com
Dwayne Hoke	Technical Support Specialist	(573) 468-1722	dhoke@ace-mfg.com
Barb Reed	Customer Satisfaction Coordinator	(573) 468-1745	breed@ace-mfg.com
Tricha Cassidy	Customer Satisfaction Specialist	(573) 468-1735	tcassidy@ace-mfg.com

For high quality,
low cost, American made
E-Z RIDER® Clutches,
CALL: 1-800-325-6138
or visit our website:
www.ace-mfg.com

SCAN WITH YOUR
SMARTPHONE



AN INNOVATIVE LEADER IN CLUTCH TECHNOLOGY



ACE

Manufacturing & Parts Co.

American Made Clutches Since 1967

300 Ramsey Street
Sullivan, MO 63080
U.S.A.

Toll Free: 800-325-6138
Fax: 573-468-5584
www.ace-mfg.com