

Important User Information

Read this document and the documents listed in the additional resources section about installation, configuration, and operation of this equipment before you install, configure, operate, or maintain this product. Users are required to familiarize themselves with installation and wiring instructions in addition to requirements of all applicable codes, laws, and standards.

Activities including installation, adjustments, putting into service, use, assembly, disassembly, and maintenance are required to be carried out by suitably trained personnel in accordance with applicable code of practice.

If this equipment is used in a manner not specified by the manufacturer, the protection provided by the equipment may be impaired.

In no event will Rockwell Automation, Inc. be responsible or liable for indirect or consequential damages resulting from the use or application of this equipment.

The examples and diagrams in this manual are included solely for illustrative purposes. Because of the many variables and requirements associated with any particular installation, Rockwell Automation, Inc. cannot assume responsibility or liability for actual use based on the examples and diagrams.

No patent liability is assumed by Rockwell Automation, Inc. with respect to use of information, circuits, equipment, or software described in this manual.

Reproduction of the contents of this manual, in whole or in part, without written permission of Rockwell Automation, Inc., is prohibited.

Throughout this manual, when necessary, we use notes to make you aware of safety considerations.



WARNING: Identifies information about practices or circumstances that can cause an explosion in a hazardous environment, which may lead to personal injury or death, property damage, or economic loss.



ATTENTION: Identifies information about practices or circumstances that can lead to personal injury or death, property damage, or economic loss. Attentions help you identify a hazard, avoid a hazard, and recognize the consequence.

IMPORTANT

Identifies information that is critical for successful application and understanding of the product.

Labels may also be on or inside the equipment to provide specific precautions.



SHOCK HAZARD: Labels may be on or inside the equipment, for example, a drive or motor, to alert people that dangerous voltage may be present.



BURN HAZARD: Labels may be on or inside the equipment, for example, a drive or motor, to alert people that surfaces may reach dangerous temperatures.



ARC FLASH HAZARD: Labels may be on or inside the equipment, for example, a motor control center, to alert people to potential Arc Flash. Arc Flash will cause severe injury or death. Wear proper Personal Protective Equipment (PPE). Follow ALL Regulatory requirements for safe work practices and for Personal Protective Equipment (PPE).

	Preface	5
	About This Publication.....	5
	Terminology.....	5
	Additional Resources.....	5
	 Chapter 1	
Installation	Before You Begin.....	8
	What You Need.....	8
	Follow These Steps.....	8
	Assemble the E300 Relay.....	9
	Wire the E300 Relay.....	13
	Establish the IP Address	15
	E300 Configuration via Rotary Dial Addressing:.....	15
	E300 Configuration via the BOOTP/ DHCP Utility:.....	16
	Downloading the Electronic Data Sheet (EDS) File:.....	17
	 Chapter 2	
Configuration and Communication with a Logix™ Controller	Before You Begin.....	19
	What You Need.....	19
	Follow These Steps.....	19
	Add an E300 Overload Relay to a Studio 5000™ or RSLogix 5000 Project	19
	Add E300 Device Profile	20
	Upload Parameters	21
	Set the Operating Mode.....	22
	Set the FLA	24
	Download the Project to the Logix Controller	25
	Use Output Tags to Control the Motor	26
	 Chapter 3	
Device Configuration Using the Diagnostic Station	Before You Begin.....	29
	What You Need.....	29
	Follow These Steps.....	29
	Edit Configuration Preset (Parameter 164).....	29
	Edit Full Load Amps (Parameter 171).....	30
	 Chapter 4	
Device Configuration Using the Web Server	Before You Begin.....	31
	What You Need.....	31
	Follow These Steps.....	31
	Enabling the E300 Relay Web Server.....	31
	Select the Operating Mode with ConfigPreset (Parameter 164) ...	33
	Set Motor FLA Using FLASetting (Parameter 171)	34

E300 Relay Operating Mode Summary	Appendix A	37
	Index	41

About This Publication

This manual describes the minimum steps required to install and configure the E300™ Electronic Overload Relay. More detailed information about the E300 Electronic Overload Relay is available in the E300 Electronic Overload Relay User Manual, publication [193-UM015](#).

The beginning of each chapter contains the following information. Read these sections carefully before you begin work in each chapter:

- **Before You Begin** - The chapters in this quick start do not have to be completed in the order in which they appear. However, this section defines the minimum amount of preparation that is required before completing the current chapter.
- **What You Need** - This section lists the tools that are required to complete the steps in the current chapter, including, but not limited to, hardware and software.
- **Follow These Steps** - This section illustrates the steps in the current chapter and identifies the steps that are required to complete the examples.

Terminology

Throughout this manual, we refer to the E300™ electronic overload relay as “the E300 relay”. This term is used interchangeably with “E300 electronic overload relay”; they are synonymous.

Additional Resources

These documents contain additional information concerning related products from Rockwell Automation.

Resource	Description
E300 Electronic Overload Relay Selection Guide, publication 193-SG010	Provides product selection information about the E300 overload relay.
E300 Electronic Overload Relay User Manual, publication 193-UM015	Provides complete user information about the E300 overload relay.
DeviceLogix™ System User Manual, publication RA-UM003B	Provides complete information about the DeviceLogix editor and its functions.
Industrial Automation Wiring and Grounding Guidelines, publication 1770-4.1	Provides general guidelines for installing a Rockwell Automation industrial system.
Product Certifications website, http://www.rockwellautomation.com/global/certification/overview.page	Provides declarations of conformity, certificates, and other certification details.

You can view or download publications at <http://www.rockwellautomation.com/global/literature-library/overview.page>. To order paper copies of technical documentation, contact your local Allen-Bradley distributor or Rockwell Automation sales representative.

Notes:

Installation

This chapter explains how to assemble the three module types of the E300 electronic overload relay, wire the relay, and set the relay IP address.

Three modules comprise the E300 relay. All three modules are required to make a functional overload relay. You can customize each of the three with accessories to tailor the electronic motor overload for the exact needs of your application. [Figure 1](#) through [Figure 3](#) show the three types of E300 relay modules.

Figure 1 - Sensing Module

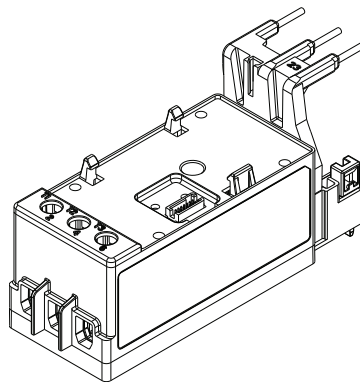

Figure 2 - Control Module

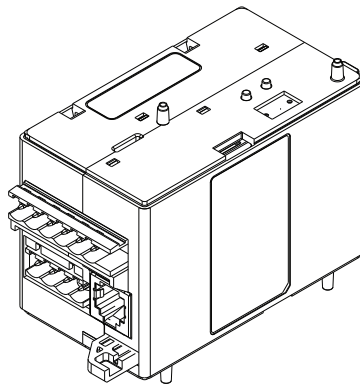
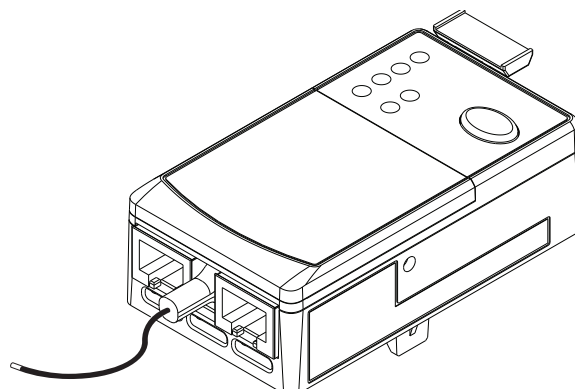

Figure 3 - Communication Module



Before You Begin

Familiarize yourself with installation and wiring instructions in addition to requirements of all applicable codes, laws, and standards.

Activities including installation, adjustments, putting into service, use, assembly, disassembly, and maintenance are required to be carried out by suitably trained personnel in accordance with applicable code of practice.

What You Need

- E300 relay control, communication, and sensing modules
- Any additional modules required (operator station, contactor, etc.)
- Wiring diagram(s)
- Thin flathead screwdriver
- Wire for I/O terminals, #12...24 AWG
- Standard industrial grade Ethernet cable

Follow These Steps

Complete the following steps to install the E300 relay. When you have finished, you will be ready to communicate with a Logix controller, use the diagnostic station and web server to control, protect, and troubleshoot a motor.



Assemble the E300 Relay

Complete the following steps to assemble the E300 relay. When you have finished, you will be ready to wire and configure the device.

IMPORTANT Take caution while assembling each module and add-on component. Small I/O pins can bend and/or break, which causes a module service error once the device is configured.

1. Connect the E300 relay control module to the E300 relay sensing module.

Be sure to secure this connection by pushing in the tab on the right side of the control module.

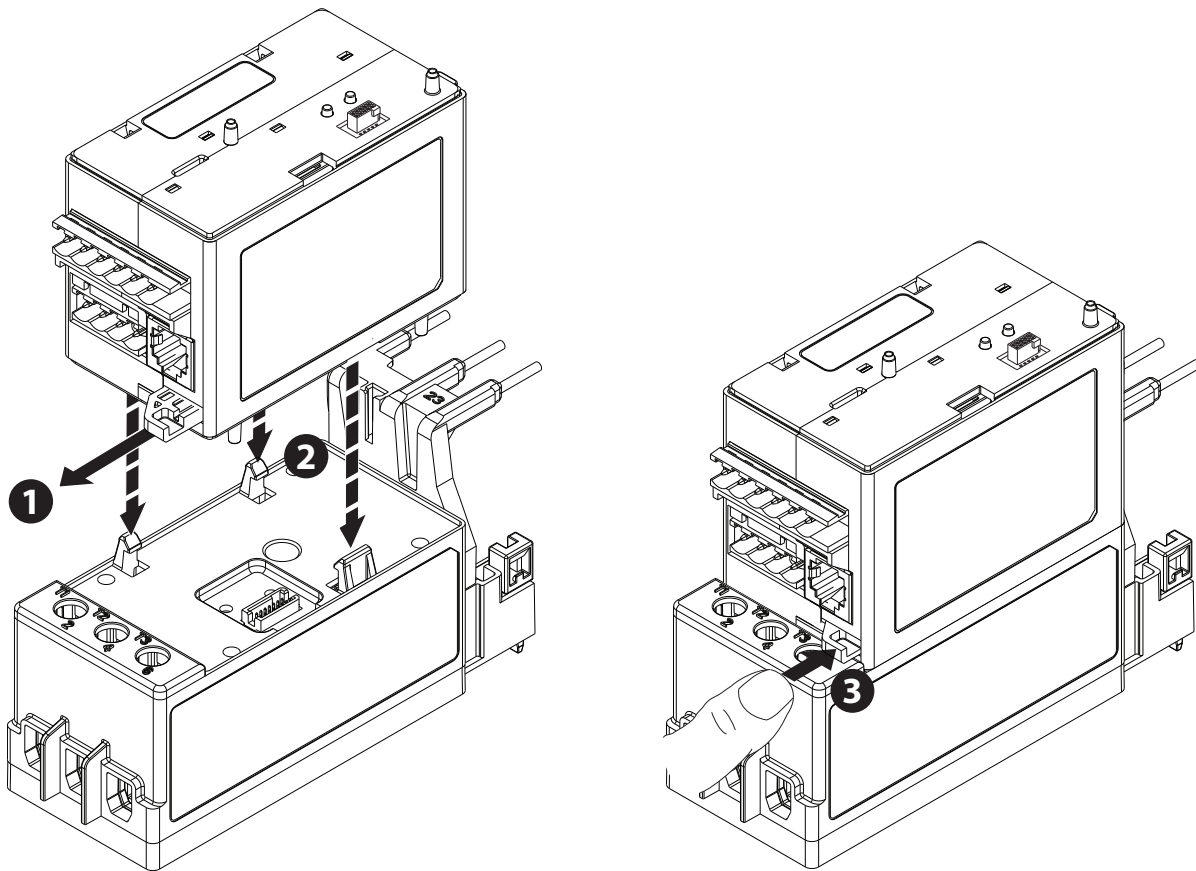

2. Connect the E300 relay communication module to the E300 relay control module.

Be sure to secure this connection by pushing in the tab shown on the left side of the control module.

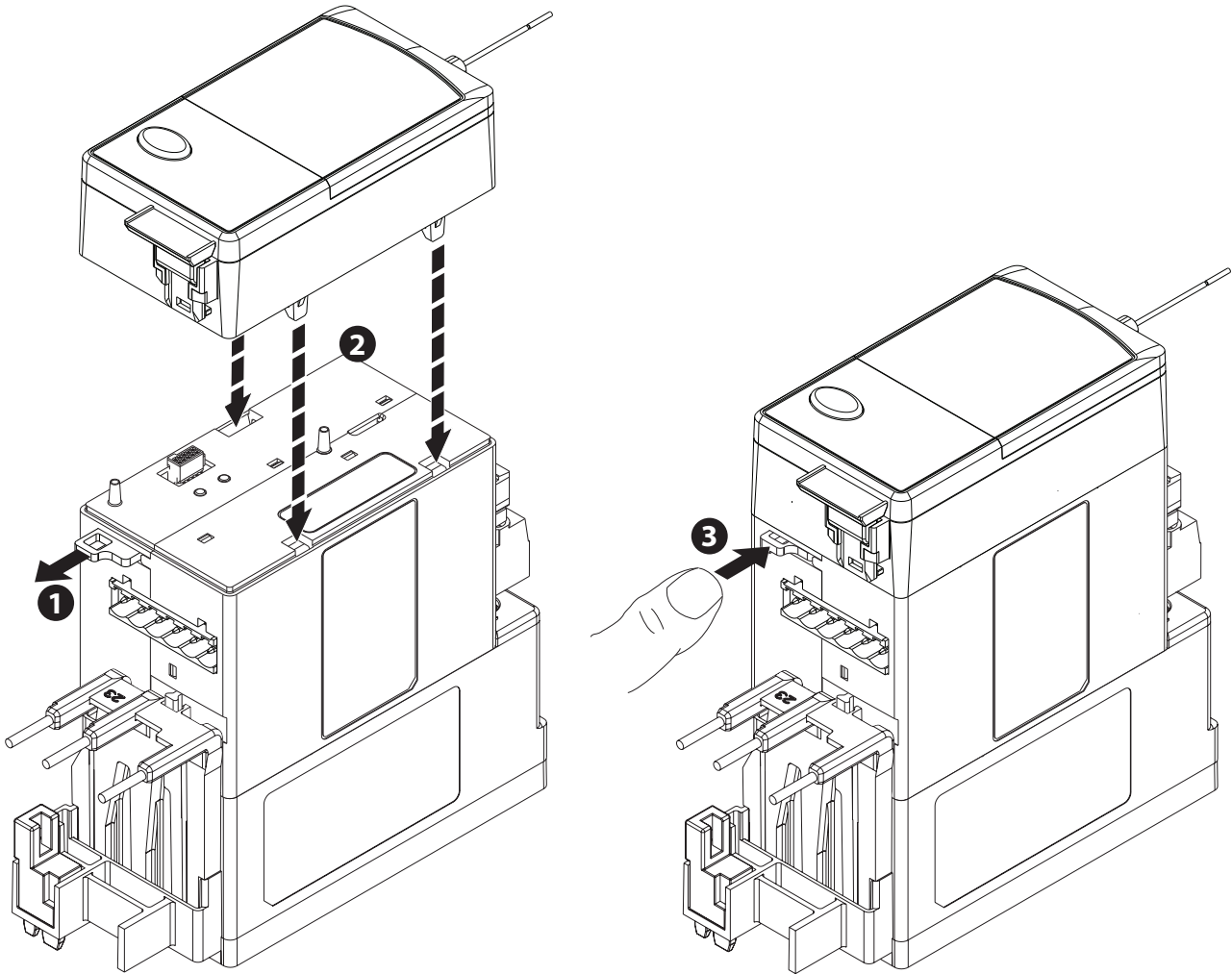

3. Install the I/O connectors.

Two of the I/O connectors attach to the bottom of the control modules. The third connector attaches to the top of the control module.

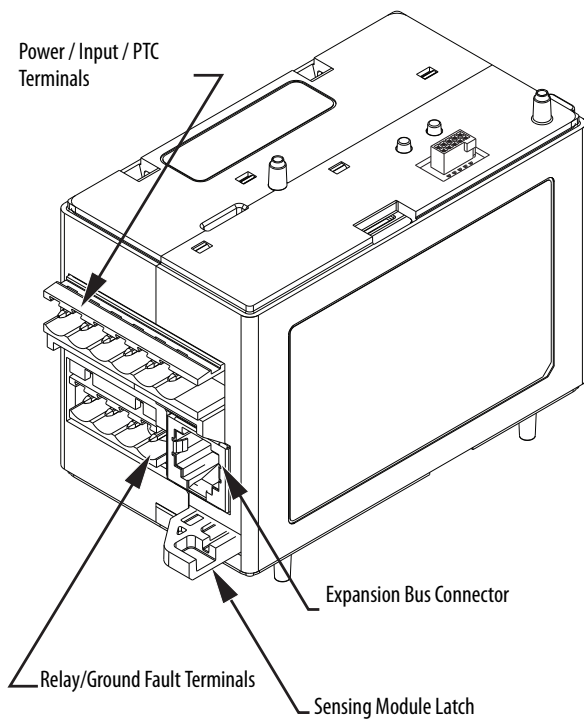

You have completed the assembly of the E300 Overload Relay.

- Attach any add-on modules that you require.

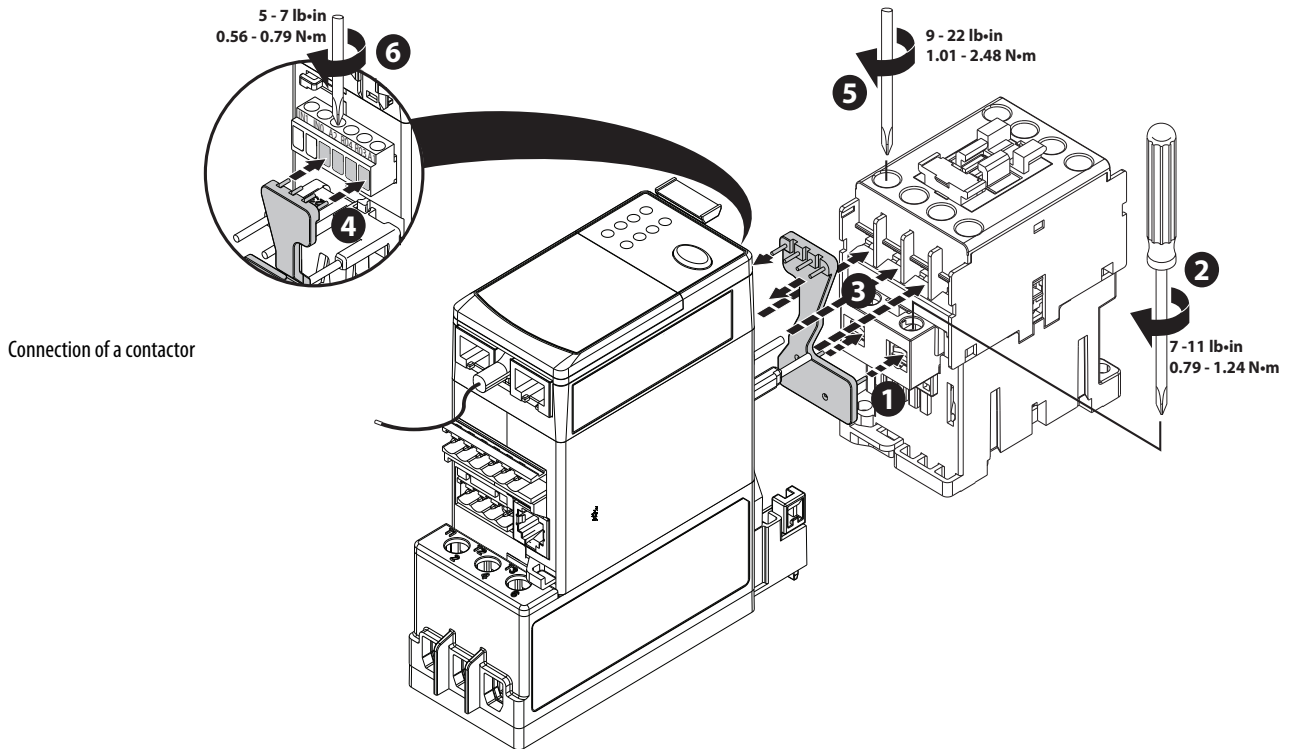
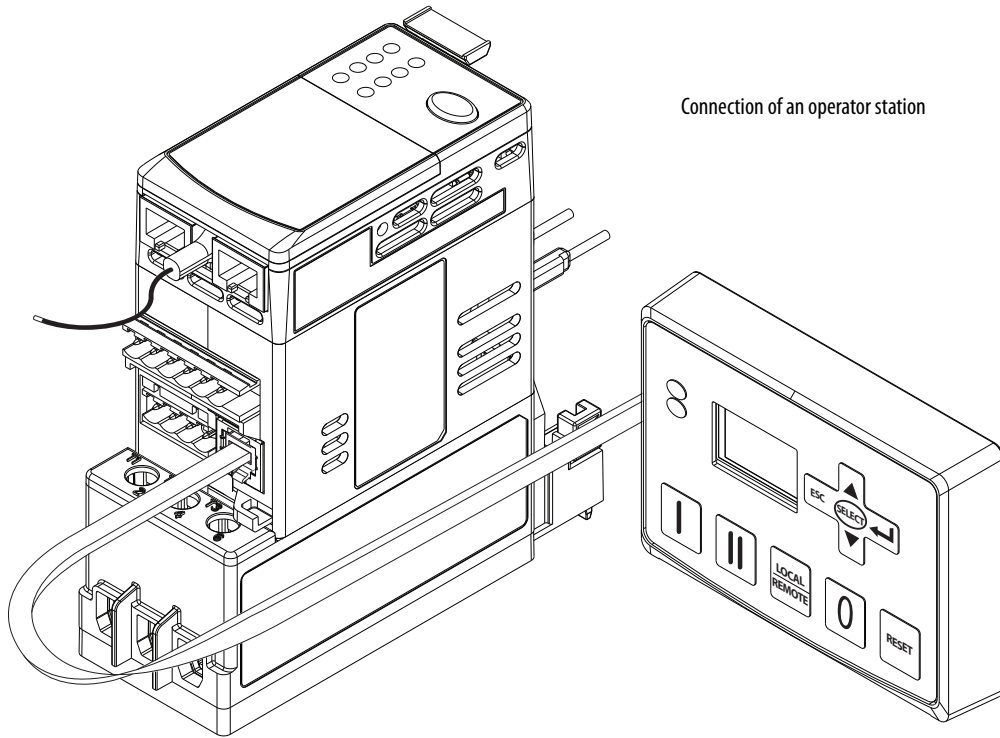

Wire the E300 Relay

Complete the device wiring according to the appropriate wiring diagrams for your application. You can wire the E300 relay in multiple ways, depending on the accessories, add-on modules, application requirements, etc. The wiring diagrams in this section are for illustrative purposes only.

For the E300 Electronic Overload Relay to function properly and protect your motor, it needs a control voltage (24V DC, 120V AC, 240V AC). Connect the control voltage to the device by attaching wires to the A1 (positive) and A2 (negative) terminals, which are located on the bottom of the control module of the E300 relay. [Figure 4](#) shows this configuration.

Figure 4 - Control Module Wiring

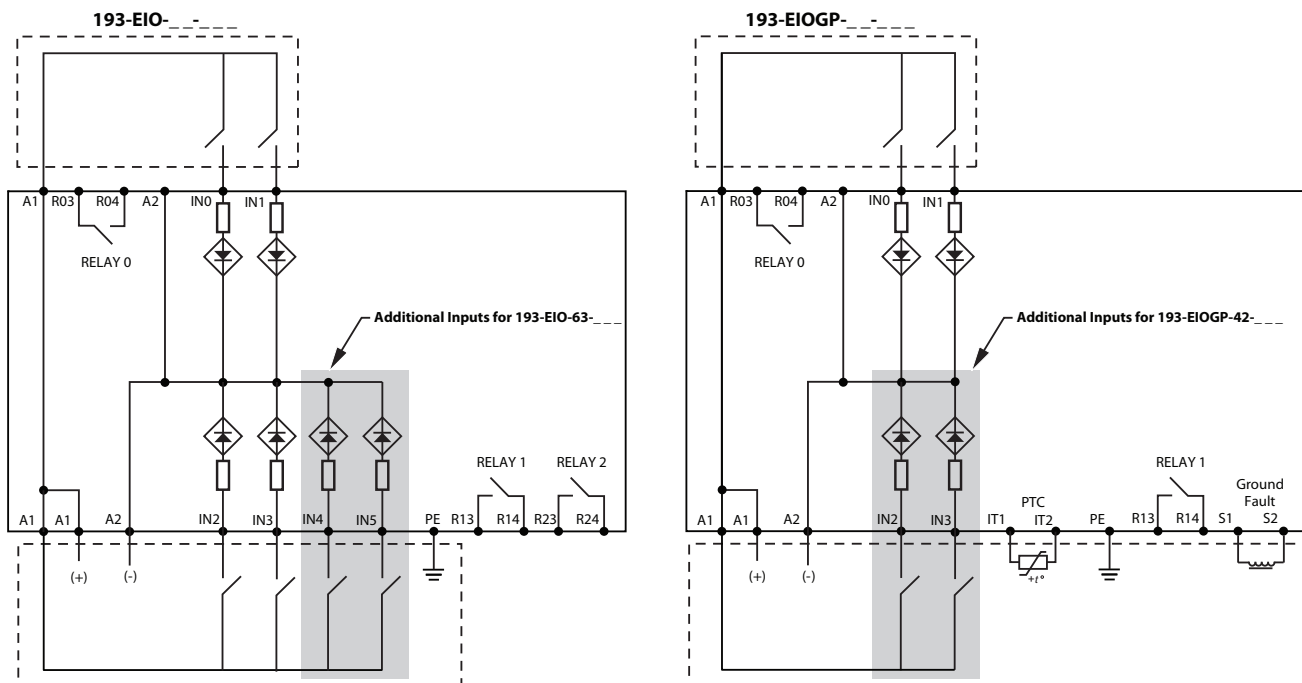

The E300 overload relay typically is wired in one of two different motor connections: a three-phase, direct-on-line (DOL), and a single-phase, full-voltage connection. Figure 5 shows these connections.

Figure 5 - E300 DOL and Single-Phase Full-voltage Connections (NEMA Nomenclature)

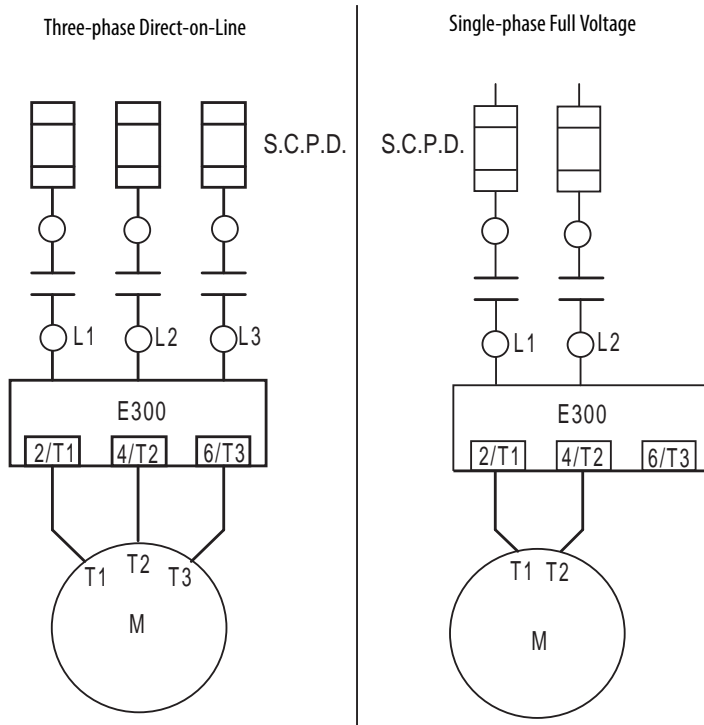
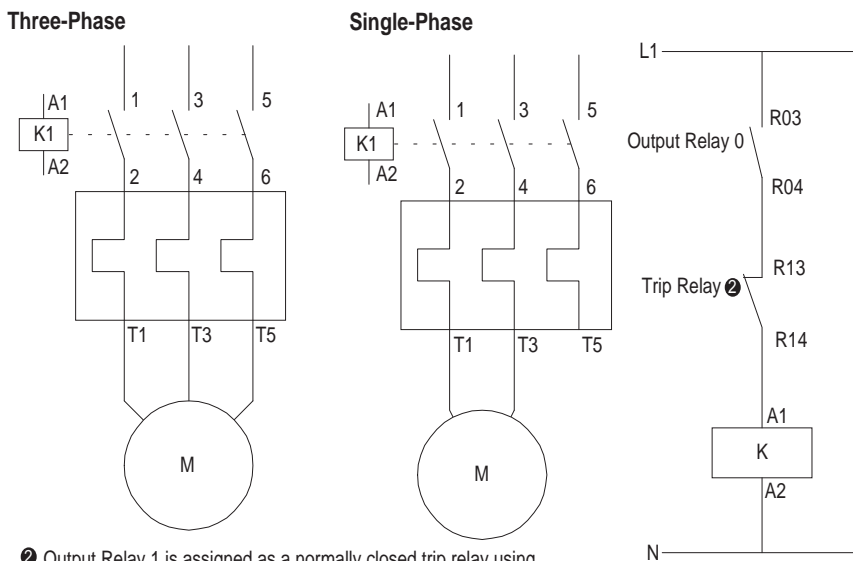

Figure 6 - E300 DOL and Single-Phase Full-voltage Connections (CENELEC Nomenclature)



② Output Relay 1 is assigned as a normally closed trip relay using Parameter 203 (Output 1 Assignment).

Establish the IP Address

You may use one of two methods to configure the IP address for the E300 relay: configuring via the rotary dial addressing, or by using the BOOTP/DHCP utility. After the IP address is configured, you will download and install the Electronic Data Sheet (EDS) for RSLinx™ Classic and RSLinx Enterprise connectivity software.

E300 Configuration via Rotary Dial Addressing:

The E300 Overload Relay EtherNet/IP Communication Module has three node address selection switches that allow you to select the last octet for the IP address 192.168.1.xxx. When you set the node address selection switches to a value greater than 255 (excluding 888), the IP address is set to DHCP Enabled or programmed for a static IP address.

Figure 7 - E300 Relay Node Addressing

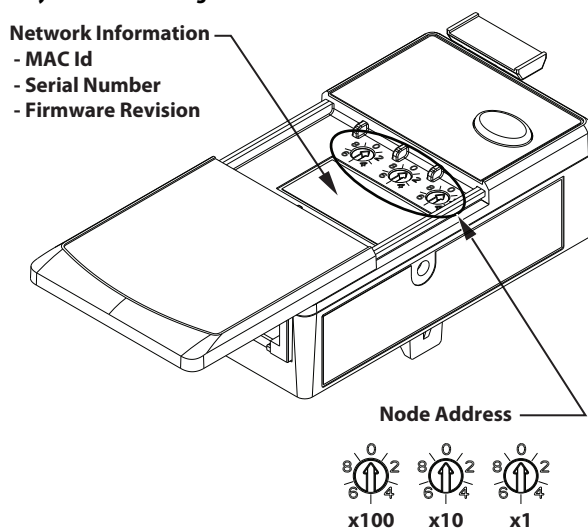

Node Address	Function
001 - 254	Set IP Address to 192.168.1.xxx
255 - 887 889 - 999	Set IP Address via DHCP or use static IP Address
888	Reset to factory defaults
000	Administration mode

1. Verify that the E300 Relay is fully powered, then turn the three dials to your selected IP address.
2. Once dials are in place, cycle power to the E300 Relay.

For example, when the left dial is set to 0, the middle is set to 0, and the right dial is set to 6, the resulting IP address is: **192.168.1.006** or **192.168.1.6**.

IMPORTANT A power cycle is required for any rotary dial changes to the E300 Relay to take effect.

E300 Configuration via the BOOTP/ DHCP Utility:

By default, the E300 relay EtherNet/IP Communication Module is DHCP Enabled. The BOOTP/DHCP utility is a standalone program that is included when you install RSLinx Classic software.

IMPORTANT Before starting the BOOTP/DHCP utility, verify the hardware MAC ID, which is printed on the front of the E300 Relay Communication Module. The MAC ID has a format similar to: 00-0b-db-14-55- 35.

To assign an IP address to the E300 relay via the BOOTP/DHCP utility, perform the following procedure

1. Execute the BOOTP/DHCP software and choose Tool, then select Network Settings.
2. Type the subnet mask, gateway address, primary/secondary server addresses, and domain name in their respective fields. Click OK

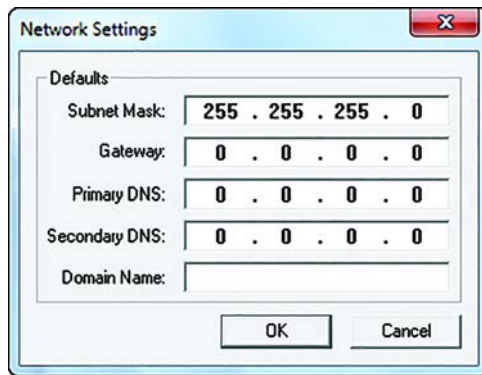

3. Double-click the MAC address of the E300 module that you want to configure. It may take a few seconds for your E300 relay to show up in the Request History.

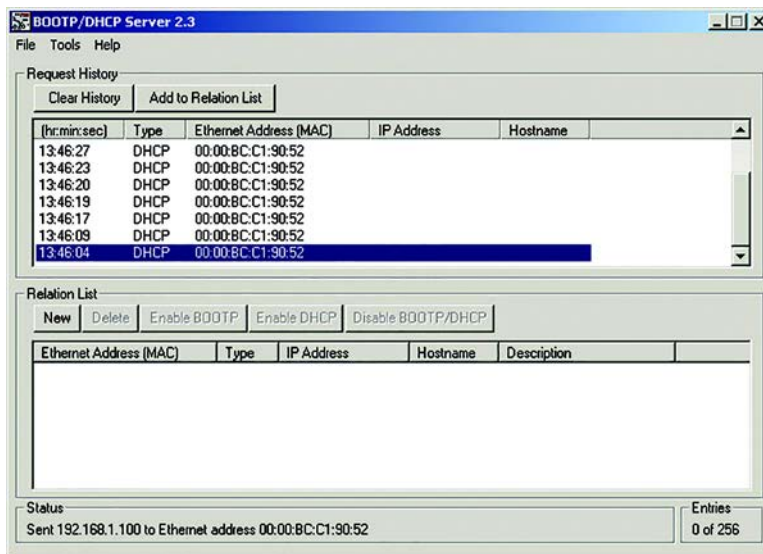

4. The New Entry window appears with the Ethernet Address (MAC). Type the IP address. Select OK.

The image shows a 'New Entry' dialog box with the following fields and values:

- Ethernet Address (MAC): 00:00:BC:C1:90:52
- IP Address: 192 . 168 . 1 . 100
- Hostname: (empty)
- Description: (empty)

Buttons: OK, Cancel

5. Cycle power to the E300 relay.
6. Once your E300 is powered up, verify that the proper IP address has been assigned, select the module in the Relation List panel, and click Disable BOOTP/DHCP.

After completing either one of the above methods, your E300 Electronic Overload Relay will be configured and connected to your network. The next step to communicating with the E300 is to download its EDS file. The following steps will guide you through the process.

Downloading the Electronic Data Sheet (EDS) File:

The EDS file for the E300 relay EtherNet/IP communication module is embedded within the module. Using RSLinx™ Classic, you can install the proper EDS file for the E300 relay using the following steps:

1. Open RSLinx Classic and browse the EtherNet/IP network that has the E300 relay. It is identified with a yellow question mark. Right click on the unrecognized device and select Upload EDS File from Device.
2. Using the EDS Wizard, install the embedded E300 relay EtherNet/IP Communication Module EDS file.
3. When finished, RSLinx Classic recognizes the newly registered E300 relay EtherNet/IP Communication Module. The yellow question mark should have disappeared.

Now your E300 relay is configured within your network.

Notes:

Configuration and Communication with a Logix™ Controller

You can manually add a preconfigured E300 relay offline to any Logix processor, or you can manually add a preconfigured E300 relay online to a ControlLogix™ processor. You can perform an upload command to retain all of the E300 relay's configuration settings.

Before You Begin

To complete this chapter, you must have completed the requirements in [Appendix 1](#).

What You Need

- An E300 relay that is set up and connected to a communication network

Follow These Steps

In this chapter, you will perform the following steps to set up communication between a Logix controller and the E300 relay.

1. Add the E300 relay device profile to the project
2. Upload the configuration settings of the preprogrammed E300 relay to the project
3. Set the E300 relay operation mode
4. Set the full-load current (FLA)
5. Download the project to the Logix controller
6. Use an Output tag to control the motor

Add an E300 Overload Relay to a Studio 5000™ or RSLogix 5000 Project

Follow these steps to manually add an E300 relay and retain its configuration settings with a new or existing RSLogix 5000 or Studio 5000 project.

Add E300 Device Profile

1. Create a new or open an existing RSLogix 5000 or Studio 5000 project and verify that the Logix controller is offline. Make sure that your project communication path is correct and the software is communicating with your controller.

IMPORTANT To choose the correct path, select RSWho which is the button next to the path's drop down menu, and navigate to your Logix controller. The Logix controller used for this demonstration has an IP address of 192.168.1.2.

2. Right click on the Ethernet tree of the EtherNet/IP scanner and select *New Module*.

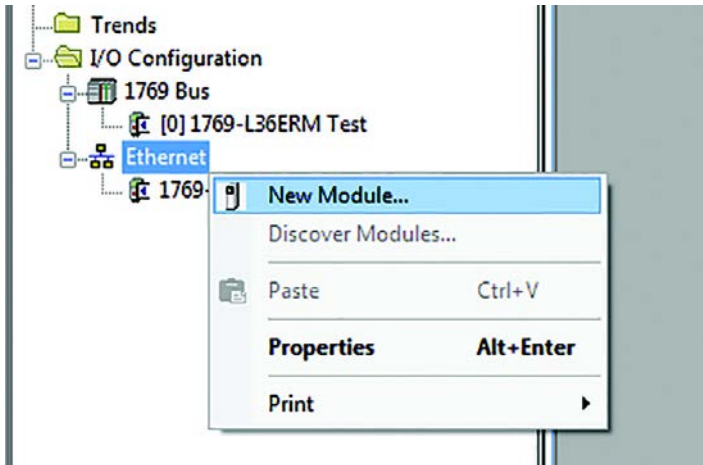

3. Search for an E300 relay by typing *E300* in the search field, select the *193-ECM-ETR Electronic Overload Relay, 2-Port* device profile, and click *Create*.

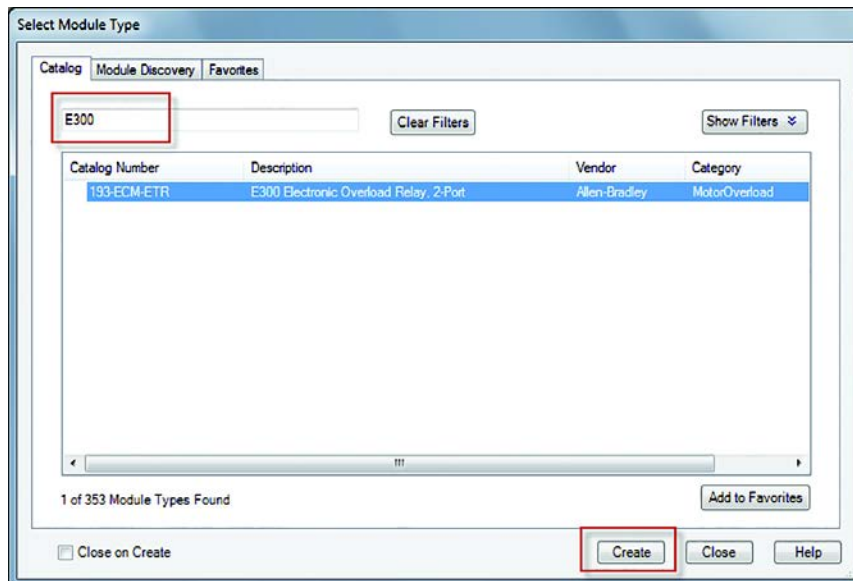

4. Type a Name for the E300 relay, and select OK.

The E300 device profile appears in your projects Organizer Menu under Ethernet. The next step in properly configuring your E300 Relay to your project is to upload the E300 module properties to the project.

Upload Parameters

The process of updating your new or existing project with the correct parameter settings and firmware to communicate between your E300 relay and programmable logic controller (PLC) has become significantly easier. By using the “Upload” button on the E300 Module Definition, you can upload the firmware revision, module types, and existing configuration parameters into your project. The following steps show the step-by-step process to perform this action.

1. Double click on the appropriate E300 device profile. In the general display, select Change.
2. Once the Module Definition tab appears, click Upload. Select the appropriate E300 relay that is on the EtherNet/IP network, and click OK.

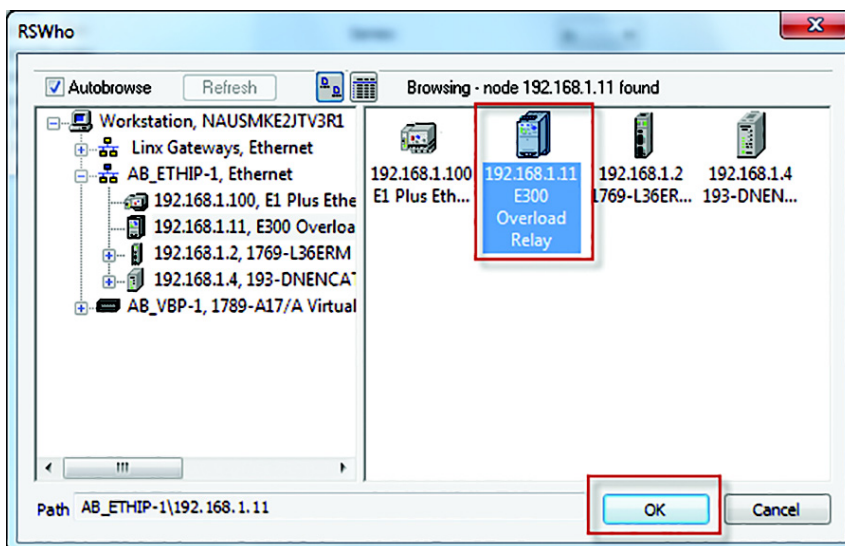
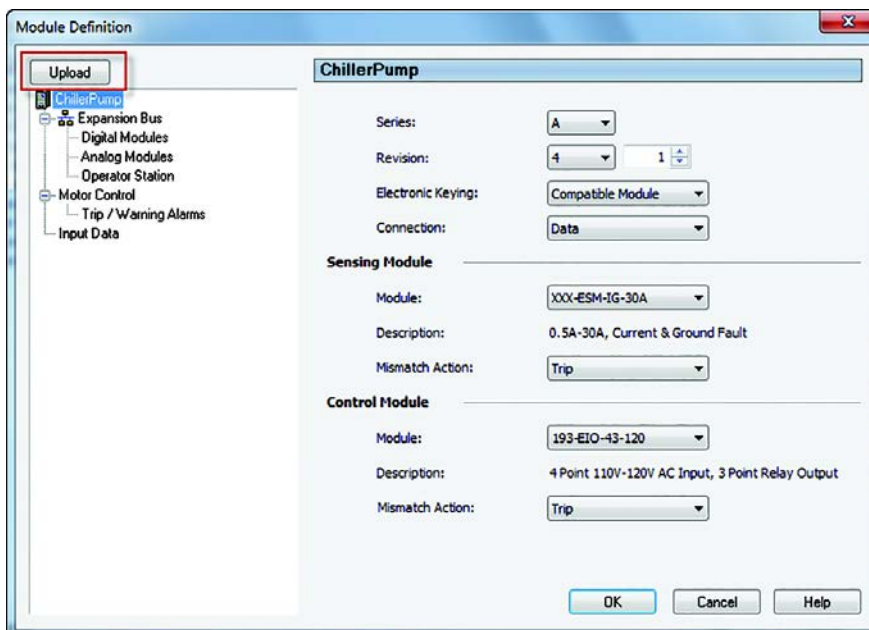

3. If the upload is successful, a display appears indicating the success of this command. Click OK to continue.

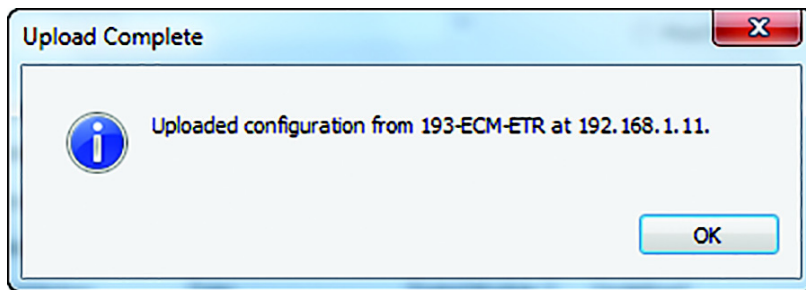

The firmware revision, module types, and existing configuration parameters of the E300 relay are now uploaded into your project.

Set the Operating Mode

The Operating Mode is an embedded motor control program that is used to reduce motor starter control wiring and simplify PLC programs. You can choose from 47 different Operating Modes to accommodate the most common motor control strategies. For more information, see [Appendix A](#). Follow the steps below to choose the correct Operating Mode for your motor starter.

1. Double click on the E300 device profile. In the general display, select Change to open the Module Definition Window.
2. Click on the Motor Control Operating Mode window.
3. Using the dropdown fields, select the appropriate Control Strategy and relay settings that correspond to your motor starter. When you are finished, click OK to close the Module Definition display.

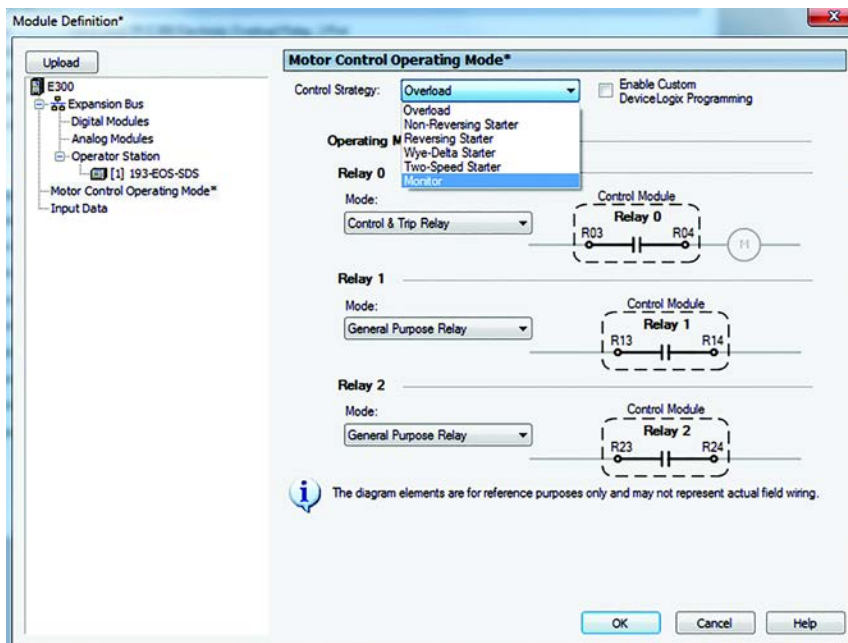

- Click Apply to add the changes to the project.

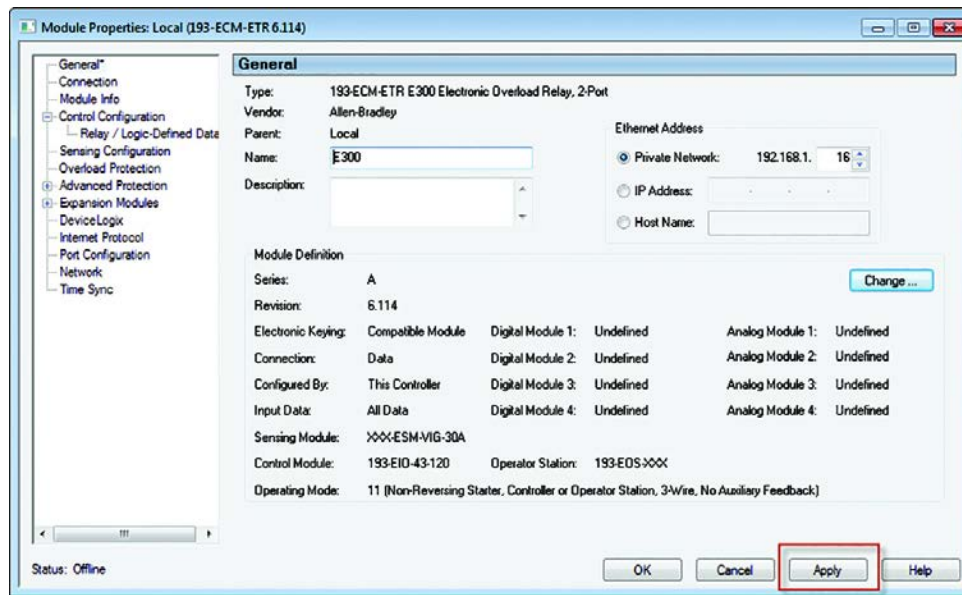

IMPORTANT If you plan to use a custom DeviceLogix program in your project, be sure to check the 'Enable Custom DeviceLogix Programming' box located next to the Control Strategy dropdown field.

Set the FLA

The FLA1 and FLA2 parameters are the motor's current ratings found on the motor's nameplate. These values are used in the E300 relay thermal overload algorithm. You can adjust this parameter in the Overload Protection display and press Apply. See [Figure 8](#).

Figure 8 - Overload Protection Tab

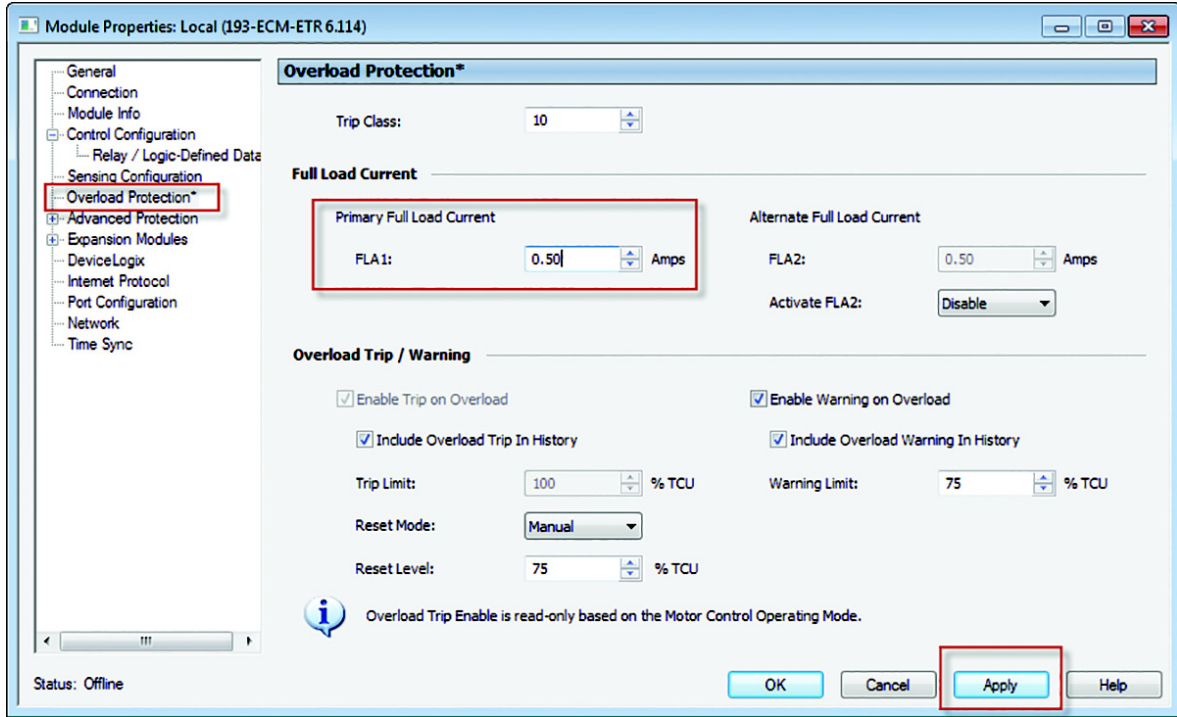

While the FLA setting is the minimal adjustment to be made on this display, you can also configure the trip class and the reset mode (manual or automatic) here.

Download the Project to the Logix Controller

The final procedure to applying these project and E300 relay changes is to download the updated project to the Logix controller.

1. To download, click on the Controller Icon in the upper left of your Studio 5000/Logix Designer home screen and select Download from the dropdown menu.

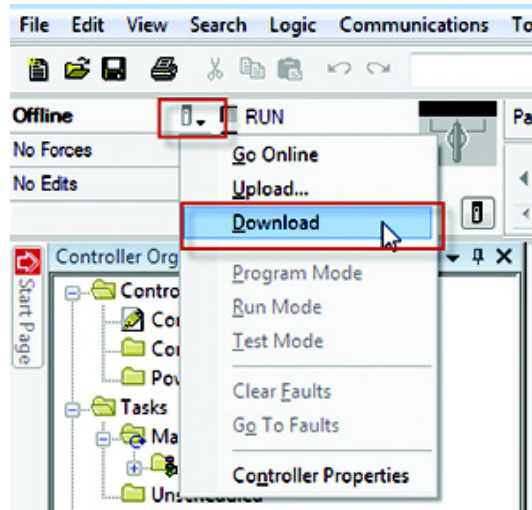

2. When prompted with a warning to download the offline project to the controller, select Download

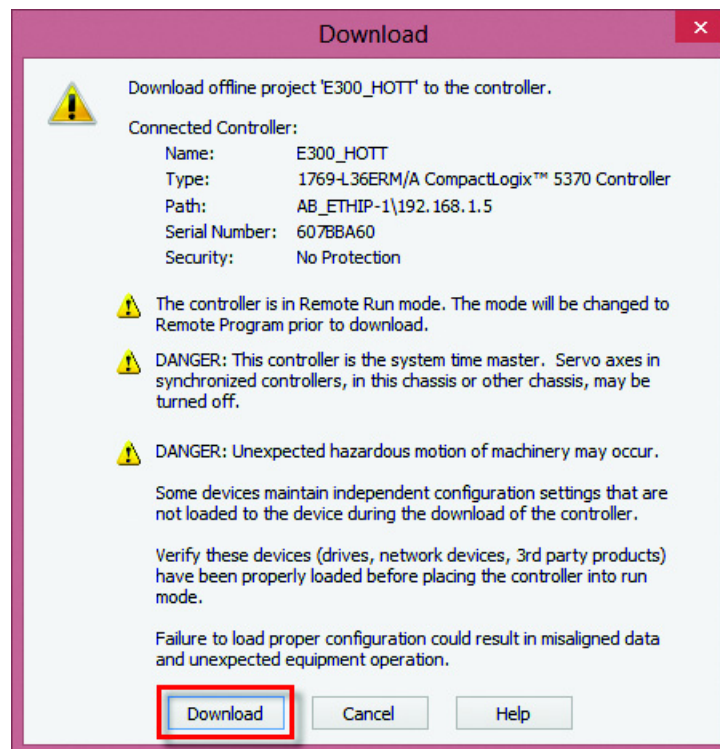

3. A pop-up appears, stating that the download is complete. Select Yes to complete the download and put the controller back in Remote Run Mode.

Use Output Tags to Control the Motor

To have the Logix controller operate the motor, you need to enable a specific output tag for the appropriate Operating Mode and start type.

Non-Reversing Start Command

Wye (Star) / Delta Start Command

Forward Start Command (Reversing Starter)

Speed 1 Start Command (2-Speed Starter)

A non-reversing starter, a wye (Star) / delta starter, the forward start command for a reversing starter, and the speed 1 start command for a two-speed starter use output tag :O.LogicDefinedPt00Data to start the motor.

Name	Value	Force Mask	Style	Data Type
E300:O	{...}	{...}		AB:E300:O:1
- E300:O.Pt00Data	0		Decimal	BOOL
- E300:O.Pt01Data	0		Decimal	BOOL
- E300:O.Pt02Data	0		Decimal	BOOL
- E300:O.Digital1Pt00Data	0		Decimal	BOOL
- E300:O.Digital1Pt01Data	0		Decimal	BOOL
- E300:O.Digital2Pt00Data	0		Decimal	BOOL
- E300:O.Digital2Pt01Data	0		Decimal	BOOL
- E300:O.Digital3Pt00Data	0		Decimal	BOOL
- E300:O.Digital3Pt01Data	0		Decimal	BOOL
- E300:O.Digital4Pt00Data	0		Decimal	BOOL
- E300:O.Digital4Pt01Data	0		Decimal	BOOL
- E300:O.LogicDefinedPt00Data	1		Decimal	BOOL
- E300:O.LogicDefinedPt01Data	0		Decimal	BOOL
- E300:O.TripReset	0		Decimal	BOOL
- E300:O.EmergencyStartEn	0		Decimal	BOOL
- E300:O.RemoteTrip	0		Decimal	BOOL
- E300:O.OperatorStationILED	0		Decimal	BOOL
- E300:O.OperatorStationIILED	0		Decimal	BOOL
- E300:O.OperatorStationLocalLED	0		Decimal	BOOL
- E300:O.OperatorStationRemoteLED	0		Decimal	BOOL
- E300:O.OperatorStationOLEd	0		Decimal	BOOL

Reverse Start Command (Reversing Starter)

Speed 2 Start Command (2-Speed Starter)

The reverse start command for a reversing starter and the speed 2 start command for a two-speed starter will use output tag :O.LogicDefinedPt01Data to start the motor.

Name	Value	Force Mask	Style	Data Type
E300:O	{...}	{...}		AB:E300:O:1
E300:O.Pt00Data	0		Decimal	BOOL
E300:O.Pt01Data	0		Decimal	BOOL
E300:O.Pt02Data	0		Decimal	BOOL
E300:O.Digital1Pt00Data	0		Decimal	BOOL
E300:O.Digital1Pt01Data	0		Decimal	BOOL
E300:O.Digital2Pt00Data	0		Decimal	BOOL
E300:O.Digital2Pt01Data	0		Decimal	BOOL
E300:O.Digital3Pt00Data	0		Decimal	BOOL
E300:O.Digital3Pt01Data	0		Decimal	BOOL
E300:O.Digital4Pt00Data	0		Decimal	BOOL
E300:O.Digital4Pt01Data	0		Decimal	BOOL
E300:O.LogicDefinedPt00Data	0		Decimal	BOOL
E300:O.LogicDefinedPt01Data	1		Decimal	BOOL
E300:O.TripReset	0		Decimal	BOOL
E300:O.EmergencyStartEn	0		Decimal	BOOL
E300:O.RemoteTrip	0		Decimal	BOOL
E300:O.OperatorStationI1LED	0		Decimal	BOOL
E300:O.OperatorStationI1LED	0		Decimal	BOOL
E300:O.OperatorStationLocalLED	0		Decimal	BOOL
E300:O.OperatorStationRemoteLED	0		Decimal	BOOL
E300:O.OperatorStationOLEDD	0		Decimal	BOOL

- Overload Start Command

The start command for an E300 overload relay that is in an Overload based Operating Mode use output tag :O.Pt00Data, :O.Pt01Data, or :O.Pt02Data to start the motor. This depends on which output relay was wired to contactor coil.

E300:O	{...}	{...}		AB:E300:O:1
E300:O.Pt00Data	0		Decimal	BOOL
E300:O.Pt01Data	0		Decimal	BOOL
E300:O.Pt02Data	0		Decimal	BOOL
E300:O.Digital1Pt00Data	0		Decimal	BOOL
E300:O.Digital1Pt01Data	0		Decimal	BOOL
E300:O.Digital2Pt00Data	0		Decimal	BOOL
E300:O.Digital2Pt01Data	0		Decimal	BOOL
E300:O.Digital3Pt00Data	0		Decimal	BOOL
E300:O.Digital3Pt01Data	0		Decimal	BOOL
E300:O.Digital4Pt00Data	0		Decimal	BOOL
E300:O.Digital4Pt01Data	0		Decimal	BOOL
E300:O.LogicDefinedPt00Data	0		Decimal	BOOL
E300:O.LogicDefinedPt01Data	0		Decimal	BOOL
E300:O.TripReset	0		Decimal	BOOL
E300:O.EmergencyStartEn	0		Decimal	BOOL
E300:O.RemoteTrip	0		Decimal	BOOL
E300:O.OperatorStationI1LED	0		Decimal	BOOL
E300:O.OperatorStationI1LED	0		Decimal	BOOL
E300:O.OperatorStationLocalLED	0		Decimal	BOOL
E300:O.OperatorStationRemoteLED	0		Decimal	BOOL
E300:O.OperatorStationOLEDD	0		Decimal	BOOL

Notes:

Device Configuration Using the Diagnostic Station

The E300 Electronic Overload Relay supports a Diagnostic Station on the E300 Expansion Bus (requires Control Module firmware v3.000 and higher). The Diagnostic Station allows you to view any E300 relay parameter and edit any configuration parameter. This chapter explains how to use the navigation keys on the Diagnostic Station to view a parameter and edit the minimum required configuration parameters.

Before You Begin

Before you use the diagnostic station, you must first have completed the installation explained in [Chapter 1](#).

What You Need

- E300 relay with diagnostic station that is connected to an E300 expansion bus

Follow These Steps

The E300 Diagnostic Station allows you to edit configuration parameters by using a group menu system or by a linear list. At a minimum you must configure ConfigPreset (Parameter 164) and FLASetting (Parameter 171) to make the E300 function properly. To start the navigation menu, press the  key. You are prompted to view parameters by groups or parameters in a linear list.

Edit Configuration Preset (Parameter 164)

1. Choose a navigation method and display ConfigPreset (Parameter 164)

Param #0164
ConfigPreset
Ready

2. Press the  key to modify the value.

3. Use the ▲ or ▼ keys to select the appropriate Operating Mode. See [Appendix A](#) for a description of the available Operating Modes.
4. Press ← to save the chosen preset configuration values for the chosen Operating Mode or press ESC to cancel the modification and restore the previous value.
5. Press ESC to return to the navigation menu.

Edit Full Load Amps (Parameter 171)

1. Choose a navigation method and display FLASetting (Parameter 171).

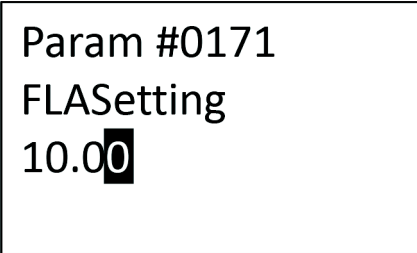

Param #0171
FLASetting
10.00

2. Press the ← key to modify the value.
3. Use the ▲ or ▼ keys to select the new value for the digit on the left side of the of the value. Press the SEL button to advance the cursor one position to the right. Use the up UP or DOWN keys to select the appropriate digit. Continue this process until the final value has be configured.
4. Press ← to save the new value or press ESC to cancel the modification and restore the previous value.
5. Press ESC to return to the navigation menu.

Device Configuration Using the Web Server

In order to make changes to your E300 relay via the Web Server, it needs to be enabled. In Administrative Mode, you can change any configuration parameter of the E300 relay including permanently enabling the embedded web server. This chapter explains how to put the E300 relay into Administrative Mode to edit the minimum required parameters ConfigPreset (Parameter 164) and FLASetting (Parameter 171) using the E300 Web Server.

Before You Begin

Before you can configure the E300 relay via the web server, you must first have completed the configuration explained in [Chapter 1](#).

What You Need

- E300 relay that has been configured with an IP address and is connected to a network

Follow These Steps

Complete the following steps to configure the E300 relay via the web server. When you have finished, you will have configured the minimum required parameters for the E300 relay.

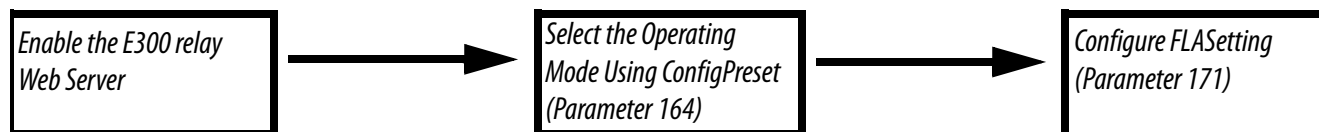

Enabling the E300 Relay Web Server

1. Enter Administrative Mode by turning the rotary dials on the E300 relay communication module to 000 and cycle power on the E300 relay.
2. Using a personal computer, open a web browser and type the IP address of the E300 relay.
3. To permanently enable the E300 Web Server, navigate to Administrative Settings->Network Configuration.
4. When you are prompted for a user name and password, enter "Administrator" for the user name, and enter the appropriate password.

The default password is <blank> for an E300 EtherNet/IP Communication Module with v1.003 firmware. For all other firmware revisions, the default password is the serial number of the E300 EtherNet/IP Communication Module. You can find the serial number under the front sliding panel of the communication module



- 5. If your E300 relay has an EtherNet/IP Module with firmware revision v1.001 - v1.007, proceed to [step 6](#).

If your E300 relay has an EtherNet/IP Module with firmware revision v1.008 and higher you will be required to immediately change the password to any value except the serial number.

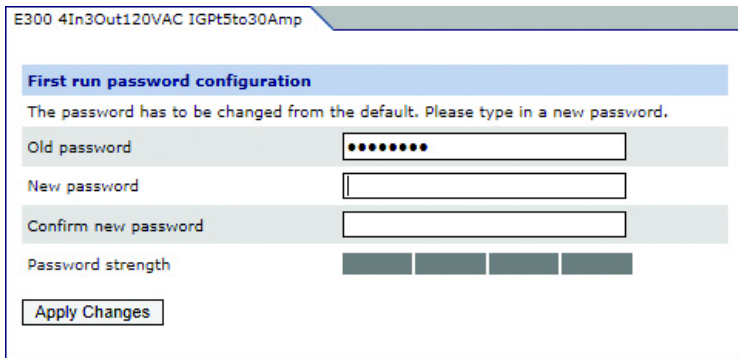

- 6. Enable the Web Server Control (under the Network Configuration tab) and press Apply Changes.

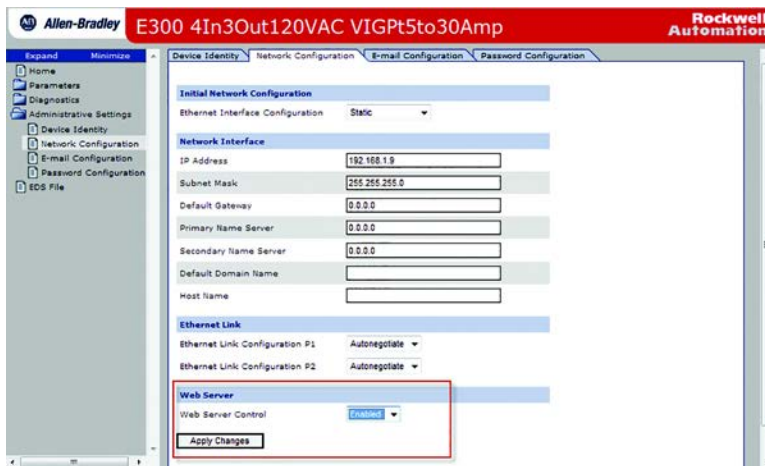

Select the Operating Mode with ConfigPreset (Parameter 164)

Follow the steps below to select the Operating Mode for the E300 relay.

1. Navigate to Parameters->Command and press the Edit button.

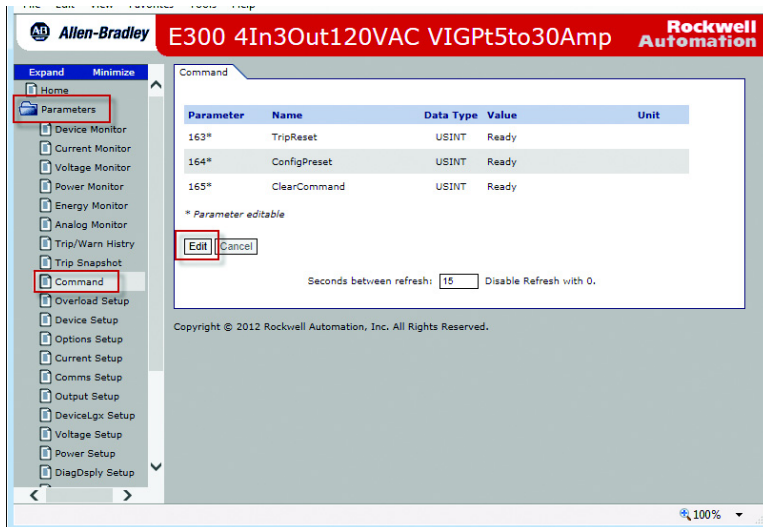

2. Click the down arrow on the pull-down box for ConfigPreset (Parameter 164) to select the appropriate Operating Mode for the motor starter.

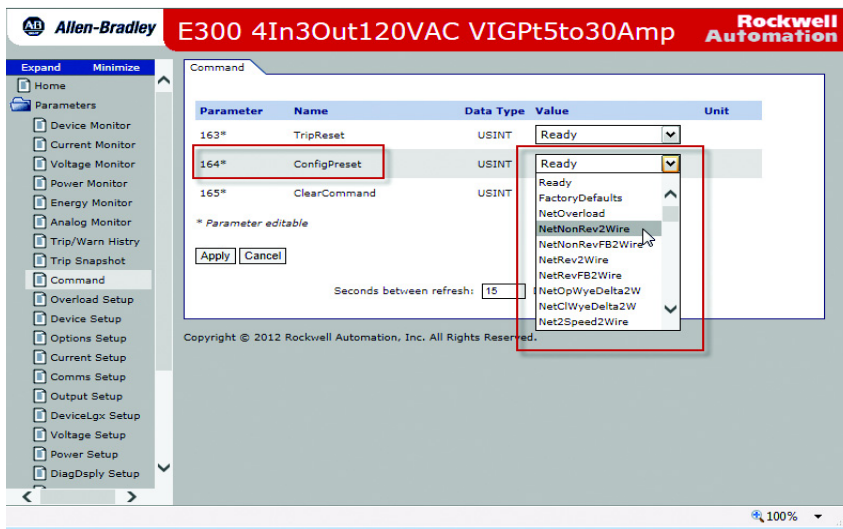

- Click Apply to download the new parameter value to the device.

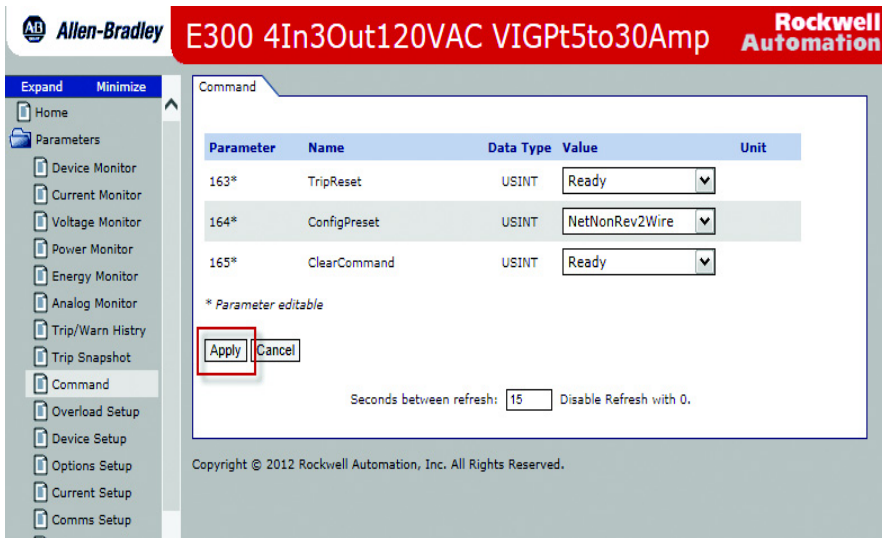

- A confirmation window appears. Press OK.

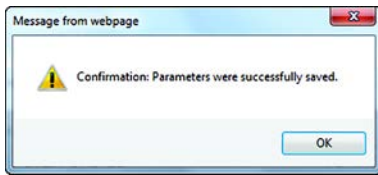

Set Motor FLA Using FLASetting (Parameter 171)

Use the following steps to edit the motor FLA setting using the web interface of the E300 relay EtherNet/IP Communication Module.

- Select the Overload Setup parameter group that contains the parameter FLASetting (Parameter 171), then click the Edit button.

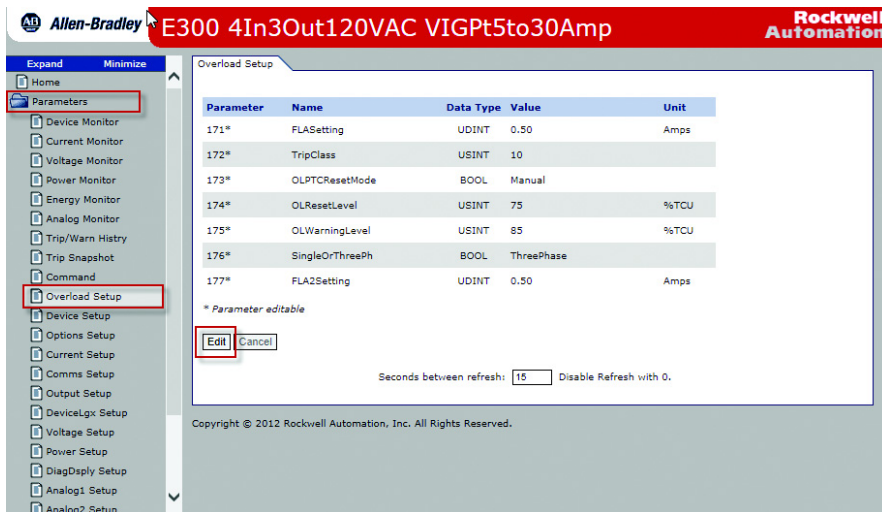

2. Enter the motor FLA in FLASetting (Parameter 171). Click on Apply to apply this change to the E300 relay.

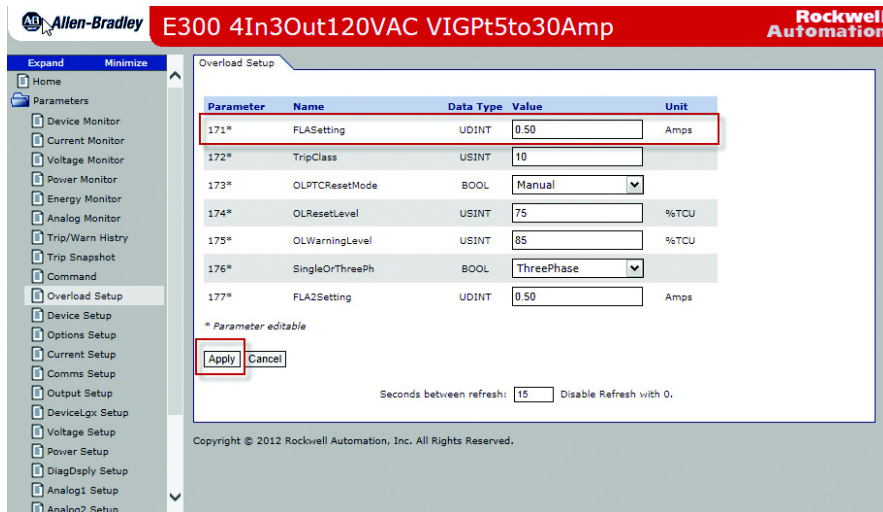

3. A confirmation window appears. Press OK.

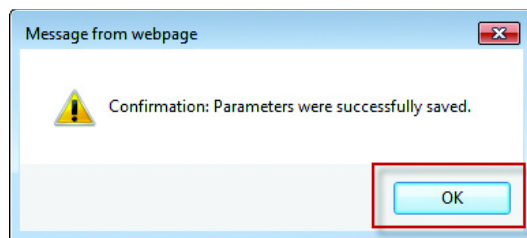

Notes:

E300 Relay Operating Mode Summary

This section summarizes the preset configurations for the various E300 relay Operating Modes that can be selected using the ConfigPreset (Parameter 164) command.

Detailed information about the E300 relay Operating Modes is found in Chapter 5 of the E300 Electronic Overload Relay User Manual, publication [193-UM015](#).

The default Operating Mode is (2) - Network Overload. The four most common Operating Modes are:

- (2) - Network Overload
- (4) - Network Non-Reversing Starter
- (11) - Network & Operator Station Non-Reversing Starter
- (16) - Network & Local I/O 2-Wire Control Non-Reversing Starter

Table 1 - E300 Relay Preset Configurations (Parameter 164)

Value	Enumeration	Operating Mode			Description
		Control Source	Starter Type	Control Option	
0	Ready				No operation
1	FactoryDefaults				Set all parameters to their default setting
2	NetOverload	Network	Overload		A controller is the control source for a traditional overload relay with a trip contact
3	NetNonRev2Wire	Network	Non-reversing		A controller is the control source for a non-reversing starter that has a maintained signal
4	NetNonRevFB2Wire	Network	Non-reversing	With Feedback Protection	A controller is the control source for a non-reversing starter that has a maintained signal, and the E300 relay will trip if the contactor auxiliary is not closed
5	NetRev2Wire	Network	Reversing		A controller is the control source for a reversing starter that has a maintained signal
6	NetRevFB2Wire	Network	Reversing	With Feedback Protection	A controller is the control source for a reversing starter that has a maintained signal, and the E300 relay will trip if the contactor auxiliary is not closed
7	NetOpWyeDelta2W	Network	Wye/Delta	Open Transition	A controller is the control source for a Wye/Delta starter that has a maintained signal and has an open transition
8	NetClWyeDelta2W	Network	Wye/Delta	Closed Transition	A controller is the control source for a Wye/Delta starter that has a maintained signal and has a closed transition
9	Net2Speed2Wire	Network	2-Speed		A controller is the control source for a 2-Speed starter that has a maintained signal
10	Net2SpeedFB2Wire	Network	2-Speed	With Feedback Protection	A controller is the control source for a 2-Speed starter that has a maintained signal, and the E300 relay will trip if the contactor auxiliary is not closed
11	NetOSNonRev3Wir	Network & Operator Station	Non-reversing		A controller that has a maintained signal and an Operator Station with momentary control buttons are the control sources for a non-reversing starter
12	NetOSNonRevFB3W	Network & Operator Station	Non-reversing	With Feedback Protection	A controller that has a maintained signal and an Operator Station with momentary control buttons are the control sources for a non-reversing starter, and the E300 relay will trip if the contactor auxiliary is not closed
13	NetOSRev3Wire	Network & Operator Station	Reversing		A controller that has a maintained signal and an Operator Station with momentary control buttons are the control sources for a reversing starter
14	NetOSOpWyeDel3W	Network & Operator Station	Wye/Delta	Open Transition	A controller that has a maintained signal and an Operator Station with momentary control buttons are the control sources for a Wye/Delta starter that has an open transition
15	NetOS2Speed3Wir	Network & Operator Station	2-Speed		A controller that has a maintained signal and an Operator Station with momentary control buttons are the control sources for a 2-speed starter

Table 1 - E300 Relay Preset Configurations (Parameter 164)

Value	Enumeration	Operating Mode			Description
		Control Source	Starter Type	Control Option	
16	NetLIONonRev2Wir	Network & Local I/O	Non-reversing	2 Wire Control	A controller that has a maintained signal and a maintained selector switch are the control sources for a non-reversing starter
17	NetLIONonRevFB2W	Network & Local I/O	Non-reversing	2 Wire Control with Feedback Protection	A controller that has a maintained signal and a maintained selector switch are the control sources for a non-reversing starter, and the E300 relay will trip if the contactor auxiliary is not closed of the contactor
18	NetLIONonRev3Wir	Network & Local I/O	Non-reversing	3 Wire Control	A controller that has a maintained signal and two momentary push buttons are the control sources for a non-reversing starter
19	NetLIONonRevFB3W	Network & Local I/O	Non-reversing	3 Wire Control with Feedback Protection	A controller that has a maintained signal and two momentary push buttons are the control sources for a non-reversing starter, and the E300 relay will trip if the contactor auxiliary is not closed of the contactor
20	NetLIORev2Wire	Network & Local I/O	Reversing	2 Wire Control	A controller that has a maintained signal and a maintained selector switch are the control sources for a reversing starter
21	NetLIORev3Wire	Network & Local I/O	Reversing	3 Wire Control	A controller that has a maintained signal and three momentary push buttons are the control sources for a reversing starter
22	NetLIOpWyeDel2W	Network & Local I/O	Wye/Delta	2 Wire Control with Open Transition	A controller that has a maintained signal and a maintained selector switch are the control sources for a wye/delta starter with an open transition
23	NetLIOCIWyeDel2W	Network & Local I/O	Wye/Delta	2 Wire Control with Closed Transition	A controller that has a maintained signal and a maintained selector switch are the control sources for a wye/delta starter with a closed transition
24	NetLIO2Speed2Wir	Network & Local I/O	2-Speed	2 Wire Control	A controller that has a maintained signal and a maintained selector switch are the control sources for a 2-speed starter
25	NetLIO2Speed3Wir	Network & Local I/O	2-Speed	3 Wire Control	A controller that has a maintained signal and three momentary push buttons are the control sources for a 2-speed starter
26	OSOverload	Operator Station	Overload		An Operator Station with a momentary trip reset button is the control source for a traditional overload relay with a trip contact
27	OSNonRev3Wire	Operator Station	Non-reversing		An Operator Station with momentary control buttons is the control source for a non-reversing starter
28	OSNonRevFB3Wire	Operator Station	Non-reversing	With Feedback Protection	An Operator Station with momentary control buttons is the control source for a non-reversing starter, and the E300 relay will trip if the contactor auxiliary is not closed of the contactor
29	OSRev3Wire	Operator Station	Reversing		An Operator Station with momentary control buttons is the control source for a reversing starter
30	OSRevFB3Wire	Operator Station	Reversing	With Feedback Protection	An Operator Station with momentary control buttons is the control source for a reversing starter, and the E300 relay will trip if the contactor auxiliary is not closed
31	OSOpWyeDel3W	Operator Station	Wye/Delta	Open Transition	An Operator Station with momentary control buttons is the control source for a wye/delta starter with an open transition
32	OSCIWyeDelta3W	Operator Station	Wye/Delta	Closed Transition	An Operator Station with momentary control buttons is the control source for a wye/delta starter with a closed transition
33	OS2Speed3Wire	Operator Station	2-Speed		An Operator Station with momentary control buttons is the control source for a 2-speed starter
34	OS2SpeedFB3Wire	Operator Station	2-Speed	With Feedback Protection	An Operator Station with momentary control buttons is the control source for a 2-speed starter, and the E300 relay will trip if the contactor auxiliary is not closed
35	LIOOverload	Local I/O	Overload		A momentary push button for a trip reset is the control source for a traditional overload relay with a trip contact
36	LIONonRev2Wire	Local I/O	Non-reversing	2 Wire Control	A maintained selector switch is the control source for a non-reversing starter
37	LIONonRevFB2Wire	Local I/O	Non-reversing	2 Wire Control with Feedback Protection	A maintained selector switch is the control sources for a non-reversing starter, and the E300 relay will trip if the contactor auxiliary is not closed of the contactor
38	LIONonRev3Wire	Local I/O	Non-reversing	3 Wire Control	Two momentary push buttons are the control sources for a non-reversing starter
39	LIONonRevFB3Wire	Local I/O	Non-reversing	3 Wire Control with Feedback Protection	Three momentary push buttons are the control sources for a non-reversing starter, and the E300 relay will trip if the contactor auxiliary is not closed of the contactor
40	LIORev2Wire	Local I/O	Reversing	2 Wire Control	A maintained selector switch is the control source for a reversing starter
41	LIORevFB2Wire	Local I/O	Reversing	2 Wire Control with Feedback Protection	A maintained selector switch is the control source for a reversing starter, and the E300 relay will trip if the contactor auxiliary is not closed of the contactor
42	LIORev3Wire	Local I/O	Reversing	3 Wire Control	Three momentary push buttons are the control sources for a reversing starter
43	LIOOpWyeDelta2W	Local I/O	Wye/Delta	2 Wire Control with Open Transition	A selector switch is the control source for a wye/delta starter with an open transition

Table 1 - E300 Relay Preset Configurations (Parameter 164)

Value	Enumeration	Operating Mode			Description
		Control Source	Starter Type	Control Option	
44	LI0CIWyeDelta2W	Local I/O	Wye/Delta	2 Wire Control with Closed Transition	A selector switch is the control source for a wye/delta starter with a closed transitions
45	LI0OpWyeDelta3W	Local I/O	Wye/Delta	3 Wire Control with Open Transition	Two momentary push buttons are the control sources for a wye/delta starter with an open transitions
46	LI02Speed2Wire	Local I/O	2-Speed	2 Wire Control	A maintained selector switch is the control source for a 2-speed starter
47	LI02SpeedFB2Wire	Local I/O	2-Speed	2 Wire Control with Feedback Protection	A maintained selector switch is the control source for a 2-speed starter, and the E300 relay will trip if the contactor auxiliary is not closed of the contactor
48	LI02Speed3Wire	Local I/O	2-Speed	3 Wire Control	Three momentary push buttons are the control sources for a 2-speed starter
49	CustomOverload	Custom	Overload		A custom DeviceLogix program can be used to control the E300 relay with an Overload operating mode
50	CustomNonRev	Custom	Non-reversing		A custom DeviceLogix program can be used to control the E300 relay for a non-reversing starter
51	CustomReverser	Custom	Reversing		A custom DeviceLogix program can be used to control the E300 relay for a reversing starter
52	CustomWyeDelta	Custom	Wye/Delta		A custom DeviceLogix program can be used to control the E300 relay for a wye/delta starter
53	Custom2Speed	Custom	2-Speed Starter		A custom DeviceLogix program can be used to control the E300 relay for a 2-speed starter
54	CustomMonitor	Custom	Monitor		The E300 relay can be used as a monitoring device, and all protections can be disabled

Notes:

-
- A
 - add-on profile 19
 - administrative mode 27
 - AOP 19
 - Assembly 7
 - assembly
 - communication module to control module 10
 - control module to sensing module 9
 - B
 - BOOTP/DHCP 15
 - C
 - communication
 - logix controller 19
 - communication module 8
 - communication module to control module assembly 10
 - configuration
 - BOOTP/DHCP utility 15
 - rotary dial addressing 15
 - control module 7
 - control module to sensing module assembly 9
 - D
 - diagnostic station 25
 - downloading
 - EDS file 17
 - project settings 24
 - E
 - editing parameters 28
 - EDS file 17
 - enabling the web server 27
 - F
 - fla 23
 - full-load current setting 23
 - I
 - I/O connectors 11
 - installation
 - i/o connectors 11
 - IP address 15
 - L
 - logix controller 19
 - M
 - module
 - assembling 7, 8
 - communication 8
 - control 7
 - sensing 7
 - O
 - operating mode 22, 28, 31
 - P
 - parameter 164 28
 - project settings 24
 - R
 - rotary dial addressing 15
 - RSLogix 5000 19
 - S
 - sensing module 7
 - studio 5000 19
 - T
 - terminology 5
 - U
 - user name 27
 - W
 - web server
 - editing parameters 28
 - enabling 27
 - wiring 13
 - control module 13
 - E300 DOL and single-phase connections 14

Notes:

Rockwell Automation Support

Use the following resources to access support information.

Technical Support Center	Knowledgebase Articles, How-to Videos, FAQs, Chat, User Forums, and Product Notification Updates.	https://rockwellautomation.custhelp.com/
Local Technical Support Phone Numbers	Locate the phone number for your country.	http://www.rockwellautomation.com/global/support/get-support-now.page
Direct Dial Codes	Find the Direct Dial Code for your product. Use the code to route your call directly to a technical support engineer.	http://www.rockwellautomation.com/global/support/direct-dial.page
Literature Library	Installation Instructions, Manuals, Brochures, and Technical Data.	http://www.rockwellautomation.com/global/literature-library/overview.page
Product Compatibility and Download Center (PCDC)	Get help determining how products interact, check features and capabilities, and find associated firmware.	http://www.rockwellautomation.com/global/support/pcdc.page

Documentation Feedback

Your comments will help us serve your documentation needs better. If you have any suggestions on how to improve this document, complete the How Are We Doing? form at http://literature.rockwellautomation.com/idc/groups/literature/documents/du/ra-du002_-en-e.pdf.

Rockwell Automation maintains current product environmental information on its website at <http://www.rockwellautomation.com/rockwellautomation/about-us/sustainability-ethics/product-environmental-compliance.page>.

Allen-Bradley, ControlLogix, DeviceLogix, E300, Logix, Rockwell Software, RSLinx, RSLogix, Studio 5000, and Rockwell Automation are trademarks of Rockwell Automation, Inc. Trademarks not belonging to Rockwell Automation are property of their respective companies.

Rockwell Otomasyon Ticaret A.Ş., Kar Plaza İş Merkezi E Blok Kat:6 34752 İçerenköy, İstanbul, Tel: +90 (216) 5698400

www.rockwellautomation.com

Power, Control and Information Solutions Headquarters

Americas: Rockwell Automation, 1201 South Second Street, Milwaukee, WI 53204-2496 USA, Tel: (1) 414.382.2000, Fax: (1) 414.382.4444

Europe/Middle East/Africa: Rockwell Automation NV, Pegasus Park, De Kleetlaan 12a, 1831 Diegem, Belgium, Tel: (32) 2 663 0600, Fax: (32) 2 663 0640

Asia Pacific: Rockwell Automation, Level 14, Core F, Cyberport 3, 100 Cyberport Road, Hong Kong, Tel: (852) 2887 4788, Fax: (852) 2508 1846

Publication 193-QR004B-EN-P - January 2017

Supersedes Publication 193-QR004A-EN-P October 2016

Copyright © 2017 Rockwell Automation, Inc. All rights reserved. Printed in the U.S.A.