

E4-E5(CM)

3G NETWORK

AND

SERVICES

Layered Architecture



The diagram illustrates a layered architecture with three distinct layers stacked vertically. Each layer is represented by a rounded, horizontal oval shape. The top layer is light yellow and labeled 'Application Layer'. The middle layer is light blue and labeled 'Control Layer'. The bottom layer is green and labeled 'Connectivity Layer'. The layers are separated by thin white gaps, and the entire stack is centered on the slide.

Application Layer

Control Layer

Connectivity Layer

Application Layer

The “Application Layer” is responsible for providing services to users via applications **regardless of the device and method in which the user accesses** the network. The Application Layer itself **is not a real network** as such important operator parts of the application Layer may, however, be realized in what are called Service Networks.

Control Layer

The “Control Layer” contains nodes that **control and direct traffic (both Circuit and Packet Switched)**. The Control Layer is realized in a Core Network. The WCDMA Core Network will contain, for example, MSCs, HLR/HSS, GMSC/TSC, SGW and possibly IMSI(IP Multimedia Sub system)

Connectivity Layer

The “connectivity Layer” consists of the transport nodes (M-MGW, SGSN and GGSN) and connects to the various access networks.

The Access Network consists of the base stations and controllers in the mobile networks(GSM, UMTS, CDMA) or fixed access, transport and connectivity network that are able to handle different types of traffic (e.g. Circuit Switched and Packet Switched data). For WCDMA, the Access Network is realized as the WCDMA Radio Access Network.

WCDMA NETWORK ARCHITECTURE

WCDMA is standardized by the Third Generation Partnership Project (3GPP).

Based on the 3GPP reference network model, the WCDMA network can be considered to consist of four major components:

- User Equipment (UE)
 - Access Network (AN)
 - Core Network (CN)
 - Network External to WCDMA
-

3GPP Network Reference Model

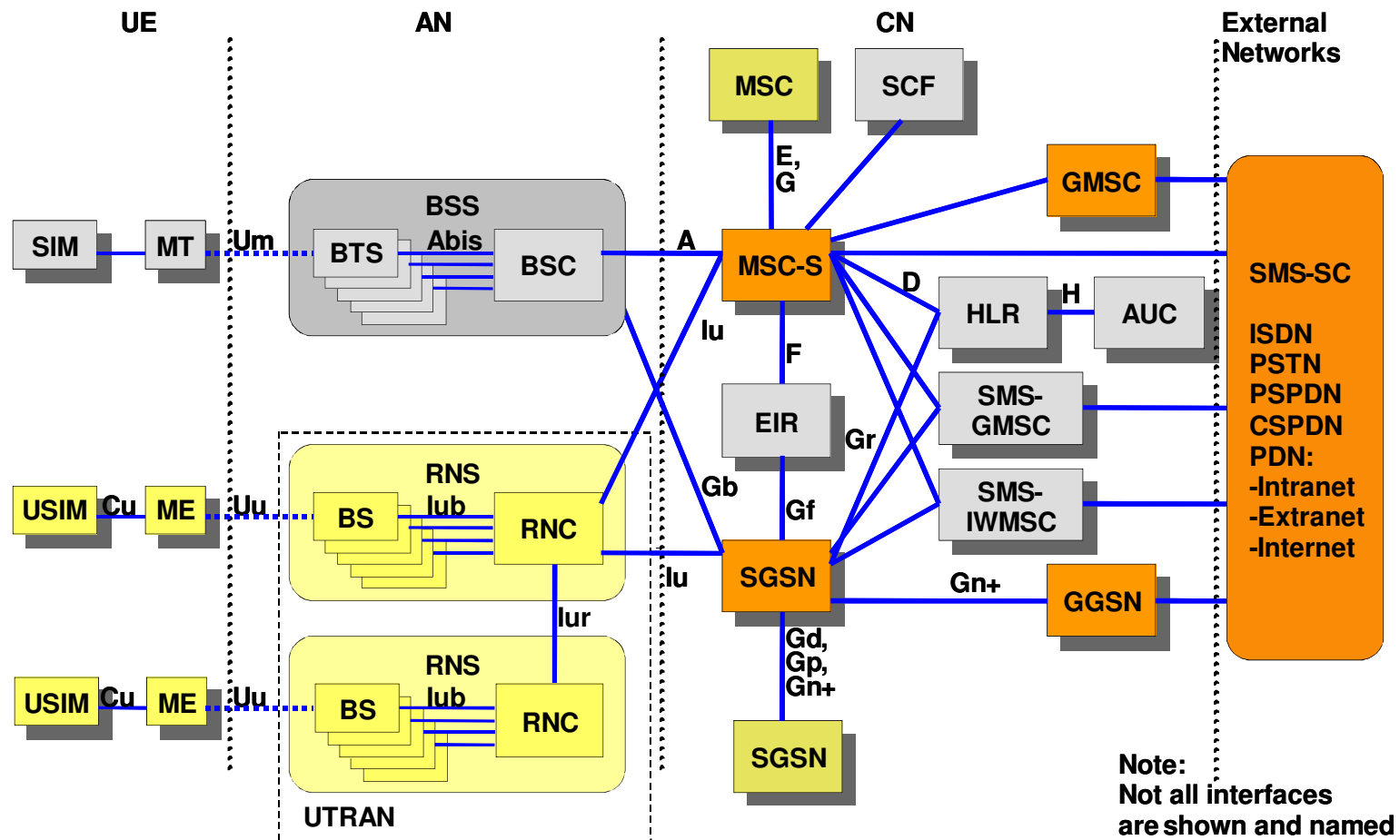

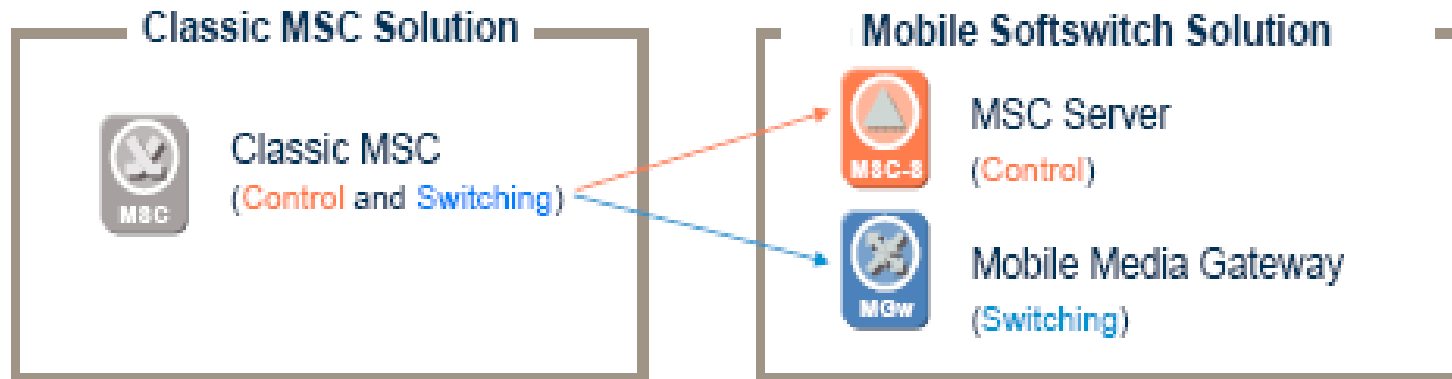

Classic circuit-switched network

Layered Architecture network

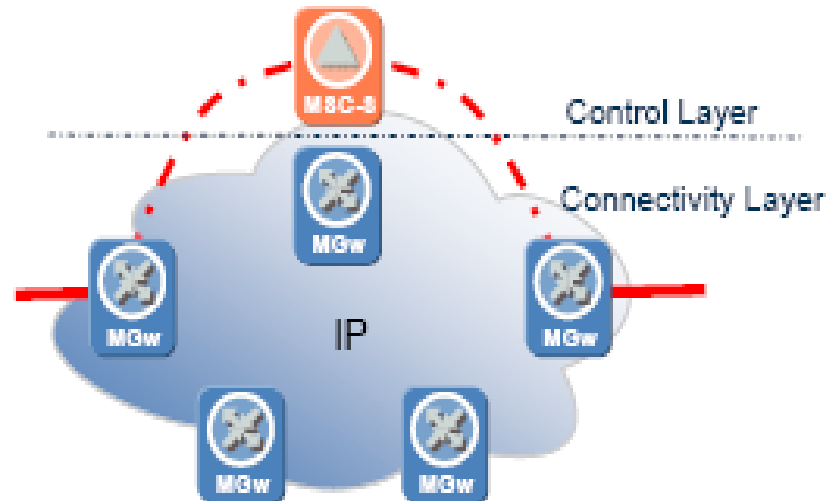
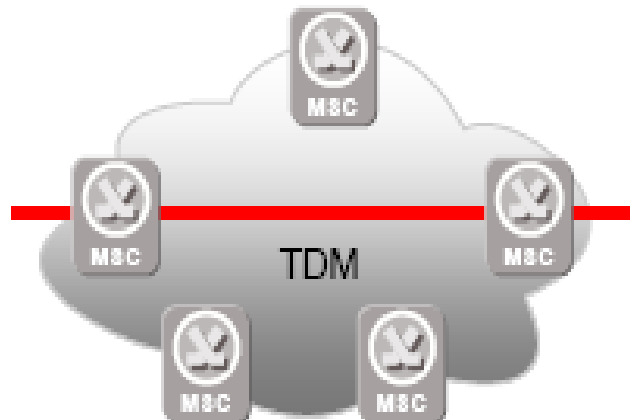

Monolithic vs Layered Architecture

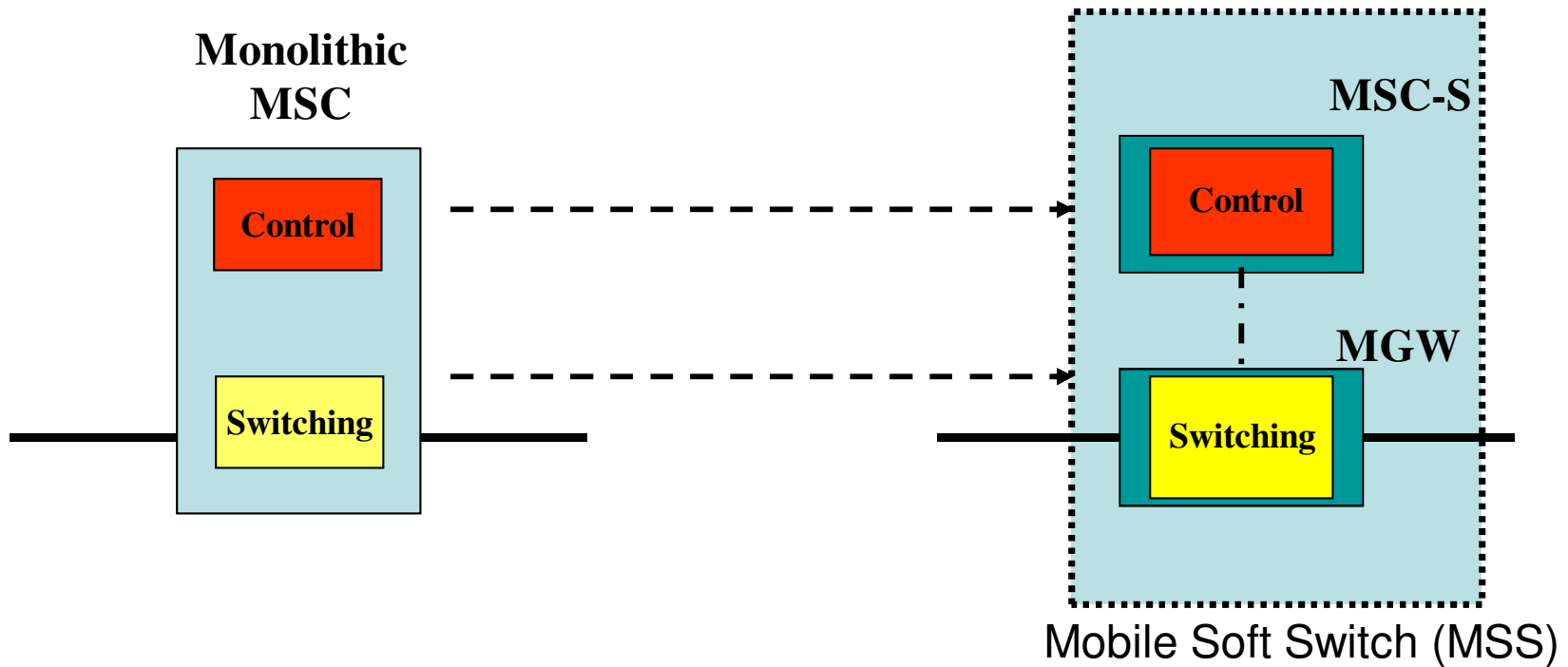

Mobile Soft switch Solution

Mobile soft switch enable a layered architecture design for the mobile circuit core , where the network functions responsible for service management & control and for transport of service data are physically & logically separated

Advantages of Mobile Soft switch Solution

- 1. Packet backbone technology (IP or ATM) enables more efficient transmission of voice traffic over the backbone by retaining the same voice coding in the backbone as is used in the air interface**
 - 2. Access independent (GSM/WCDMA) core network**
 - 3. Reduction of backbone traffic**
 - 4. Simplification of network planning through common core for WCDMA & GSM**
-

WCDMA Core Network Overview

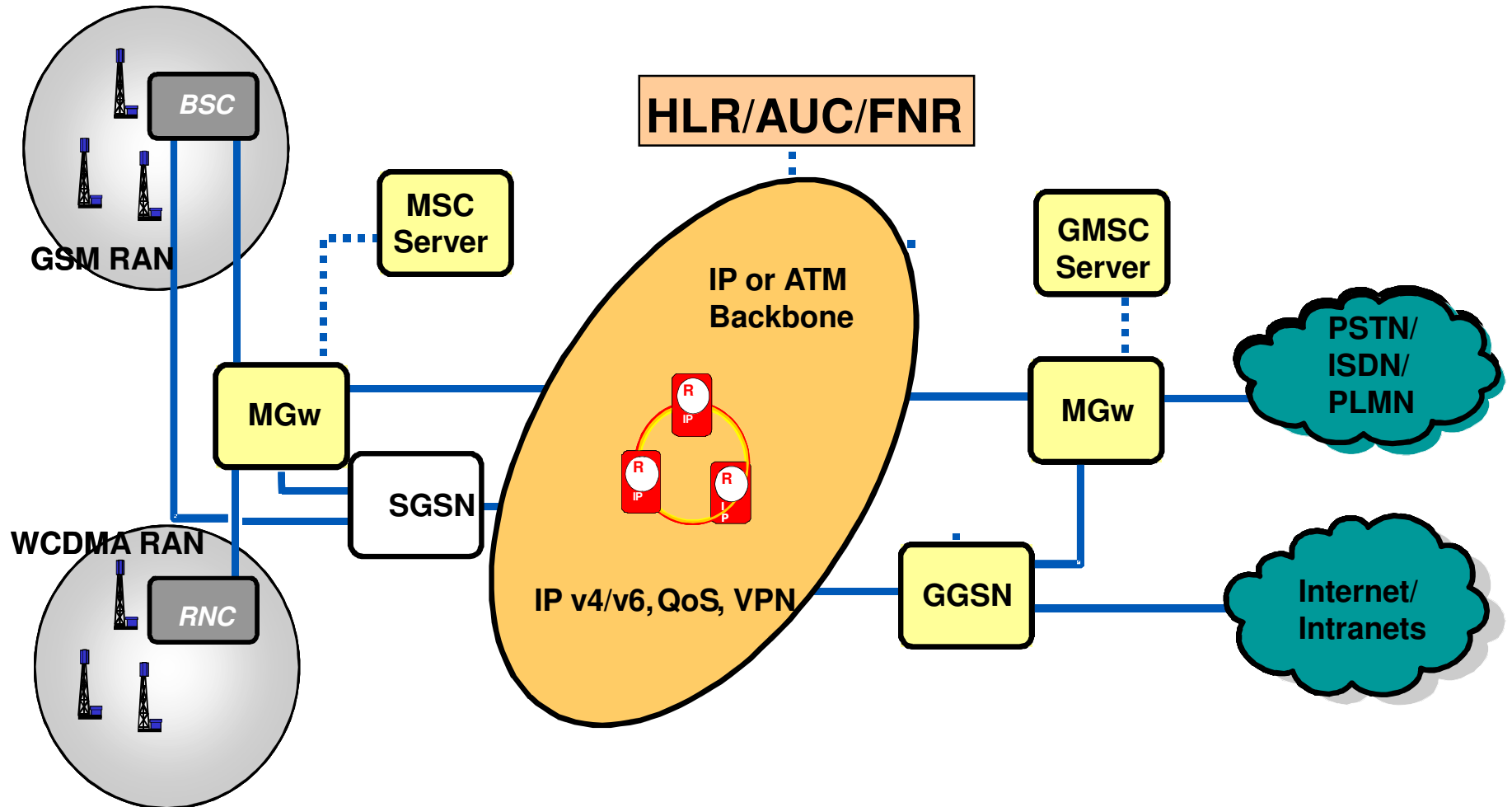

What does an MSW do ?

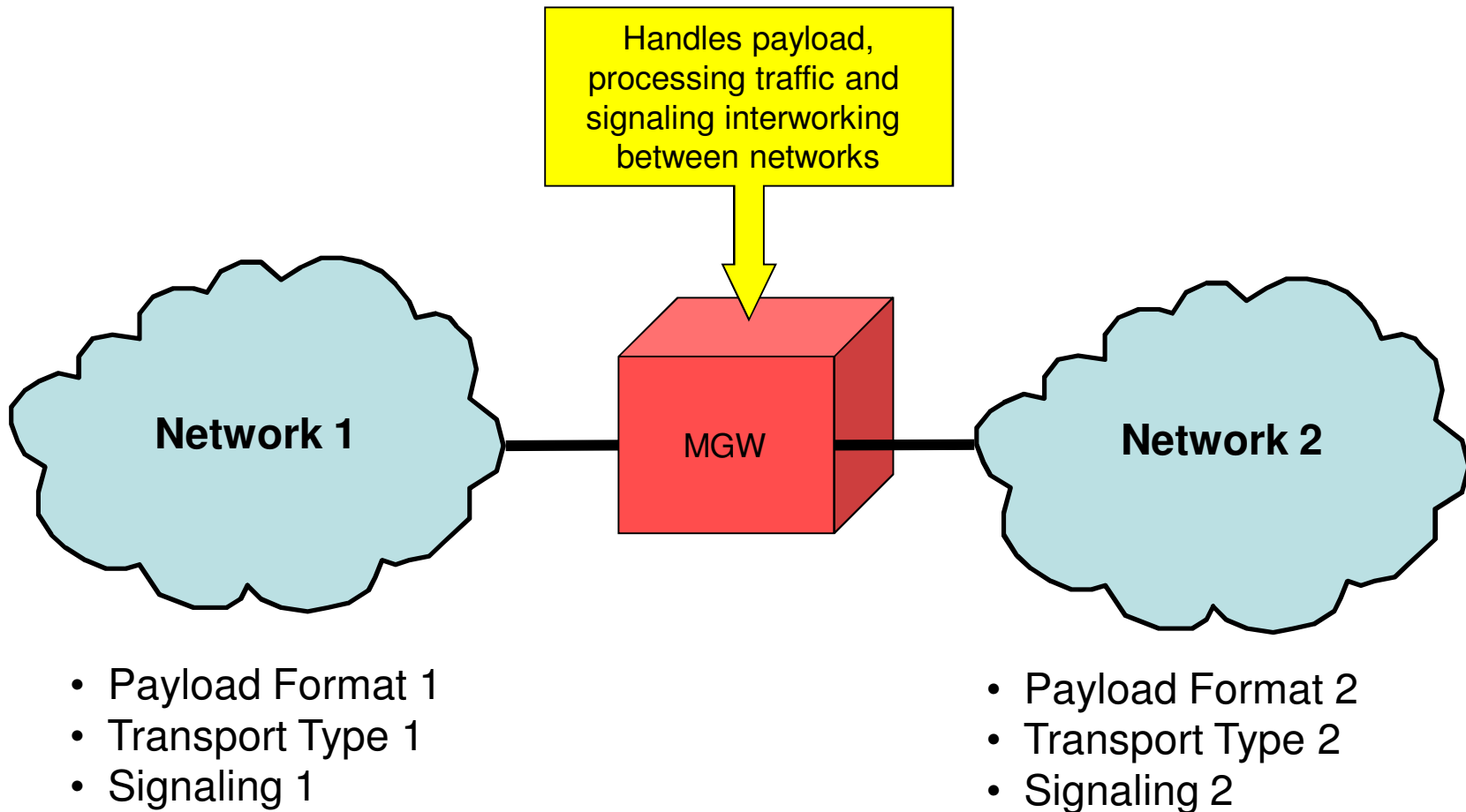

Media Gateway Controller

- Inter-working between different transport technologies (TDM, ATM and IP bearer).
- Media Stream handling (Speech Coder, Echo Canceller, Multi-Party call, Tone Sender, DTMF sender/receiver, Interactive Messaging, Code Answer and Tone Sender (CAT), Continuity Check)
- Adapting the circuit-switched data services in WCDMA and GSM.
- Signaling bearer conversion at the network edges in order to allow unified signaling bearers to be used within the core network.
- Supporting Radio Access Network interfaces.
- Routing and switching.
- Element Management.

Serving GPRS Support Node

- Session and mobility management (paging, attach, detach, Packet Data Protocol (PDP) context handling, intra- and inter-SGSN routing area update).
- Payload Handling
- Security includes features such as user and network authentication and data confidentiality through ciphering.
- CDR based charging includes functions for collecting charging information from various sources within the SGSN
- CAMEL based charging provides a real-time charging mechanism
- Configuration management functions that support definition and handling of logical relations with other network elements
- SMS over GPRS
- Support for SS7 signaling.

Gateway GPRS Support Node

- IP-address management
 - Charging data collection/output
 - Security management
 - Packet filtering
 - Packet routing / forwarding
 - QOS management
-

MSC Server

- Circuit based connection management i.e. traffic control, roaming, call routing and handover.
- Media Gateway Control
- Mobility Management
- Authentication
- Charging data collection/output
- Supporting a comprehensive set of Supplementary Services that complement and modify the Tele-services and Bearer Services.
- IN and CAMEL Services
- Security

MSC (GSM)

The MSC (GSM) handles Control Layer functions related to circuit-mode communication services within a Classical within a Classical MSC Architecture based network for example, mobility management and connection management services.

Gateway MSC Server (GMSC Server)

The main function of GMSC server is for routing calls to mobile subscribers by obtaining routing information from the subscribers HLR.

Home Location Register (HLR)

Home Location Register (HLR) serves as the primary database of subscriber information used to provide control and intelligence within the GSM/GPRS and WCDMA networks.

The HLR manages mobile subscribers profiles as well as subscriber location and activity, and also handles supplementary services.

Authentication Centre (AUC)

The Authentication Centre (AUC) contains functions for secure storage of individual subscriber identifiers and keys. AUC also includes algorithms necessary for generating authentication and ciphering data based on the subscriber keys. The authentication and ciphering data, provided by the AUC upon request, are used by different network elements to protect the network, users and operators against unauthorized use of the system.

Equipment Identity Register (EIR)

The EIR database validates mobile equipment hardware identity, The MSC can request the EIR to check if an MS has been stolen or is faulty (black listed), not type-approved (gray listed), normal registered (white listed), or unknown.

Flexible Number Register (FNR)

The FNR node offers:

- Mobile Number Portability (MNP): This feature permits an end-user to keep his MSISDN identity when changing service provider or moving subscription between two service domains within the same country.
 - Flexible Allocation of MSISDN for the GSM and WCDMA networks. This feature provides mobile operators with free allocation of subscription identity without considering the relation between MSISDN and IMSI series in the HLR.
-

3G SERVICES

Agenda

- 3G Introduction
- 3G Services
- Expected customer
3G queries
- Summary



Global 3G Story



**3G was launched in
a big way in 2002-03**

NEXT 

Global 3G Story

**But subscribers rejected
3G initially**



(There was Less than 2 % penetration in first 2 years)

3G World Wide Coverage

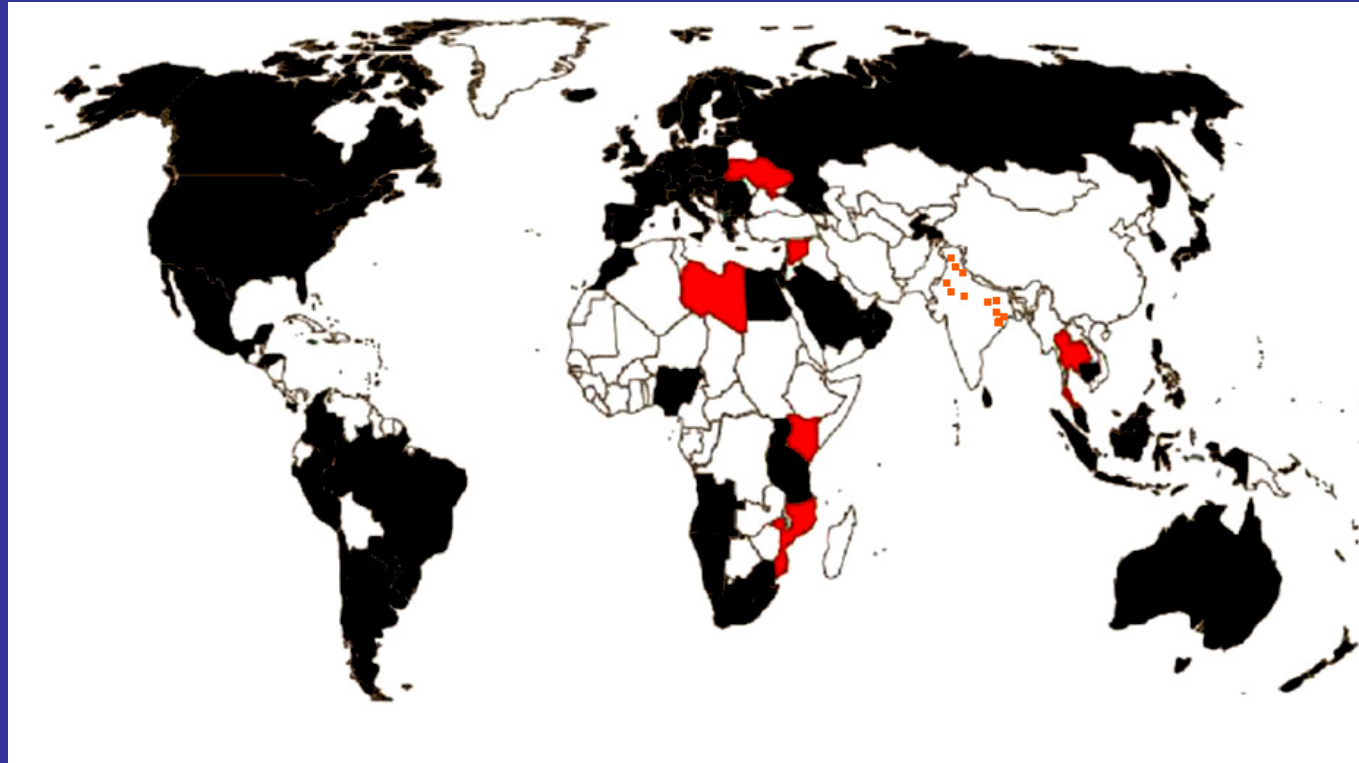

 3G Commercial Networks  3G Network Launch Commitments

**There are more than 185 commercial networks in
more than 80 countries**

India 2009-BSNL (1st movers in 3G)



- BSNL has launched 3G services in selected cities and has a clear 6 month to 1 year lead over the nearest rival.
- BSNL needs to ensure that the 3G launch is a success.

3G Overview

[What does 3G bring to the table..?]

Increased Capacity

- 📍 Increased voice capacity.
- 📍 Increased data speeds.

End user services

- 📍 Enhanced experience on existing services
- 📍 New exciting services

Revenue potential

- 📍 Increased ARPU from subscribers.
- 📍 New revenue streams.



A bouquet of 3G services



High quality voice

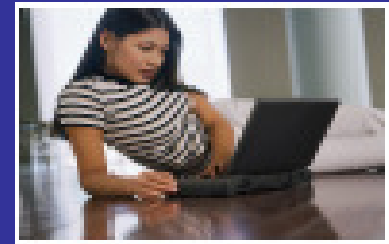

Mobile Broadband



Enhanced Content services – Music/tones/pictures

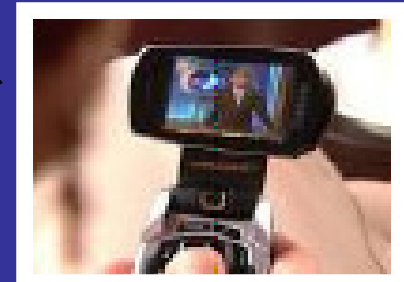

Video services Video Call/streaming videos/ Video clips

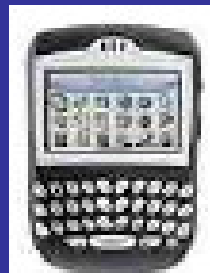

Business solutions E-Mail/enterprise services

Mobile TV



Mobile TV allows the user to view TV channels on the mobile

Enhanced contents & services

The content services include the following:

- Full movie /music download
- Live news & sport updates
- Interactive games
- Video streaming
- Wallpapers and
- Tone downloads



Full track music download

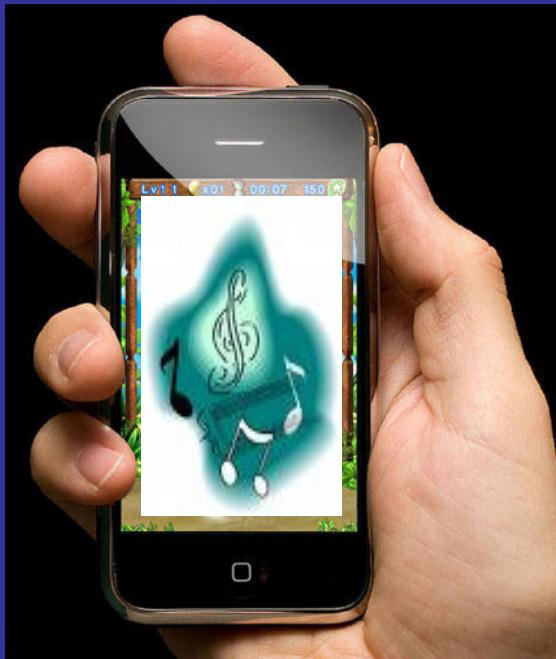

Users can download full track music and videos on their mobile any time , any where

Mobile Broadband

This has happened:

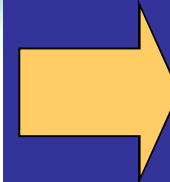
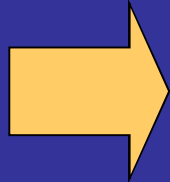

This is happening now:

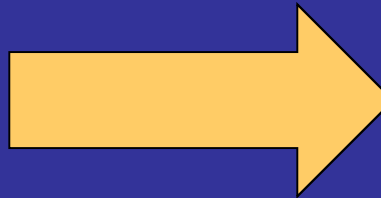

NEXT 

Mobile Broadband

📡 Mobile Broadband signifies

- High speed
- Wireless access

📡 Access devices like a portable laptop or a mobile handset are typically used.

📡 3G gives the user the flexibility to access high speed internet any time anywhere.



Video Based Services

Video Call

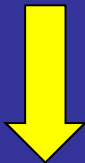

With the deployment of 3G, Video call service will put BSNL on clear cut advantageous position with respect to it's competitors

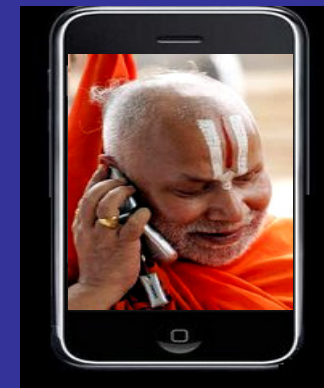

NEXT

Video Based Services

Video Call



A girl in a city looking and talking to her grandmother, living in a rural area, through 3G Phone

NEXT 

Video Based Services

Video Mail

In addition to voice mail available on 2G platform, with 3G we can deploy video mail service also



NEXT 

Video Based Services

Video Conferencing



With 3G Technology we can have video conferencing facility through our mobile phones

For Different Customer Segments



ring tone

music



sport

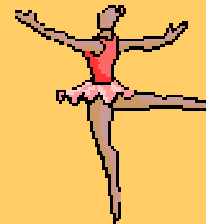

game

news



chat



Diverse Content requirement across segments

Teens

Demographic Profile

- Age 5-15 years
- Still in School
- Belonging to High income group

Attitude to Technology

- Like cutting edge technology
- Use mobile phone as a personal statement



Target Services

Instant Messaging
Video calls
Music Downloads
MMS

NEXT →

Diverse Content requirement across segments

Youth

Demographic Profile

- Age 15-24 years
- Mix of college-going and working
- Belonging to medium to High income group



Attitude to Technology

- Like new technology
- Heavy user of telecom services for socializing
- Emphasis on design brand and new features to show off.

Target Services

- Interactive Game
- Video calls
- Music Downloads
- See Me TV, Mobile TV
- Mobile Blogging

NEXT 

Diverse Content requirement across segments

Professional

Demographic Profile

- Age 25-54 years
- Graduate & Post Graduate
- Salaried & self employed people with medium to higher salary

Attitude to Technology

- Needed for productivity improvement
- Fashion and status improvement
- Emphasis on design brand and new features to show off.



Target Services

- Mobile Banking / Mobile Trading
- Video calls / Video surveillance
- Video on Demand / Mobile TV
 - Location based services/
High Speed internet

NEXT 

Diverse Content requirement across segments

Adult

Demographic Profile

- Age 25-54 years
- Graduate & Post Graduate
- Blue collared workers
- Low to medium salary

Attitude to Technology

- Slow to adoption to new technology
- Uses technology if it has quantitative benefits in their lives



Target Services

- Email
- Bill Payment
- Location based services

NEXT 

Diverse Content requirement across segments

Seniors

Demographic Profile

- Age 54 years and above
- Retired and home makers
- Low to medium salary

Attitude to Technology

- Often scared to new technology
- Feels stressed out and less in control while using the technology



Target Services

- Email
- Bill Payment
- music download
- Video call

Key Success Factors

Mobile TV

- Getting the right (most attractive) content providers (TV Channels) is vital.
- Easy service enablement for customers.



NEXT 

Key Success Factors

Mobile Sports Clips

- Early-to-market with mobile video, rapid download.
- Content that appeals to many and that are willing to pay.
- Content that is updated regularly and has 'current' value.



Summary

- 3G is being introduced in India for the very first time
- Operators globally have used innovative strategies to lure 3G customers through varied content & pricing
- 3G services will be primarily used by high end customers who will expect high levels of customer support

Summary

- **3G services are inherently complex in nature. So subscribers are bound to have lot of queries on 3G services. Role of customer care is crucial for the success of 3G services**
- **Service adoption will ultimately be driven by the level of preparedness and drive of the customer interacting team**

