



Easy Fuel™ "no cap" Fuel Filler

November 12, 2007

Easy Fuel™ “no cap” Fuel Filler

Introduction

Starting in late November, 2007 all Ford Explorer (except Sport Trac) and Mercury Mountaineer models will be equipped with the Easy Fuel™ “no cap” fuel filler system. This new feature eliminates the need for a fuel filler cap and allows the driver to simply insert the fuel nozzle. When fueling is completed, removing the nozzle causes the spring-loaded fuel filler to close and latch, preventing fuel vapors from escaping in to the atmosphere.

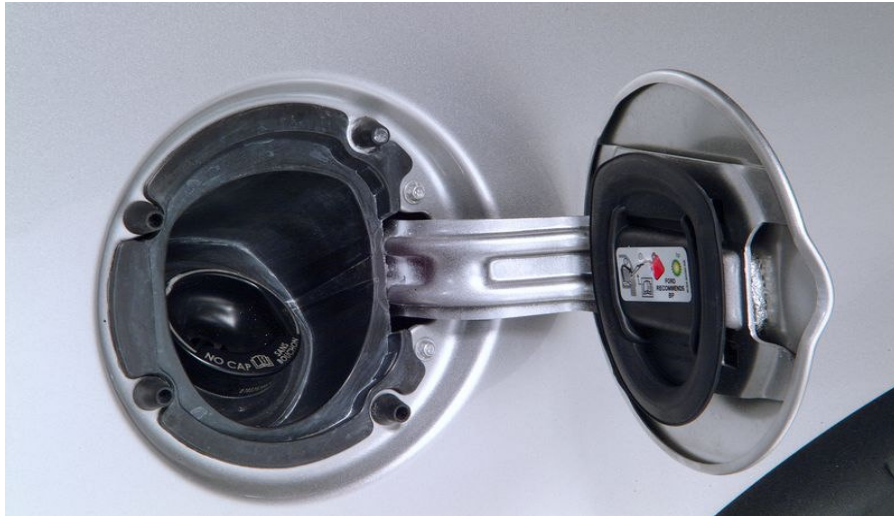

Figure 1. Easy Fuel™ Fuel Filler

How It Works

The spring loaded fuel door is held closed by two latches (Figures 2 and 3.), which can only be released by a standard size unleaded fuel nozzle, or the special plastic funnel included with the vehicle. Use of the funnel will be covered later.

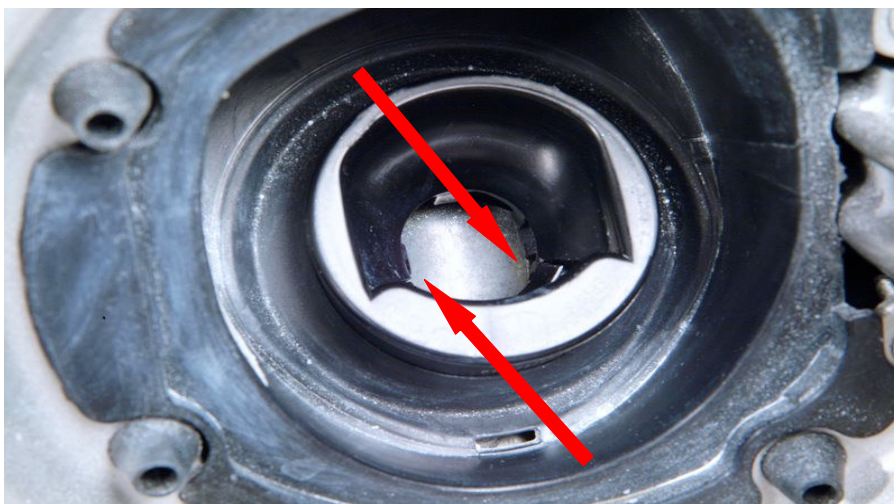

Figure 2. Fuel Door Latches, Exterior View

Easy Fuel™ “no cap” Fuel Filler

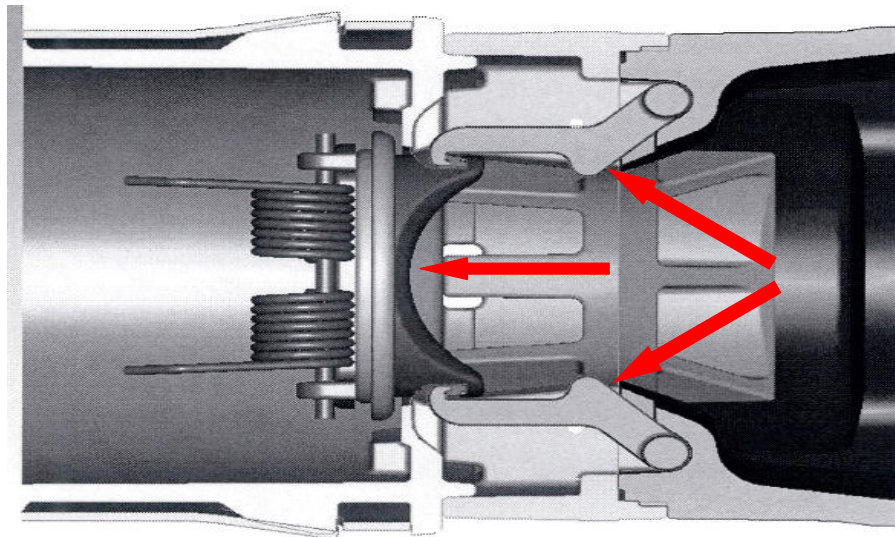

Figure 3. Cutaway View of Fuel Door and Latches

When the proper fuel nozzle is inserted into the filler neck (Figure 4.), the latches are released and the nozzle pushes the spring-loaded filler door to the open position. When the nozzle is removed, the fuel door is forced closed by the spring. The fuel filler is completely sealed to prevent the escape of fuel vapors.

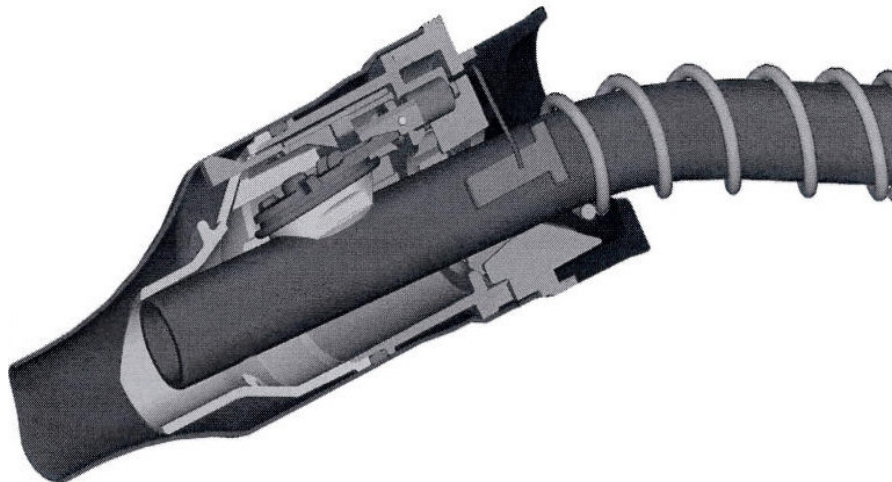

Figure 4. Cutaway View of Fuel Nozzle Inserted in the Filler Neck

Easy Fuel™ “no cap” Fuel Filler

If a fuel nozzle of a different size, such as diesel or a funnel is placed in the filler neck, the nozzle will be unable to release the latches (Figure 5.). This prevents accidental misfueling of the vehicle or tampering, such as siphoning of the fuel tank.

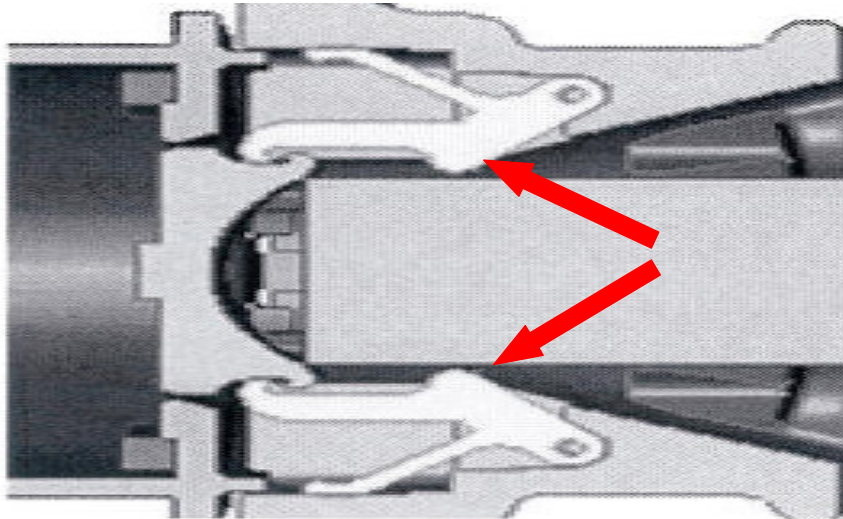

Figure 5. Incorrect Fuel Nozzle Inserted, Latches Not Released

Preventing Contamination

A flexible rubber seal, attached to the outer fuel filler door, seals the fuel filler to help prevent dirt, snow or rain from entering the fuel filler neck (Figure 6.). If the seal becomes damaged, it must be replaced to prevent possible contamination of the fuel tank. A pictogram on the seal reminds the owner to use the funnel, if fuel is being added from a portable fuel container.



Figure 6. Outer Fuel Filler Door Seal

Easy Fuel™ “no cap” Fuel Filler

Adding Fuel from a Portable Fuel Container

In the event you need to add fuel from a portable fuel container, you will need to use the following procedure. Do not insert the nozzle of portable fuel containers (Figure 7.) or aftermarket funnels into the Easy Fuel™ system. This could damage the fuel system and its seal and cause injury to you or others. Do not try to pry open or push open the Easy Fuel™ system with foreign objects. This could damage the fuel system and its seal and cause injury to you or others.



Figure 7. Do Not Attempt Adding Fuel Without the Provided Funnel

When filling the vehicle's fuel tank from a portable fuel container, you will need to use the white plastic funnel included with your vehicle. It is the same diameter as an unleaded fuel nozzle and is located in the cargo bin, behind that last row of seats and is attached to the cover on the tire changing tools (Figure 8.).

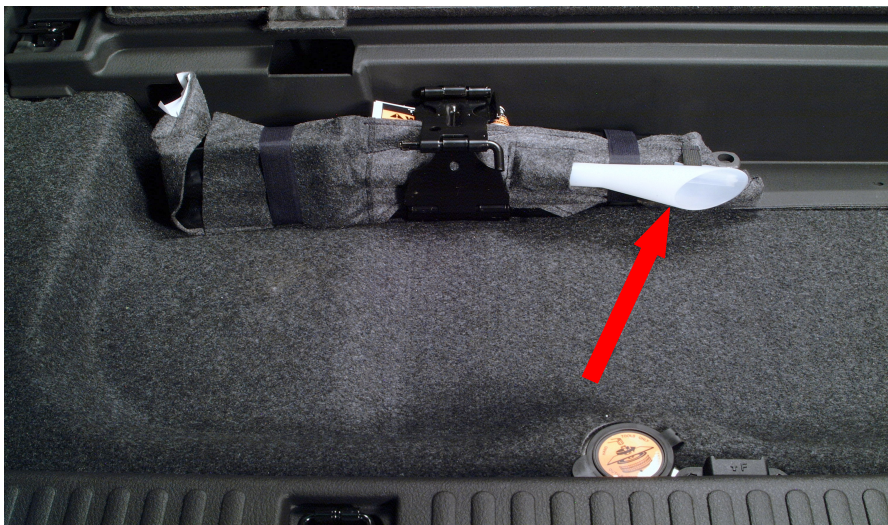

Figure 8. Fuel Funnel Location in Storage Bin

Easy Fuel™ “no cap” Fuel Filler

Fully insert the funnel into the fuel filler neck (Figure 9.). Add fuel from the portable container (Figure 10.) and return the funnel to the storage bin for future use. If the funnel is lost, you may purchase a replacement at any Ford or Lincoln Mercury Dealer. Service Part No. 8U5Z-17B068-B

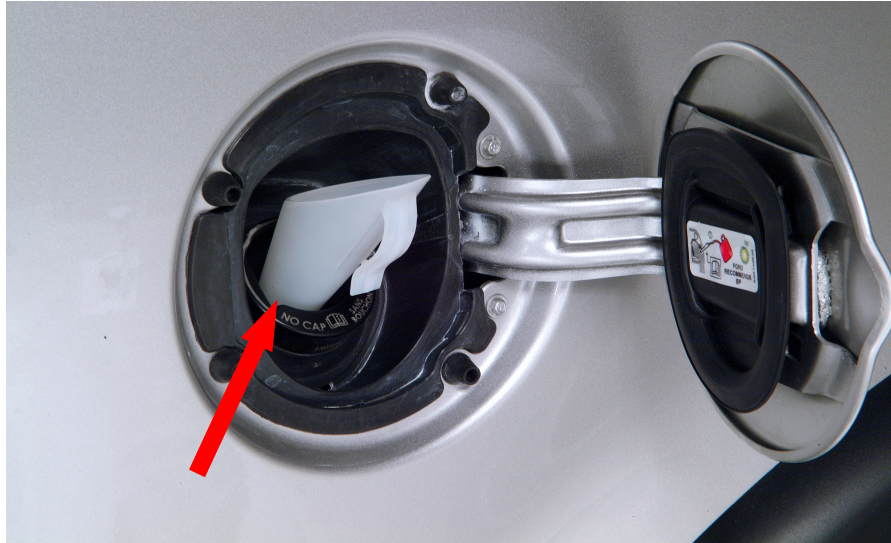

Figure 9. Fuel Funnel Inserted in Filler Neck



Figure 10. Adding Fuel from a Portable Container

Easy Fuel™ “no cap” Fuel Filler

Warning Lamp/Message Center

If the Check Fuel Fill Inlet lamp or Check Fuel Fill Inlet message comes on, the fuel fill inlet may not have properly closed. The inlet may have stuck open or debris may be preventing the inlet from fully closing. At the next opportunity, safely pull off the road, turn off the engine, open the fuel filler door and remove any visible debris from the fuel fill opening. Insert either the fuel fill nozzle or the fuel fill funnel provided with the vehicle several times to dislodge any debris and/or allow the inlet to close properly. If this action corrects the problem, the Check Fuel Fill Inlet lamp or Check Fuel Fill Inlet message may not reset immediately. It may take several driving cycles for the Check Fuel Fill Inlet lamp or Check Fuel Fill Inlet message to turn off. A driving cycle consists of an engine start-up (after four or more hours with the engine off) followed by city/highway driving. Continuing to drive with the Check Fuel Fill Inlet lamp or Check Fuel Fill Inlet message on may cause the Service Engine Soon lamp to turn on as well. The fuel system may be under pressure. Insert the fuel filler nozzle slowly; otherwise, fuel may spray out and injure you or others.

Using a Locking Fuel Filler Plug

A locking fuel filler plug is being developed as an accessory (Figures 11 and 12.). This device fits into the fuel filler neck opening and locks with a turn of the key to provide added security from fuel theft. Availability of the plug will be announced at a later date. Go to; www.fordaccessoriesstore.com for availability updates.



Figure 11. Accessory Locking Fuel Filler Plug

Easy Fuel™ “no cap” Fuel Filler



Figure 12. Locking Fuel Filler Plug Installed

More Information

Complete information about the Easy Fuel™ “no cap” fuel filler is included in the Owner’s Guide (Figure 13.) under the “Adding Fuel” heading. In addition, you may direct questions about Easy Fuel™ to the Customer Relationship Center at: 800-392-FORD.

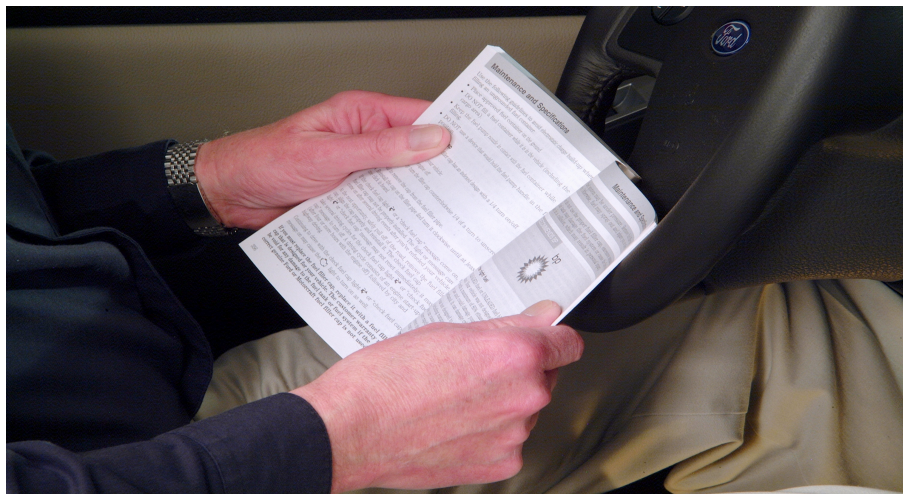

Figure 13. Owner's Guide

Service Department Information

The Easy Fuel™ “no cap” fuel filler requires no special tools and is diagnosed and serviced like any fuel filler using a conventional cap. All diagnostic information is contained within the Workshop Manual and PCED and tested with IDS or PDS. Refer to Section 310-01 of the Workshop Manual for more information.