

EcoSystem Multiple Control Input Ballasts

Digital electronic dimming ballasts maximize the benefits of a lighting management system. *EcoSystem* Ballasts offer 100% to 10% dimming; ideal for use where saving energy, increasing flexibility, and maximizing productivity are the goals of the lighting design.

Features

- Continuous, flicker-free dimming from 100% to 10%
- Provides power for and responds to one occupancy sensor, one photo sensor, and one personal control input (infrared receiver or wallstation)
- Communicates status and sensor inputs over the *EcoSystem* Bus
- Programmed rapid start design ensures full rated lamp life while dimming and cycling
- Lamps turn on to any dimmed level without flashing to full brightness
- Low harmonic distortion throughout the entire dimming range
- Frequency of operation ensures that ballast does not interfere with infrared devices
- End-of-lamp-life protection circuitry ensures safe operation throughout entire lamp life
- Ultra-quiet operation
- Nonvolatile memory restores all ballast settings after power failure
- Ballasts maintain consistent light output for linear lamp lengths (i.e. 4 ft., 3 ft., 2 ft. have same relative output)
- 100% performance tested at factory



EcoSystem case type G

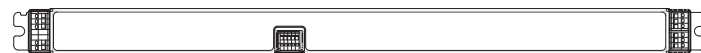

EcoSystem case type J

<p>Job Name:</p> <p>Job Number:</p>	<p>Model Numbers:</p>
--	------------------------------

Specifications

Standards

- California Energy Commission (CEC) Listed
- UL Listed (evaluated to the requirements of UL935)
- CSA certified (evaluated to the requirements of C22.2 No. 74)
- NOM Listed for 32 W T8 Ballasts
- S Mark Certified
- Class P thermally protected
- Meets ANSI C82.11 High Frequency Ballast Standard
- Meets FCC Part 18 Non-Consumer requirements for EMI/RFI emissions
- Meets ANSI C62.41 Category A surge protection standards up to and including 4 kV
- Manufacturing facilities employ ESD reduction practices that comply with the requirements of ANSI/ESD S20.20
- Lutron Quality Systems registered to ISO 9001.2000

Performance

- Operating Voltage: 120, 220/240, 277 V~ at 50 or 60 Hz
- Grounding: ballast and fixture must be grounded for proper dimming
- Dimming Range: 100% to 10% measured relative light output
- Lamp Starting: programmed rapid start
- Lamp Current Crest Factor: less than 1.7
- Light Output Variation: Constant $\pm 2\%$ light output for line voltage variations of $\pm 10\%$
- Lamp Life: Average lamp life meets or exceeds specified lamp ratings
- Power Factor: 0.95 minimum
- Total Harmonic Distortion (THD): Less than 20%
- Inaudible in a 27 dBA ambient
- Maximum Inrush Current: 3 A per ballast at 277 V~, 7A per ballast at 120 V~
- Class 2 Output: +20 V==, 50mA maximum (one daylight sensor, one keypad and one occupancy sensor can be connected)

Environment

- Minimum lamp starting temperature: 50 °F (10 °C)
- Relative humidity: less than 90% non-condensing
- Sound Rating: inaudible in a 27 dB ambient
- Maximum ballast case temperature: 75 °C (167 °F)

Ballast Wiring & Mounting







- Ballast is grounded by a mounting screw to the fixture
- Terminal blocks on the ballast accept the following wire gauges:
Power Wiring, Lamp Wiring, and *EcoSystem* Bus:
only one #18 AWG solid per terminal
Class 2 Sensors:
only one #22 AWG solid per terminal
- Only one wire per terminal
- Class 2 sensor wiring must be separated from all power and Class 1 wiring, consult all applicable local and national codes
- Ballast mounts using two screws (or sheet metal feature and one screw) within a fluorescent fixture
- Wiring from the ballast to lamp sockets shall not exceed 7 ft. for T8, T5, and T5HO lamps
- Wiring from the ballast to lamps sockets shall not exceed 3 ft. for T5 Twin Tube lamps

Lamp Seasoning

Refer to lamp manufacturer for lamp seasoning requirements prior to dimming





Job Name: Job Number:	Model Numbers:
--	-----------------------

EcoSystem Ballasts for linear and U bend T8 Lamps

Lamp	No. of Lamps	Model	Case Size	Input Voltage (VAC)	Input Current (A)	Input Power (W)	Ballast Factor (BF)	System Lumens (lm)	System Efficacy (lm/W)	Ballast Efficacy Factor	Relative Efficacy (RSE)
 F32T8 (48 in)	1	EC5 T832 J UNV 1	J	277	0.11	31.6	0.85	2550	81	2.69	0.86
				240	0.13	31.0	0.85	2550	82	2.74	0.87
				120	0.26	31.3	0.85	2550	81	2.72	0.87
	 2	EC5 T832 G UNV 2L	G	277	0.22	59.6	0.85	5100	86	1.43	0.91
				240	0.25	57.6	0.85	5100	89	1.48	0.94
				120	0.49	58.8	0.85	5100	87	1.45	0.93
		EC5 T832 J UNV 2	J	277	0.21	57.4	0.85	5100	89	1.48	0.95
				240	0.25	59.0	0.85	5100	86	1.44	0.92
				120	0.49	59.1	0.85	5100	86	1.44	0.92
	3	EC5 T832 G UNV 3L	G	277	0.31	86.5	0.85	7650	88	0.98	0.94
				240	0.36	84.0	0.85	7650	89	1.01	0.97
	EC5 T832 G UNV 317L	G	277	0.41	105.7	1.17	10,530	100	1.11	1.06	
240			0.47	106.5	1.17	10,530	99	1.10	1.05		
120	0.95	106.8	1.17	10,530	99	1.10	1.05				
 F25T8 (36 in)	1	EC5 T825 J UNV 1	J	277	0.10	27.6	0.85	1828	66	3.08	0.77
				240	0.11	27.0	0.85	1828	68	3.15	0.79
				120	0.23	26.9	0.85	1828	68	3.16	0.79
	 2	EC5 T825 J UNV 2	J	277	0.18	48.9	0.85	3665	75	1.74	0.87
				240	0.20	49.0	0.85	3665	75	1.73	0.87
				120	0.41	49.0	0.85	3665	75	1.73	0.87
 F17T8 (24 in)	1	EC5 T817 J UNV 1	J	277	0.08	20.6	0.85	1190	68	4.13	0.70
				240	0.08	20.0	0.85	1190	60	4.25	0.72
				120	0.17	20.1	0.85	1190	70	4.23	0.72
	 2	EC5 T817 J UNV 2	J	277	0.13	36.2	0.85	2380	66	2.35	0.80
				240	0.15	37.0	0.85	2380	64	2.30	0.78
				120	0.31	37.0	0.85	2380	64	2.30	0.78







Job Name:	Model Numbers:
Job Number:	

EcoSystem Ballasts for linear T5 Lamps

Lamp	No. of Lamps	Model	Case Size	Input Voltage (VAC)	Input Current (A)	Input Power (W)	Ballast Factor (BF)	System Lumens (lm)	System Efficacy (lm/W)	Ballast Efficacy Factor	Relative Efficacy (RSE)
F35T5 (57.1 in) 	1	EC5 T535 J UNV 1	J	277	0.15	42.0	1.0	3650	87	2.38	0.83
				240	0.18	42.3	1.0	3650	87	2.38	0.83
				120	0.35	42.2	1.0	3650	87	2.38	0.83
F28T5 (45.2 in) 	1	EC5 T528 J UNV 1	J	277	0.12	32.6	1.0	2900	89	3.07	0.86
				240	0.14	32.9	1.0	2900	88	3.04	0.85
				120	0.27	32.9	1.0	2900	88	3.04	0.85
	2	EC5 T528 J UNV 2	J	277	0.23	64.5	1.0	5800	90	1.55	0.87
				240	0.27	65.0	1.0	5800	89	1.54	0.86
				120	0.54	65.2	1.0	5800	89	1.53	0.86
F21T5 (33.4 in) 	1	EC5 T521 J UNV 1	J	277	0.09	25.8	1.0	2100	81	3.88	0.81
				240	0.12	25.8	1.0	2100	81	3.88	0.81
				120	0.22	25.8	1.0	2100	81	3.88	0.81
	2	EC5 T521 J UNV 2	J	277	0.17	46.0	1.0	4200	91	2.17	0.91
				240	0.20	47.2	1.0	4200	89	2.12	0.89
				120	0.39	47.2	1.0	4200	89	2.12	0.89
F14T5 (21.6 in) 	1	EC5 T514 J UNV 1	J	277	0.07	19.0	1.0	1350	71	5.26	0.74
				240	0.08	19.2	1.0	1350	70	5.21	0.74
				120	0.16	19.2	1.0	1350	70	5.21	0.74
	2	EC5 T514 J UNV 2	J	277	0.12	32.8	1.0	2700	82	3.05	0.85
				240	0.14	33.3	1.0	2700	81	3.00	0.85
				120	0.28	33.3	1.0	2700	81	3.00	0.85





Job Name:	Model Numbers:
Job Number:	

EcoSystem Ballasts for linear T5 HO Lamps

Lamp	No. of Lamps	Model	Case Size	Input Voltage (VAC)	Input Current (A)	Input Power (W)	Ballast Factor (BF)	System Lumens (lm)	System Efficacy (lm/W)	Ballast Efficacy Factor	Relative Efficacy (RSE)
F54T5 (45.2 in) 	1	EC5 T554 J UNV 1	J	277	0.21	56.5	1.0	5000	88	1.77	0.96
				240	0.24	58.0	1.0	5000	86	1.73	0.93
				120	0.48	57.9	1.0	5000	86	1.73	0.93
	2	EC5 T554 J UNV 2	J	277	0.40	110.1	1.0	10,000	91	0.91	0.98
				240	0.52	119.0	1.0	10,000	84	0.84	0.91
				120	0.99	119.3	1.0	10,000	84	0.84	0.91
F39T5 (33.4 in) 	1	EC5 T539 J UNV 1	J	277	0.16	43.3	1.0	3500	81	2.31	0.90
				240	0.18	44.0	1.0	3500	80	2.27	0.89
				120	0.37	44.0	1.0	3500	80	2.27	0.89
	2	EC5 T539 J UNV 2	J	277	0.30	83.0	1.0	7000	84	1.20	0.94
				240	0.35	84.0	1.0	7000	83	1.19	0.93
				120	0.70	84.3	1.0	7000	83	1.19	0.93
F24T5 (21.6 in) 	1	EC5 T524 J UNV 1	J	277	0.11	30.0	1.0	2000	67	3.33	0.80
				240	0.13	28.8	1.0	2000	69	3.47	0.83
				120	0.24	28.8	1.0	2000	69	3.47	0.83
	2	EC5 T524 J UNV 2	J	277	0.20	54.8	1.0	4000	73	1.82	0.89
				240	0.23	54.0	1.0	4000	74	1.85	0.89
				120	0.45	53.9	1.0	4000	74	1.86	0.89

Job Name:	Model Numbers:
Job Number:	

EcoSystem Ballasts for T5 Twin Tube Lamps

Lamp	No. of Lamps	Model	Case Size	Input Voltage (VAC)	Input Current (A)	Input Power (W)	Ballast Factor (BF)	System Lumens (lm)	System Efficacy (lm/W)	Ballast Efficacy Factor	Relative Efficacy (RSE)
FT55 (20.7 in)	1	EC5 T555 J UNV 1	J	277	0.20	55.4	0.9	4320	70	1.62	0.89
				240	0.23	55.2	0.9	4320	70	1.63	0.90
				120	0.46	55.2	0.9	4320	70	1.63	0.90
	2	EC5 T555 J UNV 2	J	277	0.40	110.8	0.9	8640	78	0.81	0.99
				240	0.46	110.4	0.9	8640	78	0.82	0.90
				120	0.92	110.4	0.9	8640	78	0.82	0.90
FT50 (22.5 in)	1	EC5 T550 J UNV 1	J	277	0.20	55.4	1.0	4000	72	1.81	0.90
				240	0.23	54.0	1.0	4000	72	1.85	0.93
				120	0.45	54.0	1.0	4000	74	1.85	0.93
	2	EC5 T550 J UNV 2	J	277	0.36	99.7	1.0	8000	80	1.00	1.00
				240	0.42	100.8	1.0	8000	79	0.99	0.99
				120	0.84	100.8	1.0	8000	79	0.99	0.99
FT40 (22.5 in)	1	EC5 T540 J UNV 1	J	277	0.16	44.3	1.0	3100	70	2.26	0.90
				240	0.18	43.2	1.0	3100	72	2.31	0.93
				120	0.36	43.2	1.0	3100	72	2.31	0.93
	2	EC5 T540 J UNV 2	J	277	0.27	74.8	1.0	6200	83	1.34	1.07
				240	0.32	76.8	1.0	6200	81	1.30	1.04
				120	0.64	76.8	1.0	6200	81	1.30	1.04
	3	EC5 T540 G UNV 3L	G	277	0.40	111.3	1.0	9300	84	0.90	1.08
				240	0.47	112.4	1.0	9300	83	0.89	1.07
				120	0.95	113.2	1.0	9300	82	0.88	1.06
FT39 FT36 (15.5 in)	1	EC5 T536 J UNV 1	J	277	0.14	38.8	1.0	2850	74	2.57	0.93
				240	0.17	39.6	1.0	2850	72	2.53	0.91
				120	0.33	39.6	1.0	2850	72	2.53	0.91
	2	EC5 T536 J UNV 2	J	277	0.26	72.0	1.0	5700	79	1.39	1.00
				240	0.31	73.2	1.0	5700	78	1.37	0.98
				120	0.61	73.2	1.0	5700	78	1.37	0.98

Job Name:	Model Numbers:
Job Number:	

EcoSystem Ballast Case Dimensions

G Case

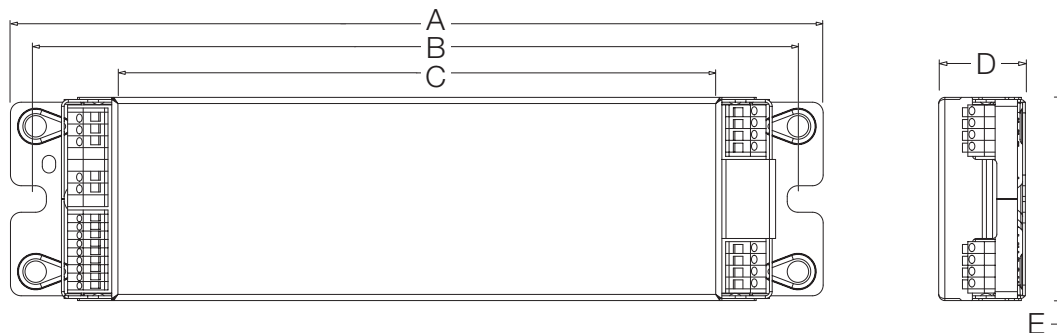

G Case Dimensions

- A = 9.5 in (241 mm)
- B = 8.9 in (226 mm)
- C = 7.1 in (180 mm)
- D = 1.0 in (25 mm)
- E = 2.38 in (60 mm)

G case ballasts ship with 36 in. leads for lamp connections and 18 in. leads for Hot, Neutral, E1 and E2 connections

J Case

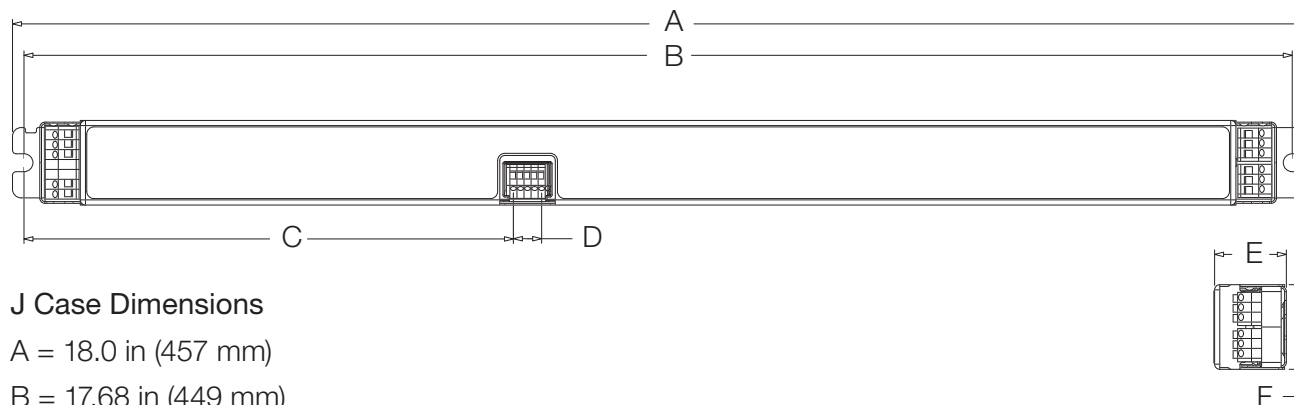

J Case Dimensions

- A = 18.0 in (457 mm)
- B = 17.68 in (449 mm)
- C = 6.82 in (173 mm)
- D = .394 in (10 mm)
- E = 1.0 in (25 mm)
- F = 1.18 in (30 mm)

Job Name:	Model Numbers:
Job Number:	

EcoSystem Ballast Wiring Diagrams - T8, T5, T5 HO

Wiring to One Lamp (J case shown)

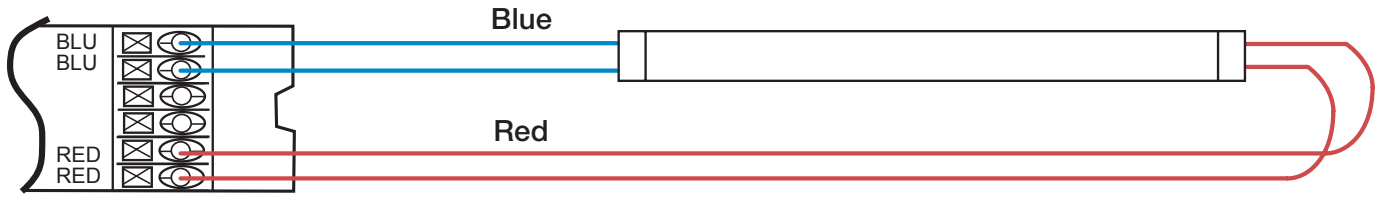

Wiring to Two Lamps (J case shown)

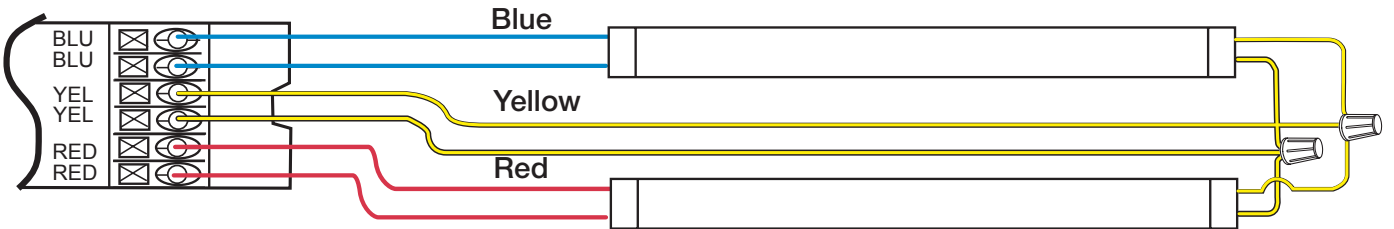

Wiring to Two Lamps (G case shown)

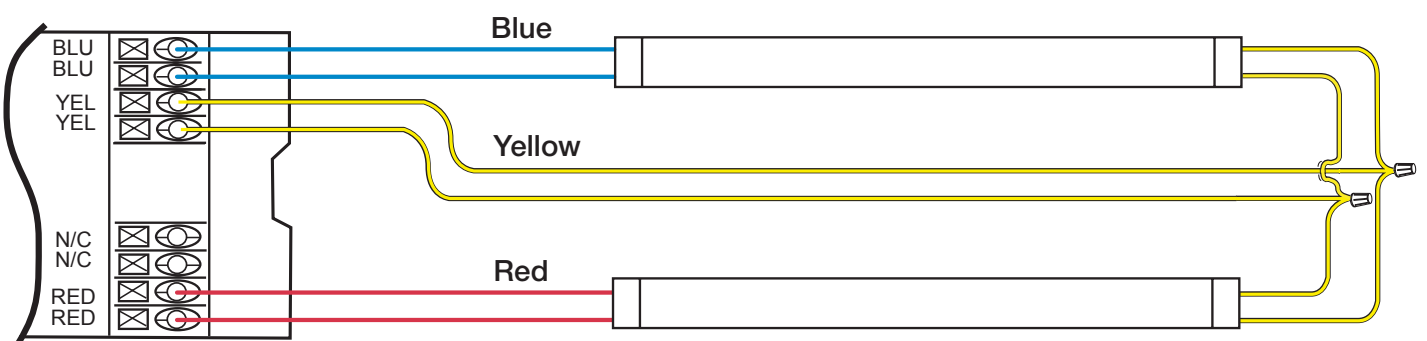

Wiring to Three Lamps (G case shown)

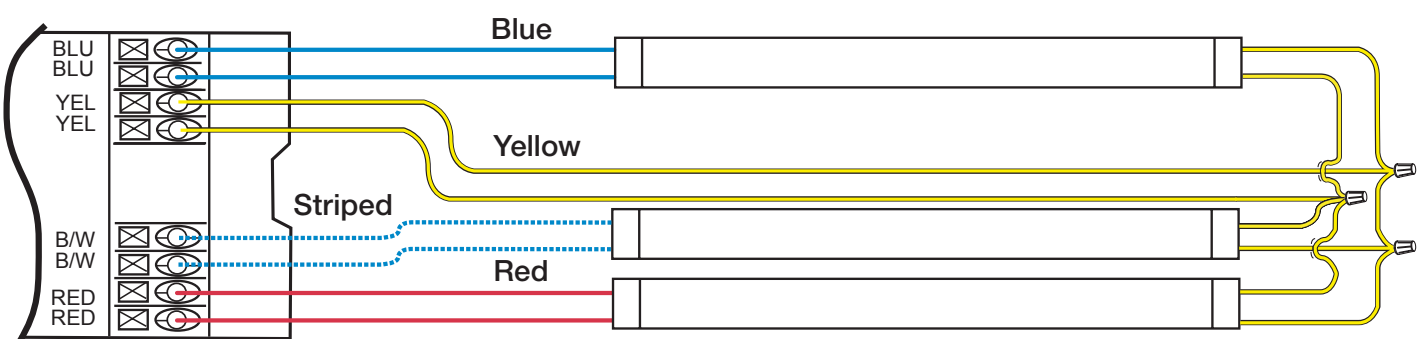

NOTICE

- Maximum ballast to lamp socket lead length is 7 feet (2 m)
- Wire colors shown are labeled on the ballast, but may vary depending upon fixture construction

Job Name:	Model Numbers:
Job Number:	

EcoSystem Ballast Wiring Diagrams - T5 Twin-Tube

Wiring to One Lamp

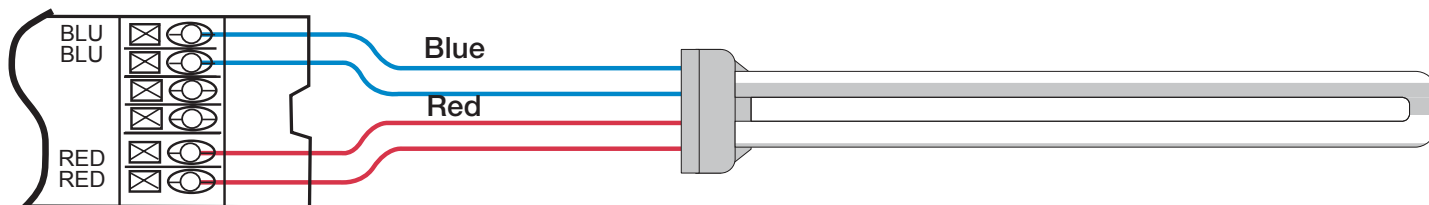

Wiring to Two Lamps

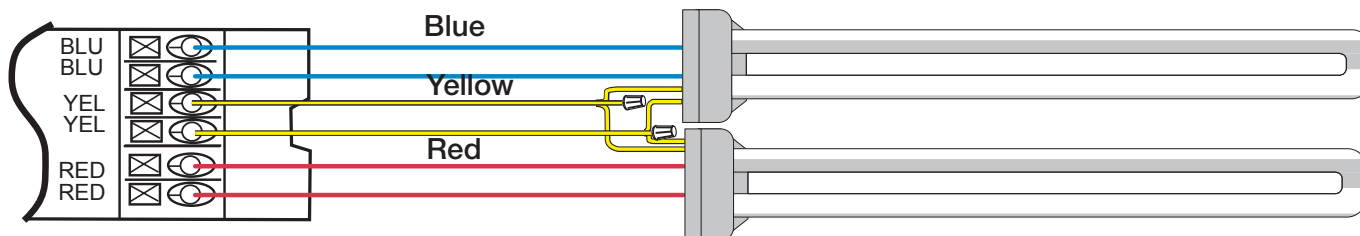

NOTICE

- Maximum ballast to lamp socket lead length is 3 feet (1 m)
- Wire colors shown are labeled on the ballast, but may vary depending upon fixture construction

Job Name:	Model Numbers:
Job Number:	

EcoSystem Ballast Wiring: EcoSystem Bus

EcoSystem Bus Overview

- The *EcoSystem* Bus wiring (E1 and E2) connects the digital ballasts together to form a lighting control system
- Each *EcoSystem* Bus supports up to 64 digital ballasts, 32 occupant sensors, 8 daylight sensors, and 64 wallstations or IR receivers
- E1 and E2 (*EcoSystem* bus wires) are polarity insensitive and can be wired in any topology
- An *EcoSystem* Bus Supply provides power for the *EcoSystem* Bus and supports system programming
- All *EcoSystem* Bus programming is completed by using the *EcoSystem* Programmer

EcoSystem Bus Wiring

- Ballast *EcoSystem* Bus terminals only accept one #18 AWG solid wire
- Make sure that the supply breaker to the Digital Ballast and *EcoSystem* Bus Supply is OFF when wiring
- Connect the two conductors to the two Digital Ballast terminals E1 and E2 as shown
- Using two different colors for E1 and E2 will reduce confusion when wiring several ballasts together
- The *EcoSystem* bus may be wired Class 1 or Class 2. Consult applicable electrical codes for proper wiring practices

Notes

- The *EcoSystem* Bus Supply does not have to be located at the end of the Digital Loop
- E1 and E2 wires are not polarity sensitive
- *EcoSystem* Bus length is limited by the wire gauge used for E1 and E2 as follows:

Wire Gauge	Bus Length (max)
12 AWG	2200 ft (670 m)
14 AWG	1400 ft (427 m)
16 AWG	900 ft (274 m)

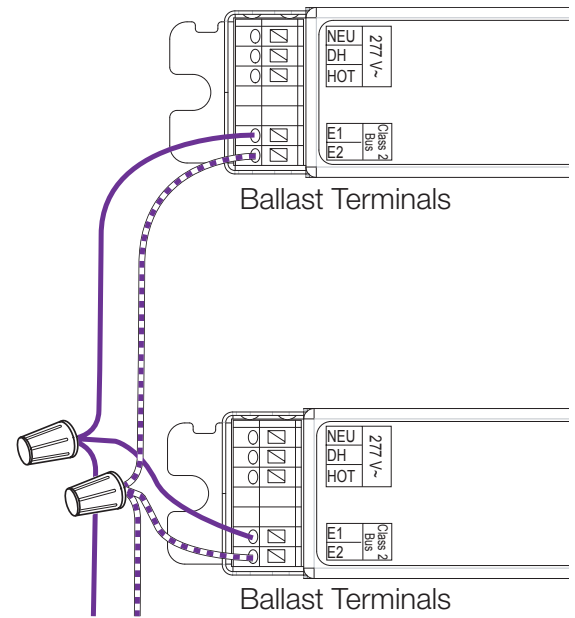

To the *EcoSystem* Bus Supply & up to 64 total ballasts

Job Name:	Model Numbers:
Job Number:	

EcoSystem Ballast Wiring: Class 2 Sensors

Electrical Contractors and Engineers:

- Always follow applicable national and local electrical code requirements when connecting circuits to *EcoSystem* devices
- All field installed Class 2 wiring must be separated from line voltage wiring by at least 0.25 in. (6.4 mm)
- Some local electrical codes require Class 2 wiring to be separately routed in a metal conduit
- Ballasts Class 2 Sensor terminals only accept 22 AWG solid conductors

Lutron Requires:

- Keep class 1 and class 2 wiring separate.
- Where separation is not possible, use a 600 V insulated cable with an internal shield. Connect the shield to ground to provide better noise immunity for low voltage circuits
- Refer to Application note #142 for additional information

Fixture Manufacturers:

- UL 1598 6.17.1 allows:
Factory installed power limited wiring and branch circuit wiring that come in random contact within the luminaire shall have insulation rated for the maximum voltage that exists in any of the circuits. (*EcoSystem* ballast circuits require minimum 600 V insulated wire)
- UL 1598 6.17.2.1 requires:
Luminaires designed for the field installation of power limited circuits shall be provided with a means of segregating or separating the field-installed power limited circuit wiring from the branch circuit wiring within the luminaire (see UL 1598 6.17 for details)

Lutron Requires:

- Keep class 1 and class 2 wiring separate
- Where separation is not possible, use a 600 V insulated cable with an internal shield. Connect the shield to ground to provide better noise immunity for low voltage circuits

<p>Job Name:</p> <p>Job Number:</p>	<p>Model Numbers:</p>
--	-----------------------

EcoSystem Ballast Wiring: Daylight Sensor

Wiring to a Daylight Sensor

- Sensor wiring summary:

Sensor Wire	Ballast Terminal	Terminal Color
Red	+20 V===	Red
Black	Common	Black
White	IR	White
Yellow	Daylight	Yellow

- Make sure that the supply breaker to the Digital Ballast is OFF when wiring.
- Connect the four conductors to the four Digital Ballast terminals as shown.
- Daylight sensor must be placed within 50 feet (15 m) of the ballast.
- Ballast Class 2 terminals only accept one 22 AWG solid wire.

Notes

- Consult the daylight sensor specification sheet to properly locate the sensor.
- Do not place the sensor above pendant fixtures, directly below lighting fixtures, or within skylight wells.
- When wiring both a wallstation and daylight sensor to one ballast, only connect the IR wire (white) from the keypad, cap off the white wire from the daylight sensor.
- All sensor and wallstation wiring is Class 2. Follow all applicable national and local codes for proper circuit separation and protection.

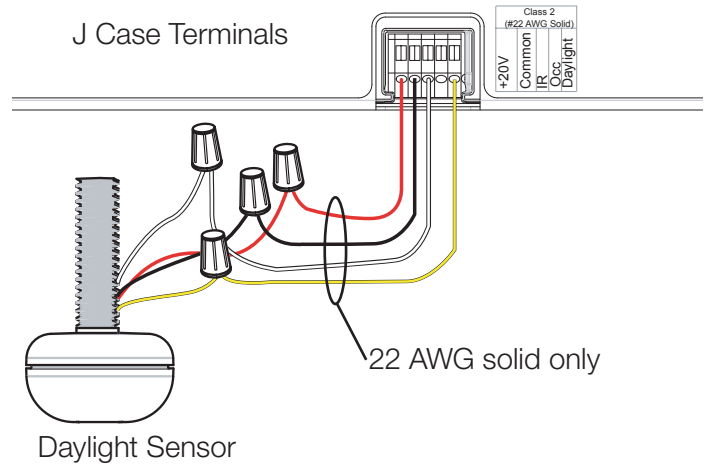
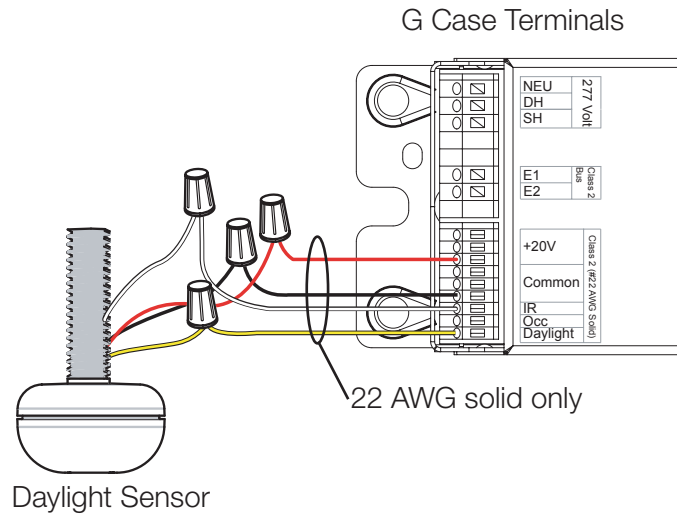

Job Name:	Model Numbers:
Job Number:	

EcoSystem Ballast Wiring: Occupancy Sensor

Wiring to a Lutron Occupant Sensor (LOS-XX)

- Sensor wiring summary:

Sensor Wire	Ballast Terminal	Terminal Color
Red	+20 V _{DC}	Red
Black	Common	Black
Blue	Occ	Blue

- Make sure that the supply breaker to the Digital Ballast is OFF when wiring
- Connect the three conductors to the three ballast terminals as shown
- Occupant sensor must be placed within 50 feet (15 m) of the ballast
- Ballast Class 2 terminals only accept one 22 AWG solid wire

Notes

- Occupant sensors from other manufacturers may be used with *EcoSystem* ballasts if the sensor meets the following criteria:
 $V_{in} = +20 V_{DC}$, current draw less than 35 mA
- If other manufacturer's occupant sensors are used terminal colors and sensor wire colors may not match
- All sensor and wallstation wiring is Class 2. Follow all applicable national and local codes for proper circuit separation and protection.

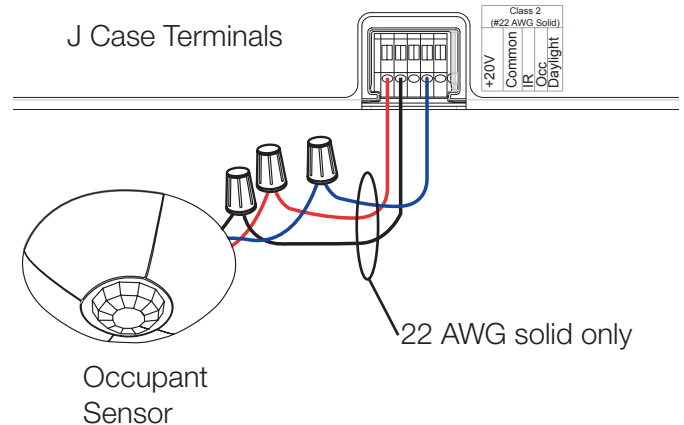
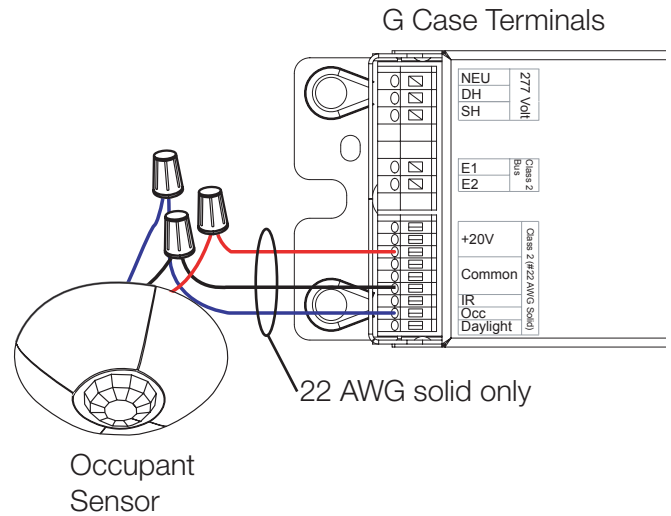

Job Name:	Model Numbers:
Job Number:	

EcoSystem Ballast Wiring Diagrams (continued)

Wiring to an IR Receiver and Wallstation

- Wiring summary:

Sensor Wire	Ballast Terminal	Terminal Color
Red	+20 V===	Red
Black	Common	Black
White	IR	White

- Make sure that the supply breaker to the Digital Ballast is OFF when wiring
- Connect the three conductors to the three Digital Ballast terminals as shown
- Receiver must be placed within 50 feet (15 m) of the ballast
- Ballast Class 2 terminals only accept one 22 AWG solid wire

Notes

- Only one wallstation or IR receiver can be wired to a digital ballast
- If a daylight sensor and wallstation/IR receiver are connected to one ballast, do not connect the daylight sensor's IR output
- All sensor and wallstation wiring is Class 2. Follow all applicable national and local codes for proper circuit separation and protection.

G Case Terminals

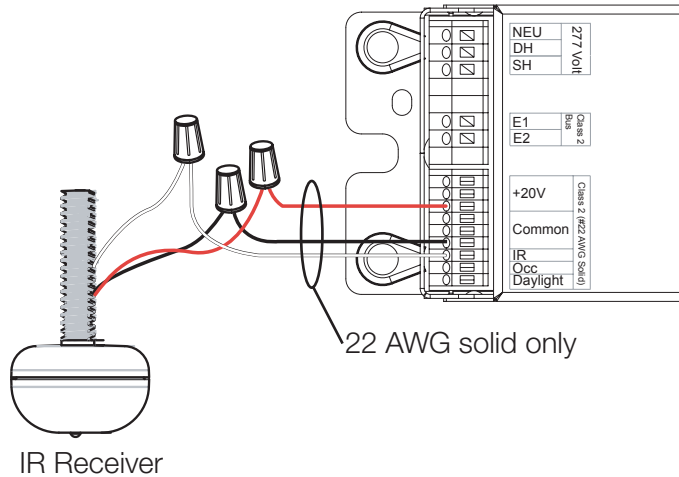

J Case Terminals

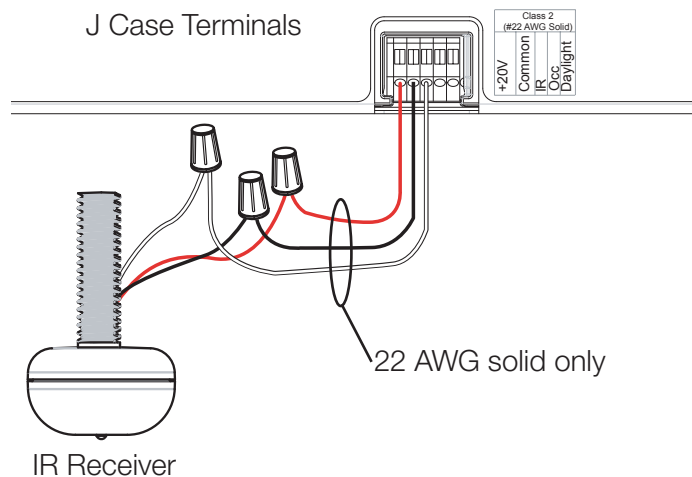

Wires to Digital Ballast

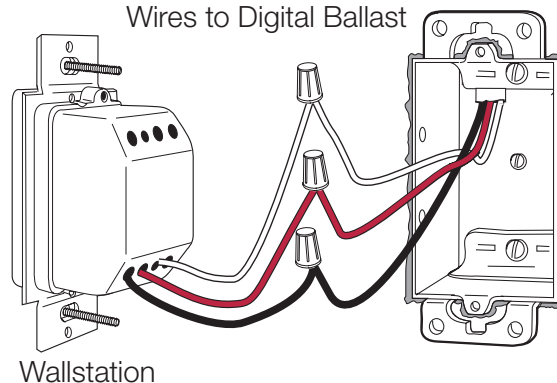

Job Name:	Model Numbers:
Job Number:	

EcoSystem Ballast Wiring: Multiple Devices

Multiple Sensors with One Ballast

- EcoSystem ballasts accept wiring for one daylight sensor input, one occupant sensor input and one IR input (wallstation or IR receiver)
- EcoSystem daylight sensors have IR outputs that allow the device to operate as a programming port. In applications where a daylight sensor and wallstation are wired to the same ballast, do not connect the white wire of the daylight sensor to the ballast. The wallstation operates as the programming port through its integral IR receiver
- Use the chart below as a guide for wiring multiple devices to a ballast

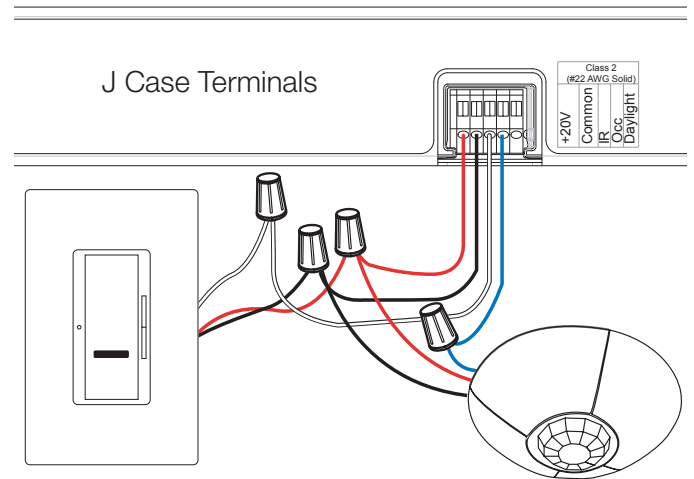

How to Use the Chart

Connect a sensor to a ballast from the “Devices” column (in bold). Along the selected device row, are “Y’s” and “N’s”. Where a “Y” is placed, the device at the top of that column can also be connected to the same ballast. An “N” indicates no connection allowed.

Devices	Daylight sensor (with IR)	Occupant sensor	Wallstation or IR receiver	Daylight Sensor (no IR)
Daylight sensor (with IR)	\	Y	N	N
Occupant sensor	Y	\	Y	Y
Wallstation or IR Receiver	N	Y	\	Y
Daylight sensor (no IR)	N	Y	Y	\

Example: When a Daylight Sensor with its internal IR are connected to a ballast, then only an occupancy sensor can be added for the system to properly function.

Job Name:	Model Numbers:
Job Number:	

EcoSystem Ballast Wiring: Line Voltage Dimmers

EcoSystem Ballasts and 3-wire dimmers

- Lutron 3-wire dimmers only control the ballast they are wired to; *EcoSystem* does not support grouping of 3-wire control input.

3-Wire Control Wiring

- Make sure that the supply breaker to the Digital Ballast is OFF when wiring.
- Wire as shown

Line input	Connects to
Hot	Dimmer Black Wire
Neutral	Dimmer White Wire

Dimmer wire	Connects to
Yellow	Ballast Orange (DH)
Red	Ballast Black (HOT)
White	Ballast White (NEU)
Green	Earth Ground

- *EcoSystem* ballast line voltage and 3-wire input terminals only accept one 18 AWG solid wire.

Emergency and 3-wire

- *EcoSystem* ballasts controlled by a wallbox dimmer should not be used for emergency/egress lighting unless an external emergency ballast is used in the fixture. See Lutron Ap. Note #50.
- *EcoSystem* ballasts may be used for emergency/egress lighting when controlled by a Lutron dimming panel (GP); where the panel is a dedicated emergency panel.

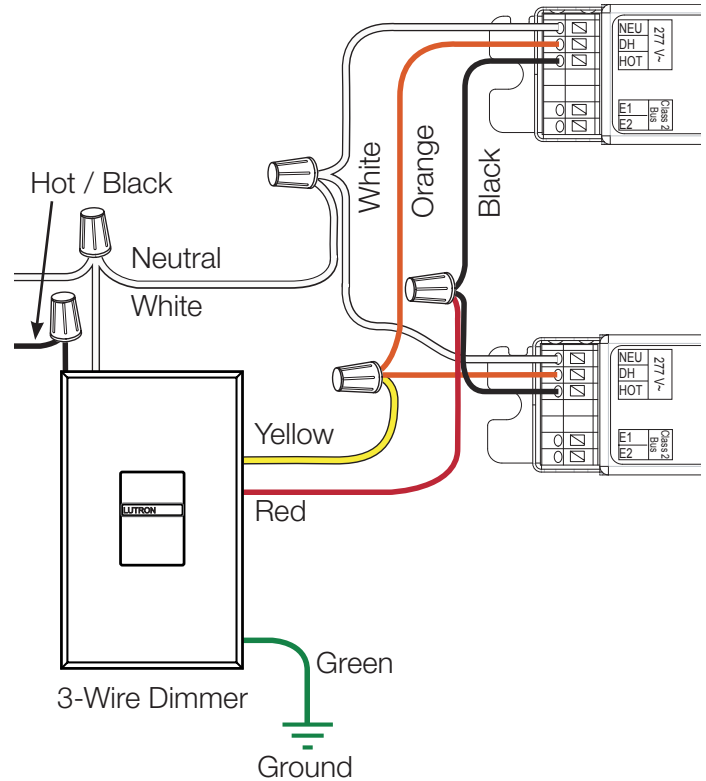

Notice

3-Wire control turns off digital ballasts when the control is in the off position. The digital ballast inputs: daylight sensor, wallstation, occupant sensor, and IR receiver will not function when the digital ballast is turned off

Job Name:	Model Numbers:
Job Number:	

Attention Electricians and Fixture Manufacturers

Ballast/Socket Leads

Lead lengths from ballast to socket must not exceed 7 feet (2 m) for linear lamps (T5, T5HO, T8). Lead lengths must not exceed 3 feet (1 m) for T5 twin tube lamps.

Lamp Sockets

Lamp sockets as per IEC 60400 are required to ensure positive lamp-pin to socket contact.

Mounting for T5 and T5HO Lamps

Mount lamps 3/8 in. ± 1/8 in. away from the grounded metal surface.

Mounting for T8 & T5 Twin Tube Lamps

Mount lamps 1/2 in. ± 1/4 in. away from the grounded metal surface.

Having a lamp too close to the grounded metal will reduce lamp life. Having a fluorescent lamp too far away from the grounded metal will make the lamp flicker or not turn on at all.

Lamp Seasoning Requirements

Some fluorescent lamp manufacturers recommend that new fluorescent lamps be operated at full output (“seasoned”) before they can be dimmed, to render lamp impurities inert, ensuring proper dimming performance and average rated lamp life. Please contact your lamp manufacturer for seasoning requirements.

Further Information

For further information please visit www.lutron.com/ecosystem or contact our 24-hour Technical Support Center at 1-800-523-9466

<p>Job Name:</p> <p>Job Number:</p>	<p>Model Numbers:</p>
--	-----------------------