

**ED700 SYSTEM
INSTRUCTION MANUAL**

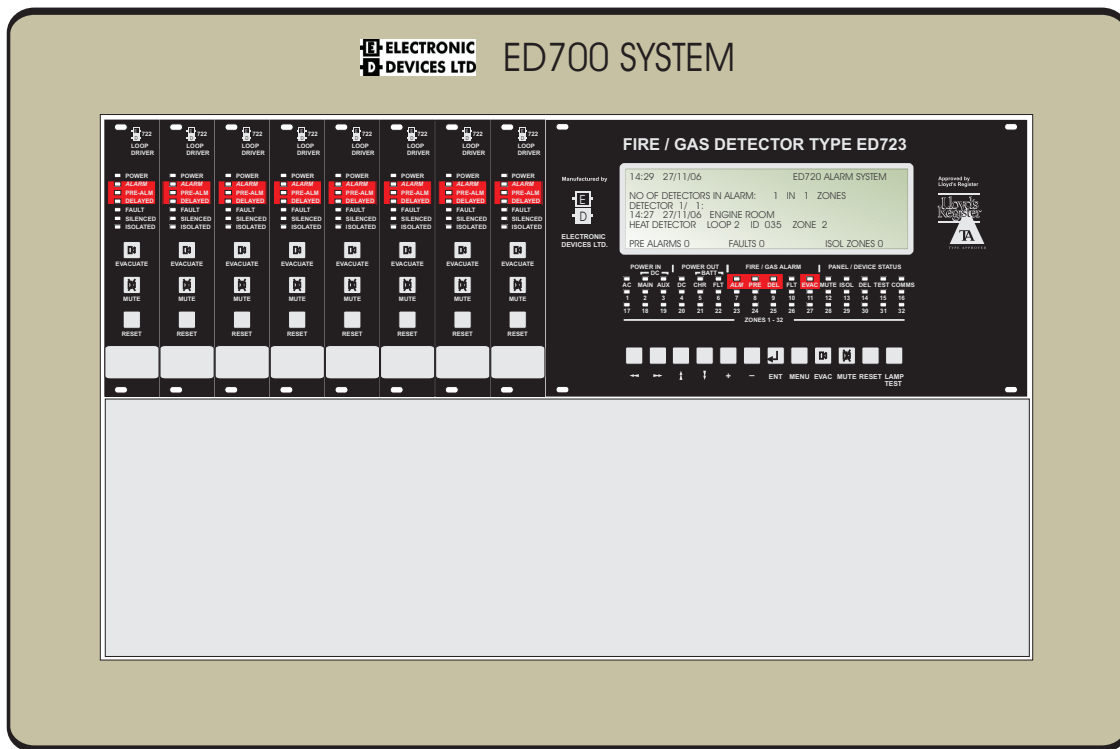

INDEX

<u>INTRODUCTION</u>	3		
<u>DESIGN, INSTALLATION & SETUP</u>		SECTION 7	
SECTION 1		Operating Instructions - quick guide	20
Component overview	4	Silencing sounders and beacons	20
ED722 and ED726 Loop Driver Module	4	System reset	20
ED723 Display Module	5	Evacuate	20
ED725 Input / Output Module	6		
SECTION 2		SECTION 8	
System design guidelines	7	Operating instructions	21
Loop lengths	7	Access levels	21
Loop loading	7	Switch on / Reboot screen	21
Loop cable selection	7	Main Menu	22
Loop cable resistance	7	History	22
Loop cable capacitance	8	Isolate / De-isolate	22
Screen continuity	8	System setup	23
Repeater cable selection	8	System setup - Walk through test	23
Power supply	8	System setup - Sounder Beacon test	23
		System setup - Search for new devices	24
SECTION 3		System setup - Set time and date	24
Control unit installation	9	System Menu	24
General	9	Gas Detection	24
ED700A I/O Module PCB connections	10	Delayed Alarms	25
Detector Base wiring diagrams	11	Reboot system	25
Sounder wiring diagram	11	Live values - System Voltages	25
Repeater wiring diagram	12	Live values - Head Values	26
		View faults	28
SECTION 4		View pre-alarms	28
Initial system setup	13	View isolates	28
PC based setup software (FireConfig.exe)	13		
SECTION 5		SECTION 9	
Cause and effect matrix	14	Fault messages	29
Important note	14	IO to loop cable fault	29
Maximum number of entries	14	Loop continuity fault	29
Adding cause and effect entries	15	No response from sensor	29
Auxiliary relay	16	Sensor internal fault	29
Sounders	16	Short circuit / Open circuit fault	29
Loop device - Sounders and beacons	16	Supply voltage fault	29
Loop device - Input Output modules	17	Communications fault	29
Delayed Outputs	17		
SECTION 6		SECTION 10	
Device types and configuration	18	Dual Redundancy	
XP95(A) North American models	18	Discovery Conventional Mode /	
Input Output modules / units	18	Hardware Fire Detection	30
Loop powered Sounders and Beacons	18		
Discovery Detectors	18		
Gas Detection	19		
Group Addressed Sounders / Beacons	19		
Master / Slave Sounders / Beacons	19		

INTRODUCTION

The ED700A Analogue Addressable Alarm system is capable of giving Fire, Gas, Water and/or Engine alarms, operate Fire Fighting equipment and is approved to Lloyds Register ENV1, 2, 3, 4 and 5.

It is capable of driving up to 1008 addressable devices per system in 8 loops of 126 devices per loop.

The ED700A has an enclosure 600 x 400 x 280mm weighing 30Kg and contains a mains PSU, batteries and all necessary electronics.

Built on standard Eurorack principles the ED700A allows for ease of maintenance. Contact Electronic devices limited on:

Tel: +44 (0)1684 891500

Fax: +44 (0)1684 891600

Email: info@electronicdevice.demon.co.uk

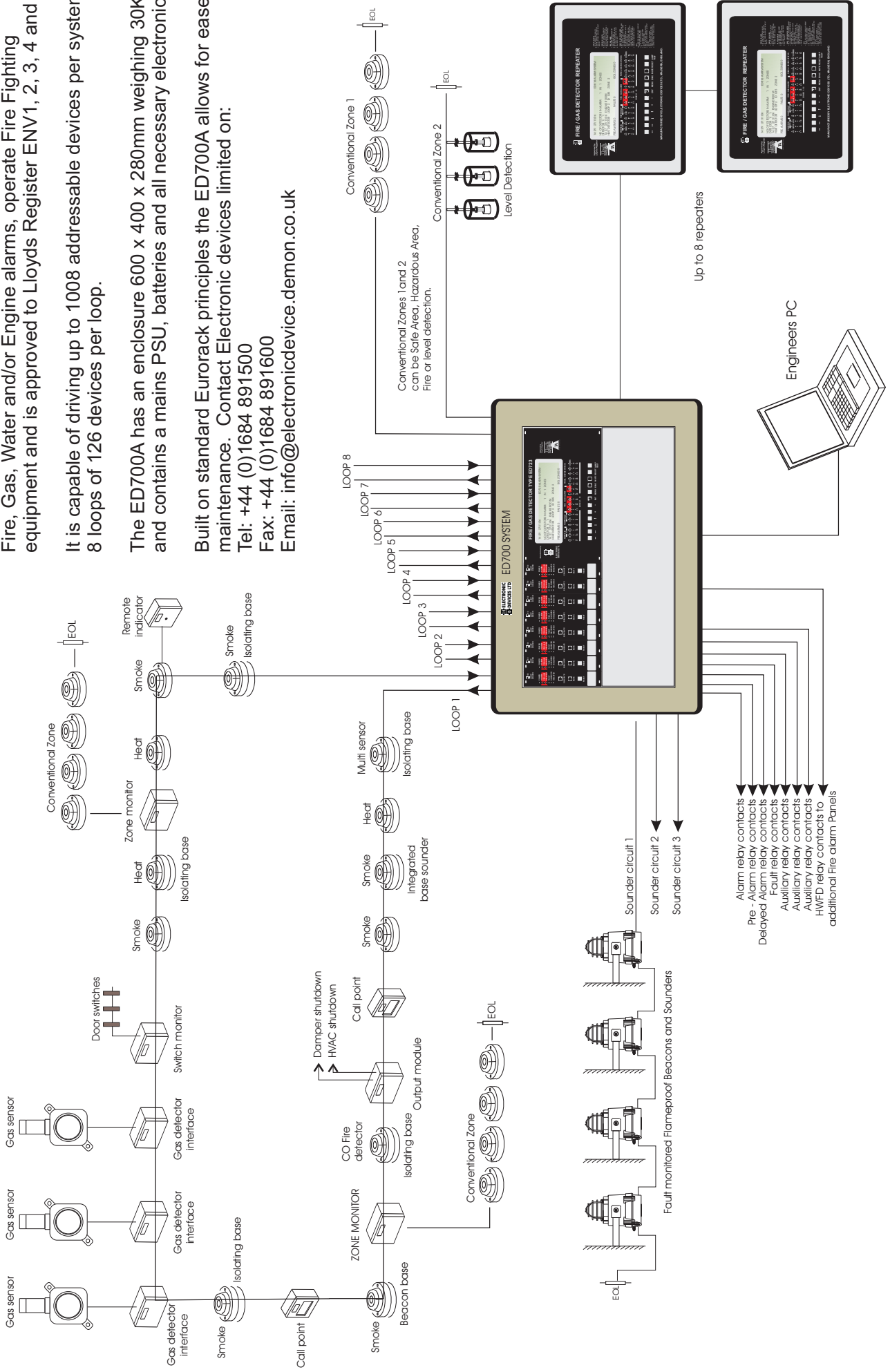

Section 1 - Component overview.
ED722 and ED726 Loop Driver Module

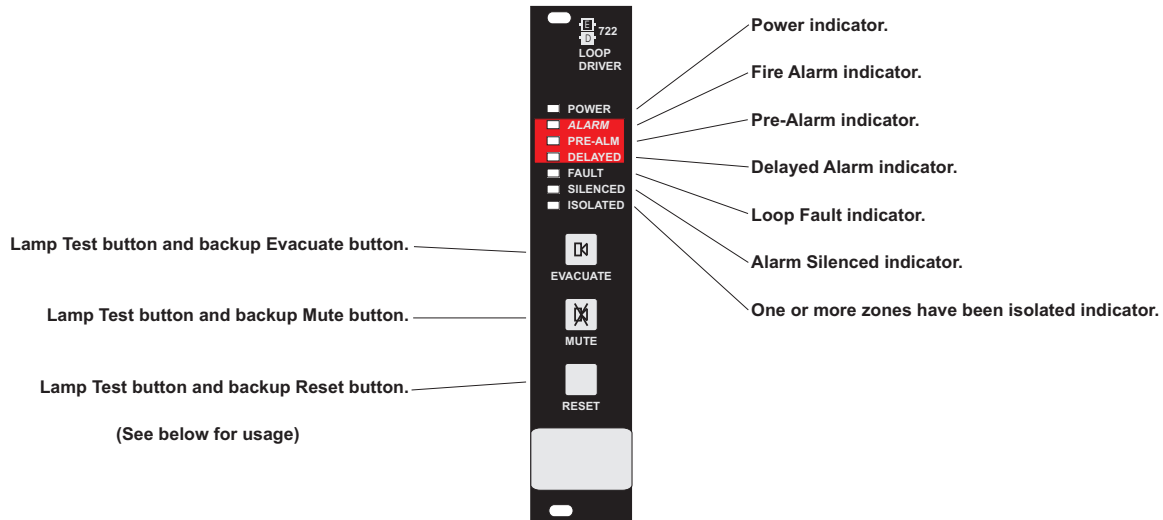

The ED722 and ED726 loop driver can provide 300mA of continuous loop current, driving up to 126 devices using Apollo S90, XP95 or Discovery protocol.

Each loop is fully isolated electrically from the input power supply, giving continued operation in the event of earth faults on the dc input, greatly increasing immunity to electrical noise and eliminating false alarms due to crosstalk.

The ED722 and ED726 are similar but the ED726 can also accept up to 10 EDL addressable gas detection interface modules.

FAIL SAFE OPERATION

Each module within the system (ED722/6 loop modules, ED723 Addressable Display module and ED725 IO module) communicate with each other using an industry standard I2C bus. In the event of a communications failure, or a fault developing on any of the modules, creating a communications failure, the loop cards continue to operate autonomously.

The loop modules are directly connected to the following normally energised relays mounted on the IO module. *These should be used for all safety critical operations as they are operated in the fail safe mode.*

HWFD = normally open contact closing to 470 ohms in the alarm condition.

PRE = Pre-alarm.

IMM = Immediate Fire or Gas Alarm.

DEL = Operates 2 minutes after an alarm if mute or reset has not been pressed.

FLT = Fault.

Sounder 1 is directly connected to the alarm relay.

DISCOVERY CONVENTIONAL MODE (Hardware Fire Detection HWFD)

Not to be confused with conventional fire zones, conventional mode, built into the Discovery detectors and Electronic Devices gas detector interface, provides continued alarm detection in the event of limited circuit failure. E.g. Microprocessor failure on the loop module resulting in panel to detector communications failure. Conventional mode becomes operational approximately 2 minutes after loop to detector communications has failed. Electronic Devices recommend using Discovery detectors to take advantage of this feature.

PUSH BUTTON OPERATION

If pressed under normal operating conditions the three push buttons operate as lamp test buttons only. However in the event of a communications error or fault on the Addressable display module, the loop cards continue to operate autonomously and the push buttons will function as labelled. See page 29 for details.

ED723 Display Module

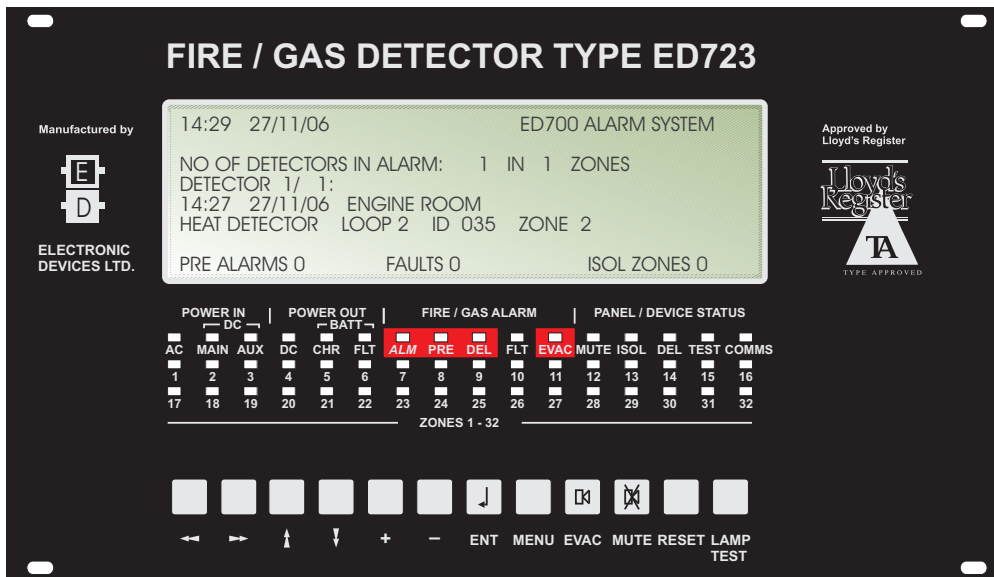

The ED723 Display module provides all system information during normal operation. Detailed information about each device connected to the system, system voltages, Isolated zones, delay times and function are all available.

The ED723 is also available as a standalone Repeater unit, with identical functionality, connected to the main panel via RS485 full duplex. Up to 8 repeaters can be connected to the main system.

LED FUNCTION (left to right)

AC	AC mains connected.
MAIN	Main DC input connected.
AUX	Aux DC input connected.
DC	Fused DC output okay.
CHR	Battery being charged.
FLT	Battery fault.
FIRE	Main Fire or Gas Alarm.
PRE	Pre alarm early warning of Fire or Gas Alarm.
DEL	Delayed Alarm, Fire or Gas Alarm has been present for 2 minutes without being acknowledged.
FLT	Fault on System, wiring or loop device.
EVAC	Evacuate condition has been implemented.
MUTE	Sounders / Beacons have been silenced.
ISOL	1 or more zones have been isolated.
DEL	Delayed output, one of the 8 delayed outputs will action after preset time.
TEST	System is currently in test mode.
COMMS	Communications failure has occurred.
1 - 32	Zone LEDs, indicating a Fire / Gas alarm.

PUSH BUTTON FUNCTION(left to right)

↑↓	Use to scroll through current events and navigate menu.
⇌	Use to navigate menu.
+/-	Increment / decrement.
ENT	Enter confirm.
MENU	Previous menu / main menu.
EVAC	Evacuate, operates all output devices.
MUTE	Turn off Sounders and Beacons.
RESET	Reset to normal condition following alarm or fault.
LAMP TEST	Test all Display Module lamps.

ED725 Input / Output Module

The ED725 Input / Output module provides all of the facilities required for most applications, eliminating the need to purchase additional add-on modules or interface units.

Designed with ease of installation in mind the ED725 is fitted with large terminals capable of easily accepting 4mm square conductors.

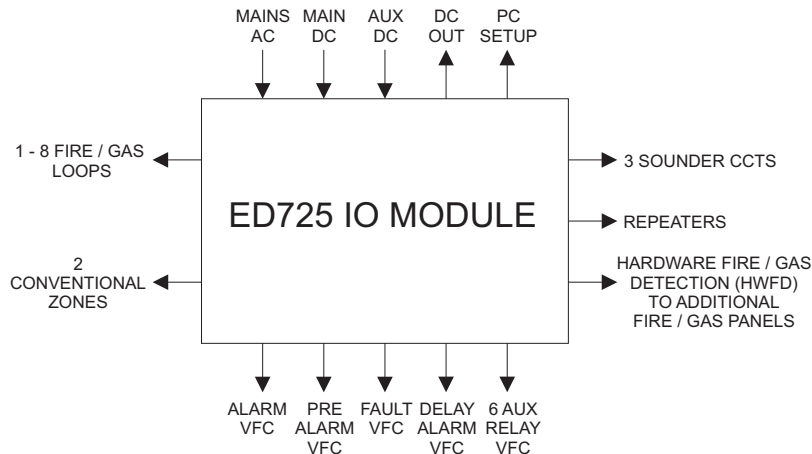

The ED725 provides the following:

Loop input / output terminals for up to 8 loops.

2 x Conventional Fire Detection Zones, ideal for utilising existing conventional detectors when retro fitting. Suitable detectors are Apollo S60 / S65, Apollo Orbis, Tyco M600 and the Hochiki CDX range.

1 x RS232 Comms port for connection to a PC or a laptop running Electronic Devices FireConfig.exe Windows software Application. Use a straight through (not null modem) serial cable with a 9 pin D type male connector on one end and female on the other. If using a laptop which does not have a suitable serial port you will also need a USB to Serial port converter.

1 x RS485 Full Duplex Comms port for connection to up to 8 Repeater modules.

1 x HWFD Relay Output, (Hardware Fire Detection). Normally energised relay output for connection to additional control panels or third party conventional / addressable fire panel. The HWFD contacts are normally open and close to 470 Ohms in the event of an alarm condition. Importantly this relay will continue to operate correctly in the event of internal panel communications failure and also loop communications failure (discovery detectors and EDL gas detectors only).

All relays are Voltage free change over contacts. All are rated at 2.5A @ 30V d.c. non inductive.

1 x Fire Alarm Relay, fail safe hardware driven.

1 x Delayed Fire Alarm Relay.

1 x Pre Alarm Relay.

1 x Fault Alarm Relay contacts.

6 x Auxiliary Alarm Relay contacts, 3 Relays each with 2 sets of Contacts. Configurable using PC application.

3 x Monitored Sounder Circuits rated 1A ; 24V dc. Sounder circuit 1 is fail safe hardware driven. Sounder circuits 2 and 3 are software driven and configurable.

2 x 24VDC Monitored Fused Outputs.

1 x Auxiliary DC Monitored Input, 24V dc +/- 25%..

1 x Battery Input with automatic charging and disconnection before battery damage can occur.

1 x Main DC Monitored Input, normally used with the internal Power Supply, 24V dc +/- 25%..

1 x Main AC Monitored Input.

1 x Internal Buzzer (comms failure).

Section 2 - System design guidelines

LOOP LENGTHS

The maximum permitted loop length can be determined using Apollo's loop calculator, available free from EDL. Remember to include the vertical distances when looking at plan drawings and also ensure cable capacitance is within the panels specification.

LOOP LOADING - Maximum number of addresses

The maximum number of addresses is 126 per loop. System designers should avoid fully loading loops. The optimum number of addresses per loop is approximately 90 to 100, this ensures the system is operating well within its capacity and allows the customer flexibility in the future to add additional devices.

LOOP LOADING - Short circuit isolators

Short circuit isolators should be fitted with no more than 20 detectors between isolators. No more than 10 detectors (or equivalent load) between the panel and the first isolator and no more than 10 detectors (or equivalent load) between the panel and last isolator. Ideally the first and last items fitted to a loop should be isolators.

Isolators should always be fitted at zone boundaries and it is good practice to reduce the number of times loop wiring enters and leaves the same zone. A single fault on a loop should not remove protection from an area greater than a single zone.

Two simultaneous faults on a loop should not remove protection from an area greater than 10,000 sq m . This requirement limits the total floor area covered by one loop to 10,000 sq m regardless of the number of detectors.

Isolators are available as standalone or built in to detector bases and integrated in to Apollo interface modules . The additional cost of the built in isolators is small compared to the non isolated bases or interface units therefore as many isolators should be fitted as possible.

Short circuit isolators do not use up addresses and there is no limit to the number of isolators fitted.

Each loop card is fitted with two onboard short circuit isolators, one for loop out and one for loop return, protecting the wiring between the panel and first and last isolator.

LOOP CABLE SELECTION

The cable must be a suitable type, designed for Fire Detection and must be 2 core with screen + drain core. For marine installations ensure the cable is multi-strand and not solid conductor. Suitable cables include FP200 and FireTuff (multi-strand types).

It is not advisable to have "loop out" and "loop in" conductors within the same cable or to use multicore cable. Damage to this cable may result in more than one fire zone being affected and therefore would not meet the EN54 standard.

LOOP CABLE RESISTANCE

Loop cable resistance is measured between "loop out" and "loop in" terminals. In general larger core diameters allows longer cable lengths provided the maximum permissible capacitance is not exceeded.

Core diameter	Typical resistance (FP200 / FireTuf)
1.0mm	18.1 Ohms/Km/Core
1.5mm	12.1 Ohms/Km/Core
2.5mm	7.4 Ohms/Km/Core
4.0mm	4.6 Ohms/Km/Core

System design guidelines - continued

LOOP CABLE CAPACITANCE

Cable capacitance is an important consideration when choosing loop cable.

The maximum permissible capacitance is 0.5 μ F (500nF) between loop + and loop -.

As each loop is electrically isolated therefore high loop to screen capacitance does not normally cause a problem and should not be the limiting factor for loop lengths.

Typical capacitance per 100m (FP200 / FireTuf)

Core diameter	core to core	core to screen
1.0mm	10nF	17.5nF
1.5mm	12nF	20.5nF
2.5mm	13nF	24.0nF

SCREEN CONTINUITY

It is vital, for correct and trouble free operation, that the screen is continuous along the full loop length. Ensure that the screen connection is continued at each loop device. The screen should be earthed at one end only, via the control panel, and never at loop devices.

All cables entering the control unit should be screened and ferrite sleeves, supplied with the control unit, must be used. All screens should be terminated at the control panel only, thereby avoiding earth loops.

See page 9 for connection diagram.

Note the repeater data cable screens must NOT be connected to the enclosure (earth) and instead connected to the terminals marked SCRIN inside the control unit and repeater units.

REPEATER CABLE SELECTION

The repeater communicates with the control panel using the industry standard RS485 full duplex.

The data cable used should be 2 conductor (twisted) 124 Ohm twinixial 25 AWG (0.16 sq mm) with foil screen and drain wire. E.g. Beldon 9271 006 (BLULT).

Repeaters can be powered locally to avoid running additional power cables or they can be powered from the control unit using the fused output terminals. Up to 8 repeaters can be connected to each system, however if powered from the control panel the repeater current consumption should be included in power supply and battery calculations.

Each repeater can operate from 18 - 30Vdc with a worst case current consumption of 350mA.

See page 10 for connection diagram.

POWER SUPPLY

The control unit requires a nominal 24V dc supply and must always have batteries connected. Normally the AC mains is connected to the AC mains input terminals and the AC mains output terminals are wired to the systems power supply module. The input power supplies DC output is connected to the systems main DC input terminals.

Auxiliary DC input terminals are provided as an additional option. The DC input and Auxiliary (if used) must be suitably rated to charge the internal batteries.

All power supply cables must be screened and ferrite rings used and cables should not be routed near EMC generating equipment, radio transmitters, paging systems etc., See page 9.

Section 3 - Control unit installation

GENERAL

WARNING: Please read this section completely before commencing installation.

The panel must be located in a clean, dry position at least 2 metres away from any other radio transmitting equipment e.g. Pager systems.

The Mains supply should be installed in accordance with the current edition of the IEE wiring regulations. Connection to the mains supply must be via an isolating protective device (e.g. an isolating fuse) reserved solely for the fire alarm system. It should be insured that all isolating switches, circuit breakers etc., connected to the system should be labelled "FIRE ALARM DO NOT SWITCH OFF".

Correct earthing is vital for trouble free operation. The earth connection should be as short as possible, using 4mm square conductors, connected directly to a good quality earth. The earth should not be routed via radio transmitting devices or other electrical equipment.

All cables entering the control unit should be screened and ferrite sleeves, supplied with the control unit, should be used. All screens should be terminated at the cable gland. Only metal, EMC shielding cable glands should be used. Screens should be continuous and have continuity along the entire length of the cable. Only connect the screen to earth at one end thus avoiding earth loops. All unscreened conductors should be kept as short as possible and the ferrite ring should be as close to the cable gland as possible. Wrap each conductor around the ferrite at least twice. Any communication faults experienced are likely to be caused by poor EMC shielding practices. Repeater cable screens should never be connected to earth, always use the terminals provided.

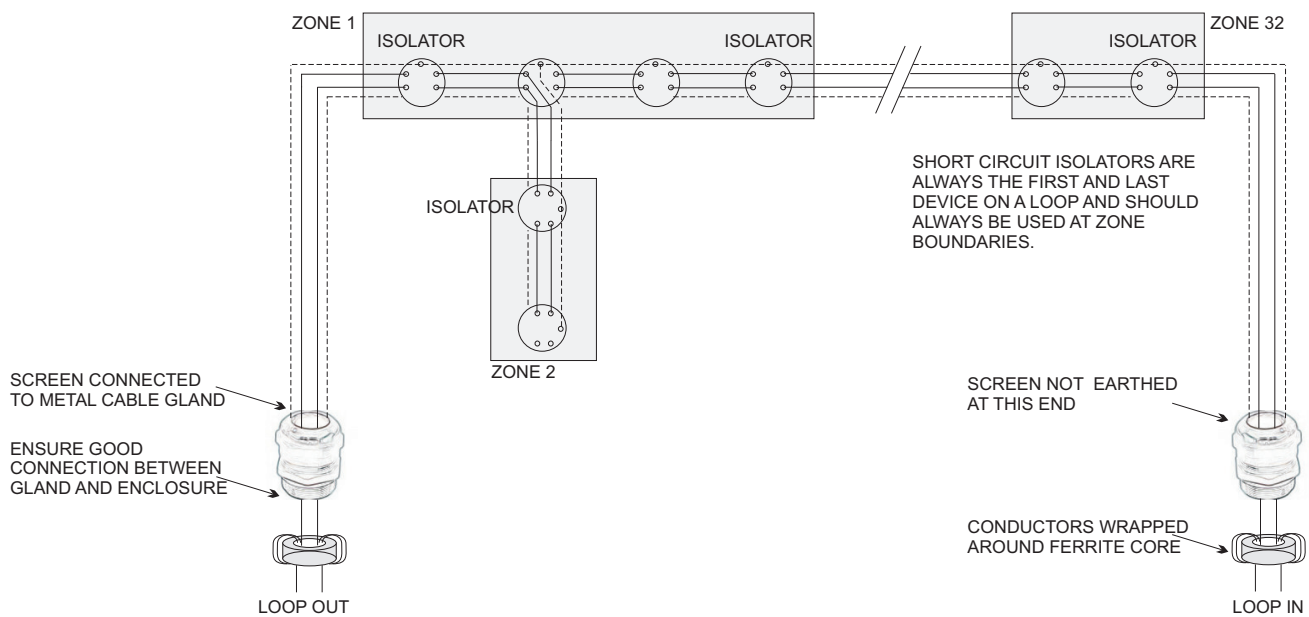

NOTE

When changing any plug-in cards or loop devices, observe anti-static precautions. Ensure that all power is removed and the system is switched off. Failure to do so may result in damage to the cards or panel. The panel **MUST** be switched off before removing or replacing any card or module. Failure to observe this may cause damage to the printed circuit boards.

Each loop card has an ID, set via the dip switches mounted on each loop card. No two loop card should have the same ID.

FireConfig.exe must be used for initial system setup.

ED700A I/O BOARD CONNECTIONS

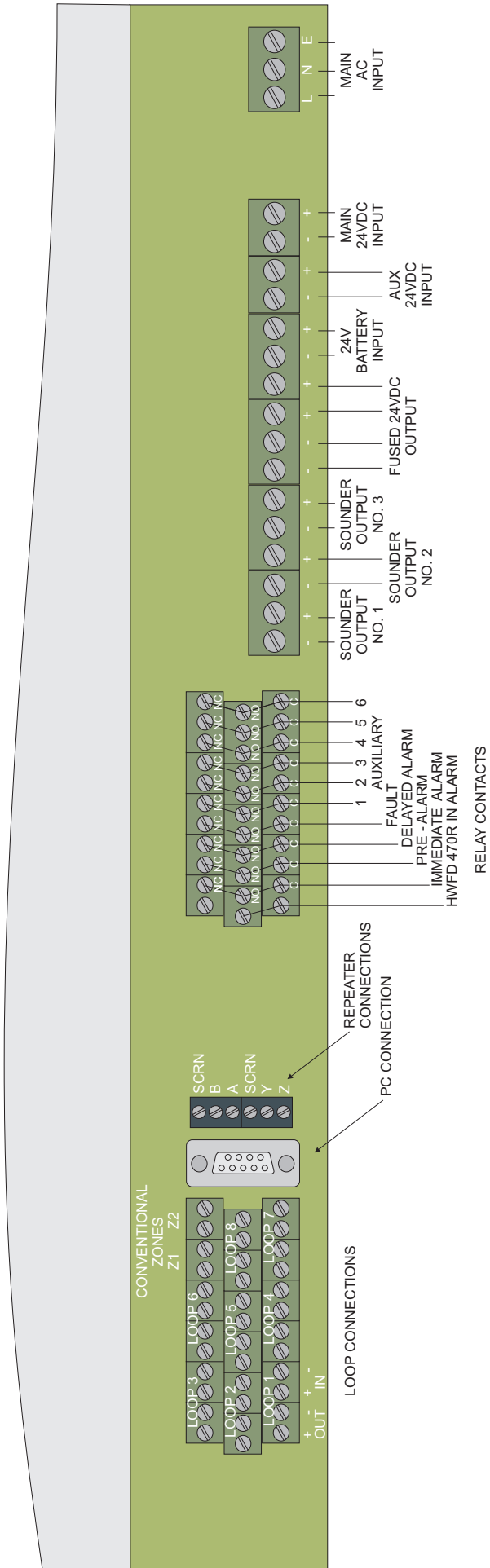

XP95 / DISCOVERY MOUNTING BASE WIRING DIAGRAM

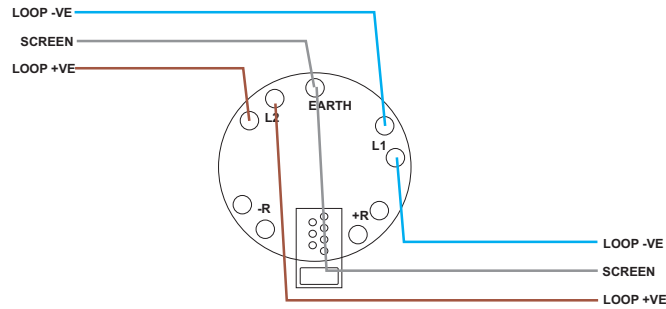

XP95 / DISCOVERY ISOLATING BASE WIRING DIAGRAM

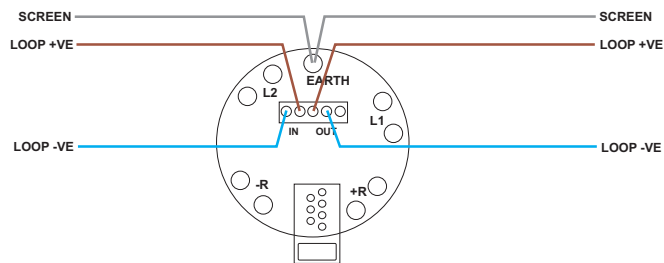

CONVENTIONAL ZONES WIRING DIAGRAM

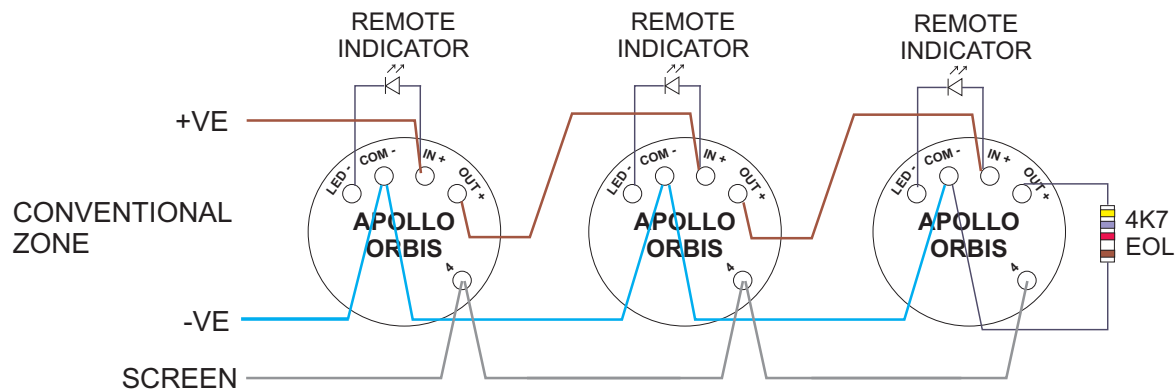

1. Connect detector earth connection to cable screen
2. Always fit call points at the beginning of a zone or on a separate zone. Removal of detectors fitted between the control unit and call points would disable the call points.
3. Never use looped wire for connection into and out from the same terminal, always break wire.
Any single wire coming loose from a terminal should open circuit the end of line resistor to enable a fault to be indicated.

SOUNDER WIRING

The fault monitored sounder circuits can be used to operate several sounders and beacons up to a maximum load of 1A. A 4K7 Ohm end of line resistor should be fitted across the last device to facilitate fault monitoring. Note: SDR1 is fail safe and should always be used first, with sounders / beacons in a manned location.

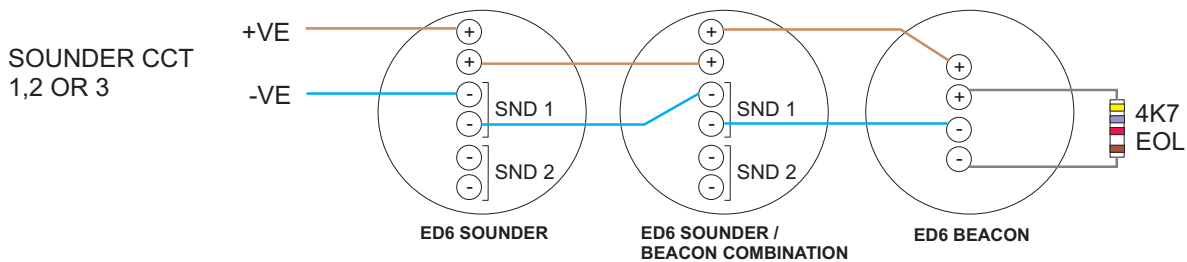

Never use looped wire always use separate conductors for input and outputs thus enabling fault monitoring. If Sounders and Beacons are not supplied by EDL, ensure they have a series polarity protection diode fitted. Please contact EDL for further information.

REPEATER WIRING

Up to eight repeaters can be connected to each system. The last repeater on the line must be a type A. Type A and B repeaters differ only in that type A repeaters have terminating resistors, R2 and R39, fitted.

Repeaters can be powered by a local, battery backed, 24Vdc supply or driven off the fused output terminals provided in the ED700A. Each repeater draws a maximum of 350mA.

The data cable used should be 2 conductor (twisted) 124 Ohm twinixial 25 AWG (0.16 sq mm) with foil screen and drain wire. E.g. Beldon 9271 006 (BLULT).

With full duplex wiring each repeater has exactly the same functionality as the main control panel, giving the designer the option of using the repeater as the main interface. This allows the control panel to be situated in a more central location.

It is possible to operate repeaters without their full functionality by omitting the repeater transmit wiring; i.e. Wiring between Z, Y (repeater) and A, B (control panel). Thus the repeater can only receive information, no information can be transmitted to the control panel including setup information etc.. Electronic Devices Limited do not recommend this method because the EVAC button on the repeater will not function. However a solution is to have a call point located next to the repeater set to "no zone". Call points set to no zone automatically operate the evacuate command when operated. *It is for this reason all repeaters installed should be checked they both transmit data as well as receive it from the control panel.*

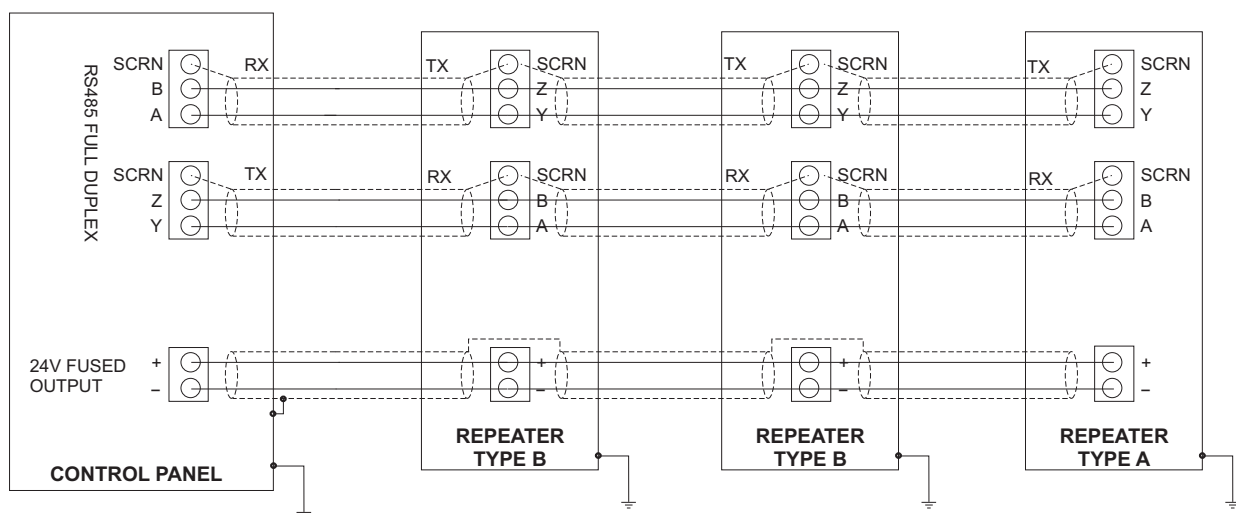

Section 4 - Initial system setup

FIRECONFIG

Fireconfig.exe is a windows based application / program which **MUST** be used for initial system setup.

Install FireConfig.exe on to your Windows XP / Vista PC hard drive or run directly from a data stick if required.

Use a straight through (not null modem) serial cable with a 9 pin D type male connector on one end and female on the other. If using a laptop which does not have a suitable serial port you will also need a USB to Serial port converter.

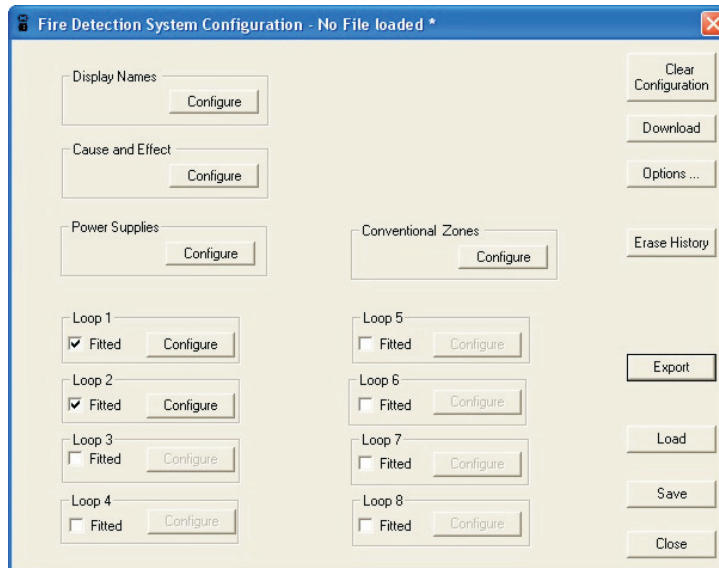

1. Check the loop fitted boxes for all loops fitted. (For the ED816A only loop 1 and 2 are applicable.)
2. Click "Configure" for loop 1.
3. Click "Add Head" and then fill in the details for the first addressable device on the loop.

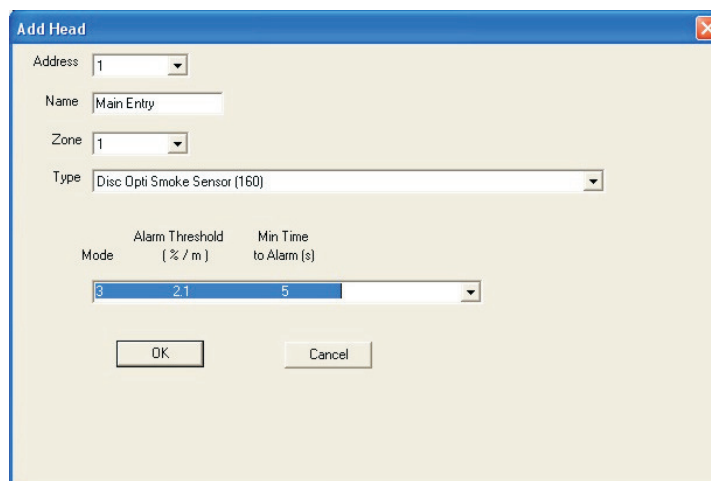

4. Choose the address, which can be 1 to 126.
5. Choose the name, which can be a maximum of 12 characters.
6. Choose the zone, which can be 1 to 32. Additionally No Zone can be specified. Any device going in to alarm, which has not had a zone assigned, will operate the evacuate command and all sounders and beacons will operate. Additionally no delays or zone isolates are allowed.

Initial setup - continued

When choosing some devices additional check boxes / drop down menus may appear, eg. Discovery sensitivity. See DEVICE TYPES AND CONFIGURATION (page 14) for further details.

7. Repeat steps 2 - 6 until all loops are configured.
9. Click "**Display Names**" and choose the text that appears in the top right hand side of the display for both main panel and repeaters.
10. Click "**Power Supplies**" and check the appropriate boxes. If not checked the system will not give fault warnings for that particular supply.
11. Click "**Conventional Zones**", if used, and choose whether the zone is to be used for Hazardous or safe Areas. If "Intrinsically Safe Devices" are chosen the zone wiring must be connected through an Electronic Devices zener barrier type ZBD7+ located in the Safe Area. See connection diagram and also ensure ATEX regulations are met fully.
12. Click "**Save**" to save the configuration to you computers hard drive or data stick.
13. Click "**Export**" to save the configuration to .csv format which can be read and printed using most spread sheet programs e.g. Microsoft excel or openoffice (freeware available from www.openoffice.org).
14. Click "**Options**" to select which comms port your serial cable is attached to. Click test to check both the port and system are working correctly.
15. Click "**Clear configuration**" if the system has previously been configured and now requires changing. This will take several minutes and will *CLEAR ALL* information held in memory.
16. Click "**Erase History**" to clear the history stored in the systems memory.
17. Click "**Download**" to send the data in to the system. This can take several minutes. Once complete turn the system off for one or two seconds before turning back on. Monitor the system closely for the next several minutes, checking for any faults to be reported. Most faults will be reported within 2 minutes, however internal memory and program errors can take up to 1 hour to be reported.

If downloading is interrupted (power failure, pc failure etc.) turn off the systems power and then after a few seconds, re-power the system and, when ready, start the download again.

Section 5 - Cause and Effect Matrix

The Cause and Effect matrix does not have to be used for simple applications. However for the needs of larger and more complicated systems a powerful cause and effect matrix is provided.

IMPORTANT NOTE

It is important to note that in the event of panel failure or communications failure the cause and effect matrix will not function. SNDR1 is the dedicated fire/gas alarm which is operated in failsafe mode and also via the HardWare Fire Detection circuit. The HWFD circuit will continue to give alarms from Discovery detectors and EDL gas detectors in the event of communication failure between panel and loop devices, provided the loop voltage is still correct. Therefore SNDR1 should be the first choice and should always be used with at least one sounder located in a manned area. See page 30.

MAXIMUM NUMBER OF ENTRIES

No more than 50 cause and effects should be used. To help reduce the number of cause and effects the following methods should be used:

1. All sounders, beacons, sounder control units etc., that are to operate from the main fire/gas Alarm should have the "always operate in the event of alarm" check box ticked on the loop configuration page. If this is done no cause and effect entries are necessary.
2. All I/O controllers and Switch monitor I/O modules with inputs only being used to operate the main fire/gas Alarm, should have the appropriate "alarm on bit 0,1 or 2" boxes checked on the loop configuration page. If this is done no cause and effect entries are necessary.
3. If large numbers of loop powered sounders / beacons are to operate from any cause other than the main fire/gas alarm (e.g. Pre-alarm), group addressing and / or master - slave sounders / beacons should be used so that only minimal cause and effect entries are required.

Cause and Effect Matrix - continued

Adding Cause and Effects entries

1. Click “Cause and Effect” and then “add Entry”.

2. Choose a name for the entry.

3. Select the “input type”.

“Device” is any detector, input module, zone monitor or switch monitor on any loop.

“Zone” is any of the 32 zones and also either of the 2 built in conventional zones.

“Loop” is any of the loops attached to the system only loop 1 and 2 apply for the ED816A.

4. Select “Cause”. Cause can be pre-alarm, alarm or fault.

If Zone was chosen for input type an extra cause choice becomes available. “Coincidence” detection is available between any 2 zones. In the event of the 2 zones chosen both being in the alarm condition then the effect will be actioned.

If Device was chosen for input type and the device is an I/O module, 2 extra cause choices become available. **I/O unit Latching** and **I/O unit Non-Latching**.

Apollo manufacture 3 main I/O modules with the following inputs:

<u>I/O module</u>	<u>input bits</u>	<u>FireConfig input</u>	<u>use</u>
Mains switching I/O	0	1	status of monitored switch
	1	2	not used
	2	3	not used
Input Output Unit	0	1	status of monitored switch
	1	2	status of opto input
	2	3	not used
3 Channel Input Output Unit	0	1	status of monitored switch 1
	1	2	status of monitored switch 2
	2	3	status of monitored switch 3

Whilst the monitored switch is open no effect will occur, once the switch closes the chosen effect takes place.

When choosing “I/O unit Latching” the effect will remain until RESET has been pressed, any effect can be chosen from the drop down box.

When Choosing “I/O unit Non-Latching” the effect will remain for only as long as the input is set. Only Loop Devices can be chosen in the “Effect” drop down box. When operating a loop output device only one non-latching cause can be assigned to it.

5. Select Output type in the “effect” dialogue box, which can be Aux Relay, Sounder, Loop Device or Delayed Output.

Cause and Effect Matrix - continued

Aux Relay

There are 3 Auxiliary relays located on the ED725 input / output module, each with 2 sets of voltage free contacts. (Note the ED816A has 1 set of voltage free contacts per aux relay.)

Sounders

There are 3 monitored sounders on the ED725 input / output module. SNDR1 is the dedicated fire/gas alarm which is operated in failsafe mode and also via the HardWare Fire Detection circuit. The HWFD circuit will continue to give alarms, from Discovery detectors and EDL gas detectors, in the event of communication failure between panel and loop devices, provided the loop voltage is still correct. Therefore SNDR1 should be the first choice and should always be used with at least one sounder located in a manned area.

Sounders 2 and 3 are configurable via FireConfig.

Loop Device

When choosing loop device in the “effect” dialogue box it is possible to select any addressable device. However care should be taken to only select suitable devices e.g. Sounders, beacons and output modules. The following guidelines should be observed:

Sounders and beacons

When choosing loop powered sounders / beacons as output devices the set tone drop down box appears. Allowing the commissioning engineer to choose which output bits are set and hence the tone to be used.

Refer to the Apollo data sheets for individual sounder / beacon types, below are the most common examples:

100dB loop powered sounder

<u>Output bit</u>	<u>Action</u>
0	continuous tone
1	pulsed tone
0+1	continuous tone

Intelligent base sounder

<u>Output bit</u>	<u>Action</u>
0	alternates 510hz / 610hz
1	intermittent 510hz
0+1	alternates 510hz / 610hz

Ancillary base sounder

<u>Output bit</u>	<u>Action</u>
0	continuous tone
1	not used
0+1	not used

To avoid confusion it is important to ensure all sounders use the same tones (or as similar as possible) to signal the same condition.

The screenshot shows the 'Add Cause and Effect Entry' dialog box. The 'Name' field is 'eng room sndr'. Under 'Input', 'Input Type' is 'Loop' and 'Details' is 'Loop 1'. Under 'Cause', it is 'Alarm'. Under 'Effect', 'Output Type' is 'Loop Device', 'Details' is 'Device 112 on Loop 1', and there is a note 'XP95 Sndr Cct Controller/Unit: Loop Sndr Beacon (4)'. The 'Set Tone' dropdown is open, showing options: 'Please Choose Sounder Option', 'Bit 0', 'Bit 1', and 'Bits 0 and 1'. The 'Cancel' and 'OK' buttons are at the bottom.

Cause and Effect Matrix - continued

Apollo Input Output modules and Output modules

When choosing Input / Output and Output modules as output devices the output bit drop down box appears, allowing the commissioning engineer to choose which output bits are set and hence the Relay to be switched.

Please note output bits are referred to as output 1,2 and 3 in FireConfig but as output bits 0,1 and 2 in Apollo's literature.

Refer to the Apollo data sheets for individual module types, below are the most common examples:

Mains Switching Input Output unit

<u>Output bit</u>	<u>Action</u>	<u>FireConfig Output</u>
0	relay drive	1
1	not used	2
2	not used	3

3 channel Input Output unit

<u>Output bit</u>	<u>Action</u>	<u>FireConfig Output</u>
0	channel 1 relay	1
1	channel 2 relay	2
2	channel 3 relay	3

Delayed Output

When choosing delayed output in the “effect” drop down box it is possible to setup up to 8 delayed effects. The 8 delayed effects can be called as many times as required by different cause and effect entries, remembering 50 entries is the maximum number of cause and effects allowed.

The “configure delayed outputs” button is at the bottom of the main cause and effects page and brings up the dialogue box shown. Delays can be set anywhere between 1 and 600 seconds.

It is important to ensure all fire / gas detection standards are not infringed when adding delays. E.g. EN54-2 stipulates what can and cannot be delayed when outputs are connected to “fire alarm routing equipment”.

It is possible to override delays at any stage during normal operation by choosing item 6 (delayed outputs) from the main system menu. It should also be remembered that, from within the cause and effect matrix, a dedicated and suitably labelled call point could be assigned the same 8 outputs but without delays thereby giving an easy method to override the delays. Additionally pressing the “EVAC” button or any call point not assigned a zone will operate the evacuate command and all loop powered sounders, beacons, sounders circuits and Immediate Alarm, Pre-Alarm and Delayed output relays will operate.

Section 6 - Device types and configuration

The ED722 and ED726 Loop drivers communicate with loop devices using Apollo Fire Detectors Ltd., protocol S90, XP95 and Discovery.

For most devices it is obvious what selection to make when adding to FireConfig. However it may not be immediately obvious for some devices which is why the device type code is shown in brackets. e.g. Discovery optical smoke detectors are type code 160. All Apollo devices have a type code telling the control panel what the device is and how it operates. If you cannot find a particular device in FireConfig contact EDL or Apollo and obtain the device code.

Additional drop down boxes appear when selecting some devices and fall in to four Categories. Input Output units, Sounder / Beacons, Discovery detectors and Gas Detection.

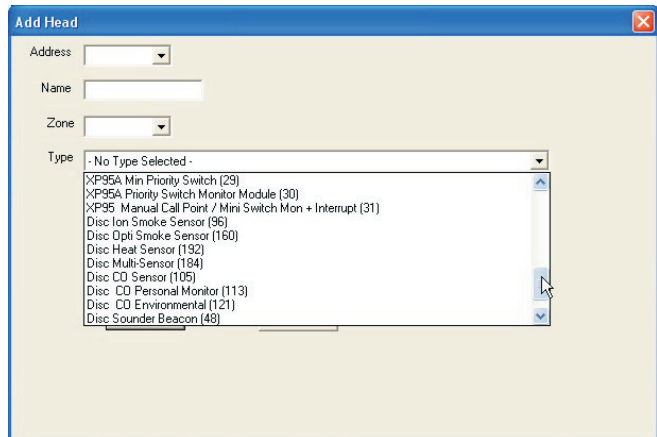

XP95(A) North American Models

XP95(A) the protocol used in North America, is also supported, allowing Apollo devices to be purchased directly from the USA.

Input Output modules / units

When adding Input Output units three check boxes will appear. "Alarm on bit 0,1 or 2". Consult the data sheet and choose which bits, if any, you require to operate the main Fire / Gas alarm. Cause and effect entries are not required if these boxes are ticked.

Check the "never generate alarm" box if the main Fire / Gas alarm is not required and cause and effect entries are to be used instead.

By adding suitable cause and effect entries it is possible for an input module (e.g. Monitoring an Emergency Exit switch) to operate an output module on any loop silently without any front panel indication, buzzers etc., operating.

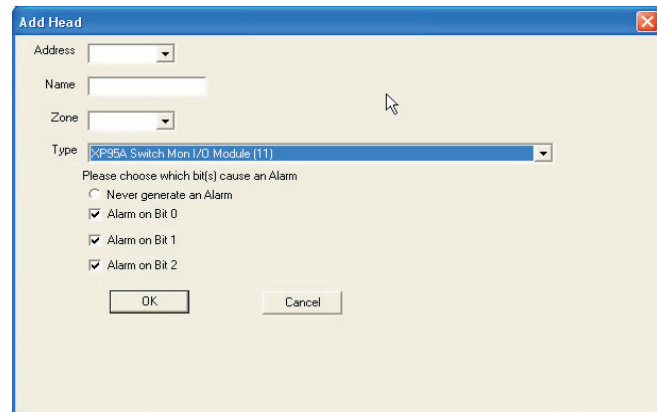

Loop powered Sounder and Beacons

When adding Sounders and Beacons the "Always operate sounder in event of alarm" check box appears. Always check this box for operation from the main Fire / Gas alarm and no cause and effect entries will be required. If left unchecked the device will only operate if a suitable cause and effect entry has been made.

Discovery Detectors

All Discovery detectors have 5 modes of operation to choose from, changing sensitivity, time to respond and for the multi-sensor whether it reacts to heat or smoke only or both.

Device types and configuration - continued

Gas Detection

When adding EDL Gas Detection three dialogue boxes will appear. Sensor range, Pre-Alarm limit and Alarm limit. When choosing the sensor range ensure the sensor is capable of operating correctly within that range. Pre-Alarm and Alarm limits are the value that the gas sensor has to reach before the alarm is given. Both alarm and pre-alarm can be set between 10% and 80% of the sensors range (full scale value) in 10% steps.

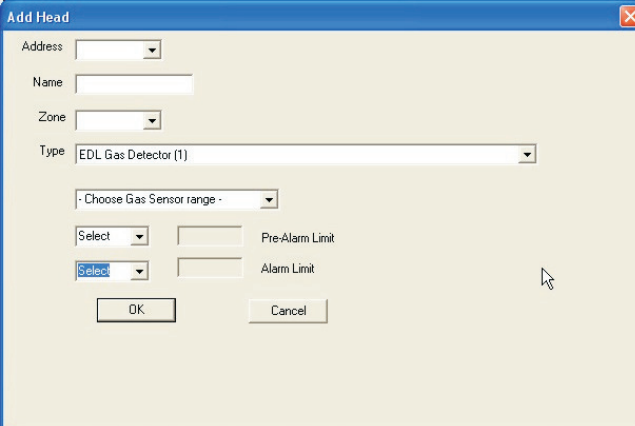

The screenshot shows a software dialog box titled "Add Head" with a close button in the top right corner. The dialog contains the following fields and controls:

- Address:** A dropdown menu.
- Name:** A text input field.
- Zone:** A dropdown menu.
- Type:** A dropdown menu currently showing "EDL Gas Detector (1)".
- Choose Gas Sensor range:** A dropdown menu.
- Pre-Alarm Limit:** A "Select" dropdown menu followed by a text input field.
- Alarm Limit:** A "Select" dropdown menu followed by a text input field.
- Buttons:** "OK" and "Cancel" buttons at the bottom.

Group Addressed Sounders and Beacons

Some Apollo Sounders and Beacons are available with a second set of dip switches used for group addressing., the address must be in the range of 112 - 126. This feature is useful when operating several sounders from a single cause and effect or when adding to an existing system without the need to connect to a PC. Group addressing should be setup as follows:

1. Add a Sounder or Beacon with its individual address in the range 112 - 126 using FireConfig setup software. Ensure this device is NOT group address enabled by setting the group address dip switches to "0000".
2. Add a cause and effect entry to operate the device and / or tick the "always operate in the event of alarm" check box.
3. All additional Sounders / Beacons to be included in this group should be added with their individual addresses in the range 1 - 126 and the group address dip switch should be set to the address chosen in 1 above. Additional sounders / beacons can be added either by using the FireConfig software or using the "search for new devices" function from the main panel or any repeater.
4. Group addressing can only operate on the same loop.
5. Please see Apollo data sheets for more information.

Master / Slave Sounders and Beacons

Some Apollo Sounders and Beacons are available with an additional dip switch for selecting "Master" or "Slave" mode. The feature is has similar benefits to using group addressing but should not be confused with group addressing as the setup is different. Master / Slave sounders should be setup as follows:

1. Add a Sounder or Beacon with its individual address in the range 1 - 126 using FireConfig setup software. Ensure this device is set as "master" using the appropriate dip switch.
2. Add a cause and effect entry to operate the device and / or tick the "always operate in the event of alarm" check box.
3. Additional Sounders or Beacons can be added using the same individual address as above but the units should all be set as "Slave" on the appropriate dip switch.
4. Group addressing can only operate on the same loop.
5. Please see Apollo data sheets for more information.

Section 7 - Operating Instructions - quick guide

Please read the full operating instructions before starting, however below is a quick overview of the most commonly used functions.

Silencing sounders, beacons and internal buzzers (MUTE)

During an alarm or fault condition all sounders, beacons and internal buzzers can be turned off by pressing the “**MUTE**” button. You will be asked to enter a password which is factory set at “AAAAAA”. As this is the default password just pressing enter is sufficient. Once the password has been entered press the “**MUTE**” button once more.

Pressing mute does not stop any customer configured delayed outputs from operating. If the right hand DEL lamp under the panel / device status heading is illuminated one or more (maximum of 8) of the customer configured delayed outputs are due to operate. Pressing the “**RESET**” button will stop the delayed outputs from operating, however if the fire or gas alarm condition returns the count down for the delayed output will start again. If the alarm cannot be rectified before the delayed output operates, once operated it can be turned off by pressing the “**MUTE**” button.

Delayed outputs

If the right hand DEL lamp under the panel / device status heading is illuminated one or more (maximum of 8) of the customer configured delayed outputs are due to operate. Pressing the “**RESET**” button will stop the delayed outputs from operating, however if the fire or gas alarm condition returns the count down for the delayed output will start again. If the alarm cannot be rectified quickly enough the delayed output, once operated, can be turned off by pressing the “**MUTE**” button. One or all of the delay times can be reduced to zero from menu item number 6 in the systems main menu. Use the +/- keys to toggle between “normal” and “no delay”. Use the arrow keys to choose which delay to change or choose global to change all.

System Reset

After an alarm or fault condition has been rectified the system should be reset. Pressing the “**RESET**” button will return the system to the normal state. You will be asked to enter a password which is factory set at “AAAAAA”. As this is the default password just pressing enter is sufficient. Once the password has been entered press the “**RESET**” button once more.

Evacuate

To operate all sounders, beacons, alarm relay and pre-alarm relay press the “**EVAC**” button. You will be asked to enter a password which is factory set at “AAAAAA”. As this is the default password just pressing enter is sufficient. Once the password has been entered press the “**EVAC**” button once more.

Section 8 - Operating instructions

ACCESS LEVELS

The European standard EN54-2 requires access to the control equipment to be split in to 4 levels. The control unit complies through the use of passwords. In order to meet these requirements the control unit door should not be locked.

The ED700A and ED816A systems use the following method of access control:

Access level 1

No password required, allowing access by the general public, or persons having a general responsibility for safety supervision, who might be expected to investigate and initially respond to an alarm or fault warning.

Access level 2

System password is factory set as "AAAAAA", allowing access by persons having a specific responsibility for safety, and who are trained and authorized to operate the control unit in the following conditions:

1. Quiescent condition;
2. Alarm condition;
3. Fault condition;
4. Disabled/isolated condition;
5. Test condition.

Access level 3

System password is factory set as "BBBBBB", allowing access by persons who are trained and authorized to:

1. Re-configure the site specific data held within the control unit and equipment connected to it.
2. Maintain the system.

Access level 4

Connection to PC and the use of Fireconfig software is required, allowing access by persons trained to re-configure the system.

SWITCH ON/REBOOT SCREEN

At switch on or after system reboot the following screen will be displayed:

```
ED720 SYSTEM CHECKING FOR LOOP CARDS:
1. RESPONDING           5.
2. RESPONDING           6.
3.                      7.
4.                      8.
                THIS DISPLAY ID: RACK 0
```

Each loop card fitted should be listed as responding. Each display / repeater has a different ID, set via dip switches. No two repeaters should have the same ID.

Press the menu key and the following screen will be displayed:

```
10:51 05/06/08           ELECTRONIC DEVICES
NO OF DETECTORS IN ALARM: 0 IN 0 ZONES
PRE ALARMS 0 FAULTS 0 ISOL ZONES 0
```

This is the normally displayed screen. The text in the top right can, at commissioning, be changed to suit each application.

Operating instructions - main menu

Pressing the menu key will display the main menu page:

```
10:51 05/06/08      MAIN MENU      USER 1
1. HISTORY           8. REBOOT SYSTEM
2. ISOLATE DEISOLATE 9. LIVE VALUES
3. SETUP            10. CHANGE USER LEVEL
4. SYSTEM MENU      11. VIEW FAULTS
5. GAS DETECTION    12. VIEW PRE ALARMS
6. DELAYED ALARMS  13. VIEW ISOLATES
7. RETURN: MAIN MENU
```

Each menu item is described below:

Use the arrow keys to scroll through to the menu item required and then press the enter key. Pressing the menu key will always return the display to the previous screen until the normally displayed screen is reached.

1. MAIN MENU > HISTORY

The events logged in history will be displayed starting with the *first* event logged. Press the up arrow key to go to the last event logged. Use the up / down arrow keys to scroll through all of the events recorded.

The system has a 999 log memory, once the memory is full new events will continue to be stored whilst the oldest will be lost. History can be cleared using a PC running FireConfig.

2. MAIN MENU > ISOLATE DE-ISOLATE

User access level 2 is required. After entering the password press "ENTER" and the main menu will be displayed but now you are at access level 2, press "ENTER" again for Isolate deisolate.

Use the left right arrow keys to select either *ISOLATE* or *DE-ISOLATE* and press return.

ISOLATE

```
10:51 05/06/08      ISOLATE ZONES
ZONES ISOLATED: 00
ISOLATE ZONE # 01
TIME MINS: 000 (MAX = 240, 000=CONTINUOUS)
OK
```

Using the +/- keys enter the zone number to be isolated. Use the down arrow key to scroll to TIME MINS. Using the +/- keys enter up to 240 minutes (4 hours), or leave at 000 (continuously isolated). Use the down arrow key to scroll to ok and press return. The ISOL led should now illuminate and on the main page the number of zones isolated should be indicated in the bottom right of the display.

DEISOLATE

```
10:51 05/06/08      DEISOLATE ZONES
ZONES ISOLATED: 01
DEISOLATE ZONE # 01
OK
```

Using the +/- keys enter the zone number to be isolated. Use the down arrow key to scroll to "OK" and press return.

Operating instructions - system setup

3. MAIN MENU > SYSTEM SETUP

User access level 3 is required. After entering the password press “ENTER” and the main menu will be displayed, press “ENTER” again for setup. The following screen will be displayed:

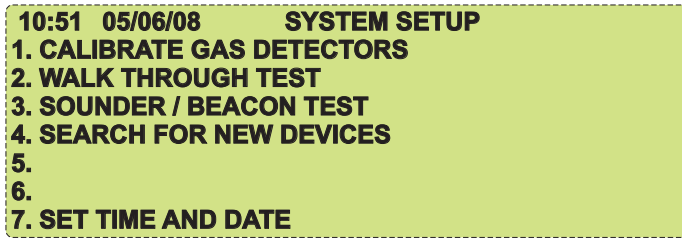

MAIN MENU > SYSTEM SETUP > CALIBRATE GAS DETECTORS

See item 5, page 24.

MAIN MENU > SYSTEM SETUP > WALK THROUGH TEST

The walk through test feature allows the commissioning Engineer to test each detector in turn either by loop or zone without the alarms or any cause and effects operating. At the end of the test the user can scroll through a list of all devices that responded and in the order they were tested. The walk through isolates all outputs of the chosen zone or loop. The test must be ended by pressing menu or enter when prompted. If the test is interrupted, due to an alarm, pre-alarm etc., the user **MUST** return to the test menu and end the previously started test at the same display as initially used to start the test. The walk through test is conducted as follows:

- a. Use the arrow keys and scroll down to “WALK THROUGH TEST” and press “ENTER”.
- b. Using the +/- keys choose the loop to be tested or press the right arrow key to choose a zone to be tested. Scroll down to “OK” and press “ENTER”. The “TEST” light should now be illuminated.
- c. Test each detector in turn. Once the device has activated its alarm light will illuminate and you can move on to the next device.
- d. Once you have tested all devices ensure all devices are no longer in alarm / pre-alarm before pressing enter. The control panel will indicate how many devices have been tested and display the details one at a time. Scroll through tested devices using the up/down arrow keys. Once finished with the information press menu to return to the previous screen. Before starting another test wait at least 1 minute. If finished press menu again until the main screen is displayed.
- e. Check that the “TEST” lamp on the Display AND the “ISOL” lamp on the Loop cards are not illuminated. Turning the power to the system off and then back on again will ensure no zones or loops are left isolated.

It is important to remember that the walk through test is a tool for the commissioning engineer to ensure all devices are in correct locations and are the correct type. Walk through test does NOT test any output functions and cause and effects, therefore it is vital separate tests are conducted testing every aspect of the cause and effect matrix and output functions. Input / Output modules cannot be tested with the walk through test.

Smoke detectors only require a single, short burst of test smoke with the canister held at least 60cm away or, preferably, use a test smoke dispenser. Over exposure to test smoke will coat the sensor and reduce working life. It will require cleaning by a suitably trained person.

MAIN MENU > SYSTEM SETUP > SOUNDER BEACON TEST

The sounder / beacon test feature allows the commissioning Engineer to test each loop sounder, beacon or sounder control module in turn. Each device can be operated for a set period of time adjustable from 30 to 240S. The sounder / beacon test is conducted as follows:

- a. Use the arrow keys and scroll down to “WALK THROUGH TEST” and press “ENTER”..
- b. Using the +/- keys choose the loop to be tested or press the right arrow key to choose a zone to be tested. Scroll down and adjust the time as required. Scroll down to “OK” and press “ENTER”.
- c. Each sounder and beacon will be tested in order starting at the lowest address.
- d. Move to each device location and ensure correct operation. Once all devices have been tested press menu and start another test or press menu again until the main screen is displayed.

It is important to note that the sounder / beacon test will test every sounder and beacon on the loop / zone regardless of whether the system has been configured to operate them. Therefore it is vital separate tests are conducted testing every aspect of the cause and effect matrix ensuring all devices operate and with correct tones etc..

Operating instructions - system setup continued

MAIN MENU > SYSTEM SETUP > SEARCH FOR NEW DEVICES

The search for new devices feature allows additional addressable devices to be added to the system without the use of a PC and the FireConfig software. The search will find all new devices fitted to a loop, however, it **should not** be used for gas detection or Sounders and / or Beacons except when adding to an existing group of group addressed Sounder / Beacons, see section x on group addressing.

The search for new devices feature is conducted as follows:

- a. Use the arrow keys and scroll down to search for new devices and press enter. The system will scan all unused addresses starting at the lowest until a new device is found.
- b. Once a new device has been found use the +/- keys and left right arrow keys to enter a name and zone number, scroll down to ADD and press enter, or SKIP if you do not wish to add the new device. The name can be alphanumeric with a maximum of 12 characters, including spaces.
- c. The search will continue until all unused addresses are checked. When finished will display the following text "NO FURTHER DEVICES FOUND". Scroll down to END and press enter.
- d. The scan can be finished at any time by pressing menu.

MAIN MENU > SYSTEM SETUP > SET TIME AND DATE

Manually enter the time and date, this will automatically update all other displays connected to the system..

4. MAIN MENU > SYSTEM MENU

Displays software version

5. MAIN MENU > GAS DETECTION

The gas detection feature allows the user to scroll through all of the gas detector sensors connected viewing the current gas concentration. Additionally the calibration mode (CAL MODE) can be turned on allowing calibration of the gas sensors without any cause and effects or outputs operating. The fire detection remains fully operational during CAL MODE. If the calibration is interrupted, due to an alarm, pre-alarm etc., the user **MUST** return to the Gas Detection menu and turn off the calibration mode.

```
10:51 05/06/08      GAS DETECTION      USER 1
LOOP: 1  SENSOR: 1  CAL MODE: OFF
HYC #1 E. RM
CONCENTRATION: 0% LEL
CHANGE CAL MODE: OFF
```

View the gas sensors concentration as follows:

- a. Use the arrow keys and scroll to gas detection and press enter.
- b. Using the +/- keys select a loop with gas sensors connected. The first of up to 10 sensors permitted per loop will be displayed.
- c. Press the right arrow key to move over to the sensor number. Use the +/- keys to change sensor number.
- d. Repeat c., above, to view all gas sensors fitted, up to 10 per loop.

Calibrate the gas sensors as follow:

- e. Use the down arrow key and go down to change cal mode. Use the +/- keys to turn the cal mode on or off. Enter user level 2 password and press enter twice. When in calibration mode the *ISOL* light will be illuminated indicating all gas sensors are isolated.
- f. Once calibration is complete turn cal mode off as stated above. Check that the *ISOL* lamp on the Display AND the *ISOL* lamp on the Loop cards are not illuminated. Turning the system off and then back on again will ensure no gas sensors are left isolated.

Operating instructions - delayed alarms

6. MAIN MENU > DELAYED ALARMS

The system has 8 delayed outputs, each delay can be between 1 and 600 seconds. Each delay can be called as many times as required (up to a cause and effect limit of 50). The output each delay operates, the delay time and what starts the delay are all configured using FireConfig during system setup. However each delay time can be individually reduced to zero, or all 8 (global) can be reduced to zero at the same time from the Delayed alarms menu.

```
10:51 05/06/08      DELAYED ALARM      USER 1
SHOWING DELAYED ALARM      1
SOUNDER 2                      DELAY TIME 120S
GLOBAL DELAY - NORMAL      DELAY 1 - NORMAL
```

- a. Use the arrow keys and scroll down to delayed alarms and press enter. The delayed alarm1 will be displayed showing which output device will be operated (sounder, loop device, aux relay) and the delay time is also displayed.
- b. Use the up / down arrow keys to scroll through all 8 delays.
- c. Pressing the - key will reduce the global delay (all 8 at the same time) to zero i.e. “no delay”. Press enter to store this change or press the + key to return global delays to “normal”.
- d. Pressing the right arrow key will scroll across to the individual delay, each delay can be reduced to zero using the +/- keys.

7. MAIN MENU > RETURN TO MAIN PAGE

Has the same function as pressing menu and returns to the main page.

8. MAIN MENU > REBOOT SYSTEM

The Reboot option is a more fundamental function and allows the user to attempt to re-establish communications between the internal modules in the event of a communications error. During normal operation this function should not be required. Additionally rebooting the system will clear all isolated zones and reset the global delay to “normal”. Individual delays will remain unaffected.

- a. Use the arrow keys and scroll across to reboot system and press enter.
- b. Enter the level 2 password and press enter twice. Press the left arrow key and then “ENTER”. The system will reboot and display all responding loop cards.

9. MAIN MENU > LIVE VALUES

The “LIVE VALUES” menu is a very useful commissioning and fault finding tool displaying system voltages, conventional zone voltages, and loop devices details.

- a. Use the arrow keys and scroll across to Live values and press enter.
- B. Two options are available 1. System voltages, 2. Head values.

MAIN MENU > LIVE VALUES > SYSTEM VOLTAGES

```
10:51 05/06/08      LIVE VOLTAGES      USER 1
MAIN SUPPLY: 27.5V      SOUNDER 1: 1.4V
AUX SUPPLY: 0V          SOUNDER 2: 1.4V
BATT SUPPLY: 26.9V      SOUNDER 3: 1.4V
CONV ZONE 1: 18.1V      CONV ZONE 2: 18.3V
```

Operating instructions - system voltages continued

MAIN SUPPLY and AUX SUPPLY

The main DC supply and Auxiliary DC (if used) are nominally 24V+/- 25% in normal use. The battery will charge from either the main DC or Aux DC which ever is higher.

CONV ZONE 1 and CONV ZONE 2

Both conventional zones are powered via a regulated 20VDC supply and should be approximately 18V in normal condition. If the end of line resistor is removed this voltage will rise and the open circuit fault warning will be given. A short circuit across the zone will see the voltage fall to almost 0V and the short circuit fault warning given. In the alarm condition the conventional zone voltage will fall to approximately 10V and the alarm warning given. There is a delay of approximately 6 seconds before a fault or alarm condition is signalled.

SOUNDER 1, 2 and 3.

The voltage displayed is the circuit monitoring voltage which is connected with reverse polarity and should be approximately 1.5V in the normal condition, rising to approximately 2.3 V for open circuit and dropping to nearly 0V for a short circuit.

MAIN MENU > LIVE VALUES > HEAD VALUES.

10:51 05/06/08	HEAD VALUES		USER 1
LOOP NUMBER:	1	HEAD NUMBER:	20
ANALOGUE VALUE:	16	CONFIGURED:	YES
PRE ALARM:	NO	OUTPUT BITS:	0
ALARM:	NO	INPUT BITS:	0
FAULT:	NO	PROTOCOL:	XP95
LIVE DEVICE CODE:	4	SNDR CTRL UNIT	XP95
CONFG DEVICE CODE:	4	SNDR CTRL UNIT	XP95

LOOP NUMBER

Indicates the loop number of the device currently being displayed. Use the +/- arrow keys to change loop number.

ANALOGUE VALUE

This is the current analogue value being returned by the device currently being displayed. For a Sounder control unit, as in the example above, this would be normally 16. Less than 10 would indicate a fault. For detectors this value will rise as the detected medium increases (smoke, heat etc.) For standard Apollo detectors the pre-alarm value is 45 and the alarm value is 55.

PRE ALARM, ALARM and FAULT

Indicates whether the device currently being displayed is in the pre alarm, alarm or fault condition.

LIVE DEVICE CODE

Displays the actual Apollo type code, the device type and protocol used by the device currently being displayed.

CONFG DEVICE CODE

Displays the configured Apollo type code, the device type and protocol used by the device currently being displayed. This is the code entered using the FireConfig software. If, during setup, this code was entered incorrectly and is different to the actual code returned by the device the system will go in to fault condition and an "incorrect device code fault" message will be displayed.

HEAD NUMBER

Displays the address of the device currently being displayed. Use the +/- arrow keys to change.

CONFIGURED

Indicates whether the current address is used.

Operating instructions - live values continued

OUTPUT BITS

This is the current output bit value being returned by the device currently being displayed, indicating which output bits are set.

Displayed Value	bit 2	bit 1	bit 0
0	0	0	0
1	0	0	1
2	0	1	0
3	0	1	1
4	1	0	0
5	1	0	1
6	1	1	0
7	1	1	1

INPUT BITS

This is the current input bit value being returned by the device currently being displayed, indicating which input bits are set.

Displayed Value	bit 2	bit 1	bit 0
0	0	0	0
1	0	0	1
2	0	1	0
3	0	1	1
4	1	0	0
5	1	0	1
6	1	1	0
7	1	1	1

PROTOCOL

This is the protocol used by the device currently being displayed.

10. MAIN MENU > CHANGE USER LEVEL

Enter password and change user level, see the beginning of this chapter for more details.

11. MAIN MENU > VIEW FAULTS

Displays all current faults. Use up / down arrows to scroll through all current faults. This page will be automatically displayed in the event of a new fault occurring.

12. MAIN MENU > VIEW PRE ALARMS

Displays all current pre alarms. Use up / down arrows to scroll through all current pre alarms. This page will be automatically displayed in the event of a new pre-alarm occurring.

13. MAIN MENU > VIEW ISOLATES

Displays all current isolated zones, in two rows. Zone 32, top left and zone 1, bottom right. "D" indicates the zone is disabled (isolated) and "-" indicates the normal non-isolated condition.

Section 9 - Fault messages

It is vital any faults be immediately checked and diagnosed by a qualified Engineer with experience of this control panel.

IO to Loop cable fault

The control unit monitors the connection of all internal ribbon cables. The position of the IO to loop ribbon cable depends upon the number of loop cards fitted. If the number of loop cards has changed from the originally manufactured unit the ribbon cable will require moving to the correct location. Contact EDL for further information on correctly locating the ribbon cable. Failure to correctly position the ribbon cable will mean a **dangerous** loss of alarm/fault signals from some loop cards. It is important to note the control unit will only check the location once, at switch on. Once reset the fault will not be reported again until the unit is switched off and on again, even if it still exists. It will be recorded in history.

If after clearing the configuration, using FireConfig, the system is not immediately reconfigured this may be because the system defaults to single loop setup. Therefore it is important the system is configured and the correct number of loop cards entered.

Loop continuity

The "LOOP IN" terminals are constantly monitored by the control panel. If a short circuit or open circuit occurs the panel will display the fault condition. The fault should be investigated as soon as possible because it is likely some devices, or even all, are not able to respond and therefore not operate.

It is quite likely other fault warnings will be coupled with loop continuity e.g. No response from sensor.

No response from sensor.

This fault message will include the loop and device address and can occur for any addressed device on the loop including sounders and beacons. This fault indicates an open or short circuit loop problem, device failure or if the device has been removed.

Sensor internal fault.

This fault message will include the loop and device address and can occur for any addressed device on the loop including sounders and beacons. The device has registered an internal fault and should be returned for servicing.

For Apollo Discovery devices the analogue value should be checked by using the **main menu > live values > head values**, because additional information can be obtained:

Apollo discovery analogue value	fault type
0	Internal device memory problem
1	Primary sensing element failure
2	Secondary sensing element failure
3	n/a
4	General fault
5	n/a
6	Drift compensation limit.
7	communication failure
8	n/a

Apollo discovery optical smoke and multi-sensors use drift compensation to allow for dirty sensing elements. Eventually the device cannot compensate any more and requires cleaning. The unit should be returned to Apollo, EDL, or a distributor for servicing. It is important to realise that when testing with synthetic smoke only small amounts of test smoke are required. It is very easy to coat the sensing element of the detector quickly bringing it to the limit of compensation.

Short circuit fault and open circuit fault

Both conventional zones and all three sounder circuits wiring are monitored for both open and short circuit. The fault should be investigated as soon as possible because it is likely that some, or even all, devices are not able to respond and therefore not operate.

If during an alarm a sounder circuit fault is reported it should be assumed some or all audible and visual alarms are not working and other methods of drawing attention to the dangers should be employed.

Operating instructions - fault messages continued

Supply voltage fault

All of the input power supplies to the control unit and also the dc fused output are monitored.

Battery open circuit - please replace / Battery too low to charge - please remove and charge

The battery is monitored for open circuit and under voltage. If the system has been running off batteries for some time it is likely the battery voltage is very low. If when the AC mains is restored the battery voltage is below approximately 22V the system will not charge the batteries, avoiding high charging currents and excessive heat generated inside the control unit. The batteries should be removed and charged using a dedicated battery charger.

No response from Loop Card or I/O Card - Comms error.

The Display, I/O module and Loop cards all communicate with each other. If one of these modules develops a fault it is possible for this communication to fail. It is also possible for a communications error to occur if the system is subjected to extreme RFI. In the event of a communications failure the Comms lamp will be illuminated and the internal buzzers will operate.

The system automatically tries to recover from a comms error and pressing the reset button may restore communications. If the system is unable to recover removing the power, including the batteries, may solve the problem. If the communication fault was caused by a hardware failure it will not be possible to recover.

*It is **important to note** that in the event of a communication fault system operation may be severely affected. Cause and effects programmed may not operate and the display module may not be able to operate correctly. However if the loop cards are still operational the system will still continue to operate in a limited manner. In the event of a communications fault the push buttons "EVACUATE", "MUTE" and "RESET" located on the ED722 and ED726 become operational (in normal operation they act only as lamp test buttons).*

In the event of an internal communications fault:

1. Press "RESET".
or
2. Turn off the system, wait a few seconds and then turn it back on.
or
3. If the display module, is still operational, reboot the system. See page 25.

If the above does not allow the system to recover its normal operating condition arrange for an **Engineer to visit immediately**. Next check the status of the system to establish what functions, detectors etc., are still operational, as follows:

4. Check the power light is on each module within the system as the fault could be caused by a blown fuse. If a fuse has blown on any of the ED722 or ED726 Loop modules or the fuse feeding the I/O module has blown, the Alarm, Pre-Alarm, Fault and Delayed relays, HWFD output and Sounder 1 will also operate.
5. Test the detectors and other loop devices on each loop and conventional zones, if used, to establish which devices are still operational.
6. In the event of a **Fire** the loop sounders and beacons can be silenced by pressing the "MUTE" button on *each* of the ED722 or ED726 Loop modules . Loop devices can be reset by pressing the "RESET" button on *each* of the ED722 or ED726 Loop modules.
7. To **Evacuate** press the "EVACUATE" button on *each* of the ED722 or ED726 Loop modules.

Section 10 - Dual Redundancy

Discovery Conventional Mode and the Hardware Fire Detection Circuit (HWFD)

All addressable loop devices communicate with the Loop cards, ED722 and ED726, using the Apollo S90, XP95 or Discovery protocol. If this communication fails (due to microprocessor failure etc.) most panels would have a total loss of Alarm detection, a very dangerous situation. The ED700A and ED816A have Dual Redundancy, a secondary method of Fire and Gas Detection, is built in to each ED722 and ED726 module when used with Discovery detectors and EDL's Gas Detector Interface Units. In the event of communications failure, between the detectors and the control panel, the detectors can still respond to a Fire or Gas alarm but cannot give the location details.

For communications to have failed some hardware / software failure most have occurred. It is likely many fault messages will be displayed depending upon what has failed and an **Engineer should be called immediately**. It is impossible to say how much of the system will still function without knowing the exact problem. The minimum being that Sounder 1 circuit and the relays operate. If the ED722 / ED726 Loop card microprocessor is still functioning correctly the following will occur in the event of a Fire or Gas Alarm:

The alarm lamps, buzzers, relays will operate and the following screen will be displayed:

```
10:51 05/06/08          ELECTRONIC DEVICES
NO OF DETECTORS IN ALARM:  1  IN  0 ZONES
10:50 05/06/08 CONV MODE ALARM
FIRE ON LOOP 1

PRE ALARMS    0  FAULTS    0  ISOL ZONES  0
```

Loop powered Sounders, Beacons or Output module attached to the faulty loop WILL NOT operate. If internal system communications are functioning the EVAC command will also be given, operating the Immediate Fire / Gas alarm relay, the pre-alarm relay and Sounders 2 and 3. All sounders connected to fully functional loops will also operate.

Pressing "MUTE" will silence all sounders. Removing the detector in alarm and pressing the "RESET" buttons on both the ED722 / ED726 Loop module and ED700A Display will reset the system. If the detector in alarm cannot be removed ensure it is clear of smoke, heat etc. and then the ED700A should be turned off for a few seconds and then turned on.

If Sounder 1 does not silence and the Immediate alarm, delayed alarm, pre-alarm and the fault relay do not return to the normal state this is indication of either loop card removal, loop card microprocessor failure or I/O module failure.