

DOOR OPERATORS

by Michael A. Von Dohre and Tony Cecere, Atlantic Tech Systems, LLC



Car Simulator

One of the most important functions of the complete elevator system is the smooth and safe operation of the car and hoistway door package. The doors need to be hung square, plumb and level. They need to be free of all mechanical binds, dirt and oil. The rewards of a good quality installation will be fewer callbacks and a reduction in maintenance expenses. This will increase the life of the doors and door operator and provide

many years of trouble-free service for both the customer and the elevator maintenance company.

Most door operators today are similar in operation. They have a power source from the main elevator controller and inputs from the elevator controller to monitor the door-control operation and safety circuits for proper operation. The power sources and controller inputs for all door-operator packages are generally uniform. The main difference in the elevator manufacturer's elevator controller is the controller voltage for the outputs and inputs needed to provide a safe and proper operation of the entire door operation. The voltages can generally vary from 24- to 110 volts in either AC or DC voltage. The power is then converted within the door-operator manufacturer's board. The board will either be relay logic or have a microprocessor that monitors and controls the operation of the doors. The different board applications can serve both the major elevator companies and the independent elevator companies in the industry. This allows the limited use/limited access (LULA), residential, wraparound, commercial and linear-drive hydraulic-operator packages to be customized to customers' needs. These products are built to adapt to new installations, service, repair, maintenance and modernization projects.

Atlantic Tech Systems, LLC utilizes a microprocessor in LULA, residential, wraparound and commercial door-operator control boards. These door-operator packages have three different solid-state boards from which to choose based on customer needs. The linear-drive or hydraulic door-operator packages are relay logic with three different relay-logic boards to choose from.

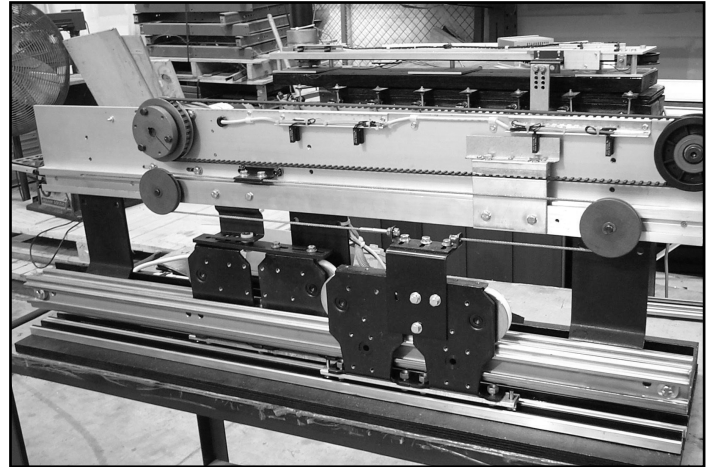

LULA Door Operator

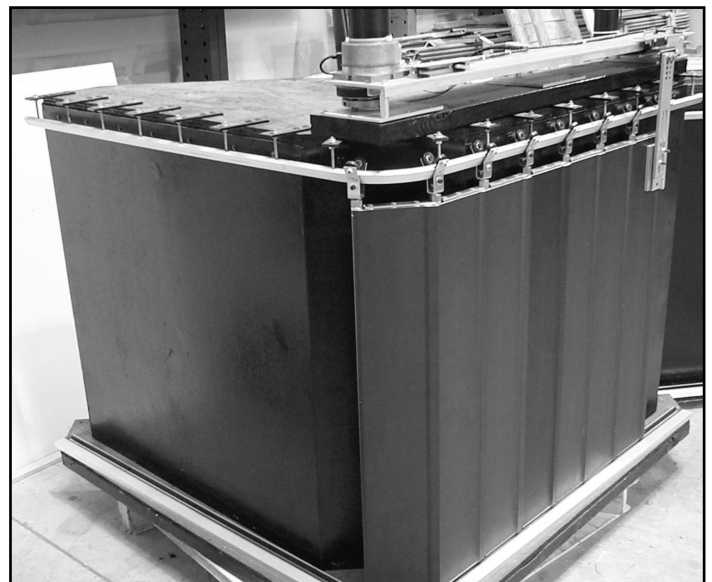

Wraparound Door Operator



Linear Drive Door Operator

EDUCATIONAL FOCUS: ELEVATOR DOOR OPERATORS

The application will vary according to customer needs. Microprocessor operators all operate on a 110VAC input power source. The different packages will have either 9VDC or a 90VDC door motor. The door-control board will then monitor the door motor and be able to accept either a 24VDC or 24VAC controller inputs or 110VDC or 110VAC controller inputs. Different or multi-voltage boards allow operator packages to be compatible with a variety of different main-elevator-controller company equipment.

The new generation of control boards for 90VDC motors will include all of the current code changes and any additional industry standards. The 90VDC operator package was used on a simulator and has exceeded one-million-cycle tests with an average open and close speed of less than two seconds without any shutdowns. Software and solid-state board design allows use of various inputs for an electronic edge, voltage limiter, current sensors, encoders and are factory preset for specifications. There are four adjustment pots for field adjustments. There is an optional hand-held programmable tool if needed. New software provides flexibility to make changes for different applications. New solid-state boards are roughly one half the size of the original solid-state boards.

Linear-motion or hydraulic door-operator packages are used on elevators with glass cabs or glass doors, extra-wide or extra-heavy doors, extra-tall doors, or for extra-wide, two-speed, or extra-wide, three-speed door openings. The wind in a lobby will not affect the operation because of the sealed oil system. The system is fabricated and tested to 600PSI for any leaks. Aircraft fire-retardant hoses are also used. Hoses are rated for up to 3000PSI. The system comes with standard relay-logic control boards. The two different types of linear or hydraulic drive door operators are 100VDC motor or three-phase 208VAC door motor. There is also a three-phase 380VAC motor for the Asian and U.K. market.

The linear-motion operator has a very low profile for elevators with limited overhead clearances. The pump can be mounted under the platform when necessary. This would require an inspection door in the platform.

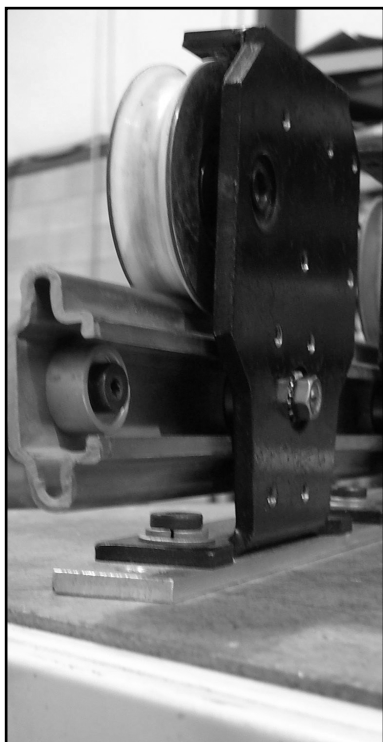

Ver-lok™ Hangers and Tracks

The 100VDC door-operator package is also available with an AC-to-DC rectifier that will convert the building power supply from 110VAC to the 100VDC power needed to operate the door motor. This system works very well when a standard hydraulic lowering system is installed in conjunction with the loss of building power. These packages come standard with relay-logic control boards. Different voltages are offered for relay-logic boards. The elevator controller manufacture will integrate with the boards with either 24VDC or 110VAC controller output voltages.

Door-operator packages can be obtained with vandal-proof hangers and tracks. These have an eccentric upthrust roller located inside the track system which prevents the doors from being knocked off the track, eliminating trouble calls on the door system.

Maintenance Requirements

The most common maintenance is to do a visual check of the entire system on regular maintenance visits. The way to keep the door-operator package working properly is to have every component free of all dirt, grease and oil. A clean and maintained system will increase the life of all the rollers, pulleys, cables and switches. This will also result in fewer callbacks. There may be some adjustments over time due to wear and normal use. Occasionally, the aircraft cable needs to be tightened or adjusted. This will keep all the components in proper alignment and also prevent future callbacks. Remember the money bumps on the tracks. The dirt buildup will keep those doors from closing that last half inch. The cleaning also applies to the electronic door edge, mechanical door safety edge and light rays. Dirt is your enemy and will keep your callbacks up.

Trouble-shooting Door Controller Boards

Door-operator packages come with an easy-to-understand wiring diagram. The standard voltmeter is the recommended

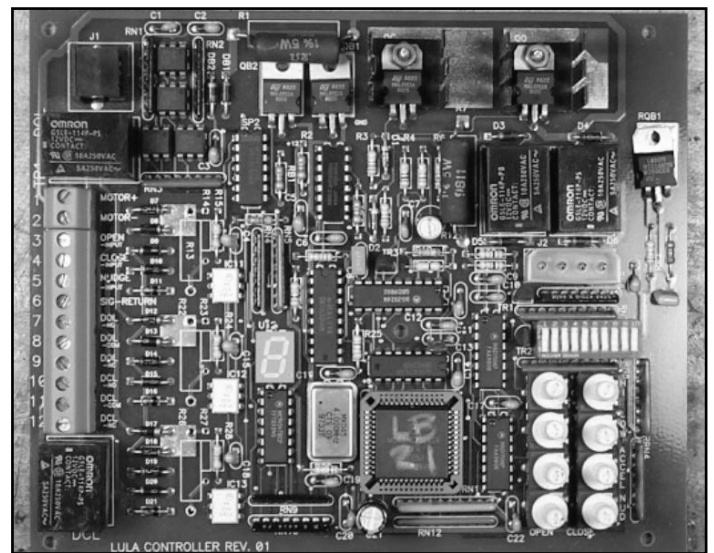

LULA Board

way to trouble-shoot this equipment. Power is taken to the control boards and converted from the building source or the power derived from an elevator controller. To simplify the trouble-shooting, three different types of door-operator controller boards are shown along with the AC/DC rectifier board and the proper way to trouble-shoot each board.

9VDC Door-Operator Package

The following trouble-shooting procedures are for LULA, residential, wraparound and medium-duty operator packages. The technician must take time to do a visual check of the board and all of its components. Most often, the problem is simple.

1. The first test would be a visual inspection of the entire system.
2. Then a visual inspection of the board. (See previous page.)
3. Verify that you have the proper power to the door-operator control board with your voltmeter.
4. Check to see that you have 12VDC on the power supply plug black and white wires.
5. Check the motor + and the motor - to see that you have the 12VDC available to operate the motor properly.
6. The simple test of the open- and close-door sensors will be to observe the LED readout. The proper operation will read 1, 3, 0, 4 and 2. This verifies that the door-open slow down #3 and full-door open sensor #1, the door-close slow down #4 and full-close sensor #2 are working properly. If you do not have any LED readouts, the cable from the sensors is not plugged into the control board. New design boards do not have the LED readouts, they have seven LEDs. The LEDs are on when the function they monitor is applied. They monitor door open (DO), door close (DC), open slow down (OS), close slow down (CS), full open limit (OL), full close limit (CL) and nudging signal (NUDGE).

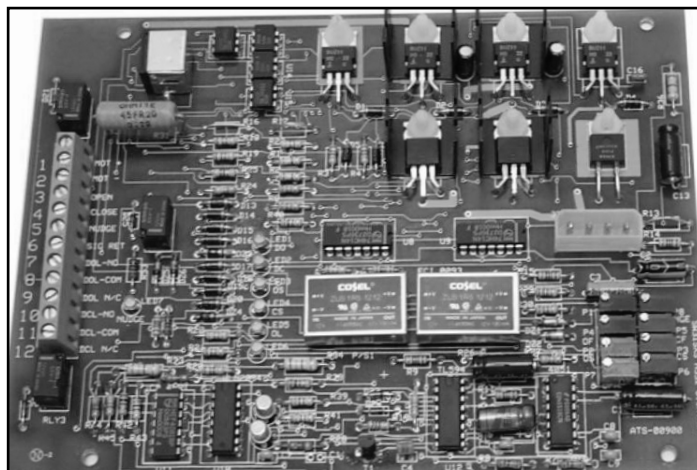

110VAC Board

7. The readout sensor test can be performed without the signals from the main elevator controller. Just plug the power supply cord into a standard 110VAC outlet. Manually open and close the car doors. Your signals will read 1,3,0,4

and 2. The open signals are #3 and #1 on the readout. The close signals are #4 and #2 on the readout. The "0" signal is the transition period from one set of limit sensors to the other set of sensors.

8. If controller inputs are not available at this time, you can still place the car doors on an automatic cycle by completing the following test. If you have the 110VAC controller input board, then attach the 110VAC common to the signal return #6 on the terminal strip. To open the doors, use the hot wire and touch the open input #3 on the terminal strip until the doors are fully open. To close the doors, touch the hot wire to close input #4 on the terminal strip until the doors are fully closed. If the signals show open and the car doors are trying to close, or vice versa, the motor rotation is reversed. If the rotation of the motor is opposite of the opening or closing cycle, just reverse the motor input leads on the back on the header.
9. Next, verify the voltage inputs from the controller match the proper board voltage. In this case, it would depend on which installation was used, the 24VDC or 24VAC board or the 110VDC or 110VAC board.
10. The control board test is done to verify all electrical and mechanical functions are working properly.
11. Check all of the mechanical functions of the doors, tracks, hangers or gibs.
12. Be sure there is nothing wedged into the sill.
13. Check to see that the door safety edge, light rays or the electronic door edge are all working properly.
14. It is recommended that all covers be reinstalled for a safe operation.

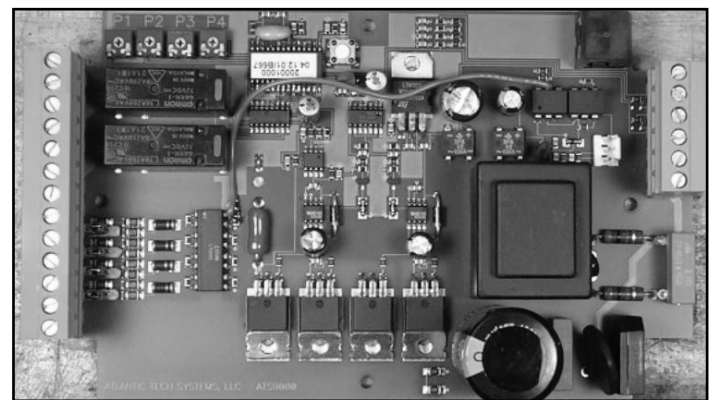

90VDC Board

90VDC Door-Operator Package

The following trouble-shooting procedures are for the 90VDC door-operator packages. Take time to do a visual check of the board and all of its components. Most often, the problem is simple.

1. The first test would be a visual inspection of the entire system.
2. Then a visual inspection of the board.
3. Verify that you have the proper power to the door-operator control board with your voltmeter.

EDUCATIONAL FOCUS: ELEVATOR DOOR OPERATORS

- Next, check to see that you have 110VAC on the power supply pins #18 and #19.
- Check the motor terminals #12 and #13 to see that you have the 90VDC available to operate the motor properly.
- A simple test of the open- and close-door sensors will check and verify the cable from the sensors is plugged in properly. This verifies that the door-open slow down and full-door open sensors, the door-close slow down and full-close sensors are connected.
- Next, verify that the voltage inputs from the controller are present and the voltage correct. In this case, it would depend on which board was installed, the 24VDC or 24VAC board or the 110VDC or 110VAC board.
- The control-board test is done to verify that all electrical and mechanical functions are working properly.
- Check all of the mechanical functions of the doors, tracks, hangers and door gibs.
- Be sure there is nothing wedged into the sill.
- Check to see that the door safety edge, light rays or the electronic door edge are all working properly.
- It is recommended that all covers be reinstalled for a safe operation.

These simple tests will verify that all components of the door operator package are properly working.

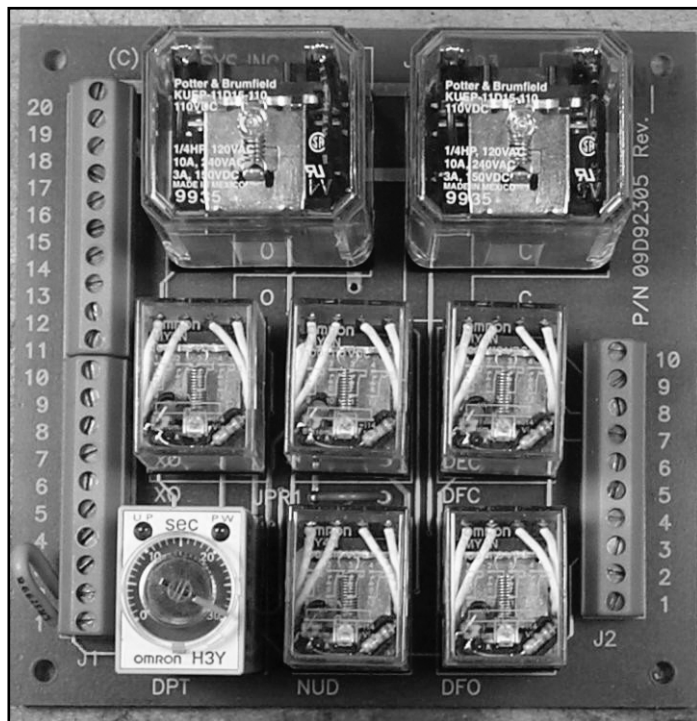

100VDC Board

Linear-drive 100VDC Door-Operator Package

Take time to do a visual check of the board and all of its components. Most often, the problem is simple.

- The first test would be a visual inspection of the entire system.

- Then a visual inspection of the board.
- The first test with your voltmeter would be to verify that you have the 100VDC on terminals DC+, J1 #15 and DC-, J1 #17.
- Check to see if the two power leads to the motor, terminals J1 #18 and #20 have power.
- Next, test the power to your micro switches on J1, #3-#11.
- Check the J2, #9 and #10 to see if the pump thermostat has power.
- Your main-controller inputs will be located on J2, #3-#7. Verify your controller voltages there.
- Check all of the mechanical functions of the doors, tracks, hangers and door gibs.
- Be sure there is nothing wedged into the sill.
- Check to see that the door safety edge, light rays and the electronic door edge are all working properly.

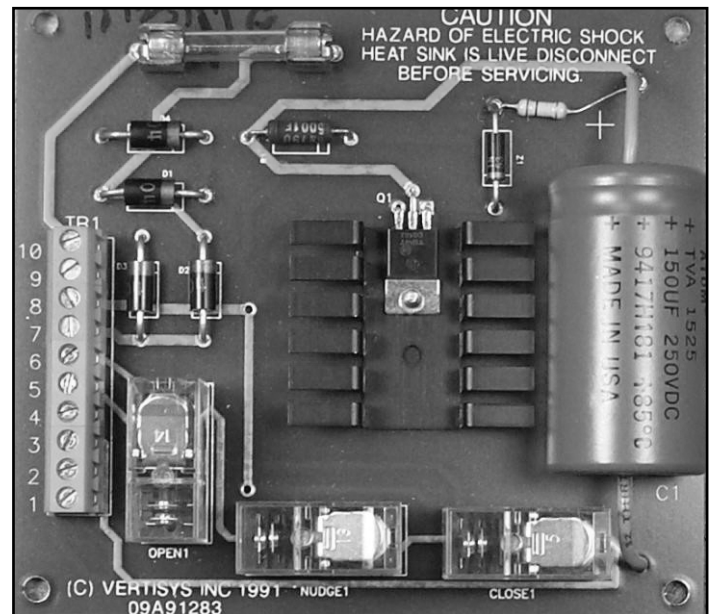

AC to DC Rectifier Board

- It is recommended that all covers be reinstalled for a safe operation.

These simple tests will verify that all components of the door operator package are properly working.

AC to DC Rectifier Board for the 100VDC Door Operator

The rectifier board will accept 120VAC power-source inputs and 120VAC main-elevator-controller signals. These signals are usually the OPEN, CLOSE and NUDGING signals. The rectifier board will output 117VDC power source and 117VDC control signals for OPEN, CLOSE and NUDGING signals. These signals will be sent to the door-operator controller. Take time to do a visual check of the board and all of its components. Most often, the problem is simple.

- The first test would be a visual inspection of the entire system.

2. Then a visual inspection of the board.
3. Next, check to see that 120VAC is present on terminals TB1-10 and TB1-9.
4. Verify that you have the 117VDC power output on terminals TB1-8 and TB1-7. Check to see that the power is present on our door controller terminals J1-12 and J1-14.
5. Verify the elevator controller OPEN input on terminal TB1-6.
6. Verify the elevator controller OPEN output on terminal TB1-5. This will input to the door controller on terminal J1-10.
7. Verify the elevator controller CLOSE input on terminal TB1-4.
8. Verify the elevator controller CLOSE output on terminal TB1-3. This will input to the door controller on terminal J1-11.
9. Verify the elevator controller NUDGING input on terminal TB1-2.
10. Verify the elevator controller NUDGING output on terminal TB1-1. This will input to the door controller on terminal J1-9.
11. This will complete all of the trouble shooting for the rectifier board.

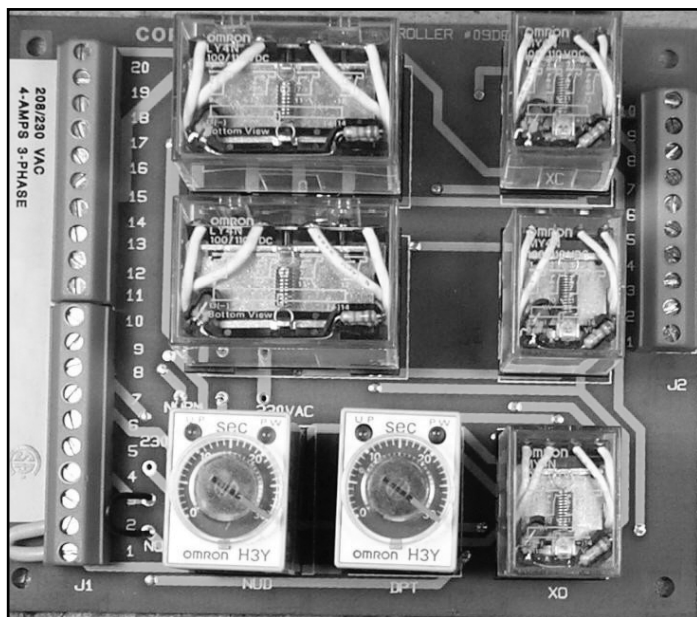

208VAC Board

Linear-drive 208VAC Three-phase Door-Operator Package

Take time to do a visual check of the board and all of its components. Most often, the problem is simple.

1. The first test would be a visual inspection of the entire system.
2. Then a visual inspection of the board.
3. The next test with your voltmeter would be to verify that you have the 100VDC on terminals DC+ , J1 #15 and DC-, J1 #17.

4. Next, check to see if the two power leads to the motor, terminals J1 #18 and #20 have power.
5. Test the power to your micro switches on J1, #3-#11.
6. Check the J2, #9 and #10 to see if the pump thermostat has power.
7. Your main controller inputs will be located on J2, #3-#7. Verify your controller voltages there.
8. Next check all of the mechanical functions of the doors, tracks, hangers and door gibs.
9. Be sure there is nothing wedged into the sill.
10. Check to see that the door safety edge, light rays or the electronic door edge are all working properly.
11. It is recommended that all covers be reinstalled for a safe operation.

These simple tests will verify that all components of the door operator package are properly working.

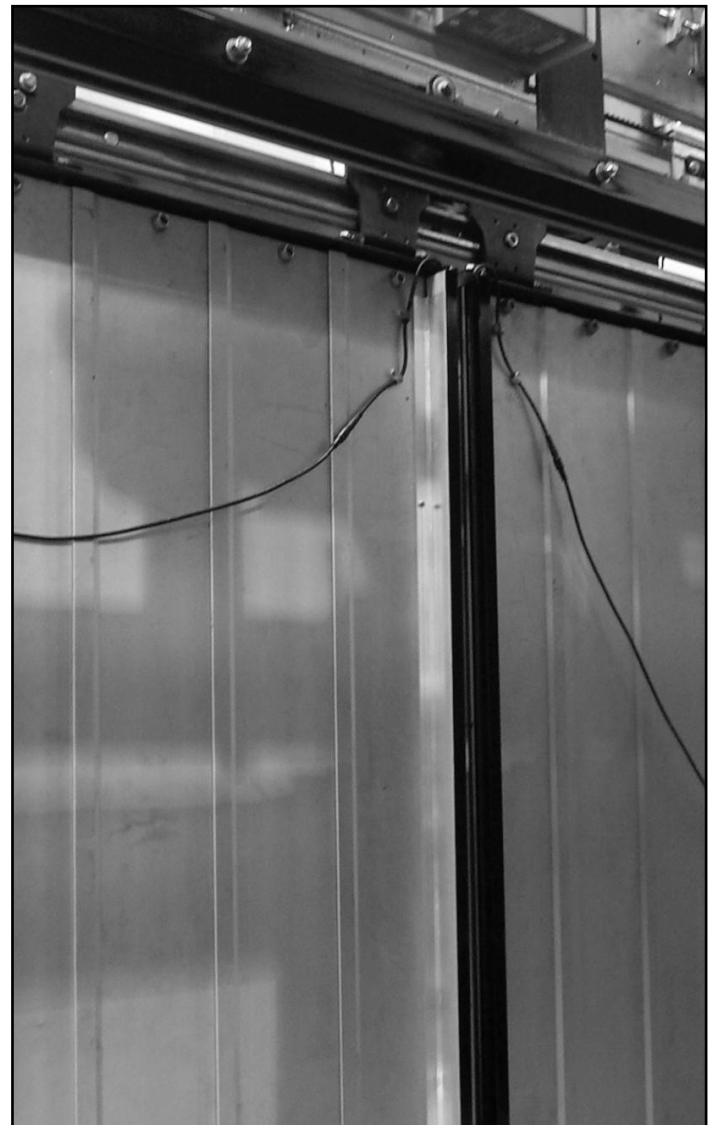

Electronic Door Edge

Electronic Door Edge

1. The first test would be a visual inspection of the entire system.
2. Check the power source and cords for the simple problems.
3. The electronic door edge is very simple to trouble shoot.
4. Check each terminal to be sure that the proper voltages are present.

Mechanical Safety Edge

1. The first test would be a visual inspection of the entire system.
2. Check the power source and cords for the simple problems.
3. Check to be sure that the edge is not in a mechanical bind.
4. Check the micro switches to see that they are working properly.

Electric Light Rays

1. The first test would be a visual inspection of the entire system.
2. Check the power source and cords for the simple problems.
3. Check to see if the beams are adjusted properly between the sender and the receiver.
4. Check to be sure the lens is clean and free of dust, dirt or a foreign substance.

For additional information, please contact the author at phone: (561) 586-1516 or e-mail: mikevondohre@atlantictechsystems.com 

Michael A. Von Dohre is CEO and president of Atlantic Tech Systems, LLC. He started his elevator career as a helper in Dayton, Ohio with Otis Elevator Co. for 12 years. He relocated to Orlando, Florida and joined the Otis team there. Von Dohre then spent the next 17 years with Montgomery and then KONE, Inc. He became the Service Sales and Modernization Sales manager in Orlando and was responsible for Walt Disney World, Universal Studios and Sea World accounts, as well as 120 miles of East Coast customers. He assisted all company technicians in solving customer door problems and callbacks.

Tony Cecere has been Mr. Quality Control and technical assistant to over 1,700 operators installed in over 47 countries.

Brad L. Fisher, treasurer and executive vice president also wears a manufacturing hat. He is responsible for overseeing all manufacturing operations. A special thanks goes to **Matthew B. Von Dohre** as our CAD designer and digital photographer.

PASSENGER ELEVATOR DOOR OPERATORS 101

by Doug Witham, G.A.L. Manufacturing

The proper selection, installation and adjustment of door-operating equipment is crucial to any modern elevator installation. With the possible exception of the elevator control itself, no other piece of equipment has as much potential for satisfying, or dissatisfying, an elevator contractor or building manager.

Selection

There are two major considerations – mechanical design and control design. You must be sure that the equipment selected has the capability to dependably and safely provide the door operation desired for your application.

Mechanical Design

Overview

All door panels on modern passenger elevators hang on rollers, which roll on tracks mounted at the top of the car or hoistway opening. At the bottom of the door panels, they are guided in the sill slot by door guides. Door guides, often referred to as “gibs,” normally have a plastic member, attached to the door panel, that moves in the sill slot. There is also a code requirement for a safety retainer on the bottom of the door.

There are two commonly used designs for driving door panels. One common design has an arm that reaches down and drives the door panel from a distance below the top (center-driven). The driving arm motion, using the mechanical advantage of the drive sheave and a pivot, produces a natural smooth acceleration and deceleration of the door panel (harmonic motion). The other common design drives the door panels from connections to the door hangers at the top of the door – often using either a belt or cable. These mechanical designs are often referred to as linear.

Center Driven, Harmonic Designs

Designs that are driven from the center of the panel are the best choice for the vast majority of applications. Although somewhat more complex, they offer more stability and a higher tolerance for less-than-ideal field conditions. Center-driven designs generally provide longer and more trouble-free operation. This design is much more capable of providing continued smooth operation when door panels are bent or canted, or when there is any resistance to free panel movement due to gibbs that are not perfectly free in the sill slots (Figure 1A). Additionally, due to the harmonic action of the drive, some acceleration and deceleration is generated mechanically. This makes door-motor control easier, because there is less actual motor speed change

necessary between high and low speeds and because the mechanical advantage results in more power at slow speed.

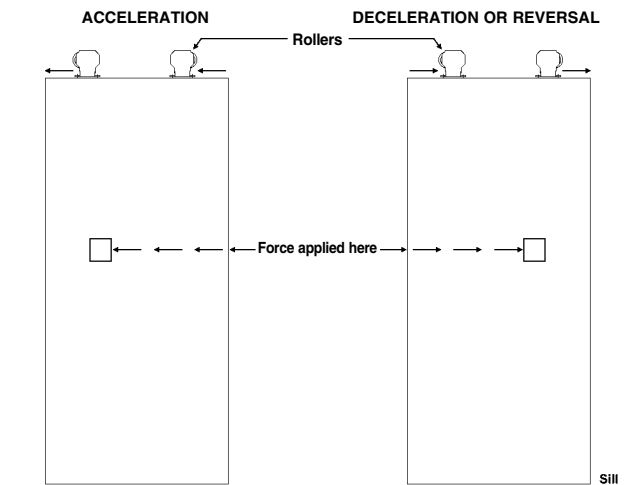

Figure 1A: Center-driven doors are inherently stable and more tolerant of less-than-perfect field conditions.

Linear Designs

Top-driven designs have been around for many years and appear to give lower manufacturing costs and perhaps reduced installation time. These advantages are often more than offset by lower performance and increased problems/callbacks. This is due to their tendency to rock and cock during any swift acceleration or deceleration. This is especially true if there is a quick door reversal or any resistance to door-panel movement resulting from gib-to-sill contact.

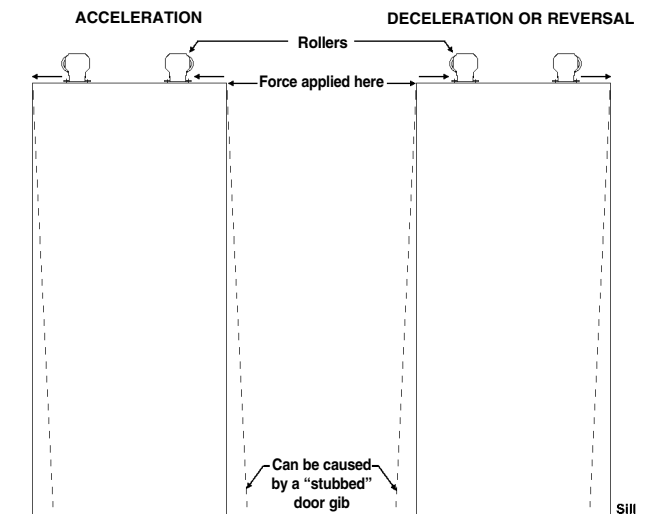

Figure 1B: By their nature, top-driven doors are prone to rock and cock during swift acceleration, deceleration and especially during any quick reversal.

This instability becomes a greater problem with narrow door panels, as would be common in two-speed setups (Figure 1B). Additionally, a much wider control of door-motor-speed control is required, making accurate control more problematic.

Control Design

Overview

Control design has evolved over the years. Ignoring early AC designs with no, or minimal, resistance control, door-operator-control systems have fallen into one of three categories. They are cam and contact resistance controls, cam and contact solid-state controls, and closed loop/variable voltage variable frequency (VVVF) controls.

Cam and Contact – Resistance

Before solid-state power control was available or the cost to provide this was reasonable, most door operators had resistance control. Using various cam-operated contacts to insert and/or remove power resistors, both in parallel and in series with the door motor armature, these operators could adjust the speed and force of the door movement.

Cam and contact resistance controls have been the mainstay for door operators in North America for many years. They are usually less expensive than more sophisticated controls. They remain a very popular choice, because of their lower cost. Cam and contact controls have proven dependable and more than capable of providing excellent door operation, but they require more knowledge and time to set up and maintain. These designs cannot produce the consistency from floor to floor that comes with closed-loop controls.

Cam and Contact – Solid State

These designs became popular after the advent of economical solid-state power devices. They employed the same basic cam setup for switching, but the cams were used to change the operation of solid-state circuits, as opposed to switching power resistors. To the extent that the DC motor armature was supplied pulsed DC, with a high pulse rate, they could achieve good, basic door-speed control.

These operators had the advantage of solid-state control, but still had the maintenance always associated with the mechanical cams. Their higher price (as compared to resistance controls) was seen as offset by more consistent control. Without the extra cost of special circuitry, these operators did not cope well with special door conditions such as heavy lobby doors or variations in hoistway-and-lobby wind pressure.

Closed Loop/VVVF

Closed loop/VVVF controls are now available and are being specified by many consultants. They are quickly becoming the choice for many of today's applications. With VVVF control, door speed, acceleration, deceleration, torque, reversal and any number of other parameters are easily and

completely controlled. Mechanical cams have been replaced with non-contact optical couplers. This substantially reduces maintenance. With a closed-loop design, you get consistent door operation from floor to floor, despite differences in door weight and varying resistance to panel movement due to setup or wind conditions.

These controls are state-of-the-art for door operators and have all but made obsolete earlier solid-state designs. They are more expensive than the cam and contact resistance controls, but their higher price is often offset by reduced time for installation, adjustment and maintenance.

What is closed loop, and why is it desirable? The term "closed loop" is used to describe a system that is capable of adjusting the real-time operation to match the prescribed operation. A closed-loop system will measure the real performance, compare it to the programmed performance and adjust, adding or reducing power, torque, acceleration, deceleration, etc., so that the system always performs to the prescribed level.

A quick and easy way to check if your control system is closed loop:

- ◆ Using a stopwatch, time the open or close cycle of your doors.
- ◆ Disconnect the hatch door(s) – this reduces weight substantially.
- ◆ Again, time the open or close cycle
- ◆ A closed-loop system will operate with no noticeable difference in cycle time.

Closed-loop performance is very desirable, especially in high-rise applications where just the wind difference, floor to floor, can result in a great deal of difference in door performance.

Installation

Once you have selected the mechanical and control design that best suits your needs, the issue becomes installation. It's worth mentioning here that all door-operator manufacturers can, and will, provide equipment that is easy to install, but their ability to do this depends entirely on the data that is provided to them and to the cab and/or door manufacturer. This is a critical point – the most problematic door-operator installations almost always begin with inaccurate or incomplete data being supplied. All manufacturers are happy to supply you with a job survey form – the time taken to fill it out accurately is well spent.

Every manufacturer is different, and it would be impossible to provide all of the detail necessary for installation from A to Z. This article makes no attempt to be a substitute for an installation manual. All manufacturers will include the necessary details with the operator.

EDUCATIONAL FOCUS: ELEVATOR DOOR OPERATORS

This much being said, the keys to a good door-operator installation are applicable no matter the design. In normal sequence, and using the G.A.L. product for the example, the major steps are:

- ◆ Mount the hoistway door tracks in position at each floor using the holes provided by the header manufacturer*. Eccentric cams should be set so that the track is in the lowest possible position (Figure 2). NOTE: Code restricts the space between door and jamb to a maximum of 3/8 inches (G.A.L. recommends 1/4in.) shim as necessary to attain this dimension (Figure 3).

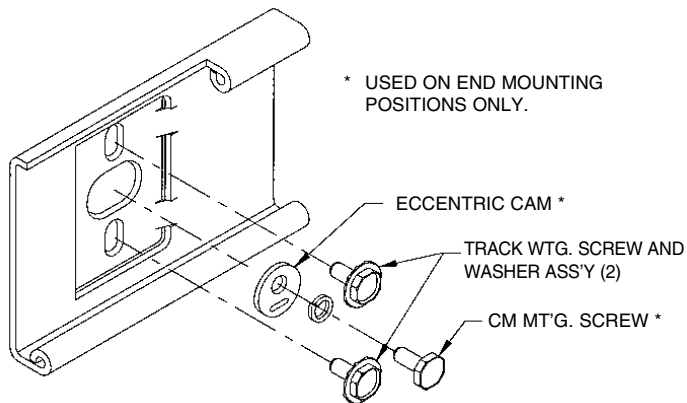

Figure 2: Set eccentric cams in the lowest possible position.

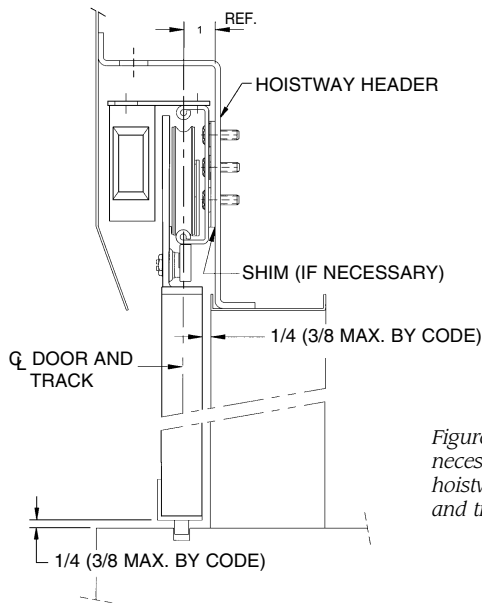

Figure 3: Shim as necessary between hoistway header and track.

- ◆ On modernization projects, where existing hoistway headers are being maintained, it is often necessary to drill and tap the header to match the hole pattern on the track. The installation mechanic will need the appropriate drills, taps and power tools.

- ◆ Bolt the sheave assemblies on, using holes provided by the door manufacturer, and hang the hoistway doors. When hung, the track eccentrics are turned, raising or

lowering each end of the track, to attain a desirable and consistent (3/8in. maximum per code) door-to-sill dimension. Door panels should be plumb, and door movement should be unrestricted. Doors should, without resistance, glide open and close.

Two Notes:

1. If, after achieving the required dimension from the bottom of the door to the bottom of the sill slot, the door(s) is/are misaligned, it is best corrected by placing a shim between the hanger assembly and the top of the door (Figure 4).

2. Code requires a primary and a secondary means of roller retention. Once the doors are properly adjusted, set each upthrust roller (primary retention) to within 1/64in. of the bottom of the track. The safety retainer (secondary retention) must now be pivoted back into position and tightened (Figure 5).

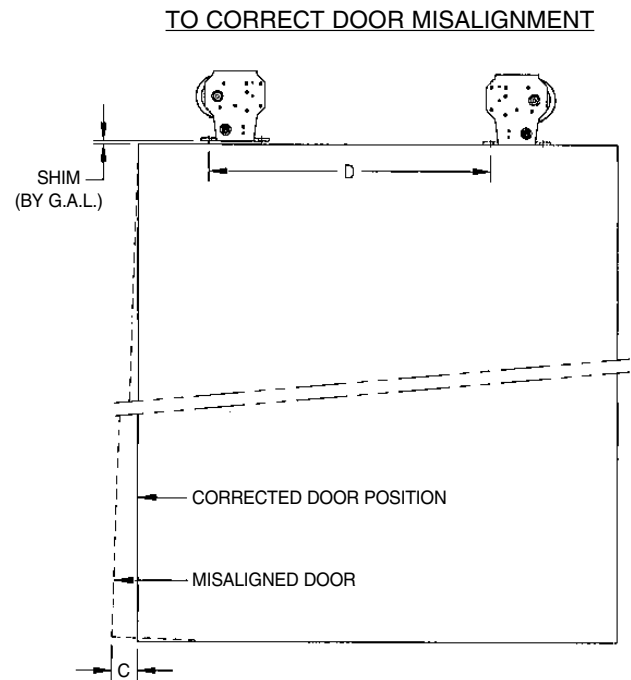

Figure 4: To correct door misalignment

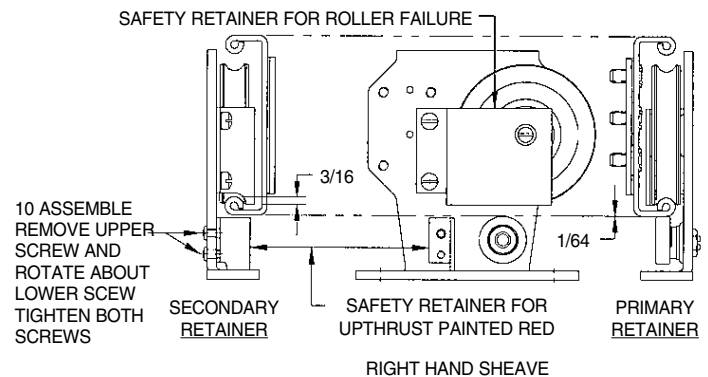

Figure 5: Primary and secondary retainers

A Common Mistake

Reel closers, and/or sill-mounted spring closers, are required by code so that when the car and hoistway doors are disengaged, the hoistway doors will automatically close. One of the biggest mistakes that we see in installation is the attempt to overpower a binding door panel by increasing tension on the closer. Doors should glide freely both open and closed. If the door has to “fight” against an over-tensioned closer, this will result in premature failure of operator components and increased maintenance.

- ◆ Mount the car header and track using the header supports and shims provided by the cab manufacturer*. The considerations, procedures and techniques used here are the same as for the hoistway tracks (Figure 6).

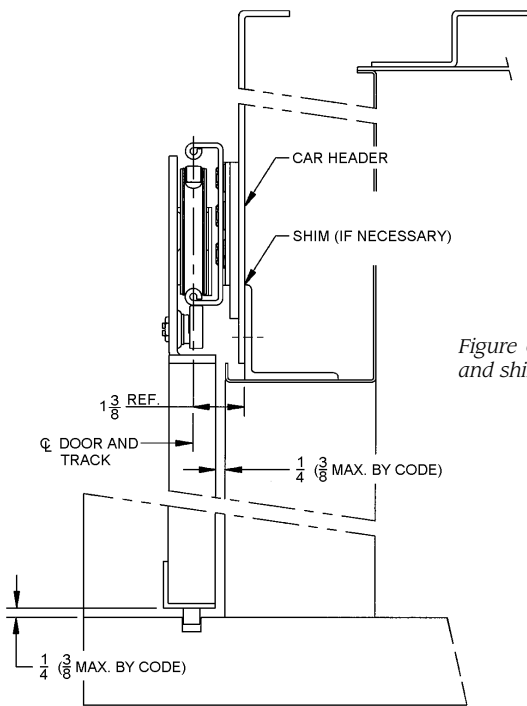

Figure 6: Car header and shim

- ◆ On modernization projects, where the existing header is being maintained, the installation mechanic should be prepared to make any necessary adjustments. If given the complete information on the survey form, the manufacturer can minimize any difficulties here.
- ◆ Position and mount the operator. There are way too many variations to try to detail them in this article – suffice it to say that you should carefully follow the manufacturer’s instructions.

Mechanical Adjustment

Again, there are just too many variations here to attempt to cover all of the aspects of mechanical adjustment. Manufacturers’ will provide all the detailed information necessary.

There is one key when adjusting the harmonic, center-driven designs that is often misunderstood and is worthy of a detailed explanation. If, after operator installation, the door(s) do not open and close to their proper position, there are two possible adjustments – and here is the rule to remember: The crank arm length determines the total travel of the door(s), and the connecting link length determines the door position (Figure 7).

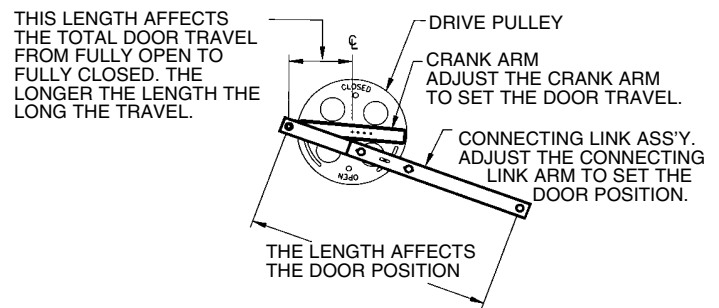

Figure 7: Crank arm length

The normal adjustment procedure would be to:

- ◆ Disconnect the connecting link from the operator.
- ◆ Manually move the door to the fully closed position.
- ◆ Re-attach the connecting link in this position.
- ◆ By turning the drive sheave, manually move the doors to the full-open position.
- ◆ If the door is short of or past where it should be at fully opened, shorten or lengthen the crank arm to adjust the travel.

NOTE: It’s possible, if substantial crank arm adjustment was necessary, that you will have to again reset the connecting link.

For the sake of simplicity, a side-opening door is shown in Figure 7. If you were going through this procedure on center-opening doors, there are two other issues.

- ◆ The driven side (clutched side) should always be adjusted first.
- ◆ Instead of starting at the fully closed position, you would just make a mark on the sill in the place where the doors should meet.

NOTE: It’s normal for the car doors to meet slightly off center – pay close attention to the manufacturer’s instructions, and be sure to take this into account when marking the sill.

Control Adjustment

When considering control adjustment, it’s useful to look at typical opening and closing cycles as they are shown in Figures 8 and 9. There are two aspects of door operation that can be adjusted to fine tune door operation. The first is the place in the cycle where any given function is activated or deactivated (A/D point), and the second is the magnitude (most easily understood as power) that is associated with each.

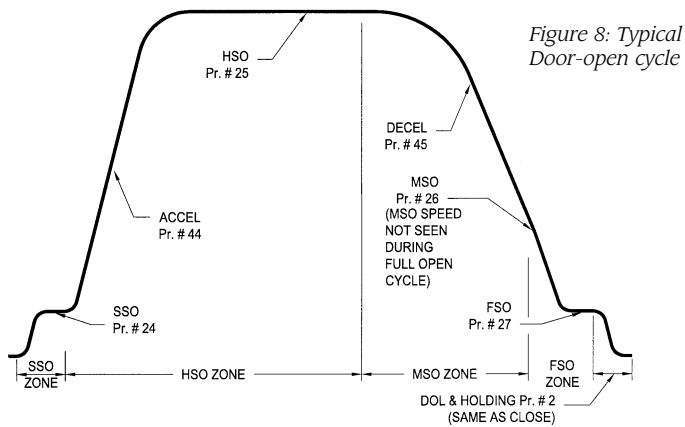

Figure 8: Typical Door-open cycle

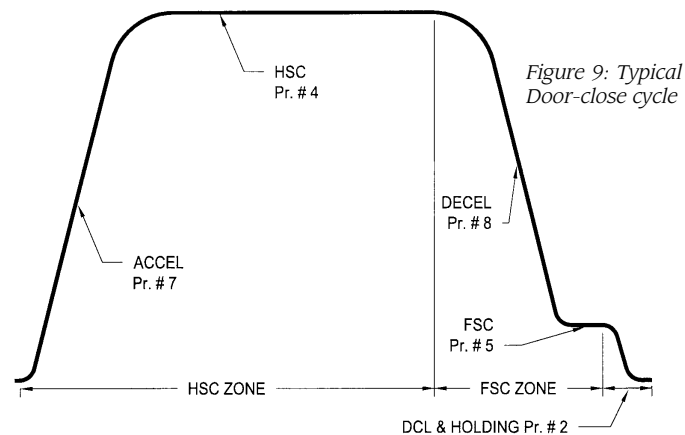

Figure 9: Typical Door-close cycle

All operators leave the factory pre-adjusted. The A/D points and the magnitude of each function will be set so that the operator will perform in an acceptable average fashion. Site conditions, elevating philosophy or the needs of specific applications might make some changes desirable. Certainly, door movement in a nursing home should be different from that in a high-rise office building. Be mindful of the code requirements for closing force and kinetic energy when attempting to maximize door speed.

Cam and Contact (Resistance) Control Adjustment

Cam and contact operators cannot be as closely or easily controlled as those with VVVF drives. An experienced mechanic, even though there are fewer adjustable functions, can still fine tune these operators to a great degree.

On a cam and contact operator, the A/D point is adjusted by loosening a cam, repositioning it and retightening it, so that it will operate the associated contact at the proper point during the cycle. This can sometimes be done with a “feel” or a little trial-and-error. On some designs, all of the close-cycle cams and/or open-cycle cams are pinned together. On these designs, A/D points, within either cycle, are not adjustable.

Likewise, adjusting the magnitude of a function requires either some experience or a couple of tries. It is accomplished by sliding adjustable bands up or down on large resistors. The key to adjusting here, especially if the door movement is restricted anywhere during the cycle, is to assure smooth,

quiet movement, without slamming, and still staying within the code requirements for closing force and kinetic energy.

Cam and Contact (Solid State) Control Adjustment

The A/D points on these designs are very much like and have the same issues associated with those discussed above. Speed and/or force is adjustable with small potentiometers as opposed to power resistors.

Closed Loop/VVVF Adjustment

Ease of adjustment, and almost complete controllability, are two of the reasons that VVVF designs have gained so much popularity with mechanics. With this type of control, operators often leave the factory and are never touched.

Precise A/D points can be established with the aid of LED indicators on the operator’s circuit board. A switch on the operator is thrown to interrupt power to the motor. By turning the drive sheave, the doors are manually positioned, and then friction fit cams can be moved until the LEDs show that the exact A/D point is set.

Likewise, the magnitude adjustments are very easy. It’s done by keying changes into a keypad on a hand-held parameter unit. With this tool, a mechanic can watch door operation, while adjusting all speeds, torques, acceleration and deceleration. A single chart (Figure 10) can be used to explain the LED pilot lights, cams, parameter settings and the effects of adjustment.

A Note on Electrical Grounding

NFPA-70 contains the code requirements for the grounding of electrical devices. VVVF are especially prone to having and/or causing problems, if not properly grounded. Be sure to follow the manufacturer’s instructions. It is often necessary to ground the motor and the circuit board separately.

Other Features of Modern Door Operators

Download/Upload for Multi-Car Groups

When fine tuning the door operation of two or more cars that are all intended to perform the same, a lot of field time can be saved if the operator has this feature. It is easy to download the parameters from the first car into a hand-held parameter unit. The unit can then be plugged into the next car, and the parameters can easily be uploaded to that operator – presto, two cars with identical door operation. If the operator has this feature, it takes only marginally more time to fine tune six cars than it does to do one.

Current Limiting Circuitry

Due to the VVVF drive’s ability to monitor an increase in current, they can add another level to door safety. An adjustable parameter can be set that will trigger a reversal if the doors encounter resistance from something in their path. Photo eyes and light curtains are very effective protection for objects that obstruct the car doors. Properly adjusted, current limiting circuitry can provide a increased safety factor for objects that are in front of only the hoistway doors.

EDUCATIONAL FOCUS: ELEVATOR DOOR OPERATORS

Ease of Troubleshooting

This is actually more a function of being solid state than being VVVF, but it can save a lot of field time. The best of these types will have a circuit board with LED indication of operator status. Troubleshooting is easy when you have visual indication of all inputs to and outputs from the door operator. A good example is you find that your doors are reversing when part way through a close cycle. With LED indication, you will instantly know what is triggering this function – the elevator control, the electronic edge, the current-limiting circuitry or possibly a G.A.L. fault monitor (if installed).

Plug-and-Play Door Protection

Again, an operator would not really need to be VVVF to have this feature, but it will probably have to be solid state (all VVVF operators will be solid state, but the opposite is not necessarily true). To the best of your author's knowledge, G.A.L.'s MOVFR operator is the only model to offer this feature. With this advantage, when the door protection is also purchased from G.A.L., the time and expense of locating, mounting and wiring a separate power supply for light curtains can be completely eliminated. Edges, made by any of the major suppliers (Adams, Formula Systems, Janus, T.L. Jones or Tri-Tronics), can be simply plugged into a pair of sockets on the operator.

Conclusion

Like all things on an elevator, door operators are in a con-

stant state of evolution. Designs have come and gone, and will continue to do so as manufacturers and contractors experiment with and employ new technologies and methods. This article was intended to be just a brief overview of the equipment available today, and some of the common issues that surround selection, installation and adjustment.

There are many different designs of passenger elevator door operators available. The contractor, considering design and price, must select the equipment that is best suited to the specific application. The manufacturer, given complete and accurate jobsite details, should provide equipment that installs and adjusts easily. When these few requirements are met, a building owner can expect many years of safe, dependable and trouble-free elevator door operation.

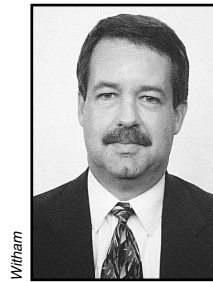

Doug Witham is vice president of Sales and Marketing for G.A.L. Manufacturing Corp. A graduate of Ohio State University, Witham began his career in the industry with Gregory Elevator in Chicago. In 1977, he moved to Adams Elevator Equipment Co. for 18 years. Prior to joining G.A.L., Witham was a vice president with Courion. He has been an officer with the Chicago Elevator Association, a director and treasurer with the National Association of Elevator Contractors and a regent with the Elevator Escalator Foundation of Canada.

Figure 10: Closing and opening functions

Table of closing functions:

CLOSING FUNCTION	LED PILOT LIGHT	Pr. No	PARAMETER RANGE	FACTORY SETTING		HIGHER SETTING	CAM CHANNEL SETTINGS			DISTANCE ACTIVATED
				C/P	S/O		○ OPENED	● BLOCKED		
Holding torque	--	0	0 - 30%	3	3	Higher holding amps				
Torque	--	3	0 - 400HZ	225	175	Lower running torque				
Acceleration	--	7	0 - 360s	6	6	Longer accel time				
Deceleration	--	8	0 - 360s	10	10	Longer decel time				
High speed	HSC	4	0 - 400hz	23	19	Faster speed	○	○	○	Until 4in. from final close
Final speed	FSC	5	0 - 400hz	6	5	Faster speed	●	○	○	Last 4in. of close range
Fault monitor	DPM	--	--	--	--	--	●	●	○	Just before gate switch is activated
Holding speed	HOLD & DCL	2	0 - 120hz	2	2	Stronger holding power	●	●	●	1/4in. from close stop roller
Nudge speed	NUDG	6	0 - 400hz	11.5	9	Faster speed				

Table of opening functions:

OPENING FUNCTION	LED PILOT LIGHT	Pr. No	PARAMETER RANGE	FACTORY SETTING		HIGHER SETTING	CAM CHANNEL SETTINGS			DISTANCE ACTIVATED
				C/P	S/O		○ OPENED	● BLOCKED		
Slow speed torque	--	46	0 - 30%	0	0	Higher torque				
Torque	--	47	0 - 400HZ	80	80	Lower running torque				
Acceleration	--	44	0 - 360s	4	4	Longer accel time				
Deceleration	--	45	0 - 360s	9	10	Longer decel time				
Slow start	SSO	24	0 - 400hz	5	5	Faster speed	●	○	○	First 1/2 inch of opening
High speed	HSO	25	0 - 400hz	45	45	Faster speed	○	○	○	1/2 inch to 3/4 open
Med speed	MSO	26	0 - 400hz	20	20	Faster speed	○	●	○	Last 1/4 of opening
Final speed	FSO	27	0 - 400hz	5	5	Faster speed	●	○	●	Last 4in. of open
Holding speed	HOLD & DOL	2	0 - 120hz	2	2	Stronger holding power Note: This is the closing Parameter.	●	●	●	1/4in. from close stop roller
Quick stop	REOPEN	12	0 - 30%	1	15	Quicker stop				
Stall rev.force	REOPEN	150	0 - 200%	40	40	Stronger stall force				