



EDWARDS INTUITY Elite Valve System Aortic Valve, Model 8300AB Delivery System, Model 8300DB

Instructions for Use

Caution: Federal (USA) law restricts this device to sale by or on the order of a physician.

For single use only

1.0 Device Description

1.1 General

The EDWARDS INTUITY Elite valve system consists of the EDWARDS INTUITY Elite valve, model 8300AB and the EDWARDS INTUITY Elite delivery system, model 8300DB.

The pericardial stented aortic valve is based on the design and the proven performance of the PERIMOUNT valve family. A balloon expandable stainless steel cloth-covered frame is incorporated into the inflow aspect of the valve. The valve is implanted with the aid of a delivery system, which incorporates a balloon catheter to expand the frame within the left ventricular outflow tract (LVOT). The expandable frame works in conjunction with the sewing ring to position and stabilize the valve at implant. The system reduces the number of sutures required to secure the valve, while the frame establishes a seal within the LVOT. The system may be used in both traditional and less invasive surgical procedures for heart valve replacement.

1.2 EDWARDS INTUITY Elite Valve

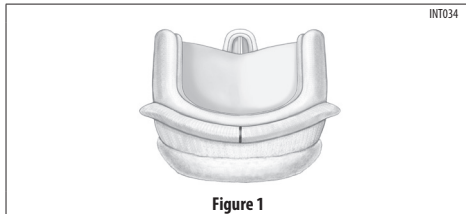

Figure 1

The model 8300AB (Figure 1) is a stented trileaflet valve comprised of bovine pericardium treated with the Carpentier-Edwards TheraFix process. The leaflets are mounted on a flexible cobalt-chromium alloy wireform. The inflow of the valve incorporates the cloth-covered balloon expandable frame. The EDWARDS INTUITY Elite valve system is available in sizes 19, 21, 23, 25, and 27 mm (Table 1).

Edwards, Edwards Lifesciences, the stylized E logo, Carpentier-Edwards, EDWARDS INTUITY, EDWARDS INTUITY Elite, PERIMOUNT, TheraFix and TRANSFORM are trademarks of Edwards Lifesciences Corporation. All other trademarks are the property of their respective owners.

Table 1: Nominal Dimensions (mm) EDWARDS INTUITY Elite Valve

Size	19 mm	21 mm	23 mm	25 mm	27 mm
A. Internal Diameter	18	20	22	24	26
B. Profile Height	13	14	15	16	17
C. External Sewing Ring Diameter	24	26	28	30	32
D. Stent Diameter (wireform)*	19	21	23	25	27

*TAD (Tissue Annulus Diameter)

Note: for sizing, refer to **Section 8.3 "Sizing"**

The valve is packaged and terminally sterilized in glutaraldehyde. Glutaraldehyde is shown to both reduce the antigenicity of tissue xenograft valves and increase tissue stability (Refs. 1 & 2).

The wireform is made of cobalt-chromium alloy. The wireform is covered with a knitted polyester fabric. A thin, cobalt-chromium alloy/polyester film laminate band surrounds the base of the wireform. A silicone sewing ring which is covered with a porous, seamless polytetrafluoroethylene (PTFE) cloth is attached to the wireform. The scalloped sewing ring is designed to conform to the native aortic annulus. The compliant nature of the sewing ring facilitates coaptation between the valve and an often irregular or calcific tissue bed. The sewing ring has three suture markers to aid in valve orientation.

A holder is attached to the valve by means of sutures to facilitate handling, deployment, and suturing the valve during the implant procedure. The holder is easily detached by the surgeon. (Refer to Section 8.4 "Preparation Instructions").

1.3 Delivery System and the Inflation Device

The EDWARDS INTUITY Elite delivery system model 8300DB is designed to introduce and deploy the model 8300AB valve. A delivery system is available for each size of the aortic valve.

The delivery system includes an integrated balloon catheter and malleable tubular handle shaft through which the catheter extends. The distal end of the handle shaft includes an adapter, which mates with the holder of the valve, and a locking sleeve for rapidly connecting the delivery system to the valve holder. The balloon

portion of the delivery system resides within the adapter, and advances distally into position for expanding the frame. A tubular balloon introducer is attached, when removing the valve from a storage jar, and facilitates passage of the balloon through the valve (Figure 2). The malleable handle is made of aluminum and has chromate conversion coating applied over the entire surface of the part.

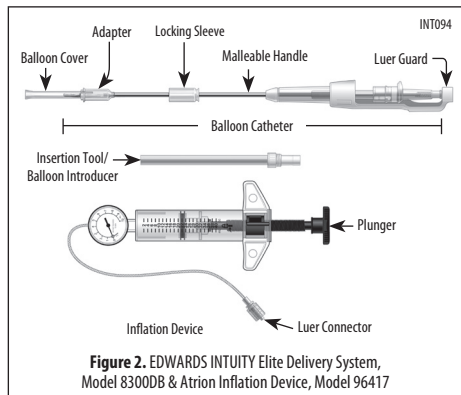

Figure 2. EDWARDS INTUITY Elite Delivery System, Model 8300DB & Atrion Inflation Device, Model 96417

The inflation device is used to pressurize and expand the balloon. Refer to the inflation device manufacturer Instructions for Use for additional information.

2.0 Indications for Use

2.1 EDWARDS INTUITY Elite Valve, Model 8300AB

The EDWARDS INTUITY Elite valve is indicated for the replacement of diseased, damaged, or malfunctioning native or prosthetic aortic valves.

2.2 EDWARDS INTUITY Elite Delivery System, Model 8300DB

The delivery system is indicated for introduction of the valve into the patient's native annulus.

3.0 Contraindications

3.1 EDWARDS INTUITY Elite Valve System

The model 8300AB valve is contraindicated for patients with the following conditions:

- Pure aortic insufficiency
- Aneurysms of the aortic root or ascending aorta

3.2 EDWARDS INTUITY Elite Delivery System

The model 8300DB delivery system is contraindicated for use with valves other than the model 8300AB. It is also contraindicated for use in valvuloplasty.

4.0 Warnings

4.1 Device Handling

These devices are designed, intended, and distributed for single use only. Do not re-sterilize or reuse this device. There are no data to support the sterility, nonpyrogenicity, and functionality of these devices after reprocessing.

DO NOT RESTERILIZE THE VALVE OR DELIVERY SYSTEM BY ANY METHOD.

Exposure of the valve, container, or delivery system to any sterilization method will render the valve or delivery system unfit for use.

DO NOT USE the valve or delivery system if the expiration date has elapsed.

DO NOT EXPOSE the valve or delivery system to any solutions, chemicals, or antibiotics, except for the storage solution or sterile physiological saline solution. Irreparable damage to the leaflet tissue, which may not be apparent under visual inspection, may result.

Care should be exercised in patients with hypersensitivities to metal alloys that contain cobalt, nickel, chromium, molybdenum, manganese, carbon, beryllium, and iron.

4.2 Environmental

DO NOT FREEZE OR EXPOSE THE VALVE TO EXTREME HEAT. Exposure to extreme temperatures will render the device unfit for use.

DO NOT USE the valve if the tamper evident seal on the jar is broken.

DO NOT USE the valve system if the tamper evident band is broken.

DO NOT USE if the packaging seal is broken or if the packaging is damaged.

DO NOT USE if the EDWARDS INTUITY Elite delivery system is damaged.

4.3 Clinical Warnings

The safety and effectiveness of the valve has not been established for the following specific populations because it has not been studied in these populations:

- Patients who are pregnant or lactating
- Patients with chronic renal impairment or calcium metabolism disorders
- Patients with active endocarditis or myocarditis
- Children or adolescents

As with any implanted device, there is potential for an immunological response.

Use of the EDWARDS INTUITY Elite valve system may be associated with new or worsened conduction system disturbances, which may require a permanent cardiac pacemaker implant.

Serious adverse events, sometimes leading to replacement of the valve and/or death, may be associated with the use of prosthetic valves (see Section 6.0 "Potential Adverse Events"). A full explanation of the benefits and risks should be given to each prospective patient before surgery.

4.4 Post-Operation Management

It is recommended that prophylactic antibiotic therapy be given to patients undergoing dental or other procedures which are potentially bacteremic in order to minimize the risk of endocarditis.

Some medical professional societies recommend anticoagulant therapy, unless contraindicated, during the first 3 months after bioprosthetic aortic valve implantation. Such postoperative anticoagulant therapy should be determined on an individual basis.

Long-term low dose aspirin, unless contraindicated, is recommended for all patients with bioprosthetic valves. Long-term anticoagulant therapy, unless contraindicated, is recommended for all patients with bioprosthetic valves who have risk factors for thromboembolism.

Careful and continuous medical follow-up is advised so that valve related complications can be diagnosed and properly managed.

5.0 Precautions

Clinical data that establish the safety and efficacy of the valve for use in patients under the age of 20 are not available; therefore, careful consideration of its use in younger patients is recommended.

Based on reports in the literature on tissue valves (Refs. 3, 4, 5, 6, 7, 8), there appears to be an increased incidence of leaflet calcification in patients under the age of 20. When feasible, repeated intravenous injections containing calcium should be avoided during the postoperative period, and excessive milk or dairy product consumption should be avoided in children.

Animal research studies (Ref. 6) show that a high systemic calcium level can lead to early calcification.

Glutaraldehyde may cause irritation of the skin, eyes, nose, and throat. Avoid prolonged or repeated exposure or breathing of the solution. Use only with adequate ventilation. If skin contact occurs, immediately flush the affected area with water; in the event of contact with the eyes, seek immediate medical attention. For more information about glutaraldehyde exposure, please refer to the Material Safety Data Sheet available from Edwards Lifesciences.

6.0 Potential Adverse Events

As with all prosthetic heart valves, serious complications, sometimes leading to reoperation, other re-intervention, explantation, or death, may be associated with the use of bioprosthetic valves. In addition, complications due to individual patient reaction to an implanted device, or to physical or chemical changes in the components, particularly those of biological origin, may occur at varying intervals (hours or days) necessitating reoperation and replacement of the prosthetic device. Adverse events (in alphabetical order) potentially associated with the use of bioprosthetic heart valves and aortic valve replacement surgery include but are not limited to:

- Allergic reaction to valve materials
- Anemia, including hemolytic anemia
- Annulus damage, dissection, or tear
- Aorta damage, dissection, or tear
- Coagulopathy
- Hemolysis
- Hemorrhage
- Blood pressure alteration (hypotension, hypertension)
- Cardiac arrest/Asystole
- Cardiac arrhythmias/conduction disturbances (new or worsened)
- Cardiac failure (heart failure)
- Chordae tendineae damage (mitral valve)
- Coronary artery ostia blockage
- Death
- Endocarditis
- Explantation
- Infection - Local and/or Systemic
- Leaflet impingement (aortic or mitral valve)
- Left ventricular outflow tract damage
- Myocardial infarction (MI)
- Neurologic Events
 - Stroke
 - Transient ischemic attack (TIA)
- Nonstructural valve dysfunction
- Patient-prosthesis mismatch (PPM) (due to inappropriate sizing)
- Pericardial effusion or tamponade
- Reduced exercise tolerance/shortness of breath
- Reoperation or Re-intervention
- Structural valve dysfunction/deterioration
 - Calcification
 - Fibrosis
 - Leaflet tear or perforation
 - Valve stent fracture
 - Valve stent separation
 - Annulus frame fracture

- Annulus frame separation
- Tissue dehiscence
- Tissue leaflet damage (from instruments or sutures)
- Thromboembolism
- Valve leakage
 - Paravalvular (perivalvular) leak
 - Transvalvular regurgitation
- Valve stenosis
- Valve thrombosis
- Valve frame distortion (from chest compression or trauma)

Valve malposition, instability, dislodgement, or migration/embolization are potential adverse events specific to a bioprosthetic valve with a reduced number of sutures like the EDWARDS INTUITY Elite Valve.

7.0 How Supplied

7.1 Packaging

The valve is provided sterile and nonpyrogenic, and is packaged in glutaraldehyde inside a sealed plastic jar.

Each valve is contained in a carton with a temperature indicator displayed through a window on the side panel. The temperature indicator is intended to identify products which have been exposed to transient temperature extremes. Please refer to the "Storage" section for product storage conditions. Upon receipt of the valve, immediately inspect the indicator and refer to the carton label to confirm a "Use" condition. If the "Use" condition is not apparent, do not use the valve and contact the local supplier or Edwards Lifesciences representative to make arrangements for return authorization and replacement. An EDWARDS INTUITY Elite valve system returned to Edwards Lifesciences must be shipped in the original packaging in which it was received with tamper evident band intact.

The delivery system is packaged in a double tray configuration. The delivery system is sterilized by E-beam.

An inflation device (model 96417) is provided for use with the delivery system. Refer to the inflation device package insert for Instructions for Use.

7.2 Handling and Preparation Instructions

Once the appropriate valve system size is chosen remove the delivery system tray package from the carton in the non-sterile field. Before opening, examine the package for evidence of damage. Open the delivery system outer tray using aseptic technique. Place the sterile inner tray containing the delivery system in the sterile field. (Refer to Section 8.3 for instructions on sizing of the valve.)

Warning: Fragments of the delivery system cannot be located by means of an external imaging device.

Warning: DO NOT USE the valve if the tamper evident seal on the jar is broken.

Warning: DO NOT USE the valve if the container is leaking, damaged, or the glutaraldehyde solution does not completely cover the valve.

Warning: Careful handling is required for all devices. If the valve and/or delivery system are dropped, damaged, or mishandled in any way, it must not be used.

Caution: Be sure to remove the product identification tag prior to implant of the valve.

7.3 Storage

The valve should be stored at 10-25 °C, (50-77 °F). Stock inspection and rotation at regular intervals are recommended to ensure that the valve and delivery systems are used before the expiration date stamped on the package label.

Products found to have been subjected to freezing or excessive heat later than 3 days following receipt will be considered to have resulted from environmental conditions within the control of the customer.

The delivery system should be stored in a cool, dry place.

Warning: DO NOT FREEZE OR EXPOSE THE VALVE TO EXTREME HEAT. Exposure to extreme temperatures will render the device unfit for use.

Caution: Always store the valve in a dry, contamination-free area. Any valve that is frozen, or is suspected of having been frozen, should not be used.

Warning: The valve must be carefully inspected before implanting for evidence of extreme temperature exposure or other damage.

8.0 Directions for Use

8.1 User Training

Physician training is required prior to use of the EDWARDS INTUITY Elite valve system.

8.2 Accessories

Arctic Sizers, model T133

The use of a sizing instrument facilitates selection of the correct size valve for implant, and a sizer is available for each size of the valve. The tray (model TRAY1133) is used to sterilize and store the accessories before and after use. Refer to the appropriate accessory Instructions for Use for details on cleaning, rinsing, disinfection, and sterilization of sizers.

Warning: Fragments of the sizers cannot be located by means of an external imaging device.

Caution: Examine sizers for signs of wear such as dullness, cracking, or crazing. Replace sizers if any deterioration is observed.

Caution: Only use the sizer recommended in this Instructions for Use.

Caution: The sizers are supplied nonsterile and must be cleaned and sterilized before use. Refer to the Sizer Instructions for Use for cleaning instructions.

8.3 Sizing

The final decision to use the EDWARDS INTUITY Elite valve system should be made after the native aortic valve is excised and the annulus is debrided, or decalcified. An assessment of the potential interaction between the EDWARDS INTUITY Elite valve system and surrounding cardiac structures – such as, the aortic annulus, anterior leaflet of the mitral valve, and coronary ostia – should be conducted to inform appropriate use of the device. Failure to consider these factors may lead to implant failure and clinical complications including, but not limited to, paravalvular leak, interference with mitral valve function, and severe conduction disturbances requiring permanent pacemaker implantation.

1. Exposure of the aortic valve via oblique aortotomy is recommended for ease of implant.
2. Surgically remove the diseased or damaged native valve leaflets and perform debridement as you would normally do for any conventional surgical valve. Debride calcium from the annulus, left ventricular outflow tract (LVOT), and the anterior mitral valve leaflet. The inside of the annulus and LVOT should be smooth to ensure proper seating of the prosthetic valve to achieve a good seal and minimize the risk of paravalvular leaks.

Warning: Avoid excessive debridement to the extent that it may result in annular injury or creates divots, compromise the integrity of the aortic annulus, and/or result in paravalvular leak.

Warning: Severely calcified LVOT that is not properly debrided may result in balloon rupture during inflation.

Caution: When choosing a valve, the size, age, and physical condition of the patient in relation to the size of the prosthesis must be taken into consideration to minimize the possibility of obtaining a suboptimal hemodynamic result. The selection of a valve must ultimately be made by the physician on an individual basis after carefully weighing all of the risks and benefits to the patient.

A combined intra- and supra-annular sizing technique is recommended for EDWARDS INTUITY Elite valve.

Caution: The practice of using only a supra-annular sizing technique for the EDWARDS INTUITY Elite valve is not recommended. Due to the intra-annular and sub-annular aspects of the EDWARDS INTUITY Elite valve, it is recommended to use both sizing techniques.

Intra-annular sizing

3. Insert the sizer barrel end through the aortotomy and place it into the aortic root and annulus.

Caution: If a transverse aortotomy is used and the sinotubular junction diameter is estimated to be equal or smaller than the annulus diameter, it is recommended to extend the aortotomy into the non-coronary sinus to facilitate sizer and implant insertion. If extension of the aortotomy is not possible, it is not recommended to use the product as parachuting the valve through a narrow sinotubular junction may result in increased difficulty of valve implant and/or aortic injury.

4. Size the valve choosing the largest diameter barrel end that is a comfortable fit in the annulus. Ensure that the lip of the barrel does not pass through the annulus (Figure 3). The lip of the barrel represents the sewing cuff of the valve, therefore it is intended to rest on the annulus and not go through it.

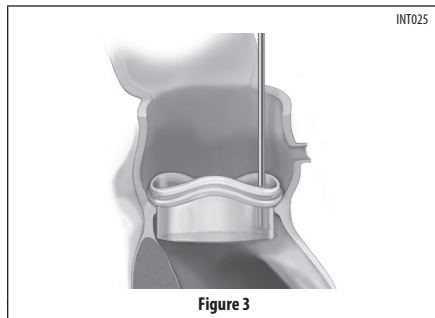

Figure 3

Warning: Do not implant a valve larger than the size indicated by the barrel end of the sizer as it may result in annular or aortic damage.

Warning: Do not select a valve size based on the sizer that will fit through the sinotubular junction as it may result in paravalvular leak due to the use of an undersized valve.

Supra-annular sizing

5. The replica end of the same sizer may be used to verify adequate fit and orientation of the supra-annular section of the valve in the aortic root. Adequate fit includes good seating on the aortic annulus and no interference of the commissure posts of the valve with the aortic wall at the sinotubular junction or with the coronary ostia (Figure 4). Use black orientation markers on the replica end to assess guiding suture placement in the annulus.

INT026

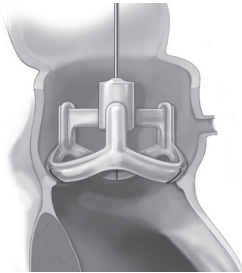

Figure 4

8.4 Preparation Instructions

Once the valve size has been determined and the decision to use the product is made, preparation of the delivery system and valve can be initiated. The balloon catheter and inflation device can be prepared concurrently while three equally spaced sutures required to fixate the valve are being placed through the aortic annulus, preferably at the nadir of each cusp. Implantation of the valve is described in Section 8.5.

1. Remove tamper evident band over delivery system and inflation device. Ensure that the selected delivery system size corresponds to the valve size.

Warning: Prior to use, verify that the size printed on the delivery system packaging corresponds with the appropriate size valve for which it is to be used.

2. After opening the inner tray remove the insertion/balloon introducer assembly (Figure 5).

INT027



Figure 5

3. The valve is provided in a jar with a screw-cap closure and tamper evident seal. Remove the seal and turn the lid counter clockwise to open the container. The contents of the jar (valve, holder, and sleeve) must be handled in an aseptic manner to prevent contamination. The outside of the jar is non-sterile.

Warning: Do not use if the packaging seals are broken or if the packaging has been damaged. Do not use if the valve is damaged.

Caution: It is strongly recommended that the valve not be opened until time of implant. This is necessary to reduce the risk of contamination, because it is established that glutaraldehyde alone is not a 100% effective sterilant against all possible contaminants. No attempt should be made to re-sterilize the valve.

4. With the valve in the jar, remove the insertion tool/balloon introducer assembly from the tray and insert the balloon introducer side through the valve leaflets until it engages the valve holder. Turn the insertion tool clockwise, threading the balloon introducer into the valve holder until it stops. Verify that the connection is tight (Figure 6).

INT063



Figure 6

Warning: Do not grasp the leaflet tissue of the valve with instruments or cause any damage to the valve. Even the most minor leaflet tissue perforation may enlarge in time to produce significant impairment of valve function.

5. Once secured, remove the sleeve and valve from the jar using the insertion tool. Confirm that the balloon introducer proximal end protrudes through the valve holder as shown. This is necessary to assure secure connection with the delivery system (Figure 7).

INT038

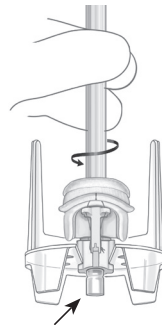

Figure 7

6. Remove the sleeve from the valve as shown in Figure 8.

INT092

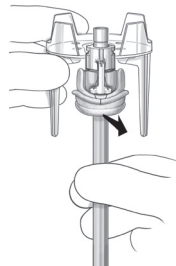

Figure 8

- A serial number tag is attached to the sewing ring of each valve by a suture. Carefully remove the serial number tag by cutting the suture and gently removing the tag.

Caution: This serial number should be checked against the number on the jar and implantation data card. If any difference is noted, the valve should be returned unused. This tag should not be detached from the valve until implant is imminent. Care should be exercised to avoid cutting or tearing the sewing ring cloth during removal.

Caution: Verify that all system connections are secure and fully engaged prior to use.

- Rinse the valve in sterile physiological saline for 1 minute. Fully submerge valve in rinse solution of approximately 500 ml sterile physiological saline. Slowly agitate the basin or the valve during the rinse cycle. Repeat this process once more using new saline solution for a minimum of 1 minute. Leave the valve submerged in the rinse basin until it is implanted.

Warning: The valve must be rinsed with sterile physiological saline prior to implant to reduce the glutaraldehyde concentration.

Warning: Do not add other solutions, drugs, or chemicals to the glutaraldehyde or rinse solutions as this may result in irreparable damage to the tissue. Damage may not be apparent during visual inspections.

Warning: Do not allow the valve to dry. It must be kept moist at all times. Maintain tissue moisture with sterile physiological saline irrigation on both sides of the leaflet tissue.

Warning: Prior to use, verify that the size printed on the balloon catheter corresponds with the appropriate size valve for which it is to be used.

Caution: Do not allow the leaflet tissue to contact the bottom or sides of the rinse basin.

Caution: Avoid contact of the valve or the rinse solution with towels, linens, or other sources of lint or particulate matter that may be transferred to the valve.

- Remove the delivery system from the tray.
- Remove the balloon cover from the balloon catheter. Ensure that the balloon does not advance (Figure 9a). In cases where the balloon does advance, pinch the locking clips and fully retract the balloon (Figure 9b).

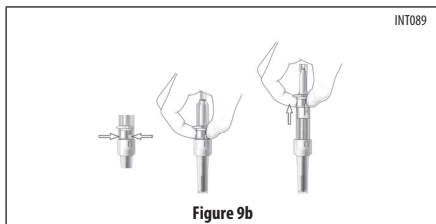
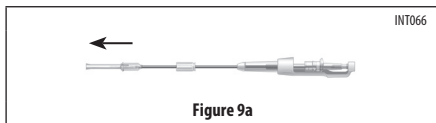

- Insert the balloon on the delivery system through the valve holder until the scalloped features of the adapter sit inside the matching scalloped features of the holder. A slight rotation may be necessary to align the scalloped features (Figure 10).

Caution: If there is any resistance engaging the adapter with the valve holder, stop and verify that the correct size delivery system is being used with the valve.

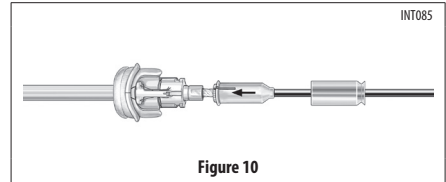

- Advance the locking sleeve over the adapter until it clicks into place (Figure 11).

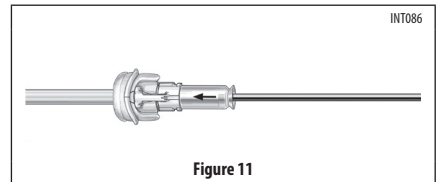

- Stabilize the valve by holding the malleable aluminum shaft and remove the insertion tool by pulling away from the valve and holder (Figure 12).

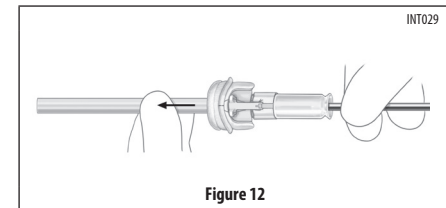

8.5 Implanting the Valve

- A simple suture technique is recommended to help confirm seating of the valve.
- Because pledgetted sutures are not recommended, avoid superficial suture placement through the native annulus, and place three equally spaced sutures through the native annulus, preferably at the nadir of each cusp.

Warning: The use of sutures with pledgets or monofilament sutures is not recommended. The use of pledgets may create leak channels resulting in paravalvular leaks. The use of monofilament sutures and resulting suture tails may damage the leaflets.

- Place each suture through the sewing ring in positions corresponding to the annular suture positions.

Caution: Extreme care must be exercised when placing sutures through the sewing ring margin to avoid laceration of the leaflet tissue.

- Parachute the valve into the annulus maintaining counter traction on the sutures (Figure 13).

Caution: Avoid bending the malleable handle greater than 90 degrees.

Caution: Avoid bending the malleable handle more than three times.

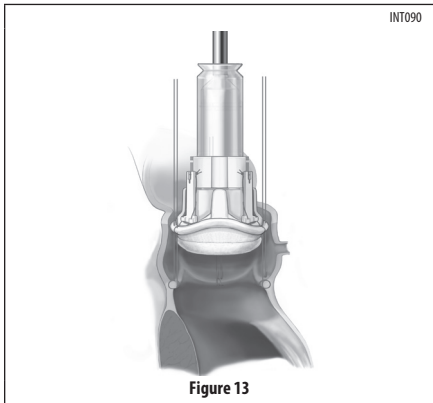

Caution: Do not advance the balloon catheter to the inflation position until the valve is properly positioned into the annulus to avoid potential injury to patient anatomy.

Caution: Suture tension must be maintained during parachuting to avoid frame and suture interference.

5. Once seated, hold the valve in place with the delivery system, and confirm the seating position of the valve onto the annulus. The commissure posts should correspond to the remnants of the native valve commissures so as not to obstruct the coronary ostia.

Caution: Maintaining proper seating of the valve is recommended to prevent valve displacement.

6. Secure the valve by snares compressed with hemostats over the sewing ring (Figure 14).

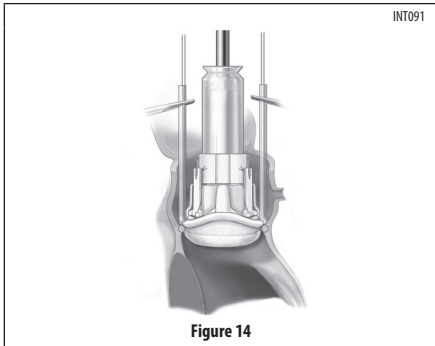

Caution: Ensure that the snares are placed directly on the sewing ring, not on the valve holder legs as this may result in loose sutures or difficulty in removing the holder/delivery system once the holder sutures are cut.

Caution: After securing the snares, appropriate valve seating should be confirmed by direct visual inspection. In particular, the valve must be firmly seated in the non-coronary sinus and no gaps should exist between the sewing cuff and native annulus. If adjustment is necessary, the snares may be loosened and the valve repositioned.

7. Verify that the coronary ostia are not obstructed, the commissure posts do not interfere with the aortic wall at the sinotubular junction and there is good apposition between the sewing ring and the annulus.
8. Fill the inflation device with sterile physiological saline and remove any air to a final volume of 25 cc (Figure 15).

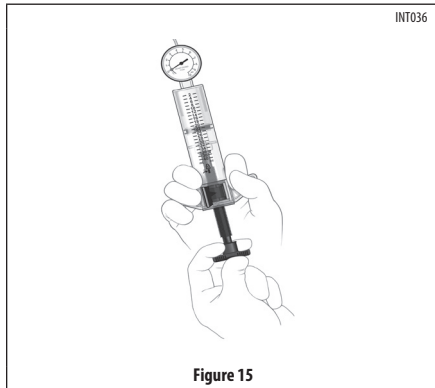

9. Advance the balloon catheter distally until the catheter snaps into place and an audible "click" is heard (Figure 16). Be sure to stabilize the handle while advancing the balloon catheter.

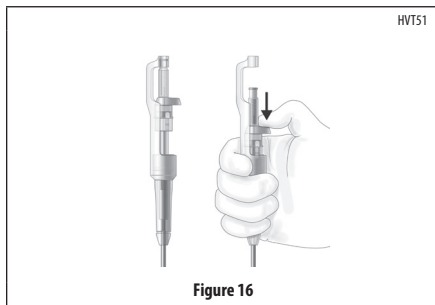

10. Attach the inflation device to the Luer inflation port on the balloon catheter (Figure 17).

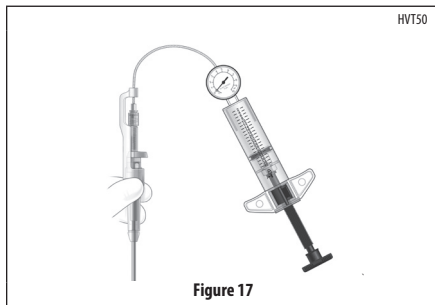

11. Ensure that the distal portion of the delivery system is perpendicular to the plane of the valve and apply gentle pressure in a distal direction to maintain proper valve seating during balloon inflation.

Caution: The delivery system must be held in position during balloon inflation to ensure that the valve remains seated in the annulus.

12. Inflate the balloon to the appropriate inflation pressure as shown in Table 2. This is achieved as follows:

- First unlock the inflation device
- Advance the plunger until resistance is felt (Figure 18)

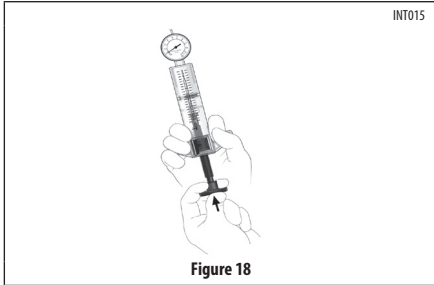

Figure 18

- Lock the inflation device
- Turn the knob for fine adjustments until the recommended nominal pressures are achieved and maintain nominal inflation pressure as on the delivery system for 10 seconds (Figure 19).

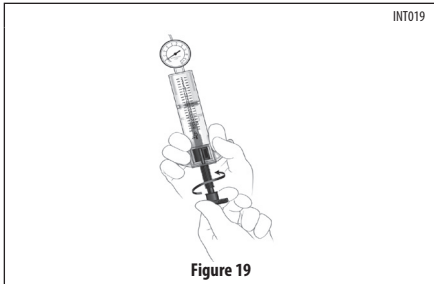

Figure 19

Caution: It is important to maintain inflation pressure, as listed in Table 2, by keeping an active hold on the knob; pressure must be maintained for 10 seconds to ensure proper frame expansion.

Table 2: Balloon Inflation Pressure

Valve Size	Inflation Pressure (ATM)	Rated Burst Pressure (ATM)
19 mm	4.5	7.0
21 mm	4.5	7.0
23 mm	4.5	7.0
25 mm	5.0	7.0
27 mm	5.0	7.0

Caution: Over-inflation may cause excessive frame expansion and may result in annular damage, conduction interference/arrhythmia, or sub-annular tissue damage.

Caution: Under-inflation may cause insufficient expansion of the frame and may result in paravalvular leak, thrombosis, and/or thromboembolism.

13. If the inflation pressure is not achieved, completely deflate the balloon by fully retracting the syringe plunger. Remove the valve and delivery system beginning with the removal of the snares and sutures. Use a new valve and delivery system.

Caution: Do not re-inflate the balloon. The balloon is designed for single use.

Caution: Do not retract the balloon catheter through the valve holder when removing the whole system to avoid possible valve displacement.

14. Once the inflation pressure is achieved and maintained for 10 seconds, deflate the balloon by unlocking the inflation device, fully retracting the plunger, and locking the plunger in the retracted position (Figure 20).

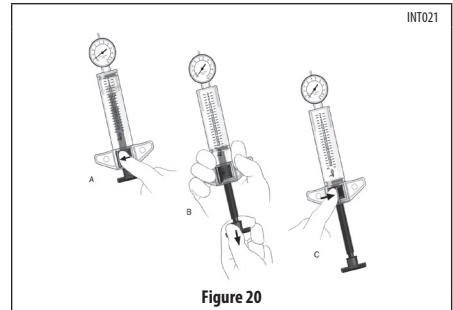

Figure 20

15. Cut each of the valve holder sutures utilizing a scalpel (Figure 21).

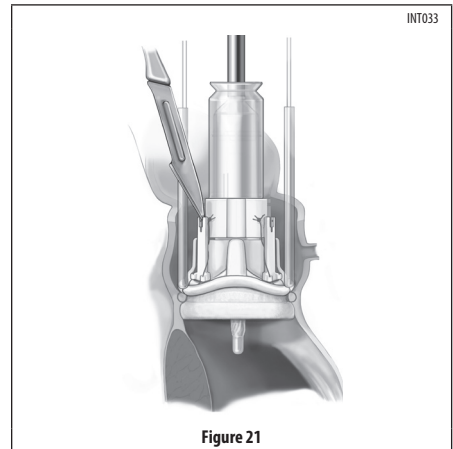

Figure 21

Caution: Avoid cutting or damaging the valve when cutting the sutures.

16. Remove the delivery system and valve holder as a unit.

Warning: Verify that the valve is properly seated in the annulus, there are no visible spaces between the valve and the annulus, the coronary ostia are not obstructed, and the commissure posts do not interfere with the aortic wall at the sinotubular junction to ensure proper blood flow.

- Remove one snare while maintaining valve seating position by applying downward pressure on the sewing ring and tie the suture. Repeat the process for the remaining two snares.

Warning: Use caution while removing the delivery system and tying the sutures to avoid valve displacement.

Warning: It is important to cut the sutures close to the knots and ensure that exposed suture tails will not come into contact with the valve leaflet tissue to prevent wear due to contact with the sutures (Ref. 8).

Warning: Do not pass catheters or transvenous pacing leads across the valve as this may cause tissue damage.

- Close Aortotomy per procedure.
- Minimal manipulation of the heart after valve implant is recommended to avoid valve displacement.
- Confirm valve function using transesophageal echocardiogram (TEE) before chest closure.

Caution: Failure to perform adequate TEE views may result in undetected paravalvular leaks.

8.6 Return of Explanted Valves

Edwards Lifesciences is interested in obtaining all unused or explanted EDWARDS INTUITY Elite valves for analysis. Please contact your local representative for return of recovered valves. The explanted or unused valve should be placed into a suitable histological fixative such as 10% formalin or 2% glutaraldehyde immediately after excision and returned to the company. Refrigeration is not necessary under these circumstances. Edwards will provide a written report summarizing the findings at the completion of the evaluation upon request.

8.7 Delivery System Disposal

The EDWARDS INTUITY Elite delivery system may be disposed of in the same manner that hospital waste and biohazardous materials are handled. There are no special or unusual risks related to the disposal of the device.

9.0 Clinical Study

9.1 Trial Design

The clinical study used for the FDA evaluation of the EDWARDS INTUITY Elite valve was the TRANSFORM trial. The TRANSFORM trial was an open-label, prospective, non-randomized, multicenter observational trial without concurrent or matched controls. The study was conducted at 29 centers in the United States. Following a preoperative assessment, subjects were seen for follow-up at 3 months postoperatively, one year postoperatively, and annually thereafter. A follow-up visit at 6 months postoperatively was required for subjects with device-related conduction disturbances or paravalvular leak greater than mild (2+) severity per the Echocardiography Core Laboratory for the trial.

The objective of the TRANSFORM trial was to evaluate the safety and effectiveness of the EDWARDS INTUITY Elite valve system in patients with aortic stenosis or mixed stenosis-insufficiency requiring replacement of the aortic valve.

9.2 Diagnosis and Main Criteria for Inclusion

The trial population consisted of adult subjects (18 years or older) diagnosed with aortic stenosis or stenosis-insufficiency requiring a planned replacement of the aortic valve. Concomitant coronary bypass surgery was permitted.

9.3 Preoperative Criteria for Exclusion

Trial candidates diagnosed with pure aortic insufficiency were excluded from participation. Candidates with prior valve replacement (any position) or prior valve surgery for which a prosthetic valve or annuloplasty ring remained *in situ* were also excluded. Multiple valve repairs or replacements were not permitted. Certain

planned non-cardiac surgeries were not permitted. Various clinical presentations and histories caused exclusion from the trial.

9.4 Intraoperative Criteria for Exclusion

Otherwise qualified candidates were excluded from study participation based on the following intraoperative exclusion criteria:

- anomalous coronary arteries
- annular deformation or extensive calcification of the annulus or aortic root which cannot be removed
- significant calcium on the anterior mitral leaflet
- pronounced septal calcification
- position of coronary ostia relative to the valve that would result in obstruction of blood flow

Finally, if a suitably sized device was not available for a particular annulus, the candidate was excluded from participation in the study.

9.5 Enrollment

The reporting period for the TRANSFORM trial was September 2012 through December 2015. At the time of the database lock, 889 patients were enrolled at the 29 investigational sites. Of the enrolled population, data were presented to the FDA for 839 patients successfully implanted with the EDWARDS INTUITY Elite valve in the aortic position. Among the 889 enrolled patients, there were 49 patients who experienced failure to implant.

The 839 implanted patients had a mean follow-up of 1.1 ± 0.7 years, a range of follow-up of 0 to 2.9 years, and a total cumulative follow-up of 912.2 patient-years. There were 844.5 late patient-years of follow-up for the implanted patients.

9.6 Basic Demographics

Table 3: Basic Demographics

Age at Implant	N: Mean \pm SD (Min - Max)
Age (years)	839: 73.5 \pm 8.3 (34 – 95)
Sex	% (n / N)
Female	35.5% (298 / 839)
Male	64.5% (541 / 839)
NYHA Classification ¹	% (n/N)
Class I	15.6% (130 / 836)
Class II	52.2% (436 / 836)
Class III	30.5% (255 / 836)
Class IV	1.8% (15 / 836)
Risk Scores	N: Mean \pm SD (Min - Max)
STS risk of mortality (%) ²	733: 2.5 \pm 1.8 (0.4 – 14.6)
EuroSCORE II (%)	839: 3.3 \pm 3.4 (0.5 – 31.6)

¹ Preoperative NYHA class unavailable for 3 subjects.

² STS scores only calculated for subjects undergoing isolated AVR or AVR+CABG.

9.7 Follow-up Compliance

Table 4: Follow-up Compliance

Visit Interval	Eligible Subjects	Follow-up Compliance % ¹ (n)	Censored ² (N)
Preoperative	839	100.0% (839)	0
Discharge	831	99.9% (830)	8
3 Month	778	97.0% (755)	61
1 Year	573	96.3% (552)	266
2 Year	215	94.4% (203)	624

¹ % compliance = $100 * n / N$

² Censoring due to pending visit, explant, study exit, death or lost to follow-up.

9.8 Safety Results

Table 5: Observed Adverse Event Rates

Adverse Event or Outcome	Early ¹ (N=839) n, m (%)	Late ² (LPY ³ = 844.5) n, m, (%/pt-yr)	Freedom-from Event at 1 Year (SE) ⁴
All mortality	7, 7 (0.8)	25, 25 (3.0)	0.964 (0.007)
Valve-related mortality	4, 4 (0.5)	9, 9 (1.1)	0.985 (0.005)
Reoperation	2, 2 (0.2)	7, 8 (0.9)	0.993 (0.003)
Explant	1, 1 (0.1)	4, 4 (0.5)	0.996 (0.002)
Thromboembolism	29, 29 (3.5)	22, 22 (2.6)	0.939 (0.009)
Stroke	22, 22 (2.6)	11, 11 (1.3)	0.961 (0.007)
Valve thrombosis	0, 0 (0.0)	0, 0 (0.0)	1.000 (0.000)
Endocarditis	0, 0 (0.0)	0, 0 (0.0)	1.000 (0.000)
All bleeding	13, 13 (1.5)	37, 43 (5.1)	0.941 (0.009)
Major bleeding	11, 11 (1.3)	19, 21 (2.5)	0.962 (0.007)
All paravalvular leak	9, 9 (1.1)	15, 15 (1.8)	0.977 (0.005)
Major PVL	2, 2 (0.2)	7, 7 (0.8)	0.993 (0.003)
Hemolysis	0, 0 (0.0)	3, 3 (0.4)	0.997 (0.002)
Non-Structural Valve Dysfunction (non-PVL) ⁵	6, 6 (0.7)	3, 3 (0.4)	0.989 (0.004)
Valve migration	0, 0 (0.0)	0, 0 (0.0)	1.000 (0.000)
Valve malposition	2, 2 (0.2)	1, 1 (0.1)	0.996 (0.002)
Valve instability	2, 2 (0.2)	1, 1 (0.1)	0.996 (0.002)
Valve dislodgement	0, 0 (0.0)	0, 0 (0.0)	1.000 (0.000)
Valve stenosis ⁶	4, 4 (0.5)	2, 2 (0.2)	0.992 (0.003)
Structural Valve Deterioration	0, 0 (0.0)	0, 0 (0.0)	1.000 (0.000)
Site-reported permanent pacemaker implant ⁷ (n=785, LPY=786.7)	111, 111 (14.1)	15, 15 (1.9)	0.845 (0.013)

¹ For 'Early Events' (events occurring thru post-implant day 30): For 'Early' m is the number of events; n is the number of subjects experiencing an event; % = n/N.

² For 'Late Events' (events occurring after post-implant day 30): m is the number of events; n is the number of subjects experiencing an event; and % = m/LPY.

³ LPY: Late patient-years; LPY are calculated from post-implant day 31 until the last patient contact

⁴ Based on Kaplan-Meier analysis of time to first occurrence (early or late). Standard Error (SE) based on Greenwood's formula.

⁵ Echo Core Lab findings of mild rocking or dehiscence count as both valve malposition and valve instability, but only count once in the overall counts of NSVD (non-PVL).

⁶ Valve stenosis includes all site-reported events independent of clinical sequelae and without evidence of calcification. For the 6 cases noted, all patients were asymptomatic at the time of the data lock.

⁷ Includes permanent pacemaker implant required for treatment of cardiac arrhythmia(s) or conduction disturbance(s) as reported by the investigational site. If multiple PPI for the same subject were reported, the event with the earliest onset date is summarized. Excludes patients with pre-existing PPIs.

Table 6 presents the results of the TRANSFORM trial compared to the OPC as described in Table R.1 in EN ISO 5840:2009, Annex R.1.

Table 6: Linearized Late Rates Compared to the OPC

Adverse Event	Late ¹ (LPY ² = 844.5) n, m, (%/pt-yr)	95% UCL ³	2X OPC ⁴
Thromboembolism	22, 22 (2.6)	3.7	5.0
Valve thrombosis	0, 0 (0.0)	0.2	0.4

Adverse Event	Late ¹ (LPY ² = 844.5) n, m, (%/pt-yr)	95% UCL ³	2X OPC ⁴
All bleeding	37, 43 (5.1)	6.5	2.8
Major bleeding	19, 21 (2.5)	3.5	1.8
All paravalvular leak	15, 15 (1.8)	2.7	2.4
Major PVL	7, 7 (0.8)	1.5	1.2
Endocarditis	0, 0 (0.0)	0.2	2.4

¹ For 'Late Events' (events occurring after post-implant day 30): m is the number of events; n is the number of subjects experiencing an event; and % = m/LPY.

² LPY: Late patient-years; LPY are calculated from post-implant day 31 until the last patient contact.

³ UCL is the one-sided 95% Upper Confidence Limit for the linearized rate.

⁴ FDA Objective Performance Criteria for tissue valves as described in Table R.1 of EN ISO 5840:2009, Annex R.1.

Table 7 presents the number of new or worsened cardiac conduction disturbances or arrhythmias determined to be device-related by the investigational site.

Table 7: Site-Reported Device-Related New or Worsened Cardiac Conduction Disturbances

Device-Related ¹ Adverse Event	Postoperative Onset Day			
	Early (Day 0) n ²	Early (1-30 Days) n ²	Late (>30 Days) n ²	All Events n ²
Requiring Permanent Pacemaker Implant (PPI)				
AV block I	0	1	0	1
AV block III	0	6	1	7
Tachy-bradycardia	0	1	0	1
Total requiring PPI ³	0	8	1	9
Not requiring Permanent Pacemaker Implant (PPI)				
AV block I	1	5	3	9
AV block III	1	0	0	1
Atrial flutter	0	1	0	1
LBBB	11	9	1	21
RBBB	0	1	1	2
Other arrhythmia	2	4	2	8
Paroxysmal atrial fibrillation	0	2	0	2
Total not requiring PPI	14	20	7	40
Total	14	27	8	47

¹ Device-related includes those events considered related to the trial valve or trial delivery system. Eight (8) events were reported as both device- and procedure-related.

² n is the number of subjects experiencing an event; if multiple PPI for the same subject were reported, the event with the earliest onset date is summarized.

³ Total does not include 38 PPI considered unrelated to the device or procedure and 2 events where the relationship to the device or procedure could not be determined.

Table 8 presents the number of new or worsened cardiac conduction disturbances or arrhythmias determined to be procedure-related by the investigational site which required permanent pacemaker implant.

Table 8: Site-Reported Procedure-Related New or Worsened Cardiac Conduction Disturbances Requiring Permanent Pacemaker Implant

Procedure-Related ¹ Adverse Event	Postoperative Onset Day			
	Early (Day 0) n ²	Early (1-30 Days) n ²	Late (>30 Days) n ²	All Events n ²
AV block I	0	4	0	4
AV block II ³	0	4	2	6
AV block III	0	54	1	55
Bradycardia	0	2	1	3
LBBB	0	4	1	5
Other arrhythmia	0	6	1	7
Paroxysmal atrial fibrillation	0	2	0	2
Tachy-bradycardia	0	3	0	3
Total requiring PPI^{3,4}	0	79	6	85

¹ Procedure-related includes those events considered related to the cardiac surgery or the trial procedure. Eight (8) events were reported as both device- and procedure-related.

² n is the number of subjects experiencing an event; if multiple PPI for the same subject were reported, the event with the earliest onset date is summarized.

³ The date of onset for one AV block II event was unknown; this event is included in the 'All events' column.

⁴ Total does not include 38 PPI considered unrelated to the device or procedure and 2 events where the relationship to the device or procedure could not be determined.

9.9 Effectiveness Results

Table 9: Improvement in NYHA Classification

NYHA Class	Baseline NYHA % (n / N ¹)	1-Year NYHA % (n / N ¹)
Class I	14.5% (79 / 546)	77.1% (421 / 546)
Class II	51.1% (279 / 546)	19.6% (107 / 546)
Class III	32.6% (178 / 546)	2.7% (15 / 546)
Class IV	1.8% (10 / 546)	0.5% (3 / 546)

¹ n is the number of subjects who have both preoperative and 1 year NYHA data

Table 10: Hemodynamic parameters at 1-Year

Parameter	19 mm Mean±SD (n ¹)	21 mm Mean±SD (n ¹)	23 mm Mean±SD (n ¹)	25 mm Mean±SD (n ¹)	27 mm Mean±SD (n ¹)
EOA (cm ²)	1.1 ± 0.1 (36)	1.3 ± 0.1 (113)	1.7 ± 0.2 (157)	1.9 ± 0.2 (127)	2.2 ± 0.2 (58)
Mean Gradient (mmHg)	13.9 ± 3.9 (36)	11.6 ± 3.6 (115)	10.4 ± 3.5 (165)	9.1 ± 3.2 (132)	8.3 ± 3.7 (61)

¹ n represents the number of subjects with evaluable data.

Table 11: Total aortic regurgitation by follow-up visit

Visit Size	None % (n/N ¹)	Trace % (n/N ¹)	Mild % (n/N ¹)	Moderate % (n/N ¹)	Severe % (n/N ¹)
1 YEAR					
All subjects	46.8% (244/521)	44.3% (231/521)	7.3% (38/521)	1.2% (6/521)	0.4% (2/521)
19 mm	21.1% (8/38)	65.8% (25/38)	13.2% (5/38)	0.0% (0/38)	0.0% (0/38)

Visit Size	None % (n/N ¹)	Trace % (n/N ¹)	Mild % (n/N ¹)	Moderate % (n/N ¹)	Severe % (n/N ¹)
1 YEAR					
21 mm	45.8% (54/118)	50.8% (60/118)	2.5% (3/118)	0.8% (1/118)	0.0% (0/118)
23 mm	44.6% (74/166)	44.6% (74/166)	7.8% (13/166)	3.0% (5/166)	0.0% (0/166)
25 mm	55.5% (76/137)	33.6% (46/137)	10.2% (14/137)	0.0% (0/137)	0.7% (1/137)
27 mm	51.6% (32/62)	41.9% (26/62)	4.8% (3/62)	0.0% (0/62)	1.6% (1/62)
2 YEAR					
All subjects	44.8% (74/165)	45.5% (75/165)	9.7% (16/165)	0.0% (0/165)	0.0% (0/165)
19 mm	18.8% (3/16)	62.5% (10/16)	18.8% (3/16)	0.0% (0/16)	0.0% (0/16)
21 mm	40.9% (18/44)	56.8% (25/44)	2.3% (1/44)	0.0% (0/44)	0.0% (0/44)
23 mm	47.8% (22/46)	43.5% (20/46)	8.7% (4/46)	0.0% (0/46)	0.0% (0/46)
25 mm	51.2% (22/43)	30.2% (13/43)	18.6% (8/43)	0.0% (0/43)	0.0% (0/43)
27 mm	56.3% (9/16)	43.8% (7/16)	0.0% (0/16)	0.0% (0/16)	0.0% (0/16)

¹ N represents the number of subjects with evaluable data.

Table 12: Paravalvular leak by follow-up visit

Visit Size	None % (n/N ¹)	Trace % (n/N ¹)	Mild % (n/N ¹)	Moderate % (n/N ¹)	Severe % (n/N ¹)
1 YEAR					
All subjects	75.5% (392/519)	16.0% (83/519)	6.9% (36/519)	1.2% (6/519)	0.4% (2/519)
19 mm	63.2% (24/38)	26.3% (10/38)	10.5% (4/38)	0.0% (0/38)	0.0% (0/38)
21 mm	83.8% (98/117)	12.8% (15/117)	2.6% (3/117)	0.9% (1/117)	0.0% (0/117)
23 mm	70.9% (117/165)	18.2% (30/165)	7.9% (13/165)	3.0% (5/165)	0.0% (0/165)
25 mm	73.7% (101/137)	15.3% (21/137)	10.2% (14/137)	0.0% (0/137)	0.7% (1/137)
27 mm	83.9% (52/62)	11.3% (7/62)	3.2% (2/62)	0.0% (0/62)	1.6% (1/62)
2 YEAR					
All subjects	75.8% (125/165)	14.5% (24/165)	9.7% (16/165)	0.0% (0/165)	0.0% (0/165)
19 mm	56.3% (9/16)	25.0% (4/16)	18.8% (3/16)	0.0% (0/16)	0.0% (0/16)
21 mm	81.8% (36/44)	15.9% (7/44)	2.3% (1/44)	0.0% (0/44)	0.0% (0/44)
23 mm	78.3% (36/46)	13.0% (6/46)	8.7% (4/46)	0.0% (0/46)	0.0% (0/46)
25 mm	69.8% (30/43)	11.6% (5/43)	18.6% (8/43)	0.0% (0/43)	0.0% (0/43)
27 mm	87.5% (14/16)	12.5% (2/16)	0.0% (0/16)	0.0% (0/16)	0.0% (0/16)

¹ N represents the number of subjects with evaluable data.

Table 13 presents the aortic cross-clamp times for the ENROLLED cohort in the TRANSFORM trial as compared to surgical times entered into the STS Adult Cardiac Surgery Database between July 2011 and December 2012 for comparable procedures.

Table 13: Aortic cross-clamp times

Surgical Group	ENROLLED (n: mean ± SD)	STS Database (n: mean ± SD)	p-value
Isolated AVR, Full Sternotomy	221: 49.3 ± 26.9	27205: 76.35 ± 28.12	<0.001
Isolated AVR, MIS	327: 63.1 ± 25.4	6815: 82.98 ± 29.30	<0.001
AVR + CABG 1 graft	89: 66.6 ± 25.7	8778: 94.88 ± 30.96	<0.001
AVR + CABG 2 grafts	76: 89.2 ± 27.3	6720: 111.60 ± 34.19	<0.001
AVR + CABG 3 grafts	38: 113.1 ± 38.2	5247: 127.73 ± 37.93	0.071
AVR + CABG 4+ grafts	7: 148.9 ± 40.0	2573: 141.99 ± 43.57	1.0

Two-sample t-tests are used to compare EDWARDS INTUITY to the STS database. p-values are adjusted using Holm's method for 14 comparisons (six subgroups for both clamp and pump time, SF-12 Mental and Physical Health).

Data from the STS Adult Cardiac Surgery Database is derived from the period of July 2011 - December 2012.

Table 14 presents the cardiopulmonary bypass (pump) times for the ENROLLED cohort in the TRANSFORM trial as compared to surgical times entered into the STS Adult Cardiac Surgery Database between July 2011 and December 2012 for comparable procedures.

Table 14: Cardiopulmonary bypass (pump) times

Surgical Group	ENROLLED (n: mean ± SD)	STS Database (n: mean ± SD)	p-value
Isolated AVR, Full Sternotomy	222: 69.2 ± 34.7	27275: 104.23 ± 41.01	<0.001
Isolated AVR, MIS	327: 84.6 ± 33.5	6228: 111.44 ± 41.65	<0.001
AVR + CABG 1 graft	89: 87.1 ± 34.2	8792: 125.95 ± 43.95	<0.001
AVR + CABG 2 grafts	76: 113.3 ± 38.4	6738: 144.95 ± 45.12	<0.001
AVR + CABG 3 grafts	38: 140.6 ± 44.0	5255: 163.60 ± 49.76	0.011
AVR + CABG 4+ grafts	7: 171.0 ± 44.4	2575: 180.49 ± 53.41	1.0

Two-sample t-tests are used to compare EDWARDS INTUITY to the STS database. p-values are adjusted using Holm's method for 14 comparisons (six subgroups for both clamp and pump time, SF-12 Mental and Physical Health).

Data from the STS Adult Cardiac Surgery Database is derived from the period of July 2011 - December 2012.

10.0 Safety in the Magnetic Resonance (MR) Environment



Non-clinical testing has demonstrated that the EDWARDS INTUITY Elite valve, model 8300AB is MR Conditional. A patient with the valve can be scanned safely under the following conditions:

- Static magnetic field of 1.5 tesla and 3.0 tesla

- Maximum spatial magnetic gradient field of 2670 Gauss/cm or less
- Maximum MR system-reported, whole body averaged SAR of 2.0 W/kg in the normal operating mode for 15 minutes of MR scanning per sequence

Under the scan conditions defined above, the EDWARDS INTUITY Elite valve, model 8300AB is expected to produce a maximum temperature rise of less than 2 °C after 15 minutes of continuous scanning.

In non-clinical testing, the image artifact caused by the device extends up to 40 mm from the implant when imaged with spin echo and gradient echo pulse sequences in a 3.0T MRI system. The lumen is partially to fully occluded under these conditions.

11.0 Patient Information

11.1 Registration Information

An Implantation Data Card is included in each valve device package for patient registration. After implant, please complete all requested information. The EDWARDS INTUITY Elite valve serial number is listed on the valve packaging and on the identification tag attached to the valve, and is pre-printed on the Implantation Data Card. Return the pre-addressed portion of the card to our Implant Patient Registry. The remaining portions of the card are provided for hospital and surgeon records. Upon receipt by the Edwards Implant Patient Registry, a wallet-sized identification card will be produced for the patient. This card allows patients to inform healthcare providers what type of implant they have when they seek care. When a valve is discarded or a previous Edwards Lifesciences device is replaced, report this information to the Edwards Implant Patient Registry.

This product is manufactured and distributed under at least one or more of the following U.S. Patents: US-Patent Nos. 5,928,281; 5,961,549; 6,102,944; 6,214,054; 6,245,105; 6,413,275; 6,547,827; 6,585,766; 6,837,902; 6,945,997; 7,214,344; 8,366,769; 8,518,108; 8,632,608; 8,641,757; 8,696,742; 8,911,493; and 9,125,741; and corresponding foreign patents. Likewise, additional patents pending.

12.0 References

1. Carpentier, A., et al. Biological Factors Affecting Long-Term Results of Valvular Heterografts. *J. Thorac. Cardiovasc. Surg.* 1969, 58:467-483.
2. Carpentier, A., et al. Six Year Follow-up of Glutaraldehyde Preserved Heterografts. *J. Thorac. Cardiovasc. Surg.* 1974, 68:771-782.
3. Jamieson, W.R.E., et al. Carpentier-Edwards Standard Porcine Bioprosthesis: Primary Tissue Failure (Structural Valve Deterioration) by Age Groups. *Ann. Thorac. Surg.* 1988, 46:155-162.
4. Odell, J.A. Calcification of Porcine Bioprostheses in Children. In Cohn, L. and V. Gallucci (eds): *Cardiac Bioprostheses*. Yorke Medical Books. New York, 1982, pp 231-237.
5. Reul, G.J., et al. Valve Failure with the Ionescu-Shiley Bovine Pericardial Bioprosthesis: Analysis of 2680 Patients. *J. Vasc. Surg.* 1985, 2(1):192-204.
6. Sanders, S.P., et al. Use of Hancock Porcine Xenografts in Children and Adolescents. *Am. J. Cardiol.* 1980, 46(3):429-438.
7. Silver, M.M., et al. Calcification in Porcine Xenograft Valves in Children. *Am. J. Cardiol.* 1980, 45:685-689.
8. Carpentier, A., et al. Continuing Improvements in Valvular Bioprostheses. *J. Thorac. Cardiovasc. Surg.* 1982, 83(1):27-42.



Edwards Lifesciences LLC
One Edwards Way
Irvine, CA 92614 USA
Made in USA

Telephone 949.250.2500
800.424.3278
FAX 949.250.2525

08/2016
159158003 LL
©Copyright 2016, Edwards Lifesciences LLC
All rights reserved.



**Vendor: Do Not Print This Page.
For Internal Edwards Lifesciences Use Only.**

<h2 style="margin: 0;">Edwards Lifesciences</h2> <p style="margin: 0; font-size: small;">Irvine, CA 92614</p>						
Title: IFU, 8300AB/DB, US						
Label Item Revision: 159158003/A	Graphic Artist: NANCY SMITH	Date: 8/13/16	Page 13 of 13			
Visual Representation: DOC-0032793	First Proofer: NAM HOANG	Date: 8/13/16	Full Proof <input checked="" type="checkbox"/>	Proofed Against Redline <input checked="" type="checkbox"/>	Docuproof <input type="checkbox"/>	
Drawing / Specification: DOC-0006152	Second Proofer: MARIA CARDENAS	Date: 8/13/16	Full Proof <input type="checkbox"/>	Proofed Against Redline <input type="checkbox"/>	Docuproof <input checked="" type="checkbox"/>	

NOTE

1. ALL ART PRINTS 100% BLACK UNLESS OTHERWISE NOTED.

**INK
BLACK**