

EE 43 PROJECT 1: AN AUDIO AMPLIFIER

Part 2: Audio Amplifier

Lab Guide

In this lab we're going to extend what you did last time. We're going to use your AC to DC converter to power an audio amplifier. Important: we're going to be playing around with the audio amplifier in this lab, and it's nice to use a real audio source to play with. Bring in an audio player from home. For example, bring a discman, walkman, iPod, MP3 player, etc.

1 Tips For Lab

Before you begin, one simple bit of advise: build clean, neat circuits. Use the shortest wire possible, use the power rails on your board instead of stringing 5V and ground everywhere, and be methodical when you wire so that you (and your GSI) can make sense of it. If you build your circuit in a strange, non-intuitive way, your GSI will not be able to help you debug it. Figure 1 shows an example of a well-built circuit.

2 Power Supply

You should have saved your AC to DC converter circuit from last week. We'll use that circuit to power the audio amplifier we build in this lab.

Modify your circuit to look like Figure 2. Notice that the load resistor has been removed, and an LED has been added. This LED is simply an indicator that will tell you when the board is powered up. Since we're going to be using delicate ICs in this lab, you should only touch them when the power is turned off. This LED will serve as your reminder.

Important Note: Figure 2 shows the AC to DC converter being connected to both 5V and ground. These are reference only. Do not actually connect a lab power supply to this. The circuit is providing power to the 5V node, and the ground shown here is intended to be the reference ground for all circuitry on your breadboard. In short, anytime you see a ground symbol connected to a node it simply means that those nodes are to be shorted together and used as the reference ground. Anytime you see a 5V symbol connected to a node it means that those nodes are to be shorted together.

3 Amplifier System Block Diagram

A block diagram for the amplifier system is shown in Figure 3. It consists of a simple tone control circuit followed by a power amplifier.

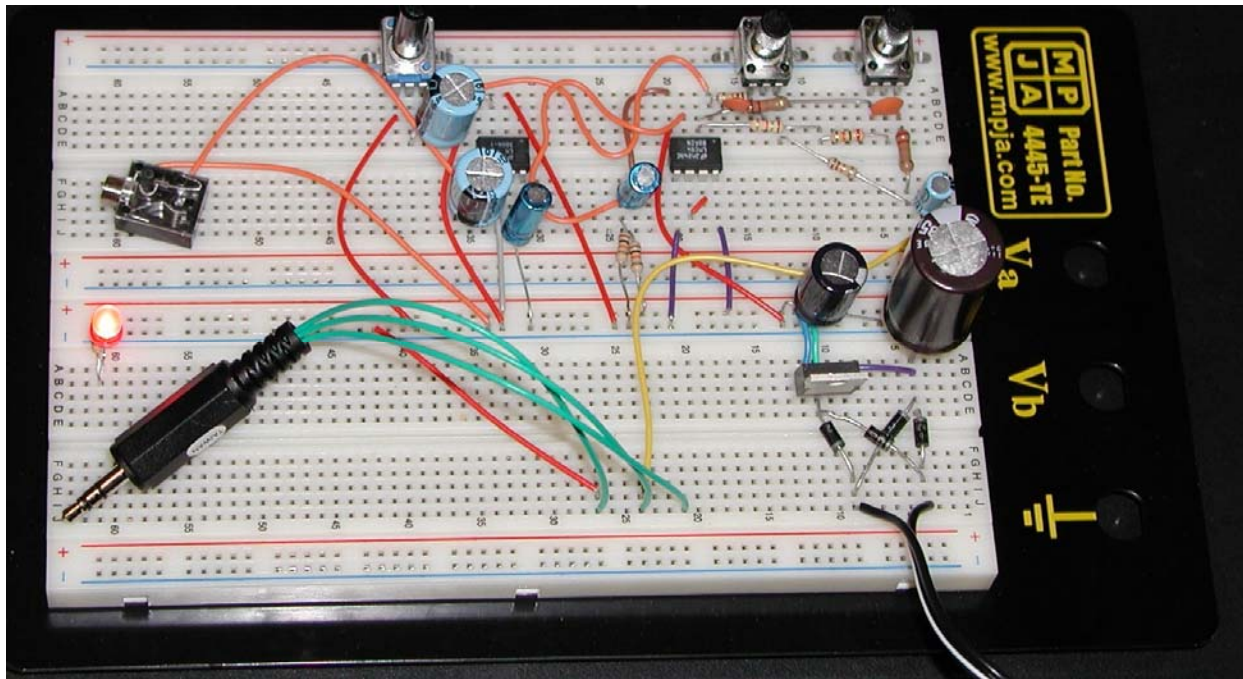

Figure 1: A well-built amplifier circuit.

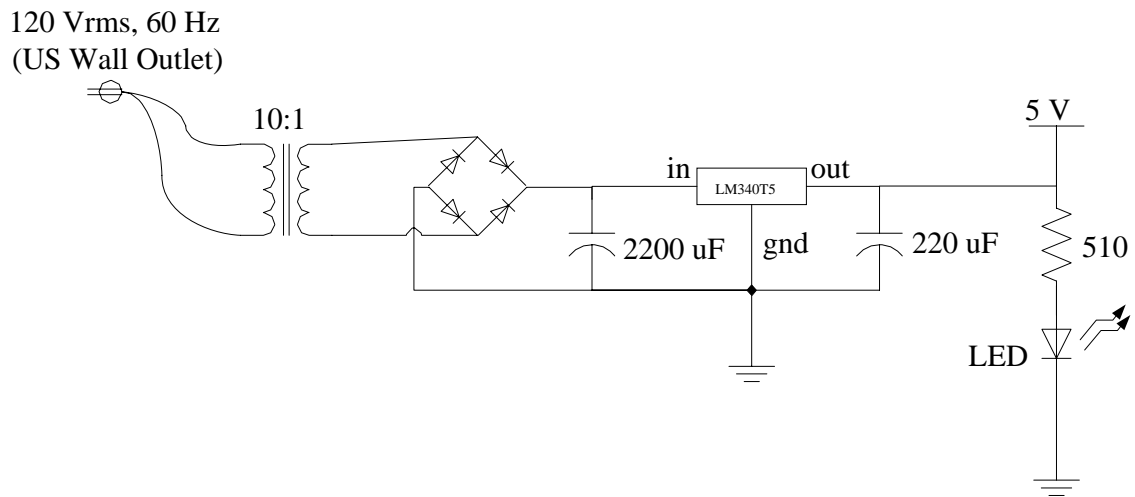

Figure 2: AC to DC converter from part 1.

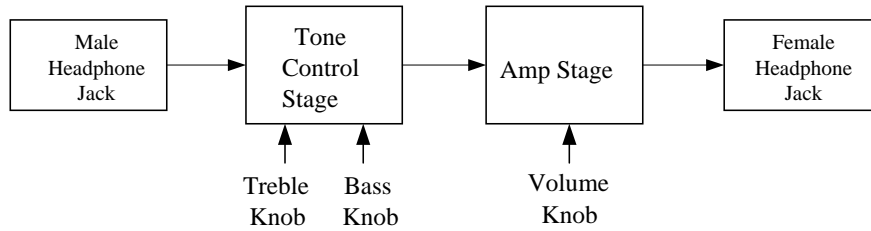

Figure 3: Amplifier block diagram.

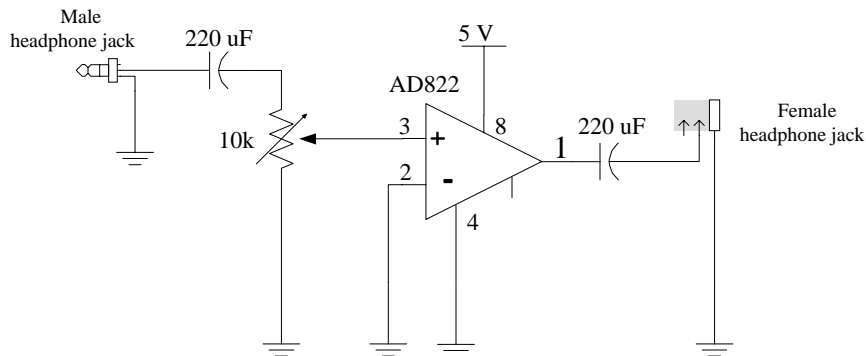

Figure 4: Audio power amplifier circuit.

4 Audio Amp Circuit the circuit used to implement Figure 3 is rather complicated, and we'll build it up in two pieces. The first piece to build is the audio amplifier.

The audio amplifier schematic is shown in Figure 4. You need to assemble this circuit on your breadboard. There are a few important notes to go with this assembly:

Male Headphone Jack: You have one male headphone jack in your lab kit. In order to plug this into your breadboard, you need to solder (pronounced saw-der) some wires onto it. Soldering is a process where you touch two wires together and then use a hot iron to melt metal (solder) over the junction. See Figure 6 for an example of a soldered jack. This was build using this simple procedure:

1. Select three long wires from your lab kit.
2. For each wire, use your wire strippers to cut one stripped end to about 3/16". Leave the other end as it is.
3. Using needle-nosed pliers, bend the 3/16" end to make a hook. Repeat for all 3 wires.
4. Find your male headphone jack. The black plastic bit unscrews from the metal. Take it apart to find three metal tabs. The biggest tab is ground, and the other two are the left and right channels.
5. Carefully hook a wire into each of the three tabs. Make a note of which wire is hooked into the ground tab. This will be the wire you connect to ground in the amp circuit.

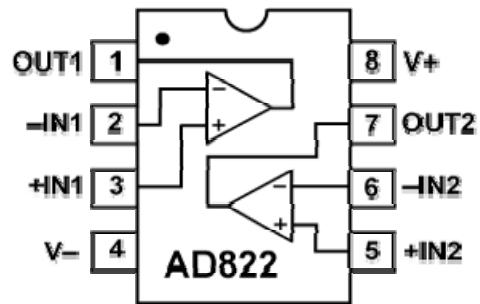

Figure 5: Pinout of the AD822 power amplifier chip.

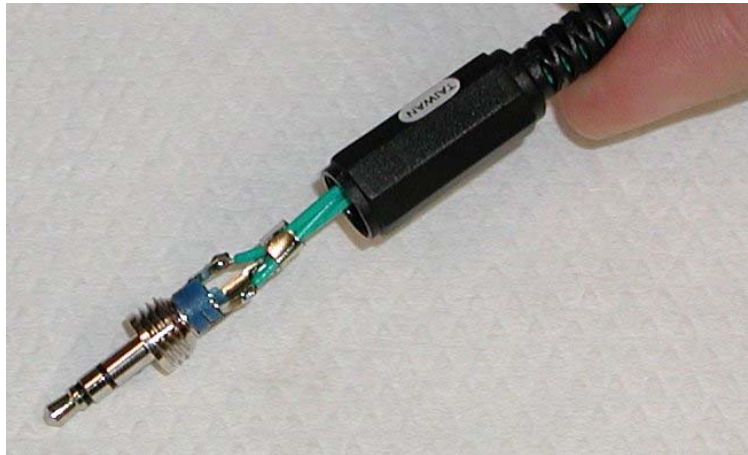

Figure 6: A soldered male headphone jack.

6. Use a soldering iron to melt a very small bit of each hook. See Figure 6 for an example of the result.

AD822 Chip: Pins 6 and 7 of the AD822 should be connected together and pin 5 should be grounded. This is intentional to prevent the unused op-amp on the chip from oscillating and introducing noise into the circuit. The same will need to be done to the OP284 chip (shown in Figure 7). For your convenience, the pin out of the AD822 is shown in Figure 5.

Female Headphone Jack: There is no need to solder wires onto the female headphone jack. It will fit into the breadboard. Note that, like the male headphone jack, only one of the channels is used here. Connect the audio output to either the left or the right channel (your pick), and leave the other channel open.

Once your amp circuit is built, check it over very carefully. We're going to be plugging into another audio device (ex: Discman), and we don't want to ruin the other device just because of a wiring error. When you are satisfied with your circuit, plug in your audio device and your headphones and power it up. Play with the volume knob. How does it sound?

5 Tone Control Circuit

We now will build the tone control part of this audio system. The tone control will allow you to adjust the bass and treble contents of your audio signal. Modify your amp circuit to look like Figure 7. This circuit uses what's called a Baxandall tone control circuit ¹.

This circuit has a lot of discrete components. Build it carefully and double check all your connections. Note also that this circuit uses an OP284 op-amp. For your convenience, the pin out of the OP284 is shown in Figure 8.

5.1 Understanding the Tone Control Circuit

The tone control circuit is rather complicated. Before you build anything, it is always a good idea to understand how it works. This gives you an intuition for what to look at if something goes wrong and you need to debug, and it also makes the whole process much more fun. For a description of what's happening in the tone control circuit, see Figure 9 and read below.

The positive input to the OP284 is simply half of the power supply due to the 10k resistors. The 10 F capacitor seen at the positive input merely helps keep the node stable (free of AC variations). The purpose of the 1F capacitor is to block any DC component of the input audio signal. DC voltages don't contain any information about sound, therefore it unnecessary. The rest of the passive components are involved in the feedback path. The key to understanding the bass and treble gains lies in the potentiometers.

If our input signal is very low in frequency, the top potentiometer controls the gain. Because the 22 nF capacitor appears as an open, our input signal simply divides inside the potentiometer. Note that for low frequencies, the 560 pF capacitor is effectively and open and doesn't feed signal through from the bottom potentiometer.

When the input signal is high in frequency, no voltage develops across the top potentiometer because the 22 nF capacitor appears as a short. However, the bottom potentiometer divides the input signal and feeds it through the 560 pF capacitor (which now appears as a short) to the input. So for high frequencies, the gain is controlled by the lower potentiometer.

¹ See <http://sound.westhost.com/dwopa2.htm>

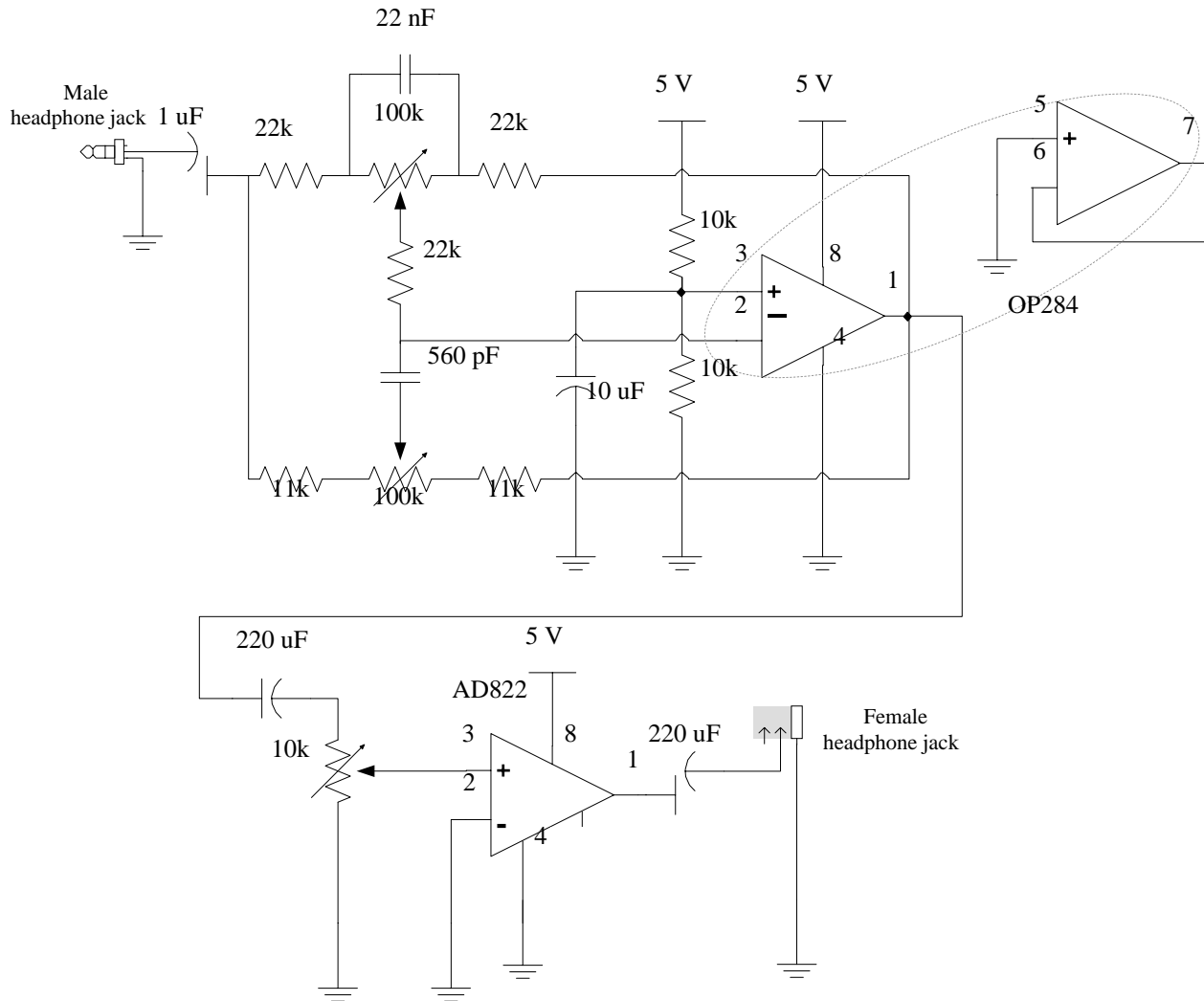

Figure 7: The complete audio amplifier (scary?).

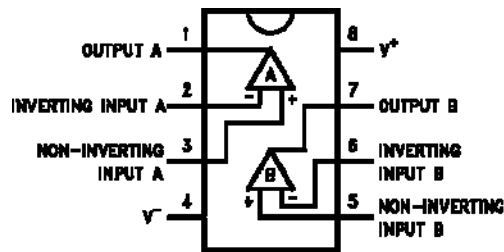

Figure 8: Pinout of the OP284 op-amp.

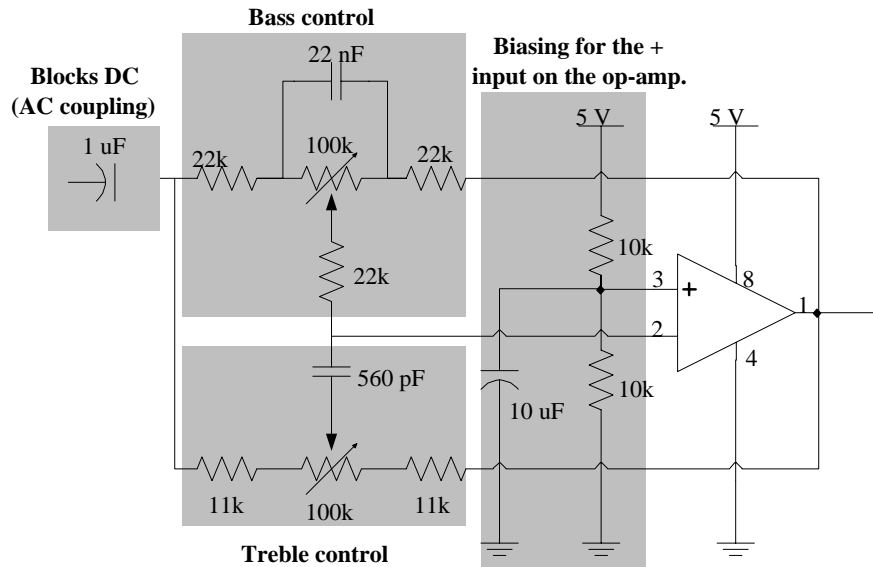

Figure 9: Examining the tone control circuit.

6 Playing With It Once you have this built, reconnect your audio player and power it up. Play with the volume, bass, and treble knobs. How does it sound?

7 Measuring the Transfer Function Recall that the transfer function of a circuit is simply a plot the output voltage divided by the input voltage for a range of frequencies. We could simply plot V_{out}/V_{in} or we could plot the same thing in decibels ($20 \cdot \log_{10}(V_{out}/V_{in})$). In the case of this audio circuit, it is more meaningful to plot the transfer function in decibels since this directly relates to the change in volume.

Set the treble, bass, and volume knobs to something interesting (not a flat response – distort it slightly). Now disconnect your audio player and headphones. Connect the signal generator in place of your audio amplifier. Use 100 mV pp, 0 V offset. Connect two oscilloscope probes to the circuit, one at the input (male headphone jack) and one at the output (female headphone jack). Use the oscilloscope to measure the peak to peak voltage at both the input and the output. Follow the template given in the lab write-up to sweep the input frequency, and use the attached graph to sketch the transfer function of this circuit.

REVISION HISTORY

Name	Date	Note
David Lin	7/28/05	Revised Fall 2004 audio amplifier project for use with <12V supply and summer schedule.