

[www.erich-ott.de](http://www.erich-ott.de)



**ERICH OTT** 

Erich Ott GmbH & Co. KG  
Partner für den Ex-Bereich

D- 65189 Wiesbaden  
Rüdigerstrasse 15  
Telephone +49 (0) 611 - 76 13 93  
Telefax +49 (0) 611 - 71 14 62

mail [info@erich-ott.de](mailto:info@erich-ott.de)  
web [www.erich-ott.de](http://www.erich-ott.de)

## Ex S GH ... ALAT

System heat conductor connector with appropriate heating cables

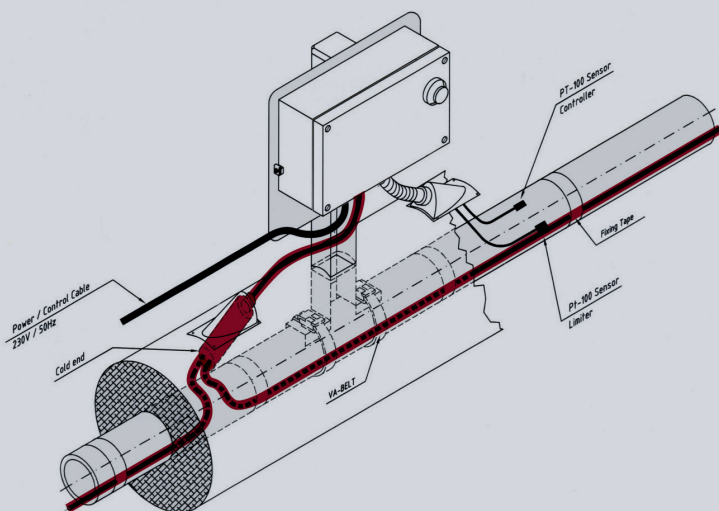

Identification		<b>II 2 G Ex eb mb II C T1-T6</b> <b>II 2 D Ex mb IIIC T... °C</b>
EU type examination certificate		<b>PTZ 16 ATEX 0021X</b>
Ambient temperature range		<b>-40°C to +80°C</b> <small>(je nach Heizleiterverbinder)</small>
Heat output		<b>80 W/m</b> <small>(je nach Heizleiterverbinder)</small>
Max. admissible nominal current		<b>16A/ 32 A</b>
Nominal voltage		<b>230V</b>
Degree of protection		<b>IP65</b>

Heating cable mineral insulated	Heat conductor connector
Heatchem H321-A / H600-A / H400	GH/ GHL
Pentair (Raychem) HDC / HDF	
Pentair (Raychem) HSQ / HIQ	
Pentair (Rachem) HAX	
Thermon MIS / MIQ	
ISOHEAT-MI-FHC	
Heating cable PI	Heat conductor connector
Pentair (Raychem) XPI / XPI-S	GHT
Self-regulating heating band	Heat conductor connector
Pentair (Raychem) BTV	GHP

### Connecting fitting

The system certificate contemplates the heat conductor connector in conjunction with the respectively corresponding heating cables. This system certificate facilitates an explosion control contemplation during the installation at the end customer and at the designated testing facility. The system is certificated for Ex zone 1 and 2.

Quick and cost-effective due to on-site installation and cold sealing compound. Advantage of this: The heating only starts at the pipe, connection fitting is strapped to the pipe. In this way no loss of heat occurs in the air between junction box and pipe, transition piece between protective box and heating differential pressure pipe.

For heat traces intended for use in explosion-hazard areas according to directive 2014/34/EU.

## INHALTSVERZEICHNIS

1.0	Description .....	2
2.0	Technical data .....	2
3.0	Ordering information .....	3
3.1	Ordering code.....	3
3.2	Scope of delivery .....	3
4.0	Necessary accessory .....	3
4.1	Installation accessories .....	3
4.2	Heating cables polymerized (Pi) for GHT .....	3
4.3	Heating cables mineral insulated for GH / GH L .....	3
4.4	Parallel heat bands self-limiting for GHP .....	4
5.0	Installation of the heating cable .....	4
6.0	Start-up of the heating circuit .....	5
7.0	Heating cables .....	5
8.0	Short-time overload in case of failure .....	5
9.0	Technical data of the heating cables .....	5
10.0	Reference points .....	5
11.0	Control of systematical and random errors without interruptions .....	5
12.0	Type plate .....	6



### Warning

The installation, configuration and commissioning must be carried out only by trained persons. On-site installation and safety instructions must be observed. Failure to comply assembly and storage requirements will void the warranty and if applicable the certificate level. If, during different way of looking at various possibilities of a heat conductor load, for safety the highest value of heat output must be assumed.



### Proviso

Technical alteration without prior notice.. Changes, errors and typographical errors do not justify any claim for damages For safety components and systems the relevant standards and regulations must be observed as well as the corresponding operating and assembly instructions.

### Maintenance / Servicing

For the maintenance / servicing and examination the regulations according to EN 60079-14 are valid. The equipment is maintenance-free when it is used properly.



### Installationshinweise

The valid regulations for the commissioning / maintenance / service /examination of the EN 60079-0, EN 60079-7 and EN 60079-18, if applicable, must be observed or rather considered.

The equipment is maintenance-free when used properly. However, damages can occur at the connection fitting due to external impacts. Should these cause adverse effects of the cable connector, it must be replaced by a new installation. The dismantling is carried out by cutting off the heat conductor loop. A repair is not possible due to the potting.

For the connection of heating cables made of PTFE, it must be observed, that these have a strong longtime cold flow behaviour. This does not cause any problems inside the cable connector itself, as the potting prevents a leakage of the material. But outside of it a flow of the PTFE can be recognized over longer periods. For this reason the insulation must be checked after a reasonable period. If difficulties should occur during the commissioning anyway, we ask you not to carry out any unauthorised manipulations. Otherwise the warranty and the validity of the EU-type examination certificate void. Please contact us. In the case of service the device must be sent back to our company for examination.

The installation instructions published by the cable manufacturers for each type of heating cable must be observed additionally (fixed resistance heat conductor) If it is not attached to the delivery, please request it.



### Special conditions

1. The operating manual must be observed. Especially with regard to the maximum temperatures of the corresponding versions.
2. The temperature class results from the consideration of the maximum supplied power input, the installation conditions and the particular operating and environmental conditions. The determination for the standard application cases is carried out in accordance with the specifications of the manufacturer considering the determinations and indications in the operating manual. A phase failure at three-phase networks must be considered.
3. The heating cable needs a temperature controller to keep product temperatures constant. To maintain a permissible limit temperature, an additional temperaturerlimiter is necessary. Above mentioned devices must be suitable for the stress during operation.
4. The combination of the respective line connector and the appropriate heating cable with separate EU type examination certificate is determined by the manufacturer according to this EU type examination certificate and shall not be modified.
5. To each heating system a suitable excess power protection device must be upstreamed, which reliably prevents even inadmissible earth fault currents.
6. Prior to commissioning an insulation test must be executed.



### Repair

The device is irreparable.

Read through this operating manual carefully before to take the device into operation. Keep this operating manual at a place that is accessible for all users at any time.

Please support us to improve this operating manual. We are grateful for your suggestions.

Contact us for technical queries!  
 TELEPHONE: +49 (0)611 761 393  
 TELEFAX: +49 (0)611 711 462  
 E-Mail: info@erich-ott.de

## 1.0 DESCRIPTION

### Characteristics

- connection coupling for all common types of heating cables
- easy installation
- no heating necessary
- 20 years of use
- pre-assembled casting compound
- Screw-/ clamp fastening by use of M24 nut



The system certificate contemplates the heat conductor connector in connection with the corresponding heating cables. This system certificate facilitates an explosion control contemplation during the installation at the end customer and at the designated testing facility. The system is certified for Ex zone 1 and 2.

Part of this operating manual is the separately available operating manual Ex GH.ALAT or rather Ex GHL ALAT.

It is available for download under [www.erich-ott.de](http://www.erich-ott.de).

The system consists of the designated types of heating cables and the

connection fittings, which consist of 2 components, that must be ordered separately.

- a. The heating cable connector incl. clamping part / sleeve and connection fitting
- b. The cast resin components A and B



Additionally a duct can be ordered, which facilitates the assembly execution out of the insulation and produces a clear and professional connection point. If the heat conductor connector should be connected to an assembly iron or similar, a M24 nut is placed standard above a thread in delivery state.

The fully assembled connection is preferably fixed as loop outside the isolation or under the isolation directly on the pipeline. At this the maximum ambient temperatures of the EU type examination certificate as well as the indications of this operating manual must be observed.

The cross-sections of the supply line as well as the material and the length of the connection cable must be specified from the type code of the operating manual Ex GH... ALAT bzw. EX GHL ALAT.

Heating cable mineral insulated	Type examination certificate	Heat conductor connector
Heatchem H400 / H600-A / H321-A	SIRA10ATEX3216	GH/ GHL
Pentair (Raychem) HDC / HDF	Baseefa02ATEX0045U	
Pentair (Raychem) HSQ / HIQ	Baseefa02ATEX0045U	
Pentair (Raychem) HAX	Baseefa02ATEX0045U	
Thermon MIS / MIQ	ISSeP12ATEX004U	
TraceTec (ISOHEAT) ISOHEAT-MI-FHC	BVS12ATEX041U	
Heating cable PTFE - insulated		Heat conductor connector
Pentair (Raychem) XPI / XPI-S	PTB08ATEX1088U	GHT
Self-regulating heating band (parallel)		Heat conductor connector
Raychem (BTV)	PTB09ATEX1115X & Baseefa06ATEX0183X	GHP

## 2.0 TECHNICAL DATA

Cable diameter heat conductor	3,2 mm to 5,8 mm	
Max. power loss per m heating cable: Cast resin fitting (GH) (GHT) (GHP) (GHL)	22 W/m (at +40°C ambient temperature) 15 W/m (at +40°C ambient temperature) 22 W/m (at +40°C ambient temperature) 80 W/m (at +40°C ambient temperature)	
Current type	Direct or alternating voltage	
Nominal voltage of the connector	230 V	
Max. admissible nominal current	16A/ 18A (or rather. 16/ 32A for GHL)	
Connection cable	1,5 mm <sup>2</sup> or 2,5 mm <sup>2</sup> EVA, PTFE or Silikon	
Degree of protection	IP65/ DIN 40 0 50	
Dimensions: GH GHT + GHL + GHP	85 x 32 mm 100 x 32 mm	
Fixing hole	26 mm	
PE connection box (optionally)	75x80x55 mm (also see point 10)	
Temperature at the heat conductor connector GH/ GHT	max. 70°C ( applicable at max. permissible power dissipation at the entrance of the heat conductor into the cast resin)	
Temperature at the heat conductor GHL	max. 180°C (applicable at max. permissible power dissipation at the entrance of the heat conductor into the cast resin)	
Ambient temperature range	-40°C to +40°C /+60°C (respectively. +80°C GHL) for accordingly adjusted heat power	
EU type examination certificate	PTZ 16 ATEX 0021X	
Type of ignition protection (Gas)	II 2 G Ex eb mb II C T1-T6	
Identification	 0344	 II 2 G Ex eb mb II C T1-T6 II 2 D Ex mb IIIC T... °C

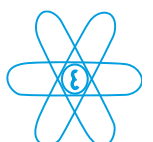

Please take detailed information for the installation from the product data sheets.

Included heating cables as well as spike-strip with spring clips made of CR-Ni steel, stainless steel gauze bandages, adhesive aluminium tape, etc. can be ordered from us on demand as well. See installation accessories.

## 3.1 ORDERING CODE

Ex 

1	GH	2	ALAT	3	4	5	6	7
---	----	---	------	---	---	---	---	---

1	S	system certificate (PTZ16ATEX0021X)
2	-	for mineral insulated heating cable (GH =22W/m)
	T	for plastic insulated heating cable
	P	parallel heat conductor self-regulating
	L	for mineral insulated heating cable (GHL =80W/m)
3	-	standard connection cable 1,5 mm <sup>2</sup> 230 V
	400	connection cable 2,5 mm <sup>2</sup> 400 V
4	-	standard version
	S	with protective hose stainless steel A2
	M	excenter connector (sleeve)
5	-	standard connection cable (EVA) up to 110°C 1,5 mm <sup>2</sup>
	P	connection cable made of PTFE 1,5 mm <sup>2</sup>
	P 2,5	connection cable made of PTFE 2,5 mm <sup>2</sup>
	S	connection cable made of silicone 1,5 mm <sup>2</sup>
	S 2,5	connection cable made of silicone 2,5 mm <sup>2</sup>
6	-	standard
	va	version "stainless steel"
7	-	standard length connection cable: 1,2 m
	...	length in plain text, (available lengths: 0,5 - 5 m)

Example: system with plastic insulated heating cable, standard protective hose, connection cable made of PTFE, version „stainless steel“, length of the connection cable : 1,2 m:

Ex 

1	S	GH	T	ALAT	3	4	P	VA	6	7
---	---	----	---	------	---	---	---	----	---	---



Attention! The casting compound is a necessary accessory and must be ordered separately. See the data sheet Casting compound for the ordering indications.

**Complete the type plate at the cable connector**

## 3.2 SCOPE OF DELIVERY

### Connection fitting

1. Clamping body with connecting lead preassembled
2. Sleeve
3. Strain relief with studded disk
4. Screw and loss protection
5. O - ring and nut M24x1,5
6. Type plate
7. 2-ear hose clamp with protective hose (double) (only GHT)

## 4.0 NECESSARY ACCESSORY

1	2855-T125	Cast resin components A and B	GH/ GHT
2	2855-T125L	Cast resin components A and B	GHL

### Scope of delivery 2855-T125



### Scope of delivery 2855-T125L



1 can component „A“, 1 can component „B“, 1 wooden spatula

Please take further information from the data sheet Cast Resin 2855-T125 or 2855-T125L on [www.erich-ott.de](http://www.erich-ott.de)

## 4.1 INSTALLATION ACCESSORIES

Nr.	Order code	Product
1	IE	Insulation insertion
2	CP 944	Adhesive aluminium tape Coroplast 0,9mmx50mx 5m
3	EG 5	Stainless steel gauze bandages 50mm x 10m (Woven wire band)
4	EG 10	Stainless steel gauze bandages 100mm x 10m
5	GB	Filament glass band raw 0,15mm x 10mm x 100m
6	KB	Spike strip with spring clips made of CR-NI-steel 1m
7	MS D	Marking label german (see point 7.0)
8	MS E	Marking label english (see point 7.0)

## 4.2 HEATING CABLE POLYMERIZED (PI) FOR GHT

Please indicate the reference number (resistance) according to the manufacturer. Also the desired length of cable.

	Manufacturer	Type	Resistance of the heating cable	Length of the cable
1	Pentair (Raychem)	XPI / XPI-S	0,8 - 8000 Ω /KM	xx m

## 4.3 HEATING CABLE MINERAL INSULATED FOR GH / GHL

	Manufacturer	Type	Resistance of the heating cable	Length of the cable
1	Pentair (Raychem)	HDC / HDF	7 - 1600 Ω /KM	xx m
2	Pentair (Raychem)	HSQ	250 - 10000 Ω /KM	xx m
3	Pentair (Raychem)	HIQ	250 - 10000 Ω /KM	xx m
4	Pentair (Raychem)	HAX	105 - 36.000 Ω /KM	xx m

5	Heatchem	H400 (HDF/HDC)	7 - 1.600 Ω /KM	xx m
6	Heatchem	H600-A (HIQ)	250 - 10.000 Ω /KM	xx m
7	Heatchem	H321-A (HSQ)	250 - 10.000 Ω /KM	xx m
6	Thermon	MIS	160 - 10.000 Ω /KM	xx m
8	Thermon	MIQ	160 - 10.000 Ω /KM	xx m
9	ISOHEAT	MI-FHC	250 - 10.000 Ω /KM	xx m

#### 4.4 PARALLEL HEAT CONDUCTORS SELF-REGULATING FOR GHP

	Manufacturer	Type	Heat capacity	Length of cable
1	Pentair	BTV	25 W/M bei 10°C	xx m

#### 5.0 INSTALLATION OF THE HEATING CABLE

The installation of the PI-heating cables XPI/XPI-S is carried out according to the installation mounting instructions of HEW-THERM\*. \* (Pentair Thermal Management)

The installation of the MI-heating cables must be carried out according to the mounting instructions of the respective manufacturer.

The mounting instructions for self-regulating and power limiting heating bands can be found on: [https://www.pentairthermal.de/Images/DE-RaychemSelfRegCable-IM-DOC71\\_tcm485-56066.pdf](https://www.pentairthermal.de/Images/DE-RaychemSelfRegCable-IM-DOC71_tcm485-56066.pdf).

##### Inspection prior to commissioning

Check the type of the heating cable and compare the individual indications on the delivery not with the catalogue numbers of the heating cable to find out, if the correct material has been delivered.

The operating temperature may not exceed the values indicated in the product literature of the heating cable manufacturer. Check, if the expected operating temperature lies within the range.

Ensure, that the nominal voltage of the heating cable is rated for the operating voltage. The heat conductor may not be connected to a mains voltage as long as it is still rolled up.

##### Removal of the heating cable from the barrel

The heating cable may only be removed stretched from the barrel. The removal of the heating cable from the barrel via shackle is prohibited. This kind of handling can cause damages at the heating cables and lead to breakdown of the heating circuit. Use suitable decoilers!

Only unwind the heating cable according to draft!

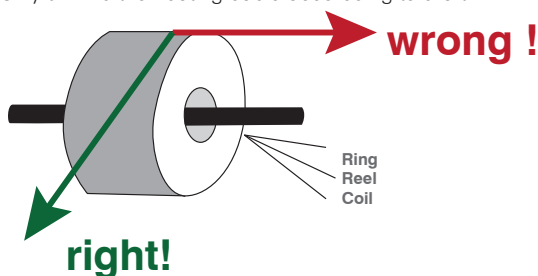

##### Alignment of the heating cable to pipe or vessel

During the installation of the heating cable it must be ensured, that e.g. loops, which accrued during the alignment, are unbundled thoroughly. Stretching of the heating cable under high tension leads to damage of the heating cable. A barrel roll (torsion) must be avoided.

##### Mechanical load of the heating cable during the installation

The heating cable must be protected against extreme mechanical loads. These include among other things the rolling over by vehicles or heavy reels, the collision of the reels, whereat the drum flanges are pressed against the heating cable and the pulling of the heating cable over sharp edges.

##### Recommendation for laying the heating cables at the pipe

Two, three or more heating cable harnesses can be laid parallelly along the pipe. For horizontally running pipelines the cable harnesses should be fixed in the area of the pipe circumference (4-8 o'clock position). This position supports the heat dispersion.

##### The laying interval of 10 mm should not be undercut.

**If it nonetheless comes to laying intervals less than 10 mm, the maximum permissible power must be reduced in W/m. A surface temperature higher than the permissible temperature of the heating cables must be avoided at all costs. Also the temperature class in the explosion protection document may not be exceeded.**

##### Fixation of the heating cables at pipelines and containers

For fixing the heating cable at the pipe in intervals of approx. 30 - 40 cm, filament glass bands, adhesive aluminium tapes or assembly belt of stainless steel (spike strips) can be used. In this process the heat conductor must be moveable at the designated points after the installation. A completely strong connection can in operation lead to the breakdown of the heating circuit, as the risk of a cable break is available. Intersections of the cables must be avoided during the installation. (For MI-cable stainless steel gauze bandages are recommended)

##### Installation of the cable!

Which fastening elements should be used for the installation can be found in the installation instructions of the manufacturer for the respective heating cable.

##### Keep the bending radius!

Please follow the installation instructions of the manufacturer for the respective heating cable.

##### Avoid cable torsions and Klanken verhindern!

During the laying works at the pipe it must be ensured, that the heating-cables are mounted at the pipe without loop knots and torsions. The cable movement due to the heat work in operation leads to line breaks at such positions.

##### Bending of the heating cable after the outlet out of the cable connector

The bow to be positioned at the tube must have a bending radius larger than  $r=8xd$ , it is formed after the encapsulation. Not valid for MI-cables!

For MI-cables no other bending radius may be positioned directly at the encapsulation after the encapsulation. If bending takes places subsequently, the respective conductor end must be fixed between tube and bow. The minimum distance of the bending process is, if the forces during the bending only affect on one end of the MI-cable, pursuant to the following table:

Outer diameter of the lead	Distance (mm)	Outer diameter of the lead	Distance (mm)
3,2	22	3,9	40
3,4	26	4,3	50
3,6	31	4,7	70
3,7	35	5,3	100

**If it can not be avoided that while bending forces are transmitted on the tube or the other conductor end, the 2,5-fold distance applies.**

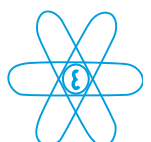

## 6.0 STARTUP OF THE HEATING CIRCUIT

Prior to commissioning of the heating circuit the resistance of the heat conductor, the supply voltage, the setting of the temperature at the controller and limiter must be checked. Also the electrical and thermal specifications of the projecting must be checked.

The insulation test must be carried out according to the requirements of the DIN EN 60079-30-1 or according to the requirements of the cable manufacturer.

### Additional marking

For the labelling of electrically heated pipelines marking stickers must be affixed in appropriate distances (approx. 3m) on the thermal insulation. Identify the mounting location of the accessory that belongs to the heating system (e.g. cable connector) outside of the thermal insulation.

For the marking of the heating systems stickers with the following inscription:



Order number	MSD	See point 4.1
--------------	-----	---------------



Order number	MSE	See point 4.1
--------------	-----	---------------

## 7.0 HEATING CABLES

The technical data as well as the available heating cables from Pentair (Raychem) XPI must be learned from the data sheets of the company Pentair Thermal Management. The data does only apply in so far as it is not determined differently by the data of the EU-type examination certificate.

### Substantial difference during the installation of MI-cable opposite to the installation of the installation of the PI-cable:

- For fixing also deflection wire and wire mesh belt can be used.
- A bow of the 3-fold of cable diameter may not be bended up again, only from the 6-fold up it can be bended bidirectionally more often. This must be avoided.
- The technical data as well as the available heating cables from Heatchem H321-A, H600-A and H400 can be taken from the data sheets of the company Heatchem Oy, Palilanraitie 9, FI-00240 Helsinki. The data does only apply in so far as it is not determined differently by the data of the EU-type examination certificate.
- The heat conductor may not be bended directly at the cable connector. The installation instructions of the respective heating cable manufacturers (fixed resistor heat

conductor) for the respective type of heating cable must be observed additionally. If not attached to the delivery, please request for it.

## 8.0 SHORT-TIME OVERLOAD IN CASE OF FAILURE

As the mass of the cable connector is big compared to the heating cable, the values of the heating pipe are valid for the time in which no external temperature increase of the cable connector is to be expected.

## 9.0 TECHNICAL DATA FOR THE HEATING CABLES

Pentair (Raychem) XPI / XPI-S :	
Resistance range	0,8 to 8000 Ω/km at 20°C
Nominal power	0 to 35 W/m
Operating temperature range	-70°C ... +260°C
Mineral insulated cable HSQ/HIQ/HDF/HDC:	
Nominal power	0 to 150 W/m
Operating temperature range	-40°C ... +450°C
Resistance range HSQ / HIQ	250 to 10000 Ω/km at 20°C
Resistance range HDF/HDC	7 to 1600 Ω/km at 20°C
Resistance range HAX	105 - 36.000 Ω /km at 20°C
Parallelheizband Selbstregelnd BTV:	
Nominal power	0 to 25 W/m at 10°C
Operating temperature range	-60°C ... +85°C

The ambient temperature range can be +50°C at a reduction of 2/3 of the maximum nominal power.

Individual certificates: ZELM 03 ATEX 0169U, PTB08ATEX1088U, Baseefa02ATEX0046U, SIRA02ATEX3260 and Baseefa06ATEX0183X.

## 10.0 REFERENCE POINTS

If the desired temperature behaviour of a heating is not achieved by means of the physical conditions after the installation\*, this is realized by one or more reference points and other measures. See in this respect notes on information sheet V reference points (\*exception insufficient temperature)

## 11.0 BEHERRSCHUNG SYSTEMATISCHER UND ZUFÄLLIGER FEHLER OHNE AUSFÄLLE

See in this respect information sheet I „Cases of failure at electrical surfaces and protective box heating systems“. It offers a an overview of systematical and random errors or breakdowns. To detect these errors and react defined can be determined for each operation only restrictedly.

## 12.0 TYPE PLATE



1-	Type of ignition protection	6-	Supervisory agency
2-	Nominal voltage	7-	Type designation
3-	Operating voltage	8-	Inspection body/ EU - type examination certificate
4-	Nominal current	9-	Heat conductor
5-	Ex marking	10-	Serial number

