

ROYAL FILTERMIST FX Series

Catalog and Price List



**Low Cost, Highly
Efficient Mist
and Smoke
Collectors
Designed
Specifically
for the
Metalworking
Industry**



Eliminate Mist and Smoke in Your Shop

Why Control Oil Mist and Smoke in Your Shop?	3
Common Mist Collection Methods	4–5
How Does the Royal Filtermist Work?	6
FX Series Design Enhancements	7
Why is the Royal Filtermist the Best Choice for the Metalworking Industry?	8
Risk-Free Performance Guarantee	9
Filtermist Performance Accessories	10–11
Mounting	12–13
Choosing the Correct Filtermist Unit	14–15
Efficiency	16
Commonly Asked Filtermist Questions	17
Model FX-275	18–19
Model FX-550	20–21
Model FX-900	22–23
Model FX-1200	24–25
Filtermist Maintenance	26
Replacement Parts	27–28
Filtermist Ordering Sheet	29



Division of Curran Manufacturing Corporation

200 Oser Avenue
Hauppauge, New York 11788

Tel: 1-631-273-1010
Fax: 1-631-273-1066

Toll-Free USA and Canada
Tel: 1-800-645-4174
Fax: 1-800-424-2082

Email: info@royalprod.com
www.royalprod.com





For over 30 years, the Royal Filtermist has been effectively collecting mist and smoke generated by all types of metalworking machinery.

There are currently more than 125,000 units operating in over 40 countries worldwide, making Filtermist the world leader in metalworking pollution control equipment.

Throughout its history, the Royal Filtermist has undergone continuous design advances. The Filtermist FX represents the ninth generation of Royal Filtermist, and is the result of extensive computer-aided modeling and testing. Based upon the well-established principle of centrifugal impaction, the Filtermist FX incorporates a series of improvements that have resulted in the most advanced and effective system available for the removal of mist and smoke created by metalworking machinery.

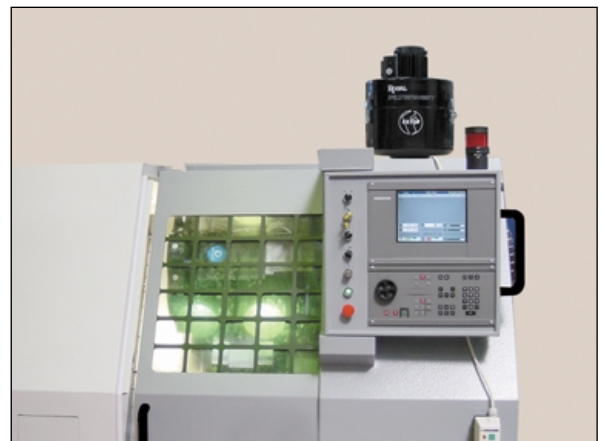

This catalog will help you learn how the Royal Filtermist can make your shop a cleaner, safer, and healthier place to work. It contains all of the information you will need to make an educated purchasing decision — including prices.

We have also produced a nine-minute video to further explain the many advantages offered by the Royal Filtermist. If you didn't receive a copy of the video with this catalog, you may view it on our website at www.mistcollectors.com, or you can contact our customer service department at 1-800-645-4174 for a free copy.

Thank you for considering Royal Filtermist for your shop. We look forward to working with you.

A ROYAL FILTERMIST FOR EVERY APPLICATION



The low-cost, highly efficient Royal Filtermist effectively collects mist and smoke generated by all types of machines, including:

- CNC Lathes
- Machining Centers
- Grinders
- Swiss-Style CNC's
- Screw Machines
- EDM Machines
- Manual Lathes
- Milling Machines
- Injection Molding Machines
- Rotary Transfer Machines
- Gear Hobbers
- Cold Heading Machines
- Aqueous Parts Washers
- Vacuum Pumps
- Printing Presses
- Baking Lines
- Some Heat Treating Processes





- **Reduced Health Risks**
Any form of pollution is potentially dangerous to the lungs, larynx, and skin.
- **Reduced Accident Risks**
Oil mist creates slippery surfaces which increase accident rates.
- **Reduced Fire Hazards**
Oil deposits create a serious fire risk by allowing fires to spread quickly.



- **Coolant Cost Savings**
The Royal Filtermist recycles coolant and returns it to your machine rather than venting it to the atmosphere.
- **Heating and Cooling Cost Savings**
The Royal Filtermist returns clean air to the shop instead of exhausting it outdoors.
- **Cleaning and Maintenance Cost Savings**
Uncontrolled airborne mist and smoke deposits result in more frequent cleaning of exposed surfaces.
- **Fewer A/C Service Calls**
The Royal Filtermist helps reduce breakdowns of shop air conditioning equipment by preventing mist from contaminating the intake filters.



**INCREASED
PRODUCTIVITY**

- **Improved Employee Attendance**
A contaminated shop environment often results in higher worker absenteeism and lower morale.
- **Less Machine Downtime**
Fouled contacts in electronic equipment cause expensive downtime.
- **Higher Speeds and Feeds**
Machining operations can run at higher speeds and feeds without the negative effects of increased mist and smoke production.
- **Better Lighting**
Haze from mist and smoke and grimy buildup on shop lighting fixtures cause even the most well-lit shops to take on a dingy appearance. Bright, cheerful environments improve employee morale and performance.



- **Fewer Workmen's Compensation Claims**
The increase in workmen's compensation rates from one large claim can cost more than an air cleaning system for an entire factory.
- **Government Regulations**
The current OSHA and NIOSH limits on airborne oil mist are 5 mg/cubic meter, and this requirement is expected to become even stricter in the future. The Royal Filtermist exceeds both the current and new proposed limits.



- **Moral Concerns — You Owe It To Your Employees**
They deserve a workplace that is as hazard-free as you can make it. One customer, when asked why he wanted to control the oil mist and smoke in his plant, responded, "I wouldn't expect my office people to work with smoke pouring out of their computers, and I sure don't expect my shop workers to work on machines with oil mist pouring out of them!"

In order to fully understand why the Royal Filtermist is the best choice for handling oil mist and smoke produced by the metalworking industry, it is important to have some general knowledge of how other types of collection systems work. This section contains an overview of the most common methods for controlling mist and smoke. While these systems all have some positive features, their drawbacks make them unsuitable for use in most metalworking applications.

External Venting

At one time, the only method for controlling oil mist and smoke in a shop was to vent it out of the building. This was done either by opening the doors and windows or installing a ventilation system. While this method may look like an attractive low-cost solution, the potential dangers should be enough to make any shop owner reconsider this practice.

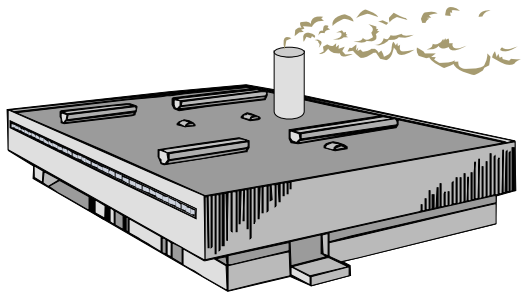

Environmental Hazards Today, it is illegal in many states to exhaust pollutants to the atmosphere. Offending companies run the risk of large fines and lawsuits.

Fire Hazards Over time, oil deposits collect in the ductwork of ventilation systems, making them prime targets for flash fires and providing pathways for fires to spread quickly.

Cleanliness Problems As mist and smoke travels through a shop to the exhaust points, it collects on exposed surfaces. Over time, a grimy buildup occurs on machines, lights, floors, and walls, resulting in dirty, unsafe conditions.

Media-Type Filtration Systems

Media-type filtration systems typically consist of a blower and several filters of varying efficiencies. The contaminated air first passes through a coarse pre-filter where the largest particles are filtered out. It then moves through one or two medium-range filters before reaching the final filter, which is usually made from a high-efficiency HEPA material. Media-type systems are good at collecting dry contaminants such as welding smoke and graphite dust. However, they are often not suitable for metalworking applications where coolant mist is the primary contaminant.

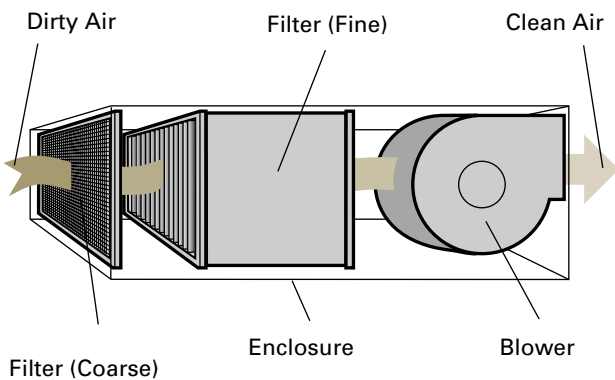

High Operating Costs The biggest drawback of media-type filtration systems is the high operating cost associated with replacement filters. Because these filters are designed to retain contaminants, they will become clogged with use. Usually they are made from media that cannot be cleaned, so the only alternative is replacement. Depending upon the cost of the filters and the replacement frequency, this type of system can be quite expensive to operate over the long term.

Decreased Throughput Another problem with multi-stage filter units is that the throughput of the system, measured in cfm, decreases as contaminants become trapped in the pores of the filters. It is important to maintain the correct throughput of any collection system. Reduced throughput means reduced collection, allowing contaminants to escape into the shop air.

Not for Mist Most media filters are designed to collect dry pollutants such as smoke and dust. Exposure to coolant and oil mist may damage certain types of filter media.

Electrostatic Precipitators

Electrostatic precipitators use a blower to draw mist and smoke particles past an ionizer, which imparts a positive charge to them. They then pass across a series of alternately like-charged and grounded collection plates. The particles are repelled by the like-charged plates and forced towards the grounded plates where they collect. The filtered air is returned to the shop.

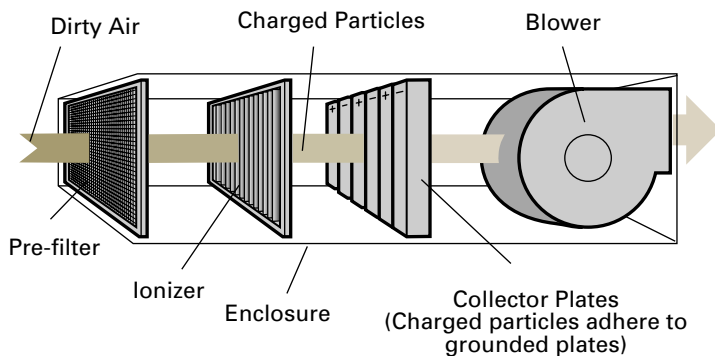

Variable Efficiency Although electrostatic systems are very efficient when the collection plates are clean, the efficiency drops off drastically as the plates become covered with particles. Each time a particle deposits on a plate, it eliminates a spot for other particles to adhere to.

Maintenance Costs To maintain high efficiency, the collection plates must be cleaned often. This can be expensive because the residue is considered to be hazardous waste and must be disposed of by a certified waste handling company. Many electrostatic systems are sold with costly maintenance contracts, resulting in operating costs that greatly exceed the original unit purchase price.

Health Hazards As the collection plates become full, a phenomenon known as arcing can occur. This arcing results in the production of ozone, which has been found to cause a variety of health problems. This potential danger (and the fear of lawsuits) has caused many U.S. companies to remove electrostatic units from their factories.

The Dangers of Ozone

Ozone produced by electrostatic precipitators presents a significant health risk to humans. Here's what OSHA and the EPA have to say about ozone on their websites:

OSHA

Ozone is highly injurious and potentially lethal to experimental animals at concentrations as low as a few parts per million (ppm). A study in which young mice were exposed to 1 ppm ozone for 1 or 2 days reported damage to alveolar tissue. Human populations chronically exposed to lower concentrations of ozone were observed to have adverse changes in lung function. Human volunteers exposed to 0.5 ppm ozone for 3 hours per day, 6 days per week, for 12 weeks showed significant adverse changes in lung function. Another report showed a 20 percent reduction in timed vital lung capacity in persons exposed to average concentrations of ozone of 1.5 ppm for 2 hours. <http://www.osha.gov/dts/sltc/methods/inorganic/id214/id214.html>

EPA

Breathing ozone can trigger a variety of health problems including chest pain, coughing, throat irritation, and congestion. It can worsen bronchitis, emphysema, and asthma. "Bad" ozone also can reduce lung function and inflame the linings of the lungs. Repeated exposure may permanently scar lung tissue. <http://www.epa.gov/oar/oaqps/gooduphigh/>

With these health (and potential lawsuit) risks, many companies have established policies that ban the use of electrostatic mist collectors in their facilities.

HOW DOES THE ROYAL FILTERMIST WORK?

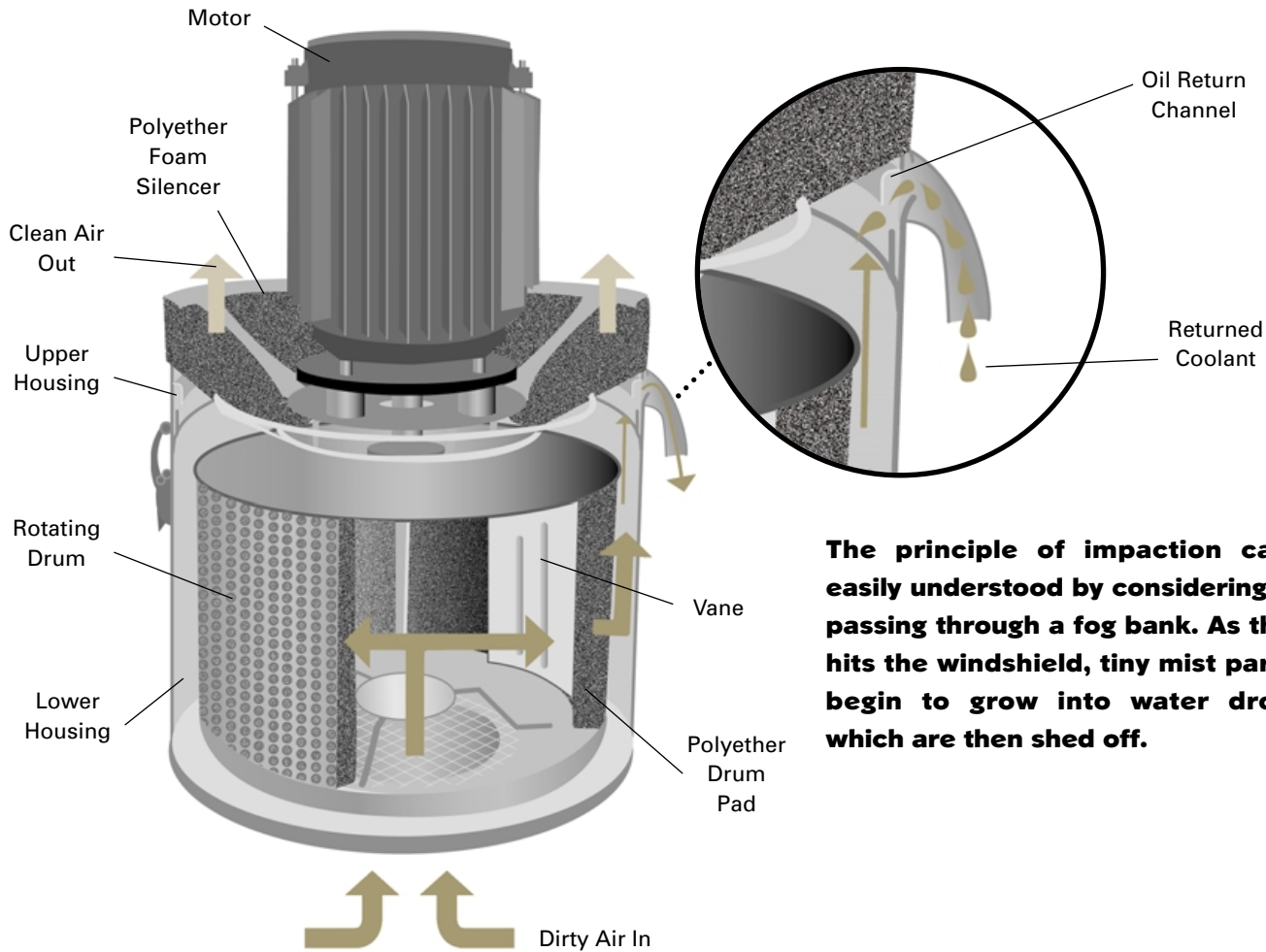

The principle of impaction can be easily understood by considering a car passing through a fog bank. As the fog hits the windshield, tiny mist particles begin to grow into water droplets which are then shed off.

The Royal Filtermist uses the principle of centrifugal impaction to eliminate mist. With only three main components: a drum, a motor, and the housing, its operation is quite simple.

1. A three-phase motor rotates the internal drum at high speed, creating a vacuum which draws mist particles into the center of the drum.
2. The mist particles then collide with the rotating drum's vanes and are forced together with other particles, causing them to coalesce and form larger, droplet-sized particles.
3. As the particles grow into droplets, they pass through the perforations in the rotating drum and centrifugal force causes them to be thrown onto the inner wall of the housing.
4. The particles are then forced, under pressure, up the walls of the housing to the oil return channel, where they are subsequently drained back to the machine's coolant tank.
5. Clean, oil-free air blows past the motor and is returned to the shop.
6. Since this process relies on the mechanical principle of centrifugal impaction and the rotational speed remains constant, the Royal Filtermist maintains a continuous high efficiency.
7. For certain applications that produce smoke and/or very fine mist particles, an after filter may be required. This filter easily mounts to the top of the Filtermist unit by slipping over the motor and it is secured in place with two toggle clips. An after filter mounted to a Royal Filtermist typically enjoys a comparably long service life because most contaminants are removed by the impaction process prior to reaching the filter.

The Royal Filtermist FX Series is the ninth generation of Filtermist. FX Models incorporate a number of design improvements over previous versions to provide the most advanced and effective system available for the removal of mist and smoke.

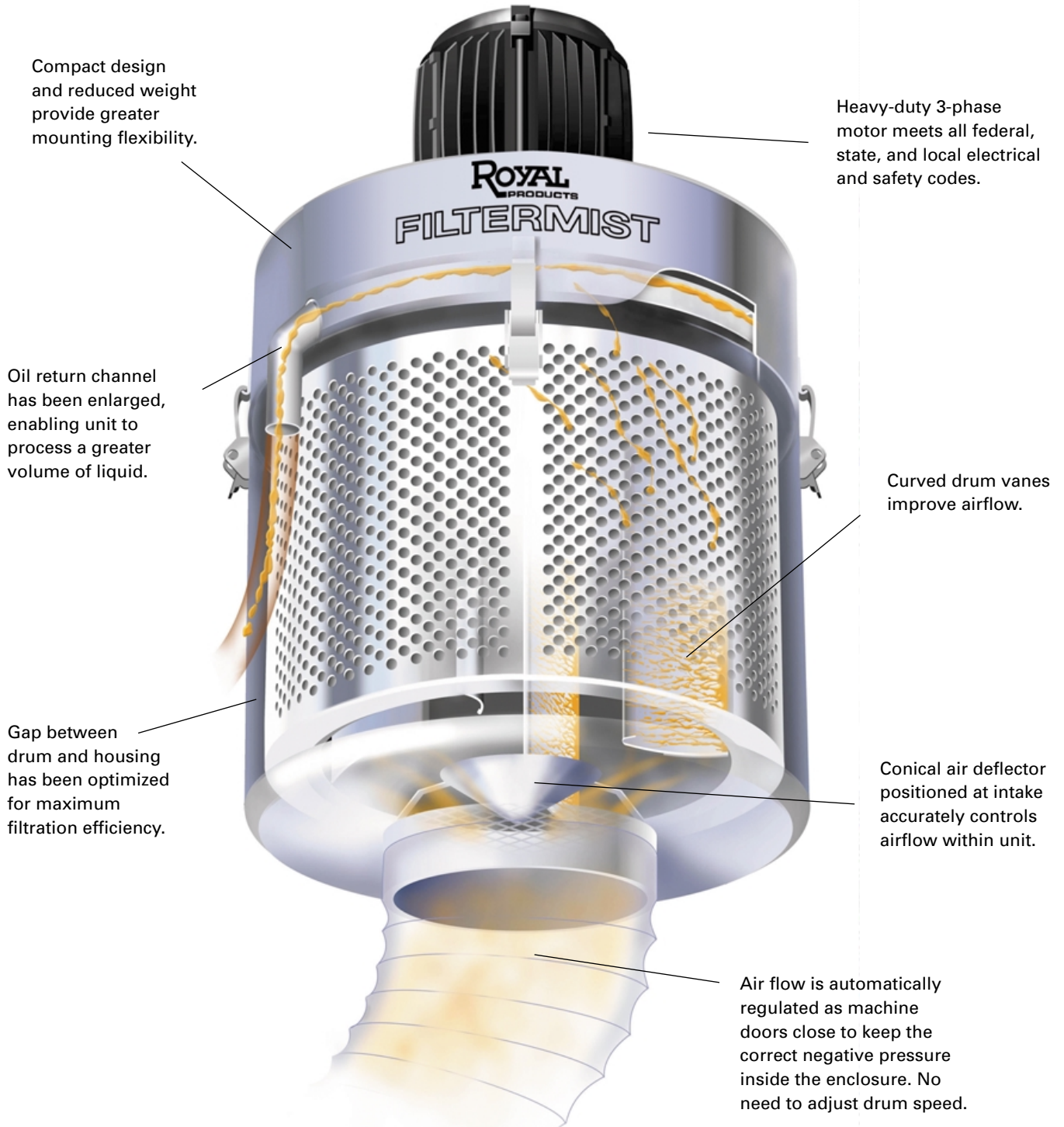

WHY IS THE ROYAL FILTERMIST THE BEST CHOICE FOR THE METALWORKING INDUSTRY?



High Efficiency

The Royal Filtermist maintains a continuous high efficiency through constant drum speed. Performance does not decrease with use. See page 16 for efficiency information.

Low Maintenance

Because the unit works on a mechanical principle instead of electrostatics or multi-stage filters, the Royal Filtermist requires significantly less maintenance than most other filtration systems on the market. The small amount of regular maintenance that is required can be easily performed by the customer. See page 26 for maintenance information.

High Quality

When you purchase a Royal Filtermist, you receive a quality product. Features found on all units include:

- Heavy-duty 3-phase motors that meet all federal, state and local electrical and safety codes.
- All exposed surfaces on the drum and housing are powder coated for wear resistance and long life.
- Very tight manufacturing tolerances provide precise fits between mating parts and ensure that the unit will provide years of trouble-free service.

Vibration Control

The Royal Filtermist incorporates unique features to help it overcome vibration-related problems that are sometimes associated with **other** centrifugal impaction type systems:

- All drums are dynamically balanced at the factory and tested before shipping.
- Vertical drum arrangement provides even mass distribution.
- Motor is connected to housing with four neoprene mounts, effectively isolating vibration and controlling startup torque.

Low Operating Costs

The Royal Filtermist is cost-effective to own and operate. Other types of systems (media, electrostatic, etc.) require frequent maintenance and costly filter replacement. Companies that sell these units often push expensive maintenance contracts that can far exceed the initial purchase price.

No Heat/AC Waste

Processed air is returned to the shop, reducing heating and cooling costs. A/C service calls are also reduced by protecting intake filters from contaminants.

Flexibility

Units are portable and typically service individual machines, allowing machines to be easily moved or replaced. Large central systems are connected to multiple machines by costly and non-flexible ductwork, making relocation difficult.

Modular Design

The Royal Filtermist is a modular system. Accessories such as after filters, dust cyclones, noise attenuators, etc. can be easily added as applications require. See pages 10–11 for information on performance accessories.

Easy To Install

Multiple installation configurations allow the Filtermist to overcome almost any mounting obstacle. See pages 12–13 for mounting details.

Wide Range of Sizes

Four sizes ranging from 275–1200 cfm are available to suit all applications.

Strong Technical Support

A large network of local distributors and factory-trained representatives are strategically located throughout the country to provide quick and accurate on-site technical support.

5-Year Warranty

Every Royal Filtermist unit carries a 5-year warranty against failure due to manufacturing defects. Other brands are only protected for 1–2 years. Please note that our warranty does not include normal wear and tear items such as drum pads, silencers, ductwork, etc. The motor carries a one-year warranty.

Proven Worldwide

There are over 125,000 units currently operating in over 40 countries worldwide, making Filtermist the world leader in metalworking pollution control equipment.



Designed specifically to collect oil mist and smoke produced by metalworking machinery, the Royal Filtermist simply does the best job, over a longer period of time, for the lowest cost.

Still Not Convinced? Try a Unit Risk-Free!

We're so confident that the Royal Filtermist is the best solution for mist and smoke generated by metalworking machinery, we are willing to guarantee its performance. Our guarantee is simple:

Risk-Free Performance Guarantee

Royal Products will issue full credit on any Royal Filtermist unit returned within 45 days of the purchase date if the customer is not completely satisfied with its performance. The following conditions apply:

1. The unit must be sized and installed according to the recommendations of our local factory representative and/or authorized Filtermist distributor.
2. Credit will be issued for the unit, but may not be issued for ductwork, oil return hoses, etc., if they are not in resalable condition.
3. The customer must contact Royal Products for a return goods number (RGA #). This number must appear on all paperwork and packaging of the unit being returned.
4. The returned unit must be securely packaged and arrive at Royal Products in good condition.

So give us a call today at 1-800-645-4174 and let us help solve your mist and smoke problems. You'll be glad you did.

Royal Products offers a number of optional accessories designed to enhance Filtermist performance, particularly in very demanding applications. Please contact one of our engineers at 1-800-645-4174 if you have any questions regarding the use of these performance accessories.

After Filter



After filters are available for all Royal Filtermist models. They can be used in any application where extreme high efficiency is required, and are especially useful for dealing with the following conditions:

- Applications where heavy, dry smoke is generated along with the mist.
- Applications that produce very fine mist particles which may sometimes bypass the impaction process, (jobs that run at very high spindle speeds, high-pressure coolant, etc.).

Important — An after filter should not be used to compensate for blow-thru that could result from improper installation. If you have questions or concerns about your installation, please contact one of our engineers at 1-800-645-4174.

After Filter Advantages

Easy Installation

The Royal after filter simply slides over the Filtermist motor and is secured in place with two toggle clips.

High Efficiency

Adding an after filter to a Royal Filtermist unit will greatly increase efficiency in the sub-micron range. See page 16 for additional information on efficiency.

Noise Reduction

An after filter reduces the noise level of a Filtermist unit by approximately 3 dB.

Long Life

Royal after filters have extended service lives due to their large surface area. They also last longer because the centrifugal impaction process of the Filtermist removes most of the pollutants before they ever reach the filter. Systems that rely entirely on media filters for the filtering process tend to have much shorter service lives.

Full Range

After filters are available for all size Filtermist units. Models are also available for older series units.

Stainless Steel Filtermist Units



- In addition to our standard line of powder-coated units, Royal Products also offers all Filtermist FX Series units in stainless steel versions for special applications.
- Drum, housing, internal hardware, and motor shaft are all manufactured from stainless steel.
- Great for aqueous parts washers where caustic soap could penetrate the paint and erode the steel components.
- Also popular for use in food processing applications such as the collection of oil spray from baking lines.

Cyclonic Swarf Separator

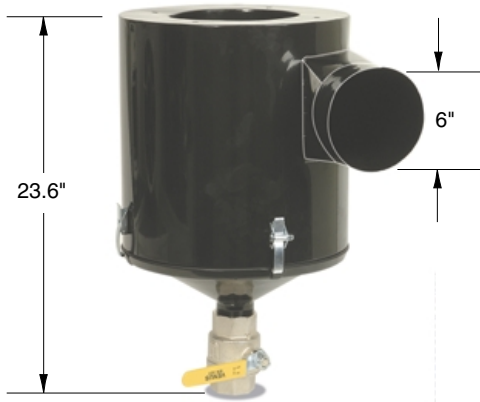

- Recommended for applications that generate solid particles, such as wet grinding dust, cast iron fines, etc.
- Also good for high-speed aluminum milling that produces light fly-away chips.
- Cyclonic action removes solid particles, ensuring that only mist is drawn into the Filtermist unit.
- Acts as a great pre-filter for high pressure coolant applications.
- Reduces maintenance in difficult applications such as heavy grinding.
- Easily attaches to the bottom of the Filtermist unit. Note — the separator cannot be used in direct-mount applications.
- 6" diameter intake port is located on the side of the unit.
- A 2" ball-valve is located on the bottom of the unit for draining.
- Two-piece design allows for easy cleaning.
- Not for use in purely dry applications.
- For models FX-900 and FX-1200 only.
- Reduces throughput of Filtermist unit by approximately 300 cfm.

Chip Deflector

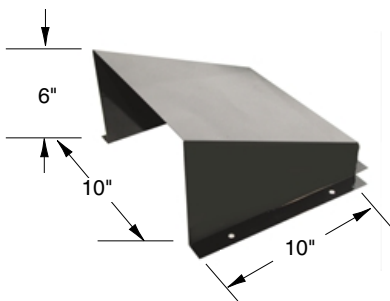

- Protects the Filtermist intake from chips and direct coolant splash.
- Opening is large enough to ensure that airflow and intake velocity are not negatively affected.
- Powder coated finish protects against rust.
- Can be used with all size Filtermist models.
- See page 13 for additional information on correct intake positioning.

Noise Attenuator



- Reduces noise level by 5 dB.
- Easy installation — slips over motor and is secured with toggle clips.
- Cannot be used in conjunction with after filters.
- Excellent for shops with low ceilings.
- Fits models FX-900 and FX-1200.

A wide variety of mounting options makes the Royal Filtermist very easy to install. If you have any questions regarding mounting, please contact one of our applications engineers at 1-800-645-4174.

	FX-275	FX-550	FX-900	FX-1200
Direct Mount	✓	✓	✓	✓
Suspended	-	-	✓	✓
Floor Stand	✓	✓	✓	✓
Machine Top Stand	-	-	✓	✓
Wall Mount	✓	✓	✓	✓
Machine Side Mount	✓	✓	✓*	✓*

* Can be accomplished using either wall bracket or modified floor stand.



Direct Mount

Typically used on enclosed machines such as CNC lathes. All Filtermist models can be mounted this way, but it is important to make sure that the mounting location is well suited to the application and does not interfere with any machine components.



Suspended Mount

Eye bolts included with the FX-900 and FX-1200 enable these units to be suspended from the factory ceiling. Suspension is a low-cost mounting option and is often the best choice for tall machines like large machining centers. Suspension is also a popular choice when a Filtermist unit will be servicing more than one machine.



Floor Stand

Floor stands are available for all models. The stand for models FX-275 and FX-550 is fixed at a height of 6 ft., while the stand for models FX-900 and FX-1200 can be adjusted from 6 ft. – 9 ft. Note that stands must be bolted to the factory floor to prevent tipping.



Machine Top Stand

This 3 ft. high stand enables models FX-900 and FX-1200 to be mounted to the top of a machine, but offers advantages over direct mounting with its small footprint and flexible intake positioning.



Wall Mount

Wall mount brackets are available for all models. Depending upon the machine, it may be possible to use the wall mount bracket to mount a Filtermist to the side of a machine tool.

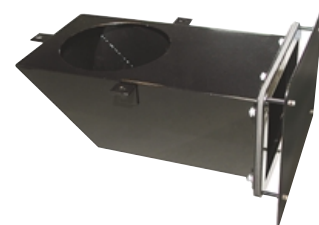

Machine Side Mount

We offer a special side mount bracket for models FX-275 and FX-550 that enables a Filtermist unit to be mounted to the outside wall of a machine tool without the need for any ducting. A built-in deflector protects against chips and coolant splash.

Examples of Various Mounting Arrangements

DIRECT MOUNT

- Unit
- Direct Mounting Kit
- Oil Return Hose

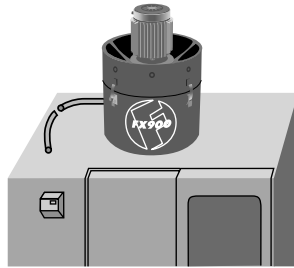

STAND MOUNT

- Unit
- Floor Stand
- Oil Return Hose
- Ducting
- Hose Clamps (2)
- Flange Adapter

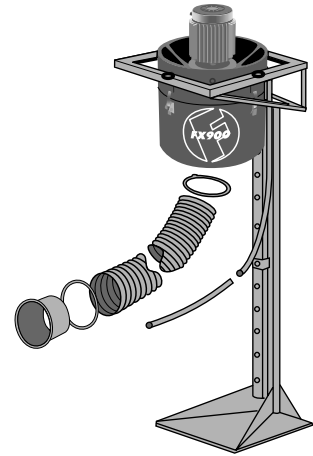

SUSPENDED MOUNT

- Unit
- Suspension Kit
- Oil Return Hose
- Hose Clamps (4)
- Y-Junction
- Ducting
- Fishtails

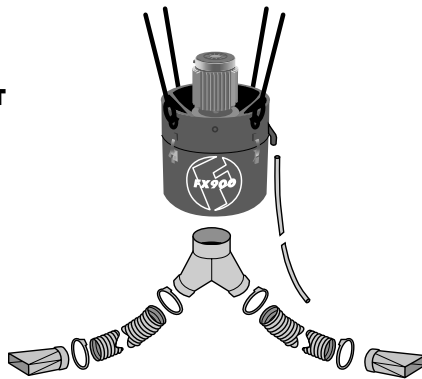

WALL MOUNT

- Unit
- Wall Bracket
- Oil Return Hose
- Hose Clamps (2)
- Ducting
- Flange Adapter

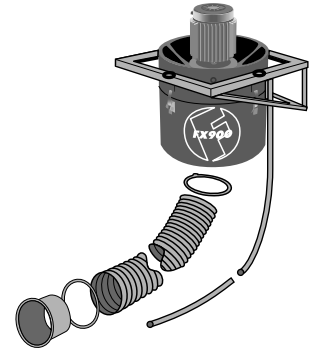

Intake Position — Very Important

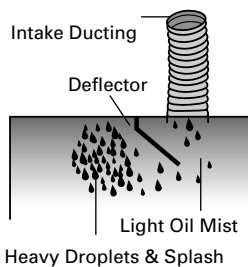

When installing a Filtermist unit, be sure to locate the intake in a position where it will collect mist, not splash. A common mistake is to locate the collection point too close to the cutting action, causing raw coolant and chips to be drawn into the unit. For example, the intake on a CNC lathe should be located near the tailstock-end of the machine, not over the chuck. Whenever possible, draw the mist across the enclosure from an area of heavy concentration to an area of lighter concentration.

For machines where the intake must be positioned near the cutting action, a deflector is often necessary (see page 11). A deflector protects the intake from chips and coolant yet allows mist and smoke to pass around it for collection.

Accessories

Unit	Intake Diameter
FX-275	6"
FX-550	6"
FX-900	6"
FX-1200	8"

Royal Products offers a full array of mounting accessories to simplify installation, including flange adapters, reducers, fishtails, ducting, Y-junctions, etc. Please be sure to keep the correct Filtermist intake diameter in mind when ordering accessories.

Sizing Units

The Royal Filtermist is available in four sizes, based on throughput capacities: 275, 550, 900, and 1200 cfm. Royal Products maintains a database with specifications for many different machine tools, and we recommend you contact one of our applications engineers for your specific sizing requirements.



For those who would like a general rule of thumb, we recommend using the following formula to obtain a rough idea of your requirements:

Filtermist Size = Internal Enclosure Volume x 5

For example, suppose you have a small CNC lathe with an internal work envelope measuring 4ft. wide x 3ft. deep x 4ft. high. Multiplying 4x3x4, we see that the machine has an enclosure volume of 48 cu. ft. Multiplying 48x5 we see that 240 cfm is required, so we'd choose the model FX-275.

Although this rule is very simple, it is handy for determining the general size requirements.

If you are not sure which unit to use, please contact your local Royal Filtermist Distributor or one of our applications engineers.

Grinding



Grinding applications can sometimes be more demanding than typical turning and milling applications because grinding produces fine dust particles that become entrained in the mist stream. Over time, this dust can accumulate on the drum pads, resulting in the need for more frequent maintenance. If regular maintenance is not performed and a significant volume of solid matter builds up in the drum, balance and vibration issues may arise.

A simple way to overcome the problems associated with grinding dust is to fit the Filtermist with a cyclonic swarf separator. The separator mounts below the Filtermist unit and uses cyclonic action to separate out the solid matter, leaving the drum free to process the mist and preventing buildup on the pads. A valve on the bottom of the unit facilitates drainage.

Royal Products recommends using a cyclonic swarf separator for all grinding applications.

Turning



CNC lathes are relatively easy applications to tackle because the machines are usually well enclosed and direct mounting is often possible. On any well enclosed machine, it is recommended that the Filtermist intake point be located as far from the machining action as possible so that the mist is drawn from an area of heavy concentration to an area of lighter concentration. On CNC lathes, therefore, the ideal intake location is on the right side of the machine, near the tailstock. On subspindle lathes where the right-hand wall moves along the z-axis, it might be necessary for the Filtermist to have a more central location.

Milling



For enclosed machining centers, the Filtermist intake position should be located in an upper corner of the enclosure. Installation on open-top machines is not as clear-cut. If enclosing the machine is not possible, a successful installation can often be accomplished by suspending the Filtermist unit above the machine and running ducting down into the enclosure. It may be necessary to adjust the intake location so that it is close enough to the spindle to collect the mist, yet far enough away to keep chips from being drawn in. A Y-junction may be used to draw mist from both sides of the spindle, and a chip deflector may also come in handy.

High-Pressure Coolant

More and more machine tools today are equipped with high-pressure coolant systems. Machines running with high-pressure coolant tend to create more mist, and the particle size also tends to be smaller than normal. For most high-pressure coolant applications, the standard rules apply and Filtermist works very well. However, in some unique situations it may be necessary to take a different approach. Here are two ideas that may be worth considering:

- Downsize the Filtermist unit. On many high-pressure applications, we have seen the smaller models FX-275 and FX-550 work extremely well on large machines that would normally require a model FX-1200. Before downsizing, please speak to one of our applications engineers to ensure that this approach is the best one for your application.
- Add a cyclonic swarf separator. Although this device was designed for removing solid particles from the mist stream, it has proven itself to be quite adept as a pre-filter for high-pressure coolant applications. A large portion of the mist is actually removed by the cyclone, leaving the balance to be easily handled by the Filtermist unit.

Please keep in mind that the ideas presented in this section are simply suggestions, and may not be appropriate for your particular situation. If you have any questions regarding a Filtermist application, please contact one of our engineers at 1-800-645-4174 for assistance.

When evaluating the effectiveness of any mist collection system, two major aspects must be considered:

- The unit must be capable of handling the full volume of mist produced by the application.
- The unit must be efficient at capturing particles of all sizes.

Independent testing has proven the Royal Filtermist FX Series to be very effective at handling large volumes of mist and highly efficient at dealing with the full spectrum of particle sizes found in typical metalworking mist concentrations.

While a typical metalworking mist concentration is made up of many different-sized particles, 80–90% of these particles are larger than one micron in size. Fewer than 10% of the particles are smaller than 0.5 micron in size.

In order to effectively eliminate mist, the Royal Filtermist incorporates a two-phase process:

1. The first phase utilizes the mechanical process of centrifugal impaction. This centrifugal impaction process is the heart of the Filtermist’s operating principle and it is highly effective at handling large volumes of mist.

The centrifugal impaction process is almost 100% efficient at handling particles larger than one micron, which make up the bulk of the mist. When considering a weighted average of the particle size in a typical metalworking mist concentration, overall efficiency of the impaction process is roughly 98%.

2. Many may consider an efficiency of 98% to be adequate for their needs. However, if additional efficiency is required, the Royal Filtermist FX Series units may be equipped with an after filter to handle the small amount of residual mist that bypasses the impaction process. Royal after filters use a carefully selected grade of media that provides an effective balance between being fine enough to capture the smallest of particles while still allowing the filter to enjoy a comparatively long service life. **Overall efficiency of a Royal Filtermist FX Series unit equipped with an after filter exceeds 99.5%.**

OSHA and NIOSH Standards

The OSHA and NIOSH limits on airborne mist particles are currently set at 5mg/m³. It is believed that in the coming years this level will be reduced by a factor of ten to a new level of 0.5 mg/m³. The Royal Filtermist FX is so efficient that when equipped with an after filter, it easily meets not only the current limit, but even the stricter proposed limit.

Location	Concentration (mg / m ³)
Ambient Shop Air	0.75
FX-1200 Inlet	8.0 – 10.0
FX-1200 Exhaust	0.18

In a recent test carried out by an independent contractor, a Mori Seiki SL75ML was fitted with a model FX-1200 Filtermist unit and after filter. Particle counters were set up to monitor the air at three locations during machining — the ambient shop air, the Filtermist intake, and the Filtermist exhaust. The test results confirm that the Filtermist easily meets the challenge. Particle concentration levels at the Filtermist exhaust were well below 0.5 mg/m³. In fact, the air at the Filtermist exhaust was four-times cleaner than the ambient shop air!

IMPORTANT — The Royal Filtermist is designed to help your shop meet current and future air quality standards. It must be understood, however, that there are many variables involved in controlling shop pollution and we cannot guarantee that the Filtermist alone will prevent occupational diseases to workers. It is your responsibility to establish an effective overall industrial hygiene program designed to comply with OSHA and NIOSH standards. If you have any questions regarding this issue, please contact us at 1-800-645-4174.

How do I select the correct Royal Filtermist for my application?

Page 14 of this catalog contains some basic sizing information, and you are always welcome to speak to one of our engineers at 1-800-645-4174 if you have any questions. We can also arrange to have one of our local representatives visit your factory to check out your application and make the appropriate recommendations.

How do I order?

The Royal Filtermist system is sold in the U.S. through an exclusive network of authorized distributors. To find out who your local Royal Filtermist distributor is, please contact our customer service department at 1-800-645-4174.

How do Filtermist units ship?

All Filtermist FX Series units can be shipped via UPS. Due to dimensional limitations, the floor stand must ship by truck. When ordering multiple units, it is often more cost effective to ship by truck.



How do I install the Royal Filtermist in my shop?

The Royal Filtermist is a relatively easy piece of equipment to install, and most shops handle their own installations. Detailed instructions are included with each unit.

To ensure a smooth installation process, be sure you have ordered all of the necessary mounting and performance accessories. We recommend using the handy checklist featured on page 29. Please note that all accessories offered in this catalog have been tested for performance and safety. Substituting accessories with non-Royal items could void the Filtermist warranty, affect performance, and result in dangerous operating conditions.

What about wiring?



The three-phase Filtermist motor must be wired in conjunction with a manual starter, which is not supplied by Royal Products. The recommended heater size is 1.25 times the rated motor amperage, based upon your plant's operating voltage. We suggest you have a licensed electrician perform the wiring of the unit. Detailed instructions can be found in the installation manual that is supplied with each unit.

Can the drum pads be cleaned?

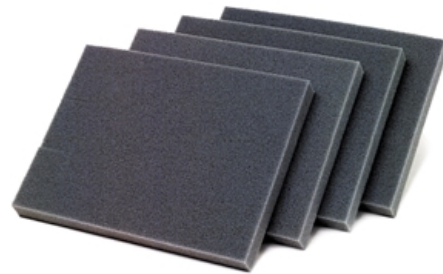

The pads that line the Filtermist drum are made from a specially manufactured foam containing thousands of tiny pores. These pores provide direct pathways from one side of the pad to the other for optimum airflow. They also assist in the coalescence of the mist particles for improved fluid collection.

It is important that the pores of the drum pads be kept open for maximum flow, so periodic replacement is advised. Washing the drum pads is not recommended because the pores are difficult to clean effectively. Signs that the drum pads should be replaced include a reduction in airflow and/or vibration due to buildup of solid matter.

What happens if I have a problem?

In addition to our large network of authorized distributors, Royal Products employs over 50 factory-trained representatives located throughout the country. In the event of a problem that cannot be solved over the phone, we will arrange for a local Royal Products representative to visit your factory and work with you towards a solution. We firmly believe that after-sales support is as important as the sale itself, and we are committed to this effort.



FX-275 Specifications

Airflow	275 cfm
Fits machines with enclosure volume of:	Up to 80 cubic feet
Motor	3/4 HP, 3-Phase, 50/60 Hz. Voltage & Current @ 60Hz: 208V – 2.7A 230V – 2.5A 460V – 1.3A
Weight	31 lbs.
Noise Level	65 dBA
Inlet Diameter	6"

Mounting Options — FX-275

Direct Mount	Hardware included with Filtermist Unit
Floor Stand	use 30316 — Floor Stand "A"
Machine Top Stand	N/A
Wall Mount	use 30328 — Wall Bracket "A"
Machine Side Mount	use 30330 — Side-Mount Bracket "A"
Suspended	N/A

- Used primarily on small, enclosed CNC machines with an internal volume of up to 80 cu. ft.
- Large 6" dia. intake results in a very low intake velocity, reducing the likelihood that chips and large droplets will be drawn into the unit.
- The model FX-275 comes complete with a collar seal, mounting hardware, and 5 ft. of oil return hose.
- Designed primarily for direct-mounting to the top of a machine, but stands and brackets are also available for applications where direct-mounting is not possible.
- Stainless steel model available for special applications.

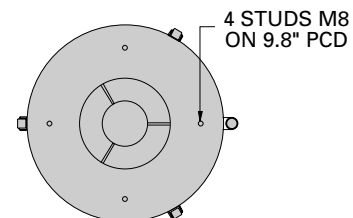
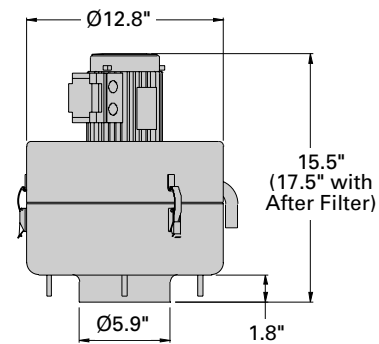



Filtermist Units

Description	Cat. No.	Price
FX-275 Filtermist Unit Includes collar seal and all necessary hardware to mount unit directly to the top of a machine. Also includes 5 ft. of oil return hose.	30100	\$1,485
FX-275 Stainless Steel Unit See page 10 for additional information.	30140	\$ 2,925

Performance Accessories

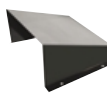
Description	Cat. No.	Price
 After Filter "A" Used for collecting dry smoke and very fine mist particles.	30200	\$ 218
 Chip Deflector Protects intake from coolant splash and chips.	30220	\$ 44

Mounting Accessories

Description	Cat. No.	Price																		
 Side Mounting Bracket "A" Allows unit to be mounted to the side of a machine tool. Includes hardware and chip deflector.	30330	\$ 285																		
 Floor Stand "A" Fixed height of 6 ft. Bolts to floor for safety.	30316	\$423																		
 Wall Bracket "A" For mounting unit to a wall or side of a machine.	30328	\$ 221																		
 Oil Return Hose 3/4" diameter.	30335	\$3 per ft.																		
 Ducting Flexible vinyl 8" with heavy wire support.	8" 30344 6" 30342 4" 30340	\$11 per ft. \$9 per ft. \$8 per ft.																		
Warning — never use sheetmetal ducting or any other type that could leak and cause a hazardous condition.																				
 Hose Clamps For securing ducting to accessories.	8" 30354 6" 30352 4" 30350	\$5 \$5 \$4																		
 Y-Junctions For multiple pickup locations.	<table border="0"> <tr> <td>A</td> <td>B</td> <td></td> </tr> <tr> <td>8"</td> <td>6"</td> <td>30368</td> </tr> <tr> <td>8"</td> <td>4"</td> <td>30366</td> </tr> <tr> <td>6"</td> <td>6"</td> <td>30364</td> </tr> <tr> <td>6"</td> <td>4"</td> <td>30362</td> </tr> <tr> <td>4"</td> <td>4"</td> <td>30360</td> </tr> </table>	A	B		8"	6"	30368	8"	4"	30366	6"	6"	30364	6"	4"	30362	4"	4"	30360	\$231 \$283 \$213 \$203 \$168
A	B																			
8"	6"	30368																		
8"	4"	30366																		
6"	6"	30364																		
6"	4"	30362																		
4"	4"	30360																		
 Flange Adapters For securing ducting directly to an enclosed machine.	8" 30374 6" 30372 4" 30370	\$61 \$56 \$49																		
 Reducers	<table border="0"> <tr> <td>A</td> <td>B</td> <td></td> </tr> <tr> <td>8"</td> <td>6"</td> <td>30382</td> </tr> <tr> <td>6"</td> <td>4"</td> <td>30380</td> </tr> </table>	A	B		8"	6"	30382	6"	4"	30380	\$93 \$88									
A	B																			
8"	6"	30382																		
6"	4"	30380																		
 Fishtails For use on open machines.	<table border="0"> <tr> <td>A</td> <td>B</td> <td></td> </tr> <tr> <td>8"</td> <td>11.75" x 5"</td> <td>30394</td> </tr> <tr> <td>6"</td> <td>10" x 4.5"</td> <td>30392</td> </tr> <tr> <td>4"</td> <td>8.25" x 3.5"</td> <td>30390</td> </tr> </table>	A	B		8"	11.75" x 5"	30394	6"	10" x 4.5"	30392	4"	8.25" x 3.5"	30390	\$167 \$149 \$137						
A	B																			
8"	11.75" x 5"	30394																		
6"	10" x 4.5"	30392																		
4"	8.25" x 3.5"	30390																		



FX-550 Specifications

Airflow	550 cfm
Fits machines with enclosure volume of:	60–120 cubic feet
Motor	3/4 HP, 3-Phase, 50/60 Hz. Voltage & Current @ 60Hz. 208V – 2.7A 230V – 2.5A 460V – 1.3A
Weight	35 lbs.
Noise Level	67 dBA
Inlet Diameter	6"

Mounting Options — FX-550

Direct Mount	Hardware included with Filtermist Unit
Floor Stand	use 30316 — Floor Stand "A"
Machine Top Stand	N/A
Wall Mount	use 30328 — Wall Bracket "A"
Machine Side Mount	use 30330 — Side-Mount Bracket "A"
Suspended	N/A

- Replaces model FX-600.
- For use on enclosed machines with an internal volume between 60 cu. ft. and 120 cu. ft.
- Well suited to many swiss-style CNC's and screw machines.
- Designed primarily for direct-mounting to the top of a machine, but stands and brackets are also available for applications where direct-mounting is not possible.
- Stainless steel model available for special applications.

NEW

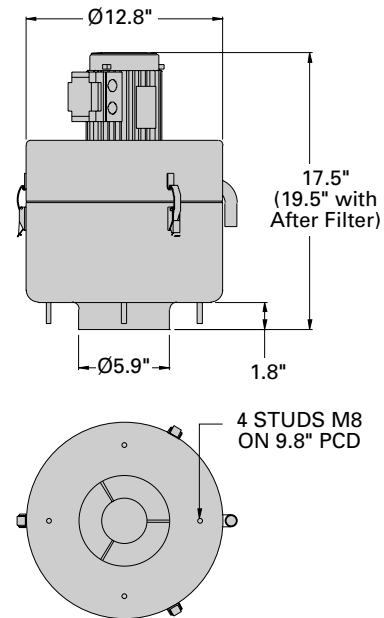







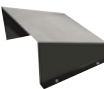

Filtermist Units

Description	Cat. No.	Price
FX-550 Filtermist Unit Includes collar seal and all necessary hardware to mount unit directly to the top of a machine. Also includes 5 ft. of oil return hose.	30108	\$1,845
FX-550 Stainless Steel Unit See page 10 for additional information.	30180	\$3,250

Performance Accessories

Description	Cat. No.	Price
 After Filter "A" Used for collecting dry smoke and very fine mist particles.	30200	\$218
 Chip Deflector Protects intake from coolant splash and chips.	30220	\$44

Mounting Accessories

Description	Cat. No.	Price
 Side Mounting Bracket "A" Allows unit to be mounted to the side of a machine tool. Includes hardware and chip deflector.	30330	\$285
 Floor Stand "A" Fixed height of 6 ft. Bolts to floor for safety.	30316	\$423
 Wall Bracket "A" For mounting unit to a wall or side of a machine.	30328	\$221
 Oil Return Hose 3/4" diameter.	30335	\$3 per ft.
Ducting Flexible vinyl 8" with heavy wire 6" support. 4"	30344 30342 30340	\$11 per ft. \$9 per ft. \$8 per ft.
Warning — never use sheetmetal ducting or any other type that could leak and cause a hazardous condition.		
 Hose Clamps For securing ducting to accessories.	8" 6" 4"	30354 \$5 30352 \$5 30350 \$4
 Y-Junctions For multiple pickup locations.	A B 8" 6" 8" 4" 6" 6" 6" 4" 4" 4"	30368 \$231 30366 \$283 30364 \$213 30362 \$203 30360 \$168
 Flange Adapters For securing ducting directly to an enclosed machine.	8" 6" 4"	30374 \$61 30372 \$56 30370 \$49
 Reducers	A B 8" 6" 6" 4"	30382 \$93 30380 \$88
 Fishtails For use on open machines.	A B 8" 11.75" x 5" 6" 10" x 4.5" 4" 8.25" x 3.5"	30394 \$167 30392 \$149 30390 \$137



FX-900 Specifications

Airflow	900 cfm
Fits machines with enclosure volume of:	90–180 cubic feet
Motor	3 HP, 3-Phase, 50/60 Hz. Voltage & Current @ 60Hz. 208V – 8.8A 230V – 8.2A 460V – 4.1A
Weight	51 lbs.
Noise Level	70 dBA
Inlet Diameter	6"

Mounting Options — FX-900

Direct Mount	use 30302 — FX-900 Direct Mount Kit
Floor Stand	use 30315 — Floor Stand "B"
Machine Top Stand	use 30314 — Machine Stand "B"
Wall Mount	use 30320 — Wall Bracket "B"
Machine Side Mount	N/A
Suspended	use 30310 — Suspension Kit "B"

- For use on enclosed machines with an internal volume between 90 cu. ft. and 180 cu. ft.
- Popular for open machines requiring a Y-junction and two intake points.
- Unit can be mounted directly to the machine, on stands, on brackets, or suspended. See pages 12-13 for mounting options.

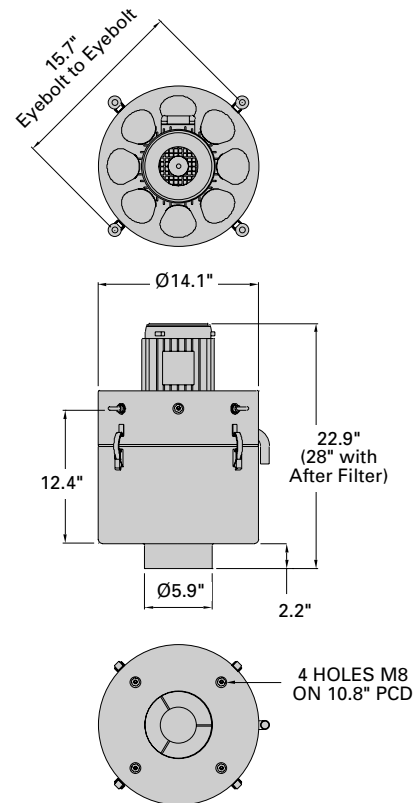











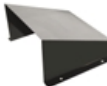



Filtermist Units

Description	Cat. No.	Price
FX-900 Filtermist Unit Order performance and mounting accessories separately.	30120	\$2,285
FX-900 Stainless Steel Unit See page 10 for additional information.	30160	\$3,715

Performance Accessories

Description	Cat. No.	Price
 After Filter "B" Used for collecting dry smoke and very fine mist particles.	30205	\$234
 Cyclonic Swarf Separator For use on applications such as grinding and cast iron machining where very fine solid particles are entrained in the mist stream. Also acts as a great pre-filter for high pressure coolant applications.	30210	\$643
 Noise Attenuator Decreases the noise level by approximately 5 dB. Cannot be used in conjunction with after filters.	30215	\$483
 Chip Deflector Protects intake from coolant splash and chips.	30220	\$44

Mounting Accessories

Description	Cat. No.	Price
 Direct Mount Kit (FX-900) Includes 6" collar seal, set of rigid mounting studs, and hardware.	30302	\$86
 Floor Stand "B" Adjusts from 6 ft. to 9 ft. Bolts to floor for safety.	30315	\$719
 Machine Top Stand "B" 3 ft. tall stand bolts to the top of a machine.	30314	\$453
 Wall Bracket "B" Can be used to mount unit to a wall or other suitable mounting surface.	30320	\$279
 Suspension Kit "B" Includes 30 ft. of chain, 4 eyebolts, 8 split links, and 1 adjustable link.	30310	\$98
 Oil Return Hose 3/4" diameter.	30335	\$3 per ft.
Ducting Flexible vinyl with heavy wire support.	8" 30344 6" 30342 4" 30340	\$11 per ft. \$9 per ft. \$8 per ft.
Warning — never use sheetmetal ducting or any other type that could leak and cause a hazardous condition.		
 Hose Clamps For securing ducting to accessories.	8" 30354 6" 30352 4" 30350	\$5 \$5 \$4
 Y-Junctions For multiple pickup locations.	A B 8" 6" 30368 8" 4" 30366 6" 6" 30364 6" 4" 30362 4" 4" 30360	\$231 \$283 \$213 \$203 \$168
 Flange Adapters For securing ducting directly to an enclosed machine.	8" 30374 6" 30372 4" 30370	\$61 \$56 \$49
 Reducers	A B 8" 6" 30382 6" 4" 30380	\$93 \$88
 Fishtails For use on open machines.	A B 8" 11.75" x 5" 30394 6" 10" x 4.5" 30392 4" 8.25" x 3.5" 30390	\$167 \$149 \$137



FX-1200 Specifications

Airflow	1200 cfm
Fits machines with enclosure volume of:	120 cubic feet or larger
Motor	3 HP, 3-Phase, 50/60 Hz. Voltage & Current @ 60Hz. 208V – 8.8A 230V – 8.2A 460V – 4.1A
Weight	64 lbs.
Noise Level	72 dBA
Inlet Diameter	8"

Mounting Options — FX-1200

Direct Mount	use 30304 — FX-1200 Direct Mount Kit
Floor Stand	use 30315 — Floor Stand "B"
Machine Top Stand	use 30314 — Machine Stand "B"
Wall Mount	use 30320 — Wall Bracket "B"
Machine Side Mount	N/A
Suspended	use 30310 — Suspension Kit "B"

- For use on enclosed machines with an internal volume of 120 cu. ft. or larger.
- Popular for machines requiring Y-junction and two intake points.
- Excellent choice for large machining centers.
- Unit can be mounted directly to the machine, on stands, on brackets, or suspended. See pages 12–13 for mounting options.

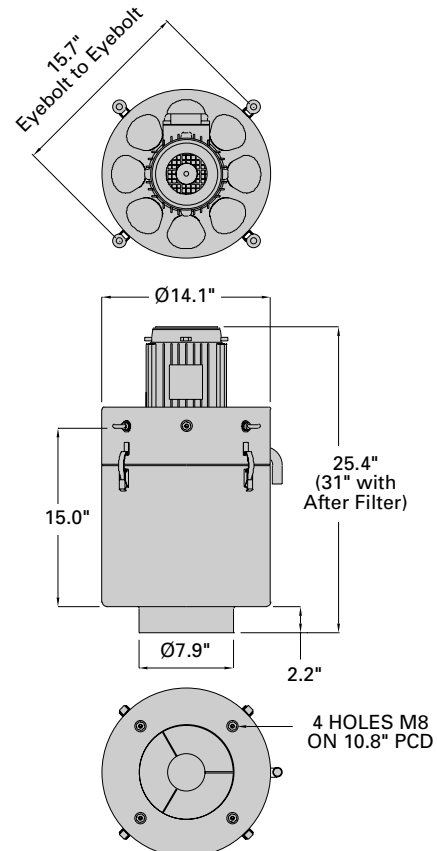









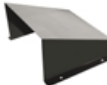



Filtermist Units

Description	Cat. No.	Price
FX-1200 Filtermist Unit Order performance and mounting accessories separately.	30130	\$2,395
FX-1200 Stainless Steel Unit See page 10 for additional information.	30170	\$4,065

Performance Accessories

Description	Cat. No.	Price
 After Filter "B" Used for collecting dry smoke and very fine mist particles.	30205	\$234
 Cyclonic Swarf Separator For use on applications such as grinding and cast iron machining where very fine solid particles are entrained in the mist stream. Also acts as a great pre-filter for high pressure coolant applications.	30210	\$643
 Noise Attenuator Decreases the noise level by approximately 5 dB. Cannot be used in conjunction with after filters.	30215	\$483
 Chip Deflector Protects intake from coolant splash and chips.	30220	\$44

Mounting Accessories

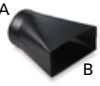
Description	Cat. No.	Price
 Direct Mount Kit (FX-1200) Includes 8" collar seal, set of rigid mounting studs, and hardware.	30304	\$97
 Floor Stand "B" Adjusts from 6 ft. to 9 ft. Bolts to floor for safety.	30315	\$719
 Machine Top Stand "B" 3 ft. tall stand bolts to the top of a machine.	30314	\$453
 Wall Bracket "B" Can be used to mount unit to a wall or other suitable mounting surface.	30320	\$279
 Suspension Kit "B" Includes 30 ft. of chain, 4 eyebolts, 8 split links, and 1 adjustable link.	30310	\$98
 Oil Return Hose 3/4" diameter.	30335	\$3 per ft.
Ducting Flexible vinyl with heavy wire support.	8" 30344 6" 30342 4" 30340	\$11 per ft. \$9 per ft. \$8 per ft.
Warning — never use sheetmetal ducting or any other type that could leak and cause a hazardous condition.		
 Hose Clamps For securing ducting to accessories.	8" 30354 6" 30352 4" 30350	\$5 \$5 \$4
 Y-Junctions For multiple pickup locations.	A B 8" 6" 30368 8" 4" 30366 6" 6" 30364 6" 4" 30362 4" 4" 30360	\$231 \$283 \$213 \$203 \$168
 Flange Adapters For securing ducting directly to an enclosed machine.	8" 30374 6" 30372 4" 30370	\$61 \$56 \$49
 Reducers	A B 8" 6" 30382 6" 4" 30380	\$93 \$88
 Fishtails For use on open machines.	A B 8" 11.75" x 5" 30394 6" 10" x 4.5" 30392 4" 8.25" x 3.5" 30390	\$167 \$149 \$137

FILTERMIST MAINTENANCE



One of the most popular features of the Royal Filtermist is the fact that it requires minimal maintenance. Unlike media-type systems and electrostatic units, the Royal Filtermist works almost as well when it is dirty as it does when it is clean.



For safety purposes, it is necessary to periodically inspect the main components of the Royal Filtermist for wear or damage, especially if the unit is making loud noises or exhibiting vibration. Additionally, we recommend that these simple maintenance procedures be carried out every 2,000 operating hours, (every 1,000 hours for more demanding applications):

- Replace the drum pads. The pads that line the Filtermist drum are made from a specially manufactured foam containing thousands of tiny pores. These pores provide direct pathways from one side of the pad to the other for optimum airflow. They also assist in the coalescence of the mist particles for improved fluid collection. It is important that the pores of the drum pads be kept open for maximum flow.
- Inspect and replace the motor mounts and torque limiting straps if worn or damaged.
- Inspect silencer and replace if worn or damaged. If the silencer is saturated with oil, it is important to investigate the reason why. This could be the result of a clogged oil return channel or incorrect drum rotation. Important — the Filtermist will create suction regardless of which way the drum spins, but it will only properly collect and return oil mist if the drum is spinning in the proper direction as indicated by the arrow on the housing.
- Inspect the housing seal and replace if necessary. This is especially important on older series units. The redesigned housing of the Filtermist FX Series virtually eliminates the chance of leakage around the seal area.
- Check all mounting fixtures such as stands and suspension kits for damage or signs of fatigue. Repair or replace as necessary.
- Check all other accessories for wear and/or damage (ducting, flange adapters, etc.). Repair or replace as necessary.
- For your convenience, Royal Products offers complete maintenance kits for all Filtermist units. These value-priced kits include a drum pad set, a motor mount set, a silencer, and a housing seal. These items are also available separately.

Important — The recommended maintenance schedule and procedures outlined above are meant to serve as a guide for most common Filtermist applications. More detailed information is provided in the Royal Filtermist Installation and Maintenance Manual. When dealing with any equipment of this type, common sense must prevail. Any unsafe conditions pertaining to the Royal Filtermist must be immediately attended to. It is also important to understand that when Royal Filtermist units are used in demanding applications such as grinding or cast iron machining, more frequent maintenance may be required. If you have any questions regarding the maintenance or operation of your Royal Filtermist units, please refer to the Royal Filtermist Installation and Maintenance Manual or contact one of our engineers at 1-800-645-4174.

Maintenance Items

Description	FX-275		FX-550		FX-900		FX-1200	
	Cat. No.	Price	Cat. No.	Price	Cat. No.	Price	Cat. No.	Price
Complete Maintenance Kit Complete kit provides a cost savings over individual components. Includes the following: drum pad set, silencer, housing seal, and motor mount set.	30400	\$110	30406	\$129	30402	\$158	30404	\$167
Drum Pad Set	30410	\$26	30416	\$41	30412	\$49	30414	\$55
Silencer	30420	\$60	30420	\$60	30422	\$98	30422	\$98
Housing Seal	30430	\$12	30430	\$12	30432	\$15	30432	\$15
Motor Mount Set	30440	\$44	30440	\$44	30442	\$51	30442	\$51

See page 28 for maintenance items for older series Filtermist units.



Serial Number Label

Royal Products offers a full array of replacement parts for all Filtermist models. When ordering replacement parts, it is very important that you identify the correct series and model. The series is determined by the color of the serial number label, located on the upper portion of the housing near the motor. The color code is as follows:

- Series 6 — Black label, silver text.
- Series 7 — Yellow label, black text.
- Series 8 — White label, black text.
- FX Series — Blue label, white text.

On this unit, the white label with the black text indicates a series 8 model.

FX Series Only

Item No.	Description	Filtermist Model	Blue Label (FX Series)
1	Motor	FX-275	30450
		FX-550	30450
		FX-600	30452
		FX-900	30454
		FX-1200	30454
2	Motor Mount Set Includes four mounts and required hardware.	FX-275	30440
		FX-550	30440
		FX-600	30442
		FX-900	30442
		FX-1200	30442
3	Silencer	FX-275	30420
		FX-550	30420
		FX-600	30422
		FX-900	30422
		FX-1200	30422
4	Drum	FX-275	30460
		FX-550	30466
		FX-600	30462
		FX-900	30462
		FX-1200	30464
5	Drum Pads (set of 4)	FX-275	30410
		FX-550	30416
		FX-600	30412
		FX-900	30412
		FX-1200	30414
6	Housing Seal	FX-275	30430
		FX-550	30430
		FX-600	30432
		FX-900	30432
		FX-1200	30432
7	Direct Mounting Kit Includes collar seal, mounts, and required hardware.	FX-275	N/A
		FX-550	N/A
		FX-600	30300
		FX-900	30302
		FX-1200	30304
8	Complete Maintenance Kit Includes items 2, 3, 5 and 6.	FX-275	30400
		FX-550	30406
		FX-600	30402
		FX-900	30402
		FX-1200	30404
9	Complete After Filter Fits over the Filtermist motor. Includes 1-pc. housing/filter element, and toggle clips.	FX-275	30200
		FX-550	30200
		FX-600	30205
		FX-900	30205
		FX-1200	30205

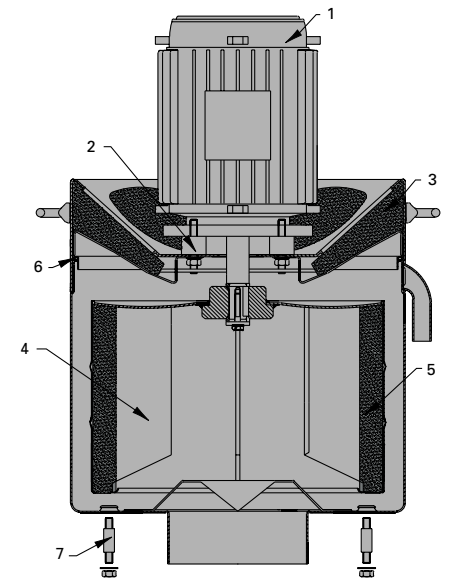
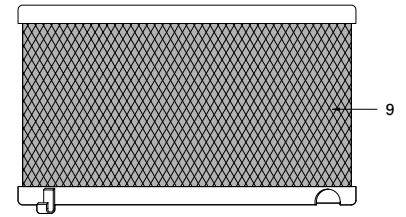

Note — The parts on this page are for Filtermist FX Series models with a blue serial number label. If you have an older model Filtermist unit with a white, yellow, or black serial number label, please see page 28.

For all other replacement parts, please contact us at 1-800-645-4174.

Series 6, 7, and 8 (Pre-2004)

Item No.	Description	Filtermist Model	White Label (Series 8)	Yellow Label (Series 7)	Black Label (Series 6)
1	Motor	F-275 F-600 F-900 F-1200	R33-1439-926 R35L234-672 R35L234-863 R35L234-863	R33-1439-926 R35L234-672 R35L234-863 N/A	R33-1439-926 R35L234-672 R35L234-863 N/A
2	Motor Mount Set Includes four mounts and required hardware.	F-275 F-600 F-900 F-1200	28195 28198 28198 28198	28195 28198 28198 N/A	28195 28198 28198 N/A
3	Silencer	F-275 F-600 F-900 F-1200	28182 28181N 28181N 28181N	28182 28181N 28181N N/A	28182 28181 28181 N/A
4	Drum	F-275 F-600 F-900 F-1200	28013 28167 28167 28166	28013 28167 28166 N/A	28013 28167 28166 N/A
5	Drum Pads (set of 4)	F-275 F-600 F-900 F-1200	28214 28209 28209 28207	28214 28212 28210 N/A	28214 28212 28210 N/A
6	Housing Seal	F-275 F-600 F-900 F-1200	28176 28178N 28178N 28178N	28176 28178N 28178N N/A	28179 28178 28178 N/A
7	Direct Mounting Kit Includes collar seal, mounts, and required hardware.	F-275 F-600 F-900 F-1200	N/A 28205 28203 28201	28194 28203 28203 N/A	28194 28203 28203 N/A
8	Complete Maintenance Kit Includes items 2, 3, 5 and 6.	F-275 F-600 F-900 F-1200	28008 28015 28015 28017	28008 28007 28006 N/A	N/A N/A N/A N/A
9	Complete After Filter Fits over the Filtermist motor. Includes housing, filter element, and toggle clips.	F-275 F-600 F-900 F-1200	28158 28164 28164 28164	28158 28164 28164 N/A	28158 28164 28164 N/A
10	After Filter — Replacement Element Only	F-275 F-600 F-900 F-1200	28159 28165 28165 28165	28159 28165 28165 N/A	28159 28165 28165 N/A
11	Drum Puller	All Units	28014	28014	28014

For all other replacement parts, please contact us at 1-800-645-4174.

Note — The parts on this page are for older series Filtermist units sold thru mid 2004. See page 27 for Filtermist FX Series components.

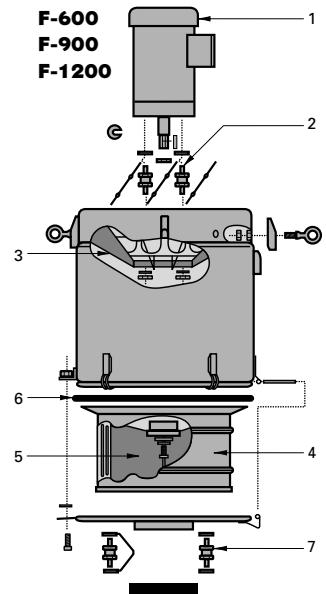
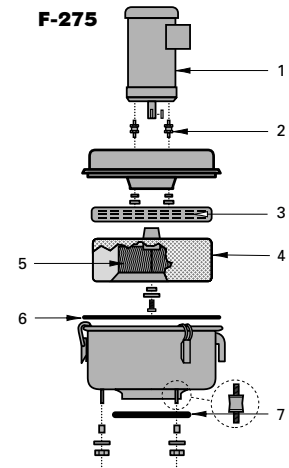
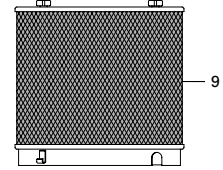
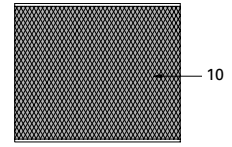

When placing a Filtermist order, please use this sheet to help our engineers verify that you have selected the correct Filtermist unit and accessories for your particular application.

Company: _____ Contact Name: _____

Tel: _____ Fax: _____

Machine Make and Model: _____

Internal Volume of Machine Enclosure (see page 14 for sizing information): _____
 (LxWxH) Example 5x3.5x4=70 cu. ft.

Filtermist Units	Cat. No.	Qty.	List Price
FX-275	30100		\$1,485
FX-550	30108		\$1,845
FX-900	30120		\$2,285
FX-1200	30130		\$2,395
FX-275 Stainless Steel	30140		\$2,925
FX-550 Stainless Steel	30180		\$3,250
FX-900 Stainless Steel	30160		\$3,715
FX-1200 Stainless Steel	30170		\$4,065

Performance Accessories	Cat. No.	Qty.	List Price
After Filter "A" (FX-275 & 550)	30200		\$218
After Filter "B" (FX-900 & 1200)	30205		\$234
Cyclonic Swarf Separator (FX-900 & 1200)	30210		\$643
Noise Attenuator (FX-900 & 1200)	30215		\$483
Chip Deflector (All models)	30220		\$44

Maintenance Items	Cat. No.	Qty.	List Price
Complete Maintenance Kit (FX-275)	30400		\$110
Complete Maintenance Kit (FX-550)	30406		\$129
Complete Maintenance Kit (FX-900)	30402		\$158
Complete Maintenance Kit (FX-1200)	30404		\$167

Mounting Accessories	Cat. No.	Qty.	List Price
Direct Mount Kit (FX-900)	30302		\$86
Direct Mount Kit (FX-1200)	30304		\$97
Suspension Kit "B"	30310		\$98
Floor Stand "A" (FX-275 & 550)	30316		\$423
Floor Stand "B" (FX-900 & 1200)	30315		\$719
Wall Bracket "A" (FX-275 & 550)	30328		\$221
Wall Bracket "B" (FX-900 & 1200)	30320		\$279
Machine Top Stand "B" (FX-900 & 1200)	30314		\$453
Side Mount Bracket "A" (FX-275 & 550)	30330		\$285
Oil Return Hose	30335		\$3 per ft.
Ducting (4")	30340		\$8 per ft.
Ducting (6")	30342		\$9 per ft.
Ducting (8")	30344		\$11 per ft.
Hose Clamp (4")	30350		\$4
Hose Clamp (6")	30352		\$5
Hose Clamp (8")	30354		\$5
Y-Junction (4x4x4)	30360		\$168
Y-Junction (6x4x4)	30362		\$203
Y-Junction (6x6x6)	30364		\$213
Y-Junction (8x4x4)	30366		\$283
Y-Junction (8x6x6)	30368		\$231
Flange Adapter (4")	30370		\$49
Flange Adapter (6")	30372		\$56
Flange Adapter (8")	30374		\$61
Reducer (6x4)	30380		\$88
Reducer (8x6)	30382		\$93
Fishtail (4")	30390		\$137
Fishtail (6")	30392		\$149
Fishtail (8")	30394		\$167

ROYAL FILTERMIST FX Series

Catalog and Price List



**Low Cost, Highly Efficient Mist
and Smoke Collectors Designed
Specifically for the
Metalworking Industry**



Division of Curran Manufacturing Corporation

200 Oser Avenue
Hauppauge, New York 11788

Tel: 1-631-273-1010
Fax: 1-631-273-1066

Toll-Free USA and Canada
Tel: 1-800-645-4174
Fax: 1-800-424-2082

Email: info@royalprod.com
www.royalprod.com