

EJM SERIES

An excellent choice for customers looking for a highly flexible, yet value-priced servo rated gearbox without sacrificing performance or durability. The EJM series comes in six different frame sizes to meet a wide range of application requirements and can support servo motors with up to 7.5kW capacity. Solid, hollow and double extended output shaft options allow for flexible machine design. The all-aluminum housing construction offers weight savings of up to 30% with improved thermal horsepower over cast iron.

The EJM series comes vent free and lubricated for life with synthetic oil, making it a reliable, maintenance-free solution. This product is ideally suited for applications within the packaging, material handling and general automation markets.

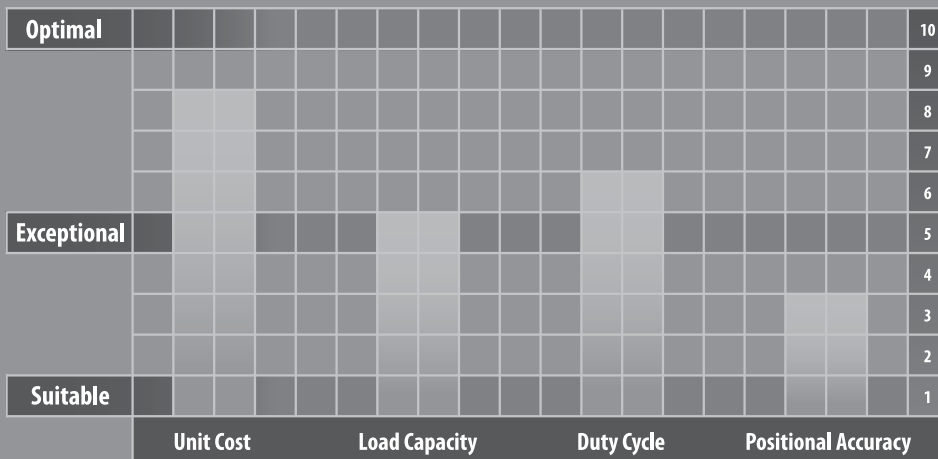



EJM SERIES

- Value engineered solution for less demanding servo applications
- Lightweight aluminum housing offers weight savings combined with improved thermal horsepower over cast iron
- Maintenance free solution; vent free and lubricated for life with synthetic oil
- Rated torque up to 614 Nm (up to 7.5 kw servo motor capacity)

EJM SERIES Right-angle Worm

EJM Series Features

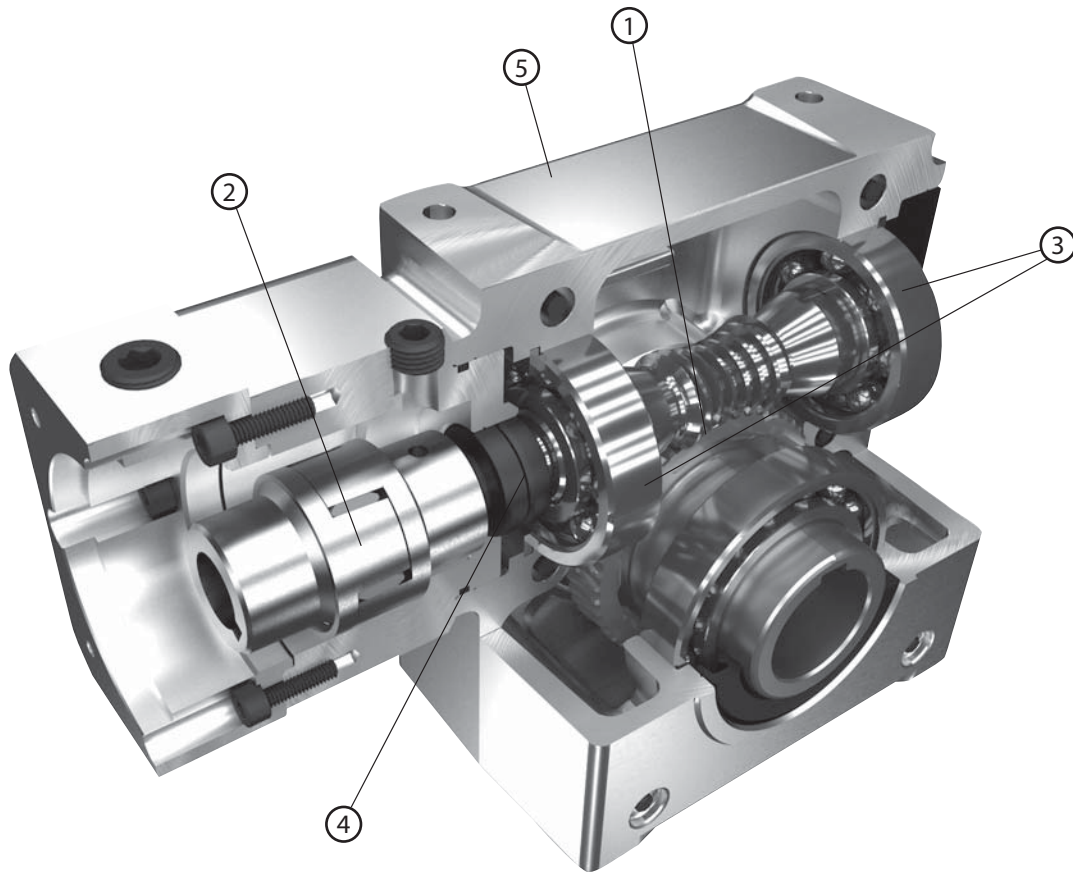

- ① Globoidal gear set – between 3-8 teeth in contact at once, allowing 300% shock load capacity
- ② Integrated zero backlash coupling provides fast, error free alignment
- ③ Ball bearings help reduce friction and heat, as compared to tapered roller designs
- ④ Double oil seal and o-ring provide IP65 protection
- ⑤ Thermally efficient, lightweight aluminum housing

EJM Series Model Code

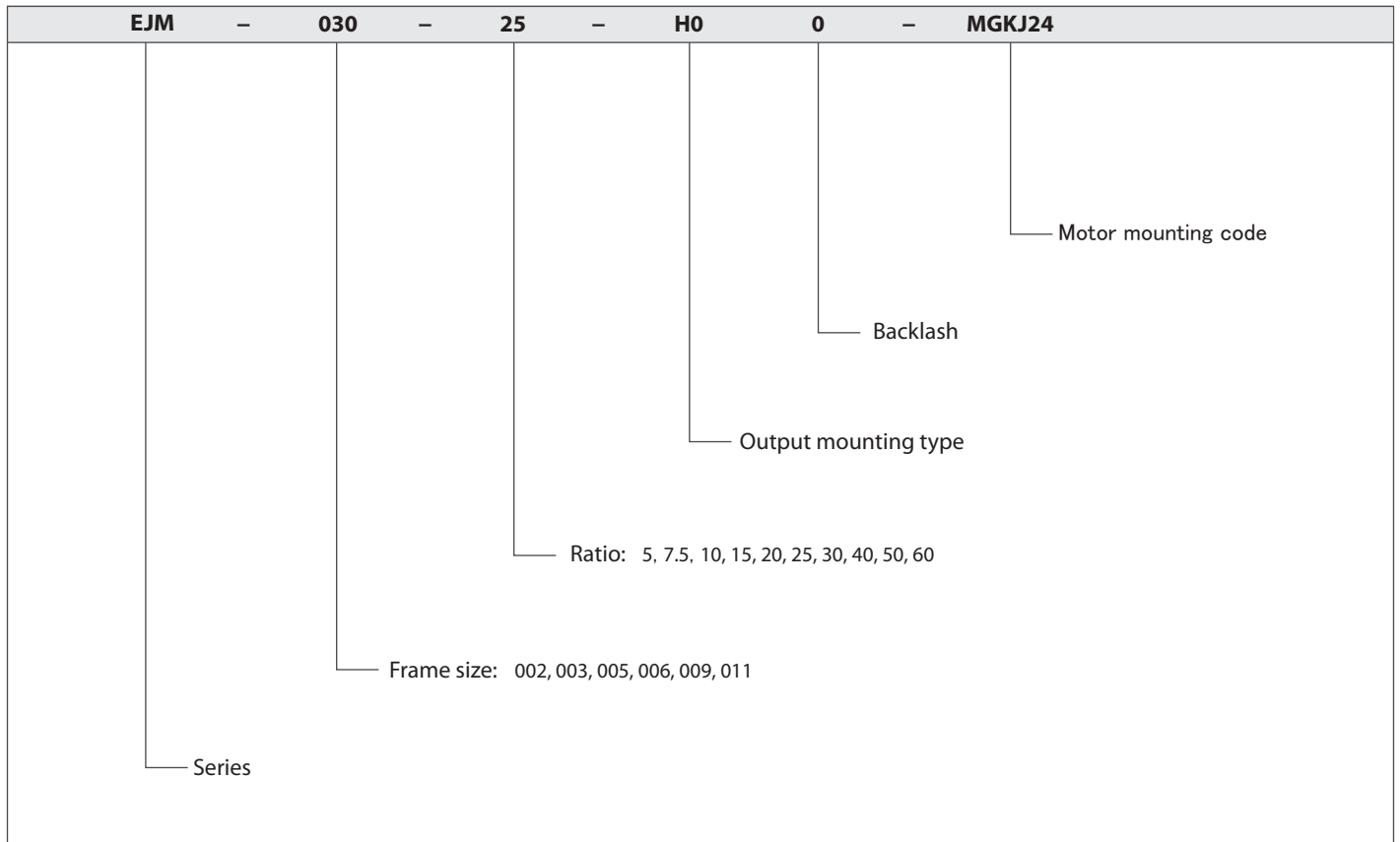

EJM

EJM SERIES Right-angle Worm

EJM 002 1-Stage Specifications

Frame Size	002						
Stage	1-Stage						
Ratio	Unit	Note	5	7.5	10	15	20
Nominal Output Torque	[Nm]	--	29	32	33	35	35
Maximum Acceleration Torque	[Nm]	--	38	40	33	42	43
Emergency Stop Torque	[Nm]	--	58	64	66	70	70
No Load Running Torque	[Nm]	*1	0.51				
Nominal Input Speed	[rpm]	--	2,000				
Maximum Continuous Input Speed	[rpm]	--	3,000				
Maximum Cyclic Input Speed	[rpm]	--	4,000				
Maximum Radial Load	[N]	*2	1,780				
Maximum Axial Load	[N]	*3	1,330				
Moment of Inertia	[kgcm ²]	--	0.36	0.33	0.32	0.31	0.31
Efficiency	[%]	*4	87	86	82	77	72
Torsional Rigidity	[Nm/arcmin]	--	1.0				
Maximum Torsional Backlash	[Arc-min]	--	≤ 41				
Noise Level	[dBA]	*5	≤ 73				
Ambient Temperature	[°C]	--	-25 ~ 93				
Permitted Housing Temperature	[°C]	--	100				
Protection Class	--	--	IP55				
Lubrication	--	--	Synthetic Oil				
Service Life	[Hours]	--	25,000				
Weight	[kg]	*6	3.2				

*1) Torque at no load applied to the input shaft at 2,000 rpm

*2) The maximum radial load the gearbox can accept

*3) The maximum axial load the gearbox can accept

*4) The efficiency at the nominal output torque rating

*5) Measured with no load applied to the input shaft at 2,000 rpm

*6) Weight may vary slightly between models

EJM 002 1-Stage Specifications

Frame Size	002						
Stage	1-Stage						
Ratio	Unit	Note	25	30	40	50	60
Nominal Output Torque	[Nm]	--	39	36	33	32	30
Maximum Acceleration Torque	[Nm]	--	48	45	39	38	36
Emergency Stop Torque	[Nm]	--	78	72	66	64	60
No Load Running Torque	[Nm]	*1	0.51				
Nominal Input Speed	[rpm]	--	2,000				
Maximum Continuous Input Speed	[rpm]	--	3,000				
Maximum Cyclic Input Speed	[rpm]	--	4,000				
Maximum Radial Load	[N]	*2	1,780				
Maximum Axial Load	[N]	*3	1,330				
Moment of Inertia	[kgcm ²]	--	0.30	0.30	0.30	0.30	0.30
Efficiency	[%]	*4	68	65	56	50	44
Torsional Rigidity	[Nm/arcmin]	--	1.0				
Maximum Torsional Backlash	[Arc-min]	--	≤ 41				
Noise Level	[dBA]	*5	≤ 73				
Ambient Temperature	[°C]	--	-25 ~ 93				
Permitted Housing Temperature	[°C]	--	100				
Protection Class	--	--	IP55				
Lubrication	--	--	Synthetic Oil				
Service Life	[Hours]	--	25,000				
Weight	[kg]	*6	3.2				

*1) Torque at no load applied to the input shaft at 2,000 rpm

*2) The maximum radial load the gearbox can accept

*3) The maximum axial load the gearbox can accept

*4) The efficiency at the nominal output torque rating

*5) Measured with no load applied to the input shaft at 2,000 rpm

*6) Weight may vary slightly between models

EJM SERIES Right-angle Worm

EJM 003 1-Stage Specifications

Frame Size	003						
Stage	1-Stage						
Ratio	Unit	Note	5	7.5	10	15	20
Nominal Output Torque	[Nm]	--	43	47	48	52	52
Maximum Acceleration Torque	[Nm]	--	56	59	51	61	63
Emergency Stop Torque	[Nm]	--	86	94	96	104	104
No Load Running Torque	[Nm]	*1	0.51				
Nominal Input Speed	[rpm]	--	2,000				
Maximum Continuous Input Speed	[rpm]	--	3,000				
Maximum Cyclic Input Speed	[rpm]	--	4,000				
Maximum Radial Load	[N]	*2	2,110				
Maximum Axial Load	[N]	*3	1,770				
Moment of Inertia	[kgcm ²]	--	0.75	0.64	0.61	0.58	0.57
Efficiency	[%]	*4	88	86	84	80	75
Torsional Rigidity	[Nm/arcmin]	--	1.9				
Maximum Torsional Backlash	[Arc-min]	--	≤ 30				
Noise Level	[dBA]	*5	≤ 75				
Ambient Temperature	[°C]	--	-25 ~ 93				
Permitted Housing Temperature	[°C]	--	100				
Protection Class	--	--	IP55				
Lubrication	--	--	Synthetic Oil				
Service Life	[Hours]	--	25,000				
Weight	[kg]	*6	5.4				

*1) Torque at no load applied to the input shaft at 2,000 rpm

*2) The maximum radial load the gearbox can accept

*3) The maximum axial load the gearbox can accept

*4) The efficiency at the nominal output torque rating

*5) Measured with no load applied to the input shaft at 2,000 rpm

*6) Weight may vary slightly between models

EJM 003 1-Stage Specifications

Frame Size	003						
Stage	1-Stage						
Ratio	Unit	Note	25	30	40	50	60
Nominal Output Torque	[Nm]	--	55	54	48	47	44
Maximum Acceleration Torque	[Nm]	--	67	65	58	57	53
Emergency Stop Torque	[Nm]	--	110	108	96	94	88
No Load Running Torque	[Nm]	*1	0.51				
Nominal Input Speed	[rpm]	--	2,000				
Maximum Continuous Input Speed	[rpm]	--	3,000				
Maximum Cyclic Input Speed	[rpm]	--	4,000				
Maximum Radial Load	[N]	*2	2,110				
Maximum Axial Load	[N]	*3	1,770				
Moment of Inertia	[kgcm ²]	--	0.57	0.56	0.56	0.56	0.56
Efficiency	[%]	*4	71	68	60	54	48
Torsional Rigidity	[Nm/arcmin]	--	1.9				
Maximum Torsional Backlash	[Arc-min]	--	≤ 30				
Noise Level	[dBA]	*5	≤ 75				
Ambient Temperature	[°C]	--	-25 ~ 93				
Permitted Housing Temperature	[°C]	--	100				
Protection Class	--	--	IP55				
Lubrication	--	--	Synthetic Oil				
Service Life	[Hours]	--	25,000				
Weight	[kg]	*6	5.4				

*1) Torque at no load applied to the input shaft at 2,000 rpm

*2) The maximum radial load the gearbox can accept

*3) The maximum axial load the gearbox can accept

*4) The efficiency at the nominal output torque rating

*5) Measured with no load applied to the input shaft at 2,000 rpm

*6) Weight may vary slightly between models

EJM SERIES Right-angle Worm

EJM 005 1-Stage Specifications

Frame Size	005						
Stage	1-Stage						
Ratio	Unit	Note	5	7.5	10	15	20
Nominal Output Torque	[Nm]	--	81	88	90	100	101
Maximum Acceleration Torque	[Nm]	--	105	112	100	120	123
Emergency Stop Torque	[Nm]	--	162	176	180	200	202
No Load Running Torque	[Nm]	*1	1.61				
Nominal Input Speed	[rpm]	--	2,000				
Maximum Continuous Input Speed	[rpm]	--	3,000				
Maximum Cyclic Input Speed	[rpm]	--	4,000				
Maximum Radial Load	[N]	*2	4,330				
Maximum Axial Load	[N]	*3	3,110				
Moment of Inertia	[kgcm ²]	--	1.83	1.55	1.45	1.39	1.36
Efficiency	[%]	*4	91	89	87	84	80
Torsional Rigidity	[Nm/arcmin]	--	3.1				
Maximum Torsional Backlash	[Arc-min]	--	≤ 23				
Noise Level	[dBA]	*5	≤ 80				
Ambient Temperature	[°C]	--	-25 ~ 93				
Permitted Housing Temperature	[°C]	--	100				
Protection Class	--	--	IP55				
Lubrication	--	--	Synthetic Oil				
Service Life	[Hours]	--	25,000				
Weight	[kg]	*6	7.3				

*1) Torque at no load applied to the input shaft at 2,000 rpm

*2) The maximum radial load the gearbox can accept

*3) The maximum axial load the gearbox can accept

*4) The efficiency at the nominal output torque rating

*5) Measured with no load applied to the input shaft at 2,000 rpm

*6) Weight may vary slightly between models

EJM 005 1-Stage Specifications

Frame Size	005						
Stage	1-Stage						
Ratio	Unit	Note	25	30	40	50	60
Nominal Output Torque	[Nm]	--	109	105	94	91	85
Maximum Acceleration Torque	[Nm]	--	132	127	114	109	102
Emergency Stop Torque	[Nm]	--	218	210	188	182	170
No Load Running Torque	[Nm]	*1	1.61				
Nominal Input Speed	[rpm]	--	2,000				
Maximum Continuous Input Speed	[rpm]	--	3,000				
Maximum Cyclic Input Speed	[rpm]	--	4,000				
Maximum Radial Load	[N]	*2	4,330				
Maximum Axial Load	[N]	*3	3,110				
Moment of Inertia	[kgcm ²]	--	1.35	1.34	1.34	1.33	1.33
Efficiency	[%]	*4	77	74	67	62	56
Torsional Rigidity	[Nm/arcmin]	--	3.1				
Maximum Torsional Backlash	[Arc-min]	--	≤ 23				
Noise Level	[dBA]	*5	≤ 80				
Ambient Temperature	[°C]	--	-25 ~ 93				
Permitted Housing Temperature	[°C]	--	100				
Protection Class	--	--	IP55				
Lubrication	--	--	Synthetic Oil				
Service Life	[Hours]	--	25,000				
Weight	[kg]	*6	7.3				

*1) Torque at no load applied to the input shaft at 2,000 rpm

*2) The maximum radial load the gearbox can accept

*3) The maximum axial load the gearbox can accept

*4) The efficiency at the nominal output torque rating

*5) Measured with no load applied to the input shaft at 2,000 rpm

*6) Weight may vary slightly between models

EJM SERIES Right-angle Worm

EJM 006 1-Stage Specifications

Frame Size	006						
Stage	1-Stage						
Ratio	Unit	Note	5	7.5	10	15	20
Nominal Output Torque	[Nm]	--	133	144	145	165	168
Maximum Acceleration Torque	[Nm]	--	172	183	154	186	207
Emergency Stop Torque	[Nm]	--	266	288	290	330	336
No Load Running Torque	[Nm]	*1	2.72				
Nominal Input Speed	[rpm]	--	2,000				
Maximum Continuous Input Speed	[rpm]	--	3,000				
Maximum Cyclic Input Speed	[rpm]	--	4,000				
Maximum Radial Load	[N]	*2	4,890				
Maximum Axial Load	[N]	*3	3,550				
Moment of Inertia	[kgcm ²]	--	2.61	2.02	1.81	1.66	1.61
Efficiency	[%]	*4	92	91	89	87	83
Torsional Rigidity	[Nm/arcmin]	--	5.6				
Maximum Torsional Backlash	[Arc-min]	--	≤ 20				
Noise Level	[dBA]	*5	≤ 80				
Ambient Temperature	[°C]	--	-25 ~ 93				
Permitted Housing Temperature	[°C]	--	100				
Protection Class	--	--	IP55				
Lubrication	--	--	Synthetic Oil				
Service Life	[Hours]	--	25,000				
Weight	[kg]	*6	10				

*1) Torque at no load applied to the input shaft at 2,000 rpm

*2) The maximum radial load the gearbox can accept

*3) The maximum axial load the gearbox can accept

*4) The efficiency at the nominal output torque rating

*5) Measured with no load applied to the input shaft at 2,000 rpm

*6) Weight may vary slightly between models

EJM 006 1-Stage Specifications

Frame Size	006						
Stage	1-Stage						
Ratio	Unit	Note	25	30	40	50	60
Nominal Output Torque	[Nm]	--	183	175	158	150	142
Maximum Acceleration Torque	[Nm]	--	223	212	191	181	170
Emergency Stop Torque	[Nm]	--	366	350	316	300	284
No Load Running Torque	[Nm]	*1	2.72				
Nominal Input Speed	[rpm]	--	2,000				
Maximum Continuous Input Speed	[rpm]	--	3,000				
Maximum Cyclic Input Speed	[rpm]	--	4,000				
Maximum Radial Load	[N]	*2	4,890				
Maximum Axial Load	[N]	*3	3,550				
Moment of Inertia	[kgcm ²]	--	1.58	1.57	1.56	1.55	1.55
Efficiency	[%]	*4	80	78	72	66	62
Torsional Rigidity	[Nm/arcmin]	--	5.6				
Maximum Torsional Backlash	[Arc-min]	--	≤ 20				
Noise Level	[dBA]	*5	≤ 80				
Ambient Temperature	[°C]	--	-25 ~ 93				
Permitted Housing Temperature	[°C]	--	100				
Protection Class	--	--	IP55				
Lubrication	--	--	Synthetic Oil				
Service Life	[Hours]	--	25,000				
Weight	[kg]	*6	10				

*1) Torque at no load applied to the input shaft at 2,000 rpm

*2) The maximum radial load the gearbox can accept

*3) The maximum axial load the gearbox can accept

*4) The efficiency at the nominal output torque rating

*5) Measured with no load applied to the input shaft at 2,000 rpm

*6) Weight may vary slightly between models

EJM SERIES Right-angle Worm

EJM 009 1-Stage Specifications

Frame Size	009						
Stage	1-Stage						
Ratio	Unit	Note	5	7.5	10	15	20
Nominal Output Torque	[Nm]	--	245	262	259	305	314
Maximum Acceleration Torque	[Nm]	--	317	333	259	312	386
Emergency Stop Torque	[Nm]	--	490	524	518	610	628
No Load Running Torque	[Nm]	*1	4.80				
Nominal Input Speed	[rpm]	--	2,000				
Maximum Continuous Input Speed	[rpm]	--	2,000				
Maximum Cyclic Input Speed	[rpm]	--	3,000				
Maximum Radial Load	[N]	*2	6,890				
Maximum Axial Load	[N]	*3	4,890				
Moment of Inertia	[kgcm ²]	--	12.4	10.5	9.87	9.40	9.24
Efficiency	[%]	*4	93	92	91	89	86
Torsional Rigidity	[Nm/arcmin]	--	15.5				
Maximum Torsional Backlash	[Arc-min]	--	≤ 15				
Noise Level	[dBA]	*5	≤ 83				
Ambient Temperature	[°C]	--	-25 ~ 93				
Permitted Housing Temperature	[°C]	--	100				
Protection Class	--	--	IP55				
Lubrication	--	--	Synthetic Oil				
Service Life	[Hours]	--	25,000				
Weight	[kg]	*6	20				

*1) Torque at no load applied to the input shaft at 2,000 rpm

*2) The maximum radial load the gearbox can accept

*3) The maximum axial load the gearbox can accept

*4) The efficiency at the nominal output torque rating

*5) Measured with no load applied to the input shaft at 2,000 rpm

*6) Weight may vary slightly between models

EJM 009 1-Stage Specifications

Frame Size	009						
Stage	1-Stage						
Ratio	Unit	Note	25	30	40	50	60
Nominal Output Torque	[Nm]	--	308	327	295	278	264
Maximum Acceleration Torque	[Nm]	--	376	369	356	335	317
Emergency Stop Torque	[Nm]	--	616	654	590	556	528
No Load Running Torque	[Nm]	*1	4.80				
Nominal Input Speed	[rpm]	--	2,000				
Maximum Continuous Input Speed	[rpm]	--	2,000				
Maximum Cyclic Input Speed	[rpm]	--	3,000				
Maximum Radial Load	[N]	*2	6,890				
Maximum Axial Load	[N]	*3	4,890				
Moment of Inertia	[kgcm ²]	--	9.17	9.12	9.08	9.07	9.06
Efficiency	[%]	*4	83	81	76	71	66
Torsional Rigidity	[Nm/arcmin]	--	15.5				
Maximum Torsional Backlash	[Arc-min]	--	≤ 15				
Noise Level	[dBA]	*5	≤ 83				
Ambient Temperature	[°C]	--	-25 ~ 93				
Permitted Housing Temperature	[°C]	--	100				
Protection Class	--	--	IP55				
Lubrication	--	--	Synthetic Oil				
Service Life	[Hours]	--	25,000				
Weight	[kg]	*6	20				

*1) Torque at no load applied to the input shaft at 2,000 rpm

*2) The maximum radial load the gearbox can accept

*3) The maximum axial load the gearbox can accept

*4) The efficiency at the nominal output torque rating

*5) Measured with no load applied to the input shaft at 2,000 rpm

*6) Weight may vary slightly between models

EJM SERIES Right-angle Worm

EJM 011 1-Stage Specifications

Frame Size	011						
Stage	1-Stage						
Ratio	Unit	Note	5	7.5	10	15	20
Nominal Output Torque	[Nm]	--	374	398	395	469	485
Maximum Acceleration Torque	[Nm]	--	486	506	477	577	597
Emergency Stop Torque	[Nm]	--	748	796	790	938	970
No Load Running Torque	[Nm]	*1	5.83				
Nominal Input Speed	[rpm]	--	2,000				
Maximum Continuous Input Speed	[rpm]	--	2,000				
Maximum Cyclic Input Speed	[rpm]	--	3,000				
Maximum Radial Load	[N]	*2	9,780				
Maximum Axial Load	[N]	*3	5,780				
Moment of Inertia	[kgcm ²]	--	25.3	19.8	17.9	16.5	16.0
Efficiency	[%]	*4	94	93	92	90	87
Torsional Rigidity	[Nm/arcmin]	--	28.4				
Maximum Torsional Backlash	[Arc-min]	--	≤ 12				
Noise Level	[dBA]	*5	≤ 85				
Ambient Temperature	[°C]	--	-25 ~ 93				
Permitted Housing Temperature	[°C]	--	100				
Protection Class	--	--	IP55				
Lubrication	--	--	Synthetic Oil				
Service Life	[Hours]	--	25,000				
Weight	[kg]	*6	30				

*1) Torque at no load applied to the input shaft at 2,000 rpm

*2) The maximum radial load the gearbox can accept

*3) The maximum axial load the gearbox can accept

*4) The efficiency at the nominal output torque rating

*5) Measured with no load applied to the input shaft at 2,000 rpm

*6) Weight may vary slightly between models

EJM 011 1-Stage Specifications

Frame Size	011						
Stage	1-Stage						
Ratio	Unit	Note	25	30	40	50	60
Nominal Output Torque	[Nm]	--	474	505	455	427	407
Maximum Acceleration Torque	[Nm]	--	580	614	551	514	489
Emergency Stop Torque	[Nm]	--	948	1010	910	854	814
No Load Running Torque	[Nm]	*1	5.83				
Nominal Input Speed	[rpm]	--	2,000				
Maximum Continuous Input Speed	[rpm]	--	2,000				
Maximum Cyclic Input Speed	[rpm]	--	3,000				
Maximum Radial Load	[N]	*2	9,780				
Maximum Axial Load	[N]	*3	5,780				
Moment of Inertia	[kgcm ²]	--	15.8	15.7	15.6	15.5	15.5
Efficiency	[%]	*4	84	83	78	73	69
Torsional Rigidity	[Nm/arcmin]	--	28.4				
Maximum Torsional Backlash	[Arc-min]	--	≤ 12				
Noise Level	[dBA]	*5	≤ 85				
Ambient Temperature	[°C]	--	-25 ~ 93				
Permitted Housing Temperature	[°C]	--	100				
Protection Class	--	--	IP55				
Lubrication	--	--	Synthetic Oil				
Service Life	[Hours]	--	25,000				
Weight	[kg]	*6	30				

*1) Torque at no load applied to the input shaft at 2,000 rpm

*2) The maximum radial load the gearbox can accept

*3) The maximum axial load the gearbox can accept

*4) The efficiency at the nominal output torque rating

*5) Measured with no load applied to the input shaft at 2,000 rpm

*6) Weight may vary slightly between models

EJM SERIES Right-angle Worm

EJM Dimensions – Hollow Output Shaft

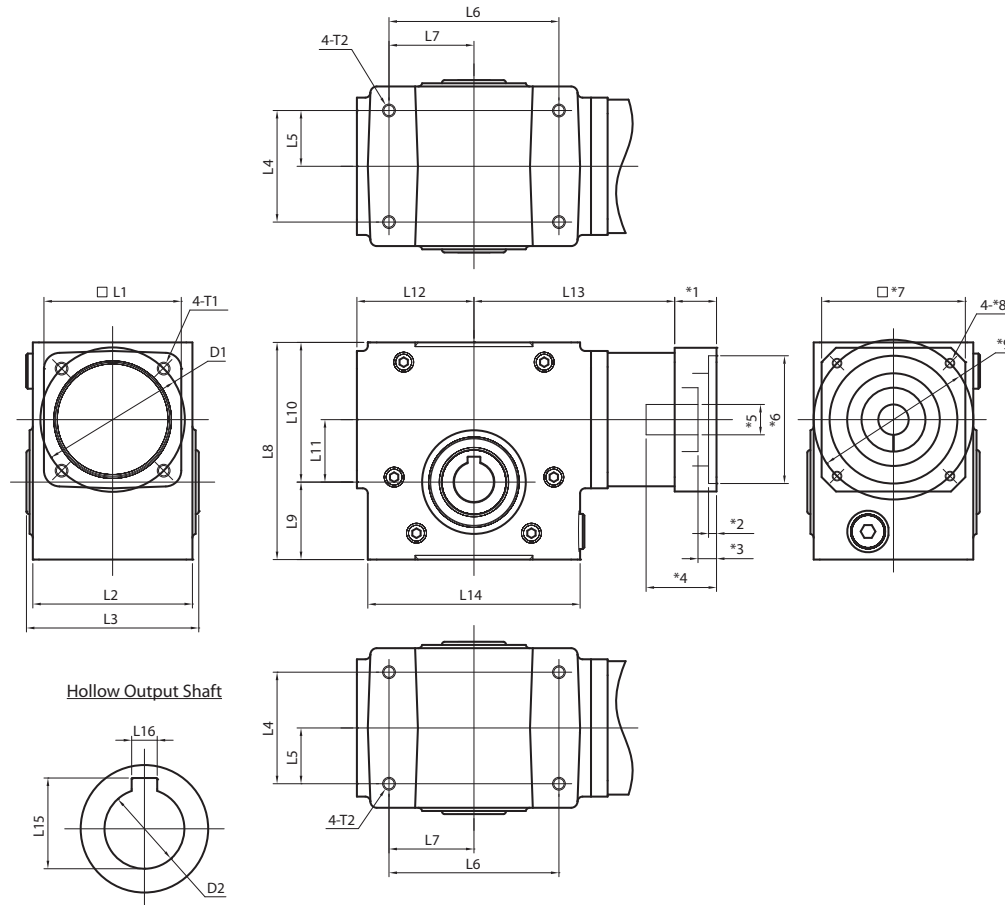

Frame Size	Unit	Note	EJM-002	EJM-003	EJM-005	EJM-006	EJM-009	EJM-011
L1	[mm]	--	60	86	86	86	116	116
L2	[mm]	--	70	100	100	100	130	130
L3	[mm]	--	98	108	107	108	138	169
L4	[mm]	--	51	70	73	73	102	102
L5	[mm]	--	25	35	37	37	51	51
L6	[mm]	--	83	106	127	127	178	191
L7	[mm]	--	41	53	64	64	89	95
L8	[mm]	--	118.5	136	162	176	225.5	250
L9	[mm]	--	43.5	48.5	58	63.5	82.5	86
L10	[mm]	--	75	87.5	104	112.5	143	164
L11	[mm]	--	33.8	39.1	50.0	60.5	76.2	89.9
L12	[mm]	--	67	73	84	95	117	130
L13	[mm]	--	126	126	136	147	184	197
L14	[mm]	--	110	133	152	178	229	241
L15	[mm]	--	23	28.5	38.5	38.5	59.5	80
L16	[mm]	--	6	8	10	10	16	20
D1	[mm]	--	ø64	ø90.5	ø90.5	ø90.5	ø127	ø127
D2 (H7)	[mm]	--	ø20	ø25	ø35	ø35	ø55	ø75
T1	[mm]	--	M8x12	M8x12	M8x12	M8x12	M8x12	M8x12
T2	[mm]	--	M8x12	M8x12	M10x15	M10x15	M12x18	M16x24
*1 ~	[mm]	*9	Motor attachment dimensions are made to fit your servo motor.					

EJM Dimensions – Solid Output Shaft

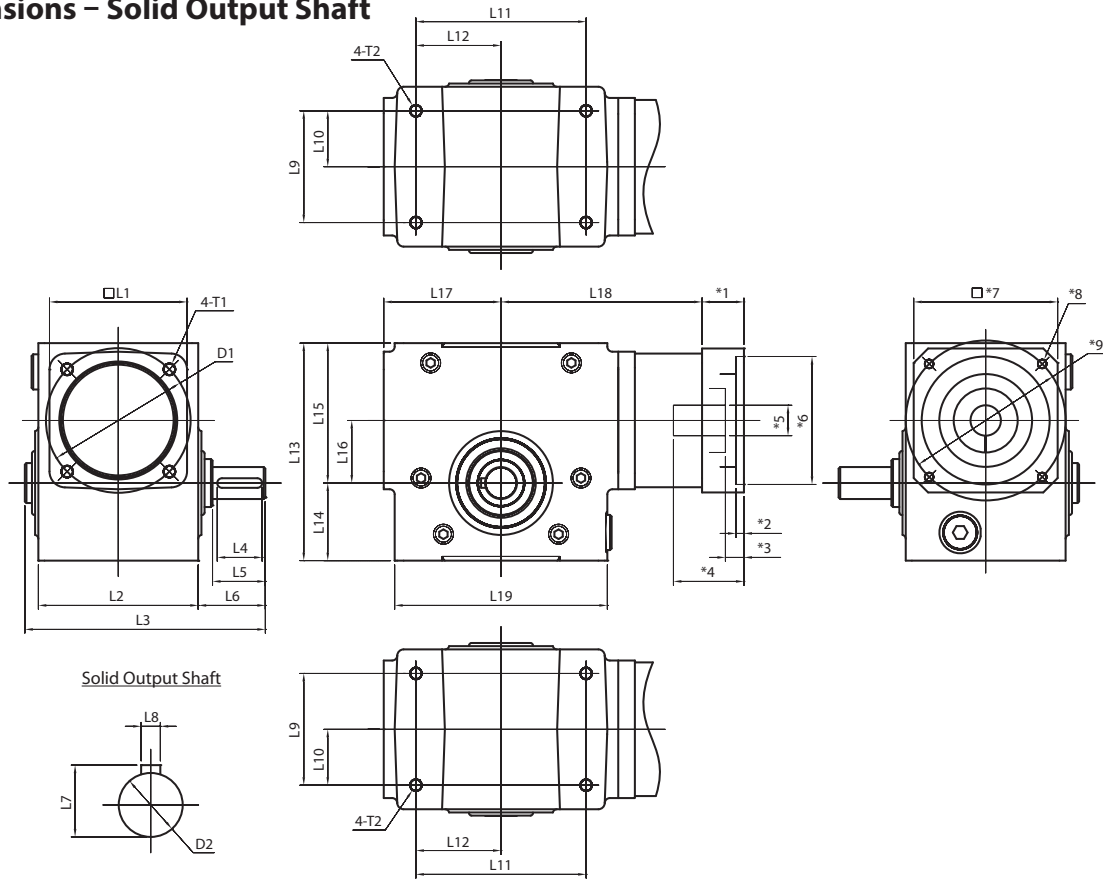

Solid Output Shaft

Frame Size	Unit	Note	EJM-002	EJM-003	EJM-005	EJM-006	EJM-009	EJM-011
L1	[mm]	--	60	86	86	86	116	116
L2	[mm]	--	70	100	100	100	130	130
L3	[mm]	--	140.5	150.5	156	173	204	261
L4	[mm]	--	28	28	36	50	50	70
L5	[mm]	--	33	33	39	55	54	79
L6	[mm]	--	52	42	48	64	64	105
L7	[mm]	--	22.5	22.5	28	33	38	45
L8	[mm]	--	6	6	8	8	10	12
L9	[mm]	--	51	70	73	73	102	102
L10	[mm]	--	25.5	35	36.5	36.5	51	51
L11	[mm]	--	83	106	127	127	178	191
L12	[mm]	--	41.5	53	63.5	63.5	89	95.5
L13	[mm]	--	118.5	136	162	176	225.5	250
L14	[mm]	--	43.5	48.5	58	63.5	82.5	86
L15	[mm]	--	75	87.5	104	112.5	143	164
L16	[mm]	--	33.8	39.1	50.0	60.5	76.2	89.9
L17	[mm]	--	67	73.5	84	95	117	130
L18	[mm]	--	125.5	125.5	136.5	147.5	184	197
L19	[mm]	--	110	133	152.5	178	228.5	241.5
D1	[mm]	--	ø64	ø90.5	ø90.5	ø90.5	ø127	ø127
D2 (h6)	[mm]	--	ø20	ø20	ø25	ø30	ø35	ø42
T1	[mm]	--	M8 x12	M8 x12	M8 x12	M8 x12	M8 x12	M8 x12
T2	[mm]	--	M8 x12	M8 x12	M10 x15	M10 x15	M12 x18	M16 x24
*1 ~	[mm]	*9	Motor attachment dimensions are made to fit your servo motor.					