

AD-A116 834

ROYAL MILITARY COLL OF SCIENCE SHRIVENHAM (ENGLAND) --ETC F/G 9/5  
A SURVEY OF FLAT PROFILE MICROWAVE ANTENNAS. (U)  
APR 77 P S HALL, J R JAMES

UNCLASSIFIED

RT-103

DRIC-BR-56300

NL

for 1

of 1

of 1

of 1

of 1

of 1

of 1

of 1

of 1

of 1

of 1

of 1

of 1

of 1

of 1

of 1

of 1

of 1

of 1

of 1

of 1

of 1

of 1

of 1

of 1

of 1

of 1

of 1

of 1

of 1

of 1

of 1

of 1

of 1

of 1

of 1

of 1

of 1

of 1

of 1

of 1

of 1

of 1

of 1

of 1

of 1

of 1

of 1

of 1

of 1

of 1

of 1

END

DATE

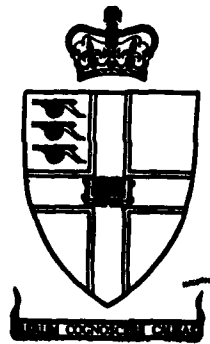
FILED

8-82

DTIC

THE  
ROYAL MILITARY  
COLLEGE OF SCIENCE

DTIC FILE COPY · AD A116834



DTIC  
ELECTED  
JUL 9 1982  
H

DEPARTMENT OF ELECTRICAL AND ELECTRONIC ENGINEERING

DISTRIBUTION STATEMENT A  
Approved for public release;  
Distribution Unlimited

82 07 06 186

UNLIMITED

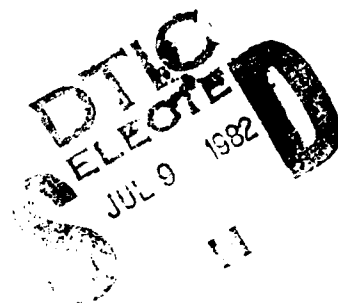
BR 56300  
RT 103

TECHNICAL NOTE RT 103

A SURVEY OF FLAT PROFILE MICROWAVE  
ANTENNAS

by

P.S.Hall and J.R.James



ABSTRACT

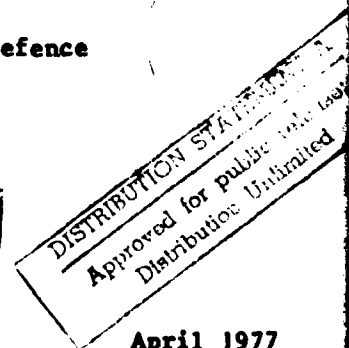
The need for compact low profile antenna elements and arrays has in the past decade inspired many ingenious techniques embracing both conventional waveguides and the more recent printed assemblies. While printed techniques appear to offer more attractive features it is instructive to note all the various configurations that have been considered because some of the electrical constraints are similar. This report is an outline survey of such radiators and although it is not the intention to discuss any particular antenna in depth, sufficient details and references are given, where available, to indicate the performance obtained and the device potential.

Prepared for Procurement Executive Ministry of Defence

Contract Number AT/2160/033 RL

Department of Electrical and Electronic Engineering  
Royal Military College of Science  
Shrivenham  
SWINDON  
Wilts  
SN6 8LA  
England

APRIL 1977



## CONTENTS

	<u>Pages</u>
Abstract	i
CONTENTS LIST	ii
1. MICROSTRIP ANTENNAS	1
1.1 Theory	1
1.1.1 Microstrip Transmission	1
1.1.2 Radiation Mechanism	1
1.1.3 Surface Waves	2
1.2 Microstrip Resonant Radiators	2
1.2.1 Narrow Line Resonant Radiators	2
1.2.2 Broad Line Resonant Radiators	3
1.3 Strip Radiators	4
1.4 Non-Rectangular Resonant Radiators	5
1.5 Comb Line Arrays	6
1.6 The Chain Antenna	7
1.7 The Serpent Line Antenna	7
1.8 Coplanar Stripline Antennas	7
1.9 Summary Comment	8
2. Cavity Backed Printed Antennas	9
2.1 The Sandwich Wire Antenna	9
2.1.1 Theory	9
2.1.2 Practical Antennas	9
2.2 Printed Dipoles	10
2.3 Printed Colinear Dipole Arrays	11
2.3.1 The Franklin Antenna	11
2.3.2 Capacitively Coupled Colinear Array	11
2.4 The Ground Plane Slot Radiator	11
2.5 Summary Comments	12
3. STRIPLINE	13
3.1 Theory	13

3.1.1	Stripline Transmission	13
3.1.2	Radiation from Stripline Slot	13
3.2	Cavity Backed Slots	14
3.2.1	Theory	14
3.2.2	Practical Stripline Antennas	14
3.3	Periodically Modulated Radiator	15
3.4	Summary Comments	16
4.	WAVEGUIDE FLAT PROFILE ANTENNAS	17
4.1	Waveguide Slots	17
4.1.1	Basic Slot Types	17
4.1.2	Further Slot Types	17
4.2	Slot Arrays	19
4.2.1	Linear Arrays	19
4.2.2	Two Dimensional Arrays	20
4.3	Summary Comments	20
5.	MANUFACTURING TOLERANCES OF FLAT PROFILE ANTENNAS	22
5.1	Theory	22
5.2	Practical Examples - Waveguide Arrays	23
5.3	Practical Examples - Printed Arrays	23
5.4	Summary Comments	24
6.	CONCLUSIONS	25
7.	ACKNOWLEDGEMENTS	28
8.	REFERENCES	29
9.	LIST OF SYMBOLS	37
10.	TABLES	39
Table 5.1	Line Impedance Errors due to Substrate Dimensional Errors	39
Table 6.1	Summary of Achieved Flat Profile Antenna Performance	40
Table 6.2	Comparison of Flat Profile Antenna Classes	42

Accession For	
GRA&I	<input checked="" type="checkbox"/>
...	<input type="checkbox"/>
...	<input type="checkbox"/>
By: _____	
Distribution/ _____	
Availability Codes _____	
and/or _____	
Distributional _____	



<b>11. ILLUSTRATIONS</b>	<b>43</b>
1.1 Microstrip Transmission Line	43
1.2 Microstrip Geometry	43
1.3 Microstrip Discontinuities	44
a) Open Circuit Line	44
b) Matched Coaxial Transition	44
c) Right Angle Corner	44
1.4 Narrow Line Resonant Radiator	45
1.5 Linear Array of Resonant Radiators	45
1.6 Resonant Radiator Fed Directly by Line	45
1.7 Circularly Polarised Narrow Line Resonant Radiator	45
1.8 Broad Line Resonant Radiator	46
1.9 Array of Resonant Radiators	46
1.10 Circularly Polarised Broad Resonant Radiator	46
1.11 Circularly Polarised Dual Frequency Resonant Radiator	47
1.12 Strip Radiator (Byron)	47
1.13 Strip Radiator (Munson)	47
1.14 Circular Resonant Radiator	47
1.15 Circularly Polarised Circular Resonant Radiator	48
1.16 Circularly Polarised Resonant Radiator (James & Wilson)	48
1.17 Comb Line Arrays	48
a) Linear	48
b) Two Dimensional	48
c) Zig-Zag	48
1.18 Chain Antenna	49
1.19a Coplanar Stripline Geometry	49
1.19b Coplanar Stripline Broad Line Resonant Radiator	49
2.1 The Sandwich Wire Antenna: Basic Configuration	50
2.2 The Sandwich Wire Antenna: Practical Design	50
2.3 Monopulse Array of Sandwich Wire Antennas	51

2.4	Printed Dipole	51
2.5	Stripline Fed Printed Dipole	52
2.6	Broadband Printed Dipole	52
2.7	Flat Slot and Dipole Configuration	53
2.8	Colinear Dipole Arrays	53
	a) Franklin Antenna	53
	b) Capacitively Coupled Array	53
2.9	The Ground Plane Slot Radiator	53
3.1	Stripline Transmission Line	54
3.2	Stripline Slot Radiator	54
3.3	Array of Stripline Slots	54
3.4	Practical Slot Design	55
3.5	32 Element Slot Array	55
3.6	Periodically Modulated Radiator	55
4.1	Typical Waveguide Flat Profile Array Antenna	56
4.2	Squintless Feed System	56
4.3	Basic Slot Types	57
	a) Longitudinal Slot in Broad Face; Shunt Element	57
	b) Transverse Slot in Broad Face; Series Element	57
	c) Centred Inclined Slot in Broad Face; Series Element	57
	d) Inclined Slot in Narrow Face; Shunt Element	57
4.4	Dumbbell and 'H' Slot	58
4.5	'H' Slot in Narrow Wall of Waveguide	58
4.6	'I' Slot	58
4.7	Probe and Iris Fed Slots	59
4.8	Slot with Parasitic Wires	59
4.9	Circularly Polarised Slot Radiators	59
4.10	Section of Circularly Polarised Planar Array	60
4.11	Slot for Arbitrary Polarisation	60
4.12	Leaky Wave Radiator	60

12. APPENDIX: Measurement of Attenuation and Phase Constants of

Travelling Wave Antennas

61

13. DOCUMENT CONTROL SHEET

62



## 1. MICROSTRIP ANTENNAS

Microstrip is a form of strip transmission line and its geometry is shown in cross section in Fig. 1.1. It was conceived in 1952,(1), but development of its uses at microwave frequencies was slow due to lack of low dielectric constant material and processing difficulties. These problems have now been overcome and there is a renewed interest in microstrip both for microwave integrated circuits and antennas.

### 1.1 Theory

#### 1.1.1 Microstrip Transmission

A large volume of literature exists on the mechanism of microstrip transmission, (2), and only those references which are useful in introducing the problems involved are quoted here.

The fact that propagation takes place in a non homogeneous medium, two dielectrics being present, means that a true TEM mode of propagation cannot exist. However, the field configuration of the actual mode of propagation closely resembles the TEM structure and in the majority of cases of practical interest the "pseudo-TEM" mode assumption is well justified.

The parameters required for design of microstrip devices are line impedance,  $Z_m$ , and effective dielectric constant,  $\epsilon_{eff}$ , which is used to determine the wavelength in the line,  $\lambda_m$ . Wheeler, (3), has derived expressions for these, using a conformal transformation technique. He presents expressions for synthesis, that is, determination of  $w/h$  and  $\epsilon_{eff}$  (see FIG 1.2) given  $Z_m$  and  $\epsilon_d$ , the substrate dielectric constant, and for analysis, that is determination of  $Z_m$  and  $\epsilon_{eff}$  given  $w/h$  and  $\epsilon_d$ . Wheeler's analysis produces two sets of expressions each valid below and above a certain value of  $w/h$ . Wheeler chooses this crossover value as 2. Hammerstad, (4), has compared the results of Wheeler's expressions to those given by an accurate but quite complex method involving Greens functions. By adjusting some of the constants he has reduced the errors from about 4% to less than 1%. Owens, (5), has adopted the same approach but reduced both the discontinuity and absolute errors by altering the crossover point.

Wheeler's approach is fundamentally electrostatic and has limitations at high frequencies. For high dielectric constant materials ( $\epsilon_d = 10$ ) dispersion has been noticed at 1GHz and differences of 10% in  $Z_m$  and  $\epsilon_{eff}$  from electrostatic values occur at 10 GHz,(6). Schmitt and Sarges,(7), have described a dynamic solution to microstrip propagation, which agree well with measurements of the phase constant of the line.

Hammerstad, (8), has given expressions for the conductor and dielectric losses in microstrip. In microstrip the conductor losses predominate. At 18 GHz the loss is typically 0.1 dB/line wavelength.

#### 1.1.2 Radiation Mechanism

Radiation from discontinuities in microstrip was first examined by Lewin, (9), who derived the radiated fields from the currents flowing in the conductors. He established the radiation patterns for basic radiating elements such as the open circuit line, the matched coaxial transition (with the coaxial inner conductor penetrating the substrate) and the right angle corner, all shown in FIG. 1.3. Further work, based on Lewin's analysis, has been done on open circuit resonators operating in the fundamental mode, (10, 11), and in higher order modes (12). James and Wilson (13, 14) have shown that an open-circuited microstrip line behaves

in a similar way to an open ended dielectric rod antenna. They have adopted an aperture method to analyse the radiation from a microstrip open circuit and show that microstrip resonators do not behave like metallic dipoles but like magnetic Hertzian dipoles shaped by a space factor dependent on the length of the resonator.

A knowledge of the admittance,  $Y_e$ , of the end of an open circuit line is necessary for design of arrays of such resonators, (15). The admittance is, in general, complex,  $Y_e = G_e + jB_e$ . The real part of the admittance,  $G_e$ , the radiation conductance, has been calculated by Sobol, (17), but Kompa's calculations, (18), show that these are too low by a factor of ten. James and Wilson, (14), have performed measurements which show that Sobol's values are indeed too low. Hammerstad (4), has given an empirical formula for the end susceptance,  $B_e$ , which substantially agrees with James and Wilson's measurements below about 10 GHz.

### 1.1.3 Surface Waves

An open circuit microstrip line will not only reflect and radiate energy incident upon it, but also launch part of that energy in the form of a surface wave. This problem has not been examined deeply; James and Ladbroke, (19), have shown, using a simple first order analysis, that typically for alumina based microstrip  $\frac{1}{50}$  of the incident power can be launched into the surface wave. This surface wave could be of significance in microstrip arrays where very low sidelobe levels are required. James and Ladbroke suggest troughs cut in the substrate close to the open circuit as a means of suppression.

## 1.2 Microstrip Resonant Radiators

Microstrip resonant radiators are formed by exciting a microstrip line an integer number of half line wavelengths,  $\frac{n\lambda_m}{2}$ , long terminated by an open circuit at each end. Each open circuit forms a radiating element and the length of the resonator determines the resulting radiation pattern. There are two basic types of resonant radiator;

- i) Narrow Line resonators formed by a line of 50  $\Omega$  impedance
- ii) Broad impedance line resonators formed by low impedance lines

### 1.2.1 Narrow Line Resonant Radiators

The basic narrow line resonant radiator is shown in FIG 1.4. James and Wilson, (13), have measured the radiation pattern of half wavelength and wavelength long elements and shown that they agree well with theory. They also describe a linear array of 9 elements placed close to a feed line as shown in FIG 1.5. It is important to ensure that the element centres correspond to the low impedance points on the feed line so that the elements are correctly excited. The array has a uniform amplitude distribution and the resulting first sidelobe level of the radiation pattern is -12.5 dB, close to the theoretical level of -13 dB. This suggests that the radiation characteristics of the array are under control. James and Wilson also demonstrate the effect of cutting troughs close to the open circuits. This substantially lowers the far out sidelobes and improves agreement with theory. These sidelobes are of the order of -20 dB.

Two dimensional arrays of this type are now available commercially, (20), in various combinations of E and H plane beamwidths from  $4^\circ \times 8^\circ$  to  $60^\circ \times 90^\circ$  respectively. E and H plane first sidelobe levels of -12 dB and -18 dB respectively

can be achieved, and antennas can be manufactured to work at centre frequencies from 2 to 36 GHz. Performance is maintained over a relatively narrow band which is given by:

$$\frac{+ \text{ minimum beamwidth}}{10}$$

These arrays are centre fed in order that a symmetrical distribution exists across the array which will ensure that the sidelobe level is suppressed. This suggests that each half of the array has a linear excitation taper produced by constant spacing between the elements and the line.

Methods of varying the coupling between the feed line and the elements have been proposed in a patent application, (21). These consist essentially of varying the distance between the line and element. These variations could be used to give a predetermined excitation amplitude distribution across the array, thus reducing the sidelobes.

Ideas for a dual frequency array, in which elements of different lengths are placed on either side of the line and for a wide band array, in which the element length is tapered across the width of the line are also shown. However no arrays have been seen by the authors which make use of any of these methods.

James and Wilson, (22), have shown that a narrow line resonant radiator can be excited by direct connection to a 50  $\Omega$  transmission line. This is done by offsetting the feed line from the centre of the element as depicted in Fig. 1.6. They have used this element to form a circularly polarised radiator as shown in FIG. 1.7. This element will, of course have a bandwidth dependent on substrate height and dielectric constant but is typically less than one percent at 2.6 GHz using a  $\frac{\lambda_m}{80}$  substrate height.

### 1.2.2 Broad Line Resonant Radiators

A broad line resonant radiator, shown in FIG. 1.8, consists of a square or rectangular patch in microstrip which is excited by a line joining the patch at the centre of one edge. A mode is excited in the resonator which has an approximately uniform field distribution parallel to the dimensions  $w$  and a sinusoidal field distribution parallel to the  $\frac{\lambda_m}{2}$  dimension. The resonator radiates from the apertures formed by the sides marked R and the ground plane. The fields in the two slots are in antiphase; however their components parallel to the ground plane reinforce and energy is radiated in a direction normal to the ground plane. Howell, (23), describes such an element, which has been empirically designed. Derneryd, (24), has described a transmission line approach to their analysis and shows that the bandwidth of the radiator is typically a few percent.

Derneryd states that the bandwidth of these broad line radiators can be increased by decreasing their width. This statement assumes that the ratio  $\frac{Y_c}{G_e}$ , where  $Y_c$  is the line admittance of the resonator and  $G_e$  the conductance of the apertures at each end, increases as the line width is increased. The authors however have found that this is not the case and that  $G_e$  increases more rapidly than  $Y_c$  with increasing width, where  $G_e$  is taken from Derneryd's analysis and  $Y_c$  from the expressions of Wheeler (3). This means that the bandwidth is proportional to line width. This conclusion agrees with the well known principle that antenna bandwidth is, in general, proportional to aperture size.

Derneryd also shows a linear travelling wave array of four radiators having a 2:1 VSWR, bandwidth of 1½% and a radiated sidelobe level of about -11 dB in the E plane. The array operates at X band and has a substrate height about  $\frac{\lambda_m}{30}$ . In a later paper, (25), he describes a two-dimensional array of these patch radiators, shown in FIG. 1.9, which can be excited in either linear polarisation by feeding in at points (1) or (2). The sidelobe levels are consistent with his linear array and the isolation between the polarisations is about 20 dB.

Derneryd has shown that these elements can be excited by lines connected to the orthogonal sides. If these two sides are excited at the same frequency and 90° out of phase then the radiation will be circularly polarised as shown in FIG. 1.10(a). This principle has been demonstrated by Howell, (23), Munson, (26), and Sanford and Klein, (27), Munson showing that the axial ratio is better than about 2 dBs over a 150° beamwidth over a bandwidth of a few percent. Ostwald and Garvin, (28), describe how the feeding can be simplified to a single line as shown in FIG. 1.10(b). Here the feed line is attached at the resonator corner. The lengths,  $w_1$  and  $w_2$ , of the resonator are:-

$$w_1 = \frac{n\lambda_m}{2} + \Delta \quad \dots\dots\dots 1.1$$

$$w_2 = \frac{n\lambda_m}{2} - \Delta \quad \dots\dots\dots 1.2$$

where  $\Delta$  is a small length such that the imaginary part of the two orthogonal mode admittances is equal and opposite in sign and equal to the real part of the mode admittance. This means that the amplitude of the modes are equal but their phases are +45° and -45° so that the radiated fields are in phase quadrature. This is the condition for circular polarisation. The hand of polarisation can be changed by interchanging dimensions  $w_1$  and  $w_2$  or by feeding from an adjacent corner. In the resonator fed from two sides through a 90° hybrid coupler both hands of polarisation can be obtained, one from each output of the hybrid coupler.

Circularly polarised resonating elements are used widely on satellite links, conformal linear arrays of them being described by Ostwald and Garvin, (28), and Sanford and Klein, (27), the latter incorporating PIN diode phase shifters into the microstrip corporate feed system to produce a phase scanned array system.

Sanford and Munson, (29), show a dual frequency circularly polarised resonant radiator. This employs a rectangular patch with a rectangular gap some way in from the edge as shown in FIG. 1.11. The gap is bridged by tuned sections of coaxial line so that at the higher frequency the inner rectangle is excited and at the lower frequency the gap is bridged and the complete square is excited. The feed point is close to one corner of the inner rectangle so that the resultant polarisation is circular.

### 1.3 Strip Radiators.

Microstrip strip radiators are essentially derived from broad line resonant radiator arrays. Byron, (30), describes a strip radiator which is shown in FIG. 1.12. This is an array of resonating cells, each cell being defined by a row of rivets or other devices shorting the strip to the ground plane, on each side. The cell is fed at one point close to one radiating edge. If the rivets are not present then the cell must be fed at two points as in the circular resonant radiator (section 1.4). Each cell radiates in the same way as the broad line resonant radiator (section 1.2.2) that is from the top and bottom edges, in antiphase. A 29 element array of these cells was tested and the radiation patterns were well behaved over a 12% bandwidth. It was also found that the element

with external matching in the coaxial feed line, was the best matched for a  $\frac{\lambda_m}{12}$  ground plane spacing, having a VSWR  $< 1.3$  over a 12% bandwidth.

Using the same type of transmission line analysis as used by Derneryd, (24), Munson, (26), has developed a strip radiator that is shown in FIG. 1.13. Operating in the fundamental mode ( $n=1$ ), the device is basically a very broad resonant radiator. The resistance of the slot AA, which in an example given by Munson for  $L = 2 \lambda_m$  is about  $60 \Omega$ , is transformed across the very low impedance line and added in parallel to the resistance of the slot BB to give an input resistance of  $30 \Omega$ . This is fed by four  $120 \Omega$  lines from a corporate feed. The number of feed points must exceed the number of wavelengths in the dimension L if only a TEM mode is to be excited in the strip. Munson describes the use of conformal strip radiators for wrapping round missiles to give omnidirectional coverage and a flat array of four strip radiators having radiation normal to their plane. The array has a uniform distribution on it and achieves -11 dB sidelobes. These radiators have a bandwidth of about 1% for a VSWR 2:1 and operates at X-band with a substrate height of  $\frac{\lambda_m}{150}$ . Methods for increasing the bandwidth are mentioned by Munson and include

- 1) increasing the substrate height
- 2) increasing the substrate dielectric constant.
- 3) cutting holes or slots into the microstrip radiator to increase the inductance.

These methods, however, decrease the efficiency of the radiator and in fact could be achieved by using a more lossy substrate.

#### 1.4 Non-Rectangular Resonant Radiators

Most work done on non-rectangular resonant radiators has centred around the circular elements. A circular element fed in anti-phase at two points to produce a linearly polarised radiator, shown in FIG. 1.14, is described by Byron (30) after an original patent application by Colling (31). This element, fed from behind the ground plane, has a charge distribution equal in magnitude and opposite in phase at the top and bottom of the disc. This will produce a radiated field which is vertically polarised (in FIG. 1.14) and is maximum normal to the disc. The element can also be fed at one point and grounded at the centre, thus simplifying the feed system.

The Colling radiator has been extended to produce circular polarisation as suggested by Byron by feeding it at an additional pair of points, as shown in FIG. 1.15, by Brain and Mark, (32). The additional pair of points are fed in phase quadrature to the first pair. The feed system was constructed in stripline (triplane) beneath the ground plane of the radiator. With a broadband feed network the element is capable of producing circularly polarised radiation with ellipticity of 2 dB over a beam of  $40^\circ$  semiangle over a bandwidth of 25%. With the simple feed network used, a VSWR of  $< 1.2:1$  has been achieved over a 12% bandwidth. The orthogonally polarised channels, which are available from each arm of a  $90^\circ$  hybrid coupler as described previously for feeding the broad line resonant radiator of 1.2.2, have an isolation of 13 dB.

Munson, (26), has shown that the circular resonant element which is grounded at the centre can be excited at only two points in phase quadrature to produce a circularly polarised beam of  $< 2$  dB ellipticity over a beam of  $90^\circ$  semi angle. He states that the bandwidth of the antenna is from a fraction to a few percent depending on the substrate dielectric constant and thickness.

Elliptical resonators have been suggested by Irish, (33), and James and Wilson (34), have shown that these, fed by a microstrip line in the same plane as the resonator will produce good circular polarisation over a small bandwidth. The element is shown in FIG. 1.16. James and Wilson have also shown how to calculate the radiation patterns of such resonators.

### 1.5 Comb Line Arrays

By utilising a comb like layout of microstrip lines, as shown in FIG. 1.17(a), James and Wilson, (16), have produced a resonant linear array having -20 dB sidelobes. The basic element is an approximately half-wavelength long line, open circuit at one end and connected to the feeder at the other. Thus, if the element length, including end and T-junction effects, is half a wavelength then the radiation resistance will effectively appear across the feed line. The radiation resistance is controlled by varying the line width as described in section 1.1.2. James and Wilson, (14), have shown by measurement, using a standing wave technique, that the end conductance,  $G_e$ , and width,  $W$ , are related by

$$G_e = \frac{K}{(W)^q} \dots\dots\dots 1.3$$

This relationship was used to design the linear array for a theoretical sidelobe level of -24 dB. Sidelobe levels of -20 dB were obtained over a 1% bandwidth at 10 GHz.

A 9 x 9 element two dimensional resonant array has also been constructed, FIG. 1.17(b), to have a theoretical sidelobe level of -24 dB in each plane. Sidelobe levels of -17 dB and -14 dB being measured in the H and E plane respectively, over a 1% bandwidth. By reducing the element widths the H plane sidelobes were reduced to -20 dB but at the expense of bandwidth. The poor sidelobe level in the E plane is due to the heavy loading of each comb on the comb feed line thus disturbing the distribution. A similar antenna constructed at 17 GHz had an input VSWR of < 1.2 at resonance, suggesting that matching presents no further bandwidth problems.

James and Wilson point out that the array results are comparable to those for a slotted waveguide resonant array and the same problems associated with the loading of the feeder line arise with both waveguide and microstrip versions. The losses in the microstrip lines are estimated to be less than 1 dB at 10 and 17 GHz. James and Hall, (15), have extended the comb line concept to travelling wave arrays and have constructed an array having -18 dB sidelobes and an input VSWR < 1.1 with a broadside beam over a 2 1/2% bandwidth.

Resonant arrays operate with a broadside beam. In typical travelling wave arrays, for example the slotted waveguide array of section 4.2.1, the beam position is dependent on frequency and unless the radiating elements are matched will produce a high input VSWR when the beam is at broadside. James and Hall have overcome this problem in the comb line travelling wave array by spacing the fingers by a quarter wavelength. This gives matched pairs of radiating elements and the array produces a broadside beam, with a low input VSWR.

A form of comb line antenna, the zig-zag line has been investigated, (35), as a frequency scanned radiator. The form of this antenna is shown in FIG. 1.17(c). A large electrical length between the elements is obtained by the zig-zag line arrangement. Experiments have confirmed that this long line length results in an antenna that has high losses. No work has been done on the problem of low loss delay lines in microstrip that would be suitable for frequency scanned arrays.

## 1.6 The Chain Antenna

Developed from the concept of the TEM line antenna, (36), the chain antenna, (37), (38), is a radiator in microstrip form that relies on radiation from straight sections of line. The form of a linear chain antenna is shown in FIG. 1.18(a) and essentially consists of two mirror image meander lines placed side by side. Radiation is from the sections of the line parallel to the antenna axis and spaced by a wavelength. Radiation from the line sections perpendicular to the axis is equal but of opposite phase and approximately cancels. The resultant radiation is thus polarised parallel to the antenna axis. The antenna is of the travelling wave type. An array of four of these linear elements is described in which, in addition to the pair of transmission lines which are adjacent becoming a single line, the radiating sections of adjacent linear elements become one line thus forming a grid geometry as shown in FIG. 1.18(b). The array has sidelobes of approximately -10 dB and a beam which is off normal, the elevation angle depending on frequency. As with most travelling wave antennas the VSWR becomes large when the array is operated in a broadside direction. The power dissipated in the load varies also with frequency. However, when operated with the beam about  $10^\circ$  off normal the array dissipates about 2% of the power in the load, has a VSWR of less than 1.1 and a gain of about 25 dB.

This antenna was not originally developed in microstrip form. The meander lines were printed on a dielectric sheet which was supported above the ground plane. In this form the distribution of power down the array can be controlled by varying the height of the lines above the ground plane. The spacings used by Tiuri are such that at frequencies above 10 GHz this antenna could be manufactured in microstrip.

## 1.7 The Serpent Line Antenna

The serpent line is a periodically modulated transmission line placed close to a ground plane. The period of the modulation is such that the radiation from the continuous discontinuity has the correct phase relation to produce a beam which is close to broadside. Trentini, (39), has described such an antenna. The idea and basic theory is derived from that by Rotman and Karas, (40), for the sandwich wire antenna. The sandwich wire antenna is derived from a stripline transmission line whose centre conductor is modulated periodically about the central plane of the stripline system and radiates outwards from the stripline edge. (see section 2.1 on the sandwich wire antenna). The serpent line antenna does not have the parallel conductors on either side and hence cannot be regarded as a sandwich wire radiator. However, it would appear that the design procedure is the same for both types and Trentini obtained, by varying the line modulation to control the antennas' aperture distribution, sidelobe levels of -20 dB. Again, using a travelling wave approach, the antenna could not be operated at broadside. A bandwidth of about 15% has been obtained, but Trentini does not state how much power is lost in the load on the end of the line. The ground plane spacing used by Trentini make this type of antenna suitable for production in microstrip form.

## 1.8 Coplanar Stripline Antennas

A microstrip variant, devised by Wen (41) in 1962 and known in the U.S.A. as coplanar stripline, has recently been applied to resonant radiators. The form of coplanar stripline is shown in Fig 1.19(a). The structure is excited by connecting the inner of the coaxial feed line to the strip and the outer to the ground planes, which are connected together. Thus the fields are confined to the gaps between the strip and the ground plane. The fundamental mode is "pseudo-TEM" and the severe dispersion problems of slot line, (2), are substantially reduced.

Broad line resonant radiators have been constructed in coplanar stripline,(42), and have been shown to have the same fundamental properties as microstrip types, but with much lower levels of cross polarised radiated field. It is also believed that this structure exhibits lower mutual coupling between adjacent lines. A broad line resonant radiator as shown in Fig 1.19(b) has been constructed with a VSWR less than 3:1 over a 6.5% frequency band for a substrate height of about  $\frac{\lambda_m}{60}$ .

#### 1.9 Summary Comment

Although adequate expressions exist for calculating microstrip impedance, the radiation mechanism from the open circuited line and other discontinuities and the surface wave problem have not yet been sufficiently investigated. Broad line resonant radiators, in element and array form, have had numerous applications, whilst narrow line types, having an inherently very narrow bandwidth have not been widely used. Strip radiators also have a very narrow bandwidth but have found application in conformal situations. Non rectangular resonant radiators have not yet been exploited, the problem of feeding them by microstrip lines not having been solved. The comb line array shows promising performance in the resonant and travelling wave mode. The travelling wave comb line operates with a broadside beam unlike the chain antenna and the serpent line antenna. The chain antenna has received little attention and shows no advantages over the comb line array. The serpent line appears to be the microstrip analogue of the sandwich wire antenna (section 2.1) and therefore could, it is believed, be developed into a broad bandwidth linearly polarised array having a broadside beam.

Almost without exception the contributions rely fairly heavily on experimental optimisation and performance obtained falls short of modern requirements with respect to, for example, bandwidth, input VSWR, sidelobe level, and efficiency. There are very few theoretical contributions and these appear in isolation with very little or no experimental backup. In order to improve the performance and generate new configurations a deeper knowledge of the radiation mechanism and how to calculate and control it is required.



## 2. CAVITY BACKED PRINTED ANTENNAS

This section covers antennas that can be printed using standard manufacturing processes, but which will operate successfully with either no ground plane or with the ground plane, used to produce radiation in one direction, placed about a quarter of a wavelength distant. These include the sandwich wire antenna, printed dipoles and various VHF antennas that have been re-investigated at microwave frequencies using printed techniques. A survey of some types of these antennas has been made by Serafim, (43).

### 2.1 The Sandwich Wire Antenna

#### 2.1.1 Theory

The sandwich wire antenna has been analysed by Chen, (44), and latterly by Green and Whitrow, (45). The antenna was first proposed by Rotman and Karas, (46), and described by them as three coplanar conductors as shown in Fig 2.1, the centre one of which undulates in the same plane. It is this undulation which produces the radiation. This arrangement can also be understood as a section of a triplate transmission line. If the centre conductor of such a line is tilted, then a TEM parallel plate mode is generated which will propagate in the direction of the line. If this tilt is made periodic then the TEM mode can be forced to radiate perpendicularly to the line, out of the edge of the triplate section. Radiation from the longitudinal sections of line is effectively cancelled by equal and opposite currents in the outer conductors and only the transverse sections radiate, producing a transversely polarised radiated field. The modulation can take any form; usually triangular, trapezoidal or sinusoidal forms are used.

The analysis consists mainly of determining the attenuation of the current down the line and from that deriving the radiation pattern. The antenna is operated in the travelling wave mode with a matched load on the end. The analysis is performed for the antenna backed by a cavity, as shown in Fig 2.2. This is the configuration adopted for the practical form of the antenna. In order to control the distribution across the radiating aperture the modulation of the centre conductor is modified and the larger the modulation the greater is the radiation.

#### 2.1.2 Practical Antennas

Practical examples of the sandwich wire antenna have been described by Rotman and Karas, (46, 40). The attenuation rate and hence the modulation required to produce the required aperture distribution were determined experimentally as these antennas were developed before the theory was established. Each period of the line was individually matched at the resonant frequency by capacitive stubs placed every half wavelength which cancelled out the reflections from each undulation. Six lines, 5 periods long, fed by a corporate feed, resulted in an array having -20 dB sidelobes and VSWR < 2:1 over a 14% bandwidth. The beam, broadside at resonance, squinted as expected with frequency.

Graham and Dawson (47) have developed this type of antenna and produced an array of 19 sandwich wire lines 18 periods long. The antenna cavities, the walls of which are brought above the level of the line to aid cancellation of the polarisation parallel to the line axis, are bent from aluminium sheet. This produces a lightweight, rugged structure. Designed for -30 dB sidelobe level, -25 dB is achieved over a 40% bandwidth. About 5% of the power is absorbed in the matched loads at the ends of the line and the line loss is about 0.1 dB. This array has a squint of about  $\frac{1}{2}^\circ$  per 100 MHz at X-band. If the antenna is centre fed, as in a typical monopulse radar antenna, (48), then the two halves squint in

opposite directions and the resultant beam is always on broadside, but the radiation pattern is degraded. This monopulse antenna is fed by a folded pillbox, incorporating a parabolic reflector, which provides a uniform phase front across the arrays, and is shown in Fig 2.3.

## 2.2 Printed Dipoles

Printed circuit techniques have been applied to a basic radiating element, the halfwave dipole. Wyatt,(49), has described a single printed dipole element with an omnidirectional pattern fed by an unbalanced line transformer or balun. This was developed to replace a relatively narrow bandwidth folded dipole antenna at VHF. The printed dipole, which had a height to width ratio of  $2\frac{1}{2}$  and had thus a wide bandwidth of 40%, was more rugged and economical to manufacture than the previous design.

Wyatt printed both arms of the dipole on the same side of the substrate and fed them by a line at right angles to the plane of the antenna. Wilkinson,(50), has shown that by printing the arms on each side of the substrate that a parallel transmission line in the plane of the antenna can be used to feed it. This arrangement is shown in Fig 2.4. Wilkinson also describes a printed balun. Using a corporate feed system, he has produced a two dimensional array having 256 elements. The radiating surface is placed a quarter of a wavelength in front of a reflector to produce a beam pointing in one direction only. The aperture has an essentially constant illumination giving -12.5 dB sidelobes and a VSWR < 1.3 over a 5% bandwidth at X-band. The losses in the elements and feed system are about 3dB. A similar type of array is described by Stark,(51).

Printed dipoles have been constructed to integrate with a stripline (triplate) feed system. Such an antenna is described by Hersch,(52), and shown in Fig 2.5. The ground planes of the triplate system are extended to form the two arms of the dipole while the centre conductor is extended to excite the two arms and includes a quarter wave matching system. A pair of these elements, used on an aircraft landing system, produce a pattern which is omnidirectional in the half of the H plane directed away from the triplate system and a VSWR < 1.5 over a 5% bandwidth.

A wideband printed dipole has been described by Dubost et al,(53). The element, a folded dipole with a very wide fed section and a comparatively narrow folded section, is printed on one side of the substrate, whilst the feed line, which contains a matching element is printed on the other. The arrangement is shown in Fig 2.6. The dipole can be operated close to a reflecting surface, with a typical spacing of  $\frac{\lambda_0}{50}$ . One example of the dipole has a VSWR  $\leq 2:1$  over a 21% bandwidth. Placing a dielectric between the dipole and the reflecting surface serves to reduce the antenna size and equalise the E and H plane patterns. The bandwidth of the above example is reduced to 17.5% for a teflon dielectric.

The concept of a printed circuit dipole has been applied to an element which will provide good circular polarisation over a very broad beamwidth. The element consists of the superposition of complementary antennas, the dipole and the slot, to achieve equal E and H plane radiation patterns. This type of element is suitable for use in arrays as its performance is essentially unaltered by the array environment. Although not flat, two interesting examples which illustrate the principles involved are given by Cox and Rupp,(54) and Wasse and Denison,(55). The dipoles are in the form of Fig 2.4 and are placed in the mouth of an open ended wave guide parallel to the broad wave guide dimension. Cox and Rupp report an ellipticity of less than  $\pm 2$  dB over a  $\pm 60^\circ$  beamwidth.

An element similar to that of Dubost has been used within a printed slot to

provide circular polarisation as described by Sidford,(56, 57). The slot and dipole are thus planar and are mounted close (about  $\frac{\lambda_0}{12}$ ) to a reflecting ground plane. The element, shown in Fig 2.7, has a VSWR less than 2:1 over a 10% bandwidth and an axial ratio less than 2 dB over a 5% bandwidth. To force the slot to radiate an orthogonal polarisation to that of the dipole a strip, printed onto the same side of the substrate as the feed line, was used to produce antiphase components in the currents induced in opposite edges of the slot. The element has been used in array form mounted on aircraft fuselage.

It should be noted that the elements of Dubost et al and Sidford are spaced closer than  $\frac{\lambda_0}{4}$  from the reflecting surface. This makes them much thinner than the other types discussed in this Chapter but still thicker than an equivalent microstrip type and more complicated to construct.

### 2.3 Printed Colinear Dipole Arrays

#### 2.3.1 The Franklin Antenna

The Franklin antenna, a well known HF and VHF radiator, has been re-investigated at microwave frequencies using printed circuit techniques. The antenna consists of several colinear halfwave radiators separated by halfwave phase reversing sections which maintain the in phase relation of the currents in the radiating elements. Shown in Fig 2.8(a), and having double stubs to reduce cross polarisation, this antenna is described by Fubini et al,(58). The array is placed  $\frac{\lambda_0}{40}$  above a reflecting surface, and supported by a low loss dielectric slab. A 30 element, centre fed array, having 6 dipoles in each linear array was constructed and found to be very narrow band. The sidelobes of this array were found to be -11 dB in the H plane and -16 dB in the E plane at the resonant frequency. Fubini et al have not attempted to develop this antenna and no other references to it have been found since. It is probable that the line losses in this series type dipole array are less than in a dipole array fed by a corporate feed structure as described in section 2.2, but with the Franklin type broad-banding appears much more difficult.

#### 2.3.2 Capacitively Coupled Colinear Array

In this type of dipole array, shown in Fig 2.8(b), the required phase change between each element is provided by a capacitive gap. The elements are again spaced  $\frac{\lambda_0}{4}$  from a reflecting surface to produce a unidirectional beam. McDonough, (59), describes a 5 x 8 element two dimensional array centre fed from a balanced two wire transmission line. Sidelobe levels are generally between -1 and -19 dB over a 7% bandwidth. Input VSWR is not given. The comments made on the Franklin antenna (section 2.3.1) also apply to this type of antenna.

### 2.4 The Ground Plane Slot Radiator

Yoshimura,(60), has described the radiation properties of a microstrip line terminated on the edge of a slot in the ground plane. The slot will radiate to both sides of the ground plane and to give a unidirectional pattern Yoshimura has placed the element  $\frac{\lambda_0}{4}$  distant from a reflecting surface. The element is shown in Fig 2.9. The matching is determined experimentally and the radiation patterns of the optimum geometry are given. A 4 x 4 element array is constructed at X-band, fed by a corporate feed designed for a -26 dB sidelobe level distribution. Sidelobes of -24 and -22 dBs in the H and E plane respectively are measured. The input

VSWR and bandwidth of this array are not given. As it is necessary to short the transmission line to the slot edge, Yoshimura suggests that where alumina type substrates are used, the slots are fed by slotline. This type of structure is analogous to stripline cavity backed slots although having a thicker profile. Losses are anticipated by the authors to be similar to those of stripline slot antennas and although the shorting pins, characteristic of stripline slots, are absent, production difficulties are foreseen in introducing the shorting strip into the substrate. Slot mutual coupling problems should be similar to those of stripline slot arrays whilst on low sidelobe arrays coupling due to surface waves on the dielectric-air interface could be a problem.

## 2.5 Summary Comments

The sandwich wire antenna is a broad band, low loss antenna having a broad-side beam with low sidelobes. Its construction however is fairly complicated. Printed dipoles have been extensively used where narrow band antennas are required. Their design in element or array form is straightforward apart from the balanced feeding system. The wide band dipole and dipole and slot have good performance but their design is empirical. Arrays of colinear dipoles are narrow band with low line losses due to the absence of a corporate feed system but have no outstanding advantages over other printed antennas. The ground plane slot, which is analogous to the stripline slot, is much thicker than stripline. Not enough work has been done to show whether it has significant advantages.

Cavity backed printed antennas have a thickness dependent on the frequency of operation, but which is considerably greater than microstrip or stripline and are thus not ideally suited for low profile applications. Their performance is now being matched by microstrip and stripline types, except where circular polarisation is required. It should however be noted that printed dipoles have an inherently wider bandwidth than a microstrip antenna giving the same radiation pattern due to much larger radiating area. The sandwich wire antenna, although limited by standard travelling wave antenna constraints, shows significant advantages over other cavity backed printed types.

### 3. STRIPLINE

Stripline (or triplate) is a symmetrical form of transmission line, consisting of two infinite ground planes, between which lies the centre conductor (or strip), as shown in Fig 3.1. This type of line was first proposed in 1951, (61), and due to the high loss of dielectrics then available was conceived in the air spaced form. Except where high powers are to be carried, stripline is now constructed with dielectric between the ground planes. Usually, the dielectric sheets are copper clad on both sides, the required line configuration being etched on one side. A dielectric sheet clad on one side is then bonded to this to form the stripline system. Occasionally, the circuit is double registered, where the circuit is etched on both boards, one being the mirror image of the other. This requires good alignment procedures during bonding and is claimed to make a more symmetrical structure, which reduces coupling to parallel plate modes. This problem is discussed later.

#### 3.1 Theory

##### 3.1.1 Stripline Transmission

Stripline supports a basic TEM wave and if  $h > \frac{\lambda_0}{2}$  some higher order modes. However in most practical stripline circuits higher order modes are not present except at line discontinuities and in calculating the line impedance,  $Z_s$ , and the line wavelength,  $\lambda_s$ , they are ignored. Bates, (62), has solved for  $Z_s$  and  $\lambda_s$  exactly, using a conformal transform method which yields rather complicated expressions. Cohn, (63), has produced simpler approximate solutions which are within 1% of the exact solution for the ranges:

$$\frac{W}{h} \geq 0.35 \left( 1 - \frac{t}{h} \right) \dots\dots\dots 3.1$$

and  $\frac{t}{h} \leq 0.25 \dots\dots\dots 3.2$

where  $t$  is the thickness of the centre conductor. For printed stripline this corresponds to an upper limit of about 120  $\Omega$  line impedance.

##### 3.1.2 Radiation from Stripline Slot

The potential application of this transmission medium to antenna arrays was realised soon after its proposal. Oliner, (64), in 1954 describes an approximate derivation of the conductance of a slot in a ground plane fed symmetrically by a stripline conductor, as shown in Fig 3.2. Oliner uses a variational expression and states that results obtained agree within 10% of those obtained by measurement. Breithaupt, (65), has extended Oliner's expression to include slots excited by an offset line. This is particularly useful when it is required to alter the coupling from the line to the slot. Maximum coupling occurs when the line is centred on the slot. Breithaupt's expressions agree within about 20% of measured values of conductance. Neither Oliner nor Breithaupt calculate the slot susceptance and both assume that the stripline has side walls close to the slot, parallel to the transmission line, spaced such that the rectangular waveguide modes excited by the slot are below cut-off. In the absence of these walls the slot will radiate power back into the line in the parallel plate mode mentioned earlier. In Breithaupt's measurements eyelets were placed around the slot to reduce this effect. In practice some form of device shorting the two ground planes is now always used. This meant that the theoretical analysis can be examined in terms of a cavity backed slot.

## 3.2 Cavity Backed Slots

### 3.2.1 Theory

Cavity backed slots have been analysed by Galejs, (66), and Adams, (67). Galejs obtains the longitudinal voltage distribution across the slot by a variational solution of the integral equations and hence the slot admittance. He shows that the slot may resonate when the voltage along the slot is approximately half a cycle of a sine wave. The resonant cavity depth and antenna beamwidth are examined. Dielectric loading is shown to reduce the cavity depth and antenna beamwidth. Adams, using a similar approach, examines the effect of higher order modes and the introduction of ferrite into the cavity. Lagerlof, (68), has given direction to this analysis by presenting the dimensions of slot and cavity which give the required resonance and optimises the cavity dimensions and dielectric constant of the filling to give the lowest possible Q-factor and hence widest bandwidth.

Two problems still remain which these analyses have not resolved. Firstly, it is assumed that the probe or loop which excites the cavity or slot is very small and that it does not affect the resonance. This, in a practical stripline cavity, is not true. Secondly, the theory assumes that the cavity has solid walls. It is difficult to determine how well the shorting devices now commonly used, for instance rivets, pins or plated through holes, define the cavity.

Lagerlof, (68), has attempted to solve the first problem using a simple transmission line model of the slot. He deduces that the resonant frequency of the cavity is reduced, the reduction being larger for a broad, short slot than for a narrow, long one. He also calculates the change in admittance of the slot due to the presence of the stripline centre conductor and shows that the change is least for very short slots. On the problem of the definition of the cavity, Lagerlof states that the pins should be less than half a wavelength apart to prevent radiation of the unwanted modes. It should be noted that Lagerlof does not present any measured data to verify his calculations and therefore design of cavity backed stripline slots must necessarily remain partly experimental.

### 3.2.2 Practical Stripline Antennas

In order to vary the excitation at the radiating elements of a stripline array, to control the radiation pattern, the slots can be fed by offset lines, the amount of offset determining the coupling to the slot. In addition, the excitation of the line itself can also be controlled.

The first method is used where many slots are to be fed from one transmission line. An example of this is described by Hill and Paul, (70). A linear array of 5 slots is fed by a meandering transmission line. By adjustment of the line, the phase and amplitude of each slot excitation can be controlled. The admittance of the slot is matched out by wide sections in the feed line at each element. The sidelobe level of this array is within 2 dB of that predicted at -20 dB. Squint and loss also agree with values predicted. The efficiency is about 80%. The VSWR is less than 1.3:1 over a 4% bandwidth.

Bazire et al, (71), have produced a 9 x 27 element two dimensional array fed by an offset line series feed system. This is shown diagrammatically in Fig 3.3. Each linear array is of travelling wave type and forms a main beam of the radiation pattern which is squinted off normal. By feeding at any of the four input ports, four beam positions can be obtained. The element design was arrived at experimentally although initial estimates were based on the work of Galejs, (72). The offset feeding method was used to give a  $\cos^2$  aperture distribution in the E plane resulting in sidelobes typically below -25 dB. Input VSWR is better than

1.2 and line losses are less than 0.75 dB. Manufacturing repeatability of this antenna has been found to be within the limits of accuracy required for Doppler navigational radar requirements.

Control of element excitation by variation in line excitation was used by Sommers,(73), in an early 4 x 4 element two dimensional slot array. The element was developed experimentally and pins, eight to each slot, as shown in Fig 3.4, prevented excitation of parallel plate modes. The feed arrangement consists of a parallel (coplanar) feed in the E plane and a series type in the H plane. Mutual coupling between diagonal elements is present which degrades the sidelobe levels to -13 and -9 dB in the H and E planes respectively from -15 and -13 dB for linear H and E plane arrays respectively. The array was designed with a uniform amplitude and phase distribution.

A more recent example,(74), a 32 element array within a circular aperture, has been produced for a monopulse radar application. The element layout is shown in Fig 3.5. Here again, empirical work was required to match the line to the cavity and slot, the admittance of which varies with the line width. The slots are centre fed and the required distribution is obtained by correct design of the power splitters in the feed network. The cavities are formed by through-hole plating, a technique which can now be adequately controlled. This avoids the problem of projections above the surface of the ground plane close to the slot which affect the admittance of the slot. Through hole plating reduces the interelement coupling to negligible levels allowing sidelobe levels within 2 dB of the -25 dB predicted value to be obtained on the sum radiation pattern. The line losses are 0.3 dB. A multilayer triplate construction technique is used in this antenna which, with the integral comparator, minimises the overall depth and reduces spurious radiation from the power dividing network, resulting in excellent cross polarisation performance. This array operates at X-band although a similar array has been produced at J-band.

A comparable array also at X-band is described by Josefsson et al,(75). This array has 52 elements within a circular aperture  $5.5 \lambda_0$  in diameter. The array was designed to have -35 dB sidelobes. After an experimental investigation it was found that mutual coupling effects would only raise the sidelobe level by 1 to 3 dB. Measurements were also made to establish the coupling, inside the stripline structure between the radiating elements. The coupling level is not mentioned but the design used twelve plated through holes per slot. Measurements on the array showed that it had a highest sidelobe level of about -25 dB and an average level of about -35 dB. The VSWR was less than 2.5:1 over a 6% bandwidth and the line losses were about 2 dB.

Fritz and Mayes,(76), have used the stripline slot in a frequency scanned array and have shown how the antenna can be made to scan through broadside without the input VSWR becoming large by individually matching out each element at resonance.

Campbell,(77), has used the stripline slot to produce a very thin omnidirectional antenna which can be easily made to withstand the harsh space environment by coating the outer ground plane with a layer of dielectric.

### 3.3 Periodically Modulated Radiator

An interesting, travelling wave type of radiator can be made using stripline. A long slot is made in the upper ground plane. The centre conductor runs parallel to the slot but is periodically modulated about the centre line of the slot as shown in Fig 3.6. In one design by Laursen,(78), the line is of a trapezoidal form and in another, (78,p3-6), is sinusoidal and the slot tapered. The periodically modulated line, in fact, forms a sandwich wire radiator, the walls of which are formed by plated through holes. This radiator then excites the slot

with a transversely polarised field. In order to obtain the required phase and amplitude along the line, in order to control the radiation pattern, the attenuation and phase constant for a given modulation depth must be known. Laursen describes three methods by which they can be measured, namely the far field method, the near field method and the insertion loss method. These are described in Appendix J. Using experimentally obtained values Laursen applies the theory of Rotman and Karas,(40), to determine the modulation distribution to give an amplitude distribution.

An array of 8 such lines has been constructed at X-band by Laursen. The E plane feed system was designed for equal phase and amplitude and the measured pattern has a -14 dB sidelobe level. The H plane sidelobe level is measured as -15 dB, 3 dB down on the designed level and did not rise above -14 dB over a 30% bandwidth. However the VSWR is less than 1.4 over a bandwidth of 5%. The lines lose between 10 and 15% of the power in matched loads placed on the ends. The main beam is squinted from the normal. About 0.6 dB power is lost in the lines and a further 1.4 dB in a thick dielectric cover over the front. The array could be made to operate with a broadside beam at resonance by placing matching stubs spaced by half a wavelength as is done in the sandwich wire array.

### 3.4 Summary Comments

The transmission mechanism of stripline is now adequately understood but generation of parallel plate modes within the structure from discontinuities has not yet been fully analysed. The theoretical operation and optimisation of the cavity backed slot is well documented; however problems of cavity feeding and cavity formation are not completely solved.

Linear and two dimensional arrays of cavity backed slots have been produced with sidelobe levels of -25 dB over moderate bandwidths. Broad band types, using a continuous slot and periodically modulated feed line operate have so far proved to have a moderate, input impedance controlled, bandwidth. Both types of array have losses between 1 and 2 dB.

The performance of stripline antenna still falls short of equivalent waveguide types in bandwidth, loss, sidelobe level and power handling, but they have a much flatter profile whilst still using presently available manufacturing techniques. The theoretical analysis is not complete and design is still based on empirical methods.



#### 4. WAVEGUIDE FLAT PROFILE ANTENNAS

Waveguide flat profile antennas consist, in general, of several waveguide runs placed parallel to each other, each waveguide run having a series of slots cut in to the wall to form a two dimensional array of slots. A typical arrangement is shown in Fig 4.1. The waveguides are fed serially or in parallel, usually by a further waveguide arrangement. If the array is resonant each waveguide run is terminated by a short circuit; if it is operated in a travelling wave mode each waveguide run is terminated by a device to prevent a reflected wave usually a dissipative matched load. In the plane of the waveguide runs the antenna produces a beam whose angle is dependent on frequency. The angle in the orthogonal plane is frequency independent if a parallel feed system is used. Unless each element is individually matched and this is not usually the case, this type of antenna cannot be operated with a beam normal to the plane of the radiators. This contrasts with arrays of waveguide ends, usually fed by parallel (corporate) feed systems, which produce a broadside beam independent of frequency. A corporate feed system is bulky and this type of antenna has by no means a flat profile. A compact squintless feed has been developed, however, by Rodgers, (79), which is an extension of the compensated series fed type of power divider. A schematic diagram is shown in Fig 4.2. Although the device is a series type of power divider the path length to all radiating elements is equal at all frequencies and hence produces a squintless beam.

##### 4.1 Waveguide Slots

###### 4.1.1 Basic Slot Types

The basic slot types are shown in Fig 4.3 together with their equivalent circuits. Stevenson, (80), has given straightforward expressions for the conductance and resistance of these slot types, using the electromagnetic formulation of Babinet's principle, (81), assuming that the reactive field in the slot which is resonant is zero and that the waveguide walls are very thin. These expressions have been extended by Oliner, (82), by use of variational expressions coupled with stored power considerations, to include the effect of wall thickness, non resonant slots and the reactive part of the slot admittance. Measurements of slot admittance by Cullen, (83), and Dodds and Watson, (84), confirm these expressions for the broad wall longitudinal and narrow wall inclined slots and broad wall longitudinal slot respectively.

###### 4.1.2 Further Slot Types

Special properties can be obtained from combinations of these basic slot types. If two separate slots, one shunt and one series, in the broad wall of a waveguide, arranged to form a T, have a conductance and resistance, respectively, equal to twice the waveguide impedance, then the radiators are matched to the waveguide and no energy passes the slots, (85).

The basic slot type can be loaded to either reduce its physical size at resonance or to ease fabrication. The slots may be loaded with dielectric sheets or plugs or by altering the shape to form a dumbbell or H slot (86) as shown in Fig 4.4.

Hill, (87), has commented that the H slot has several limitations as a narrow wall slot type. If the arms are made long enough to produce a resonant slot, the angular rotation, necessary to alter the coupling, is limited if the limbs are not to intersect the broad wall, as in Fig 4.5. Also the coupling mechanism is

particularly lossy, wasting some 30-40% of the coupled power. Hill has therefore examined the asymmetric I slot which was developed at Imperial College, London, (87, p4), as part of the work in the UK/Plessey Doppler Microwave Landing System antenna design. A typical I slot is shown in Fig 4.6. Slot losses are a few percent over a useful coupling range of -5 to -40 dB. The complete slot can be considered as comprising two skew symmetric halves with a common boundary, formed by the waveguide narrow wall axis. The coupling is varied by altering the asymmetry of the longitudinal slot sections. The design was initially developed empirically and subsequently, using assumptions about the fields in the slots, an analysis developed which allowed design improvements and gave information about mutual coupling.

A longitudinal broad wall slot, centred about the waveguide axis will not radiate as it does not cut any lines of current flow. However it can be made to radiate by disturbing the current flow. Clapp, (88), describes how probes can be used to induce radiation as shown in Fig 4.7(a). The phase of the slot excitation can be reversed by placing the probe on the opposite side of the slot. The probe depth can also be used to control the slot coupling. An asymmetrically placed iris beneath the same type of slot has also been used to induce radiation, as shown in Fig 4.7(b), (89).

A slot element suitable for use in an array is described by Clavin et al, (90). It consists of a waveguide slot with two parasitically excited wires, as shown in Fig 4.8. The wires provide a means of equalising the principal plane patterns and increasing the directivity. The improved element has been shown to reduce interelement mutual coupling by 14 dB.

Circular polarisation can be obtained from waveguide slots by means of a cross slot configuration as shown in Fig 4.9(a), (91). The slots are oriented at  $45^\circ$  to the waveguide axis, and are inherently matched to the waveguide. The coupling is varied by changing the length of the slot and at resonance the slot losses are about 25% of the incident power. The hand of polarisation obtained is determined by the direction of the wave in the guide. Another form of circular polarisation radiator is described by Wilkinson, (92) and is shown in Fig 4.9(b). Here a parasitic dipole which is inclined to the waveguide axis is suspended in the slot. An alternative geometry consists of a fed dipole placed in a parasitic slot. Wilkinson has constructed an example having an ellipticity of less than 1 dB at a single frequency and less than 3 dB with a VSWR of less than 1.8:1 over a 20% bandwidth.

Circular polarisation can also be achieved by placing longitudinal and transverse slots  $\frac{\lambda}{4}$  apart in the broad waveguide wall. It involves, however, having the transverse slot extending beyond the wall edge and into the narrow wall. This is a similar problem to that encountered with inclined slots in the narrow wall and places a limit on the closest spacing obtainable when the waveguides are used in a planar array. Palumbo, (93), has avoided this problem by removing the contiguous separating guide narrow walls of the planar array as shown in Fig 4.10. The slots are excited by an equivalent waveguide operating in a higher order  $TE_{no}$  mode, where n is the number of equivalent waveguides. The array of equivalent waveguides is fed from a transverse waveguide with slot couplers. The complete array is of a resonant type. The array has ellipticity typically less than 3 dB and VSWR less than 1.5 over a 1% bandwidth. The design used standard expressions for the admittance of the longitudinal slots. However, measurements had to be made to find the admittance of this type of transverse slot, which has not been theoretically analysed.

Arbitrary polarisation has been obtained by crossed slots in adjacent walls of a square waveguide by Hougardy and Shanks, (94). The polarisation is controlled

by the relative amplitude of the orthogonal  $TE_{01}$  modes in the waveguide. By using a septum parallel to the waveguide axis in a rectangular waveguide Ajioka et al, (95) have obtained arbitrary polarisation from a crossed slot as shown in Fig 4.11. The polarisation is controlled by the relative phase of the modes in the two halves of the waveguide.

## 4.2 Slot Arrays

### 4.2.1 Linear Arrays

Linear arrays can be made of any of the previously described types of slot radiators. These arrays can be either resonant or travelling wave types. In the former, the end of the waveguide is short circuited so that both the incident and reflected wave produce a broadside beam. The radiating elements are placed  $\frac{\lambda_g}{2}$  apart and are oriented to produce antiphase radiation. This can be achieved, for example in longitudinal broad wall slots, Fig 4.3(a), by placing them alternatively about the broad wall axis, in inclined narrow wall slots, Fig 4.3(d), by alternating the inclination angle or in the I slot, Fig 4.6, by alternating the asymmetry. Provided that the total impedance or admittance of the slots is kept equal to that of the waveguide the coupling of each slot can be varied to allow shaping of the aperture distribution and hence the radiation pattern. The result is a very narrow, input impedance controlled, bandwidth array with an accurately broadside beam, (96). For example a 25 wavelength long array can be designed to have a VSWR of less than 1.4:1 over a 0.25% bandwidth, (97).

The bandwidth can be made larger by spacing the radiating elements at electrical separations slightly different from  $\frac{\lambda_g}{2}$  to give a non-resonant array, (98). The array tends to achieve a stable cycle in which the slot conductance is cancelled by the effect of the spacing, so that the admittance is returned to its starting point. Experimental results, (99), showing how the phase change between slots,  $\beta_g L$ , and the apparent characteristic admittance of the equivalent continuously loaded line change as spacings near resonance are approached, indicate that

$$\left( \frac{G_s}{Y_g} \right)^2 \operatorname{cosec}^2 \beta_g L \leq 0.2$$

where  $G_s$  is the mean slot conductance and  $Y_g$  is the waveguide admittance, is a suitable criterion for practical design purposes; this condition gives a maximum VSWR of about 1.2 with  $\beta_g L$  about  $200^\circ$ . This departure of the phase shift from  $180^\circ$  indicates that the beam emerges at an angle to the normal. Also this angle will change with frequency as  $\beta_g$  changes. As in the resonant array the slot coupling can be varied to control the radiation pattern. In these arrays an appreciable reflected wave must be avoided as it would set up an undesirable lobe on the opposite side of normal to the main beam. To avoid this, these arrays are terminated in a matched load, either dissipative or radiative, with, typically, 5%, (97, 100), of the total power being absorbed in it.

Tang, (89), has described measurements on a series of linear arrays of longitudinal, broad wall, slots placed on the broad wall axis and excited by asymmetrically placed irises. By adjusting the irises to give a -40 dB sidelobe level aperture distribution Tang obtained sidelobes of -33.5 dB. He attributes the rise in sidelobe level to positional errors in the slots and irises.

Oliner and Malech, (101), describe various forms of leaky wave antennas, which radiate continuously along the length of the waveguide. The direction of radiation

of these types of travelling wave linear antennas is limited to about  $10^\circ$  from broadside to about  $10^\circ$  to endfire. A typical example, the continuous waveguide slot, is shown in Fig 4.12.

#### 4.2.2 Two Dimensional Arrays

Arrays of linear antennas can be put together to form flat two dimensional arrays. The waveguides are either fed from a corporate or series structure. There are two problems associated with these types of arrays. The first is mutual coupling between elements, which is present in linear arrays but more pronounced in two dimensional arrays. This effect changes the slot conductance and radiation pattern and hence will degrade the overall array performance unless taken into account, (102). The second problem is second order beams, which occur if the element spacing in any direction is greater than a wavelength, (103). These can be suppressed by choosing an array geometry with close element spacings or by placing baffles between each linear array of elements. Further problems concerned with scanning arrays, such as blindness effects, are discussed in (101). Two dimensional arrays of waveguide slots have been described by McCormick, (104), Hilburn et al, (105) and Stark, (106). McCormick has used longitudinal broad wall slots with the waveguide supporting a higher order TE mode in order to achieve low loss. Arrays with longitudinal broad wall slots are prone to second order beams. Hilburn and Stark both describe arrays of inclined narrow wall slots.

The resonant inclined slot penetrates the broad wall and consequently the mutual coupling of this type of element is high. The element conductances were therefore measured in the presence of other elements, Stark using a 10 x 10 array for the measurements. Hilburn has achieved sidelobes of about -28 dB with a 400 element X-band array having a gain of 23 dB. The efficiency of the elements and feed system is 50 to 60%, including power lost in the matched loads. Hilburn quotes the manufacturing tolerances obtained as 0.001" on slot depth and 0.002" on slot to slot spacing. The array scans from  $5^\circ$  to  $20^\circ$  from boresight over a frequency range of 9.5 to 8.5 GHz.

In order to increase the rate of angular beam scan with frequency evanescent (cut-off) waveguide has been used, (107). Evanescent waveguide is a form of slow wave structure which allows a large phase change to occur between elements conventionally spaced. A scan rate of  $27.6^\circ$  for 1.75% change in frequency has been achieved with a 19 element array.

#### 4.3 Summary Comments

The basic waveguide slot radiator operating in isolation is now adequately understood. The further slot types, although not fully analysed can be modelled sufficiently well using the basic waveguide slot methods to allow design work to proceed and are in fact widely used. Some slot types such as the narrow wall inclined slot and H slot have a lossy coupling mechanism and the I slot has been developed to eliminate this problem. Pin or asymmetrical iris excited slots are useful in eliminating second order beams but have been put to little use, due to their complex construction and the simple expedient of walls for removing these beams. The slot with parasitic wires is an improved array element but could prove costly to apply to large arrays. Crossed slots for circular polarisation also have a lossy coupling mechanism and the combination of transverse and longitudinal slots is more efficient, although empirical work is required in array design.

Resonant linear arrays have been shown to have good performance over narrow bandwidths. The lowest sidelobes, -33.5 dB, found for a waveguide slot array was for a travelling wave type having individually adjustable elements. It therefore appears that producing arrays having sidelobes lower than 30 dB is difficult.

Mutual coupling in two dimensional arrays is understood and can be allowed for in the design procedure and arrays having reasonable performance have been constructed.

Flat profile waveguide arrays are now extensively used and their design is well understood. Their performance can be reasonably easily controlled and, provided a loss free element is chosen, is better than any comparable flat profile type in terms of sidelobe level and losses.

## 5. MANUFACTURING TOLERANCES OF FLAT PROFILE ANTENNAS

In order to know whether an antenna specification can be met by a manufactured product, it is important to know what tolerances can be maintained on each process involved in the manufacture and to know the effect of this tolerance on the ultimate performance of the antenna. As every antenna can be considered to have a planar aperture which has a distribution of fields or currents on it then the problem resolves itself into two distinct areas. Firstly determination of the effect on the radiation pattern of errors in the aperture fields or currents and secondly determination of the effect on the fields or currents of manufacturing errors in the antenna structure. The second problem will embrace the effect of manufacturing errors on input VSWR and antenna losses.

### 5.1 Theory

In general, errors in planar antennas produce changes in the nominal radiation pattern and give rise to a background field. Gilbert and Morgan, (108) have shown that if an excitation is used which maximises the gain, the antenna may be superdirective, in which case the background field will be large unless the excitation is extremely well controlled. They show how the antenna gain may be maximised whilst keeping the background field at a constant level.

Elliott, (109) has considered random errors in both the position (translational and rotational) and excitation (amplitude and phase) of elements in an idealised array. He shows that translational errors are dominant and gives an expression relating sidelobe level to translational error. Using a 24 element linear dipole array with a standard deviation,  $\sigma$ , of  $0.05 \lambda_0$  in all three dimensions of position as an example, the design and achievable sidelobe levels are as follows:

Sidelobe Level	
Design, dB	Achievable, dB
20	19.8
30	28.5
40	34

Elliot also shows that the changes in the radiation pattern are reduced as the array size is increased.

The gain reduction and background field have been calculated for excitation phase errors, (110), and positional errors in linear arrays for several different error distributions and is shown to be greater for a uniform type than for a tapered one.

Leichter, (111) and Rondinelli, (112) have shown that random excitation errors can also produce beam pointing errors. Leichter identifies phase errors as the predominant type of excitation error. These analyses have used a discrete approach to the array tolerance problem. Bates, (113), Cheng, (114) and Bracewell, (115) have used a continuous aperture approach, which has application to reflector antennas

as well as arrays. Bates shows that the sidelobe change is a more significant effect than gain reduction and points out that some measure of the average value of the errors is more important than their maximum magnitude. Bracewell points out that whereas in a manufacturing process maximum limits are placed on a parameter, it is usually more useful to specify the mean square error, although this is dependent on the process used which in turn determines the error distribution.

### 5.2 Practical Examples - Waveguide Arrays

Work on the performance degradation in practical antennas due to manufacturing errors are limited solely to waveguide types.

Bailin and Erlich, (116), have analysed the linear shunt slot array. They assume a normal distribution of errors in slot length, slot spacing and slot distance from the waveguide wall axis with a standard deviation of 0.002" at X-band. They show that these errors cause the computed sidelobe level to rise; and on a 24 element array, the probability of the sidelobe level being greater than that given below for given design values is about 16%.

Sidelobe Level	
Design, dB	Achievable, dB
20	19
30	27
40	32

Measurements on arrays manufactured to these tolerances give sidelobe levels which agree essentially with these values. The authors therefore recommend that the antenna is accordingly over designed so that the required sidelobe level can be achieved.

O'Neill and Bailin, (117), have extended this work, by assuming a truncated normal error distribution which they suggest is a form more fitting manufacturing processes. They have produced nomographs of sidelobe level against error standard deviation.

### 5.3 Practical Examples - Printed Arrays

Little published work is available on the effect of material and manufacturing tolerances in printed array antennas. It was felt useful therefore to include experience gained by the authors in this area whilst developing the microstrip comb line array.

There are four main areas of difficulty in the manufacture of printed antennas:

1. Material parameter accuracy.
2. Accuracy of the processes used for etching the circuit on the substrate.
3. If assembly is necessary, as in stripline, accuracy of assembly procedures.
4. Stability of the resultant antenna with time and environmental conditions.

Microwave antennas are in general manufactured on low dielectric constant substrate material having  $\epsilon_d$  between 2.3 and 2.7. These materials are either irradiated polyolefin, polyphenylene oxide, cross linked polystyrene or polytetrafluoroethylene possibly reinforced with either glass cloth or fibre.

A typical low cost substrate, Tellite 3B, (118), an irradiated polyolefin, has a dielectric constant of  $2.32 \pm 0.01$  up to 30 GHz. The tolerance on the dielectric thickness is  $\pm 0.002$ ". This results in, for example for a 50  $\Omega$  line on  $\frac{1}{16}$ " thick material, an uncertainty in line impedance of  $\pm 0.1\%$  and  $\pm 0.3\%$  respectively.

The accuracy of the etched circuit depends largely upon the nature of the process and how well it is controlled. However it is generally recognised that, without special precautions, an accuracy which is approximately equal to the copper thickness can be obtained. This accuracy can be severely degraded if there are lines of widely varying width on one board. Table 5.3 gives percentage errors in line impedance for 70  $\Omega$  and 150  $\Omega$  line in both microstrip and stripline. Although the errors here are small it should be noted that etch accuracy is very difficult to maintain on the travelling wave comb-line array section 1.6 and Fig 1.17, which has fingers with widths varying from 0.1 mm to 2.0 mm. Indeed, fingers thinner than 0.1 mm are completely etched off before the rest of the antenna is etched. This limit on the thinnest allowable line severely limits the lowest sidelobe level which can be achieved. For example the computed sidelobe level falls from -36 dB to -28 dB if the thinnest allowable line is raised from 0.07 mm to 0.14 mm, for a 100 element array.

Assembly accuracy is especially important on stripline slot arrays and is one of the reasons for their high cost compared to microstrip, where the only accurate assembly needed is at the microstrip to coax line transition.

Petrie and Grove, (119), have examined the dimension stability of the materials listed above. They state that dimensional instability is due to the relieving of the internal stresses produced in the material during heat and pressure bonding of the copper to the dielectric. When the copper is etched from one side the stress relief causes the material to shrink and bend. The bending is only significant in that it means special precautions are necessary during processing and that mechanical means are required to flatten it during operation. When the etched material is aged at elevated temperatures further shrinkage occurs. The degree of shrinkage is shown in Table 5.3 for irradiated polyolefin, which is the most unstable of all the materials tested. The premium paid for better stability include higher material cost, greater weight or increased loss factor. Table 5.3 gives the percentage changes in impedance for 70  $\Omega$  and 150  $\Omega$  lines in microstrip and stripline. Petrie and Grove also discuss pretreatment to reduce material instability and show that thermal shock treatments at low temperatures can be effective.

#### 5.4 Summary Comments

Of the two problem areas mentioned in the introduction to this section, only the first, namely determining the effect on the radiation pattern of errors in the aperture distribution, has received sufficient attention. It has usually been left up to the engineer to solve the second problem, determining what manufacturing tolerances he must specify in order to obtain the required performance from any particular antenna. Indeed it is difficult to generalise on this problem as each antenna has different tolerance requirements. However, it is worthwhile to examine the problem, especially for printed antennas where no published material is available, as over-specification of manufacturing tolerances can be both wasteful of manpower and expensive.



## 6. CONCLUSIONS

Flat profile antennas are a class of antennas which are designed for applications where their thin profile is a primary requirement. Further requirements can be generalised as follows:

1. Broadside beam.
2. Low sidelobes.
3. Any polarisation.
4. Wide bandwidth operation.
5. Low input VSWR.
6. High efficiency (including aperture efficiency and losses).
7. High power handling.

Other requirements, related to specific applications, are:

1. Narrow or multiple bandwidth.
2. Shaped or multiple beams.
3. Beam scanning.

These have not been covered in depth in this survey and will therefore not be commented on.

It should be noted that not necessarily all the general requirements will be needed for any one application. Also that all these requirements are not possessed by any one antenna. This is particularly true of flat profile types and it is important to stress the fundamental capabilities and trade-offs involved in flat profile antennas.

Considering the whole field of flat profile antennas and examining travelling wave types as being capable of the broadest bandwidth the following capabilities have been shown to date:

- a. Broadside beam only at one frequency and low sidelobes using an end fed system, or
- b. Wide band broadside beam with degraded radiation pattern using a centre fed system.
- c. Any polarisation dependent on radiating element.
- d. Low input VSWR if each radiating element or pair is matched.
- e. High efficiency or low sidelobes.
- f. Power handling dependent on antenna type.

Capabilities a. and b. are peculiar to flat travelling wave type antennas. Capability e. is a fundamental antenna limitation implying that to obtain low

sidelobes the antenna aperture distribution must be tapered smoothly at the aperture edges which in turn involves increasing the aperture size to maintain constant directivity. Whether constant gain is also maintained depends on the antenna losses. As the most efficient distribution is uniform, low sidelobes must involve some loss of efficiency.

In travelling wave antennas there is a limit to the sidelobe level which can be obtained. This is due to limits on the maximum power that can be removed from the transmission line by any radiating element, which depends on the elements geometry, and the minimum power, which is dependent on manufacturing tolerances. These two limit the maximum aperture taper. Manufacturing tolerances also introduce amplitude and phase errors into the distribution which limit the lowest obtainable sidelobe level.

In order to compare the achieved performance of each type of antenna, these have been brought together in Table 6.1. Each set of performance figures are for a representative member of each type and show typical performance achieved to date. It can be seen that it is impossible to select an antenna type which has the best overall performance, each has to be judged on the required application. Also that the performance depends on the amount of design work and analysis that has been performed.

It can be stated however that microstrip antennas fall short of modern requirements, as do stripline and cavity backed printed types particularly with regard to bandwidth, and that waveguide slot antennas exhibit the best performance, particularly with regard to low sidelobe level.

In comparing antenna types it is useful to examine the advantages of each particular type from every viewpoint. Table 6.2, given at the end of this chapter, shows the advantages and disadvantages of the four classes of antenna, microstrip, cavity backed printed, stripline and waveguide.

The remaining problem areas in the four classes of antennas are as follows:

1. Microstrip Antennas      A complete analysis of the mode of operation of the various types of microstrip antennas is needed. This will allow full utilisation of the possible performance of the antenna form. The bandwidth of microstrip antennas can be extended by using a travelling wave form. The performance of the existing types, comb line, serpent line and the chain should be improved and extending them to circular polarisation investigated.
2. Cavity Backed Printed Antennas      The sandwich wire antenna needs further investigation to allow its design to move from the empirical to the analytical. Further work needs to be done to simplify its construction if it is to compete with microstrip types.
3. Stripline Antennas      Analysis of the operation of heavily loaded cavity backed slots is still not adequate to allow simple array design. Work also needs to be undertaken on the suppression of unwanted modes in the structure if the performance of these antennas is to be significantly improved.
4. Waveguide Antennas      Much work has been done on waveguide slots and the problems now mainly lie in the area of large arrays, that is to say finiteness effects, blind spots in scanning arrays, beam forming and multiple frequency types.

In general, for all four classes of antennas there exist the problems associated with array formation and use, as described for the waveguide types.

There also exists the tolerance problem, which has been examined for an ideal antenna, but has not been investigated thoroughly for each particular class. In particular, a study of the tolerance effects in printed antennas is needed.

7. ACKNOWLEDGEMENTS

The authors would like to thank Dr G N Taylor (Royal Signals and Radar Establishment, Malvern), for initially suggesting this survey and for subsequent helpful discussions and comments.

The following are also thanked for providing useful information and references:

W.L. Jones and T. S. Moore : Marconi Space and Defence Systems Ltd, Stanmore  
Middlesex.  
R. Graham and M.F. Doyle : Marconi-Elliott Avionic Systems Ltd, Borehamwood,  
Herts.  
M. Chambers and D.R. Hill : Plessey Company Ltd, Cowes, IOW.  
J. Mark : Marconi Research Labs, Chelmsford Essex.  
J. E. Summers )  
J. T. Christie )  
J. M. Skinner ) : RSRE Malvern.  
R. H. Garnham )  
A. M. Munro )

8. REFERENCES

1. Greig, D.D. and Englemann, H.F. 'Microstrip - A New Transmission Technique for the Kilomegacycle Range'. Proc IRE, 40, 1644-1650 (Dec 1952).
2. Gunson, M.A.R. 'Microwave Transmission - Line Impedance Data', Von Nostrand Reinhold Company, 58-60 (London 1972).
3. Wheeler, H.A. 'Transmission Line Properties of Parallel Strips separated by a Dielectric Sheet'. IEEE Trans, MTT-13, 172-185, (March 1965).
4. Hammerstad, E.O. 'Equations for Microstrip Circuit Design', Proc 5th European Microwave Conference, Hamburg, 268-272, (1975).
5. Owens, R.P. 'Accurate Analytical Determination of Quasi-static Microstrip Line Parameters', Radio & Electrical Engineering, 46, No 7, 360-364, (July 1976).
6. Hartwig, C.P., Masse, D. and Pucel, R.A. 'Frequency Dependent Behaviour of Microstrip', Dig. Internat. Microwave Symp. PGMTT, 110-116, (1969).
7. Schmitt, H.J. and Sarges, K.H. 'Wave Propagation in Microstrip', Nachrichtentech Z., No 5, 260-264, (1971).
8. Hammerstad, E.O. and Bekkadel, F. 'Microstrip Handbook', The Electronic Research Laboratory, The University of Trondheim - The Norwegian Institute of Technology, Trondheim, Norway, Elab Report STF44 A74169 (Feb 1975).
9. Lewin, L. 'Radiation from Discontinuities in Stripline', IEE Monograph No 358E, 163-170, (Feb 1960).
10. Easter, B. and Roberts, J. 'Radiation from Half-Wavelength Open Circuit Microstrip Resonators', Electron. Lett., 6, 573-574, (Aug 7, 1970).
11. Watkins J. 'Radiation Loss from Open Circuited Dielectric Resonators', IEEE Trans MTT 21, 636-639, (Oct 1973).

12. Watkins, J. and Mirghani, H. 'Radiation Loss from Open Circuit Rectangular Dielectric Resonators operating in Double Integer Mode', Int. J. Electronics, 37, No 5, 689-703, (1974).
13. James, J.R. and Wilson, G.J. 'Radiation Characteristics of Stripline Antennas', Proc 4th European Microwave Conference, Montreux, 484-488, (Sept 1974).
14. James, J.R. and Wilson, G.J. 'Microstrip Antennas and Arrays, Part I Fundamental Action and Limitations', To be published.
15. James, J.R. and Hall, P.S. 'Microstrip Antennas and Arrays, Part II New Array Design Techniques', To be published.
16. James, J.R. and Wilson, G.J. 'New Design Techniques for Microstrip Antenna Arrays', Proc 5th European Microwave Conference, Hamburg, 102-106, (Sept 1975).
17. Sobol, H. 'Radiation Conductance of Open-Circuit Microstrip', IEEE Trans, MTT-19, No 11, 885-887, (Nov 1971).
18. Kompa, G. 'Approximate Calculation of Radiation from Open Ended Wide Microstrip Line', Electron. Lett., 12 222-224, (April 1976).
19. James, J.R. and Ladbroke, P.H. 'Surface Wave Phenomena Associated with Open Circuit Stripline Terminations'. Electron. Lett., 9, 570-571, (Nov 1973).
20. EMI-Varian 'Printed Antennae 2 to 36 GHz; Microwave Front Ends 8 to 30 GHz', Sales leaflet, EMI-Varian Ltd, 248 Blyth Road, Hayes, Middlesex, UB3 1HR, England.
21. EMI Ltd 'Improvements Relating to Aerial Arrangements', British Provisional Specification, 1294024, (28 April 1970).
22. James, J.R. and Wilson, G.J. Royal Military College of Science, Shrivenham, Swindon, Wilts., Private Communication.
23. Howell, J.Q. 'Microstrip Antennas', IEEE Trans, AP-23, No 1, 90-93, (Jan 1975).
24. Derneryd, A.G. 'Linear Microstrip Array Antennas', Chalmers University of Technology, Gothenburg, Sweden, TR 7505, (Oct 1975).
25. Derneryd, A.G. 'Microstrip Array Antenna', 6th European Microwave Conference, Rome, 339-343, (14th-17th Sept 1976).
26. Munson, R.E. 'Conformal Microstrip Antennas and Microstrip Phased Arrays', IEEE Trans, AP-22, No 1, 74-78, (Jan 1974).
27. Sanford, G.G. and Klein, L. 'Development and Test of a Conformal Microstrip Airborne Phased Array for use with the ATS-6 Satellite', IEE International Conference on Antennas for Aircraft and Spacecraft, London, 115-122, (June 1975).

28. Ostwald, L.T. and Garvin, C.W. 'Microstrip Command and Telemetry Antennas for Communications and Technology Satellites', IEE International Conference on Antennas for Aircraft and Spacecraft, London, 217-222 (June 1975).
29. Sanford, G.G. and Munson R.E. 'Conformal VHF Antenna for the Apollo-Soyuz Test Project', IEE International Conference on Antennas for Aircraft and Spacecraft, London 130-135, (June 1975).
30. Byron, E.V. 'A New Flush Mounted Antenna Element', Phased Array Antennas, Proceedings of the 1970 Phased Array Antenna Symposium, 187-192, (1972).
31. Colling, R.H.P. Patent Application No 807303 (14 Mar 1969).
32. Brain, D.J. and Mark, J.R. 'The Disc Antenna - A Possible L Band Aircraft Antenna', IEE Conference Publication No 95, Satellite Systems for Mobile Communications and Surveillance, 14-16, (March 1973).
33. Irish, R.T. 'Elliptic Resonator and its use in Micro Circuit Systems', Electron Lett., 7, 149-150, (April 8th 1971).
34. James, J.R. and Wilson G.J. Royal Military College of Science, Shrivenham, Swindon, Wilts. Private Communication.
35. Aitken, J. Royal Military College of Science, Shrivenham, Swindon, Wilts. Private Communication.
36. Agrawal, P.K. Richards, G.A. Theile, G.A. and Richmond, J.H. 'Analysis and Design of TEM Line Antennas', IEEE Trans, AP-20, 561-568, (Sept 1972).
37. Tiuri, M. Tallqvist, S. and Urpo, S. 'The Chain Antenna', IEEE/AP-S International Symposium, Atlanta, Georgia, 274-277, (June 1974).
38. Tiuri, M. Henriksson, J. and Tallqvist, S. 'Printed Circuit Radio Link Antenna', 6th European Microwave Conference, Rome, 280-282, (Sept 1976).
39. Trentini, Von G. 'Flachantenne Mit Periodisch Gebogenem Leiter', Frequenz, 14, No 7, 230-243, (1960) (In German).
40. Rotman, W. and Karas, N. 'Printed Circuit Radiators; The Sandwich Wire Antenna', Microwave Jnl., 2, 29-33, (Aug 1959).
41. Wen, C.P. 'Coplanar Waveguide: A Surface Strip Transmission Line suitable for Nonreciprocal Gyromagnetic Device Applications', IEEE Trans, MTT-17, No 12, 1087-1090, (Dec 1969).
42. Greisir, J.W. 'Coplanar Stripline Antenna', Microwave Journal, 19, 47-49, (Oct 1976).

43. Serafim, G.R.S. 'A Survey of Printed Antennas', Standard Telecommunications Laboratories Ltd. (Sept 1966).
44. Chen, K.M. 'The Sandwich Wire Antenna', IEEE Trans, AP-10, 159-164, (March 1962).
45. Green, H.E. and Whitrow, J.L. 'Analysis of Sandwich Wire Antennas', IEEE Trans., AP-19, 600-605, (Sept 1971).
46. Rotman, W. and Karas, N. 'The Sandwich Wire Antenna: A New Type of Microwave Line Source Radiator', IRE National Convention Record, 5, Part 1, 166-172, (March 1957).
47. Graham, R. and Dawson, C. 'A Sandwich Wire Aerial', European Microwave Conference, 528-531 (1969).
48. Graham, R. Doyle, M.F. and Alexander, S.J. 'Monopulse Aerials for Airborne Radars', 4th European Microwave Conference, Montreux, 362-366 (1974).
49. Wyatt, J.E.G. 'A Printed Circuit Antenna in the VHF Band', ASWE Technical Report TR-72-34, (April 1972).
50. Wilkinson, W.C. 'A Class of Printed Circuit Antennas', IEEE/AP-S, International Symposium, Atlanta, Georgia, 270-273, (June 1974).
51. Stark, L. 'Comparison of Array Element Types', Proc. 1970 Phase Array Symposium, 'Phased Array Antennas', Ed. Oliner, A.A. and Knittel, G.H., 51-66, (Artech House, Inc 1972).
52. Hersch, W. 'Very Slim High Gain Printed Circuit Microwave Antenna for Airborne Blind Landing Aid', AGARD, Conf. Proc. No 139, 'Antennas for Avionics', Munich, Germany, 26-30 Nov., 1973.
53. Dubost, G. Nicolas, M. and Havot, H. 'Theory and Applications of Broadband Microstrip Antennas', 6th European Microwave Conference, Rome 275-279, (Sept 1976).
54. Cox, R.M. and Rupp, W.E. 'A Circularly Polarised Array Element', IEEE Trans, AP-18, No 6, 804-807, (Nov 1970).
55. Wasse, M.P. and Denison, E. 'An Array of Pulsed X-Band Microstrip Gunn Diode Transmitters with Temperature Stabilisation', IEEE Trans, MTT-19, No 7, 616-622, (1971).
56. Sidford, M.J. 'A Radiating Element Giving Circularly Polarised Radiation over a Large Solid Angle', IEE Conference on Satellite Systems for Mobile Communications and Surveillance', Conf. Pub. No 95, 18-25, (March 1973).
57. Sidford, M.J. 'Performance of an L-Band Aerosat Antenna System for Aircraft', IEE Conference on Antennas for Aircraft and Spacecraft, London, IEE Conf. Pub. No 123-129, (June 1975).



58. Fubini, E.G.  
McDonough, J.A. and  
Malech, R. 'Stripline Radiators', IRE National Convention  
Record, 3, 51-55 (1955).
59. McDonough, J.A.  
Malech, R. and  
Kowalsky, J. 'Recent Developments in the Study of Printed  
Antennas', IRE National Convention Records, 5  
Part 1, 173-176, (1957).
60. Yoshimura, Y. 'A Microstripline Slot Antenna', IEEE Trans.,  
MTT-20, 760-762, (Nov 1972).
61. Barrett, R.M. and  
Barnes, M.H. 'Microwave Printed Circuits', Radio TV News, 46,  
16, (1951).
62. Bates, R.H.T. 'Characteristic Impedance of Shielded Slab Line',  
IRE Trans., MTT-4, 28-33, (Jan 1956).
63. Cohn, S.B. 'Characteristic Impedance of Shielded-Strip  
Transmission Line', IRE Trans., MTT-2, 52-55,  
(July 1954).
64. Oliner, A.A. 'The Radiation Conductance of a Series Slot in  
Strip Transmission Line', IRE National Convention  
Record, 2, Part 8, pp 89-90, (1954).
65. Breithaupt, R.W. 'Conductance Data for Offset Series Slots in  
Stripline', IEEE Trans., MTT-16, 969-970,  
(Nov 1968).
66. Galejs, J. 'Admittance of a Rectangular Slot which is Backed  
by a Rectangular Cavity', IEEE Trans., AP-11,  
119-126, (Mar 1963).
67. Adams, A.T. 'Flush Mounted Rectangular Cavity Slot Antennas;  
Theory and Design'. IEEE Trans., AP-15, 342-351,  
(May 1967).
68. Lagerlof, R.O.E. 'Optimisation of Cavities for Slot Antennas',  
Microwave Journal, 16, 12C-12F, (October 1973).
69. Lagerlof, R.O.E. 'Design of Cavity Backed Slot Antennas and some  
other Related Microwave Components', Technical  
Report 34, Chalmers University of Technology,  
Gothenburg, (1973).
70. Hill, R. and  
Paul, D.H. 'A Rapid Versatile Method of Designing Printed  
Stripline Aerial Arrays', Mullard Research  
Laboratories Annual Review, 36-37, (1975).
71. Bazire, T.W.  
Croydon, R. and  
Cary, R.H.J. 'A Printed Antenna/Radome (RADANT) for Airborne  
Doppler Navigational Radar', IEE Conference on  
Antennas for Aircraft and Spacecraft, London,  
(June 1975), IEE Conf. Pub. No 128, 35-40.
72. Galejs, J. 'Excitation of Slots in a Conducting Screen above  
a Lossy Dielectric Half Space', IRE Trans.,  
AP-10, 436-443, (July 1962).

73. Sommers, D.J. 'Slot Array Employing Photo-Etched Tri-Plate Transmission Line', IRE Trans., MTT-3, 157-162, (March 1955).
74. Jones, W.L. and Moore, T.S. Marconi Space and Defence Systems Ltd., The Grove, Warren Lane, Stanmore, Middlesex, HA7 4LY, (private communication).
75. Josefsson, L. Moeschlin, L. and Svensson, T. 'A Stripline Flat Plate Antenna with Low Sidelobes', IEEE/AP-S, International Symposium, Atlanta, Georgia, 282-285, (June 10-12, 1974).
76. Fritz, W.A. and Mayes, P.E. 'A Frequency-Scanning, Stripline-Fed Periodic Slot Array', IEEE/AP-S, International Symposium, Atlanta, Georgia, 278-281, (June 10-12 1974)
77. Campbell, J.G. 'An Extremely Thin Omnidirectional Microwave Antenna Array for Spacecraft Applications', NASA Technical Note D-5539, (Nov 1969).
78. Laursen, F. 'Design of Periodically Modulated Tri-Plate Antennas', Proceedings AGARD Conf., 26th Avionics Panel Meeting, Munich, 3-1 to 3-5, (26-30 Nov 1973).
79. Rodgers, A. 'Wideband Squintless Linear Arrays', The Marconi Review, XXXV, no 187, 221-243, (Fourth Quarter 1972).
80. Stevenson, A.F. 'Theory of Slots in Rectangular Waveguides', Journal of Applied Physics, 19, p24, 1948.
81. Booker, H.G. 'Slot Aerials and their Relation to Complementary Wire Aerials', J. IEE, 93, Part IIIA, No 4, p 620 1946.
82. Oliner, A.A. 'The Impedance Properties of Narrow Radiating Slots in the Broad Face of Rectangular Waveguides Parts I & II', IRE Trans., AP-5, p4, (1957).
83. Cullen, A.L. 'The Characteristics of some Slot Radiators in Rectangular Waveguides', Royal Aircraft Establishment, Farnborough, Hants, Tech. Note. No. Rad. 200.
84. Dodds, J.W. and Watson, W.H. 'Frequency Characteristics of Slots', McGill University, Montreal, Quebec, Canada, Report No PRA-108.
85. Harvey, A.F. 'Microwave Engineering', 634-635, Academic Press (London 1963).
86. Oliner, A.A. and Malech, R.G. 'Radiating Elements and Mutual Coupling', p111, 'Microwave Scanning Antennas', Vol II, Ed. by R.C. Hansen, Academic Press, (London 1966)
87. Hill, D.R. 'Commutated Doppler M.L.S. Azimuth Array Feasibility Demonstration Model - First Interim Report', UK/MLS 2A/PIW/9, (20 May 1974), The Plessey Company Ltd, Southleigh Park House, Eastleigh Road, Havant Hampshire PO9 2PE.

88. Clapp, R.E. 'The Probe Fed Slots as Radiating Elements in Linear Arrays', Radiation Laboratory, Massachusetts Institute of Technology, Report No 455, (Jan 25, 1944).
89. Tang, R. 'A Slot with Variable Coupling and its Application to a Linear Array', IRE Trans., AP-8, 97, (1960).
90. Clavin, A.  
Huebner, D.A. and  
Kilburg, F.J. 'An Improved Element for use in Array Antennas', IEEE Trans., AP-22, No 6, 521-526, (July 1974).
91. Simmons, A.J. 'Circularly Polarised Slot Radiators', IRE Trans., AP-5, 31, (1957).
92. Wilkinson, E.J. 'A Circularly Polarised Slot Antenna', Microwave Journal, 4, No 3, 97, (1961).
93. Palumbo, B. 'Circularly Polarised L-Band Planar Array for Aeronautical Satellite Use', 6th European Microwave Conference, Rome, 22-1 to 22-15, (Sept 1976).
94. Hougardy, H.H. and  
Shanks, H.E. 'Arbitrary Polarised Slot Array', 1958 IRE WESCON Convention Record, Part 1, 157-160, (Aug 1958).
95. Ajioka, J.S.  
Joe, D.M.  
Tang, R. and  
Wong, N.S. 'Investigation of Characteristics and Practical Implementation of Arbitrary Polarised Radiators in Slot Arrays', 6th European Microwave Conference, Rome, 42-1 to 42-14, (Sept 1976).
96. Silver, S. 'Microwave Antenna Theory and Design', 321-327 Dover Publications Inc., New York, (1965).
97. Ref 85, 636-637.
98. Tricaud, J.B. 'Application of Array Theory to Non Resonant Slotted Waveguides', Onde Elect., 31, 122 and 188 (1951).
99. Fry, D.W. and  
Goward, F.K. 'Aerials for Centimetre Wavelength', University Press, Cambridge, (1950).
100. Ref 85, 329.
101. Ref 86, 137.
102. Knittel, G.H. 'Design of Radiating Elements for Large Planar Arrays: Accomplishments and Remaining Challenges', Microwave Journal, 15, 27-28, 30, 32, 34, 80, (Sept 1972).
103. Kurtz, L.A. and  
Yee, J.S. 'Second Order Beams of Two Dimensional Arrays', IRE Trans., AP-5, 856, (Oct 1957).
104. McCormick, G.C. 'A Two Dimensional Slotted Array', IRE Trans., AP-6, 26-35, (Jan 1958).

105. Hilburn, J.L.                    'Frequency Scanned X-Band Waveguide Arrays',  
Kinney, R.A.                    IEEE Trans., AP-20, No 4, 507-508, (July 1972).  
Emmett, R.W. and  
Prestwood, F.H.
106. Ref 51, 63-65.
107. Craven, G.F. and                'Waveguide Antenna', British Patent Specification  
Hockham, G.A.                    No 1409749 (15 Oct, 1975).
108. Gilbert, E.N. and                'Optimum Design of Directive Antenna Arrays  
Morgan, S.P.                    subject to Random Variations', Bell System  
Tech Jnl, 34, 637-663, (1955).
109. Elliott, R.S.                    'Mechanical and Electrical Tolerances for Two  
Dimensional Scanning Arrays', IRE Trans., AP-6,  
114-120, (Jan 1959).
110. RCRDC Sub Committee on Microwave Components and Techniques 'Aerial  
Tolerances', Chapter 2, Part I, Issue 3, Ministry of Defence (Aviation  
Supply), London, (August 1971).
111. Leichter, M.                    'Beam Pointing Errors in Long Line Sources',  
IRE Trans., AP-8, 268-275, (May 1960).
112. Rondinelli, L.A.                'Effects of Random Errors on the Performance of  
Antenna Arrays of Many Elements', IRE Nat. Conv.  
Rec., 7, Part I, 174, (1959).
113. Bates, R.H.T.                    'Random Errors in Aperture Distributions',  
IRE Trans., AP-7, 369, (1959).
114. Cheng, D.K.                    'Effect of Arbitrary Phase Errors on the Gain and  
Bandwidth Characteristics of Radiation Pattern',  
IRE Trans., AP-3, No 3, 145-147, (July 1955).
115. Bracewell, R.N.                'Tolerance Theory of Large Antennas', IRE Trans.,  
AP-9, No 1, 49-58, (Jan 1961).
116. Bailin, L.L. and                'Factors Affecting the Performance of Linear  
Ehrlich, M.J.                    Arrays', Proc IRE, 41, 235-241, (1953).
117. O'Neill, H.F. and                'Further Factors Affecting the Performance of  
Bailin, L.L.                    Linear Arrays', IRE Trans., PGAP-4, 93-102, (Nov 1952).
118. Tellite 3B Copper-Clad Laminate. Tellite Corporation, 17 Lennox Road,  
Summit, New Jersey 07901.
119. Petrie, E.M. and                'Dimensional Stability of Stripline Materials',  
Grove, R.                    Procs. 10th Elect. Insul. Conf., Chicago Sept 1971,  
Published by IEEE, New York 1971, 179-183.
120. Jacobsen, J.                    'Analytical, Numerical and Experimental Investigation  
of Guided Waves on a Periodically Strip-Loaded  
Dielectric Slab', IEEE Trans., AP-18, 379-388,  
(May 1970).
121. Montgomery, C.G.                'Technique of Microwave Measurements', MIT  
Radiation Lab, Series, 11, McGraw-Hill, New York,  
1948.

9. LIST OF SYMBOLS

General:

$\epsilon_0$  Dielectric constant of free space  
 $\lambda_0$  Wavelength in free space

Microstrip:

$\epsilon_d$  Dielectric constant of substrate  
 $\epsilon_{eff}$  Effective dielectric constant of microstrip line  
 $\lambda_m$  Wavelength in microstrip  
 $Z_m$  Microstrip impedance  
 $w$  Width of microstrip line)  
 $h$  Height of substrate ) See Fig 1.2  
 $Y_e$  End admittance of open circuit microstrip line  
 $G_e$  End conductance of open circuit microstrip line  
 $B_e$  End susceptance of open circuit microstrip line  
 $w_1$ )  
 $w_2$ ) Dimensions of circularly polarised resonant radiator.  
 $\Delta = \frac{w_1 - w_2}{2}$   
 $K$ )  
 $q$ ) Constants used in determination of  $G_e$

Stripline:

$\lambda_s$  Wavelength in stripline  
 $Z_s$  Stripline impedance  
 $w$  Strip width )  
 $h$  Ground plane spacing) See Fig 3.1  
 $t$  Thickness of centre conductor

**Waveguide:**

$\lambda_g$	Wavelength in waveguide
$\beta_g$	Phase constant in waveguide
L	Distance between slots
$G_s$	Mean slot conductance
$Y_g$	Waveguide admittance

**Tolerances:**

$\epsilon_d$	Substrate dielectric constant
$\sigma$	Standard deviation

**Appendix 1:**

A	Relative amplitude (dB) ) of two beams in far field )
$\theta$	Relative position (deg) ) method for evaluation of $\alpha$ and $\beta$
$\alpha$	Attenuation constant
$\beta$	Phase constant
$K_o$	Phase constant of stripline

10. TABLES

Table 5.1 Line Impedance Errors due to Substrate Dimensional Errors

Error type	Error in linear dimension	% Change in impedance			
		Microstrip		Stripline	
		70Ω	150Ω	70Ω	150Ω
Etch accuracy	0.006 mm	0.12	0.18	0.21	0.40
Stress Relief					
a) After etching one face	0.03%	0.02	0.01	0.02	0.01
b) After aging 1 hr @ 75°C	0.62%	0.41	0.25	0.47	0.33

Table 6.1

Summary of Achieved Flat Profile Antenna Performance

Array Type	Operation	Feed Type <sup>1</sup>		Broadside <sup>2</sup> Beam?	Side <sup>3</sup> lobe Level dB	Band Width %	Gain <sup>4</sup> dB	Losses, dB		Input VSIR	Polarisation	Frequency	Notes	Ref No	Page No
		Elements	Rows					Lines	Loads						
1. Microstrip strip radiators	Resonant	← Corporate	→	Yes	-11	1	21	0.5	-	2:1	LP	X-band		26	5
2. Dipoles	"	"	"	Yes	-12.5	5	28	3	-	1.3:1	LP	X-band		50	10
3. Ground plane slots	"	"	"	Yes	-22	NQ	17	<0.5	-	NQ	LP	X-band	Losses estimated by authors	60	11
4. Stripline slots	"	"	"	Yes	-25	6	21	2	-	2.5:1	LP	X-band		75	15
5. Microstrip narrow line resonators	"	Series	Series	Yes	-19	<2	NQ	NQ		1.5:1	LP	L to Q-band	Bandwidth dependent on beamwidth	20	2
6. Microstrip comb line	"	"	"	Yes	-20	<1	25	1	-	1.2:1	LP	X-band (10 GHz)		16	6
7. Dipoles, Franklin & collinear types	"	"	"	Yes	-11	<1	21	NQ		NQ	LP	S-band (2.8GHz)		59	11
8. Waveguide slot	"	"	"	Yes	NQ	1/2	NQ	NQ		1.4:1	L or CP	NQ	Polarisation and losses dependent on slot type used	85	17
9. Microstrip broad line resonators	Travelling wave	Series	Corporate	No	-10	1 1/2	17	<4		2:1	LP	X-band	Loss estimated by author	25	4
10. Microstrip serpent line	"	"	"	No	-20	15	15	<1	NQ	1.4:1	LP	X-band	Figures are for linear array only. Line losses are estimated by authors	39	7
11. Microstrip chain antenna	"	"	"	No	-10	16	<22	<2	0.1	1.1:1	LP	1.8 GHz	Line losses estimated by authors	38	7
12. Stripline periodically modulated antenna	"	"	"	No	-15	5	27	0.6	0.7	1.4:1	LP	X-band	Gain estimated by authors	78	15
13. Microstrip comb line	"	"	"	Yes	-18	2 1/2	25	1.6	1.4	1.1:1	LP	J-band (17 GHz)	Gain and losses predicted only	15	6
14. Sandwich wire antenna	"	Series	Series	Yes (elements individually matched)	-25	40	31	0.1	0.2	NQ	LP	X-band	Gain estimated by authors	47	7
15. Stripline slot	"	"	"	No	-25	NQ	26.5	0.75	NQ	1.2:1	LP	X-band (13.3GHz)		71	14
16. Waveguide slot	"	"	"	No	-28	10	23	← 2.2 →		NQ	L or CP	X-band	Lower losses could be obtained by using other radiating elements	105	20



Table 6.1 (continued)

Notes

1. The feed type is described as follows:

Elements      Each element in a row is fed either corporately or in series.

Rows            The input to each row is fed either corporately or in series.

2. A broadside beam can usually be obtained over the whole frequency band of a resonant antenna. In a travelling wave end fed type (which includes all the travelling wave types shown) the beam moves with frequency and in only some types can the beam move through a broadside position: these are marked 'Yes'.
3. The sidelobe level depends on the aperture distribution and required efficiency which are not listed. The figures above -13 dB are for apertures with a uniform distribution. The others indicate the sidelobe levels that have been obtained with each type.
4. The losses and bandwidth are dependent on the antenna gain. Usually the losses increase and bandwidth decreases with increasing gain in a resonant type whilst the bandwidth is not affected in a travelling wave type. The gain is quoted to allow useful comparison to be made.
5. NQ - Not quoted in reference  
LP - Linear polarisation  
CP - Circular polarisation.

Table 6.2

Comparison of Flat Profile Antenna Classes

	Advantages	Disadvantages
Microstrip Antennas	<ol style="list-style-type: none"><li>1. Thin profile</li><li>2. Light weight</li><li>3. Simple manufacture</li><li>4. Can be made conformal</li></ol>	<ol style="list-style-type: none"><li>1. Spurious radiation from feeds, junctions etc.</li><li>2. Surface waves</li><li>3. Operation not yet well understood</li></ol>
Cavity Backed Printed Antennas	<ol style="list-style-type: none"><li>1. Low line loss</li><li>2. Operation well understood (except sandwich wire antenna)</li></ol>	<ol style="list-style-type: none"><li>1. Thick profile (especially at low frequencies)</li><li>2. Narrow bandwidth (except sandwich wire antenna)</li><li>3. Difficult to make conformal</li></ol>
Stripline	<ol style="list-style-type: none"><li>1. Thin profile</li><li>2. Light weight</li><li>3. Shielded feed lines</li><li>4. Can be made conformal</li></ol>	<ol style="list-style-type: none"><li>1. Complex manufacture</li><li>2. Narrow bandwidth</li><li>3. Coupling inside structure</li></ol>
Waveguide	<ol style="list-style-type: none"><li>1. Low line loss</li><li>2. Operation understood</li></ol>	<ol style="list-style-type: none"><li>1. Thick profile (especially at low frequencies)</li><li>2. Complex manufacture</li><li>3. Difficult to make conformal</li></ol>

11 ILLUSTRATIONS

FIG 1. 1. MICROSTRIP TRANSMISSION LINE

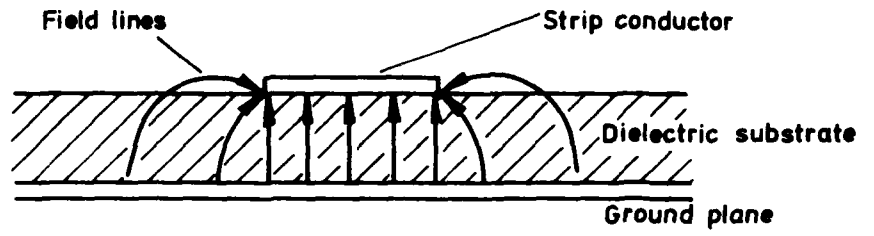


FIG. 1. 2. MICROSTRIP GEOMETRY

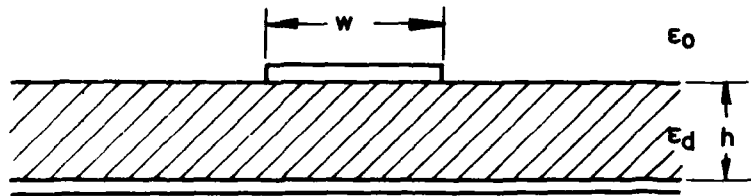
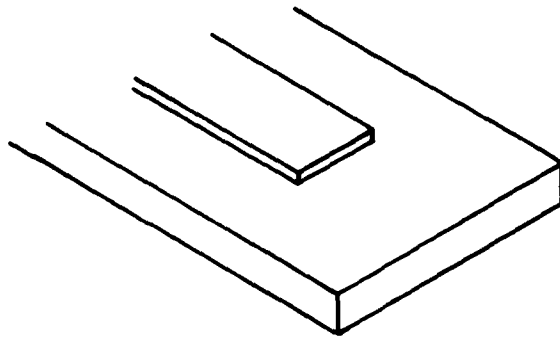
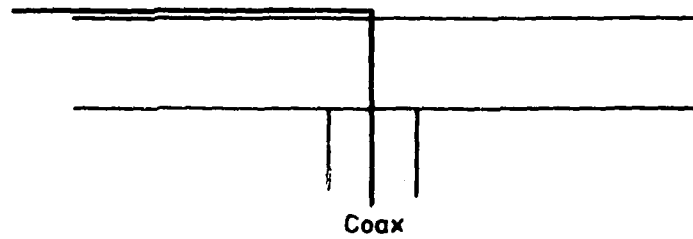


FIG. 1.3. MICROSTRIP DISCONTINUITES

a) Open Circuit Line



b) Matched Coaxial Transition



c) Right Angle Corner

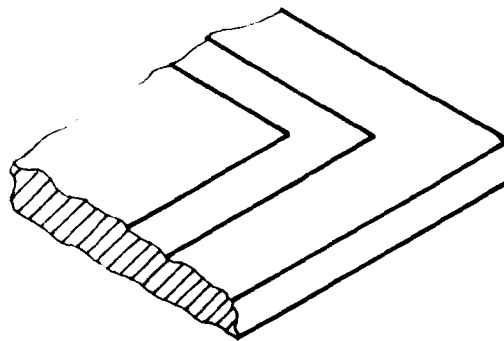


FIG. 1.4. NARROW LINE RESONANT RADIATOR

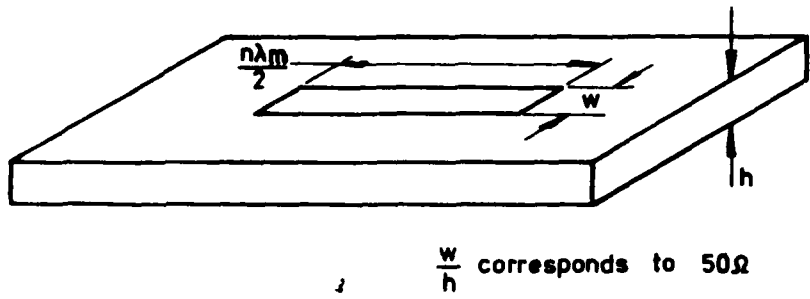


FIG. 1.5. LINEAR ARRAY OF RESONANT RADIATORS

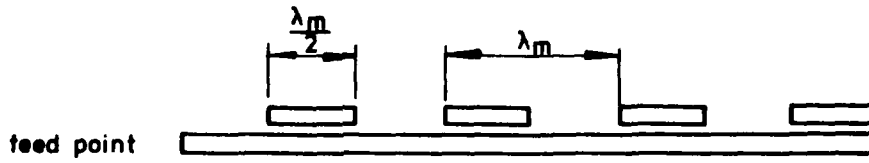


FIG. 1.6. RESONANT RADIATOR FED DIRECTLY BY LINE

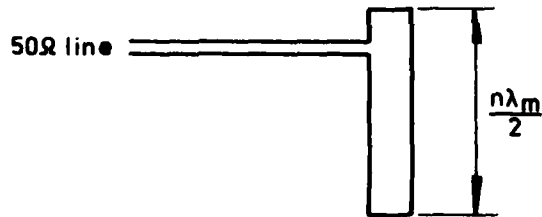


FIG. 1.7. CIRCULARLY POLARISED NARROW LINE RESONANT RADIATOR

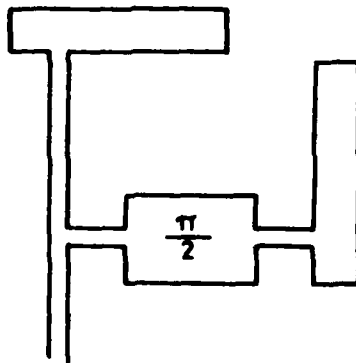


FIG. 1.8. BROAD LINE RESONANT RADIATOR

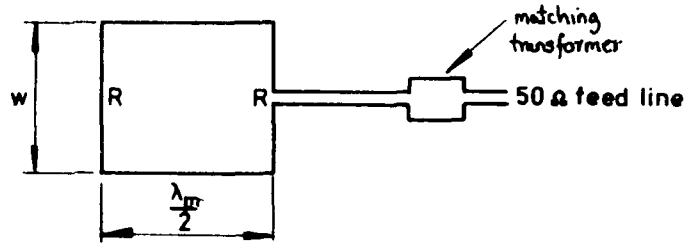


FIG. 1.9. ARRAY OF RESONANT RADIATORS

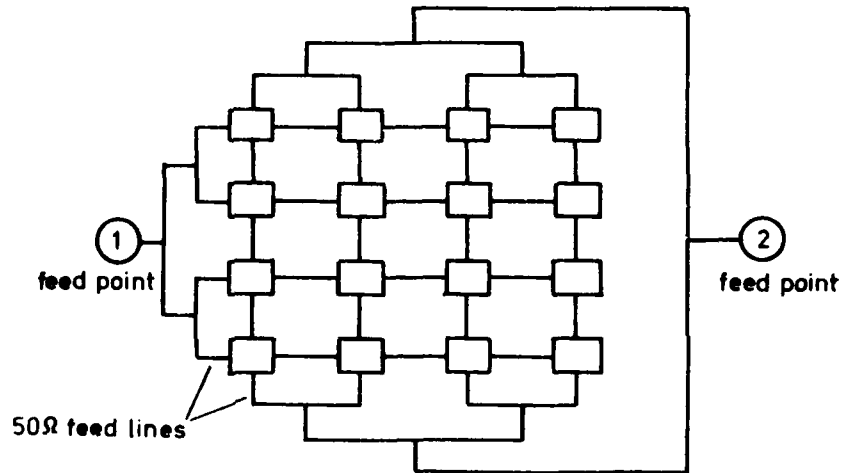


FIG. 1.10. CIRCULARLY POLARISED BROAD RESONANT RADIATOR

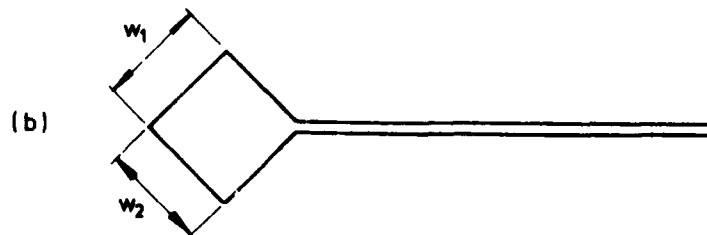
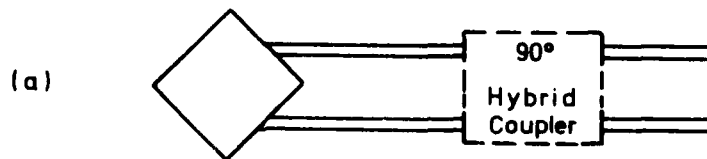


FIG. 1. 11. CIRCULARLY POLARISED DUAL FREQUENCY RESONANT RADIATOR

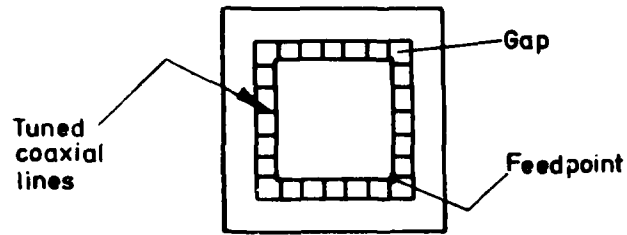


FIG. 1. 12. STRIP RADIATOR (BYRON)

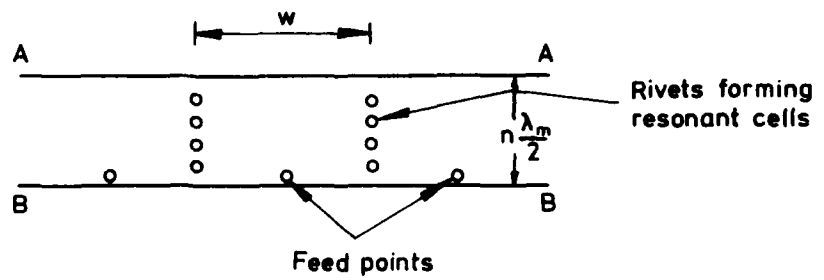


FIG. 1. 13. STRIP RADIATOR (MUNSON)

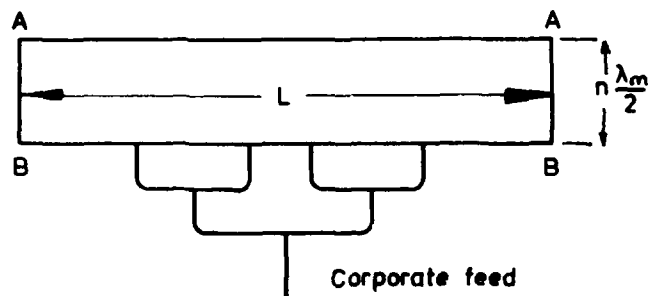


FIG. 1. 14. CIRCULAR RESONANT RADIATOR

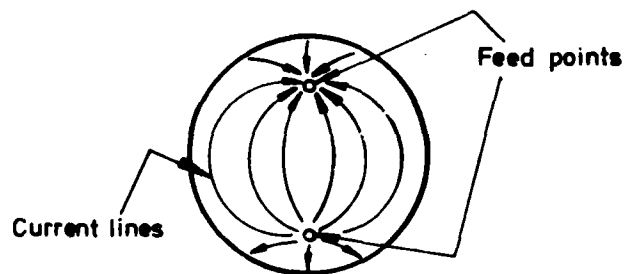


FIG. 1.15. CIRCULARLY POLARISED CIRCULAR RESONANT RADIATOR

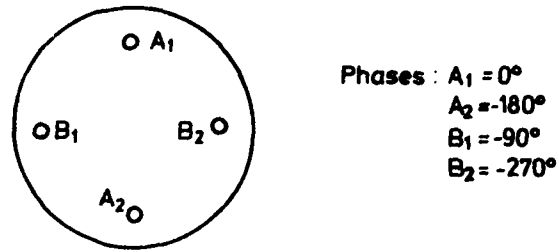


FIG. 1.16. CIRCULARLY POLARISED RESONANT RADIATOR (JAMES & WILSON)

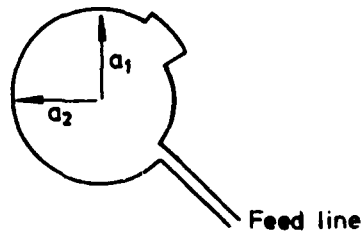
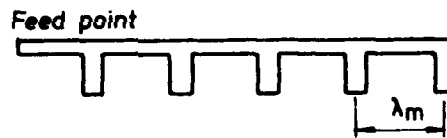
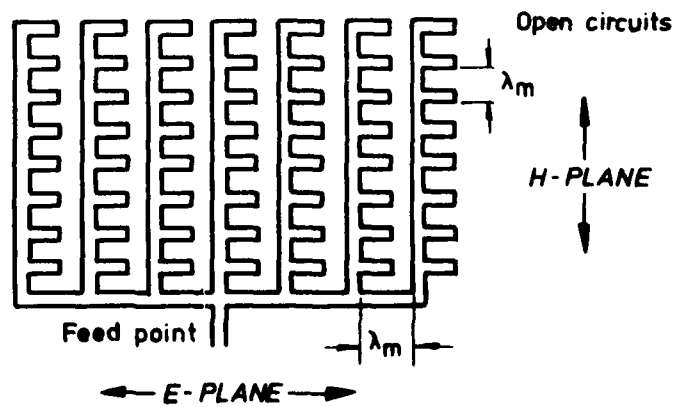


FIG. 1.17. COMB LINE ARRAYS

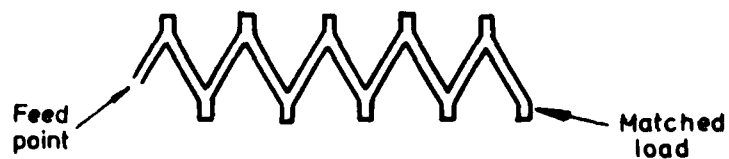
a) Linear



b) Two Dimensional

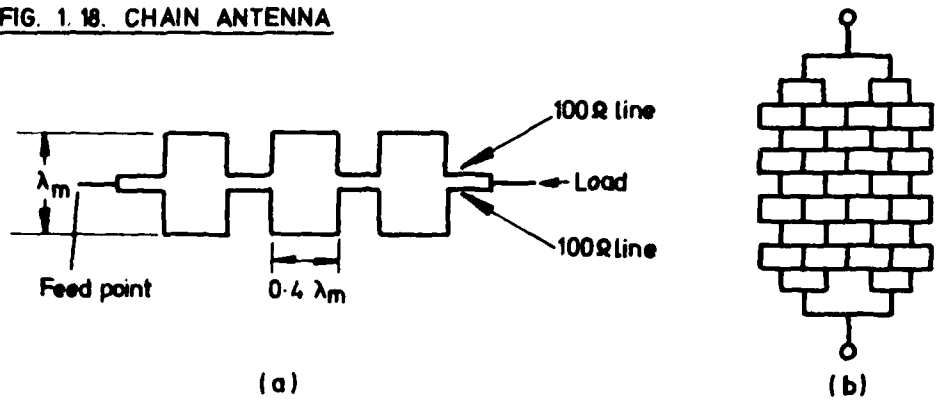


c) Zig-Zag

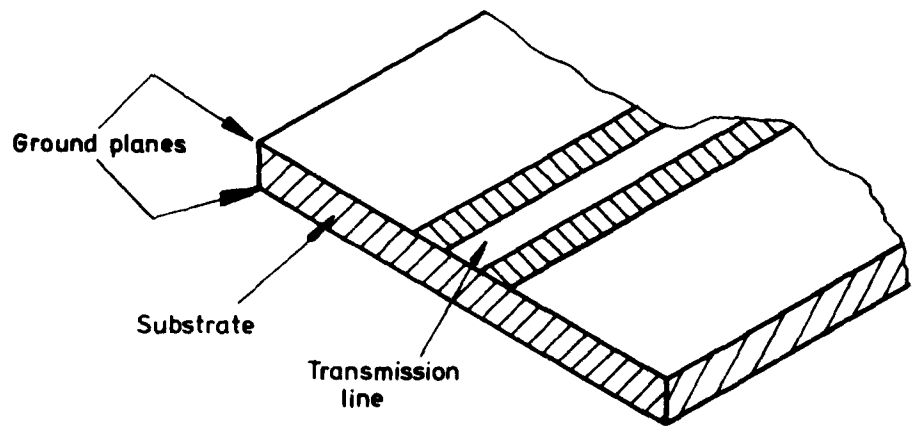




**FIG. 1.18. CHAIN ANTENNA**



**FIG. 1.19.a) COPLANAR STRIPLINE GEOMETRY**



**FIG. 1.19.b) COPLANAR STRIPLINE BROAD LINE RESONANT RADIATOR**

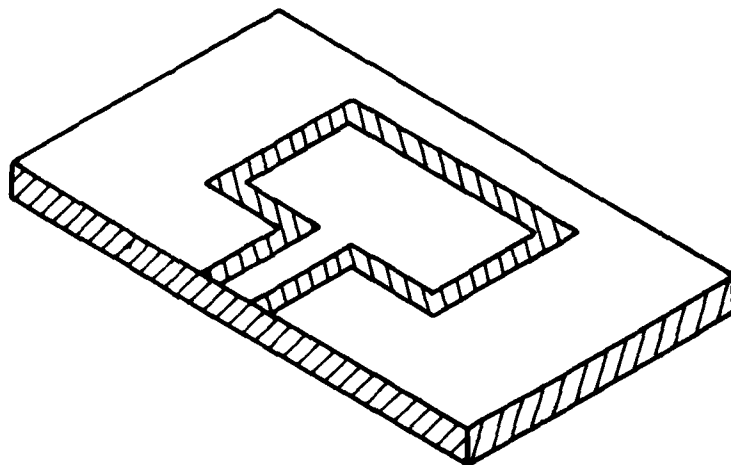


FIG. 2.1. THE SANDWICH WIRE ANTENNA : BASIC CONFIGURATION

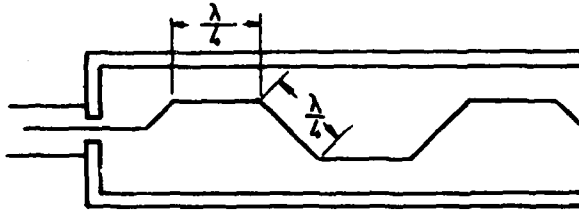
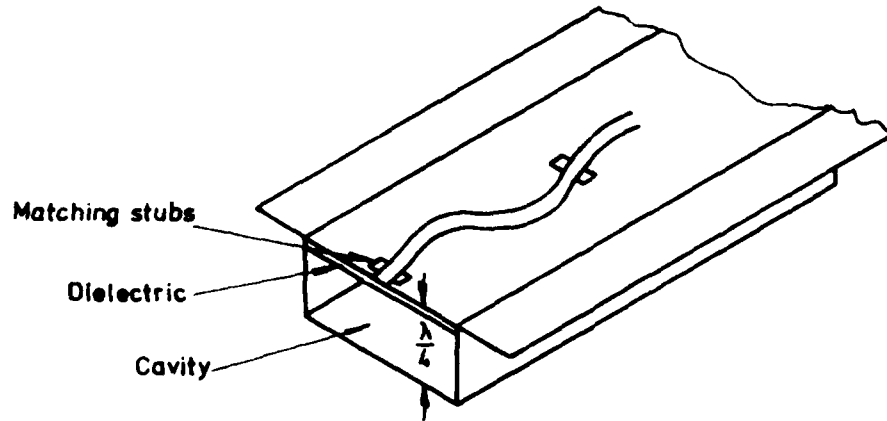
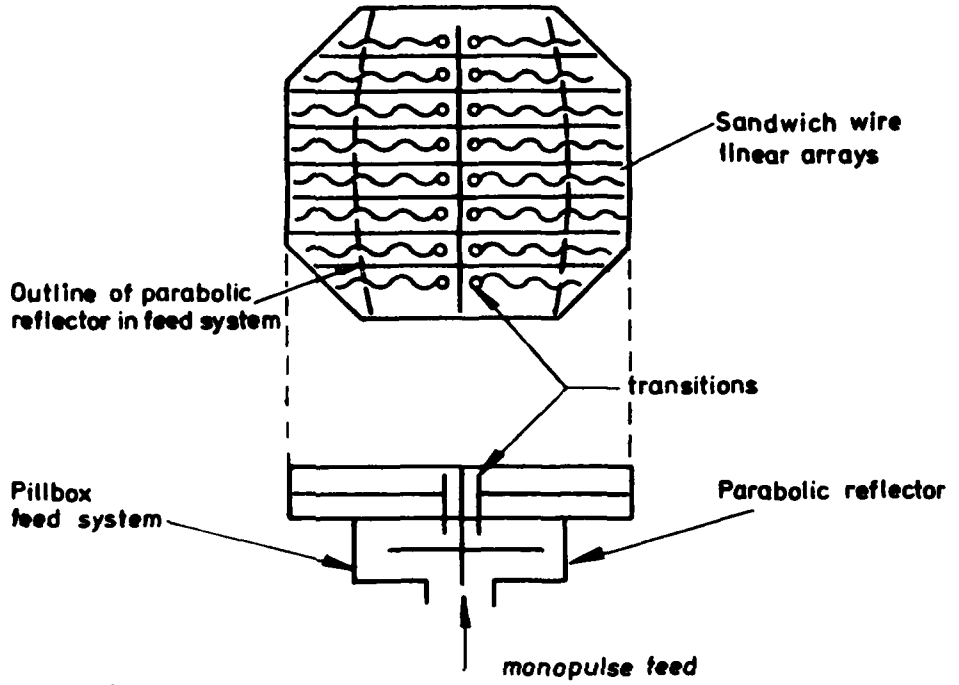


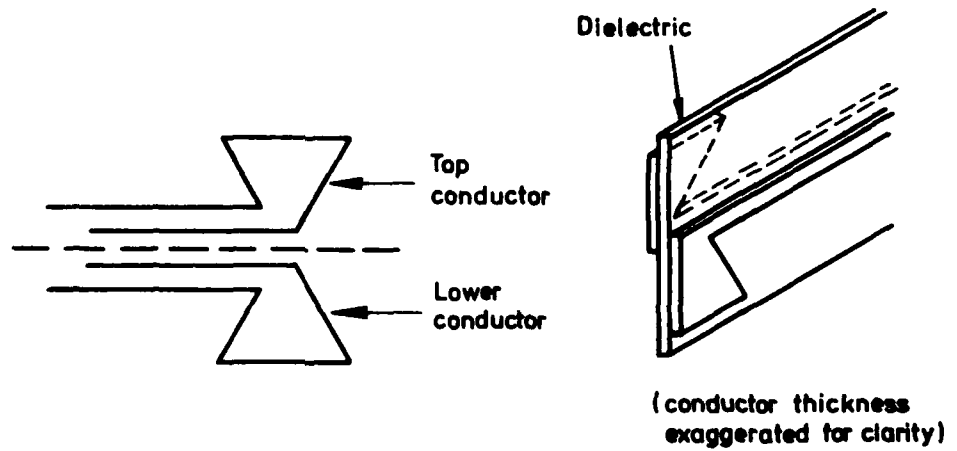
FIG. 2.2. THE SANDWICH WIRE ANTENNA : PRACTICAL DESIGN.



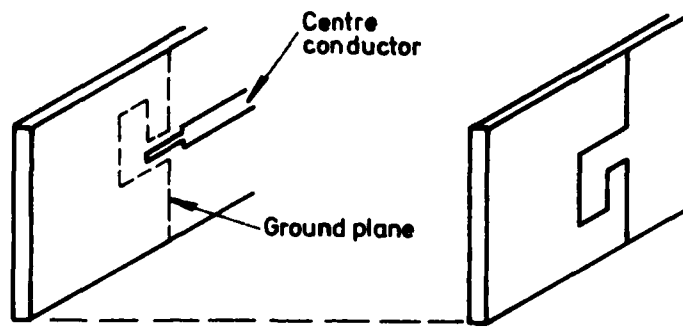
**FIG. 2.3. MONOPULSE ARRAY OF SANDWICH WIRE ANTENNAS**



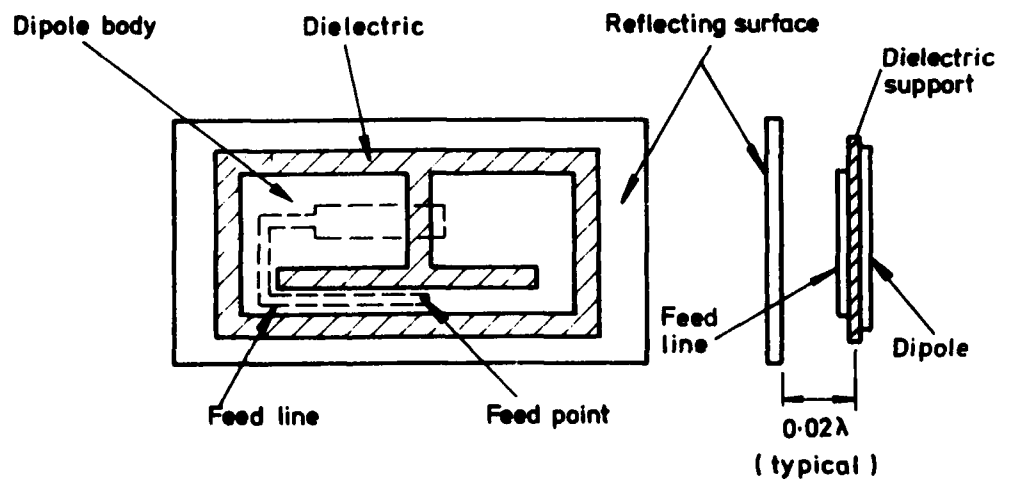
**FIG. 2.4. PRINTED DIPOLE**



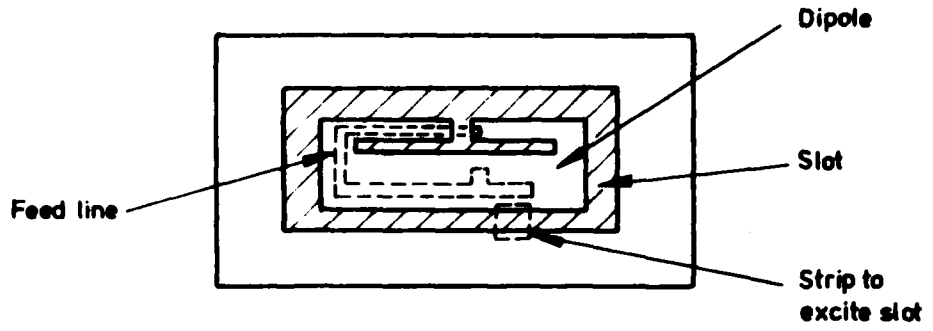
**FIG. 2.5. STRIPLINE FED PRINTED DIPOLE**



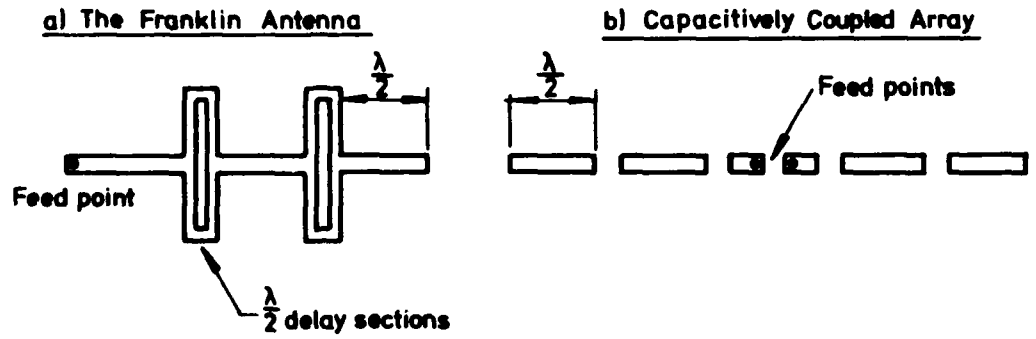
**FIG. 2.6. BROADBAND PRINTED DIPOLE**



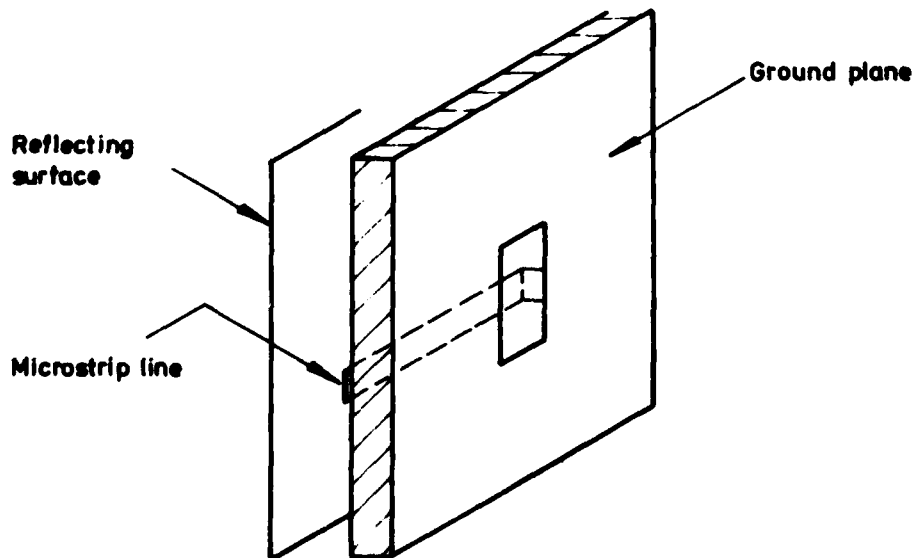
**FIG. 2.7. FLAT SLOT AND DIPOLE CONFIGURATION**



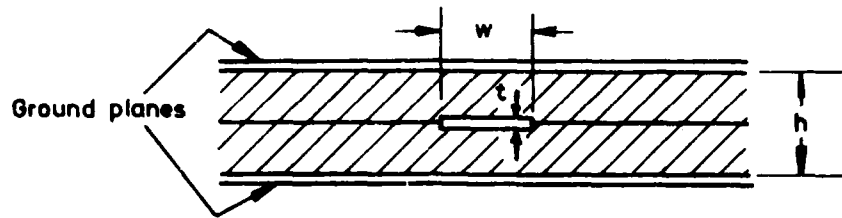
**FIG. 2.8. COLINEAR DIPOLE ARRAYS**



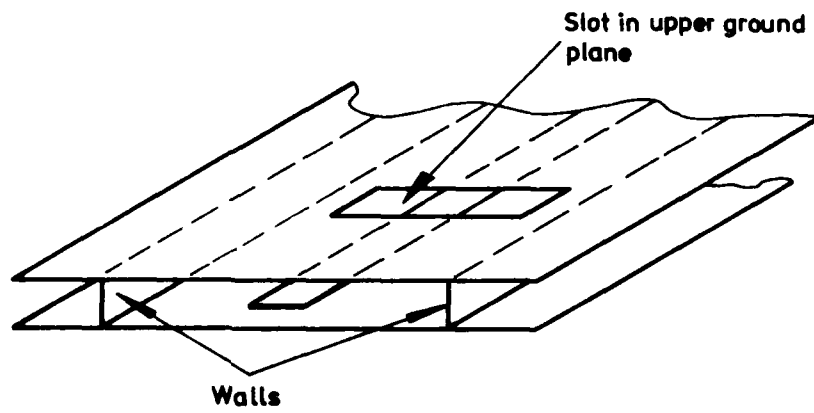
**FIG. 2.9. THE GROUND PLANE SLOT RADIATOR**



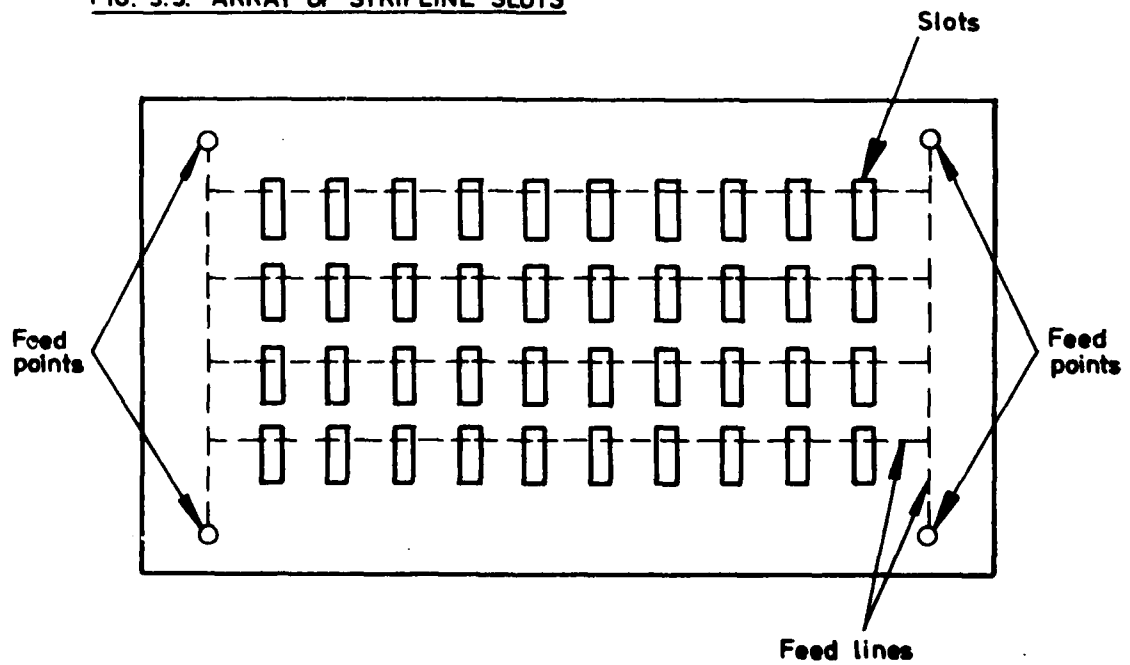
**FIG. 3.1. STRIPLINE TRANSMISSION LINE**



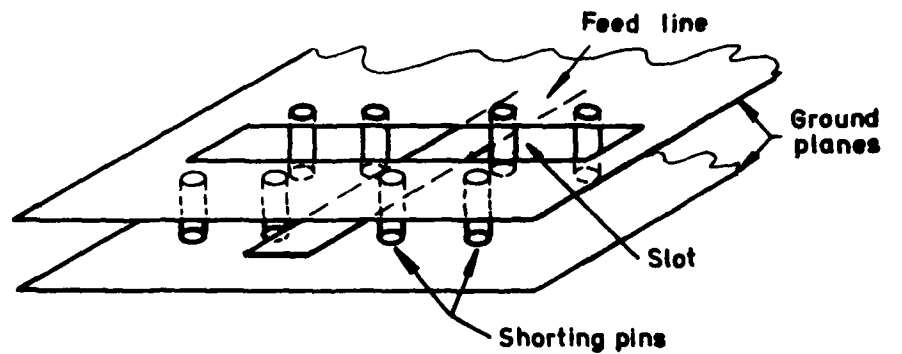
**FIG. 3.2. STRIPLINE SLOT RADIATOR**



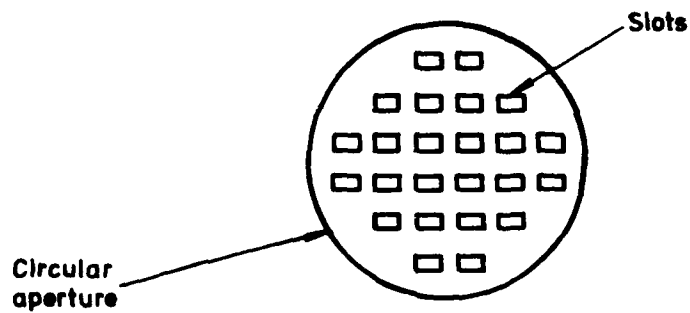
**FIG. 3.3. ARRAY OF STRIPLINE SLOTS**



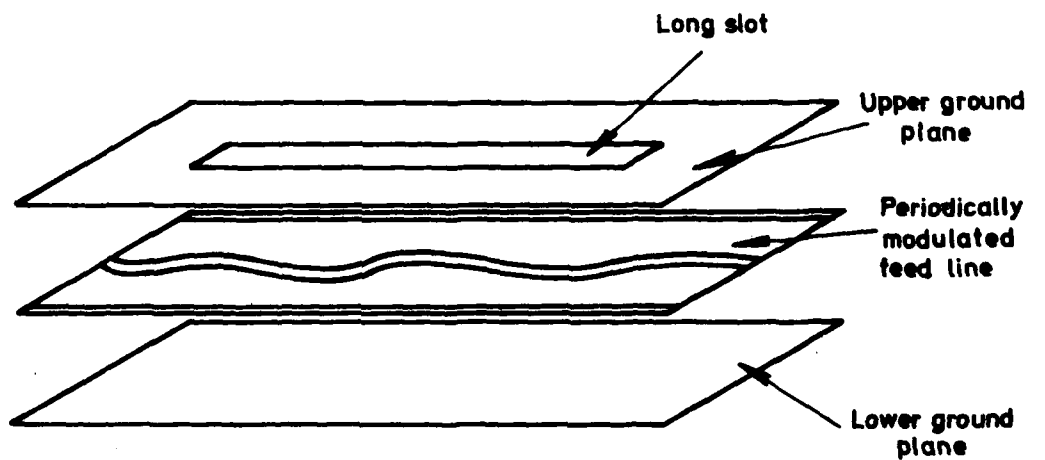
**FIG. 3.4. PRACTICAL SLOT DESIGN**



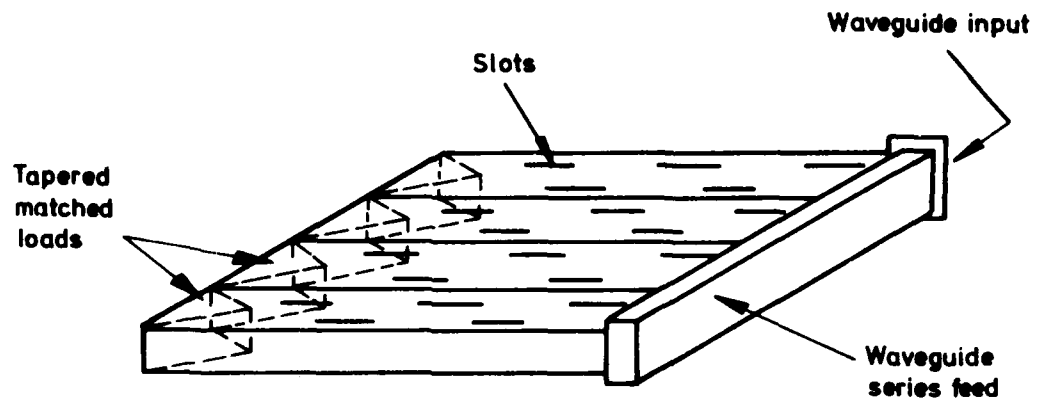
**FIG. 3.5. 32 ELEMENT SLOT ARRAY**



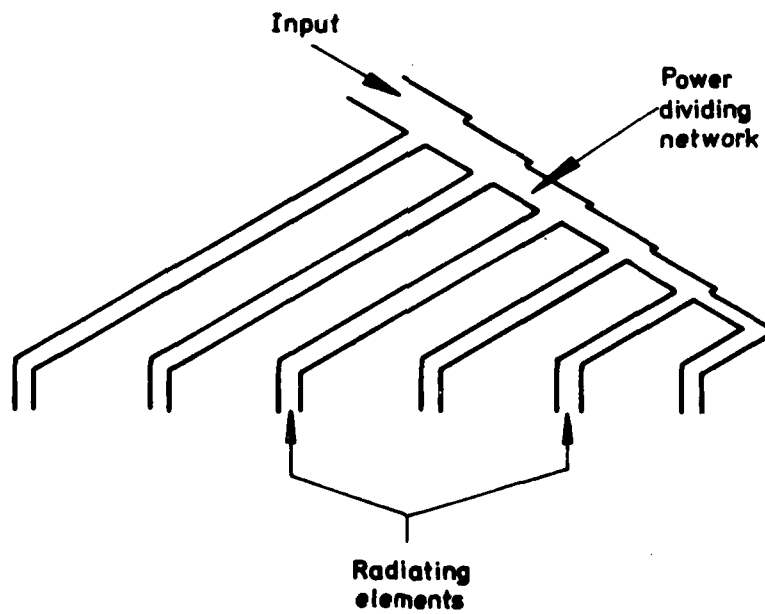
**FIG. 3.6. PERIODICALLY MODULATED RADIATOR**



**FIG. 4.1. TYPICAL WAVEGUIDE FLAT PROFILE ARRAY ANTENNA**



**FIG. 4.2. SQUINTLESS FEED SYSTEM**

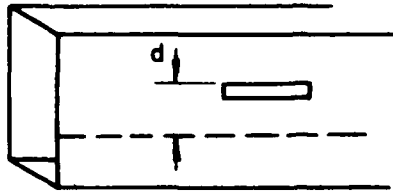




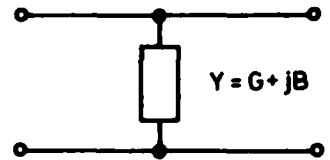
**FIG. 4.3. BASIC SLOT TYPES**

**a) Longitudinal Slot in Broad Face, Shunt Element**

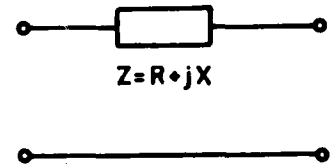
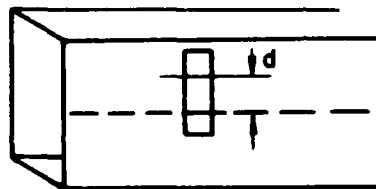
Geometry



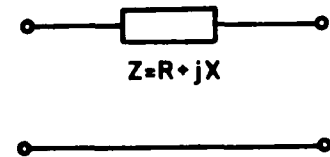
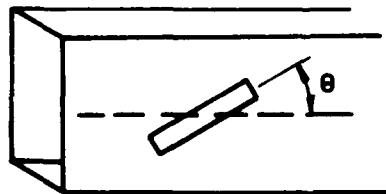
Equivalent Circuit



**b) Transverse Slot in Broad Face, Series Element**



**c) Centred Inclined Slot in Broad Face, Series Element**



**d) Inclined Slot in Narrow Face, Shunt Element**

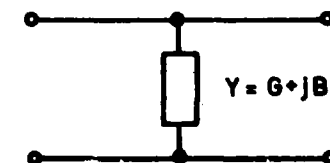
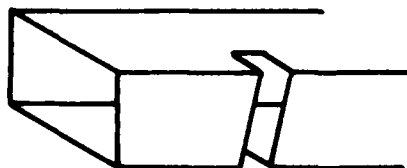


FIG. 4.4. DUMBELL AND 'H' SLOT

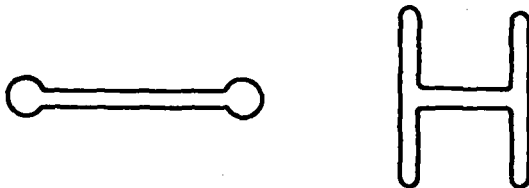


FIG. 4.5. 'H' SLOT IN NARROW WALL OF WAVEGUIDE

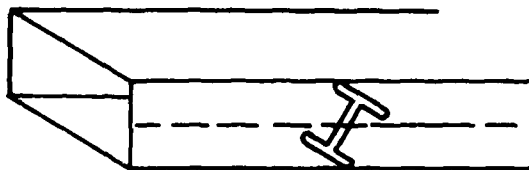


FIG. 4.6. 'I' SLOT

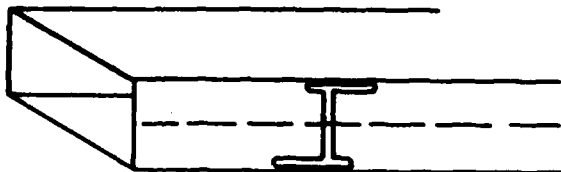


FIG. 4.7. PROBE AND IRIS FED SLOTS

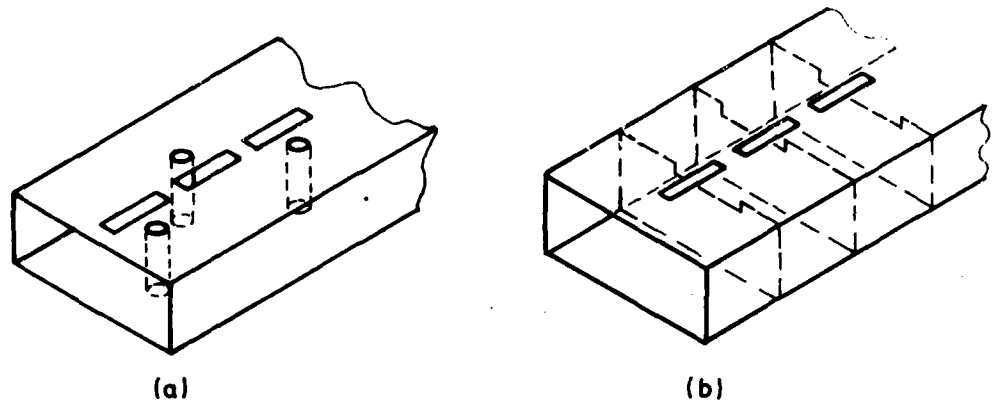


FIG. 4.8. SLOT WITH PARASITIC WIRES

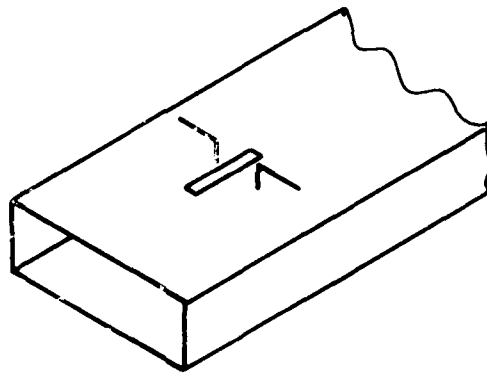
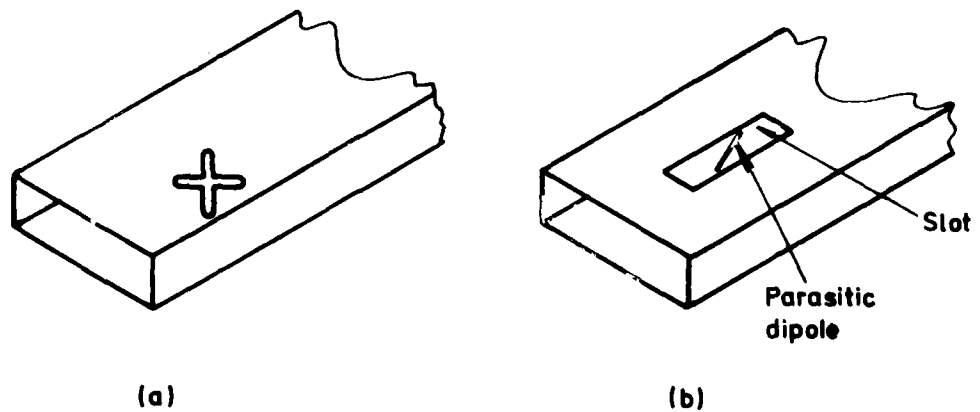
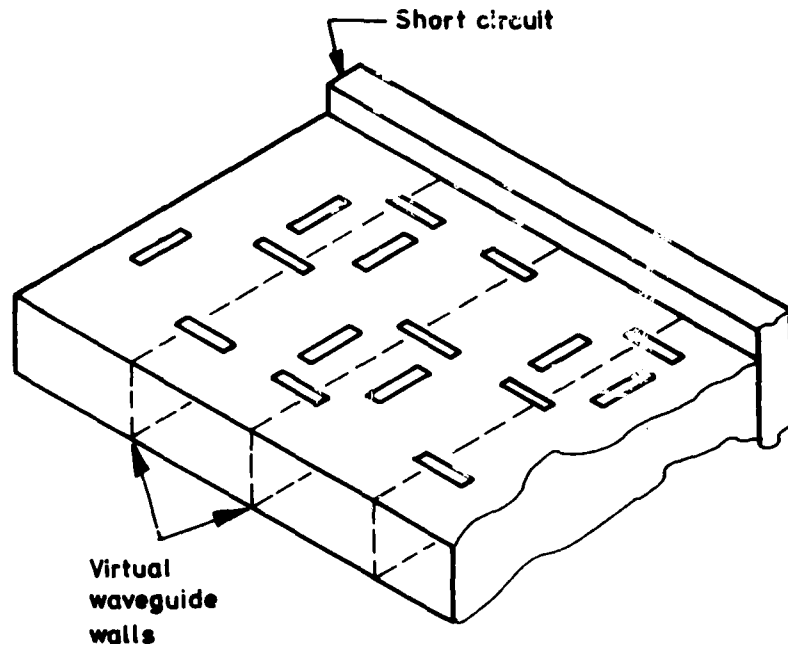


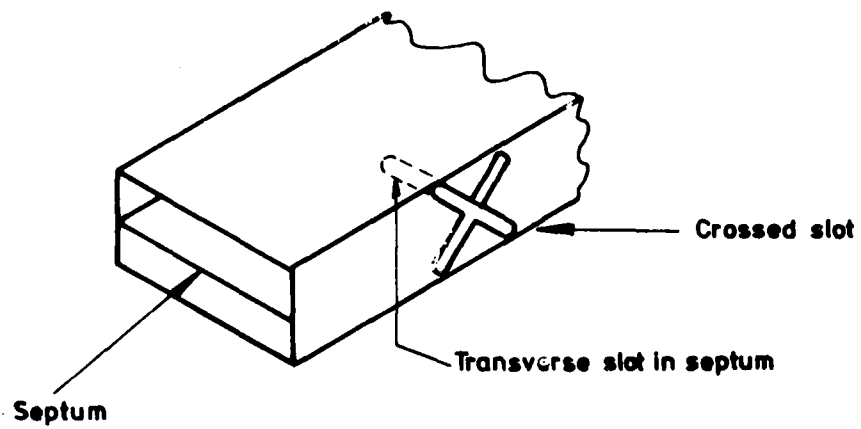
FIG. 4.9. CIRCULARLY POLARISED SLOT RADIATORS



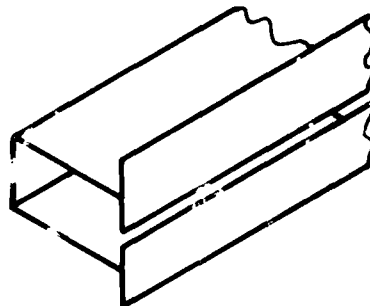
**FIG. 4.10. SECTION OF CIRCULARLY POLARISED PLANAR ARRAY**



**FIG. 4.11. SLOT FOR ARBITRARY POLARISATION**



**FIG. 4.12. LEAKY WAVE RADIATOR**



## 12. APPENDIX

### Measurement of Attenuation and Phase Constants of Travelling Wave

#### Antennas

The travelling wave guided by a periodic structure is characterised by a complex propagation coefficient  $\gamma = \alpha + j \beta$ , composed of an attenuation constant  $\alpha$  and phase constant,  $\beta$ .

Laursen (78) has described three methods of determining  $\alpha$  and  $\beta$  in order to design a periodically modulated stripline antenna. These methods are:

- 1) The far-field method - Jacobsen, (120)
- 2) The near-field method - Jacobsen, (120)
- 3) The insertion loss method - Montgomery, (121).

In the far field method the line is terminated by a short circuit, producing an incident and reflected wave on the structure. Each wave has a main beam associated with it, the relative amplitude,  $A$ , and position,  $\theta$ , of which are related to  $\alpha$  and  $\beta$  by the following expressions:

$$A = 20 \log. \exp (-\alpha L)$$

$$\beta = K_0 \sin \frac{\theta}{2}$$

where  $L$  is the structure length and  $K_0$  is the phase constant of the TEM mode on the structure. This method can be improved by using a movable short circuit and examining the sum and difference patterns obtained.

If the attenuation constant is so high that the sidelobes of the incident beam obscure the main beam due to the reflected wave, then the attenuation constant can be found from a plot of the near field decay along the line. This method is more inaccurate than the far field method and considerably more tedious.

The insertion loss method will only give the attenuation constant and must therefore be used in conjunction with the far field method.

REPORT DOCUMENTATION PAGE

(Notes on completion overleaf)

UNCLASSIFIED

Overall security classification of sheet .....

(As far as possible this sheet should contain only unclassified information. If it is necessary to enter classified information, the box concerned must be marked to indicate the classification eg (R),(C) or (S)).

1. DRIC Reference (if known) BR56300	2. Originator's Reference RT 103	3. Agency Reference D/DRLS/5/33/7	4. Report Security Classification UNCLASSIFIED
5. Originator's Code (if known)	6. Originator (Corporate Author) Name and Location Royal Military College of Science Shrivenham Swindon Wilts SN6 8LA		
5a. Sponsoring Agency's Code (if known)	6a. Sponsoring Agency (Contract Authority) Name and Location Royal Signals and Radar Establishment, St Andrews Road, Gt Malvern, Worcs WR14 3PS Procurement Executive, Ministry of Defence, DRLS, The Adelphi, John Adam Street, London WC2N6BB		
7. Title Survey of Flat Profile Microwave Antennas			
7a. Title in Foreign Language (in the case of translations) -			
7b. Presented at (for conference papers). Title, place and date of conference -			
8. Author 1. Surname, initials HALL P S	9a Author 2 JAMES J R	9b Authors 3, 4...	10. Date pp ref 11.1976 62 121
11 Contract Number AT/2160/033RL	12. Period	13. Project Improved printed microwave microstrip antenna	14. Other References
15. Distribution statement Unlimited			
Descriptors (or keywords) Antennas, Microwave, Flat, Survey			
Abstract The need for compact low profile antenna elements and arrays has in the past decade inspired many ingenious techniques embracing both conventional waveguides and the more recent printed assemblies. While printed techniques appear to offer more attractive features it is instructive to note all the various configurations that have been considered because some of the electrical constraints are similar. This report is an outline survey of such radiators and although it is not the intention to discuss any particular antenna in depth, sufficient details and references are given, where available, to indicate the performance obtained and the device potential.			