



Help

DCC800
DC Drives

**Crane drive basics
G567e Part 1**

eLearning

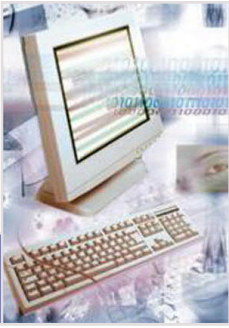

© Copyright. 11/8/2021 ABB. All rights reserved.
CraneDriveBasicsR0101. page 1



Welcome to the crane drive basic training module for the DCS800, ABB DC drives.

If you need help navigating this module, please click the Help button in the top right-hand corner. To view the presenter notes as text, please click the Notes button in the bottom right corner.

Objectives

This module is about:

- Types of crane systems
- DCS800 Crane drive functions
- DCS800 Crane drive ordering



This module is about:

- Types of crane systems
- DCS800 crane drive functions
- DCS800 crane drive ordering

Actual Crane Business for DC drives

- New crane systems are often equipped with a DC drive for the main hoist
- Revamping of old analog DC drives
- Combining Crane Systems together with AC drives (ACC800)



The ABB logo, consisting of the letters 'ABB' in a bold, red, sans-serif font.

The actual crane business for DC drives is as follows:

- New crane systems are often equipped with a DC drive for the main hoist. The Reason for this is the smaller amount of weight of a DC motor compared to an AC motor with the same power because the hoist motor is mounted directly on the crane.
- Revamping of old analog DC drives is also a business for DC drives. There is a large installed base of existing DC drive motors and drives from several manufacturers, which can be upgraded with new DCS800 converters.
- New crane systems are very often designed in a mixed structure. AC drives are used for the gantry and trolley motion due to the smaller amount of power needed. The high-power hoist drives are built with DC drives.

Names of crane parts

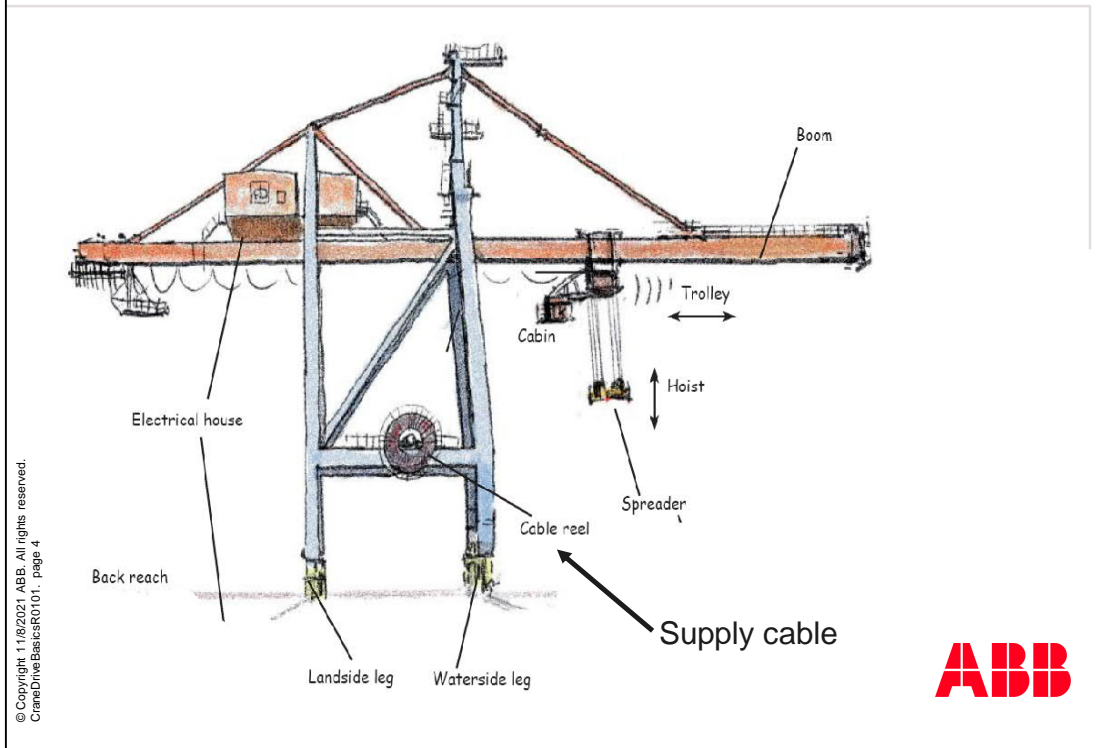

Before starting this module, the names of crane parts should be explained using the container crane as an example.

- On the upper side of the crane is the boom, which is a track for the trolley and the cabin.
- The trolley can move along the boom, which is controlled by the operator who is sitting in the cabin.
- The hoist is equipped with a spreader or hook hanging on a rope to move the load up and down.
- All the electrical equipment is placed in the electrical house, which is typically located on the top of the crane.
- Such a crane is supplied by high voltage cables and cable reels. The high voltage transformer sits on the crane.
- The complete crane stands on a gantry, which moves the entire crane along the quay.

Types of cranes

- Tower Crane
- Ship to Shore Container Crane (STS)
 - Single Trolley Crane
 - Double Trolley Crane
- Rail Mounted Gantry Crane (RMG)
- Rubber Tire Gantry Container Crane (RTG)
- Grab Ship Unloader (GSU)
- Shipyard Crane
- Electric Overhead Travelling Crane (EOT)

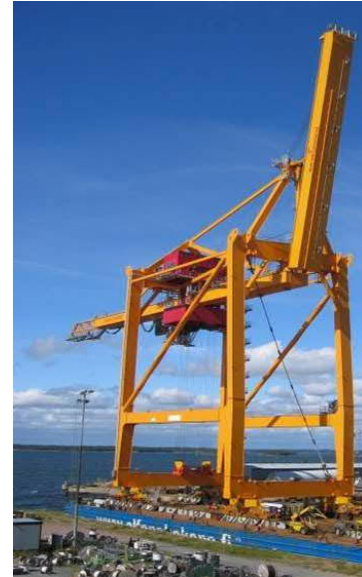
**ABB**

There are several different types of cranes. We will begin with the easiest type,

- the tower crane, which is often used for house building and transporting light loads.
- A ship to shore container crane is used in a harbor to unload ships. Types of this crane include single trolley cranes and double trolley cranes.
- A rail mounted gantry crane is a typical container crane in a railway terminal.
- Rubber tire gantry container cranes are built on tires and used to move the container from truck to stock.
- Grab ship unloaders are used for unloading boats with bulk cargo load like coal, sand or corn.
- A shipyard crane is used to build boats or oil rigs. This type of crane does not operate as fast but works with higher accuracy.
- Electric overhead travelling cranes are used for lifting and shifting material inside a building or inside a factory.

Tower Crane

- A tower crane is often transportable and will be built on site
- This type of crane is light therefore all crane components should be light
- Drives, motors and gearboxes are at the top of the tower
- Small cranes are typically driven by AC motors
- Small and simple control concept



ABB

A tower crane is often transportable and will be built on site. This type of crane is light therefore all crane components should be light. Drives, motors and gearboxes are placed at the top of the tower. Small cranes are typically driven by AC motors, which are not speed controlled because they only use a two speed "Dahlander" motor control. Bigger cranes can have DC motors and drives to control the hoist. The advantage of tower cranes is that they have a small and simple control concept.

Single Trolley Crane (Ship to Shore)

- Classic harbor crane
- The trolley transports container from ship to shore
- The hoist sometimes has a double motor configuration
- Shared motion between hoist – gantry or trolley – boom
- Smooth brake control reduces damage to goods
- High voltage supply cable
- Anti Sway Control

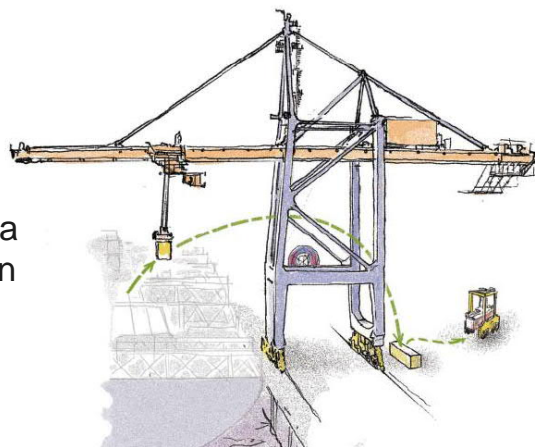
**ABB**

A single trolley crane is a typical ship to shore crane system. This is the classic harbor crane for container transport.

The main task of this crane system is to transport containers from ship to shore. Sometimes big cranes can have a double motor hoist configuration. Typical for such DC crane systems is shared motion between hoist and gantry, as well as between trolley and boom. Smooth brake control also reduces damaging goods, which is recommended for expensive goods. On the crane there is a high voltage supply cable to supply the crane with energy. Anti-sway control means a monitoring of the hanging container with a camera, which is mounted on the trolley. The amplitude of swaying influences the speed of the trolley. This functionality is only available with an external PLC to control the crane drive.

The speed for loading or unloading goods is always important for container cranes. A high unload speed for example reduces the waiting time of the ship.

Double Trolley Crane

- Two trolleys are mounted on the crane
- The first trolley is on the upper boom for large transport distances
- The second trolley on the lower boom is used for short distances
- Double capacity

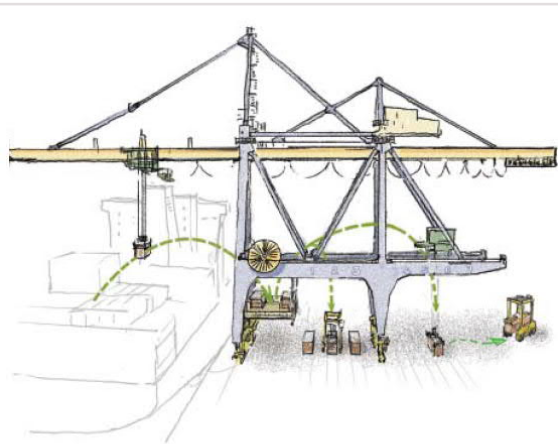

Double trolley crane

ABB

The advanced version of the previously explained container crane is the double trolley crane. This type is an uncommon crane type.

A double trolley crane has two functionalities. Two trolleys are mounted on the crane on different booms. The first trolley is on the upper boom for the STS function. The second trolley is on the lower boom, which is used to load trucks. The advantage of this double trolley configuration is the double capacity.

Rail Mounted Gantry Crane (RMG)

- The railway crane is used to transport containers in a railway terminal
- The crane moves on rails in one direction and the trolley in the other

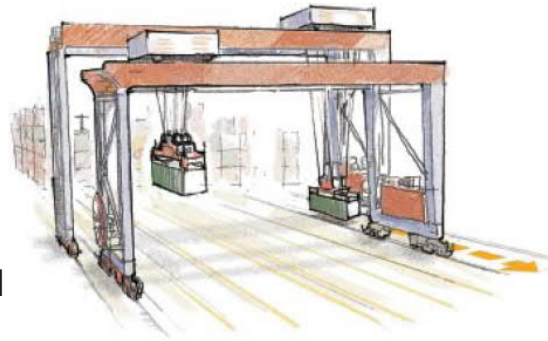

Auto RMG crane (Rail Mounted Gantry)

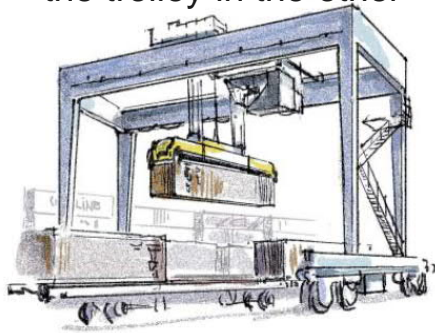

Railway crane

- Specialized yard container handling machines for 20 foot or 40 foot containers



A rail mounted gantry crane is an autocrane system, which moves on rails. It is used for example to transport containers in a goods station. The crane moves on rails in one direction and the gantry in the other.

These types are special yard container handling machines used for 20 foot or 40 foot containers.

Rubber Tire Gantry Crane (RTG)

- The RTG crane travels on tires
- The gantry is also equipped with steering
- This type of crane needs a level area for operation



RTG crane (Rubber Tyre Gantry)

- Powered by diesel engine

ABB

Rubber tire gantry cranes are equipped with tires to move the gantry freely through a container yard. The tires are used for steering and moving the gantry in all directions. This type of crane needs a flat area to operate. Rubber tire cranes are powered by a diesel engine, which is coupled with a generator to produce electrical power for the drives.

The advantage of this crane type is flexible operation without any cable connection.

Grab Ship Unloader Crane (GSU)

- The GSU crane is used to unload ships with bulk cargo
- The hoist is operated by two equal motors
 - Master-Follower-Mode
 - Speed-Control-Mode
- The hoist can have a high overload level
- The external PLC gives commands to open and close the grab



ABB

Grab ship unloader cranes are used to unload ships with bulk cargo. The hoist is operated by two equal motors. These two motors work either in master follower mode, which means both have the same speed, or work separate in speed control mode. In this configuration the hoist can have a high overload level during operation. The logic to control a four-rope grab is implemented in an external PLC, because the software program is relatively complex.

Grabber functionality

- Functionality of the grabber with four rope connection
- Motor 1 drives the grabber up and down
- Motor 2 is used to open or close the grabber
- If motor 1 and 2 are operating with the same speed the grabber remains the opening angle
- If motor 1 and 2 are operating with unequal speed the grabber opens or closes

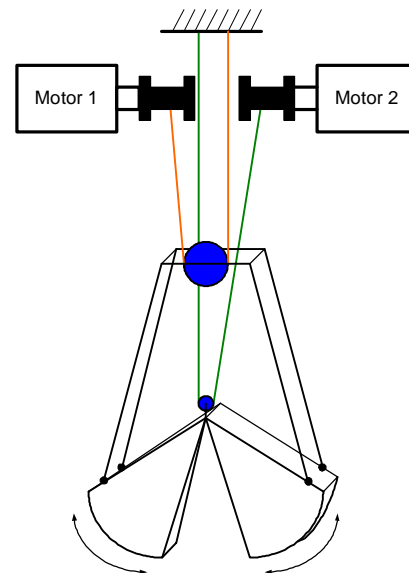

ABB

The main grabber functionality will be described on this slide. Grabbers typically have a four-rope connection. That means two motors are needed to control the grabber. Motor 1 drives the grabber up and down. The rope is connected to the frame of the holder. Motor 2 is used to open or close the grabber.

The main functionality is as follows:

If motor 1 and 2 are operating at the same speed, then the grabber remains at the same opening angle. In case that motor 1 and 2 are operating with different speeds, then the grabber opens or closes.

The logic to control the grabber is implemented in the crane drive PLC. The operator only controls the joystick.

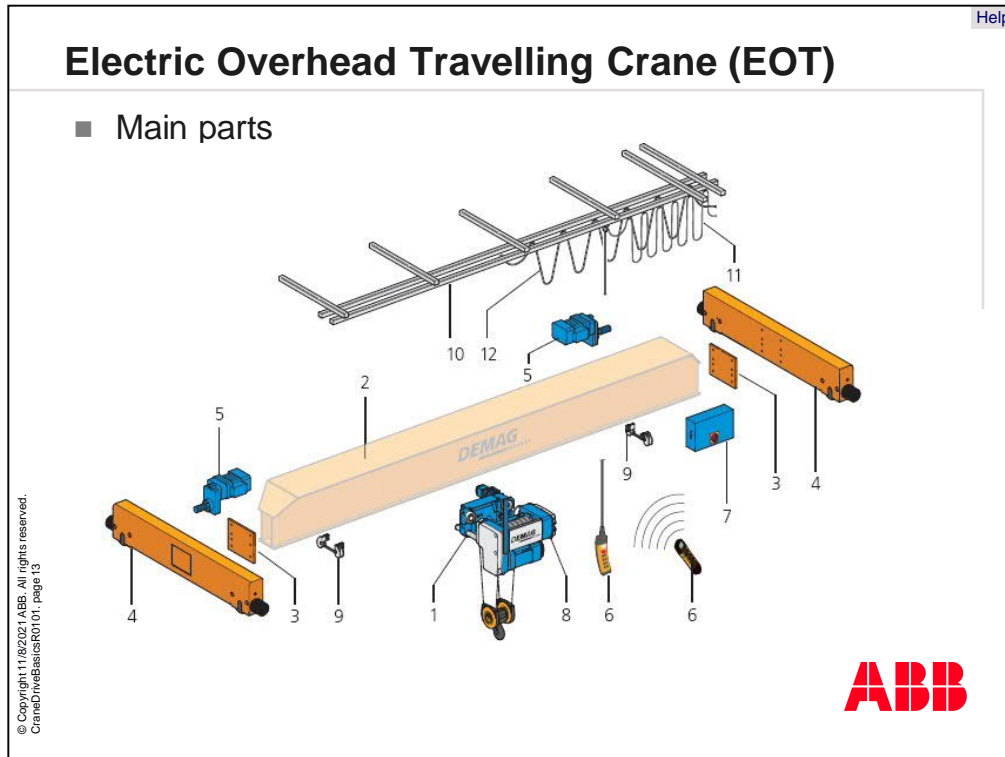

The Electric Overhead Travelling Crane is explained on this slide.

Here are the main parts:

1. Crab or travelling hoist with drive
2. Crane girder
3. Crane girder end plates
4. End carriage
5. Travel drive
6. Control pendant or radio remote control
7. Crane electrical equipment
8. Hoist electrical equipment
 - with lifting limit switch
 - with load detector
9. Clamp-fitted buffer
10. C-rail assembly
11. Power supply
12. Hoist power supply

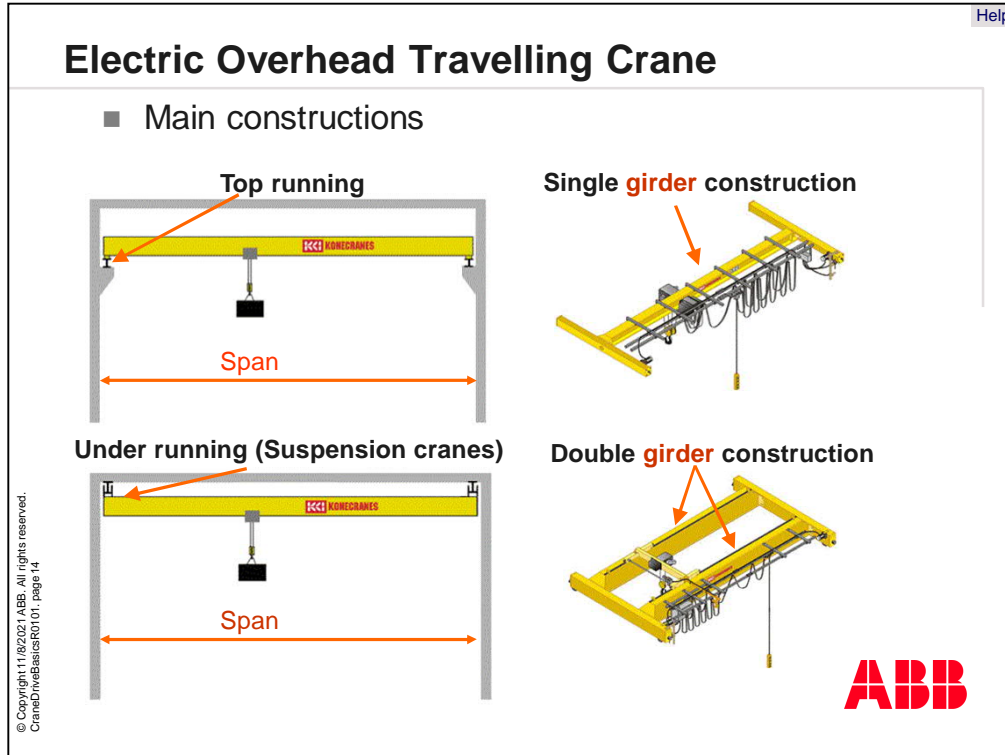

An **Electric Overhead Traveling Crane** or an **Overhead travelling crane**, also known as an **Overhead crane** or as a **Suspended crane** is a crane, which you usually see inside a factory or a warehouse.

It travels on rails high above the ground. It normally has three different movements, which are driven by electric motors.

- Hoist is the drive lifting and lowering.
- Bridge (or gantry) is the longitude movement
- Trolley is the traverse movement.

The design of the building structure determines if the best solution is the top running or under running design.

Top running is the most common form of crane design where the crane loads are transferred to the building columns or free-standing country structure.

Minimum headroom / maximum height of lift.

Under running construction is used when the lowest possible construction is required and the building design allows suspension from the roof structure. Overhead cranes with under running constructions are called Suspension Cranes.

Span:

Span is the center-to-center distance between runway rails. Typically, the distance is approximately 500mm less than the width of the building.

Girder:

According to the span and the maximum load handling capacity, the crane steel structure uses either a **single** or **double girder** crane construction.

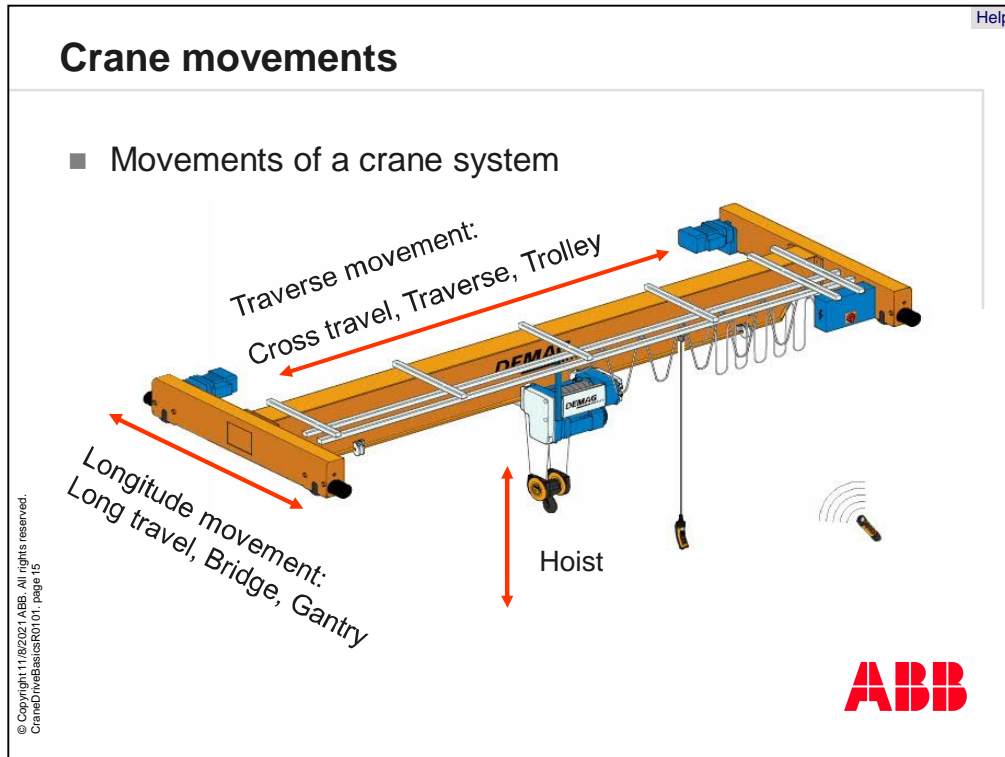

A crane can be moved in all directions. This will be done with a movement system in two directions.

There is the Traverse movement.

- This is a Cross travel of the trolley along the traverse.

Next is the Longitude movement.

- This is a Long travel of the bridge or gantry along the trackage.

The hoist can be moved up and down with the hoist motor.

Container Crane principal function

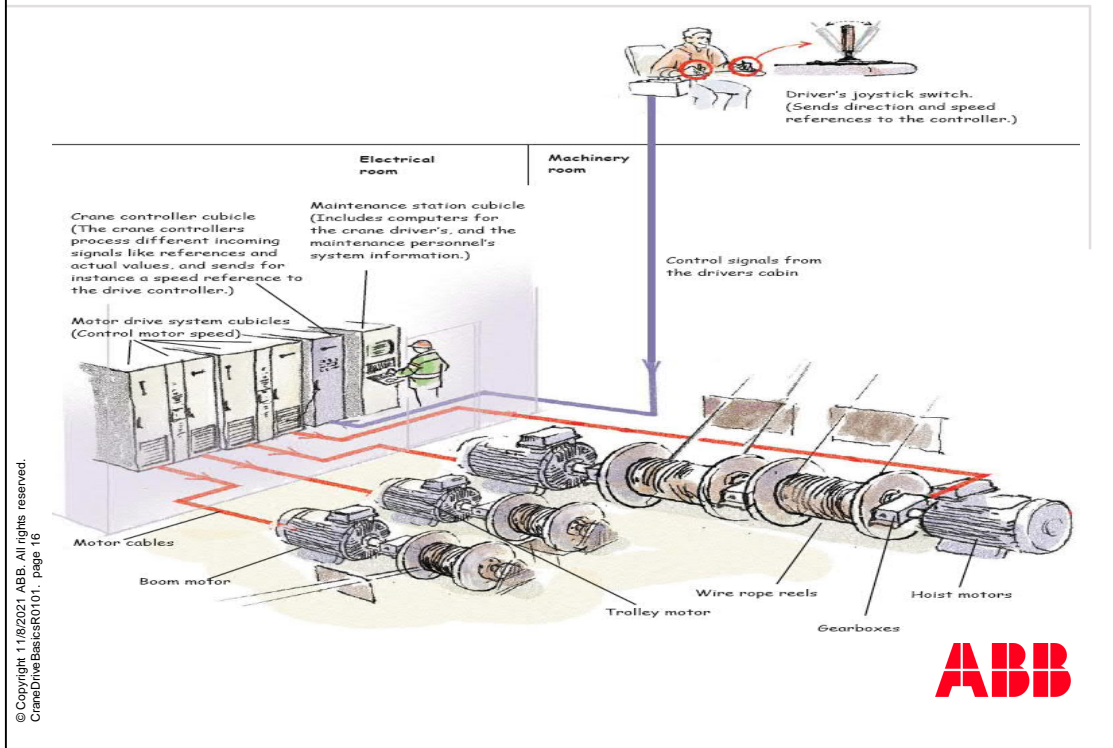

The principle function of a container crane will be explained on this slide. The driver's joystick switch in the cabin is connected to the electrical room and sends direction and speed references to the controller. This could be a PLC or the drive itself.

All drives and controllers are in the electrical room. The electrical room is located at the top of the crane. The motors and rope reels are placed in the machinery room. Depending on the crane type a boom motor, trolley motor and hoist motors are needed.

Crane arguments for DC drives

- Motors should be light-weight
- Low inertia for high acceleration and short cycle times
- Small size of 4-Quadrant drive and motor
- Upgrading of old analog DC drives



There are a lot of pros and cons regarding DC drive cranes.

- Light weight motors. This is important because they are mounted on the movable part.
- Low inertia of the crane drive – This is needed, because high dynamic is required.
- Small 4-quadrant drives and motors. – This is necessary, because the space in the electrical room is limited.
- Upgrading of old analog DC drives.

Depending on the requirements and costs, a DC drive crane system could be an alternative solution.

What is a DCS800 Crane Drive?

- DCS800 hardware with crane application software to be used both for Hoist and Travel motions
- Stand alone operation achieved by using only basic I/O in DCS800 (where required RDIO)
- Field bus communication via module-bus
→ AC70, AC80, AC410, AC450 and AC800M
- Field bus communication by option modules
→ e.g. RDNA, RCNA, RCAN, RPBA
- Master-Follower macro for two-way point-to-point communication with one follower or broadcast to multiple followers
- Torque proving, brake control and torque memory 

What is the DCS800 Crane Drive?

- The DCS800 hardware with crane drive program is to be used for both Hoist and Travel motions.
- Stand alone operation is achieved by using only basic I/O in DCS800. Sometimes a digital I/O extension module could be required!
- Control the crane with field bus communication by module-bus. Possible PLC systems are AC70, AC80, AC410, AC450 and AC800M.
- Control the crane with field bus communication by option modules. Possible field buses are Device Net, Control Net, Can bus and Profibus.
- There is also a master-follower macro for two-way point-to-point communication with one follower or broadcast to multiple followers.
- Also important for a crane drive is the brake logic, which includes torque proving and torque memory.

Help

DCS800 Standard Drive Functions

General Protections
Motor overspeed
Motor overcurrent

Controller
Field current controller
Armature current controller
Speed controller
Ramp function

Diagnostics
Fault logger
Data logger

**DCS800 converter
with standard firmware**



Parameter set-up
DriveWindow
DCS800 control panel

Parameter share
User 1 & User 2
Motor 1 & Motor 2

Start / Stop order
Release controllers
Control main contactor
Control I/O's

These functions are standard DCS800 functions,
which are used together with the crane drive!



© Copyright 11/8/2021 ABB. All rights reserved.
CraneDriveBasicsR0101, page 19

The DCS800 Standard Drive Functions are used for the crane software.

- General protections for the drive and motor are also used for a crane. For example, motor overspeed, motor overcurrent or acknowledge monitoring.
- Armature and field current control is needed for basic motor control. The speed controller is also used as long as the drive is in speed control mode. The ramp function is used to control the speed reference handling.
- Diagnostic functionalities like fault logger and datalogger are helpful to find drive faults quickly.
- Parameter set-up can be done via the DriveWindow software tool and the DCS800 control panel. DriveWindow also offers a recording feature to check actual signals of the drive.
- For some cranes two separate parameter sets are needed. Switching between user 1 and user 2 macros can be used for emergency operation in case of a PLC break-down. Switching between motor 1 and motor 2 macro is normally used for shared motion, e.g., one converter for trolley - boom.
- Start and stop order means for example the release of all controllers, the control of the main contactor and the control of inputs and outputs as well as brake control.

These functions are standard DCS800 functions, which are used together with the crane drive!

Help

DCC800 Crane Drive Functions

Logic Handling
 Start / Stop logic
 Limit Sw. Supervision
 Fast Stop function
 Mech. Brake control

**Crane software
on the Memory Card**



DCC800

Reference Handling
 I/O-handling
 Deadzone
 S-ramp
 Adjustable ramp shapes

Crane Protections
 Monitoring for:
 Torque, Speed,
 Fieldbus, Mech. brake,
 Converter overload,
 Torque proving

Additional functions
 Field bus or
 I/O-interfaces
 Master/Follower bus
 Speed correction input

Power Optimization
 Max. field weakening
 factor for hoist
 calculated actual load

Brake Control
 Torque proving
 Torque memory
 Snag load
 Mechanical delay times

ABB

© Copyright 11/8/2021 ABB. All rights reserved.
CraneDriveBasicsR0101, page 20

DCC800 crane drive functions are additional to the standard DCS800 functions:

- **Logic handling:** This is the Start and stop logic, the limit software supervision, the fast stop function and the mechanical brake control.
- **Crane protections:** That means monitoring for torque, speed, field bus, mechanical brake, converter overload and torque proving. Depending on the evaluation of the protection, it causes alarms and faults.
- **Power optimization:** This calculates the maximum possible field weakening factor for the hoist and is calculated from the actual load.
- **Reference handling:** That means the I/O handling, definition of dead-zone, the S-ramp at the ramp generator and the adjustable ramp shapes.
- **Additional functions:** These are the field bus plug-in or I/O interfaces, the master-follower bus and the speed correction input.
- **Brake Control:** This includes the complete logic to lift or close a mechanical brake. Especially torque proving, torque memory and snag load.

Control the Crane Drive

- There are two ways to control a crane
 - Stand alone version via digital inputs / joystick
 - Field bus control from an overriding control system



Control of the crane drive is typically done via joystick.

There are two ways to control the crane:

- The first one is the stand-alone version where the joystick is directly connected to the digital inputs of the drive.
- The other way is to control the drive from an overriding control system.

Joystick connection to DI's

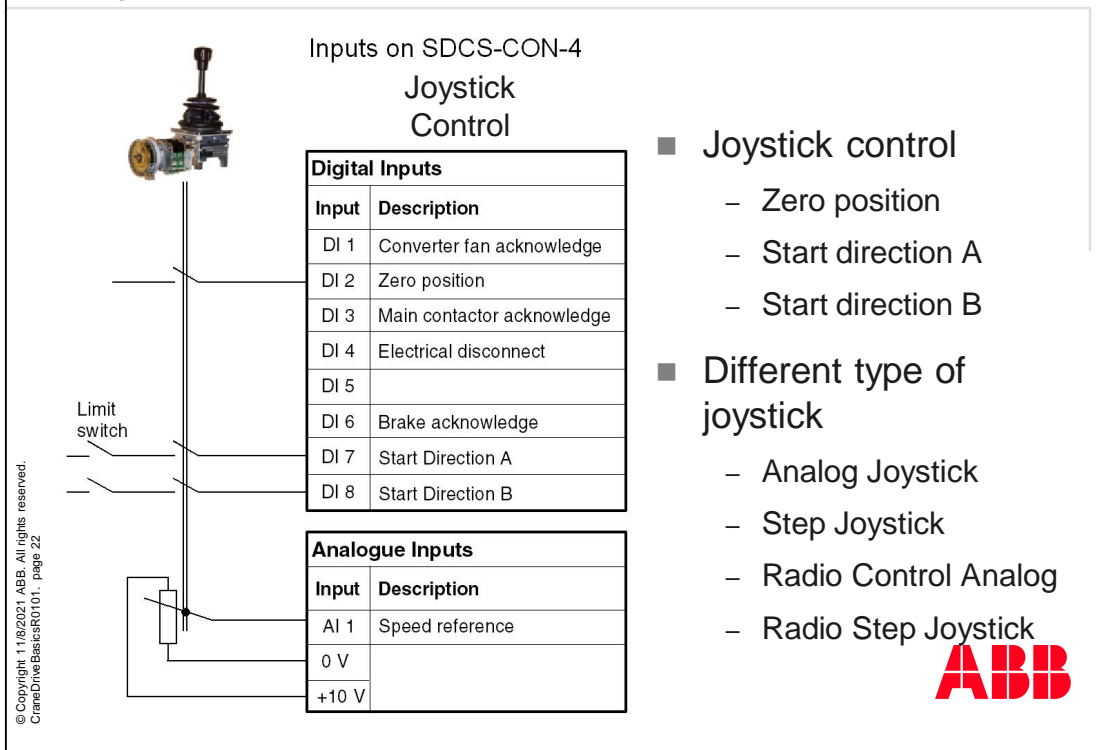

- Joystick control
 - Zero position
 - Start direction A
 - Start direction B
- Different type of joystick
 - Analog Joystick
 - Step Joystick
 - Radio Control Analog
 - Radio Step Joystick

Joystick reference is always unipolar, that means positive. The speed direction will be given by direction A and direction B signals. These digital inputs also include the information of the limit switches. The correct joystick operation is monitored by the zero position signal.

If the joystick is moved to the first direction, a signal will be sent to digital input 7 and the drive starts to operate in direction A. Moving the joystick in the opposite direction sends a signal to digital input 8 and the drive starts to operate in direction B. Also the speed reference comes from the joystick and can be connected to analog input 1.

Several types of joysticks can be connected.

An analog joystick sends an analog reference to the drive, which is scaled as a speed reference value. A step joystick only sends digital signals to the drive, which are sorted to a fixed speed reference. Radio Control Analog means to transmit an analog value from a radio receiver to the drive. Radio step means to transmit a digital signal via radio to the drive.

Joystick connection to PLC

- Joystick is connected to an external PLC
- PLC sends data words via field bus or module-bus to DCS800 converter
- Acknowledge signals going back from DCS800 to PLC
- Brake control is always inside the drive

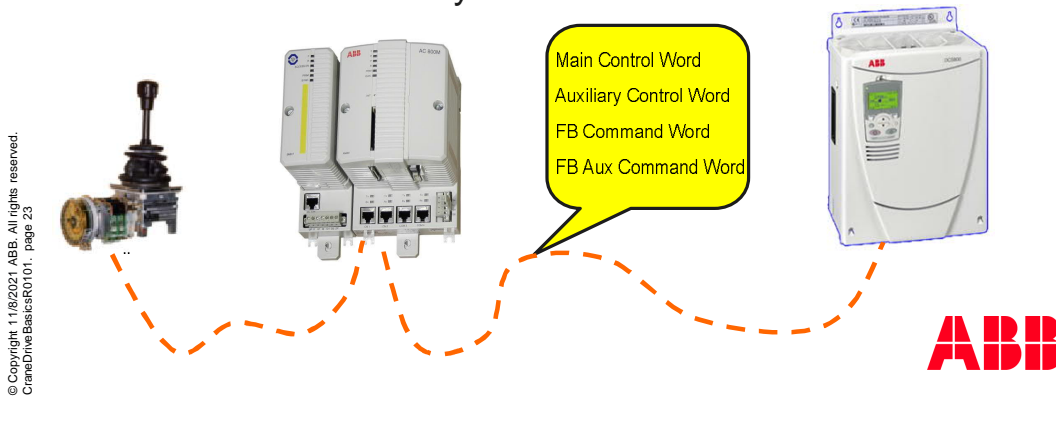

If the joystick is connected to an external PLC, then the entire joystick logic has to be programmed in the PLC. The PLC only sends data words via field bus or module-bus to the DCS800 converter. The PLC writes directly to the following DCS800 converter parameters:

- Main Control Word, parameter 7.01
- Auxiliary Control Word, parameter 7.02
- Field bus Command Word, parameter 7.10 and
- Field bus Auxiliary Command Word, parameter 7.11.

Acknowledge signals going back from the DCS800 to PLC.

Note that the brake control is always inside the drive.

Shared motion

- 2 Field exciters
- One armature bridge
- Switch: Trolley \leftrightarrow Boom
- Switch: Hoist \leftrightarrow Gantry
- DCS800 double encoder interface

RTAC option module

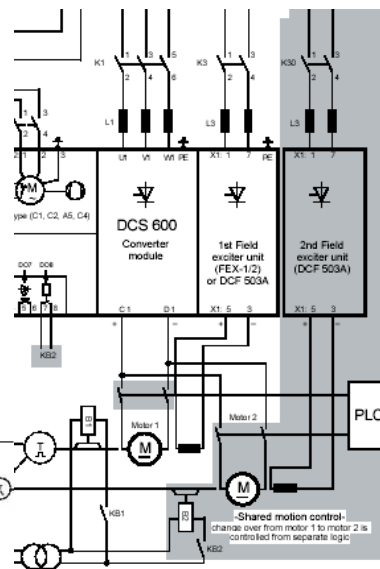
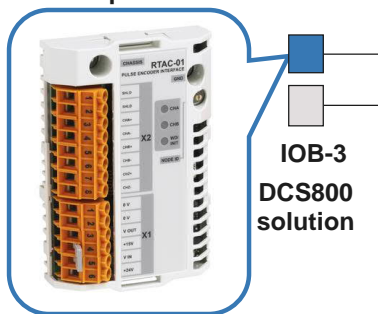

ABB

Shared motion is an important functionality for crane drives. In this configuration two field exciters are required, one for each motor. The armature converter is used twice to switch between motor 1 and motor 2.

There are two alternatives to achieve shared motion: Switching between trolley and boom and switching between hoist and gantry. This allows you to save converter space.

The DCS800 can be equipped with a double encoder interface, which can be used for the motor 1 and motor 2 encoder connection.

In comparison to classic DCS600 crane drives, there is no need for the special relay for both encoders. The DCS800 offers a second encoder input with the RTAC (r tac spoken) option module. Then encoder 1 is connected isolated to the IOB-3 board and encoder 2 also connected isolated to the RTAC option module.

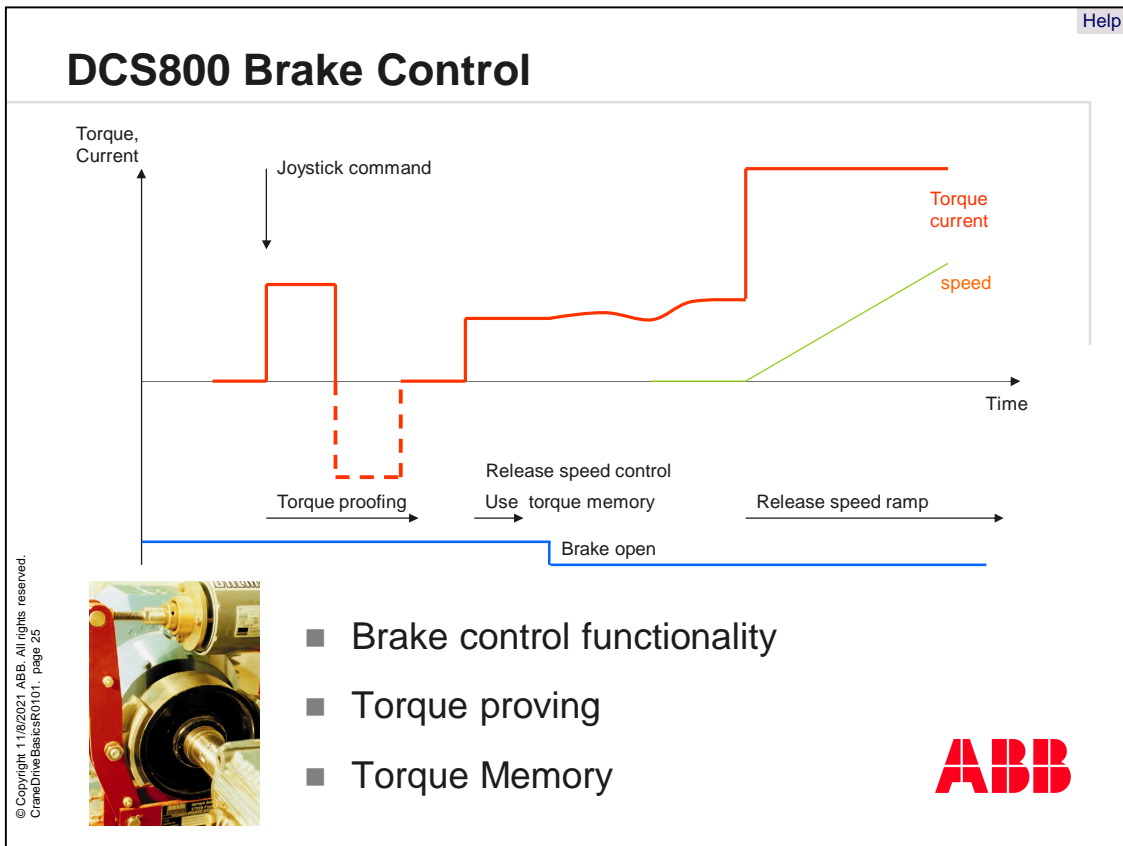

The brake control is the most important function of a hoist drive. Brake control handles delay times of the mechanical brake and ensures a smooth operation of hanging load. Brake control is implemented in the DCS800 standard firmware but enhanced with the DCC800 crane software.

Each brake opening process starts with torque proving. That means the mechanical brake is closed and a torque reference will be sent to the current controller. If the motor is able to generate torque, the torque proving was successful and the mechanical brake is ready for lifting.

Torque memory is preloading the speed controller during brake lifting to avoid any start jerk. The torque memory includes information about the last used torque depending on the load. If the brake should be opened, a start torque must be given to the torque reference before the mechanism can begin lifting.

In principle the speed ramp will release, if the start torque is present.

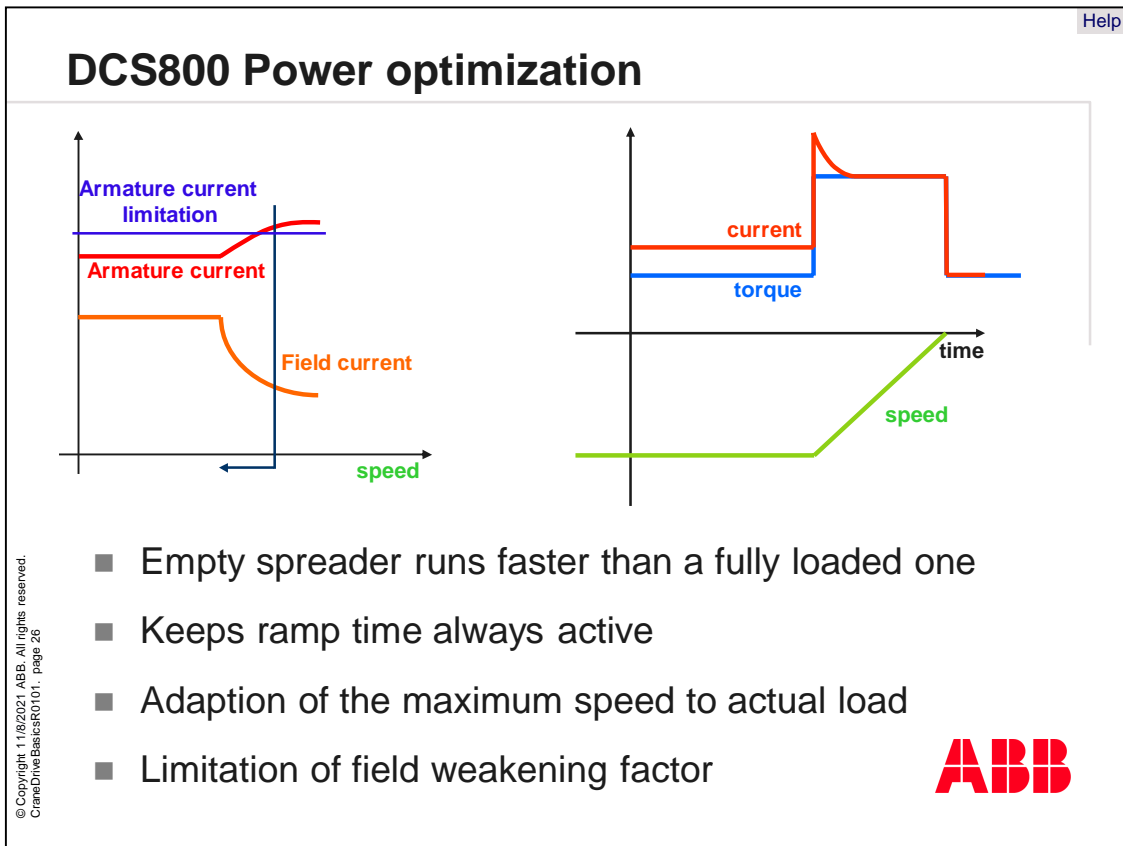

Power optimization is a typical crane functionality used to avoid motor overload. Or in other words, the motor operating point is not practicable for the load. It ensures the maximum hoist speed relative to the load.

- An empty spreader runs faster than a fully loaded one, because it can go deeper in field weakening range. The reason for this is that the motor torque needed is calculated from the load torque and acceleration torque. Therefore, the fully loaded spreader only runs up to the speed, which is possible with the speed ramp time needed.
- Power optimization is used to keep the ramp time constantly active.
- Therefore, an adaption of the speed to the actual load is needed.
- This means a limitation of the field weakening factor, which also limits the speed due to the actual load.

Power optimization is basically nothing more than motor protection. Autotuning to find parameters is available.

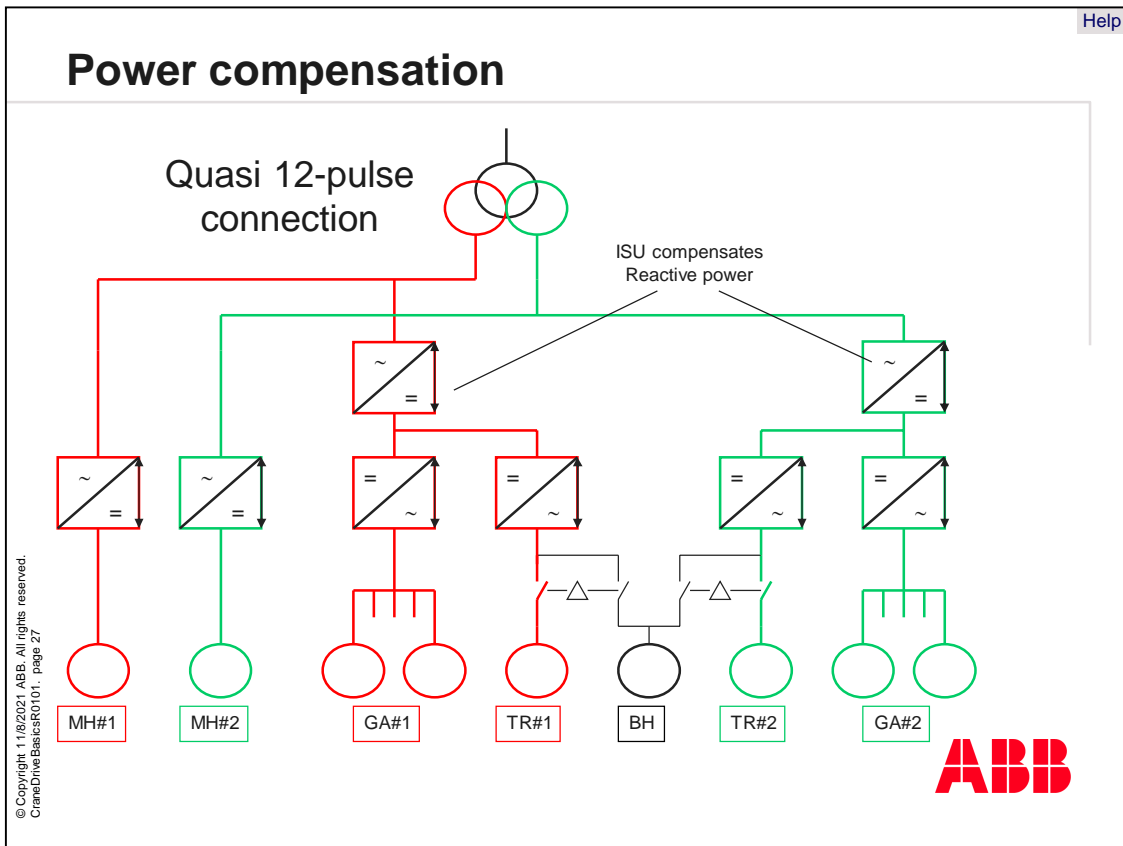

Power compensation is mainly used in a crane drive system to compensate reactive power. With an IGBT supply unit, called ISU, it is possible to compensate for the reactive power, produced by a DC drive and to reduce harmonics.

The picture shows an overview of a possible crane system. On the left side there are two DC drives, which drive the main hoist. They are connected to a power network by a 3-winding-star-delta-transformer, which is also called a quasi 12-pulse connection. The smaller drives for the gantry, trolley and boom are AC drives, which are supplied from an IGBT supply unit. The IGBT supply unit compensates the total reactive power of the complete system and reduces the total harmonics distortion.

This configuration provides minimum reactive power and minimum harmonics related to overall drive size and drive weight.

DCS800 A – Enclosure Crane Drive (layout 1500 A)

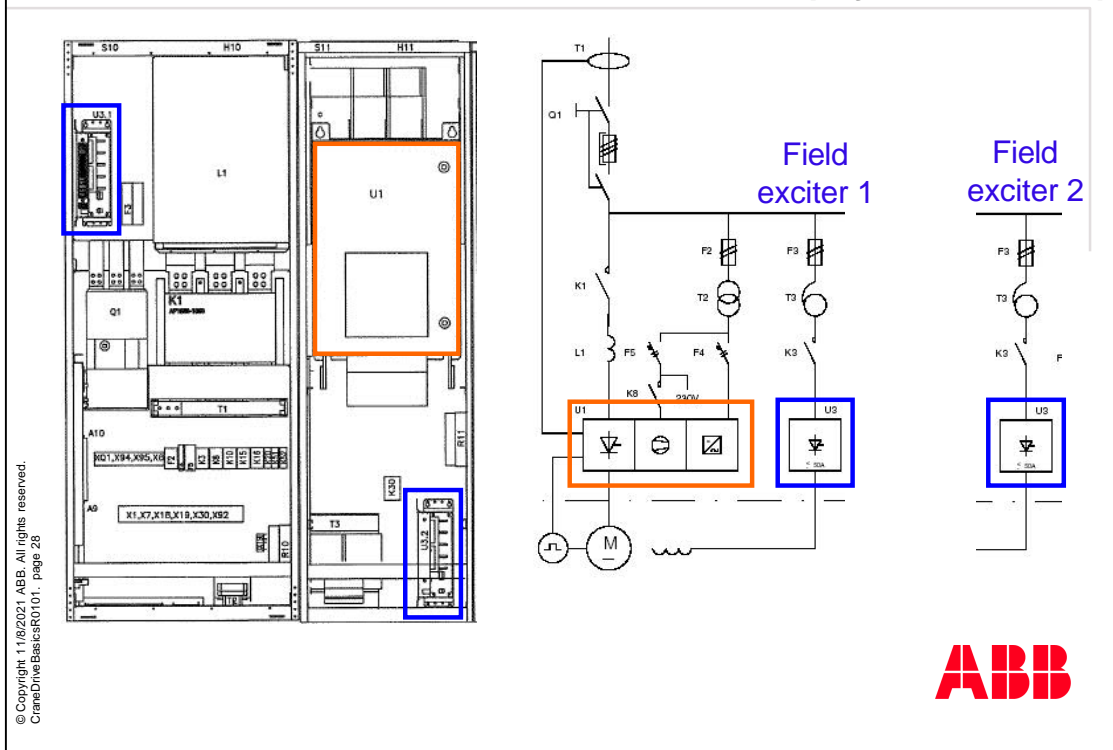

The DCS800-A crane drive layout is shown on this slide. The picture shows an example with a 1500 A converter and two field exciters for shared motion.

- The converter unit is mounted in the right cabinet on the upper side.
- The first field exciter is typically in the left cabinet on the upper side.
- The second field exciter is placed in the right cabinet on the bottom.
- The main circuit is equipped with a SACE contactor and an ISO 1250 ISOMAX protection switch. Air circuit breakers are not used.

The final cabinet design ultimately depends on the requirements and customer specifications.

DCC800 Crane Drive Ordering

- Ordering is always related to DCC800 ABB Memory Card
- Order crane Memory Card with **ID code** 3ADT 200 007
 - R301: Experts, crane club members
 - R302: None experts, not members
- Order crane Memory Card as complete drive package (inside the drive) with **plus code**
 - +S204 for expert crane club members
 - +S205 for none experts, non-members



DCC800 crane drive software can be ordered from the DC drives factory.

- Ordering is always related to the DCC800 ABB Memory Card. The crane software is stored on this card and must be plugged into the DCS800 converter. After activating the Memory Card, the drive can be used as a crane drive.
- Order the Memory Card with ID code for experts or non experts. Experts have passed an e-learning course or have completed a crane drive training. The price for experts is always lower.
- Or order the Memory Card as part of a complete drive package by plus code, which is also for experts and non experts.

Commissioning

- First the Memory Card (DCC800) which includes crane application program must be plugged in and enabled
- Please double check the version in parameter group 4
- Then the parameter set should be downloaded to DCS800 to set important parameters
- Make your own modifications for:
 - Field bus communication
 - Additional inputs and outputs
 - Crane dependent parameters



The ABB logo, consisting of the letters 'ABB' in a bold, red, sans-serif font.

Commissioning of the crane drive is described on this slide.

- First the Memory Card, which includes the crane application program, must be plugged in and enabled.
- Please double check the version in parameter group 4.
- Then the parameter set should be downloaded to the DCS800 to set the important parameters.
- The Last step is to make your own modifications for field bus communication, additional inputs and outputs and crane dependent parameters.

Summary

Key points of this module

- Types of cranes
- Important crane functions
- Ordering of DCC800 crane software

The key points of this module are:

- Types of cranes,
- Important crane functions and
- Ordering of DCC800 crane software.

Glossary (1)

- **Beam**
A rolled structural steel member, typically used as a bridge girder for short span or low capacity cranes.
- **Bogie**
A type of short end truck that is attached to the end of one girder or to a connecting member if more than one truck is utilized per girder. Bogies are used when the design of the runway necessitates more than four wheels on the crane.
- **Boom**
A mechanism mounted horizontally on the trolley of an overhead crane. A load is lowered or hoisted by the boom at a point other than directly under the hoist drum or trolley.
- **Box Section**
An enclosed, rectangular cross-section of girders, trucks or other members.
- **Bridge**
The part of an overhead crane that carries the trolley and travels parallel to the runway. Bridges consist of girders, trucks, end ties, a walkway and a drive mechanism.
- **Bridge Conductors**
An electrical conductor, at times incorrectly referred to as a "trolley conductor," that provides power and control circuits to the trolley. Bridge conductors are located along the bridge girders.
- **Cabin**
The compartment from which the operator controls the crane.
- **Camber**
The slight upward vertical curve given to girders to partially compensate for deflection due to hook load and weight of the crane.
- **Carrier**
An assembly, also called a "trolley," that supports a load and runs on a monorail track or crane girders.
- **Cover Plate**
The top or bottom plate of a box girder.
- **Dead Load**
The loads on a structure that remain in a fixed position relative to the structure.
- **Flipper**
Sensor to detect distance to container
- **Footwalk**
The walkway with handrail and toe-boards, attached to the bridge or trolley for access purposes.



Glossary (2)

- **Grab**
Grab hangs in the wires to put bulk cargo.
- **Girder**
The principal horizontal beams of the crane bridge, which support the trolley and are supported by the end trucks.
- **Hoist**
A mechanism used for lifting and lowering a load.
- **Hook**
The lifting attachment point suspended from the hoist machinery, typically single- or double-pronged. Double-pronged hooks are known as "sister hooks."
- **Idler Sheave**
A sheave used to equalize tension in opposite parts of a rope.
- **Load Block**
The assembly of hook, swivel, bearing, sheaves, pins and frame suspended by the hoisting ropes.
- **MEL (Mean Effective Load)**
A load used in durability calculations accounting for both maximum and minimum loads
- **RMG = Rail Mounted Gantry**
- **RTG = Rubber Tyre Gantry**
- **Sheave**
A grooved wheel or pulley used with a rope or chain to change direction and point of application of a pulling force.
- **Spreader**
Spreader hangs in the wires to put containers
- **Sway**
Pendulum on the spreader caused by load . Sway control means measurements taken to stop swaying.
- **Telescope**
Spreader can be adapted to container size.
- **Trolley**
The unit carrying the hoisting mechanism that travels on the bridge rails.
- **Twistlock**
Locks the container to the spreader
- **Web Plate** – The vertical plate connecting the upper and lower flanges or cover plates of a girder.





Power and productivity
for a better world™