

ELECTIVE – II ES2-1: MULTIMEDIA TECHNOLOGY

(5-Hours -5Credits)

Code: SNT8A61

UNIT I:

Multimedia Overview: Introduction, Multimedia presentation and production, characteristics of a multimedia presentation, Multiple media, Utilities of multisensory perception, Hardware and software requirements, Uses of multimedia, Promotion of multimedia based contents, steps for creating multimedia presentation.

Visual Display Systems: Introduction, cathode Ray Tube (CRT), Video Adapter Card, Video Adapter cable, Liquid Crystal Display (LCD), Plasma Display Panel (PDP).

UNIT II:

Text: Introduction, Types of Text, Unicode Standard, Font, Insertion of Text, Text compression, File Formats.

Image: Introduction, Image Types, Seeing colors, color models, Basic steps for Image processing, Scanner, Digital camera, Interface Standards, Image processing software, File formats, Image output on monitor, Image output on printer.

UNIT III:

Audio: Introduction, Fundamentals Characteristics of sound, Elements of Audio systems, Microphone, Amplifier, Loudspeaker, Audio mixer, Musical Instrument Digital Interface(MIDI), MIDI messages, MIDI connections, Sound card, Audio File format and CODECs, Software Audio Players, Audio Recording Systems, Audio and multimedia, Audio Processing software.

UNIT IV:

Video: Introduction, Analog video camera, Transmission of video signals, Video signal format, Digital video, Digital Video Standards, PC Video, Video File Format and CODECs, Video editing, Video editing software.

UNIT V:

Animation: Introduction, uses of animation, key frames and Tweening, Types of animation, Computer Assisted Animation, Creating movements, Principle of animation, some Techniques of Animation, Animation on the web, 3D Animation, Special Effects, Creating Animation, Rendering algorithms, Animation software.

Text Book:

Principles of Multimedia by Ranjan Parekh- the Tata McGraw Hill companies
Sixth Reprint 2008.

Chapters:

UNIT I:

Chapter 1-1.1, 1.2, 1.3, 1.4, 1.5, 1.6, 1.7, 1.8, 1.9

Chapter 3-3.1, 3.2, 3.3, 3.4, 3.5, 3.6

UNIT II:

Chapter 4-4.1, 4.2, 4.3, 4.4, 4.5, 4.6, 4.7

Chapter 5-5.1, 5.2, 5.3, 5.4, 5.5, 5.6, 5.7, 5.8, 5.13, 5.14, 5.15, 5.16

UNIT III:

Chapter 7-7.1, 7.2, 7.3, 7.4, 7.5, 7.6, 7.7, 7.8, 7.9, 7.10, 7.11, 7.14, 7.15, 7.19, 7.22(Up to 7.22.10), 7.23(up to 7.23.2), 7.24, 7.26, 7.28

UNIT IV:

Chapter 8-8.1, 8.2, 8.3, 8.4, 8.5, 8.6, 8.7, 8.8, 8.10(upto 8.10.4), 8.11, 8.12

UNIT V:

Chapter 9-9.1, 9.2, 9.3, 9.4, 9.5, 9.6, 9.7, 9.8, 9.9, 9.10, 9.11, 9.13, 9.14, 9.15, 9.16

Reference: Multimedia System Design by Prabhat K.Andleigh and Kiran Thakar-PHI-2008

MULTIMEDIA TECHNOLOGY

UNIT – I

Multimedia an overview: Introduction

The word ‘multimedia’ comes from the Latin words *multus* which means ‘numerous’ and *media* which means ‘middle’ or center. Multimedia therefore means ‘multiple intermediaries’ or ‘multiple means’.

Multimedia is a combination of following elements. They are

- Text (e.g. books, letters, newspapers)
- Images and graphics (e.g. photographs, charts, maps, logos, sketches)
- Sound (e.g. radio, gramophone records and audio cassettes)
- Video and animation (e.g. TV, video cassettes and motion pictures)

Multimedia Presentation and Production:

The multimedia presentation is basically a digital show in which the contents are expressed through various media types like text, images, audio, video etc., The end users who execute and watch the presentation are called viewers or target audience. The multimedia presentation is basically playback on a personal computer either from hard disk or the CD-ROM. Sometimes when the audience consists of the large number of people, the presentation may be projected on a big screen using a projection system. Before a presentation can be viewed, however it has to be created. This process is known as multimedia production.

The production work is carried out by a team of professionals equipped with the required skills and knowledge. These professionals are called the developers or the authors and the development work is called the authoring.

Characteristics of Multimedia presentation:

Multimedia is any combination of text, graphics, art, sound and video elements. The following are the important characteristics of Multimedia presentation. They are

- Multiple media
- Non-linearity
- Interactivity
- Digital representation
- Integrity

MULTIPLE MEDIA:

In addition to text, pictures are also started being used to communicate ideas. Pictures were sub-divided into two types.

- I. A real-world picture captured by a camera is called images.
- II. A hand-drawn picture like sketches, diagrams and portraits called graphics.

Text, images and graphics are together referred to as static elements, because they do not change overtime. With further improve in technology, time varying elements like sound and movies were used. Movies are again divided into two classes. They are

- ❖ Motion pictures
- ❖ Animation

Legitimate multimedia presentation should contain at least one static media like text, images or graphics and at least one time varying media like audio, video or animation.

NON-LINEARITY:

Non-Linearity is the capability of jumping or navigating from within a presentation with one point without appreciable delay. TV shows and motion pictures are considered linear presentation because the user or viewer has to watch the information being prescribed. The user cannot modify the content.

In a multimedia presentation the user can instantly navigate to different parts of the presentation and display the frames in any way, without appreciable delay, due to which it is called a non-linear presentation.

INTERACTIVITY:

In a non-linear presentation user will have to specify the desire to watch the presentation. The presentation should be capable of user inputs and capable of change the content of the presentation. Interactivity is considered to be one of salient features on which next generation e-learning tools are expected to reply for greater effectively.

DIGITAL REPRESENTATION:

Magnetic tapes are called the sequential access storage devices (i.e.) data is recorded sequentially along the length of the tape. When a specific potion of the data is required to be played back, the portion before that needs to be skipped.

Multimedia requires instant access to different portion of the presentation. This is done by random access storage devices like hardware, floppy disks, and compact disks. Digital representations has other advantages, software based programs can be used to edit the digitized media in various ways to appearances and compress the file sizes to increase the performance efficiency.

INTEGRITY:

An important characteristic of a multimedia presentation is integrity. This means that although there may be several media types present and playing simultaneously, they need to be integrated or be part of a single entity which is the presentation. It should not be able to separate out the various media and control them independently; rather they should be controlled from within the frame work of the presentation. Moreover, the presentation should decide how the individual elements can be controlled.

UTILITIES OF MULTISENSORY PRECEPTION:

The benefits of multisensory systems are manifold.

- (i) The interaction with the computer system may appear more natural and friendly.
- (ii) Useful redundancy of information may be possible.
- (iii) Complementary information presented together may improve memorization of knowledge. Also the fact, that the user interacts with the presentation leads to greater retentivity of information.
- (iv) Emotional information is easier to convey. Multi-sensory systems may be invaluable benefits to users with special needs.
- (v) The enrich, the set of media which stimulate the given sense. Rich text, graphics and video are the example of visual media
- (vi) They introduce media which stimulate new senses like audio in the form of human speech and music

HARDWARE & SOFTWARE REQUIREMENTS:

Hardware and software requirements of a multimedia personal computer can be classified into two classes. They are:

- a. Multimedia playback
- b. Multimedia production

Multimedia playback:

- ❖ **Processor** – At least Pentium class and minimum of 8MB RAM-to-32MB RAM.
- ❖ **Hard disk drive(HDD)** – Atleast 540MB having 15M/s. access time and should be able to provide 1.5MB per second sustained throughput.
- ❖ **The monitor and video display adapter** should conform through SVGA standards and support 800x600 display modes with true color.
- ❖ **CD-ROM drives** having a speed of at least 4X but highest speed like 36X are recommended.
- ❖ PC should have a **sound card** with attached speakers standard 101 keys keyboard and mouse.
- ❖ Multimedia PC system software should be compatible with windows 95 or higher, with standard software with playback of media files in standard formats.(e.g.) Windows Media Player.

Multimedia production:

- ❖ **Processor - Pentium II** or higher, memory should be at least 128MB with 256MB recommended.
- ❖ **Hard disk drive (HDD)** – Typical requirements would be around 10GB with 40GB recommended.
- ❖ **The monitor and video display adapter** should conform through SVGA standards and should be able to support 800x600 display mode with true color, RAM should be 4MB to 8MB.
- ❖ **CD-ROM drive** having a speed of at least 4X to 36X, PC should have a CD writer.
- ❖ PC should have a **sound card** with attached speakers standard 101 keys keyboard and mouse.
- ❖ Multimedia PC system software should be compatible with windows or higher, with standard software with playback of media files in standard formats. (e.g.) Windows Media Player.

- ❖ **Editing software** is used to manipulate media components to suit the developers, requirements. (e.g.) Adobe Photoshop, Flash, Cool Edit, and sound Forge.
- ❖ **Authoring softwares** are used to integrate all the edited media into single presentations and build navigational pathways for accessing the media.
- ❖ To display the web content **web browsers** will be required. (e.g.) MS Internet Explorer, to create web content HTML, and java Script editors might be required (e.g.) Macromedia, dream viewer.

USES OF MULTIMEDIA TECHNOLOGY:

Multimedia has found extensive applications in various and varied fields. The following are some of the main areas where this technology is applied.

- Home entertainment
- Educational purposes
- Industrial training
- Information kioks
- Corporate presentations
- Business
- Tourism and Travel industry
- E – Shopping
- Communication and networks
- Medicine
- Engineering Application
- Content based storage and retrieval (CBSR) systems.

Home Entertainment:

Application of Multimedia technology related to home entertainment includes computer based games for kids, interactive encyclopedia's, storytelling, cartoons etc., Computer games are one of the best application of Multimedia because of the high amount of interactivity involved.

Educational purposes:

These applications include learning packages and simulation of lab experiments (especially those which cannot be easily performed). The multisensory perceptions of such study material are expected to provide a good grasp of the subject matter and interactivity elements to provide for better retention.

Industrial Training:

These applications involve computer based training (CBT) for employee both technical and marketing. Successful organizations are required t maintain a high level of staff training and development. Some of the advantages of industrial training courses are:

- (i) Many people can use each of these courses.
- (ii) They do not need to spend time away from office.

- (iii) People can learn at their own pace.
- (iv) Full time instructions are not required.
- (v) Because the best instructors could be used to make these CBT's they could be of a high quality.

Information kios:

These are devices where information is accessed through a touch screen and viewed on a monitor. Examples can be include multi-lingual product, catalog's for placing orders or for dispensing important information Bio's can also be used to capture statistical data for an in-depth marketing research to be carried out on customer trends.

Corporate presentations:

Corporate presentations are emphasizing the salient features and activities of a company, its products, business partners like suppliers and retailers can be built by incorporate multimedia elements along with textual descriptions.

Business:

Items like glass utensils are difficult to stock; industrial equipment can be displayed through perspectives buyers by company sales people through multimedia presentations.

Tourism and Travel industries:

Travel companies can market packaged tools by showing prospective customers, glimpses of the places they would like to visit, details on lodging, fooding, special attractions. A multimedia system implementing intelligent travel agent software will enable the user to their travel need and budget.

E-shopping:

Like the travel industry, customized presentations for consumer and industrial products can be created and distributed to prospective customers. Customers can compare different products in relation to their quality, price, and appearances without leaving their homes and offices.

PROMOTION OF MULTIMEDIA BASED CONTENT:

For promotion of multimedia based application and presentations, so as to capture an appreciable sector of the IT marketplace, the following at least should be present:

- (i) Demand from Customer
- (ii) Compression Techniques
- (iii) Processing power
- (iv) Standards
- (v) Bandwidth
- (vi) Distribution mechanism

Demand from customers:

If the customer is to invest additional amount is acquiring multimedia based content, then the customer will see how much they can fulfill their requirements. There should be appreciable value addition factor provided by the multimedia application, something that the normal print media cannot fulfill.

Compression Techniques:

Non-Textual digital media, usually occupy a lot of disk space. While several text pages of a document occupy few kilobytes (kb), full screen images have sizes in the range of few megabytes, audio content occupy Ten's of megabytes while video content can span Gigabytes. It is difficult to manipulate these large files in their original form, so they need to be compressed to reduce their sizes. Efficient compression techniques should be present to make this possible.

Processing power:

Dynamic media like audio, video, and animation require the central processor and screen display system to process a large quantity of data, every second. 3D animation requires a large number of floating point calculation to be performed every second.

Standards:

The need for standard cannot be overemphasized standard guarantee the interoperability. These include both hardware and software standards like buses, cables, connectors, signals, file formats, data transmission protocols, compression and de-compression techniques.

Bandwidth:

A powerful processing machine and large files sizes also means that a large amount of data need to transferred at high speed between devices or components. This requires high bandwidth and data rates between internal and external components of a system. For example, in 1 second 44100 elementary samples of digital audio are to be playback from an audio CD for a faithful representation of the original sound.

Distribution mechanism:

After creation of multimedia content need to distribute effortlessly to the customer. Portable storage media supporting high storage volumes are essential for this distributed mechanism. A majority of the multimedia content are distributed via CD-ROM, which additionally provide high durability of the content.

STEPS FOR CREATING A MULTIMEDIA PRESENTATION:

Here are the basic steps for creating a multimedia presentation.

- (i) Choosing a Topic
- (ii) Writing a Story
- (iii) Writing a Script
- (iv) Preparing a Storyboard
- (v) Preparing a flow line
- (vi) Implementation
- (vii) Testing and Feedback
- (viii) Final Delivery

Choosing a Topic:

The first topic/task is to choose a topic on which to create the presentation. In principle, one can select any topic; topics which can be explained or demonstrated using various media types are more conducive to multimedia presentation. Use of text is not prohibited, but should be kept at a minimum. For example, not more than a few lines per page of the presentation when choosing a topic one should make a mental note, of how the subject matter should be divided and what entry points should give access to which module. The author should also decide who should be the target audience. The author should also decide the objectives of the presentation (i.e.) what the audience is expected to learn after going through presentation.

Writing a script:

Once the overall subject matter has been finalized, the next step is to create a script. A script emphasizes how the subject matter unfolds. While writing a script, the author visualizes the content in terms of frames. For example, what is to be displayed on the first screen? This requires the subject matter of the story be divided into small modules one for each screen. The script could also include other accessory information like how the elements are displayed on the screen.

Preparing a Storyboard:

Once the script has been prepared, the author needs to prepare the storyboard. The storyboard depicts what should be the layer of each screen within the presentation. The screen should have an aesthetic feel about them and should be pleasant to look.

Preparing a flow line:

Along-side a storyboard, the author should also prepare a flow line. A flow line at a glance tells us how the user can access different pages of the presentation.

Implementation:

Implementation needs actually creating the physical presentation using required hardware and software. Implementation has a number of sub steps. The first step is the collection of media items. The author can use software to create their own items. There are two types of implementation software.

- (i) The first type is the editing software, which are used to edit the digitized items.
- (ii) The second type of softwares is the authoring software; which are used to integrate all the editor media into a single presentation. The output of the authoring software is usually an executable file (.exe) which contains its own runtime engine and therefore can be played without the help of any other software.

Testing and feedback:

After the implementation phase is completed, an important step of testing and feedback should be done for improving the quality of the presentation. This step involves distributing whole (or) part of the presentation to sections of the target audience and heading the feedback from them about the possible areas which need improvement. Developers always work under various constraints and do not have indefinite time on their hands.

Final delivery:

The final phase in the production schedule is the delivery of the application to be intended client. Usually the runtime version of the application files are copied into a CD-ROM and physically handed over to the customer. It is also important for the author to state clearly the hardware and software requirements which should be present on the client machine to run the application smoothly.

VISUAL DISPLAY SYSTEMS

The primary user interface hardware for displaying these visual media like text, image, graphics, video, and animation is a visual display system. The visual display system contains following three components.

- (i) Monitor, where we view the visual media and the final presentation.
- (ii) Video adapter card, an expansion card serving as an interface between the processor and the monitor.
- (iii) Video adapter cable, which connects and transmits signals between the adapter card and the monitor.

CATHODE RAY TUBE: (CRT)

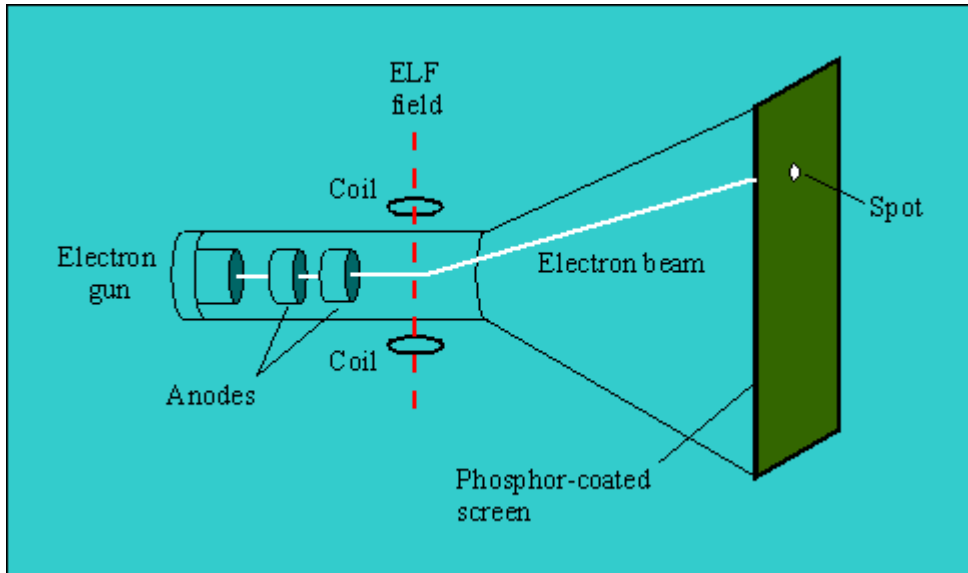

Monochrome CRT:

CONSTRUCTION AND WORKING PRINCIPLE:

The most common type of monitor used with the multimedia desktop system is based on picture tube called the cathode ray tube (CRT). It is essentially a vacuum sealed glass containing two electrodes, the cathode or negative electrode and the anode or positive electrode. The front face of the tube is coated with a chemical compound called phosphor arranged in the form of rectangular grid of a large number of dots. The material phosphor has a property of emitting glow of light when it is hit by charged particles like electrons. The phosphor dots called pixels, sort for picture elements are responsible for producing an image on the monitor. Other positive electrodes called grids (G1, G2, and G3) are located near the cathode. Near the neck of the CRT are two coils of wire known as the deflection coils. Electron E^- beams generated from the cathode are made to hit the phosphor dots generating spots of light and thereby producing the image.

A CRT capable of producing a black and white image on the screen is called a monochrome CRT. A high voltage of order of 18kv is maintained between the cathode and anode. This produces a beam of e^- , known as cathode rays from the cathode towards the anode. The beam of electrons is

controlled by 3 other positive terminals. The control grid G1, helps to control the amount of electrons in the beam, the acceleration grid G2, provides acceleration of electrons in the forward direction and focusing grid G3, focuses the beam to a single point 'X' on the screen ahead, so that the diameter of the beam is equal to the diameter of a single phosphor dot.

As the beam hits, the phosphor dot, a single glowing spot of light is created at the center of the screen. This spot of light is known as glowing pixels. When current flow through the deflection coil, the electric field produced interacts with the e^- beam thereby deflecting it from its original path to another point y.

One of the coils called the horizontal deflection coil moves the beam horizontally across the screen & other coil called vertical deflection coil moves the beam vertically along the height of the screen. When both these coils are energized required proportions the e^- beam can be moved in any direction. Thus generating a single spot of light at any point on the CRT screen.

COLOR CRT:

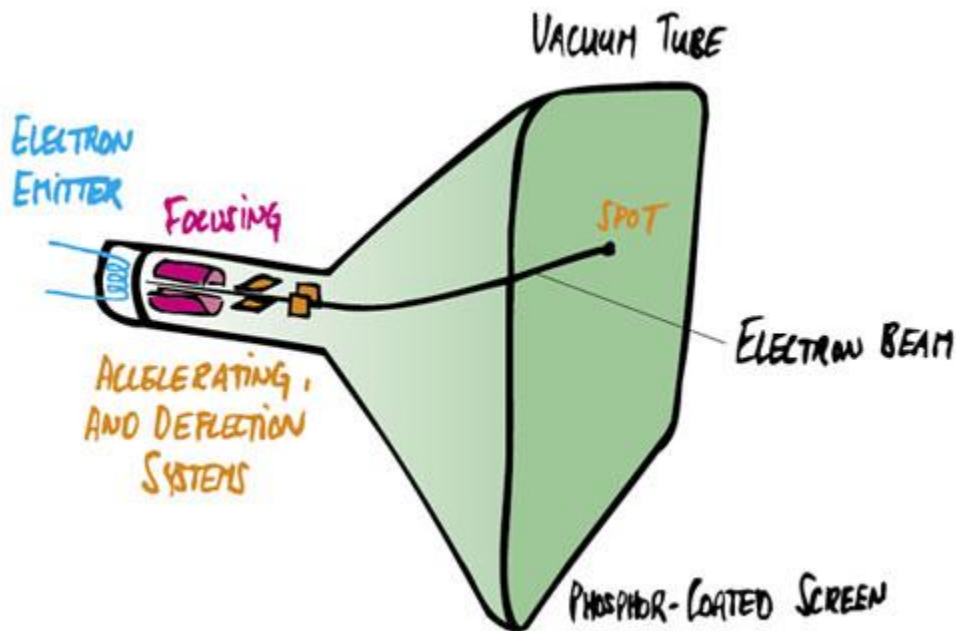

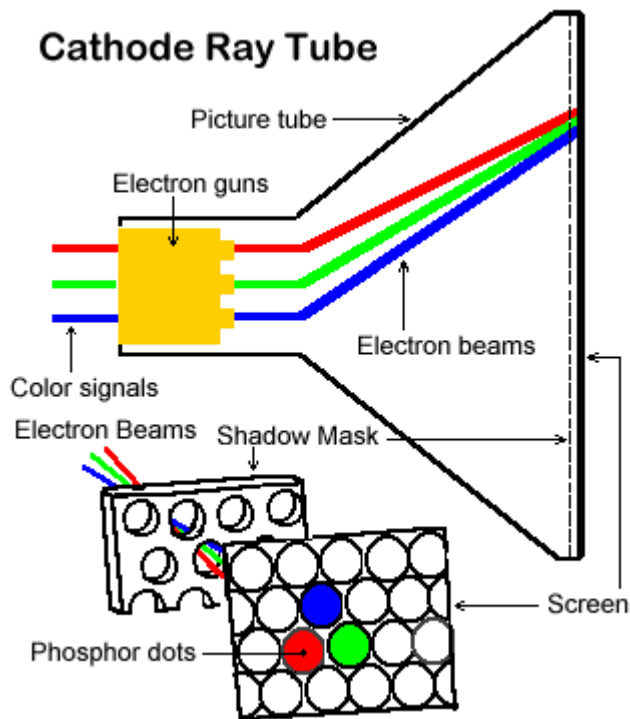

The working principle of a color CRT is similar to that of a monochrome CRT, except that here each pixel consists of three colored dots instead of one and is called a triad. These processed phosphor produce lights of color red, green and blue (RGB) and are called primary colors. These are so called because it has been experimentally observed that these three colored lights can combine in various proportions to produce all other colors.

Corresponding to the three dots these e^- beams from the electrode (also called e^- -gun), each of which falls on the corresponding dots in various intensity; they produce different proportions of three elementary colored lights which mix together to create the sensation of a specific color in our eyes.

A perforated screen called a shadow mask prevents the beam from falling in the gap between the dots. As the e^- beam sweeps across the shadow mask, it gets heated up due to e^- -bombardment on it. Expansion due to heating may disturb the alignment of the holes with the phosphor dots, thereby causing the mask to lose its utility. To prevent this, the mask is made up of a special alloy of Iron and nickel called invar which does not expand on heating.

VIDEO ADAPTER CARD:



Functions of an Adapter Card:

The video adapter card is an expansion card which usually sits on a slot on the motherboard. It acts as the interface between the processor and the monitor. It accepts the data from the processor through a communication channel called the bus, which connects to the slot. The card communicates with the monitor via the adapter cable through a 15-pin connector.

The digital data required for creating an image on the screen is generated by the central processor of the computer and consists of RGB values for each pixel on the screen. These are called pixel attributes.

Earlier generation video cards can only passively transfer these data to the monitor and were called flat video cards. For example, the adapter card can handle movement of an object on the screen. For this involves changing existing pixel values, but to display a second object on the screen it needs to get additional data from the processor.

Due to this additional capability, the modern video card releases computing and load from the processor can display changing scenarios the presence of a processor chip on the card itself. Thus, they are also referred to as accelerated video cards.

ESSENTIAL COMPONENTS OF A VIDEO ADAPTER CARD:

The video adapter card contains a number of essential components for converting the digital data from the processor into analog signals before sending them to the monitor. The following are the essential components of adapter card. They are

- (i) Display memory
- (ii) Graphics controller
- (iii) Digital to Analog convertor.

Display Memory:

A bank of memory within the adapter card used for storing pixel attributes. Initially used for storing the image data from the CPU and later used by the adapter to generate RGB signals for the monitor. The amount of memory should be sufficient to hold the attributes of all the pixels on the screen. The display memory is also known as Video RAM (VRAM).

Graphics controller:

A chip within the adapter card, responsible for co-coordinating the activities of all other components of the card. For the earlier generation video cards, the controller simply passed on the data from the processor to the monitor.

Digital to Analog converter :(DAC)

The DAC is one the main reason why the adapter is there. It takes the final digital data from the VRAM and converts it to analog signals before sending those outwards to the monitor. Since the electron guns of the monitor need voltage signals to generate electron beams, they would not be able to function if digital data is directly fed to them. The digital data stored in the VRAM describes the pixel attributes needed to drawn image on the monitor. The DAC converts these pixels values into voltage signals.

VIDEO ADAPTER



CABLE:

The video adapter card is connected to the monitor with the video adapter cable. The cable plugs to the card using a 15-pin connector. It carries the video signals (one for monochrome and three for color) from the adapter card to the monitor where these are used to activate the e-beams of e-gun.

Additionally the cable also carries two synchronization signals(horizontally & vertical) which are fed to the deflection coils on the neck of CRT to control the movement of the electron beams. All these signals are generated by the adapter card in such a way that the monitor can reproduce the image described by the pixel attributes stored in VRAM.

LIQUID CRYSTAL DISPLAY :(LCD)

The liquid crystal is a transparent organic substance consisting of long rod-like molecules. It was found that the substance has properties for manipulating direction of light rays flowing through it. This property is utilized for using it in display devices.

Advantage of the LCD is that its power consumption is much less than that of the CRT. This makes it ideal to be operated by batteries. It is however much more expensive than the CRT and more difficult to manufacture.

Construction and working principle:

An LCD monitor is a collection of LCD elements, each element generating a pixel on the screen, analogous to the phosphor dots on a CRT screen. An LCD element consists of two major components.

- ❖ A layer of liquid crystal sandwiched between two finely grooved surfaces with their grooves perpendicular to each other.
- ❖ Two optical polarizing filters perpendicular to each other.

By flowing the liquid crystal over a finely grooved surface it is possible to control the alignment of the molecules as they follow the alignment of the grooves. A layer of liquid crystal material is placed in a container with two finely grooved surfaces whose grooves are perpendicular to each other and those at the intermediate layers are twisted by intermediate angles.

Natural light waves are oriented at random angles and flow along various plane from the light source. An optical polarizing filter or polarizer can involve a single plane of light from the collection. The filter acts as a net of finely parallel lines blocking all light except those flowing in a parallel to the lines. The light in this condition is said to be polarized. A second polarizer whose lines are perpendicular to the first would block all the polarized light.

The container with grooved surfaces is placed in between two perpendicular polarized filters. Normally light from the first filter would be blocked by the second filter. However in this case, the liquid crystal material placed in between twists the plane of light by 90 degrees as it passes through the material due to its molecular alignments. The light now is parallel to the second filter and comes out wholly through it to the eye of the observer. This constitutes a lighted pixel on the screen.

A battery connected across the liquid crystal container generates a current through the liquid crystal, and re-orientates its molecules according to the direction of the current flow. This distributes the orderly pattern of the liquid crystal molecules; so that now the molecules at the grooved surfaces are no longer emerge. An observer on the other side of the filter does not see any light coming out. This arrangement creates a dark pixel.

PLASMA DISPLAY PANEL: (PDP)

Plasma is also called ionized gas. Plasma is an energetic gas-phase state of matter, often referred to as 'the fourth state of matter', in which some or all of the electrons in the outer atomic orbital have become separated from the atom. The result is a collection of ions and electrons which

are no longer bound to each other. Because these particles are ionized (charged), the gas behaves in a different fashion than neutral gas e.g., it can be affected by electromagnetic fields.

Construction and working principle:

Other than CRT and LCD, a third type of display screens often used is known as the plasma Display Panel (PDP). A PDP is an emissive (i.e. discharge of electromagnetic radiation or particles) flat panel display where light is created by phosphor excited by a plasma discharge between two flat panels of gases. The gases used are usually mixture of inert gases like neon and xenon.

A PDP usually produces an excess of 1000 lux (a lux is an unit of illumination equal to one lumen per square meter) of illumination. By comparison sunlight on a average day ranges from 32K lux to 100k lux, TV studios are lit at 1000 lux, a bright office has 400 lux, moonlight represents 1 lux, starlight measures 50m lux. More over PDP can have large sizes, about 80" diagonally.

Plasma displays, like CRT television, are phosphor-based, meaning they rely on glowing phosphor to create their images. A plasma panel starts with two sheets of 1/16" glass. Between the sheets of glass are spacers that create their images. A Transparent electrodes are then coated inside the front and back pieces of glass (the rear electrode is called 'the address electrode'), so that there are two electrodes per cell on the front piece of glass and one electrode per cell on the rear piece of glass. Next each cell is coated with phosphor and filled with a mixture of neon and xenon gases. Note that the entire structure is sealed so that the gas will not escape. When an electrical charge is added to the front and back electrodes, a voltage differential is created, adding energy to the gas mixture and changing the gas to a plasma state. Once the gas changes into a plasma state, it releases ultraviolet energy which excites the phosphor coated inside each cell, causing it to emit visible light.

UNIT – II

Text: Introduction

In multimedia presentations, text can be combined with other media in a powerful way to present information and express moods. Text can be of various types:

- **Plaintext**, consisting of fixed sized characters having essentially the same type of appearance.
- **Formatted text**, where appearance can be changed using font parameters
- **Hypertext**, which can serve to link different electronic documents and enable the user to jump from one to the other in a non-linear way.

Internally text is represented via binary codes as per the **ASCII table**. The ASCII table is however quite limited in its scope and a new standard has been developed to eventually replace the ASCII standard. This standard is called the **Unicode** standard and is capable of representing international characters from various languages throughout the world.

We also generate text automatically from a scanned version of a paper document or image using Optical Character Recognition (**OCR**) software.

TYPES OF TEXT:

There are three types of text that can be used to produce pages of a document:

- Unformatted text
- Formatted text
- Hypertext

I. Unformatted Text:

Also known as plaintext, this comprise of fixed sized characters from a limited character set. The character set is called **ASCII table** which is short for American Standard Code for Information Interchange and is one of the most widely used character sets. It basically consists of a table where each character is represented by a unique 7-bit binary code. The characters include a to z, A to Z, 0 to 9, and other punctuation characters like parenthesis, ampersand, single and double quotes, mathematical operators, etc. All the characters are of the same height. In addition, the ASCII character set also includes a number of control characters. These include BS

(backspace), LF (linefeed), CR (carriage return), SP (space), DEL (delete), ESC (escape), FF (form feed) and others.

II. Formatted Text:

Formatted text are those where apart from the actual alphanumeric characters, other control characters are used to change the appearance of the characters, e.g. bold, underline, italics, varying shapes, sizes, and colors etc., Most text processing software use such formatting options to change text appearance. It is also extensively used in the publishing sector for the preparation of papers, books, magazines, journals, and so on.

III. Hypertext:

The term Hypertext is used to mean certain extra capabilities imparted to normal or standard text. Like normal text, a hypertext document can be used to reconstruct knowledge through sequential reading but additionally it can be used to link multiple documents in such a way that the user can navigate non-sequentially from one document to the other for cross-references. These links are called **hyperlinks**.

Microsoft Home Page

The underlined text string on which the user clicks the mouse is called an **anchor** and the document which opens as a result of clicking is called the **target document**. On the web target documents are specified by a specific nomenclature called Web site address technically known as **Uniform Resource Locators** or URL.

Node or Anchor:

The anchor is the actual visual element (text) which provides an entry point to another document. In most cases the appearance of the text is changed from the surrounding text to designate a hypertext, e.g. by default it is colored blue with an underline. Moreover the mouse pointer changes to a finger icon when placed over a hypertext. The user usually clicks over the hypertext in order to activate it and open a new document in the document viewer. In some cases instead of text an anchor can be an image, a video or some other non-textual element (**hypermedia**).

Pointer or Link

These provide connection to other information units known as **target** documents. A link has to be defined at the time of creating the hyperlink, so that when the user clicks on an anchor the appropriate target document can be fetched and displayed. Usually some information about the target document should be available to the user before clicking on the anchor. If the destination is a text document, a short description of the content can be represented.

UNICODE STANDARD:

The Unicode standard is a new universal character coding scheme for written characters and text. It defines a consistent way of encoding multilingual text which enables textual data to be exchanged universally. The Unicode standard goes far beyond ASCII's limited capability by providing the capacity of encoding more than 1 million characters. The Unicode standard draws a distinction between **characters**, which are the smallest component of written language, and **glyphs**, which represent the shapes, the characters can have when displayed.

Some of the languages and their corresponding codes are: Latin (00), Greek (03), Arabic (06), Devanagari/Bengali (09), Oriya/Tamil (0B), etc. Several methods have been suggested to implement Unicode based on variations in storage space and compatibility. The mapping methods are called **Unicode Transformation Formats (UTF)** and **Universal Character Set (UCS)**. Some of the major mapping methods are:

a) **UCS-4,UTF-32**

Uses 32-bit for each character. The simplest scheme as it consists of fixed length encoding, how it is not efficient with regard to storage space and memory usage, and therefore rarely used. Initially the UCS-4 was proposed with a possible address range of 0 to FFFFFFFF, but Unicode requires only upto 10FFFF.

b) **UTF-16**

A 16-bit encoding format. In its native format it can encode numbers upto FFFF, i.e, as xxxxxx xxxxxx. For codings beyond this, the original number is expressed as a combination of two 16-bit numbers.

c) **UTF-8**

The bits of a Unicode character is divided into a series of 8-bit numbers. The output code against various ranges of input codes are given in Table 4.1

Code range	Input code	Output code
000000-00007F	Xxxxxxx	0xxxxxxx
000080-0007FF	xxx xxxxxxxxx	110xxxx 10xxxxxxx

FONT: Insertion of Text

Text can be inserted in a document using a variety of methods. These are:

1) Using a keyboard

The most common process of inserting text into a digital document is by typing the text using an input device like the keyboard. Usually a text editing software, like Microsoft Word, is used to control the appearance of text which allows the user to manipulate variables like the font, size, style, color, etc.,

2) Copying and Pasting

Another way of inserting text into a document is by copying text from a pre-existing digital document. The existing document is opened using the corresponding text processing program and portions of the text may be selected by using the keyboard or mouse. Using the **Copy** command the selected text is copied to the clipboard. By choosing the **Paste** command, whereupon the text is copied from the clipboard into the target document.

3) Using an OCR Software

A third way of inserting text into a digital document is by scanning it from a paper document. Text in a paper document including books, newspapers, magazines, letterheads, etc. can be converted into the electronic form using a device called the scanner. The electronic representation of the paper document can then be saved as a file on the hard disk of the computer. To be able to edit the text, it needs to be converted from the image format into the editable text format using software called an Optical Character Recognition (OCR). The OCR software traditionally works by a method called **pattern matching**. Recent research on OCR is based on another technology called **feature extraction**.

TEXT COMPRESSION:

Large text documents covering a number of pages may take a lot of disk space. We can apply compression algorithms to reduce the size of the text file during storage. A reverse algorithm must be applied to decompress the file before its contents can be displayed on screen. There are two types of compression methods that are applied to text as explained:

a. **Huffman Coding:**

This type of coding is intended for applications in which the text to be compressed has known characteristics in terms of the characters used and their relative frequencies of occurrences. An optimum set of variable-length code words is derived such that the shortest code word is used to represent the most frequently occurring characters. This approach is called the **Huffman** coding method.

b. **Lempel-Ziv (LZ) Coding**

In the second approach followed by the **Lempel-Ziv** (LZ) method, instead of using a single character as a basis of the coding operation, a string of characters is used. For example, a table containing all the possible words that occur in a text document, is held by both the encoder and decoder.

c. **Lempel-Ziv-Welsh (LZW) Coding**

Most word processing packages have a dictionary associated with them which is used for both spell checking and compression of text. The variation of the above algorithm called **Lempel-Ziv-Welsh** (LZW) method allows the dictionary to be built up dynamically by the encoder and decoder for the document under processing.

FILE FORMATS:

The following text formats are usually used for textual documents.

- **TXT (Text)**

Unformatted text document created by an editor like Notepad on Windows platform. This documents can be used to transfer textual information between different platforms like Windows, DOS, and UNIX,

- **DOC (Document)**

Developed by Microsoft as a native format for storing documents created by the MS Word package. Contains a rich set of formatting capabilities.

- **RTF (Rich Text Format)**

Developed by Microsoft in 1987 for cross platform document exchanges. It is the default format for Mac OS X's default editor TextEdit. RTF control codes are human readable, similar to HTML code.

- **PDF (Portable Document Format)**

Developed by Adobe Systems for cross platform exchange of documents. In addition to text the format also supports images and graphics. PDF is an open standard and anyone may write programs that can read and write PDFs without any associated royalty charges.

- **PostScript (PS)**

Postscript is a **page description language** used mainly for desktop publishing. A page description language is a high-level language that can describe the contents of a page such that it can be accurately displayed on output devices usually a printer. A PostScript interpreter inside the printer converted the vectors back into the raster dots to be printed. This allows arbitrary scaling, rotating and other transformations.

IMAGES : INTRODUCTION

The pictures that we see in our everyday life can be broadly classified into two groups:

- Images
- Graphics

Images can either be pure black and white, or grayscale having a number of grey shades, or color containing a number of color shades. Color is a sensation that light of different frequencies generates on our eyes, the higher frequencies producing the blue end and the lower frequencies producing the red end of the visible spectrum. White light is a combination of all the colors of the spectrum. To recognize and communicate color information we need to have color models. To recognize and communicate color information we need to have color models. The two most

well known color models are the **RGB model** used for colored lights like images on a monitor screen, and the **CMYK model** used for colored inks like images printed on paper. One of the most well known **device independent** color model is the **HSB Model** where the primaries are hue, saturation and brightness. The total range of colors in a color model is known as its **gamut**. The input stage deals with the issues of converting hardcopy paper images into electronic versions. This is usually done via a device called the **scanner**. While scanners are used to digitize documents, another device called the **digital camera** can convert a real world scene into a digital image. Digital camera can also contain a number of these electronic sensors which are known as **Charge-Couple Devices (CCD)** and essentially operate on the same principle as the scanner. This is the **editing** stage and involves operations like selecting, copying, scaling, rotating, trimming, changing the brightness, contrast color tones, etc. of an image to transform it as per the requirements of the application. The **output** stage involves saving the transformed image in a file format which can be displayed on the monitor screen or printed on a printer. To save the image, it is frequently compressed by a compression algorithm and the final image can be saved into a variety of **file formats**.

IMAGE TYPES:

Images that we see in our everyday lives can be categorized into various types.

1. **Hard Copy vs. Soft Copy**

The typical images that we usually come across are the pictures that have been printed on paper or some other kinds of surfaces like plastic, cloth, wood, etc. These are also called **hard copy** images because they have been printed on solid surfaces. Such images have been transformed from hard copy images or real objects into the electronic form using specialized procedures and are referred to as **soft copy** images.

2. **Continuous Tone, Half-tone and Bitone**

Photographs are also known as **continuous tone** images because they are usually composed of a large number of varying tones or shades of colors. Sometimes due to limitations of the display or printed devices, all the colors of the photograph cannot be represented adequately. In those cases a subset of the total number of colors is displayed. Such images are called **partial tone** or **half-tone** images. A third category of images is called **bitonal** images which uses only two colors, typically black and white, and do not use any shades of grey.

SEEING COLOR:

The Phenomenon of seeing color is dependent on a triad of factors: the nature of light, the interaction of light and matter, and the physiology of human vision. Light is a form of energy known as **electromagnetic radiation**. It consists of a large number of waves with varying frequencies and wavelengths. Out of the total electromagnetic spectrum a small range of waves cause sensations of light in our eyes. This is called the **visible spectrum** of waves.

The second part of the color triad is human vision. The **retina** is the light-sensitive part of the eye and its surface is composed of photoreceptors or nerve endings.

The third factor is the interaction of light with matter. Whenever light waves strike an object, part of the light energy gets **absorbed** and /or **transmitted**, while the remaining part gets **reflected** back to our eyes.

Refraction Index(RI) is the ratio of the speed of light in a vacuum. A beam of transmitted light changes direction according to the difference in refractive index and also the angle at which it strikes the transparent object. This is called **refraction**. If light is only partly transmitted by the object, the object is **translucent**.

COLOR MODELS:

Researchers have found out that most of the colors that we see around us can be derived from mixing a few elementary colors. These elementary colors are known as **primary colors**. Primary colors mixed in varying proportions produce other colors called **composite colors**. Two primary colors mixed in equal proportions produce a **secondary color**. The primary colors along with the total range of composite colors they can produce constitute a **color model**.

a) RGB Model

The RGB color model is used to describe behavior of colored lights like those emitted from a TV screen or a computer monitor. This model has three primary colors: red, green, blue, in short RGB.

Proportions of colors are determined by the beam strength. An electron beam having the maximum intensity falling on a phosphor dot creates 100% of the corresponding color. 50% of the color results from a beam having the half the peak strength. All three primary colors at full intensities combine together to produce white, i.e. their brightness values are added up. Because of this the RGB model is called an **additive model**. Lower intensity values produce shades of grey. A color present at 100% of its intensity is called **saturated**, otherwise the color is said to be **unsaturated**.

b) **CMYK Model**

The RGB model is only valid for describing behavior of colored lights. This new model is named CMYK model and is used to specify printed colors. The primary colors of this model are cyan, magenta and yellow. These colors when mixed together in equal proportions produce black, due to which the model is known as a subtractive model.

Mixing cyan and magenta in equal proportions produce blue, magenta and yellow produce red, and yellow and cyan produce green. Thus, the secondary colors of the CMYK model are the same as the primary colors of the RGB model and vice versa. These two models are thus, known as **complimentary models**.

c) **Device Dependency and Gamut**

It is to be noted that both the RGB and the CMYK models do not have universal or absolute color values. But different devices will give rise to slightly different sets of colors. For this reason both the RGB and the CMYK models are known as **device dependent** color models.

Another issue of concern here is the total range of colors supported by each color model. This is known as the **gamut** of the model.

BASIC STEPS FOR IMAGE PROCESSING:

Image processing is the name given to the entire process involved with the input, editing and output of images from a system. There are three basic steps:

a. **Input**

Image **input** is the first stage of image processing. It is concerned with getting natural images into a computer system for subsequent work. Essentially it deals with the conversion of analog images into digital forms using two devices. The first is the scanner which can convert a printed image or document into the digital form. The second is the digital camera which digitizes real-world images, similar to how a conventional camera works.

b. **Editing**

After the images have been digitized and stored as files on the hard disk of a computer, they are changed or manipulated to make them more suitable for specific requirements. This step is called editing. Before the actual editing process can begin, an important step called **color calibration** needs to be performed to ensure that the image looks consistent when viewed on multiple monitors.

c. **Output**

Image output is the last stage in image processing concerned with displaying the edited image to the user. The image can either be displayed in a stand-alone manner or as part of some application like a presentation or web-page.

SCANNER

For images, digitization involves physical devices like the **scanner** or **digital camera**. The scanner is a device used to convert analog images into the digital form. The most common type of scanner for the office environment is called the **flatbed scanner**. The traditional way of attaching a scanner to the computer is through an interface cable connected to the **parallel port** of the PC.

Construction and Working principle:

To start a scanning operation, the paper document to be scanned is placed face down on the glass panel of the scanner, and the scanner is activated using a software from the host computer. The light on getting reflected by the paper image is made to fall on a grid of electronic sensors, by an arrangement of mirrors and lenses. The electronic sensors are called **Charge Coupled Devices (CCD)** and are basically converters of the light energy into voltage pulses. After a complete scan, the image is converted from a continuous entity into a discrete form represented by a series of voltage pulses. This process is called **sampling**.

The voltage signals are temporarily stored in a buffer inside the scanner. The next step called **quantization** involves representing the voltage pulses as binary numbers and carried out by an ADC inside the scanner in conjunction with a software bundled with the scanner called the **scanning software**.

Since each number has been derived from the intensity of the incident light, these essentially represent brightness values at different points of the image and are known as **pixels**.

Scanner Types:

Scanners can be of various types each designed for specific purposes.

a. Flatbed scanners:

The flatbed scanner is the most common type in office environments and has been described above. It looks like a photocopying machine with a glass panel on which the document to be scanned is placed face down. Below the glass panel is a moving head with a source of white light usually xenon lamps.

b. Drum Scanners:

Drum Scanner is used to obtain good quality scans for professional purposes and generally provides a better performance than flatbed scanners. It consists of a cylindrical drum made out of a highly translucent plastic like material. The fluid can either be oil-based or alcohol-based. For the sensing element, drum scanners use a **Photo-Multiplier Tube (PMT)** instead of a CCD. An amplifier gain of the order of 10^8 can be achieved in multipliers containing about 14 dynode, which can provide measurable pulses from even single photons.

c. Bar-code Scanners:

A barcode scanner is designed specifically to read barcodes printed on various surfaces. A barcode is a machine-readable representation of information in a visual format. Nowadays they come in other forms like dots and concentric circles. Barcodes relieve the operator of typing strings in a computer, the encoded information is directly read by the scanner. A LASER barcode scanner is more expensive than a LED one but is capable of scanning barcodes at a distance of about 25cm. Most barcode scanners use the PS/2 port for getting connected to the computer.

d. Color Scanning

Since the CCD elements are sensitive to the brightness of the light, the pixels essentially store only the brightness information of the original image. This is also known as **luminance** (or luma) information. To include the color or **chrominance** (or chroma) information, there are three CCD elements for each pixel of image formed. White light reflected off the paper document is split into the primary color components by a glass **prism** and made to fall on the corresponding CCD sub-components.

e. Pixel Information:

To describe a color digital image, the pixels need to contain both the luma and the chroma values, i.e. the complete RGB information of each color. To represent the orange color we write: R=245 (96% of 255), G=102 (40% of 255), B=36 (14% of 255). This is called a **RGB triplet** and notation for making it more compact, e.g. given below. These values are also called **RGB attributes** of a pixel.

f. Scan quality:

The quality of a scanned image is determined mostly by its resolution and color depth. The scanner **resolution** pertains to the resolution of the CCD elements inside a scanner measured in dots per inch (dpi). Scanner resolution can be classified into two categories; the **optical resolution** refers to the actual number of sensor elements per inch on the scan head. Scanners however are often rated with resolution values higher than that of the optical resolution e.g. 5400, 7200 or 9600dpi. These resolutions are called **interpolated resolutions** and basically involve an interpolation process for generating new pixel values.

g. Scanning Software:

To scan an image, the user needs a scanning software to be installed on the computer as in (fig) given below. The software lets the user interact with the scanner and set parameters like bit depth and resolution. A typical scanning software should allow the user to do the following:

- i. Set the bit depth of the image file, which in turn determines the total number of colors.
- ii. Set the output path of the scanned image.
- iii. Set the file type of the scanned image. Most scanners nowadays support the standard file types like DMP, JPG, TIFF, etc.
- iv. Adjust the brightness and contrast parameters usually by dragging sliders.
- v. Change the size of the image by specifying a scale factor.
- vi. Adjust the color of the scanned image by manipulating the amounts of red, green and blue primaries.
- vii. Adjust the resolution value.

The 'final' button instructs the scanner to save the updated pixel values in a file whose type and location have been previously specified.

DIGITAL CAMERA:

- **Construction and working principle:**

Apart from the scanner used to digitize paper documents and film, another device used to digitize real world images is the digital camera. Unlike a scanner a digital camera is usually not attached to the computer via a cable. The camera has its own storage facility inside it usually in the form of a floppy drive, which can save the image created into a floppy disc. So instead they are **compressed** to reduce their file sizes and stored usually in the JPEG format. This is a lossy compression technique and results in slight loss in image quality.

Most of the digital cameras have an **LCD screen** at the back, which serve now important purposes: first it can be used as a viewfinder for composition and adjustment; secondly it can be used for viewing the images stored inside the camera. The recent innovation of built-in microphones provides for sound annotation, in standard WAV format. After recording, this sound can be sent to an external device for playback on headphones using an ear socket.

- **Storage and Software utility**

Digital cameras also have a **software utility** resident in a ROM chip inside it which allow the user to toggle between the CAMERA mode and PLAY mode. In the PLAY mode the user is presented with a menu structure having some of the functionalities like: displaying all the images on the floppy, selecting a particular image, deleting selected images, write-protecting the important image for deletion, setting the date and time, displaying how much of the floppy disk space is free and even allowing a floppy to be formatted in the drive.

INTERFACE STANDARDS:

Interface standards determine how data from acquisition devices like scanners and digital cameras flow to the computer in an efficient way. Refer fig.5.15. Two main interface standards exist: **TWAIN** and **ISIS**.

- i. **TWAIN:**

TWAIN is a very important standard in image acquisition, developed by Hewlett-Packard, Kodak, Aldus, Logitech and Caere which specifies how image acquisition devices such as scanners, digital cameras and other devices transfer data to software applications. It is basically an image capture API for Microsoft Windows and Apple Macintosh platforms. The standard was first released in 1992.

TWAIN is a software protocol which regulates the flow of information between software applications and imaging devices like scanners. The standard is managed by the TWAIN Working Group which is a non-profit organization with representative from leading imaging vendors. The goals of the working group included: multiple platform support, support for different types of devices like flatbed scanners, handheld scanners, image capture boards, digital cameras, etc., provide a well-defined standard that gains support and acceptance from leading hardware and software developers.

ii. Image and Scanner Interface Specification (ISIS)

The second important standard for document scanner is the Image and Scanner Interface Specification (ISIS). It was developed by Pixel Translations and they retain control over its development and licensing. ISIS has a wider set of features than TWAIN and typically uses the SCSI-2 interface while TWAIN mostly uses the USB interface. Currently ISIS compatible drivers are available for more than 250 scanner models most of them certified by Pixel Translations.

IMAGE PROCESSING SOFTWARE

Image processing software offers a wide variety of ways to manipulate and enhance images. We discuss below some of the salient features of a typical image processing software.

i) Selection Tools:

Selection Tools enables us to select a specific portion out of an image and manipulate it or copy it to another image. The selection border may be geometrical in shape like rectangular, circular, polygonal and may be irregular in shape. Selection may also be done based on color instead of shapes. fig 5.22

ii) Painting and Drawing Tools

These tools are used to paint lines, shapes, etc. or fill regions with specified colors. The colors are chosen from a color palette or specified by their RGB values. fig 5.23

iii) Color Selection Tools

These tools are used to select foreground and background colors from a color palette. They also usually allow specifying colors by their RGB values. fig 5.24

iv) Gradient Tools

Gradient Tools are used to create smooth blends of multiple colors. Gradients may be of various shapes like linear, radial, diamond-shaped, etc. fig 5.25

v) Clone Tools

Clone Tools are used to create multiple copies of specific features in an image. They are also used to select specific patterns and apply them repeatedly over an image. Fig 5.26

vi) Transformation Tools

These tools are used to transform specific portions of an image in various ways like moving, rotating, scaling, skewing, distorting, etc. fig 5.27

vii) Retouching Tools

These tools are used to change brightness/contrast of the image as well as color hues. Specific portions of the image may be desaturated, i.e. converted to grayscale. Parts of the image may also be blurred or sharpened. Fig 5.28

viii) Text Tools

These tools allow the user to include text in various styles and sizes. The text may have different colors and orientations. Fig 5.29

ix) Changing Image Characteristics

Image processing software allows images to be opened and saved in various file formats. Operations like changing image dimensions, color depth and resolution are also allowed. When the resolution of an image is modified using image processing software the total number of pixels is changed. In cases where the resolution is increased, e.g. converting from 72dpi to 300dpi, extra pixels needs to be generated by the software.

x) **Indexed color**

The term refers to a type of images usually with a limited number of color values e.g. 256. A **color lookup table** (CLUT) is used to store and index the color values of the image. Within the image file, instead of storing the actual RGB values, the index number of the row containing the specific color value is stored.

FILE FORMATS:

Images may be stored in a variety of file formats. Each file format is characterized by a specific compression type and color depth. The choice of file formats would depend on the final image quality required and the import capabilities of the authoring system. The most popular file formats are:

1) **BMP (Bitmap)**

BMP is a standard Windows compatible computer. BMP formats supports RGB, Indexed Color, Grey scale and Bitmap color modes, and does not support alpha channels.

2) **JPEG (Joint Photographers Expert Group)**

Joint Photographers Expert Group (JPEG) format is commonly used to display photographs and other continuous-tone images in hypertext markup language (HTML) documents over the World Wide Web and other online services.

3) **GIF (Graphics Interchange Format)**

Graphics Interchange Format (GIF) is the file format commonly used to display indexed color graphics and images in hypertext markup language (HTML) document over the World Wide Web and other online services.

4) **TIFF (Tagged Image File Format)**

Tagged Image File Format (TIFF) designed by Aldus Corporation and Microsoft in 1987, is used to exchange files between applications and computer platforms. TIFF is a flexible bitmap image format supported by virtually all paint, image-editing and page layout applications.

5) **PNG (Portable Network Graphics)**

Developed as a patent-free alternative to GIF, Portable Network Graphics (PNG) format is used for lossless compression and for display of images on the World Wide Web.

6) **PICT (Picture)**

PICT format is widely used among Mac OS graphics and page-layout applications as an intermediary file format for transferring images between applications. PICT format is especially effective at compression images with large areas of solid color.

7) **TGA (Targa)**

Targa (TGA) format is designed for systems using the True vision video board and is commonly supported by MS-DOS color applications. This format supports 24-bit RGB images.

8) **PSD (Photoshop Document)**

Photoshop (PSD) format is a default file format used in the Adobe Photoshop package and the only format supporting all available image modes.

IMAGE OUTPUT ON MONITOR

The image pixels are actually strings of binary numbers and therefore may be referred to as *logical pixels*. When the images are displayed on the monitor however, the logical pixels are directly mapped on to the phosphor dots of the monitor, which may be referred to as *physical pixels*.

- **Dependence on Monitor Resolution**

Let us consider an image having dimensions 1 inch by 1 inch and a resolution of 72ppi. Thus, the image is made up of 72 logical pixels horizontally and 72 logical pixels vertically. The monitor resolution in this case is *equal* to the image resolution.

Let us consider an image be rescanned at a high resolution of 144ppi. Thus, the image is made up of 144 logical pixels. The monitor resolution is however unchanged at 72dpi. The monitor resolution in this case is *less* to the image resolution.

On the other hand if the image resolution decreases to 30ppi, internally 1 inch of the image will consist of 30 logical pixels. The monitor resolution in this case is *more* than the image resolution and makes the image look smaller.

- Dependence on Monitor Size

Let us consider a 15” monitor which displays 640 pixels horizontally and 480 pixels vertically. An image with pixel dimensions of 640X480 would fill up the entire screen. If the viewing mode of the 20” Monitor is increased to 800 by 600 then the image will occupy only a portion of the screen as the available number of pixels is more than that required for displaying the image.

IMAGE OUTPUT ON PRINTER

Though there are a large variety of printers in the industry, two types are mostly used for printing multimedia content: the LASER printer and the Inkjet printer. The number of dots printed per inch of the printed page is called the **printer resolution** and expressed as dots per inch. Thus based on the final purpose the image needs to be created or scanned at the appropriate resolution.

❖ LASER Printer

The LASER printer was introduced by Hewlett-Packard in 1984, based on technology developed by Canon. It worked in a similar way to a photocopier, the difference being the light source. LASER printers quickly became popular due the high quality of their print and low running costs.

❖ Inkjet Printer

Inkjet printers, like LASER printers, employ a non-impact method meaning that there is no head or hammer striking the paper to produce the print, like typewriters or the dot-matrix printer. Ink is emitted from nozzles as they pass over a variety of possible media.

i) Thermal technology

Most inkjets use **thermal technology**, whereby heat is used to fire ink onto the paper. There are three main stages with this method. The ink emission is initiated

by heating the ink to create a bubble until the pressure forces it to burst and hit the paper. This is the method favored by Canon and Hewlett-Packard. This imposes certain limitations on the printing process in that whatever type of ink is used, it must be resistant to heat because the firing process is heat-based.

ii) Piezo-electric Technology

Epson's proprietary **piezo-electric technology** uses a piezo crystal at the back of the ink reservoir. It uses the property of certain crystals that causes them to oscillate when subjected to electrical pressure (voltage). There are several advantages to the piezo method. This allows more freedom for developing new chemical properties on ink.

iii) Inks

The ink used in inkjet technology is water-based and this poses a few problems. Oil based ink is not really a solution to the problem because it would impose a far higher maintenance cost on the hardware. Printer manufacturers are making continual progress in the development of water-resistant inks, but the print quality from inkjet printers are still weak compared to LASER printers.

UNIT –III

CHARACTERISTICS OF SOUND:

Sound waves travel at great distances in a very short time, but as the distance increases the waves tend to spread out. As the sound waves spread out, their energy simultaneously spreads through an increasingly larger area. Thus, the wave energy becomes weaker as the distance from the source is increased. Sounds may be broadly classified into two general groups. One group is NOISE, which includes sounds such as the pounding of a hammer or the slamming of a door. The other group is musical sounds, or TONES. The distinction between noise and tone is based on the regularity of the vibrations, the degree of damping, and the ability of the ear to recognize components having a musical sequence. You can best understand the physical difference between these kinds of sound by comparing the wave shape of a musical note, depicted in view A of figure 1-13, with the wave shape of noise, shown in view B. You can see by the comparison of the two wave shapes, that noise makes a very irregular and haphazard curve and a musical note makes a uniform and regular curve.

Basic Characteristics of Sound

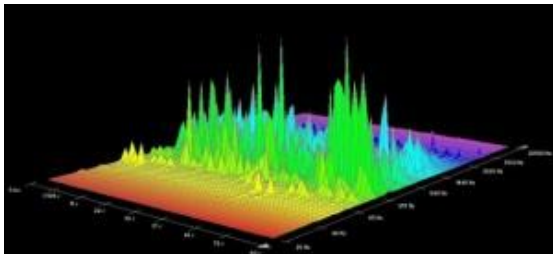

In this information Age, the quest and journey for knowledge is something we all spend a lot of time doing. Well, I don't know about you but sometimes I simply do not understand something when it is presented in only one way and so I search for other means to gain the understanding and knowledge I seek. As a result, I wander around scratching my head pondering and wondering, all the while not understanding what was being taught in that moment, until such time as new information comes along and all of a sudden the itch of wonder is replaced by knowledge and certainty.

Understanding sound and the characteristics of sound can be more easily learned in that same way. There are several concepts that are difficult to understand in [music](#) unless they are presented in more than one way too. Hopefully this article will help you to understand the basics

of sound more fully by this multi-focused approach. It is through an understanding of the characteristics that make up sound that you can more fully appreciate what you listen to, but more so, gain an understanding of some of the basic tools a composer considers and uses when creating a piece of music.

After all, music is actually and simply sound and sound has only four characteristics. When we arrange these characteristics in such a way that we find it pleasing to listen to we call that music.

The basic fundamentals of music are by their very nature a necessary tool to use in many of the future papers I will be presenting over time. The fundamental characteristics of sound consist of only; pitch, duration, quality and intensity, however, the *character* of the sequence of sounds and its arrangement is what makes music subjectively pleasing and individually enjoyed. Let's take a closer look at these four basic characteristics that comprise the foundation for everything else we will be discussing, as related to music.

Pitch* – In music notation, pitch can be seen visually by looking at the placement of a note on a musical staff. By comparing the location of where two or more notes are placed graphically, we look at their relative position to one another and we know in what direction they are related to each other, in a position of either higher or lower than another. We make a comparison of the two notes thereby easily identifying where each note is spatially on the staff by making a visual distinction. This is made possible through the use of notation software or by notating music by hand. The example below shows visually the basic concept of pitch.

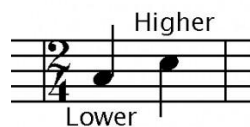

Pitch

Each sound or tone represented by the notes in the above diagram is produced or transformed from a visual only presentation by the notes as shown on the staff, to an audio and visual presentation, what we hear, when played by an instrument and what we see on the staff. Again, the notes are relative to each other, higher or lower, and we understand their relationship by making the visual comparison of one to the other. We can see pitch visually in this way and at the same time hear the sound in an analog or auditory way by playing the notes on an instrument or we can do the same thing by playing a sound clip at the same time we look at the chart below. So, before playing the notes first look at the chart and make some distinctions such as, the first note is lower than the second note on the chart. Then click on the link and listen to the sound, paying attention to and identifying the differences between the two notes being played.

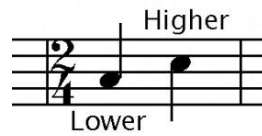

Pitch

In essence, we have two methods of determining pitch using our senses, sight and hearing. We will limit our understanding to these two senses at this time, unless you are so inclined to pull out your musical instrument and play the notes now. By doing this you can experience the notes in three senses; hearing, sight and tactile feeling. However, it is important to know that through a multiple sensory approach such as this we can learn to associate the sound of the note on the staff and in reverse hear the note and learn how to notate music. We can also learn to sing from this basis too.

Duration – Duration is also a simple concept whereby we make additional distinctions based upon the linear structure we call *time*. In music, the duration is determined by the moment the tone becomes audible until the moment the sound falls outside of our ability to hear it or it simply stops. In music notation, a half note is longer than an eighth note, a quarter note is shorter in duration than a whole note, for example.

As shown in the following chart, visually, we see notes represented by different shapes. These shapes determine the designated amount of time they are to be played. Silence is also represented in the chart by the funny little shapes in between the notes. They are called *rests* and this is also heard as silence. Note shapes partially determine the duration of the audible sound and rest shapes partially determine the duration of silence in music.

By playing the sound clip you can hear the difference between the tones in terms of duration, *longer or shorter*. We can also hear the difference in the length of the silence, again, longer or shorter. Remember, we are comparing one note to the other or one rest to the other.

After your visual review, please click on the link below the chart to hear the sound clip.



Duration

Here's another example of duration.



The notation above shows some newly presented note lengths following the eighth note in the second measure. These are sixteenth notes. Using the vibrato legato sound samples to demonstrate this aurally they sound all bunched together versus the prolonged half note for example. This is another way that composers and performers can create interesting sounds by combining different note durations.

Quality – From a church bell tower we hear the sound of the large bell ringing in the neighborhood. Assuming the bell is playing a C note and we compare a different instrument playing the same C note, a tuba for example, we can make the comparison between them listening and comparing the tonal quality or timber differences between the two instruments. This exercise will help in understanding tonal quality. Even though the *pitch* is the same for both notes they sound different, in many ways.

To further explain; below is an mp3 sample of two different instruments, one following the other. One instrument is a violin and the other is a flute, both playing the same C note or the same pitch. The difference we hear is not in duration or in pitch but in tonal quality or timbre. This aspect of music is broad and encompassing of the many different possibilities available from different instruments and from the same instrument as well. The skill and artistry of the performer also plays a significant role and highly influences the tonal quality produced by a single instrument as does the quality and character of the instrument itself.

I have used two different tones, the C and the G (that’s the one in the middle), to demonstrate the tonal characteristics by comparing the sound qualities between a flute and a violin. The last measure provides a comparison again, but this time while both instruments are simultaneously sounding.



All sounds that we hear are made up of many *overtones* in addition to a *fundamental tone*, unless the tone is a pure tone produced by a tuning fork or an electronic device. So, in music when a cellist plays a note we not only hear the note as a fundamental note but we also hear the overtones at the same time. By making sounds from different instruments and sounding them simultaneously we hear a collection of tonal qualities that is broad in scope however, again

we still primarily hear the loudest or the fundamental tone. The spectral analysis photo below demonstrates this point.

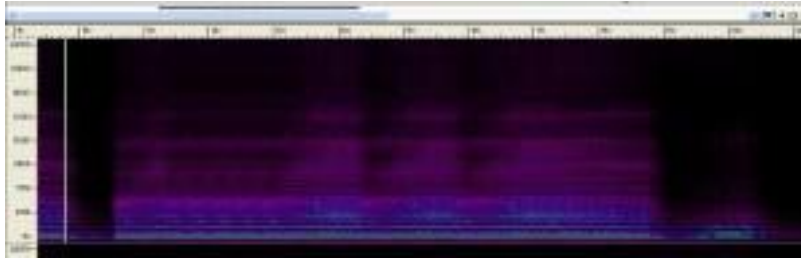

Spectral Analysis

Each peak is not simply a vertical line. It has many more nuances and sounds making up the total sound we hear. The photo shows this where in between each peak we see a lot of smaller peaks and the width of the main peaks is broad, partly contingent upon intensity and partly on overtones.

Note: Tonal quality and overtones can be further understood visually by taking a closer look at the first picture in this article. It is reproduced here for convenience.

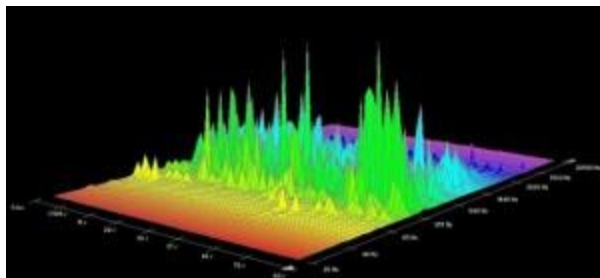

3D Sound Spectrum

The concept of and study of overtones and other sound mechanisms takes us to material and information beyond the scope of this article. Our intention here is to provide the basic understanding of the difference in tonal quality as compared to intensity, duration and pitch.

Intensity – Intensity is a measure of the loudness of the tone. Assuming that the pitch, duration and tonal quality are the same, we compare two or more tones based upon loudness or intensity. One is louder or quieter than the other. When playing a piano for instance, if we strike the keys gently we produce a quiet sound. If we strike them hard we produce a louder sound even though the pitch is the same. Here is an audio clip comparing intensity or loudness on the flute.



Intensity can also be seen when working with a wave form editor as the photo below shows. The larger the wave form the louder the sound. If you'll notice the small "wavy line" in between each of the larger wave forms in this snapshot, even though they show up on the graph, it is likely that you do not hear the sound in these locations.

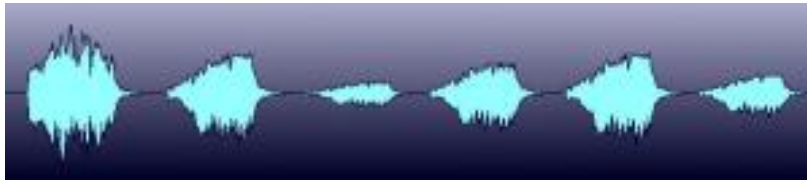

The really super cool thing about working with wave forms is that you can edit them extensively and make unique sounds out of the originally recorded instrument. That method of editing sound is only one of the ways in which digital sound can be manipulated and controlled.

The Five Elements of a Great Sounding System:

- **Clarity**

When looking at acoustic quality, Clarity is the most important element. Clarity cannot be accomplished unless you have achieved all of the other four goals. Clarity includes the ability to: understand dialogue in movies, understand musical lyrics, hear quiet details in a soundtrack or in music, and have sounds be realistic. Just about every characteristic of your sound system and room can and will affect clarity.

Having excellent clarity is the pinnacle of great sound in a system.

- **Focus**

Sit down in the "hot seat" of your home theater and play your favorite music. Now close your eyes and imagine where each instrument is located in the sound you are hearing. Every recording is designed to place instruments and sounds in a precise (or sometimes an intentionally *non*-precise) location. Focus is the ability of your system to accurately communicate those locations to your ears and brain.

Proper focus includes three aspects: the position of the sound in the soundfield (left to right and front to back), the "size" of the sound (does it sound "bigger/more pronounced" or "smaller/less pronounced" than it should), and the stability of that image (does the sound wander around as the instrument plays different notes, for example). Finally, focus allows you to

distinguish between different sounds in the recording, assuming the recording was done in a way that the sounds are actually distinguishable!

- **Envelopment**

Envelopment refers to how well your system can “surround” you with the sound. You may be surprised, but a well designed and calibrated system with only **two** speakers is still well capable of surrounding you with sound. A well done 5.1 or 7.1 system will do it even better.

Proper envelopment means a 360-degree soundfield with no holes or hotspots, accurate placement of sounds within that soundfield, and the ability to accurately reproduce the sound of the room where the recording was made.

- **Dynamic Range**

The difference between the softest sound and loudest sound a system can reproduce is its dynamic range. Most people focus on bumping up the loud side of things (with bigger amps, etc.). The reality is that the dynamic range of many home theaters is limited by the quietest sounds. The softest sounds can be buried under excessive ambient noise - whether it's fan noise, A/C noise, DVR hard drives, the kitchen refrigerator in the next room, or cars driving by outside the window.

The goal for dynamic range is to easily & effortlessly reproduce loud sounds while still ensuring that quiet sounds can be easily heard.

- **Response**

A system's response is a measurement of how equally every frequency is played by the system. The goal is a smooth response from the very low end (bass) all the way up to the highest (treble) frequencies. Examples of uneven response include:

- Boomy bass: certain bass notes knocking you out of your chair while others even a few notes higher or lower can barely be heard
- Not enough bass overall
- Instruments sounding “wrong”
- Things sounding just generally unrealistic
- A system that is tiring to listen to, causing “listener fatigue” after only a short time.

A properly tuned system will sound smooth across all frequencies, will not cause fatigue even at higher volumes, and will result in instruments and other acoustic elements sounding natural and realistic.

Microphones:

- [I. How They Work.](#)
- [II. Specifications.](#)
- [III. Pick Up Patterns](#)
- [IV. Typical Placement](#)
- [V. The Microphone Mystique](#)

I. How They Work.

A microphone is an example of a transducer, a device that changes information from one form to another. Sound information exists as patterns of air pressure; the microphone changes this information into patterns of electric current. The recording engineer is interested in the accuracy of this transformation, a concept he thinks of as fidelity.

A variety of mechanical techniques can be used in building microphones. The two most commonly encountered in recording studios are the magneto-dynamic and the variable condenser designs.

THE DYNAMIC MICROPHONE.

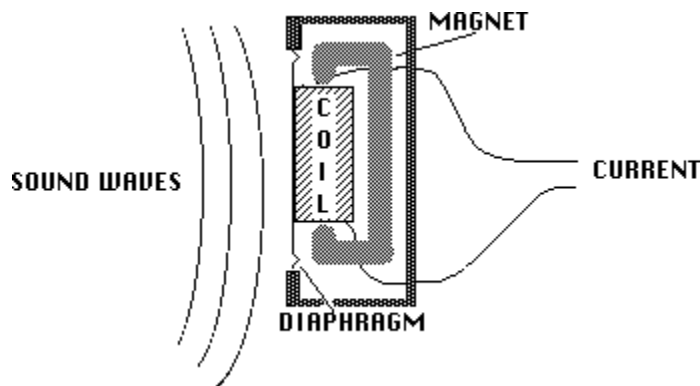

In the magneto-dynamic, commonly called dynamic, microphone, sound waves cause movement of a thin metallic diaphragm and an attached coil of wire. A magnet produces a magnetic field which surrounds the coil, and motion of the coil within this field causes current to flow. The principles are the same as those that produce electricity at the utility company, realized in a pocket-sized scale. It is important to remember that current is produced by the motion of the diaphragm, and that the amount of current is determined by the speed of that motion. This kind of microphone is known as **velocity sensitive**.

THE CONDENSER MICROPHONE.

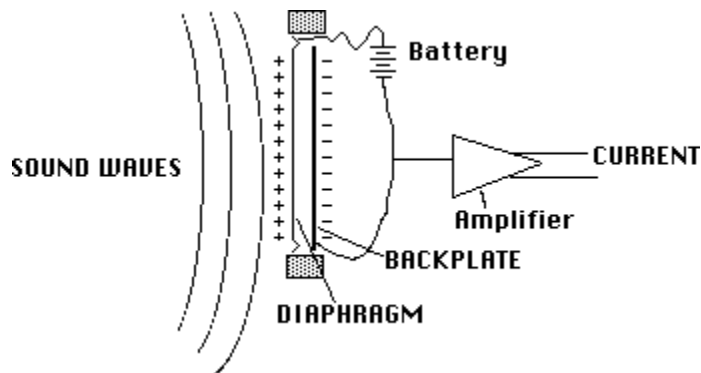

In a condenser microphone, the diaphragm is mounted close to, but not touching, a rigid backplate. (The plate may or may not have holes in it.) A battery is connected to both pieces of metal, which produces an electrical potential, or charge, between them. The amount of charge is determined by the voltage of the battery, the area of the diaphragm and backplate, and the distance between the two. This distance changes as the diaphragm moves in response to sound. When the distance changes, current flows in the wire as the battery maintains the correct charge. The amount of current is essentially proportional to the **displacement** of the diaphragm, and is so small that it must be electrically amplified before it leaves the microphone.

A common variant of this design uses a material with a permanently imprinted charge for the diaphragm. Such a material is called an **electret** and is usually a kind of plastic. (You often get a piece of plastic with a permanent charge on it when you unwrap a record. Most plastics conduct electricity when they are hot but are insulators when they cool.) Plastic is a pretty good material for making diaphragms since it can be dependably produced to fairly exact specifications. (Some popular dynamic microphones use plastic diaphragms.) The major disadvantage of electrets is that they lose their charge after a few years and cease to work.

II. Specifications

There is no inherent advantage in fidelity of one type of microphone over another. Condenser types require batteries or power from the mixing console to operate, which is occasionally a hassle, and dynamics require shielding from stray magnetic fields, which makes them a bit heavy sometimes, but very fine microphones are available of both styles. The most important factor in choosing a microphone is how it sounds in the required application. The following issues must be considered:

- **Sensitivity.**

This is a measure of how much electrical output is produced by a given sound. This is a vital specification if you are trying to record very tiny sounds, such as a turtle snapping its jaw, but should be considered in any situation. If you put an insensitive mic on a quiet instrument, such as

an acoustic guitar, you will have to increase the gain of the mixing console, adding noise to the mix. On the other hand, a very sensitive mic on vocals might overload the input electronics of the mixer or tape deck, producing distortion.

- **Overload characteristics.**

Any microphone will produce distortion when it is overdriven by loud sounds. This is caused by various factors. With a dynamic, the coil may be pulled out of the magnetic field; in a condenser, the internal amplifier might clip. Sustained overdriving or extremely loud sounds can permanently distort the diaphragm, degrading performance at ordinary sound levels. Loud sounds are encountered more often than you might think, especially if you place the mic very close to instruments. (Would you put your ear in the bell of a trumpet?) You usually get a choice between high sensitivity and high overload points, although occasionally there is a switch on the microphone for different situations.

- **Linearity, or Distortion.**

This is the feature that runs up the price of microphones. The distortion characteristics of a mic are determined mostly by the care with which the diaphragm is made and mounted. High volume production methods can turn out an adequate microphone, but the distortion performance will be a matter of luck. Many manufacturers have several model numbers for what is essentially the same device. They build a batch, and then test the mics and charge a premium price for the good ones. The really big names throw away mic capsules that don't meet their standards. (If you buy one Neumann mic, you are paying for five!)

No mic is perfectly linear; the best you can do is find one with distortion that complements the sound you are trying to record. This is one of the factors of the microphone mystique discussed later.

- **Frequency response.**

A flat frequency response has been the main goal of microphone companies for the last three or four decades. In the fifties, mics were so bad that console manufacturers began adding equalizers to each input to compensate. This effort has now paid off to the point where most professional microphones are respectably flat, at least for sounds originating in front. The major exceptions are mics with deliberate emphasis at certain frequencies that are useful for some applications. This is another part of the microphone mystique. Problems in frequency response are mostly encountered with sounds originating behind the mic, as discussed in the next section.

- **Noise.**

Microphones produce a very small amount of current, which makes sense when you consider just how light the moving parts must be to accurately follow sound waves. To be useful for recording or other electronic processes, the signal must be amplified by a factor of over a

thousand. Any electrical noise produced by the microphone will also be amplified, so even slight amounts are intolerable. Dynamic microphones are essentially noise free, but the electronic circuit built into condenser types is a potential source of trouble, and must be carefully designed and constructed of premium parts.

Noise also includes unwanted pickup of mechanical vibration through the body of the microphone. Very sensitive designs require elastic shock mountings, and mics intended to be held in the hand need to have such mountings built inside the shell.

The most common source of noise associated with microphones is the wire connecting the mic to the console or tape deck. A mic preamp is very similar to a radio receiver, so the cable must be prevented from becoming an antenna. The basic technique is to surround the wires that carry the current to and from the mic with a flexible metallic shield, which deflects most radio energy. A second technique, which is more effective for the low frequency hum induced by the power company into our environment, is to balance the line:

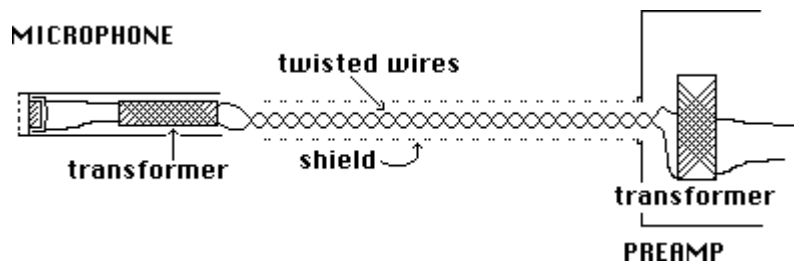

Current produced by the microphone will flow down one wire of the twisted pair, and back along the other one. Any current induced in the cable from an outside source would tend to flow the same way in both wires, and such currents cancel each other in the transformers. This system is expensive.

Microphone Levels

As I said, microphone outputs are of necessity very weak signals, generally around -60dBm. (The specification is the power produced by a sound pressure of 10 uBar) The output impedance will depend on whether the mic has a transformer balanced output. If it does not, the microphone will be labeled "high impedance" or "hi Z" and must be connected to an appropriate input. The cable used must be kept short, less than 10 feet or so, to avoid noise problems.

If a microphone has a transformer, it will be labeled low impedance, and will work best with a balanced input mic preamp. The cable can be several hundred feet long with no problem. Balanced output, low impedance microphones are expensive, and generally found in professional

applications. Balanced outputs must have three pin connectors ("Canon plugs"), but not all mics with those plugs are really balanced. Microphones with standard or miniature phone plugs are high impedance. A balanced mic can be used with a high impedance input with a suitable adapter.

You can see from the balanced connection diagram that there is a transformer at the input of the console preamp. (Or, in lieu of a transformer, a complex circuit to do the same thing.) This is the most significant difference between professional preamplifiers and the type usually found on home tape decks. You can buy transformers that are designed to add this feature to a consumer deck for about \$20 each. (Make sure you are getting a transformer and not just an adapter for the connectors.) With these accessories you can use professional quality microphones, run cables over a hundred feet with no hum, and because the transformers boost the signal somewhat, make recordings with less noise. This will not work with a few inexpensive cassette recorders, because the strong signal causes distortion. Such a deck will have other problems, so there is little point trying to make a high fidelity recording with it anyway.

III. Pick Up Patterns

Many people have the misconception that microphones only pick up sound from sources they are pointed at, much as a camera only photographs what is in front of the lens. This would be a nice feature if we could get it, but the truth is we can only approximate that action, and at the expense of other desirable qualities.

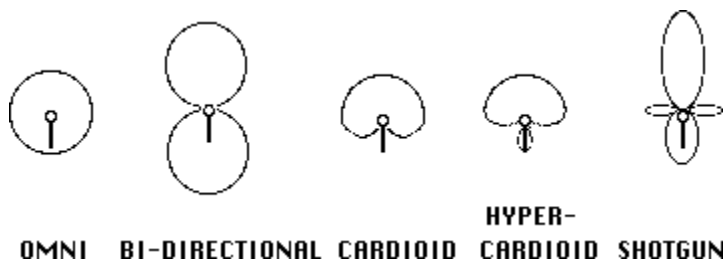

MICROPHONE PATTERNS

These are polar graphs of the output produced vs. the angle of the sound source. The output is represented by the radius of the curve at the incident angle.

Omni

The simplest mic design will pick up all sound, regardless of its point of origin, and is thus known as an omnidirectional microphone. They are very easy to use and generally have good to outstanding frequency response. To see how these patterns are produced, here's a sidebar on directional microphones.

Bi-directional

It is not very difficult to produce a pickup pattern that accepts sound striking the front or rear of the diaphragm, but does not respond to sound from the sides. This is the way any diaphragm will behave if sound can strike the front and back equally. The rejection of undesired sound is the best achievable with any design, but the fact that the mic accepts sound from both ends makes it difficult to use in many situations. Most often it is placed above an instrument. Frequency response is just as good as an omni, at least for sounds that are not too close to the microphone.

Cardioid

This pattern is popular for sound reinforcement or recording concerts where audience noise is a possible problem. The concept is great, a mic that picks up sounds it is pointed at. The reality is different. The first problem is that sounds from the back are not completely rejected, but merely reduced about 10-30 dB. This can surprise careless users. The second problem, and a severe one, is that the actual shape of the pickup pattern varies with frequency. For low frequencies, this is an omnidirectional microphone. A mic that is directional in the range of bass instruments will be fairly large and expensive. Furthermore, the frequency response for signals arriving from the back and sides will be uneven; this adds an undesired coloration to instruments at the edge of a large ensemble, or to the reverberation of the concert hall.

A third effect, which may be a problem or may be a desired feature, is that the microphone will emphasize the low frequency components of any source that is very close to the diaphragm. This is known as the "[proximity effect](#)", and many singers and radio announcers rely on it to add "chest" to a basically light voice. Close, in this context, is related to the size of the microphone, so the nice large mics with even back and side frequency response exhibit the strongest presence effect. Most cardioid mics have a built in lowcut filter switch to compensate for proximity. Missetting that switch can cause hilarious results. Bidirectional mics also exhibit this phenomenon.

Tighter Patterns

It is possible to exaggerate the directionality of cardioid type microphones, if you don't mind exaggerating some of the problems. The Hypercardioid pattern is very popular, as it gives a better overall rejection and flatter frequency response at the cost of a small back pickup lobe. This is often seen as a good compromise between the cardioid and bidirectional patterns. A "shotgun" mic carries these techniques to extremes by mounting the diaphragm in the middle of a pipe. The shotgun is extremely sensitive along the main axis, but possesses pronounced extra lobes which vary drastically with frequency. In fact, the frequency response of this mic is so bad it is usually electronically restricted to the voice range, where it is used to record dialogue for film and video.

Stereo microphones

You don't need a special microphone to record in stereo, you just need two (see below). A so called stereo microphone is really two microphones in the same case. There are two kinds: extremely expensive professional models with precision matched capsules, adjustable capsule angles, and remote switching of pickup patterns; and very cheap units (often with the capsules oriented at 180 deg.) that can be sold for high prices because they have the word stereo written on them.

IV. Typical Placement

Single microphone use

Use of a single microphone is pretty straightforward. Having chosen one with appropriate sensitivity and pattern, (and the best distortion, frequency response, and noise characteristics you can afford), you simply mount it where the sounds are. The practical range of distance between the instrument and the microphone is determined by the point where the sound overloads the microphone or console at the near end, and the point where ambient noise becomes objectionable at the far end. Between those extremes it is largely a matter of taste and experimentation.

If you place the microphone close to the instrument, and listen to the results, you will find the location of the mic affects the way the instrument sounds on the recording. The timbre may be odd, or some notes may be louder than others. That is because the various components of an instrument's sound often come from different parts of the instrument body (the highest note of a piano is nearly five feet from the lowest), and we are used to hearing an evenly blended tone. A close in microphone will respond to some locations on the instrument more than others because the difference in distance from each to the mic is proportionally large. A good rule of thumb is that the blend zone starts at a distance of about twice the length of the instrument. If you are recording several instruments, the distance between the players must be treated the same way.

If you place the microphone far away from the instrument, it will sound as if it is far away from the instrument. We judge sonic distance by the ratio of the strength of the direct sound from the instrument (which is always heard first) to the strength of the reverberation from the walls of the room. When we are physically present at a concert, we use many cues beside the sounds to keep our attention focused on the performance, and we are able to ignore any distractions there may be. When we listen to a recording, we don't have those visual clues to what is happening, and find anything extraneous that is very audible annoying. For this reason, the best seat in the house is not a good place to record a concert. On the other hand, we do need some reverberation to appreciate certain features of the music. (That is why some types of music sound best in a stone church) Close microphone placement prevents this. Some engineers prefer

to use close miking techniques to keep noise down and add artificial reverberation to the recording, others solve the problem by mounting the mic very high, away from audience noise but where adequate reverberation can be found.

Stereo

Stereo sound is an illusion of spaciousness produced by playing a recording back through two speakers. The success of this illusion is referred to as the image. A good image is one in which each instrument is a natural size, has a distinct location within the sound space, and does not move around. The main factors that establish the image are the relative strength of an instrument's sound in each speaker, and the timing of arrival of the sounds at the listener's ear. In a studio recording, the stereo image is produced artificially. Each instrument has its own microphone, and the various signals are balanced in the console as the producer desires. In a concert recording, where the point is to document reality, and where individual microphones would be awkward at best, it is most common to use two mics, one for each speaker.

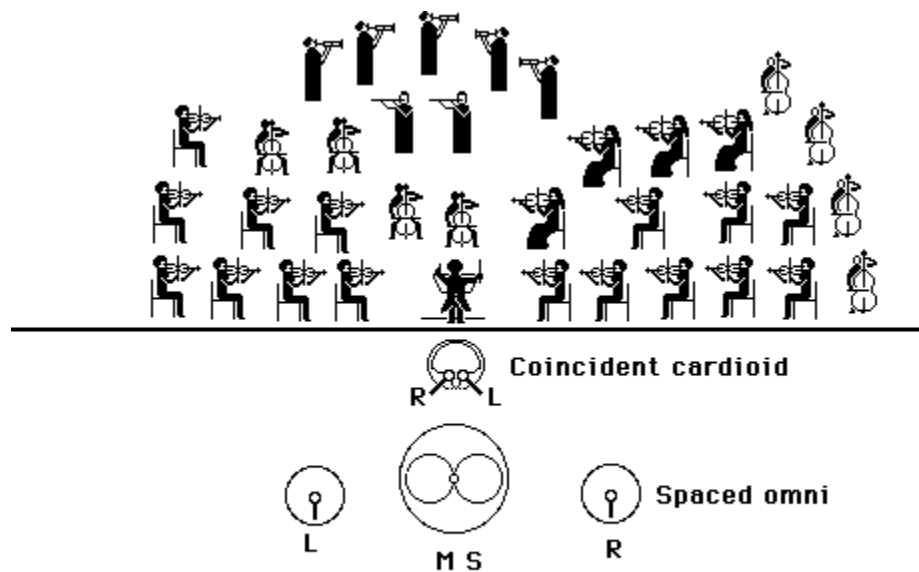

Microphone placement for stereo recording.

Spaced microphones

The simplest approach is to assume that the speakers will be eight to ten feet apart, and place two microphones eight to ten feet apart to match. Either omnis or cardioids will work. When played back, the results will be satisfactory with most speaker arrangements. (I often laugh when I attend concerts and watch people using this setup fuss endlessly with the precise placement of the mics. This technique is so forgiving that none of their efforts will make any practical difference.)

The big disadvantage of this technique is that the mics must be rather far back from the ensemble—at least as far as the distance from the leftmost performer to the rightmost. Otherwise, those

instruments closest to the microphones will be too prominent. There is usually not enough room between stage and audience to achieve this with a large ensemble, unless you can suspend the mics or have two very tall stands.

Coincident cardioids

There is another disadvantage to the spaced technique that appears if the two channels are ever mixed together into a monophonic signal. (Or broadcast over the radio, for similar reasons.) Because there is a large distance between the mics, it is quite possible that sound from a particular instrument would reach each mic at slightly different times. (Sound takes 1 millisecond to travel a foot.) This effect creates phase differences between the two channels, which results in severe frequency response problems when the signals are combined. You seldom actually lose notes from this interference, but the result is an uneven, almost shimmering sound. The various coincident techniques avoid this problem by mounting both mics in almost the same spot.

This is most often done with two cardioid microphones, one pointing slightly left, one slightly right. The microphones are often pointing toward each other, as this places the diaphragms within a couple of inches of each other, totally eliminating phase problems. No matter how they are mounted, the microphone that points to the left provides the left channel. The stereo effect comes from the fact that the instruments on the right side are on-axis for the right channel microphone and somewhat off-axis (and therefore reduced in level) for the other one. The angle between the microphones is critical, depending on the actual pickup pattern of the microphone. If the mics are too parallel, there will be little stereo effect. If the angle is too wide, instruments in the middle of the stage will sound weak, producing a hole in the middle of the image. [Incidentally, to use this technique, you must know which way the capsule actually points. There are some very fine German cardioid microphones in which the diaphragm is mounted so that the pickup is from the side, even though the case is shaped just like many popular end-addressed models. (The front of the mic in question is marked by the trademark medallion.) I have heard the results where an engineer mounted a pair of these as if the axis were at the end. You could hear one cello player and the tympani, but not much else.]

You may place the microphones fairly close to the instruments when you use this technique. The problem of balance between near and far instruments is solved by aiming the mics toward the back row of the ensemble; the front instruments are therefore off-axis and record at a lower level. You will notice that the height of the microphones becomes a critical adjustment.

M.S.

The most elegant approach to coincident miking is the M.S. or middle-side technique. This is usually done with a stereo microphone in which one element is omnidirectional, and the

other bidirectional. The bidirectional element is oriented with the axis running parallel to the stage, rejecting sound from the center. The omni element, of course, picks up everything. To understand the next part, consider what happens as instrument is moved on the stage. If the instrument is on the left half of the stage, a sound would first move the diaphragm of the bidirectional mic to the right, causing a positive voltage at the output. If the instrument is moved to center stage, the microphone will not produce any signal at all. If the instrument is moved to the right side, the sound would first move the diaphragm to the left, producing a negative voltage. You can then say that instruments on one side of the stage are 180 degrees out of phase with those on the other side, and the closer they are to the center, the weaker the signal produced.

Now the signals from the two microphones are not merely kept in two channels and played back over individual speakers. The signals are combined in a circuit that has two outputs; for the left channel output, the bidirectional output is added to the omni signal. For the right channel output, the bidirectional output is subtracted from the omni signal. This gives stereo, because an instrument on the right produces a negative signal in the bidirectional mic, which when added to the omni signal, tends to remove that instrument, but when subtracted, increases the strength of the instrument. An instrument on the left suffers the opposite fate, but instruments in the center are not affected, because their sound does not turn up in the bidirectional signal at all.

M.S. produces a very smooth and accurate image, and is entirely mono compatible. The only reason it is not used more extensively is the cost of the special microphone and decoding circuit, well over \$1,000.

Large ensembles

The above techniques work well for concert recordings in good halls with small ensembles. When recording large groups in difficult places, you will often see a combination of spaced and coincident pairs. This does produce a kind of chorusing when the signals are mixed, but it is an attractive effect and not very different from the sound of string or choral ensembles any way. When balance between large sections and soloists cannot be achieved with the basic setup, extra microphones are added to highlight the weaker instruments. A very common problem with large halls is that the reverberation from the back seems late when compared to the direct sound taken at the edge of the stage. This can be helped by placing a mic at the rear of the audience area to get the ambient sound into the recording sooner.

Studio techniques

A complete description of all of the procedures and tricks encountered in the recording studio would fill several books. These are just a few things you might see if you dropped in on the middle of a session.

Individual mics on each instrument.

This provides the engineer with the ability to adjust the balance of the instruments at the console, or, with a multitrack recorder, after the musicians have gone home. There may be eight or nine mics on the drum set alone.

Close mic placement.

The microphones will usually be placed rather close to the instruments. This is partially to avoid problems that occur when an instrument is picked up in two non-coincident mics, and partially to modify the sound of the instruments (to get a "honky-tonk" effect from a grand piano, for instance).

Acoustic fences around instruments, or instruments in separate rooms.

The interference that occurs when when an instrument is picked up by two mics that are mixed is a very serious problem. You will often see extreme measures, such as a bass drum stuffed with blankets to muffle the sound, and then electronically processed to make it sound like a drum again.

Everyone wearing headphones.

Studio musicians often play to "click tracks", which are not recorded metronomes, but someone tapping the beat with sticks and occasionally counting through tempo changes. This is done when the music must be synchronized to a film or video, but is often required when the performer cannot hear the other musicians because of the isolation measures described above.

20 or 30 takes on one song.

Recordings require a level of perfection in intonation and rhythm that is much higher than that acceptable in concert. The finished product is usually a composite of several takes.

Pop filters in front of mics.

Some microphones are very sensitive to minor gusts of wind--so sensitive in fact that they will produce a loud pop if you breath on them. To protect these mics (some of which can actually be damaged by blowing in them) engineers will often mount a nylon screen between the mic and the artist. This is not the most common reason for using pop filters though: Vocalists like to move around when they sing; in particular, they will lean into microphones. If the singer is very close to the mic, any motion will produce drastic changes in level and sound quality. (You have seen this with inexperienced entertainers using hand held mics.) Many engineers use pop filters to keep the artist at the proper distance. The performer may move slightly in relation to the screen, but that is a small proportion of the distance to the microphone.

V. The Microphone Mystique

There is an aura of mystery about microphones. To the general public, a recording engineer is something of a magician, privy to a secret arcana, and capable of supernatural feats. A few modern day engineers encourage this attitude, but it is mostly a holdover from the days when studio microphones were expensive and fragile, and most people never dealt with any electronics more complex than a table radio. There are no secrets to recording; the art is mostly a commonsense application of the principles already discussed in this paper. If there is an arcana, it is an accumulation of trivia achieved through experience with the following problems:

Matching the microphone to the instrument.

There is no wrong microphone for any instrument. Every engineer has preferences, usually based on mics with which he is familiar. Each mic has a unique sound, but the differences between good examples of any one type are pretty minor. The artist has a conception of the sound of his instrument, (which may not be accurate) and wants to hear that sound through the speakers. Frequency response and placement of the microphone will affect that sound; sometimes you need to exaggerate the features of the sound the client is looking for.

Listening the proper way.

It is easy to forget that the recording engineer is an illusionist- the result will never be confused with reality by the listener. Listeners are in fact very forgiving about some things. It is important that the engineer be able to focus his attention on the main issues and not waste time with interesting but minor technicalities. It is important that the engineer know what the main issues are. An example is the noise/distortion tradeoff. Most listeners are willing to ignore a small amount of distortion on loud passages (in fact, they expect it), but would be annoyed by the extra noise that would result if the engineer turned the recording level down to avoid it. One technique for encouraging this attention is to listen to recordings over a varitey of sound systems, good and bad.

Learning for yourself.

Many students come to me asking for a book or a course of study that will easily make them a member of this elite company. There are books, and some schools have courses in recording, but they do not supply the essential quality the professional recording engineer needs, which is experience.

A good engineer will have made hundreds of recordings using dozens of different microphones. Each session is an opportunity to make a new discovery. The engineer will make careful notes of the setup, and will listen to the results many times to build an association between the technique used and the sound achieved. Most of us do not have access to lots of professional microphones, but we could probably afford a pair of general purpose cardioids. With about \$400 worth of mics and a reliable tape deck, it is possible to learn to make excellent

recordings. The trick is to record everything that will sit still and make noise, and study the results: learn to hear when the mic is placed badly and what to do about it. When you know all you can about your mics, buy a different pair and learn those. Occasionally, you will get the opportunity to borrow mics. If possible, set them up right alongside yours and make two recordings at once. It will not be long before you will know how to make consistently excellent recordings under most conditions.

Audio amplifier:

An **audio amplifier** is an electronic amplifier that amplifies low-power audio signals (signals composed primarily of frequencies between 20 - 20 000 [Hz](#), the human range of hearing) to a level suitable for driving loudspeakers and is the final stage in a typical audio playback chain.

The preceding stages in such a chain are low power audio amplifiers which perform tasks like pre-amplification, equalization, tone control, mixing/effects, or audio sources like record players, CD players, and cassette players. Most audio amplifiers require these low-level inputs to adhere to line levels. While the input signal to an audio amplifier may measure only a few hundred microwatts, its output may be tens, hundreds, or thousands of watts.

Operational Amplifier Lecture (MP3)

Open MP3 Lecture in New Window, then minimize New Window and continue to listen and view animations below.

Inverting Amplifier Circuit

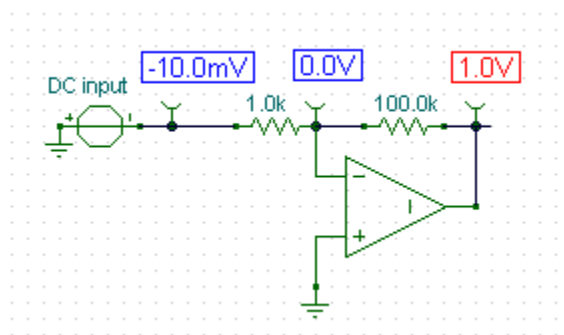

DC input varied from -10 mV to +10 mV

Non-inverting Amplifier Circuit

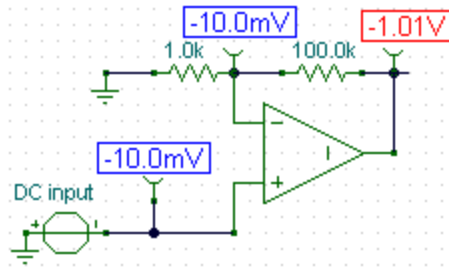

DC input varied from -10 mV to +10 mV

Dynamic Loudspeaker Principle

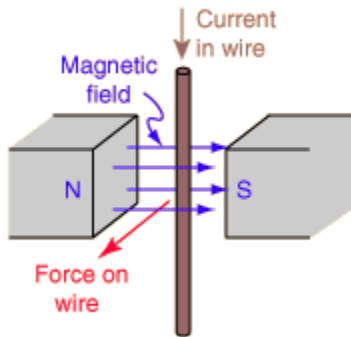

A current-carrying wire in a magnetic field experiences a magnetic force perpendicular to the wire.

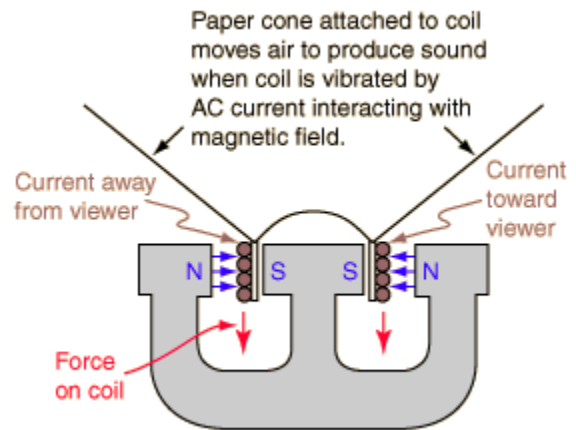

An audio signal source such as a microphone or recording produces an electrical "image" of the sound. That is, it produces an electrical signal that has the same frequency and harmonic content, and a size that reflects the relative intensity of the sound as it changes. The job of the amplifier is to take that electrical image and make it larger -- large enough in power to drive the coils of a loudspeaker. Having a "high fidelity" amplifier means that you make it larger without changing any of its properties. Any changes would be perceived as distortions of the sound since the human ear is amazingly sensitive to such changes. Once the amplifier has made the electrical image large enough, it applies it to the voice coils of the loudspeaker, making them vibrate with a pattern that follows the variations of the original signal. The voice coil is attached to and drives the cone of the loudspeaker, which in turn drives the air. This action on the air produces sound that more-or-less reproduces the sound pressure variations of the original signal.

Loudspeaker Basics

The loudspeakers are almost always the limiting element on the fidelity of a reproduced sound in either home or theater. The other stages in sound reproduction are mostly electronic, and the electronic components are highly developed. The loudspeaker involves electromechanical processes where the amplified audio signal must move a cone or other mechanical device to produce sound like the original sound wave. This process involves many difficulties, and usually is the most imperfect of the steps in sound reproduction. Choose your speakers carefully. Some basic ideas about speaker enclosures might help with perspective.



Click image for more details.

Once you have chosen a good loudspeaker from a reputable manufacturer and paid a good price for it, you might presume that you would get good sound reproduction from it. But you won't --- not without a good enclosure. The enclosure is an essential part of sound production because of the following problems with a direct radiating loudspeaker:

<p>The sound from the back of the speaker cone will tend to cancel the sound from the front, especially for low frequencies.</p>	<p>The free cone speaker is very inefficient at producing sound wavelengths longer than the diameter of the speaker.</p>
<p>Speakers have a free-cone resonant frequency which distorts the sound by responding too strongly to frequencies near resonance.</p>	<p>More power is needed in the bass range, making multiple drivers with a crossover a practical necessity for good sound.</p>

Loudspeaker system design:

Crossover:

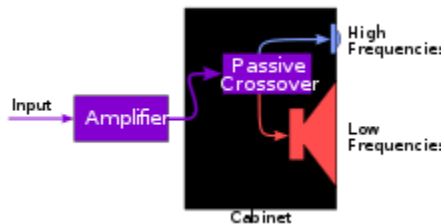

A passive crossover.

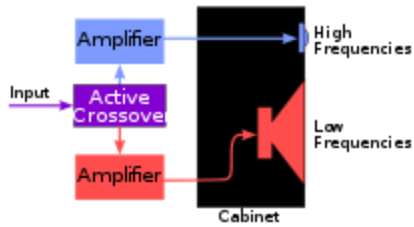

Bi-amped.

Used in multi-driver speaker systems, the crossover is a subsystem that separates the input signal into different frequency ranges suited to each driver. The drivers receive only the power in their usable frequency range (the range they were designed for), thereby reducing distortion in the drivers and interference between them.

Crossovers can be *passive* or *active*. A passive crossover is an electronic circuit that uses a combination of one or more resistors, inductors, or non-polar capacitors. These parts are formed into carefully designed networks and are most often placed between the power amplifier and the loudspeaker drivers to divide the amplifier's signal into the necessary frequency bands before being delivered to the individual drivers. Passive crossover circuits need no external power beyond the audio signal itself, but do cause overall signal loss and a significant reduction in damping factor between the voice coil and the crossover. An active crossover is an electronic filter circuit that divides the signal into individual frequency bands *before* power amplification, thus requiring at least one power amplifier for each bandpass. Passive filtering may also be used in this way before power amplification, but it is an uncommon solution, due to inflexibility compared to active filtering. Any technique that uses crossover filtering followed by amplification is commonly known as bi-amping, tri-amping, quad-amping, and so on, depending on the minimum number of amplifier channels. Some loudspeaker designs use a combination of passive and active crossover filtering, such as a passive crossover between the mid- and high-frequency drivers and an active

Crossovers, like the driver units that they feed, have power handling limits, have insertion losses (10% is often claimed), and change the load seen by the amplifier. The changes are matters of concern for many in the hi-fi world. When high output levels are required, active crossovers may be preferable. Active crossovers may be simple circuits that emulate the response of a passive network, or may be more complex, allowing extensive audio adjustments. Some active crossovers, usually digital loudspeaker management systems, may include facilities for precise alignment of phase and time between frequency bands, equalization, and dynamics (compression and limiting) control.

Some hi-fi and professional loudspeaker systems now include an active crossover circuit as part of an onboard amplifier system. These speaker designs are identifiable by their need for AC power in addition to a signal cable from a pre-amplifier. This active topology may include driver protection circuits and other features of a digital loudspeaker management system. Powered speaker systems are common in computer sound (for a single listener) and, at the other

end of the size spectrum, in modern concert sound systems, where their presence is significant and steadily increasing.

Musical Instrument Digital Interface:

MIDI (Musical Instrument Digital Interface), is an industry-standard protocol that enables electronic musical instruments (synthesizers, drum machines), computers and other electronic equipment (MIDI controllers, sound cards, samplers) to communicate and synchronize with each other. Unlike analog devices, MIDI does not transmit an audio signal — it sends event messages about pitch and intensity, control signals for parameters such as volume, vibrato and panning, cues, and clock signals to set the tempo. As an electronic protocol, it is notable for its widespread adoption throughout the music industry. MIDI protocol was defined in 1982.



Note names and MIDI note numbers.

All MIDI-compatible controllers, musical instruments, and MIDI-compatible software follow the same MIDI 1.0 specification, and thus interpret any given MIDI message the same way, and so can communicate with and understand each other. MIDI composition and arrangement takes advantage of MIDI 1.0 and General MIDI (GM) technology to allow musical data files to be shared among many different devices due to some incompatibility with various electronic instruments by using a standard, portable set of commands and parameters. Because the music is stored as instructions rather than recorded audio waveforms, the data size of the files is quite small by comparison. Individual MIDI files can be traced through their own individual

key code. This key code was established in early 1994 to combat piracy within the sharing of .mid files.

MIDI Messages:

The MIDI Message specification (or "MIDI Protocol") is probably the most important part of MIDI.

Though originally intended just for use over MIDI Cables to connect two keyboards, MIDI messages are now used inside computers and cell phones to generate music, and transported over any number of professional and consumer interfaces (USB, FireWire, etc.) to a wide variety of MIDI-equipped devices. There are different message groups for different applications, only some of which are we able to explain here.

MIDI is a music description language in digital (binary) form. It was designed for use with keyboard-based musical instruments, so the message structure is oriented to performance events, such as picking a note and then striking it, or setting typical parameters available on electronic keyboards. For example, to sound a note in MIDI you send a "Note On" message, and then assign that note a "velocity", which determines how loud it plays relative to other notes. You can also adjust the overall loudness of all the notes with a "Channel Volume" message. Other MIDI messages include selecting which instrument sounds to use, stereo panning, and more.

The first specification (1983) did not define every possible "word" that can be spoken in MIDI, nor did it define every musical instruction that might be desired in an electronic performance. So over the past 20 or more years, companies have enhanced the original MIDI specification by defining additional performance control messages, and creating companion specifications which include:

- MIDI Machine Control
- MIDI Show Control
- MIDI Time Code
- General MIDI
- Downloadable Sounds
- Scalable Polyphony MIDI

Alternate Applications MIDI Machine Control and MIDI Show Control are interesting extensions because instead of addressing musical instruments they address studio recording equipment (tape decks etc) and theatrical control (lights, smoke machines, etc.).

MIDI is also being used for control of devices where standard messages have not been defined by MMA, such as with audio mixing console automation.

Tables displaying some of the most commonly used messages for musical performance are available below and via the links in the left-hand column.. For the complete specification(s), you will need to get the most recent edition of the Complete MIDI 1.0 Detailed Specification and any supplemental documents and/or specifications that are appropriate.

Table 1 - Summary of MIDI Messages

The following table lists many of the major MIDI messages in numerical (binary) order. This table is intended as an overview of MIDI, and is by no means complete. Additional messages are listed in the printed documentation available from the MMA.

Table 1: MIDI 1.0 Specification Message Summary		
Status D7----D0	Data Byte(s) D7----D0	Description
Channel Voice Messages [nnnn = 0-15 (MIDI Channel Number 1-16)]		
1000nnnn	0kkkkkkk 0vvvvvvv	Note Off event. This message is sent when a note is released (ended). (kkkkkkk) is the key (note) number. (vvvvvvv) is the velocity.
1001nnnn	0kkkkkkk 0vvvvvvv	Note On event. This message is sent when a note is depressed (start). (kkkkkkk) is the key (note) number. (vvvvvvv) is the velocity.
1010nnnn	0kkkkkkk 0vvvvvvv	Polyphonic Key Pressure (Aftertouch). This message is most often sent by pressing down on the key after it "bottoms out". (kkkkkkk) is the key (note) number. (vvvvvvv) is the pressure value.
1011nnnn	0ccccccc 0vvvvvvv	Control Change. This message is sent when a controller value changes. Controllers include devices such as pedals and levers. Controller numbers 120-127 are reserved as "Channel Mode Messages" (below). (ccccccc) is the controller number (0-119). (vvvvvvv) is the controller value (0-127).
1100nnnn	0pppppppp	Program Change. This message sent when the patch number changes. (pppppppp) is the new program number.
1101nnnn	0vvvvvvv	Channel Pressure (After-touch). This message is most often

		sent by pressing down on the key after it "bottoms out". This message is different from polyphonic after-touch. Use this message to send the single greatest pressure value (of all the current depressed keys). (vvvvvvv) is the pressure value.
1110nnnn	0lllllll 0mmmmmmm	Pitch Wheel Change. 0mmmmmmm This message is sent to indicate a change in the pitch wheel. The pitch wheel is measured by a fourteen bit value. Center (no pitch change) is 2000H. Sensitivity is a function of the transmitter. (lllllll) are the least significant 7 bits. (mmmmmm) are the most significant 7 bits.

Channel Mode Messages (See also Control Change, above)

1011nnnn	0ccccccc 0vvvvvvv	Channel Mode Messages. This the same code as the Control Change (above), but implements Mode control and special message by using reserved controller numbers 120-127. The commands are:
		All Sound Off. When All Sound Off is received all oscillators will turn off, and their volume envelopes are set to zero as soon as possible. c = 120, v = 0: All Sound Off
		Reset All Controllers. When Reset All Controllers is received, all controller values are reset to their default values. (See specific Recommended Practices for defaults). c = 121, v = x: Value must only be zero unless otherwise allowed in a specific Recommended Practice.
		Local Control. When Local Control is Off, all devices on a given channel will respond only to data received over MIDI. Played data, etc. will be ignored. Local Control On restores the functions of the normal controllers. c = 122, v = 0: Local Control Off c = 122, v = 127: Local Control On
		All Notes Off. When an All Notes Off is received, all

oscillators will turn off.
 c = 123, v = 0: All Notes Off (See text for description of actual mode commands.)
 c = 124, v = 0: Omni Mode Off
 c = 125, v = 0: Omni Mode On
 c = 126, v = M: Mono Mode On (Poly Off) where M is the number of channels (Omni Off) or 0 (Omni On)
 c = 127, v = 0: Poly Mode On (Mono Off) (Note: These four messages also cause All Notes Off)

System Common Messages

11110000	Oiiiiiii Oddddddd --- --- Oddddddd 11110111	System Exclusive. This message makes up for all that MIDI doesn't support. (iiiiiii) is usually a seven-bit Manufacturer's I.D. code. If the synthesizer recognizes the I.D. code as its own, it will listen to the rest of the message (ddddddd). Otherwise, the message will be ignored. System Exclusive is used to send bulk dumps such as patch parameters and other non-spec data. (Note: Real-Time messages ONLY may be interleaved with a System Exclusive.) This message also is used for extensions called Universal Exclusive Messages.
11110001	Onnndddd	MIDI Time Code Quarter Frame. nnn = Message Type dddd = Values
11110010	Olllllll Ommmmmmm	Song Position Pointer. This is an internal 14 bit register that holds the number of MIDI beats (1 beat= six MIDI clocks) since the start of the song. l is the LSB, m the MSB.
11110011	Osssssss	Song Select. The Song Select specifies which sequence or song is to be played.
11110100		Undefined. (Reserved)

11110101		Undefined. (Reserved)
11110110		Tune Request. Upon receiving a Tune Request, all analog synthesizers should tune their oscillators.
11110111		End of Exclusive. Used to terminate a System Exclusive dump (see above).
System Real-Time Messages		
11111000		Timing Clock. Sent 24 times per quarter note when synchronization is required (see text).
11111001		Undefined. (Reserved)
11111010		Start. Start the current sequence playing. (This message will be followed with Timing Clocks).
11111011		Continue. Continue at the point the sequence was Stopped.
11111100		Stop. Stop the current sequence.
11111101		Undefined. (Reserved)
11111110		Active Sensing. Use of this message is optional. When initially sent, the receiver will expect to receive another Active Sensing message each 300ms (max), or it will be assume that the connection has been terminated. At termination, the receiver will turn off all voices and return to normal (non- active sensing) operation.
11111111		Reset. Reset all receivers in the system to power-up status. This should be used sparingly, preferably under manual control. In particular, it should not be sent on power-up.

MIDI Cables & Connectors:

Many different "transports" can be used for MIDI messages. The speed of the transport determines how much MIDI data can be carried, and how quickly it will be received.

Each transport has its own performance characteristics which might make some difference in specific applications, but in general the transport is the least important part of MIDI , as long as it allows you to connect all the devices you want use!

5-Pin MIDI DIN

Using a 5-pin "DIN" connector, the MIDI DIN transport was developed back in 1983, so it is slow compared to common high-speed digital transports available today, like USB, FireWire, and Ethernet. But MIDI-DIN is almost always still used on most MIDI-equipped devices because it adequately handles communication speed for one device. IF you want to connect one MIDI device to another (not a computer), MIDI cables are still the best way to go.

It used to be that connecting a MIDI device to a computer meant installing a "sound card" or "MIDI interface" in order to have a MIDI DIN connector on the computer. Because of space limitations, most such cards did not have actual 5-Pin DIN connectors on the card, but provided a special cable with 5-Pin DINs (In and Out) on one end (often connected to the "joystick port"). All such cards need "driver" software to make the MIDI connection work, but there are a few standards that companies follow, including "MPU-401" and "SoundBlaster". Even with those standards, however, making MIDI work could be a major task.

Over a number of years the components of the typical sound card and MIDI interface (including the joystick port) became standard on the motherboard of most PCs, but this did not make configuring them any easier.

Serial, Parallel, and Joystick Ports

Before USB and FireWire, personal computers were all generally equipped with serial, parallel, and (possibly) joystick ports, all of which have been used for connecting MIDI-equipped instruments (through special adapters). Though not always faster than MIDI-DIN, these connectors were already available on computers and that made them an economical alternative to add-on cards, with the added benefit that in general they already worked and did not need special configuration.

The High Speed Serial Ports such as the "mini-DIN" ports available on early Macintosh computers support communication speeds roughly 20 times faster than MIDI-DIN, making it also

possible for companies to develop and market "multiport" MIDI interfaces that allowed connecting multiple MIDI-DINs to one computer. In this manner it became possible to have the computer address many different MIDI-equipped devices at the same time. Recent multi-port MIDI interfaces use even faster USB or FireWire ports to connect to the computer.

USB and FireWire

All recent computers are equipped with either USB and/or FireWire connectors, and these are now the most common means of connecting MIDI devices to computers (using appropriate format adapters). Adapters can be as simple as a short cable with USB on one end and MIDI DIN on the other, or as complex as a 19 inch rack mountable CPU with dozens of MIDI and Audio In and Out ports. The best part is that USB and FireWire are "plug-and-play" interfaces which means they generally configure themselves. In most cases, all you need to do is plug in your USB or FireWire MIDI interface and boot up some MIDI software and off you go.

Current USB technology generally supports communication between a host (PC) and a device, so it is not possible to connect to USB devices to each other as it is with two MIDI DIN devices. (This may change sometime in the future with new versions of USB). Since communications all go through the PC, any two USB MIDI devices can use different schemes for packing up MIDI messages and sending them over USB... the USB device's driver on the host knows how that device does it, and will convert the MIDI messages from USB back to MIDI at the host. That way all USB MIDI devices can talk to each other (through the host) without needing to follow one specification for how they send MIDI data over USB.

Most FireWire MIDI devices also connect directly to a PC with a host device driver and so can talk to other FireWire MIDI devices even if they use a proprietary method for formatting their MIDI data. But FireWire supports "peer-to-peer" connections, so MMA has produced a specification for [MIDI over IEEE-1394](#) (FireWire), which is available for download on this site (and incorporated in IEC-61883 part 5).

Ethernet

If you are connecting a number of MIDI instruments to one or more computers, using Ethernet seems like a great solution. In the MIDI industry there is not yet agreement on the market desire for MIDI over Ethernet, nor on the net value of the benefits vs. challenges of using Ethernet, and so there is currently no MMA standard for MIDI over Ethernet.

However, other Standard Setting Organizations have specifications for MIDI Over Ethernet, and we think it appropriate that people know about those solutions. There are also proprietary solutions for MIDI Over Ethernet, but because they are not open standards they are not appropriate for discussion by MMA.

- ***IETF RTP-MIDI***

The IETF RTP Payload Format for MIDI solution has received extensive modification in response to comments by MMA-members, and is also the foundation of Apple's own MIDI Over Ethernet solution. Though neither solution has been officially adopted or endorsed in any way by MMA, both technologies have stood up to MMA member scrutiny and so are likely to appear (in one manner or another) in future MIDI hardware and/or software products.

- **IEEE Ethernet AVB**

For the past several years, the IEEE has been developing protocols for low-latency audio and video transport over Ethernet with high quality of service. These protocols are known as Audio/Video Bridging, or AVB, and are part of the larger IEEE 802.1 Working Group, which develops networking standards that enable interoperability of such ubiquitous devices as Ethernet switches. The AVB protocols provide precision time synchronization and stream bandwidth reservation at the network level.

The AVB protocols do not provide a standard means for interoperable communication of content such as a live video stream. Utilizing the 802.1 AVB protocols, the IEEE P1722 AVB Transport Protocol (AVBTP) draft standard provides the necessary content encapsulation in an evolutionary manner by adopting the existing IEEE 1394 (Firewire) audio and video streaming mechanisms already in use by millions of devices. However, AVBTP is not limited to bridging IEEE 1394 content, as it provides extensibility to encapsulate new and different media formats.

The MMA collaborated with the IEEE P1722 working group to enable transport of MIDI and any future content format defined by the MMA over IEEE P1722 networks. The P1722 standard defines MIDI 1.0 content within this protocol by referencing an MMA-authored document. The MMA has not yet published that document, but plans to do so in the near future.

Basic MIDI Connections:

Let's first take a look at what you need to get your MIDI (Recording) system setup:

Hardware:

- Computer - either PC or laptop.
- MIDI keyboard or USB keyboard with or without sounds.
- Soundcard either fitted inside your computer or external soundcard.
- USB or MIDI cable(s).

Software

- Install drivers for soundcard (better to download latest version from manufacturer). **SEARCH TIP:** Go to Google and search "Model number of card + drivers download". i.e. If your soundcard is called "SoundcardXYZ" then type "SoundcardXYZ drivers download" (without the quotes) into

Google. There is a high probability that Google will give you the exact page you need for the latest drivers.

- Install latest drivers for keyboard (if needed) - more common for USB keyboards.
- Install MIDI Sequencing package - Cubase LE

Brief Connection Concept

- IMPORTANT MIDI CONNECTIONS - Always connect MIDI OUT from one device to MIDI IN on the other or vice-versa.
- If you have a computer a keyboard or any external sound modules then connect as shown below:

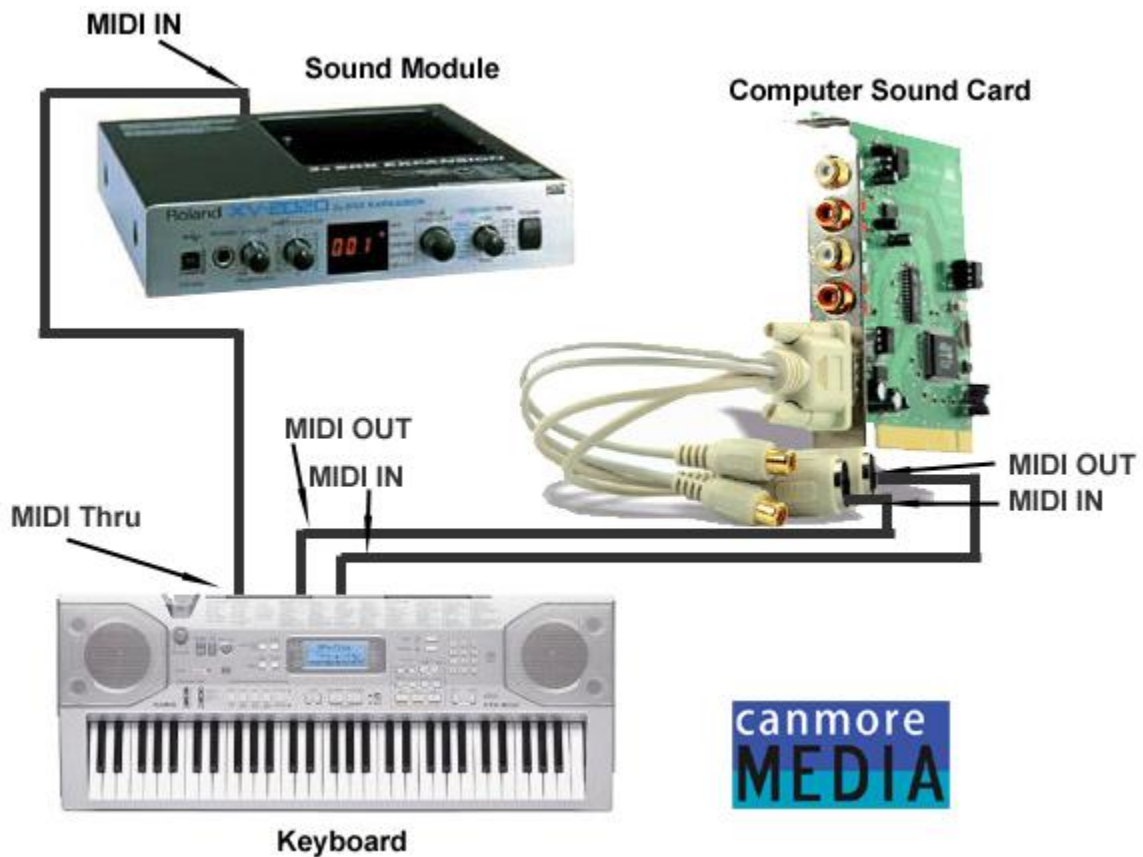

- If you have an additional module to add to the setup above then simply connect a MIDI OUT from the sound module to the additional module (MIDI IN).
- Having a large number of MIDI chain connections is not advisable and not really practical when it comes to controlling your MIDI channels from within the sequencing software - The system above only allows you 16 channels of sounds playing simultaneously. Of course, this depends on the equipment, but let's just assume that the keyboard and module are multi-timbral and can play 16 channels at the same time. Because of the setup above you are limited.

MIDI Thru Box - A MIDI thru box is advisable on bigger systems to allow more than 16 channels be played back simultaneously - the MIDI output of each MIDI port on the Thru box is controlled from within the sequencing package. For example, let's say we are using Cubase. Track 1 is playing MIDI channel 1, Track 2 plays MIDI channel 2 etc. etc. The

MIDI output of MIDI channel 1 is routed to the MIDI Thru Box - Port 1, The MIDI output of MIDI channel 2 is routed to the MIDI Port 2. So, for 4 MIDI ports connected to 4 different devices you can have 64 MIDI channels!

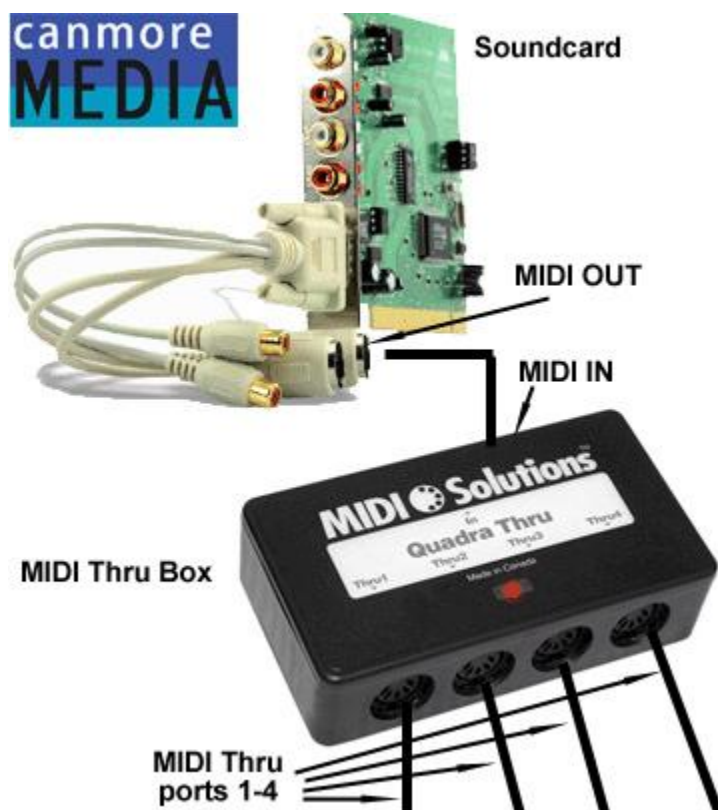

MIDI Thru Box Output - 16 Channels from each port



MIDI Thru Port 1	MIDI Thru Port 2	MIDI Thru Port 3	MIDI Thru Port 4
MIDI Channel 01	MIDI Channel 01	MIDI Channel 01	MIDI Channel 01
MIDI Channel 02	MIDI Channel 02	MIDI Channel 02	MIDI Channel 02
MIDI Channel 03	MIDI Channel 03	MIDI Channel 03	MIDI Channel 03
MIDI Channel 04	MIDI Channel 04	MIDI Channel 04	MIDI Channel 04
MIDI Channel 05	MIDI Channel 05	MIDI Channel 05	MIDI Channel 05
MIDI Channel 06	MIDI Channel 06	MIDI Channel 06	MIDI Channel 06
MIDI Channel 07	MIDI Channel 07	MIDI Channel 07	MIDI Channel 07
MIDI Channel 08	MIDI Channel 08	MIDI Channel 08	MIDI Channel 08
MIDI Channel 09	MIDI Channel 09	MIDI Channel 09	MIDI Channel 09
MIDI Channel 10	MIDI Channel 10	MIDI Channel 10	MIDI Channel 10
MIDI Channel 11	MIDI Channel 11	MIDI Channel 11	MIDI Channel 11
MIDI Channel 12	MIDI Channel 12	MIDI Channel 12	MIDI Channel 12
MIDI Channel 13	MIDI Channel 13	MIDI Channel 13	MIDI Channel 13
MIDI Channel 14	MIDI Channel 14	MIDI Channel 14	MIDI Channel 14
MIDI Channel 15	MIDI Channel 15	MIDI Channel 15	MIDI Channel 15
MIDI Channel 16	MIDI Channel 16	MIDI Channel 16	MIDI Channel 16

Connect

- Assuming you have installed your software and hardware correctly you are literally steps away from completing your MIDI setup!
- If you have a USB Keyboard then connect it to your USB port on your computer. Load up your MIDI sequencing software and see if you can see the MIDI input from your sequencing software. Cubase LE is great for this and will show if your connection has been established by displaying a light trigger when ever you play your keyboard.
- If you have a MIDI keyboard then connect the MIDI cable from your MIDI Out on the keyboard to MIDI In on your soundcard. As above, if you have Cubase installed then it will display a connection if you depress a key on the keyboard.

Want to play the sounds on your keyboard?

- If you want to playback the sounds of your keyboard then you have to connect the MIDI Out from your soundcard to the MIDI In of your keyboard.
- So, when recording, you play out the notes from your keyboard into your computer (sequencer) then after you've finished recording the computer will playback MIDI recorded information back from the MIDI Out port of the computer to the MIDI In of your keyboard. It's quite simple!
- Multitrack MIDI recording - Simple! Same as above, keep recording and pre-recorded tracks will playback when you are recording additional tracks.

This is a generic description of your MIDI setup and you may have to customise it slightly for your own setup since very few MIDI setups are the same it's almost impossible to give a direct answer to this popular topic.

Sound card:

A sound card (also known as an audio card) is a computer expansion card that facilitates the input and output of audio signals to and from a computer under control of computer programs. Typical uses of sound cards include providing the audio component for multimedia applications such as music composition, editing video or audio, presentation, education, and entertainment (games). Many computers have sound capabilities built in, while others require additional expansion cards to provide for audio capability.



Sound cards usually feature a digital-to-analog converter (DAC), which converts recorded or generated digital data into an analog format. The output signal is connected to an amplifier, headphones, or external device using standard interconnects, such as a TRS connector or an RCA connector. If the number and size of connectors is too large for the space on the backplate the connectors will be off-board, typically using a breakout box, or an auxiliary backplate. More advanced cards usually include more than one sound chip to provide for higher data rates and multiple simultaneous functionality, eg between digital sound production and synthesized sounds (usually for real-time generation of music and sound effects using minimal data and CPU time). Digital sound reproduction is usually done with multi-channel DACs, which are capable of multiple digital samples simultaneously at different pitches and volumes, or optionally applying real-time effects like filtering or distortion. Multi-channel digital sound playback can also be used for music synthesis when used with a compliance, and even multiple-channel emulation. This approach has become common as manufacturers seek to simplify the design and the cost of sound cards.

Most sound cards have a **line in** connector for signal from a cassette tape recorder or similar sound source. The sound card digitizes this signal and stores it (under control of appropriate matching computer software) on the computer's hard disk for storage, editing, or further processing. Another common external connector is the **microphone** connector, for use by a microphone or other low level input device. Input through a microphone jack can then be used by speech recognition software or for Voice over IP applications.

Audio file format:

An **audio file format** is a file format for storing audio data on a computer system. It can be a raw bitstream, but it is usually a container format or an audio data format with defined storage layer.

The general approach towards storing digital audio is to sample the audio voltage which, on playback, would correspond to a certain level of signal in an individual channel with a certain *resolution*—the number of bits per sample—in regular intervals (forming the sample rate). This data can then be stored uncompressed, or compressed to reduce the file size

Types of formats:

It is important to distinguish between a file format and a CODEC. A codec performs the encoding and decoding of the raw audio data while the data itself is stored in a file with a specific audio file format. Most of the publicly documented audio file formats can be created with one of two or more encoders or codecs. Although most audio file formats support only one type of audio data (created with an audio coder), a multimedia container format (as MKV or AVI) may support multiple types of audio and video data.

There are three major groups of audio file formats:

- Uncompressed audio formats, such as WAV, AIFF, AU or raw header-less PCM;
- formats with lossless compression, such as FLAC, Monkey's Audio (filename extension APE), WavPack (filename extension WV), Shorten, TTA, ATRAC Advanced Lossless, Apple Lossless, MPEG-4 SLS, MPEG-4 ALS, MPEG-4 DST, Windows Media Audio Lossless (WMA Lossless).
- formats with lossy compression, such as MP3, Vorbis, Musepack, AAC, ATRAC and lossy Windows Media Audio (WMA).

Uncompressed audio formats

There is one major uncompressed audio format, PCM which is usually stored as a .wav on Windows or as .aiff on Mac OS. WAV and AIFF are flexible file formats designed to store more or less any combination of sampling rates or bitrates. This makes them suitable file formats for storing and archiving an original recording. There is another uncompressed audio format which is .cda (Audio CD Track) .cda is from a music CD and is 0% compressed.

The AIFF format is based on the IFF format. The WAV format is based on the RIFF file format, which is similar to the IFF format.

BWF (Broadcast Wave Format) is a standard audio format created by the European Broadcasting Union as a successor to WAV. BWF allows metadata to be stored in the file. See *European Broadcasting Union: Specification of the Broadcast Wave Format* (EBU Technical document 3285, July 1997). This is the primary recording format used in many professional audio workstations in the television and film industry. BWF files include a standardized Timestamp reference which allows for easy synchronization with a separate picture element. Stand-alone,

file based, multi-track recorders from Sound Devices, Zaxcom, HHB USA, Fostex, and Aaton all use BWF as their preferred format.

Lossless compressed audio formats

A lossless compressed format requires much more processing time than an uncompressed format but is more efficient in space usage.

Uncompressed audio formats encode both sound and silence with the same number of bits per unit of time. Encoding an uncompressed minute of absolute silence produces a file of the same size as encoding an uncompressed minute of symphonic orchestra music. In a lossless compressed format, however, the music would occupy a marginally smaller file and the silence take up almost no space at all.

Lossless compression formats (such as the most widespread FLAC, WavPack, Monkey's Audio, ALAC/Apple Lossless) provide a compression ratio of about 2:1. Development in lossless compression formats aims to reduce processing time while maintaining a good compression ratio.

Free and open file formats

- **wav** – standard audio file container format used mainly in Windows PCs. Commonly used for storing uncompressed (PCM), CD-quality sound files, which means that they can be large in size—around 10 MB per minute. Wave files can also contain data encoded with a variety of (lossy) codecs to reduce the file size (for example the GSM or mp3 codecs). Wav files use a RIFF structure.
- **ogg** – a free, open source container format supporting a variety of codecs, the most popular of which is the audio codec Vorbis. Vorbis offers compression similar to MP3 but is less popular.
- **mpc** - Musepack or MPC (formerly known as MPEGplus, MPEG+ or MP+) is an open source lossy audio codec, specifically optimized for transparent compression of stereo audio at bitrates of 160–180 kbit/s.
- **flac** – Free Lossless Audio Codec, a lossless compression codec.
- **aiff** – standard audio file format used by Apple. It could be considered the Apple equivalent of wav.
- **raw** – a raw file can contain audio in any codec but is usually used with PCM audio data. It is rarely used except for technical tests.
- **au** – the standard audio file format used by Sun, Unix and Java. The audio in au files can be PCM or compressed with the μ -law, a-law or G729 codecs.

Open file formats

- **gsm** – designed for telephony use in Europe, gsm is a very practical format for telephone quality voice. It makes a good compromise between file size and quality. Note that wav files can also be encoded with the gsm codec.
- **dct** – A variable codec format designed for dictation. It has dictation header information and can be encrypted (often required by medical confidentiality laws).

- [vox](#) – the vox format most commonly uses the Dialogic ADPCM (Adaptive Differential Pulse Code Modulation) codec. Similar to other ADPCM formats, it compresses to 4-bits. Vox format files are similar to wave files except that the vox files contain no information about the file itself so the codec sample rate and number of channels must first be specified in order to play a vox file.
- [mmf](#) - a Samsung audio format that is used in ringtones.

Proprietary formats

- [mp3](#) – MPEG Layer-3 format is the most popular format for downloading and storing music. By eliminating portions of the audio file that are less audible, mp3 files are compressed to roughly one-tenth the size of an equivalent PCM file sacrificing quality.
- [aac](#) – the Advanced Audio Coding format is based on the MPEG2 and MPEG4 standards. aac files are usually ADTS or ADIF containers.
- [mp4/m4a](#) – MPEG-4 audio most often AAC but sometimes MP2/MP3, MPEG-4 SLS, CELP, HVXC and other audio object types defined in MPEG-4 Audio
- [wma](#) – the popular Windows Media Audio format owned by Microsoft. Designed with Digital Rights Management (DRM) abilities for copy protection.
- [atrac](#) (.wav) – the older style Sony ATRAC format. It always has a .wav file extension. To open these files simply install the ATRAC3 drivers.
- [ra & rm](#) – a Real Audio format designed for streaming audio over the Internet. The .ra format allows files to be stored in a self-contained fashion on a computer, with all of the audio data contained inside the file itself.
- [ram](#) – a text file that contains a link to the Internet address where the Real Audio file is stored. The .ram file contains no audio data itself.
- [dss](#) – Digital Speech Standard files are an Olympus proprietary format. It is a fairly old and poor codec. Gsm or mp3 are generally preferred where the recorder allows. It allows additional data to be held in the file header.
- [msv](#) – a Sony proprietary format for Memory Stick compressed voice files.
- [dvf](#) – a Sony proprietary format for compressed voice files; commonly used by Sony dictation recorders.
- [ivs](#) – A proprietary version with Digital Rights Management developed by 3D Solar UK Ltd for use in music downloaded from their Tronme Music Store and interactive music and video player.
- [m4p](#) – A proprietary version of AAC in MP4 with Digital Rights Management developed by Apple for use in music downloaded from their iTunes Music Store.
- [iklax](#) – An iKlax Media proprietary format, the iKlax format is a multi-track digital audio format allowing various actions on musical data, for instance on mixing and volumes arrangements.
- [mxp4](#) – a Musinaut proprietary format allowing play of different versions (or skins) of the same song. It allows various interactivity scenarios between the artist and the end user.
- [3gp](#) - multimedia container format can contain proprietary formats as [AMR](#), [AMR-WB](#) or [AMR-WB+](#), but also some open formats
- [amr](#) - AMR-NB audio, used primarily for speech
- [awb](#) - AMR-WB audio, used primarily for speech

Codec:

A **codec** is a device or computer program capable of encoding and/or decoding a [digital](#) data stream or signal. The word *codec* is a portmanteau of 'compressor-decompressor' or, more

commonly, '**coder-decoder**'. A *codec* (the *program*) should not be confused with a coding or compression *format* or *standard* – a format is a document (the standard), a way of storing data, while a codec is a program (an *implementation*) which can read or write such files. In practice "codec" is sometimes used loosely to refer to formats, however.

A codec encodes a data stream or signal for transmission, storage or encryption, or decodes it for playback or editing. Codecs are used in videoconferencing, streaming media and video editing applications. A video camera's analog-to-digital converter (ADC) converts its analog signals into digital signals, which are then passed through a video compressor for digital transmission or storage. A receiving device then runs the signal through a video decompressor, then a digital-to-analog converter (DAC) for analog display. The term *codec* is also used as a generic name for a video conferencing unit.

Media codecs:

Codecs are often designed to emphasize certain aspects of the media, or their use, to be encoded. For example, a digital video (using a DV codec) of a sports event needs to encode motion well but not necessarily exact colors, while a video of an art exhibit needs to perform well encoding color and surface texture.

Audio codecs for cell phones need to have very low latency between source encoding and playback; while audio codecs for recording or broadcast can use high-latency audio compression techniques to achieve higher fidelity at a lower bit-rate.

There are thousands of audio and video codecs ranging in cost from free to hundreds of dollars or more. This variety of codecs can create compatibility and obsolescence issues. By contrast, raw uncompressed PCM audio (44.1 kHz, 16 bit stereo, as represented on an audio CD or in a .wav or .aiff file) is a standard across multiple platforms.

Many multimedia data streams contain both audio and video, and often some metadata that permit synchronization of audio and video. Each of these three streams may be handled by different programs, processes, or hardware; but for the multimedia data streams to be useful in stored or transmitted form, they must be encapsulated together in a container format.

Lower bit rate codecs allow more users, but they also have more distortion. Beyond the initial increase in distortion, lower bit rate codecs also achieve their lower bit rates by using more complex algorithms that make certain assumptions, such as those about the media and the packet loss rate. Other codecs may not make those same assumptions. When a user with a low bit-rate codec talks to a user with another codec, additional distortion is introduced by each transcoding.

The notion of AVI being a codec is incorrect as AVI is a container format, which many codecs might use (although not to ISO standard). There are also other well-known containers such as Ogg, ASF, QuickTime, RealMedia, Matroska, DivX Media Format and containers defined as ISO standards, such as MPEG transport stream, MPEG program stream, MP4 and ISO base media file format.

Audio player (software):

An **audio player** is a kind of media player for playing back digital audio, including optical discs such as CDs, SACDs, DVD-Audio, HDCD, audio files and streaming audio.

In addition to VCR-like functions like playing, pausing, stopping, rewinding, and forwarding, some common functions include playlisting, tagging format support, and equalizer.

Many of the audio players also support simple playback of digital videos in which we can also run movies.

Digital audio player:

Digital audio player, **shortened to DAP, MP3 player or, rarely, as an OGG player, is a consumer electronic device that stores, organizes and plays digital audio files. In contrast, analog audio players play music from cassette tapes, or records. Portable devices that also play video and text are referred to as portable media players.**

Sound recording and reproduction:

Sound recording and reproduction is an electrical or mechanical inscription and re-creation of sound waves, such as spoken voice, singing, instrumental music, or sound effects. The two main classes of sound recording technology are analog recording and digital recording. Acoustic analog recording is achieved by a small microphone diaphragm that can detect changes in atmospheric pressure (acoustic sound waves) and record them as a graphic representation of the sound waves on a medium such as a phonograph (in which a stylus senses grooves on a record). In magnetic tape recording, the sound waves vibrate the microphone diaphragm and are converted into a varying electric current, which is then converted to a varying magnetic field by an electromagnet, which makes a representation of the sound as magnetized areas on a plastic tape with a magnetic coating on it. Analog sound reproduction is the reverse process, with a bigger loudspeaker diaphragm causing changes to atmospheric pressure to form acoustic sound waves. Electronically generated sound waves may also be recorded directly from devices such as an electric guitar pickup or a synthesizer, without the use of acoustics in the recording process other than the need for musicians to hear how well they are playing during recording sessions.

Digital recording and reproduction converts the analog sound signal picked up by the microphone to a digital form by a process of digitization, allowing it to be stored and transmitted by a wider variety of media. Digital recording stores audio as a series of binary numbers representing samples of the amplitude of the audio signal at equal time intervals, at a sample rate so fast that the human ear perceives the result as continuous sound. Digital recordings are considered higher quality than analog recordings not necessarily because they have higher fidelity (wider frequency response or dynamic range), but because the digital format can prevent much loss of quality found in analog recording due to noise and electromagnetic interference in playback, and mechanical deterioration or damage to the storage medium. A digital audio signal

must be reconverted to analog form during playback before it is applied to a loudspeaker or earphones.

Electrical recording:

Sound recording began as a mechanical process and remained so until the early 1920s (with the exception of the 1899 Telegraphone) when a string of groundbreaking inventions in the field of electronics revolutionised sound recording and the young recording industry. These included sound transducers such as microphones and loudspeakers and various electronic devices such as the mixing desk, designed for the amplification and modification of electrical sound signals.

After the Edison phonograph itself, arguably the most significant advances in sound recording, were the electronic systems invented by two American scientists between 1900 and 1924. In 1906 Lee De Forest invented the "Audion" triode vacuum-tube, electronic valve, which could greatly amplify weak electrical signals, (one early use was to amplify long distance telephone in 1915) which became the basis of all subsequent electrical sound systems until the invention of the transistor. The valve was quickly followed by the invention of the Regenerative circuit, Super-Regenerative circuit and the Superheterodyne receiver circuit, all of which were invented and patented by the young electronics genius Edwin Armstrong between 1914 and 1922. Armstrong's inventions made higher fidelity electrical sound recording and reproduction a practical reality, facilitating the development of the electronic amplifier and many other devices; after 1925 these systems had become standard in the recording and radio industry.

While Armstrong published studies about the fundamental operation of the triode vacuum tube before World War I, inventors like Orlando R. Marsh and his Marsh Laboratories, as well as scientists at Bell Telephone Laboratories, achieved their own understanding about the triode and were utilizing the Audion as a repeater in weak telephone circuits. By 1925 it was possible to place a long distance telephone call with these repeaters between New York and San Francisco in 20 minutes, both parties being clearly heard. With this technical prowess, Joseph P. Maxfield and Henry C. Harrison from Bell Telephone Laboratories were skilled in using mechanical analogs of electrical circuits and applied these principles to sound recording and reproduction. They were ready to demonstrate their results by 1924 using the Wente condenser microphone and the vacuum tube amplifier to drive the "rubber line" wax recorder to cut a master audio disc.

Meanwhile, radio continued to develop. Armstrong's groundbreaking inventions (including FM radio) also made possible the broadcasting of long-range, high-quality radio transmissions of voice and music. The importance of Armstrong's Superheterodyne circuit cannot be over-estimated — it is the central component of almost all analog amplification and both analog and digital radio-frequency transmitter and receiver devices to this day

Beginning during World War One, experiments were undertaken in the United States and Great Britain to reproduce among other things, the sound of a Submarine (u-boat) for training purposes. The acoustical recordings of that time proved entirely unable to reproduce the sounds, and other methods were actively sought. Radio had developed independently to this point, and

now Bell Laboratories sought a marriage of the two disparate technologies, greater than the two separately. The first experiments were not very promising, but by 1920 greater sound fidelity was achieved using the electrical system than had ever been realized acoustically. One early recording made without fanfare or announcement was the dedication of the Tomb of the Unknown Soldier at Arlington Cemetery.

By early 1924 such dramatic progress had been made, that Bell Labs arranged a demonstration for the leading recording companies, the Victor Talking Machine Company, and the Columbia Phonograph Co. (Edison was left out due to their decreasing market share and a stubborn Thomas Edison). Columbia, always in financial straits, could not afford it, and Victor, essentially leaderless since the mental collapse of founder Eldridge Johnson, left the demonstration without comment. English Columbia, by then a separate company, got hold of a test pressing made by Pathé from these sessions, and realized the immediate and urgent need to have the new system. Bell was only offering its method to United States companies, and to circumvent this, Managing Director Louis Sterling of English Columbia, bought his once parent company, and signed up for electrical recording. Although they were contemplating a deal, Victor Talking Machine was apprised of the new Columbia deal, so they too quickly signed. Columbia made its first released electrical recordings on February 25, 1925, with Victor following a few weeks later. The two then agreed privately to "be quiet" until November 1925, by which time enough electrical repertory would be available.

Other recording formats

In the 1920s, the early talkies featured the new sound-on-film technology which used photoelectric cells to record and reproduce sound signals that were optically recorded directly onto the movie film. The introduction of talking movies, spearheaded by *The Jazz Singer* in 1927 (though it used a sound on disk technique, not a photoelectric one), saw the rapid demise of live cinema musicians and orchestras. They were replaced with pre-recorded soundtracks, causing the loss of many jobs. The American Federation of Musicians took out ads in newspapers, protesting the replacement of real musicians with mechanical playing devices, especially in theatres.

This period also saw several other historic developments including the introduction of the first practical magnetic sound recording system, the magnetic wire recorder, which was based on the work of Danish inventor Valdemar Poulsen. Magnetic wire recorders were effective, but the sound quality was poor, so between the wars they were primarily used for voice recording and marketed as business dictating machines. In the 1930s radio pioneer Guglielmo Marconi developed a system of magnetic sound recording using steel tape. This was the same material used to make razor blades, and not surprisingly the fearsome Marconi-Stillé recorders were considered so dangerous that technicians had to operate them from another room for safety. Because of the high recording speeds required, they used enormous reels about one metre in diameter, and the thin tape frequently broke, sending jagged lengths of razor steel flying around the studio.

Audio and Multimedia

Multimedia content on the Web, by its definition - including or involving the use of several media - would seem to be inherently accessible or easily made accessible.

However, if the information is audio, such as a RealAudio feed from a news conference or the proceedings in a courtroom, a person who is deaf or hard of hearing cannot access that content unless provision is made for a visual presentation of audio content. Similarly, if the content is pure video, a blind person or a person with severe vision loss will miss the message without the important information in the video being described.

Remember from Section 2 that to be compliant with Section 508, you must include text equivalents for all non-text content. Besides including alternative text for images and image map areas, you need to provide textual equivalents for audio and more generally for multimedia content.

Some Definitions

A *transcript* of audio content is a word-for-word textual representation of the audio, including descriptions of non-text sounds like "laughter" or "thunder." Transcripts of audio content are valuable not only for persons with disabilities but in addition, they permit searching and indexing of that content which is not possible with just the audio. "Not possible" is, of course too strong. Search engines could, if they wanted, employ voice recognition to audio files, and index that information - but they don't.

When a transcript of the audio part of an audio-visual (multimedia) presentation is displayed synchronously with the audio-visual presentation, it is called *captioning*. When speaking of TV captioning, *open captions* are those in which the text is always present on the screen and *closed captions* are those viewers can choose to display or not.

Descriptive video or *described video* intersperses explanations of important video with the normal audio of a multimedia presentation. These descriptions are also called *audio descriptions*.

Wave Pad Audio Editing Software:

Professional sound editing software for PC & Mac

This **audio editing software** is a full featured professional audio and music editor for Windows and Mac OS X. It lets you record and edit music, voice and other audio recordings. When **editing audio** files you can cut, copy and paste parts of recordings then **add effects** like echo, amplification and noise reduction. WavePad works as a **wav or mp3 editor** but it also supports a number of other file formats including vox, gsm, wma, real audio, au, aif, flac, ogg and more.

Typical Audio Editing Applications

- Software audio editing for studios and professional journalists.
- Edit sound files to broadcast over the internet with the BroadWave Streaming Audio Server
- Normalizing the level of audio files during mastering before burning to CD.
- Editing mp3 files for your iPod, PSP or other portable device.
- As a music editor (includes ringtones creator formats).
- Music editing and recording to produce mp3 files.
- Voice editing for multimedia productions (use with our Video Editor).
- Restoration of audio files including removing excess noise such as hiss and hums.

System Requirements

- Works on **Windows XP** 2000/2003/Vista/2008 and Windows 7
- For earlier Windows versions (98, ME)
- Mac OS X 10.2 or later;
- Pocket PC 2003, Smartphone 2003 (Windows CE 4), Windows Mobile 5 Pocket PC / Smartphone, Windows Mobile 6
- To run under Linux use WINE.

UNIT – IV

VIDEO

INTRODUCTION:

Motion video is a combination of image and audio. It consists of a set of still images called **frames** displayed to the user one after another at a specific speed, known as the **frame rate** measured in number of frames per second(fps). The frame rate should range between 20 and 30 for perceiving smooth realistic motion. The recording and editing of sound has long been in the domain of the **PC**. This

is because of the enormous file size required by video. Thus, a 20 minute clip fills up 32 GB of disk space. The only solution to this problem is to **compress** the data, but compression hardware and software were very expensive in the early days of video editing. Motion video is conceptually similar to but physically different from motion picture. **Motion picture** is recorded on celluloid film and displayed in cinema theaters by projecting on a screen, whereas motion video is represented in the form of electrical signals as an output from video cameras. Motion video is also conceptually similar to **animation**, the difference being that while video represents a sequence of real world images captured by a movie camera.

ANALOG VIDEO CAMERA:

Analog video cameras are used to record a succession of still images and then convert the brightness and color information of the images into electrical signals. The **tube type analog video camera** is generally used in professional studios and uses electron beams to scan in a raster pattern, while the **CCD video camera**, using a light-sensitive electronic device called the CCD, is used for home/office purposes where portability is important.

Monochrome Video Camera:

The essential components of an analog video camera consist of a vacuum tube containing an electron gun, and a photo-sensitive semi-conductor plate called Target in front. A lens in front of the Target focuses light from an object on to the Target. The positive terminal of a battery is connected to the lens side of the Target while the negative terminal is attached to the cathode of the electron gun.(fig)

The target is almost an insulator in the absence of light. The electrons migrate towards a positive potential applied to the lens side of the target. This positive potential is applied to a thin layer of conductive but transparent material. The vacant energy states left by the liberated electrons, called holes, migrate towards the inner surface of the target. Thus, a charge pattern appears on the inner surface of the target that is most positive where the brightness or luminosity of the scene is the greatest.

The charge pattern is sampled point-by-point by a moving beam of electrons which originates in an electron gun in the tube. Excess electrons are turned back towards the source. The exact number of electrons needed to neutralize the charge pattern constitutes a flow of current in a series circuit. It is this current flowing across a load resistance that forms the output signal voltage of the tube.

Color Video Camera:

Fig. shows a block diagram of a color TV camera. It essentially consists of three camera tubes in which each tube receives selectively filtered primary colors. Each camera tube develops a signal voltage proportional to the respective color intensity received by it. Light from the scene is processed by the

objective lens system. The image formed by the lens is split into three images by glass prisms. These prisms are designed as dichroic mirrors. A dichroic mirror passes one wavelength and rejects other wavelengths. Thus, red, green and blue images are formed. This generates the three color signals V_r, V_g, V_b the voltage levels of which are proportional to the intensity of the colored light falling on the specific tube.

TRANSMISSION OF VIDEO SIGNALS:

Problems in Transmitting Color Signals:

A color video camera produces three color signals corresponding to the R,G,B components to the R,G,B components of the color image. These signals must be combined in a monitor to reproduce the original image. Such a scheme is suitable when the monitor is close to the camera, and three cables could be used to transmit the signals from the camera to the monitor. Firstly, it requires three separate cables or wires or channels which increases the cost of the setup for large distances. Secondly, it was found difficult to transmit the cables at exact synchronism with each other so that they arrived at the same instant at the receiving end. Thirdly, for TV signals, the transmission scheme had to adapt to the existing monochrome TV transmission set up. Additionally it provided a means of compressing the data during transmission for reducing the bandwidth requirements.

Color Perception Curve:

All objects that we observe are focused sharply by the lens system of the human eye on the retina. The retina which is located at the back side of the eye has light sensitive cells which capture the visual sensations. The retina is connected to the optic nerve which conducts the light stimuli to the optical centre of the brain. According to the theory formulated by Helmholtz the light sensitive cells are of two types – rods and cones. The rods provide brightness sensation and thus, perceive objects in various shades of grey from black to white. The cones are sensitive to color and can broadly be classified into three different groups. The combined relative luminosity curve showing relative sensation of brightness produced by individual spectral colors is shown in fig.8.4.

Thus, One lumen (lm) of white light = 0.3lm of red+0.59lm of green+0.11lm of blue=0.89lm of yellow+0.11lm of blue = 0.7lm of cyan+0.3lm of red = 0.41lm of magenta +0.59lm of green.

Luminance and Chrominance:

The RGB model is used mainly in color image acquisition and display. The luminance-chrominance color system is more efficient and hence widely used. This has something to do with color perception of the HVS (human visual system). It is known that the HVS is more sensitive to green than red and the least sensitive to blue.

The **luminance** component, describes the variation of perceived brightness by the HVS in different portion of the image without regard to any color information.

The **chrominance** component, describes the variation of color information in different parts of the image without regard to any brightness information. It is denoted by C and consists of two sub-components: hue (H) which is the actual name of the color, e.g. red, and saturation (S) which denotes the purity of the color.

An image may be thought to be composed of two separate portions, a luminance component and a chrominance component, which when superimposed on each other produce the final image that we see. Separately both the luminance and chrominance components look like grayscale images, similar to R,G,B color channels in an image processing software like Adobe Photoshop.

Generating YC signals from RGB:

The RGB output signals from a video camera are transformed to YC format using electronic circuitry before being transmitted. For a color TV, the YC components are again converted back to RGB signals which are used to drive the electron guns of a CRT. As a first estimation the brightness (Y) component can be taken as the average of R,G, and B. However from the color perception curve above we see that the human eye is more sensitive to the green part of the spectrum than to the red and blue. The relation between Y and RGB which is used unanimously nowadays is shown as:

$$Y=0.3R + 0.59G + 0.11B$$

This states that the brightness of an image is composed of 30% of red information, 59% of green information and 11% of blue information.

The C sub-components, ie. H and S, are quantitatively defined in terms of **color difference** signals referred to as **blue chrominance** C_b and **red chrominance** C_r . These are defined as:

$$C_b = B - Y$$

$$C_r = R - Y$$

Chroma Sub-sampling

Conversion of RGB signals into YC format also has another important advantage of utilizing less bandwidth through the use of chroma sub sampling. Studies on visual perception of the eye have shown that the human eye is less sensitive to color information. This limitation is exploited to transmit reduced color information as compared to brightness information, a process called **chroma sub-sampling**, and save on bandwidth requirements. There can be different schemes of chroma sub-sampling described as follows.

4:2:2 These numbers indicate the amount of luminance and chrominance transmitted from the video camera to the TV receiver set. It implies that when the signal is converted into an image on the TV screen, out of 4 pixels containing luminance information (Y), only 2 pixels contain color sub-component 1(C_b) and 2 pixels contain color sub-component 2(C_r). The reduction in color information helps to reduce bandwidth of the transmitted signal (fig 8.9a).

4:1:1 This scheme indicates a still further reduction in color information in the transmitted signal. The image produced by the signal contains only one-fourth of the original color information, i.e. out of 4 pixels containing luminance information (Y), only 1 pixel contains color sub-component 1(C_b) and 1 pixel contains color sub-component 2(C_r). Hence this scheme produces a greater loss in color information than the 4:2:2 scheme (fig 8.9b).

4:4:4 This scheme implies that there is no chroma sub-sampling at all, i.e. out of 4 pixels containing luminance information (Y), all 4 pixels contain color sub-component 1(C_b) and all 4 pixels contain color sub-component 2(C_r). There is no loss in color component and hence the picture is of the best quality, although the signal would have the highest bandwidth (Fig. 8.9c)

4:2:0 In all the above cases sub-sampling is only done along a row of pixels, i.e. horizontally, but not vertically along a column. The 4:2:0 scheme indicates both horizontal and vertical sub-sampling, it implies that out of 4 pixels containing luminance information (Y), only 2 pixels contain color sub-component 1(C_b) and 2 pixels contain color sub-component 2(C_r), both along a row as well as along a column (Fig 8.9d). Hence the amount of information loss is double that of the 4:2:2 scheme and comparable to the 4:1:1 scheme.

VIDEO SIGNAL FORMATS

Component Video:

This refers to a video signal which is stored or transmitted as three separate component signals. The simplest form is the collection of R, G and B signals which usually form the output of analog video cameras. Three separate wires and connectors are usually used to convey such signals from the camera to another device for storage or playback. R, G, B signals are replaced by Y, C_b and C_r signals, also delivered along three separate wires.

Composite video:

For ease of signal transmission, especially TV broadcasting, as also to reduce cable/channel requirements, component signals are often combined into a single signal which is transmitted along a single wire or channel. This is referred to as composite video. In this case the total bandwidth of the channel is split into separate portions and allowed for the luminance and chrominance parts. Since the human eye is more sensitive to luminance changes than color

changes, luminance is allotted a greater bandwidth than the chrominance parts. However single cable is used, this leads to cost savings.

S-Video:

Short for **super-video**. An analog video signal format where the luminance and chrominance portions are transmitted separately using multiple wires instead of the same wire as for composite video. The connector used is a 4-pin mini-DIN connector with 75ohm termination impedance.

SCART Connector:

SCART (Syndicat des Constructeurs d' Appareils Radiorecepteurs et Televiseurs) is a French standard of a 21-pin audio and video connector. It can be used to connect VCR's, DVD players, set top boxes, game systems and computers to television sets. SCART attempts to provide a standardized connector containing all the signals for audio video applications across different manufacturers. SCART connectors are non-locking and may become loose or fall off, maximum cable length is 10 to 15m. Properly manufactured SCART connectors use coaxial cables to transmit audio/video signals, however cheaper versions may use plain wires resulting in degraded image quality.

DIGITAL VIDEO:

Analog video has been used for years in recording/editing studios and television broadcasting. For the purpose of incorporating video content in multimedia production, video needs to be converted into the digital format.

Full screen video only became a reality after the advent of the Pentium-II processor together with fast disks capable of delivering the required output. Even with these powerful resources delivering video files was difficult until the reduction in prices of compression hardware and software. Compression helped to reduce the size of video files to a great extent which required a lower bit-rate to transfer them over communication buses. Nowadays video is rarely viewed in the uncompressed form unless there is specific reason for doing so e.g., to maintain the high quality, as for medical analysis. The capture card is usually installed at the PC end. Alternatively the capture card can be inside a digital video camera which is capable of producing a digital video output and recording it onto a tape. The digital output from a digital video camera can also be fed to a PC after necessary format conversion.

DIGITAL VIDEO STANDARDS:

Let us first have a look at the existing digital video standards for transmission and playback.

Enhanced Definition Television Systems (EDTV)

These are conventional systems modified to offer improved vertical and horizontal resolutions. One of the systems emerging in US and Europe is known as the **Improved Definition Television (IDTV)**. IDTV is an attempt to improve NTSC image by using digital memory to double the scanning lines from 525 to 1050. The **Double Multiplexed Analog Components (D2-MAC)** standard is designed as an intermediate standard for transition from current European analog standard to HDTV standard

CCIR (ITU-R) Recommendations

The international body for television standards, the International Telecommunications Union – Radio communications Branch (ITU-R) formerly known as the Consultative Committee for International Radio communications (CCIR), defined a standard for digitization of video signals known as **CCIR-601 Recommendations**. A color video signal has three components – a luminance component and two chrominance components. The CCIR format has two options: one for NTSC TV and another for PAL TV systems both of them being interlaced formats.

Common Intermediate Format (CIF)

CIF is a non-interlaced format. Its luminance resolution has 360X288 pixels/frame at 30 frames/second and the chrominance has half the luminance resolution in both horizontal and vertical directions. SIF is usually used for video-conferencing applications.

$$Y=360 \times 288, C_b=C_r=180 \times 144$$

QCIF (Quarter-CIF) is usually used in video-telephony applications

$$Y=180 \times 144, C_b=C_r=90 \times 72$$

Source Input Format (SIF)

SIF has luminance of 360 X 240 pixels/frame at 30 frames/second or 360 X 288 pixels/frame at 25 frames/second. SIF can be easily obtained from the CCIR format using sub-sampling,

$$Y=360 \times 240, C_b=C_r=180 \times 120$$

$$Y=360 \times 288, C_b=C_r=180 \times 144$$

High Definition (HD) Video and HDTV

High Definition (HD) video is a new standard for digital video for improving picture quality compared to the standard NTSC or PAL formats. They require a high definition monitor or TV screen (HDTV) to be viewed and have been defined as the **ITU-R** recommendations formerly known as **CCIR** (Consultative Committee for International Radiocommunications). There are two alternate formats one relating to the standard 4:3 aspect ratio screens with 1440 X 1152 pixels. Both use either 4:2:2 sub-sampling scheme for studio applications with 50/60 Hz frame refresh rate, or 4:2:0 scheme for broadcast applications with 25/30 Hz refresh rate.

PC VIDEO

The TV screens display video as 720 columns by 480 rows or 720 columns by 576 rows(PAL) using a sampling rate of 13.5MHz as per the CCIR recommendations. In order to avoid distortion on a PC screen it was necessary to use a horizontal addressability of 640 for NTSC and 768 for PAL.

Analog video needs to be converted to the digital format before it can be displayed on a PC screen. The procedure for conversion involves two types of devices – source devices and capture devices, as detailed below.

1. Source and Source Devices

‘Source’ implies the media on which analog video is recorded. In most cases these are magnetic tape, i.g. VHS tape. Video recorded onto a source must conform to one of the video recording standards i.e. either NTSC or PAL. Outputs from a source device must conform to one of the video signal standards i.e. either component video or composite video or S-video.

The source and source device can be one of the following:

- Camcorder with pre-recorded video tape
- VCP with pre-recorded video cassette
- Video camera with live footage.

2. Video Capture Card

A video capture device is essentially an expansion board that can handle a variety of different audio and video input signals and convert them from analog to digital or vice versa. A typical circuit board consists of the following components:

- ..Video INPUT port to accept the video input signals from NTSC/PAL/SECAM broadcast signals, video camera or VCR. The input port may conform to the composite-video or S-video standards.
- Video compression-decompression hardware for video data.
- Audio compression-decompression hardware for audio data.
- A/D converter to convert the analog input video signals to digital form.
- Video OUTPUT port to feed output video signals to camera and VCR.
- D/A converter to convert the digital video data to analog signals for feeding to output analog devices.
- Audio INPUT/OUTPUT ports for audio input and output functions.

A video capture card is also sometimes referred to as a **video frame grabber**. The overview of the main components are:

- **Video Channel Multiplexer:** Since a video capture card supports a number of input ports, e.g. composite video, S-video and a number of input formats, e.g. NTSC, PAL, HDTV, a video channel multiplexer allows the proper input port and format to be selected under program control and enables the circuitry appropriate for the selected channel.
- **ADC:** The Analog to Digital Converter (ADC) reads the input analog video signal from an analog video camera or VCP, and digitizes it using standard procedures of sampling and quantization. The parameters for digitization include the sampling rate for the visual and audio portions, the color depth and the frame rate. The sampling rate for the audio portion is usually chosen as CD-quality, i.e.44.1 KHZ, 16-bit, stereo.
- **Image Processing Parameters:** Image processing parameters include specifying the brightness, contrast, color, audio volume, etc. which are specified using the video capture software. These parameters are changed using a lookup table which converts the value of an input pixels or audio sample in a pre-defined way and writes it to an appropriate frame buffer of the capture card.

- **Compression Decompression:** The video capture card often contains a chip for hardware compression and decompression of video data in real time. There can be multiple standards like MPEG-1, MPEG-2, H.261/263, which would require a programmable CODEC on the card.

3. Video Capture Software

- **Tuning Parameters**
- **AVI capture**
- **AVI to MPEG Converter**
- **MPEG Capture**
- **DAT to MPEG Converter**
- **MPEG Editor**

VIDEO FILE FORMATS AND CODECS

- **AVI (Audio/Video Interleaved)**
- **MOV (QuickTime Movie)**
- **MPEG (Motion Pictures Experts Group)**
- **Real Video**
- **H.261**
- **H.263**
- **Indeo Video Interactive**
- **Cinepak**
- **Sonenson Video**
- **VDOLive**
- **DivX**
- **XviD**
- **Windows Media Video (WMV)**

VIDEO EDITING:

- **Online and Offline Editing**
- **SMPTE Time Code**

- **Timebase**
- **Edit Decision List(EDL)**

VIDEO EDITING SOFTWARE

- **Importing Clips**
- **Timeline Structure**
- **Playback of Clips**
- **Trimming Clips**
- **Splitting a Clip**
- **Manipulating the Audio Content**
- **Adding Transitions**
- **Changing the speed of a Clip**
- **Changing the Opacity of a Clip**
- **Applying Special Effects**
- **Superimposing an Image**
- **Exporting a Movie**

CONCLUSION:

While editing and exporting digital video, a concept which needs to be understood is called **rendering**. A video editor provides us with a visual interface where we can click and drag to specify editing operations on video operations. This process of physically changing the data based on some instruction given via an interface is known as rendering. Depending on the amount of video data and the nature of operations rendering may often span for several hours and even for days. In most cases AVI and MOV formats are usually supported, in some cases creating other formats like MPG may also be possible.

