

# 34 ELECTRIC CURRENT

## Objectives

- Describe the flow of electric charge. (34.1)
- Describe what is happening inside a current-carrying wire. (34.2)
- Give examples of voltage sources. (34.3)
- Describe the factors that affect the resistance of a wire. (34.4)
- Describe Ohm's law. (34.5)
- Explain the causes of electric shock. (34.6)
- Distinguish between DC and AC (34.7).
- Describe how AC is converted to DC. (34.8)
- Describe the drift speed of conduction electrons in a current-carrying wire. (34.9)
- Identify the source of conduction electrons in a circuit. (34.10)
- Relate the electric power used by a device to current and voltage. (34.11)

## discover!

**MATERIALS** paper towel, vinegar (or salt solution), dime, penny, galvanometer

**EXPECTED OUTCOME** The cell produces a voltage.

### ANALYZE AND CONCLUDE

1. Reversing the leads reverses the deflection of the galvanometer needle.
2. Connecting a number of the cells in series would increase the voltage produced.
3. A battery consists of electrical cells connected in series.

# 34 ELECTRIC CURRENT



## THE BIG IDEA

Electric current is related to the voltage that produces it and the resistance that opposes it.

The previous chapter discussed the concept of electric potential, or voltage, in terms of energy per charge. We'll see in this chapter that voltage can be thought of as an "electric pressure" that produces a flow of charge, or *current*, within a conductor. The flow is restrained by the *resistance* it encounters. When the flow takes place along one direction, it is called *direct current* (DC); when the charges flow to and fro, it is called *alternating current* (AC). The rate at which energy is transferred by electric current is *power*. These ideas are better understood if you know how they relate to one another. Let's begin with the flow of electric charge.



## discover!

### How Can You Make a Simple Voltage Source?

1. Soak a piece of paper towel in a salt solution or vinegar and place it between a dime and a penny.
2. Attach one lead from a galvanometer to each of the coins.
3. Now attach the lead that was originally attached to the dime to the penny, and vice versa.

### Analyze and Conclude

1. **Observing** Describe the galvanometer reading when the leads were brought in contact with the coins. What happened when the leads were reversed?
2. **Predicting** What do you think would happen if a number of these dime-and-penny cells were connected in series? (That is, placed end to end with dimes touching pennies.)
3. **Making Generalizations** How do you think voltage sources such as the batteries used in portable electronic devices are constructed?

## 34.1 Flow of Charge

Recall that heat flows through a conductor when a difference in temperature exists between its ends. Heat flows from the end of higher temperature to the end of lower temperature. When both ends reach the same temperature, the flow of heat ceases.

Charge flows in a similar way. ✓ **When the ends of an electric conductor are at different electric potentials, charge flows from one end to the other.** Charge flows when there is a **potential difference**, or difference in potential (voltage), between the ends of a conductor. The flow of charge will continue until both ends reach a common potential. When there is no potential difference, there is no longer a flow of charge through the conductor. As an example, if one end of a wire were connected to the ground and the other end placed in contact with the sphere of a Van de Graaff generator that is charged to a high potential, a surge of charge would flow through the wire. The flow would be brief, however, for the sphere of the generator would quickly reach a common potential with the ground.

To attain a sustained flow of charge in a conductor, some arrangement must be provided to keep one end at a higher potential than the other. The situation is analogous to the flow of water from a higher reservoir to a lower one, as shown in Figure 34.1a. Water will flow in a pipe that connects the reservoirs only as long as a difference in water level exists. The flow of water in the pipe, like the flow of charge in the wire that connects the Van de Graaff generator to the ground, will cease when the “pressures” at the two ends are equal. In order that the flow be sustained, there must be a suitable pump of some sort to maintain a difference in water levels, as shown in Figure 34.1b. Then there will be a continual difference in water pressures and a continual flow of water. The same is true of electric current.

**CONCEPT:** What happens when the ends of a conductor are at different electrical potentials?  
**CHECK:**

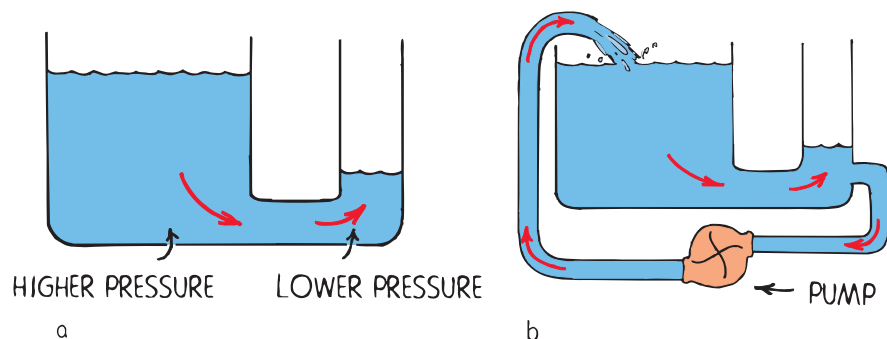

◀ **FIGURE 34.1**  
a. Water flows from higher pressure to lower pressure. The flow will cease when the difference in pressure ceases. b. Water continues to flow because a difference in pressure is maintained with the pump.

Electrons in a wire are like water in a pipe; whenever a little water enters one end, almost immediately the same amount of water exits the other end.



The purpose of this chapter is to build a good understanding of electric current and to dispel some of the common misconceptions about electricity. If you are teaching only one chapter on electricity, this should be it.

PAUL

## 34.1 Flow of Charge

### Key Term

potential difference

► **Teaching Tip** Explain the lighting of a fluorescent lamp or neon discharge tube by the Van de Graaff generator from the previous chapter in terms of current being directly proportional to a difference in voltage. One end of the lamp was in a stronger part of the energy field than the other. There was more energy per charge on one end than the other and so more voltage at one end than the other, providing the potential difference.

**CONCEPT:** When the ends of a conductor are at different electric potentials, charge flows from one end to the other.

### Teaching Resources

- Reading and Study Workbook
- PresentationEXPRESS
- Interactive Textbook
- Next-Time Question 34-1



## 34.2 Electric Current

### Key Terms

ampere, electric current

► **Teaching Tip** Explain that the ampere is named after physicist André-Marie Ampère (1775–1836).

► **Teaching Tip** Have your students imagine a tube completely filled with Ping-Pong balls. As one more ball is pushed into one end, one ball comes out the other. This should help them understand that a current-carrying wire has no net charge.

► **Teaching Tip** Write *current ~ voltage difference* ( $I \sim V$ ) on the board. This is the lead-in to Ohm's law. Make sure students understand that a potential difference can cause a flow of charge.

Strictly speaking, the voltage term in Ohm's law implies the difference in potential, so voltage difference is redundant, but it underscores a point that may be missed, so go for it.

A high moment in my life was a conversation with Richard Feynman about teaching physics conceptually. The topic of redundancies in teaching electricity came up. Feynman advised me to put concepts above grammar, and go for redundancies when they underscore a point—so it's okay to say "current flows in a circuit!"

PAUL

**CONCEPT CHECK**: A current-carrying wire has a net electric charge of zero.

### Teaching Resources

- Conceptual Physics Alive! DVDs *Electric Current*

## 34.2 Electric Current

**Electric current** is the flow of electric charge. In solid conductors the electrons carry the charge through the circuit because they are free to move throughout the atomic network. These electrons are called *conduction electrons*. Protons, on the other hand, are bound inside atomic nuclei that are more or less locked in fixed positions within the conductor. In fluids, such as the electrolyte in a car battery, positive and negative ions as well as electrons may compose the flow of electric charge.

**Measuring Current** Electric current is measured in **amperes**, for which the SI unit is symbol A.<sup>34.2</sup> An ampere is the flow of 1 coulomb of charge per second. (Recall that 1 coulomb, the standard unit of charge, is the electric charge of 6.24 billion billion electrons.) In a wire that carries a current of 5 amperes, for example, 5 coulombs of charge pass through any cross section in the wire each second. That's a lot of electrons! In a wire that carries 10 amperes, twice as many electrons pass any cross section each second. Figure 34.2 shows a simplified view of electrons flowing in a wire.

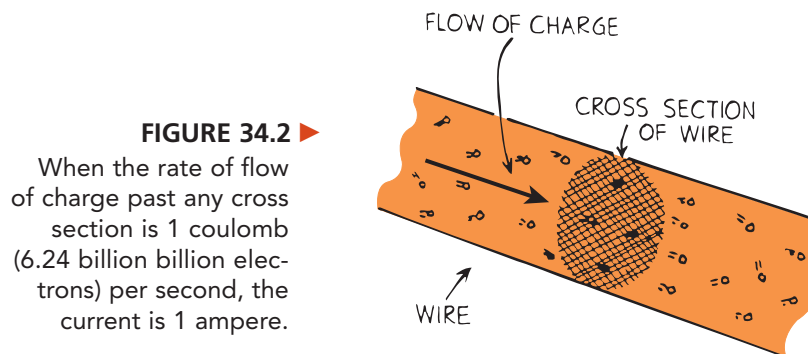

**Net Charge of a Wire** ✓ A current-carrying wire has a net electric charge of zero. While the current is flowing, negative electrons swarm through the atomic network that is composed of positively charged atomic nuclei. Under ordinary conditions, the number of electrons in the wire is equal to the number of positive protons in the atomic nuclei. When electrons flow in a wire, the number entering one end is the same as the number leaving the other. So we see that the net charge of the wire is normally zero at every moment.

**CONCEPT CHECK**: What is the net flow of electric charge in a current-carrying wire?

## 34.3 Voltage Sources

Charges do not flow unless there is a potential difference. A sustained current requires a suitable “electric pump” to provide a sustained potential difference. Something that provides a potential difference is known as a **voltage source**.

If you charge a metal sphere positively, and another negatively, you can develop a large voltage between them. This is not a good voltage source because when the spheres are connected by a conductor, the potentials equalize in a single brief surge of moving charges. It is not practical. Batteries and generators, however, are capable of maintaining a continuous flow.

**Steady Voltage Sources** ✓ Voltage sources such as batteries and generators supply energy that allows charges to move steadily.

In a battery, a chemical reaction occurring inside releases electrical energy.<sup>34.3.1</sup> Generators—such as the alternators in automobiles—convert mechanical energy to electrical energy, as will be discussed in Chapter 37. The electrical potential energy produced by whatever means is available at the terminals of the battery or generator. The potential energy per coulomb of charge available to electrons moving between terminals is the voltage (sometimes called the *electromotive force*, or *emf*). The voltage provides the “electric pressure” to move electrons between the terminals in a circuit.

Power utilities use electric generators to provide the 120 volts delivered to home outlets. The alternating potential difference between the two holes in the outlet averages 120 volts. When the prongs of a plug are inserted into the outlet, an average electric “pressure” of 120 volts is placed across the circuit connected to the prongs. This means that 120 joules of energy is supplied to each coulomb of charge that is made to flow in the circuit.

**Distinguishing Between Current and Voltage** There is often some confusion between charge flowing *through* a circuit and voltage being impressed *across* a circuit. To distinguish between these ideas, consider a long pipe filled with water. Water will flow *through* the pipe if there is a difference in pressure *across* the pipe or between its ends. Water flows from the high-pressure end to the low-pressure end. Only the water flows, not the pressure. Similarly, charges flow *through* a circuit because of an applied voltage *across* the circuit.<sup>34.3.2</sup> You don’t say that voltage flows through a circuit. Voltage doesn’t go anywhere, for it is the charges that move. Voltage causes current.

**CONCEPT:** What are two voltage sources used to provide the **CHECK:** energy that allows charges to move steadily?



**FIGURE 34.3** ▲ Each coulomb of charge that is made to flow in a circuit that connects the ends of this 1.5-volt flashlight cell is energized with 1.5 joules.

## 34.3 Voltage Sources

### Key Term

voltage source

► **Teaching Tip** Relate voltage to the idea of electrical pressure. Emphasize that a *difference* in electric potential (or voltage difference) must exist. Explain how a battery provides this difference in a sustained way compared to the sudden discharge of a Van de Graaff generator. Generators at power plants provide a voltage difference across wires that carry this difference to consumers.

► **Teaching Tip** Point out that voltage obtained from dry cells or wet cells is no different from that obtained from a DC generator. Voltage is voltage, regardless of source!

**CONCEPT:** Batteries and **CHECK:** generators supply energy that allows charges to move steadily.

**Go Online**  
SCILINKS™  
NSTA

For: Links on batteries  
Visit: [www.SciLinks.org](http://www.SciLinks.org)  
Web Code: csn - 3403

### Teaching Resources

- Reading and Study Workbook
- PresentationEXPRESS
- Interactive Textbook



## 34.4 Electric Resistance

### Key Terms

electric resistance, ohm

► **Teaching Tip** Introduce the idea of electrical resistance, and complete the equation  $I = V/R$ . This is Ohm's law.

► **Teaching Tip** Compare the resistances of various materials, and the resistances of various thicknesses of wires of the same metal. Call attention to the glass supports on wires that make up high-voltage power lines and the rubber insulation that separates the pair of wires in a common lamp cord.

► **Teaching Tip** Distinguish between the voltage *across* a conductor, the current *through* a conductor, and the resistance *between* the ends of a conductor.

► **Teaching Tip** In Figure 34.5, note that opening the switch is equivalent to inserting an infinite resistance.

**CONCEPT CHECK** The resistance of a wire depends on the conductivity of the material used in the wire and also on the thickness and length of the wire.

### Teaching Resources

- Reading and Study Workbook
- Problem-Solving Exercises in Physics 17-1
- Transparency 80
- Presentation EXPRESS
- Interactive Textbook

FIGURE 34.4 ▼

For a given pressure, more water passes through a large pipe than a small one. Similarly, for a given voltage, more electric current passes through a large-diameter wire than a small-diameter one.

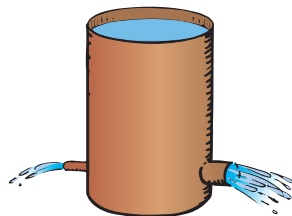

A material with a low resistance has a high conductivity.



## 34.4 Electric Resistance

The amount of charge that flows in a circuit depends on the voltage provided by the voltage source. The current also depends on the resistance that the conductor offers to the flow of charge—the **electric resistance**. This is similar to the rate of water flow in a pipe, which depends not only on the pressure difference between the ends of the pipe but on the resistance offered by the pipe itself, as shown in Figure 34.4. ✓ **The resistance of a wire depends on the conductivity of the material used in the wire (that is, how well it conducts) and also on the thickness and length of the wire.**

Thick wires have less resistance than thin wires. Longer wires have more resistance than short wires. In addition, electric resistance depends on temperature. The greater the jostling about of atoms within the conductor, the greater resistance the conductor offers to the flow of charge. For most conductors, increased temperature means increased resistance.<sup>34.4.1</sup>

The resistance of some materials becomes zero at very low temperatures, a phenomenon known as **superconductivity**. Certain metals acquire superconductivity (zero resistance to the flow of charge) at temperatures near absolute zero. Since 1987, superconductivity at “high” temperatures (above 100 K) has been found in a variety of nonmetallic compounds. Once electric current is established in a superconductor, the electrons flow indefinitely.

Electric resistance is measured in units called **ohms**,<sup>34.4.2</sup> after Georg Simon Ohm (1789–1854), a German physicist who tested different wires in circuits to see what effect the resistance of the wire had on the current.

**CONCEPT CHECK** What factors affect the resistance of a wire?

FIGURE 34.5 ►

A simple hydraulic circuit is analogous to an electric circuit.

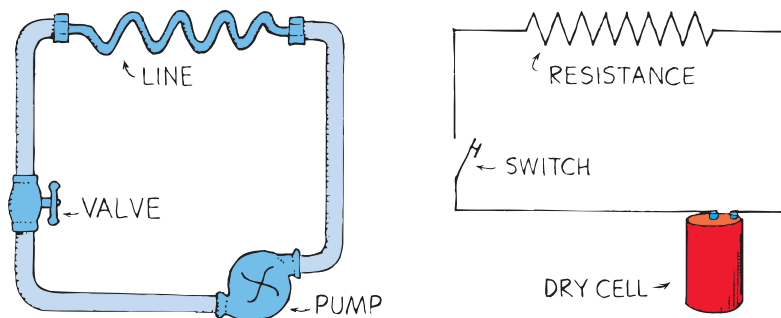

## 34.5 Ohm's Law

The relationship among voltage, current, and resistance is called **Ohm's law**.<sup>34.5</sup> ✓ Ohm's law states that the current in a circuit is directly proportional to the voltage impressed across the circuit, and is inversely proportional to the resistance of the circuit. In short,

$$\text{current} = \frac{\text{voltage}}{\text{resistance}}$$

The relationship among the units of measurement for these three quantities is as follows:

$$1 \text{ ampere} = 1 \frac{\text{volt}}{\text{ohm}}$$

For a given circuit of constant resistance, current and voltage are proportional. This means that you'll get twice the current through a circuit for twice the voltage across the circuit. The greater the voltage, the greater the current. But if the resistance is doubled for a circuit, the current will be half what it would be otherwise. The greater the resistance, the less the current. Ohm's law makes good sense.



◀ **FIGURE 34.6**

The stripes on these resistors are color coded to indicate the resistance in ohms.

Using specific values, a potential difference of 1 volt impressed (imposed) across a circuit that has a resistance of 1 ohm will produce a current of 1 ampere. If a voltage of 12 volts is impressed across the same circuit, the current will be 12 amperes.

The resistance of a typical lamp cord is much less than 1 ohm, while a typical lightbulb has a resistance of about 100 ohms. An iron or electric toaster has a resistance of 15 to 20 ohms. The low resistance permits a large current, which produces considerable heat. The current inside electric devices such as radio and television receivers is regulated by circuit elements called *resistors*, whose resistance may range from a few ohms to millions of ohms.

**CONCEPT CHECK:** What does Ohm's law state?



Using  $I$  for current,  $V$  for voltage, and  $R$  for resistance, Ohm's law reads  $I = V/R$ .

## 34.5 Ohm's Law

### Key Term

Ohm's law

Ohm's law is the core of the chapter. No distinction is made between resistors that change their value when voltage changes and those that don't. We simply say that whatever the conductor, the amount of current produced by an impressed voltage is equal to that voltage divided by the particular resistance. Ohm's law is conceptually useful.

PAUL

► **Teaching Tip** As a practical matter, Ohm's law is useful for predicting values only if the resistance of the device does not change with changes in voltage or current, for instance where heating does not appreciably affect resistance. Devices that keep the same resistance for a wide range of voltages are said to be "ohmic." Ohm's law is useful for predicting values of ohmic materials.

### think!

How much current is drawn by a lamp that has a resistance of 100 ohms when a voltage of 50 volts is impressed across it?

Answer: 34.5

**CONCEPT CHECK:** Ohm's law states that the current in a circuit is directly proportional to the voltage impressed across the circuit, and is inversely proportional to the resistance of the circuit.

### Teaching Resources

- Concept-Development Practice Book 34-1
- Laboratory Manual 93



## Demonstration

Using a pair of rigid brass or copper rods, set up a 12-V car battery (or other large battery) with extended terminals as shown. (See the comic strip “Parallel Circuit” on page 708.)

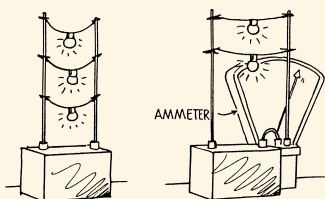

The 12-V potential difference between the terminals is the same across the rods. The rods behave as the lead wires in common circuits—they simply extend the difference in potential to distant locations. With alligator clips, connect two or three lamps of equal resistance to a battery and relate the current, as evidenced by the emitted light, to the voltage of the battery and the resistance of the lamps. (Be sure the lamps are not bright enough to make viewing uncomfortable.) Interchange lamps of low and high resistance and relate resistance to the brightness of the lamps.

## 34.6 Ohm's Law and Electric Shock

► **Teaching Tip** Discuss the reason why electricians put one hand behind their back when probing questionable circuits. If they used two hands and happened to touch a live wire, current could go from one hand across the chest to the other hand, disrupting the heartbeat.

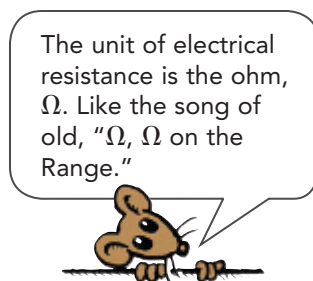

## 34.6 Ohm's Law and Electric Shock

What causes electric shock in the human body—current or voltage?

✓ **The damaging effects of electric shock are the result of current passing through the body.** From Ohm's law, we can see that this current depends on the voltage applied, and also on the electric resistance of the human body.

**The Body's Resistance** The resistance of your body depends on its condition and ranges from about 100 ohms if you're soaked with salt water to about 500,000 ohms if your skin is very dry. If you touched the two electrodes of a battery with dry fingers, the resistance your body would normally offer to the flow of charge would be about 100,000 ohms. You usually would not feel 12 volts, and 24 volts would just barely tingle. If your skin were moist, on the other hand, 24 volts could be quite uncomfortable. Table 34.1 describes the effects of different amounts of current on the human body.

**Table 34.1** Effect of Various Electric Currents on the Body

Current (amperes)	Effect
0.001	Can be felt
0.005	Painful
0.010	Involuntary muscle contractions (spasms)
0.015	Loss of muscle control
0.070	If through the heart, serious disruption; probably fatal if current lasts for more than 1 second

Many people are killed each year by current from common 120-volt electric circuits. If you touch a faulty 120-volt light fixture with your hand while you are standing on the ground, there is a 120-volt “electric pressure” between your hand and the ground. The soles of your shoes normally provide a very large resistance between your feet and the ground, so the current would probably not be enough to do serious harm. But if you are standing barefoot in a wet bathtub connected through its plumbing to the ground, the resistance between you and the ground is very small. Your overall resistance is lowered so much that the 120-volt potential difference may produce a harmful current through your body.

Drops of water that collect around the on/off switches of devices such as a hair dryer can conduct current to the user. Although distilled water is a good insulator, the ions in ordinary water greatly



**FIGURE 34.7 ▲**  
Handling a wet hair dryer can be like sticking your fingers into a live socket.

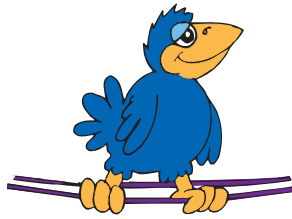

**FIGURE 34.8 ▲**  
The bird can stand harmlessly on one wire of high potential, but it better not grab a neighboring wire!

reduce the electric resistance. There is also usually a layer of salt left from perspiration on your skin, which when wet lowers your skin resistance to a few hundred ohms or less. Handling electric devices while taking a bath is extremely dangerous.

**High-Voltage Wires** You probably have seen birds perched on high-voltage wires like the one in Figure 34.8. Every part of the bird's body is at the same high potential as the wire, and it feels no ill effects. For the bird to receive a shock, there must be a *difference* in potential between one part of its body and another part. Most of the current will then pass along the path of least electric resistance connecting these two points.

Suppose you fall from a bridge and manage to grab onto a high-voltage power line, halting your fall. So long as you touch nothing else of different potential, you will receive no shock at all. Even if the wire is thousands of volts above ground potential and even if you hang by it with two hands, no charge will flow from one hand to the other. This is because there is no appreciable difference in electric potential between your hands. If, however, you reach over with one hand and grab onto a wire of different potential, ZAP!!

**Ground Wires** Mild shocks occur when the surfaces of appliances are at an electric potential different from that of the surfaces of other nearby devices. If you touch surfaces of different potentials, you become a pathway for current. To prevent this problem, the outsides of electric appliances are connected to a ground wire, which is connected to the round third prong of a three-wire electric plug, shown in Figure 34.9. All ground wires in all plugs are connected together through the wiring system of the house. The two flat prongs are for the current-carrying double wire. If the live wire accidentally comes in contact with the metal surface of an appliance, the current will be directed to ground rather than shocking you if you handle it.

**FIGURE 34.9 ▼**  
The third prong connects the body of the appliance directly to ground. Any charge that builds up on an appliance is therefore conducted to the ground.

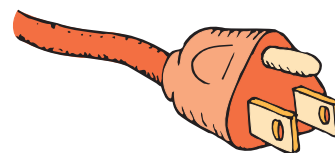

► **Teaching Tip** Give examples of voltage differences such as high-voltage wires, the third rail of electric-powered train tracks, and the inadvisability of using electric appliances in the bathtub.

► **Teaching Tip** Discuss how being electrified produces muscle contractions that account for such instances as “not being able to let go” of hot wires, and “being thrown” by electric shock. Explain that when electricians need to move wires that may be live, they first touch the wires with the back of the hand. In this way, any unexpected shocks that cause a muscular contraction will not cause their hands to grip the wire.

► **Teaching Tip** Discuss how the third prong on an electric plug provides a ground wire between the appliance and the ground. The ground prong is longer than the pair of flat prongs, so it will be first to be connected when it is plugged into a socket. Thus a ground connection is established just before the appliance is electrically connected. This path to ground prevents harm to the user if there is a short circuit in the appliance that would otherwise include the user as a path to ground.



**CONCEPT** : The damaging effects  
**CHECK** : of electric shock are  
the result of current passing  
through the body.

### Teaching Resources

- Reading and Study Workbook
- Presentation *EXPRESS*
- Interactive Textbook

## 34.7 Direct Current and Alternating Current

### Key Terms

alternating current, direct current

► **Teaching Tip** Discuss the differences between DC and AC. Compare the DC current that flows in a circuit powered with a battery to the AC current that flows in a household circuit (powered by a generator).



Ventricular fibrillation may be induced by only 0.06 A through the chest for a fraction of a second from a common 120-V circuit. Inducing the same effect with direct current requires about 0.3 to 0.5 A. If the current has a direct pathway to the heart (via a cardiac catheter or other electrodes), less than 0.001 A (AC or DC) can cause fibrillation.

**Health Effects** One effect of electric shock is to overheat tissues in the body or to disrupt normal nerve functions. It can upset the nerve center that controls breathing. In rescuing victims, the first thing to do is clear them from the electric power supply with a wooden stick or some other nonconductor so that you don't get electrocuted yourself. Then apply artificial respiration.

**CONCEPT** : What causes the damaging effects of electric shock?  
**CHECK** :

### think!

If the resistance of your body were 100,000 ohms, what would be the current in your body when you touched the terminals of a 12-volt battery?

Answer: 34.6.1

If your skin were very moist, so that your resistance was only 1000 ohms, and you touched the terminals of a 24-volt battery, how much current would you draw?

Answer: 34.6.2

## 34.7 Direct Current and Alternating Current

✓ **Electric current may be DC or AC.** By DC, we mean **direct current**, which refers to a flow of charge that *always flows in one direction*. A battery produces direct current in a circuit because the terminals of the battery always have the same sign of charge. Electrons always move through the circuit in the same direction, from the repelling negative terminal and toward the attracting positive terminal. Even if the current moves in unsteady pulses, so long as it moves in one direction only, it is DC.

**Alternating current** (AC), as the name implies, is electric current that repeatedly reverses direction. Electrons in the circuit move first in one direction and then in the opposite direction, alternating back and forth about relatively fixed positions. This is accomplished by alternating the polarity of voltage at the generator or other voltage source. Nearly all commercial AC circuits in North America involve voltages and currents that alternate back and forth at a frequency of 60 cycles per second. This is 60-hertz current. In some places, 25-hertz, 30-hertz, or 50-hertz current is used.

By plotting current over time, as shown in Figure 34.10, you can illustrate the difference between DC and AC. DC flows in only one direction over time; AC cycles back and forth over time.

**FIGURE 34.10** ▼

**a.** Direct current (DC) does not change direction over time. **b.** Alternating current (AC) cycles back and forth.

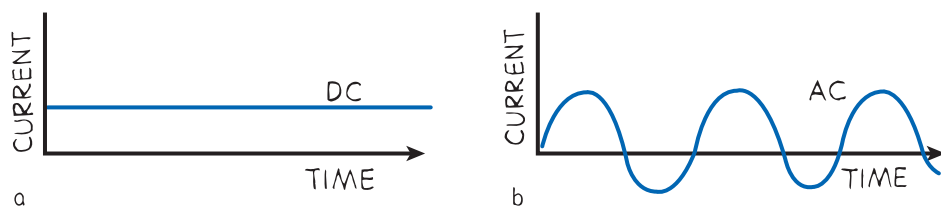

**Voltage Standards** Voltage of AC in North America is normally 120 volts.<sup>34.7.1</sup> In the early days of electricity, higher voltages burned out the filaments of electric lightbulbs. Tradition has it that 110 volts was settled on because it made bulbs of the day glow as brightly as a gas lamp. So the hundreds of power plants built in the United States prior to 1900 adopted 110 volts (or 115 or 120 volts) as their standard. By the time electricity became popular in Europe, engineers had figured out how to make lightbulbs that would not burn out so fast at higher voltages. Power transmission is more efficient at higher voltages, so Europe adopted 220 volts as their standard. The United States stayed with 110 volts (today officially 120 volts) because of the installed base of 110-volt equipment.

**Three-Wire Service** Although lamps in an American home operate on 110–120 volts, many electric stoves and other energy-hungry appliances operate on 220–240 volts. How is this possible? Because most electric service in the United States is three-wire: one wire at 120 volts positive, one wire at zero volts (neutral), and the other wire at a negative 120 volts. This is AC, with the positive and negative alternating at 60 hertz. A wire that is positive at one instant is negative 1/120 of a second later. Most home appliances are connected between the neutral wire and either of the other two wires, producing 120 volts. When the plus-120 is connected to the minus-120, a 240-volt jolt is produced—just right for electric stoves, air conditioners, and clothes dryers.<sup>34.7.2</sup>

The popularity of AC arises from the fact that electrical energy in the form of AC can be transmitted great distances with easy voltage step-ups that result in lower heat losses in the wires. Why this is so will be discussed in Chapter 37. The primary use of electric current, whether DC or AC, is to transfer energy quietly, flexibly, and conveniently from one place to another.

**CONCEPT CHECK:** What are the two types of electric current?

► **Teaching Tip** Use a hydrodynamic analogy for AC. Ask students to imagine powering a washing machine agitator with water power. Describe a pair of clear plastic pipes connected to a paddle wheel at the bottom of the agitator, designed so water sloshing to and fro in the pipes causes the agitator to twist to and fro. Suppose the free ends of the pipes are connected to a socket in the wall. The socket is connected to the power utility. It supplies no water (just as the power utilities supply no electrons), but consists of a couple of pistons that exert a pumping action, one out and the other in, and then vice versa, in rapid alternation. When the ends of the pipes containing water are connected to the pistons, the water in the pipes is made to slosh back and forth: power is delivered to the washing machine. The flowing substance, water or electrons, is supplied by you. The greater the load on the agitator, the more energy the power company must deliver to the action of the alternating pistons. This analogy creates a visual model for household current—especially with the transparent plastic pipes where your students can “see” the sloshing water!

**Go Online**  
SCILINKS™  
NSTA

For: Links on electric current  
Visit: [www.SciLinks.org](http://www.SciLinks.org)  
Web Code: csn - 3407

**CONCEPT CHECK:** Electric current may be AC or DC.

#### Teaching Resources

- Reading and Study Workbook
- PresentationEXPRESS
- Interactive Textbook

## 34.8 Converting AC to DC

### Key Term

diode

FIGURE 34.11 ▼

a. When input to a diode is AC, b. output is pulsating DC. c. Charging and discharging of a capacitor provides continuous and smoother current. d. In practice, a pair of diodes are used so there are no gaps in current output.

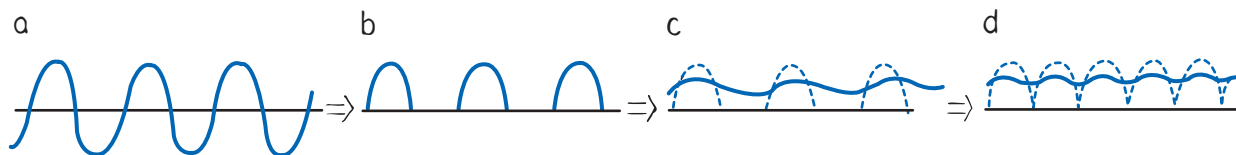

A familiar diode is the *light-emitting diode* (LED) seen on clocks and instrument panels. A solar cell is an LED in reverse—it absorbs light and produces electricity.



## 34.8 Converting AC to DC

The current in your home is AC. The current in a battery-operated device, such as a laptop computer or cell phone, is DC. ✓ **With an AC–DC converter, you can operate a battery-run device on AC instead of batteries.** In addition to a transformer to lower the voltage (Chapter 37), the converter uses a **diode**, a tiny electronic device that acts as a one-way valve to allow electron flow in only one direction. Since alternating current vibrates in two directions, only half of each cycle will pass through a diode (Figures 34.11a and 34.11b). The output is a rough DC, off half the time. To maintain continuous current while smoothing the bumps, a capacitor is used (Figure 34.11c).

Recall from the previous chapter that a capacitor acts as a storage reservoir for charge. Just as it takes time to raise or lower the water level in a reservoir, it takes time to add or remove electrons from the plates of a capacitor. A capacitor therefore produces a retarding effect on changes in current flow. It smooths the pulsed output.

**CONCEPT CHECK:** How can you operate a battery-run device on AC?

**CONCEPT CHECK:** With an AC–DC converter, you can operate a battery-run device on AC instead of batteries.

### Teaching Resources

- Reading and Study Workbook
- PresentationEXPRESS
- Interactive Textbook

FIGURE 34.12 ►  
Diodes are tiny devices that allow electrons to flow in only one direction.

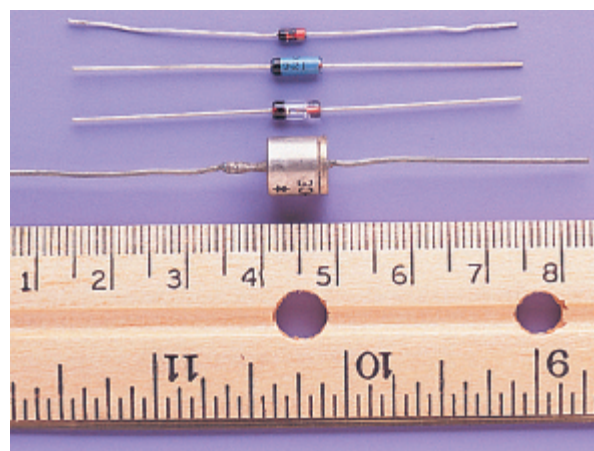

## 34.9 The Speed of Electrons in a Circuit

When you flip on the light switch on your wall and the circuit is completed, the lightbulb appears to glow immediately. Energy is transported through the connecting wires at nearly the speed of light. The electrons that make up the current, however, do not move at this high speed.

At room temperature, the electrons inside a metal wire have an average speed of a few million kilometers per hour due to their thermal motion. This does not produce a current because the motion is random. There is no net flow in any one direction. But when a battery or generator is connected, an electric field is established inside the wire. It is a pulsating electric field that can travel through a circuit at nearly the speed of light. The electrons continue their random motions in all directions while simultaneously being nudged along the wire by the electric field.

The conducting wire acts as a guide or “pipe” for electric field lines, as you can see in Figure 34.13. In the space outside the wire, the electric field has a pattern determined by the location of electric charges, including charges in the wire. Inside the wire, the electric field is directed along the wire. If the voltage source is DC, like the battery shown in Figure 34.13, the electric field lines are maintained in one direction in the conductor.

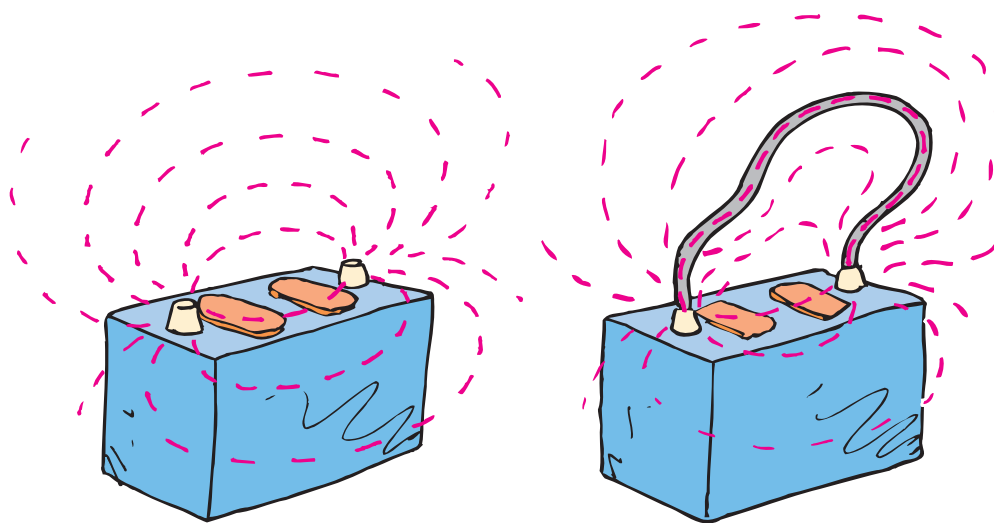

**FIGURE 34.13** ▲

The electric field lines between the terminals of a battery are directed through a conductor, which joins the terminals.

**Caution:** Don't short out the terminals of a battery as shown in Figure 34.13. If you touch both terminals with a metal wrench, for instance, you can create a spark that can ignite hydrogen gas in the battery and send pieces of battery and acid flying.



## 34.9 The Speed of Electrons in a Circuit

► **Teaching Tip** Use the following analogy to help explain how DC current travels in a circuit: Ask the class to suppose that there is a long column of marchers at the front of the room, all standing at rest close together. Walk to the end of this imaginary column and give a gentle shove to the “last person.” Ask the class to imagine the resulting impulse traveling along the line until the first marcher is jostled against the wall. Then ask if this is a good analogy for how electricity travels in a wire. The answer is no. It is a good analogy for how sound travels, but not electricity. Stress how slowly the disturbance traveled, and how slowly sound travels compared to light or electricity. Again call attention to the column of marchers and walk to the far end and call out, “Forward march!” As soon as the command reaches each person, each one steps forward. The marcher at the beginning of the column, except for the slight time required for the sound to get to her, steps immediately. State that this is an analogy for electricity. Except for the brief time it takes for the electric *field* set up at the power source to travel through the wire (and the field moves at nearly the speed of light) electrons at the far end of the circuit respond immediately. State that the speed at which the command “forward march” traveled is altogether different from how fast each marcher moved upon receiving that command—and that the velocity of the electric signal (nearly the speed of light) is quite a bit different than the drift velocity of electrons (typically 0.01 cm/s) in a circuit.



**Ask** When turning the key to start a car, electrons migrate from the negative battery terminal through the electric network to the starter motor and back to the positive battery terminal. Estimate the time required for electrons to leave the negative terminal, go through the circuit, and return to the battery. Less than a millisecond? Less than a second? About a second or two? Or about an hour? *Class interest should be high when you announce the last answer!*

**FIGURE 34.14** ▶

The solid lines depict a random path of an electron bouncing off atoms in a conductor. The dashed lines show an exaggerated view of how this path changes when an electric field is applied. The electron drifts toward the right with an average speed less than a snail's pace.

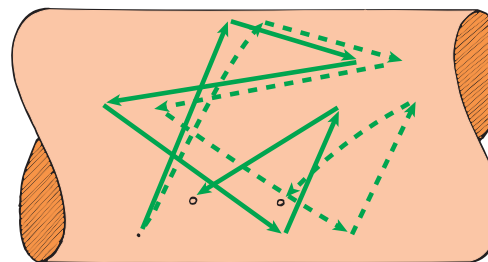

Conduction electrons are accelerated by the field. Before the electrons gain appreciable speed, they “bump into” the anchored metallic ions in their paths and transfer some of their kinetic energy to them. This is why current-carrying wires become hot. ✓ **In a current-carrying wire, collisions interrupt the motion of the electrons so that their actual drift speed, or net speed through the wire due to the field, is extremely low.** In a typical DC circuit, in the electric system of an automobile for example, electrons have a net average drift speed of about 0.01 cm/s. At this rate, it would take about three hours for an electron to travel through 1 meter of wire.

In an AC circuit, the conduction electrons don't make any net progress in any direction. In a single cycle they drift a tiny fraction of a centimeter in one direction, and then the same tiny distance in the opposite direction. Hence they oscillate rhythmically to and fro about relatively fixed positions. When you talk to your friend on a conventional telephone, it is the *pattern* of oscillating motion that is carried across town at nearly the speed of light. The electrons already in the wires vibrate to the rhythm of the traveling pattern. (In a cell phone, as you'll see in Chapter 37, the electrons dance to the rhythmic pattern of electromagnetic waves in the air.)

**CONCEPT CHECK:** Why is the drift speed of electrons in a current-carrying wire extremely low?

**CONCEPT CHECK:** In a current-carrying wire, collisions interrupt the motion of the electrons so that their actual drift speed, or net speed through the wire due to the field, is extremely low.

### Teaching Resources

- Reading and Study Workbook
- PresentationEXPRESS
- Interactive Textbook

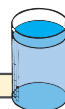

### Link to ELECTROCHEMISTRY

**Electrolysis** Electrochemistry is about electrical energy and chemical change. Molecules in a liquid can be broken apart and separated by the action of electric current. This is *electrolysis*. A common example is passing an electric current through water, separating water molecules into their hydrogen and oxygen components. This common process is also at work when a car battery is recharged. Electrolysis is also used to produce metals from ores. Aluminum is a familiar metal produced by electrolysis. Aluminum is common today, but before the advent of its production by electrolysis in 1886, aluminum was much more expensive than silver or gold!

## 34.10 The Source of Electrons in a Circuit

In a hardware store you can buy a water hose that is empty of water. But you can't buy a piece of wire, an "electron pipe," that is empty of electrons. ✓ **The source of electrons in a circuit is the conducting circuit material itself.** Some people think that the electric outlets in the walls of their homes are a source of electrons. They think that electrons flow from the power utility through the power lines and into the wall outlets of their homes. This is not true. The outlets in homes are AC. Electrons do not travel appreciable distances through a wire in an AC circuit. Instead, they vibrate to and fro about relatively fixed positions.

When you plug a lamp into an AC outlet, *energy* flows from the outlet into the lamp, not electrons. Energy is carried by the electric field and causes a vibratory motion of the electrons that already exist in the lamp filament. If 120 volts AC are impressed on a lamp, then an average of 120 joules of energy are dissipated by each coulomb of charge that is made to vibrate. Most of this electrical energy appears as heat, while some of it takes the form of light. Power utilities do not sell electrons. They sell *energy*. You supply the electrons.

Thus, when you are jolted by an AC electric shock, the electrons making up the current in your body originate in your body. Electrons do not come out of the wire and through your body and into the ground; energy does. The energy simply causes free electrons in your body to vibrate in unison. Small vibrations tingle; large vibrations can be fatal.

**CONCEPT CHECK:** What is the source of electrons in a circuit?

## 34.11 Electric Power

Unless it is in a superconductor, a charge moving in a circuit expends energy. This may result in heating the circuit or in turning a motor. **Electric power** is the rate at which electrical energy is converted into another form such as mechanical energy, heat, or light. ✓ **Electric power is equal to the product of current and voltage.**<sup>34.11.1</sup>

$$\text{electric power} = \text{current} \times \text{voltage}$$

If the voltage is expressed in volts and the current in amperes, then the power is expressed in watts. So, in units form,

$$1 \text{ watt} = (1 \text{ ampere}) \times (1 \text{ volt})$$

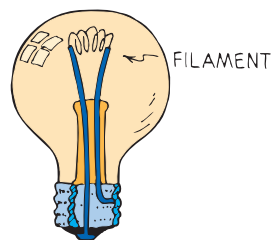

**FIGURE 34.15** ▲ The conduction electrons that surge to and fro in the filament of the lamp do not come from the voltage source. They are in the filament to begin with. The voltage source simply provides them with surges of energy.

## 34.10 The Source of Electrons in a Circuit

### Common Misconception

A voltage or power source supplies electrons to a circuit to which it is connected.

**FACT** The voltage or power source supplies only energy, not electrons.

► **Teaching Tip** Ask students to estimate the number of electrons pumped by the local power plant into the homes and industries locally in the past year. [Zero] Stress the idea that power plants sell not electrons, but energy. Discuss the origin of electrons in electric circuits.

**CONCEPT CHECK:** The source of electrons in a circuit is the conducting material itself.

### Teaching Resources

- Reading and Study Workbook
- PresentationEXPRESS
- Interactive Textbook

## 34.11 Electric Power

### Key Term

electric power

► **Teaching Tip** Distinguish between energy and power. Electric power is usually expressed in kilowatts, and electrical energy in kilowatt-hours. Use an actual electricity bill to make your point. Note that a kilowatt-hour is  $1000 \text{ J/s} \times 3600 \text{ s}$ , or 3600 kJ.

Solid-state lighting may soon make conventional lightbulbs obsolete. Watch for the progression of LEDs from flashlights to automobile headlights.



► **Teaching Tip** A 100-W bulb doesn't *have* 100 watts; it *uses* 100 watts when lit.

$$1\text{W} = \frac{1\text{J}}{1\text{C}} \times \frac{1\text{C}}{1\text{s}} = \frac{1\text{J}}{1\text{s}}$$



**FIGURE 34.16** ▲ The power and voltage on the lightbulb read "60 W, 120 V." You can calculate the current that would flow through the bulb as follows:  
 $I = P/V = (60\text{ W})/(120\text{ V}) = 0.5\text{ A}$ .

If a lamp rated at 120 watts operates on a 120-volt line, you can see that it will draw a current of 1 ampere, since  $120\text{ watts} = (1\text{ ampere}) \times (120\text{ volts})$ . A 60-watt lamp draws 0.5 ampere on a 120-volt line. This relationship becomes a practical matter when you wish to know the cost of electrical energy, which varies from 1 cent to 10 cents per kilowatt-hour depending on locality.

A *kilowatt* is 1000 watts, and a *kilowatt-hour* represents the amount of energy consumed in 1 hour at the rate of 1 kilowatt.<sup>34.11.2</sup> Therefore, in a locality where electrical energy costs 10 cents per kilowatt-hour, a 100-watt electric lightbulb can be run for 10 hours at a cost of 10 cents, or a cent for each hour. A toaster or iron, which draws more current and therefore more power, costs several times as much to operate for the same time.

**CONCEPT:** How can you express electric power in terms of  
**CHECK:** current and voltage?

### think!

How much power is used by a calculator that operates on 8 volts and 0.1 ampere? If it is used for one hour, how much energy does it use?

**Answer:** 34.11.1

Will a 1200-watt hair dryer operate on a 120-volt line if the current is limited to 15 amperes by a safety fuse? Can two hair dryers operate on this line?

**Answer:** 34.11.2

**CONCEPT:** Electric power is  
**CHECK:** equal to the product of current and voltage.

#### Teaching Resources

- Reading and Study Workbook
- Concept-Development Practice Book 34-2
- Problem-Solving Exercises in Physics 17-2, 17-3
- PresentationEXPRESS
- Interactive Textbook

# 34 REVIEW

Go Online  
PHSchool.com

For: Self-Assessment

Visit: PHSchool.com

Web Code: csa - 3400

# 34 REVIEW

## Teaching Resources

- TeacherEXPRESS
- Virtual Physics Lab 31
- Conceptual Physics Alive!  
DVDs *Electric Current*

## Concept Summary

- When the ends of an electric conductor are at different electric potentials, charge flows from one end to the other.
- A current-carrying wire has a net electric charge of zero.
- Voltage sources such as batteries and generators supply energy that allows charges to move steadily.
- The resistance of a wire depends on the conductivity of the material used in the wire and also on the thickness and length of the wire.
- Ohm's law states that the current in a circuit is directly proportional to the voltage impressed across the circuit and is inversely proportional to the resistance of the circuit.
- The damaging effects of shock are the result of current passing through the body.
- Electric current may be AC or DC.
- With an AC–DC converter, you can operate a battery-run device on AC instead of batteries.
- In a current-carrying wire, collisions interrupt the motion of the electrons so that their actual *drift speed*, or *net speed*, through the wire due to the field is extremely low.
- The source of electrons in a circuit is the conducting circuit material itself.
- Electric power is equal to the product of current and voltage.

## Key Terms

- |                                      |                                     |
|--------------------------------------|-------------------------------------|
| <b>potential difference</b> (p. 681) | <b>superconductivity</b> (p. 684)   |
| <b>electric current</b> (p. 682)     | <b>ohm</b> (p. 684)                 |
| <b>ampere</b> (p. 682)               | <b>Ohm's law</b> (p. 685)           |
| <b>voltage source</b> (p. 683)       | <b>direct current</b> (p. 688)      |
| <b>electric resistance</b> (p. 684)  | <b>alternating current</b> (p. 688) |
|                                      | <b>diode</b> (p. 690)               |
|                                      | <b>electric power</b> (p. 693)      |

## think! Answers

$$34.5 \quad \text{Current} = \frac{\text{voltage}}{\text{resistance}} = \frac{50 \text{ V}}{100 \Omega} = 0.5 \text{ A}$$

$$34.6.1 \quad \text{Current} = \frac{\text{voltage}}{\text{resistance}} = \frac{12 \text{ V}}{100,000 \Omega} = 0.00012 \text{ A (quite harmless)}$$

$$34.6.2 \quad \text{You would draw } \frac{24 \text{ V}}{1000 \Omega}, \text{ or } 0.024 \text{ A, a dangerous amount of current!}$$

$$34.11.1 \quad \text{Power} = \text{current} \times \text{voltage} = (0.1 \text{ A}) \times (8 \text{ V}) = 0.8 \text{ W. Energy} = \text{power} \times \text{time} = (0.8 \text{ W}) \times (1 \text{ h}) = 0.8 \text{ watt-hour, or } 0.0008 \text{ kilowatt-hour.}$$

34.11.2 One 1200-W hair dryer can be operated because the circuit can provide  $(15 \text{ A}) \times (120 \text{ V}) = 1800 \text{ W}$ . But there is inadequate power to operate two hair dryers of combined power 2400 W. In terms of current,  $(1200 \text{ W}) / (120 \text{ V}) = 10 \text{ A}$ ; so the hair dryer will operate when connected to the circuit. But two hair dryers will require 20 A and will blow the 15-A fuse.



## Check Concepts .....

1. Temperature difference; voltage difference
2.  $PE/q$ ;  $\Delta PE/q$  between points
3. Pressure difference; potential difference
4. Flow of charge
5. Flow of 1 C per second
6. Electric "pressure,"  $PE/q$ , that produces electric current
7. 120
8. Through
9. Established across; only charge flows.
10. That which resists flow of charge (measured in ohms)
11. Greater in a long, thin wire
12. Current = voltage/resistance, or  $I = V/R$
13. Drops to half
14. Drops to half
15. Lowers skin resistance
16. Negligible potential difference across the body
17. Serves as a ground connection
18. DC—current flows in one direction; AC—direction alternates; DC is produced by a battery, AC by a generator.
19. Capacitor
20. Diode—converts AC to DC; capacitor smooths current.

## Check Concepts .....

### Section 34.1

1. What condition is necessary for the flow of heat? What analogous condition is necessary for the flow of charge?
2. What is meant by the term *potential*? What is meant by *potential difference*?
3. What condition is necessary for the sustained flow of water in a pipe? What analogous condition is necessary for the sustained flow of charge in a wire?

### Section 34.2

4. What is electric current?
5. What is an ampere?

### Section 34.3

6. What is voltage?
7. How many joules per coulomb are given to charges that flow in a 120-volt circuit?
8. Does charge flow through a circuit or into a circuit?
9. Does voltage flow through a circuit, or is voltage established across a circuit?

### Section 34.4

10. What is electric resistance?
11. Is electric resistance greater in a short fat wire or a long thin wire?

### Section 34.5

12. What is Ohm's law?

13. If the resistance of a circuit remains constant while the voltage across the circuit decreases to half its former value, what change occurs in the current?
14. If the voltage impressed across a circuit is constant but the resistance doubles, what change occurs in the current?

### Section 34.6

15. How does wetness affect the resistance of your body?
16. Why is it that a bird can perch without harm on a high-voltage wire?



17. What is the function of the third prong in a household electric plug?

### Section 34.7

18. Distinguish between DC and AC. Which is produced by a battery and which is usually produced by a generator?

### Section 34.8

19. A diode converts AC to pulsed DC. What electric device smooths the pulsed DC to a smoother DC?
20. What are the roles of a diode and a capacitor in an AC-DC converter?

### Section 34.9

21. What is a typical “drift” speed of electrons that make up a current in a typical DC circuit? In a typical AC circuit?

### Section 34.10

22. From where do the electrons originate that flow in a typical electric circuit?

### Section 34.11

23. What is power?
24. Which of these is a unit of power and which is a unit of electrical energy: a watt, a kilowatt, and a kilowatt-hour?
25. How many amperes flow through a 60-watt bulb when 120 volts are impressed across it?

## Think and Rank . . . . .

Rank each of the following sets of scenarios in order of the quantity or property involved. List them from left to right. If scenarios have equal rankings, separate them with an equal sign. (e.g.,  $A = B$ )

26. Rank the circuits below according to the brightness of the bulbs, from brightest to dimmest.

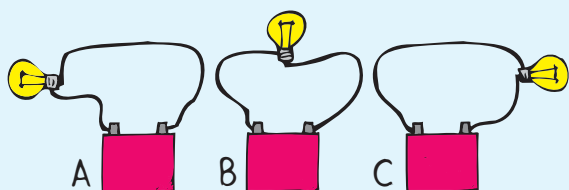

27. The bulbs shown below are identical. An ammeter is placed in different branches, as shown. Rank the current readings in the ammeter from greatest to least.

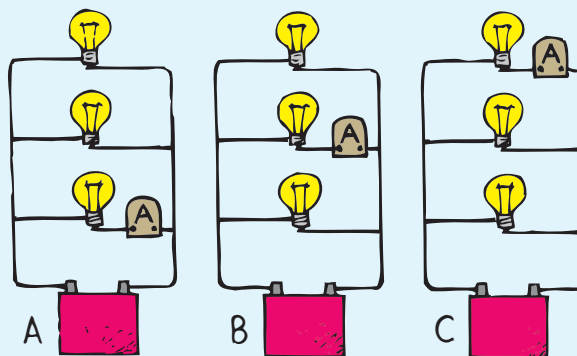

28. All bulbs are identical in the circuits shown below. An ammeter is connected next to the battery as shown. Rank the current readings in the ammeter, from greatest to least.

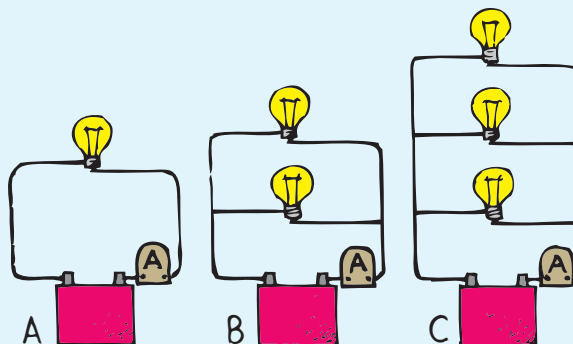

21. DC—less than 1 cm/s; AC—zero
22. From the conductors themselves
23.  $P = \text{energy/time}$ , rate of doing work
24. Power—watt, kilowatt; energy—kilowatt-hour
25. From  $P = IV$ ,  
 $60 \text{ W} = I \times 120 \text{ V}$ ;  $I = 0.5 \text{ A}$

## Think and Rank . . . . .

26.  $A = B = C$
27.  $A = B = C$
28. C, B, A

29. A, B, C  
 30. a. C, B, A  
 b.  $A = B = C$

### Plug and Chug .....

31.  $I = q/t = (10 \text{ C})/(5 \text{ s}) = 2 \text{ A}$   
 32.  $I = (35 \text{ C})/(10^{-3} \text{ s}) = 35,000 \text{ A}$   
 33.  $I = V/R = (120 \text{ V})/(14 \Omega) = 8.6 \text{ A}$   
 34.  $I = V/R = (240 \text{ V})/(60 \Omega) = 4 \text{ A}$   
 35.  $I = V/R = (9 \text{ V})/(90 \Omega) = 0.1 \text{ A}$   
 36.  $I = V/R = (6 \text{ V})/(1200 \Omega) = 0.005 \text{ A}$   
 37.  $P = IV = (1.20 \text{ A})(120 \text{ V}) = 144 \text{ W}$

### Think and Explain .....

38. No; it simply states a typical speed of electrons within the material.  
 39. Different quantities; the potential difference (or voltage) causes a flow of charge, which is the current.  
 40. Increased current results in the bulb glowing brighter.  
 41. Thick wires have less electrical resistance and will carry greater amounts of current without overheating.  
 42. The amount of energy converted to thermal energy depends on the resistance of the wire and the amount of current flowing in it. An electric heater draws a lot of current, so if the connecting wire has a high resistance, much energy will be wasted in heating the wire.

# 34 ASSESS *(continued)*

29. In each of the circuits shown below, a voltmeter is connected across a bulb to measure the voltage drop across it. Rank the voltage readings from greatest to least.

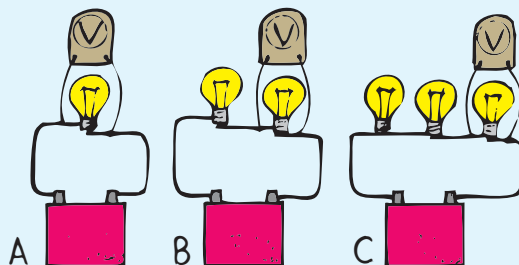

30. All bulbs are identical in the circuit shown to the right. The circuit consists of three parts: (A) the top branch with two bulbs; (B) the middle branch with one bulb; and (C) the battery.

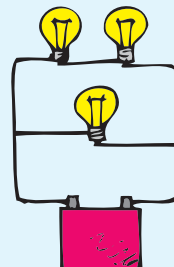

- a. Rank the current through A, B, and C, from greatest to least.  
 b. Rank the voltage across A, B, and C, from greatest to least.

### Plug and Chug .....

The key equations of the chapter are shown below in bold type.

$$\text{Ohm's law: } I = \frac{V}{R}$$

$$\text{Electric power: } P = IV$$

31. Calculate the current where 10 coulombs of charge pass a point in 5 seconds.  
 32. Calculate the current of a lightning bolt that delivers a charge of 35 coulombs to the ground in a time of 1/1000 second.  
 33. Calculate the current in a toaster that has a heating element of 14 ohms when connected to a 120-V outlet.  
 34. Calculate the current in the coiled heating element of a 240-V stove. The resistance of the element is 60 ohms at its operating temperature.  
 35. Electric socks, popular in cold weather, have a 90-ohm heating element that is powered by a 9-volt battery. How much current warms your feet?  
 36. How much current moves through your fingers (resistance: 1200 ohms) if you touch them to the terminals of a 6-volt battery?  
 37. Calculate the power supplied to an electric blanket that carries 1.20 A when connected to a 120-V outlet.

### Think and Explain .....

38. Is this label on a household product cause for concern? "Caution: This product contains tiny electrically charged particles moving at speeds in excess of 10,000,000 kilometers per hour."

39. Do an *ampere* and a *volt* measure the same thing, or different things? What are those things, and which is a flow and which is the cause of the flow?
40. What happens to the brightness of light emitted by a light bulb when the current in it increases?
41. In terms of heating, why are thick wires rather than thin wires used to carry large currents?
42. Why is it important that the resistance of an extension cord be small when it is used to power an electric heater?
43. Why will an electric drill operating on a very long extension cord not rotate as fast as one operated on a short cord?
44. Your tutor tells you that an ampere and a volt really measure the same thing, and the different terms only serve to make a simple concept seem confusing. Why should you consider getting a different tutor?
45. Does more current flow out of a battery than into it? Does more current flow into a lightbulb than out of it? Explain.
46. A simple lie detector consists of an electric circuit, one part of which is part of your body. A sensitive meter shows the current that flows when a small voltage is applied. How does this technique indicate that a person is lying? (And when does this technique not indicate when someone is lying?)

47. Only a small fraction of the electric energy fed into a common lightbulb is transformed into light. What happens to the rest?
48. Will a lamp with a thick filament draw more current or less current than a lamp with a thin filament made of the same material?
49. A 1-mile-long copper wire has a resistance of 10 ohms. What will be its new resistance when it is shortened by (a) cutting it in half or by (b) doubling it over and using it as if it were one wire of half the length but twice the cross-sectional area?



50. Will the current in a lightbulb connected to 220 V be more or less than when the bulb is connected to 110 V? How much?
51. Which will do more damage—plugging a 110-V toaster into a 220-V circuit or plugging a 220-V toaster into a 110-V circuit? Explain.
52. If a current of one- or two-tenths of an ampere were to flow into one of your hands and out the other, you would probably be electrocuted. But if the same current were to flow into your hand and out the elbow above the same hand, you could survive, even though the current might be large enough to burn your flesh. Explain.
43. The longer an extension cord, the greater its resistance, and the more energy is dissipated in it, with less available for the electric drill.
44. The tutor is wrong. Ampere measures current; volt measures electric potential (electric pressure). Volts produce amperes in a conductor.
45. No, no. Current flows *through* a device, just as water flows through a pipe.
46. The lie detector relies on the likelihood that resistivity of your body changes when you are lying. It is not effective for a person able to lie with no emotional change and no change in perspiration.
47. Dissipated as heat (as much as 95% for an incandescent bulb).
48. Thick filament has less resistance and draws more current than a thin filament connected across the same potential difference.
49. a. Resistance is halved to 5 ohms when wire is cut in half.  
b. Resistance is halved again when cross-sectional area is doubled, so the new resistance is 2.5 ohms.
50. More; for the same resistance, current will double when the voltage is doubled.
51. Connecting a 110-V toaster to a 220-V circuit produces overheating and probable damage. The other way around is unlikely to do any damage.
52. Through hands means current passes through your chest and maybe heart; less damage from hand to elbow.



53. Current remains the same in both cases.
54. Twice per cycle so 120 times per second
55. Drift speed of conduction electrons is slow, but the signal travels at about the speed of light.
56. a. volt  
b. ampere  
c. joule
57. More current flows in the 60-W bulb, which means the resistance of the filament is less. [From  $P = IV = V^2/R$ ,  $R = V^2/P = (120 \text{ V})^2/(60 \text{ W}) = 240 \Omega$ ; for the 40-W lamp,  $R = (120 \text{ V})^2/(40 \text{ W}) = 360 \Omega$ .]
58. Less resistance in 50-W lamp.

### Think and Solve .....

59.  $I = q/t = (100 \text{ C})/(0.05 \text{ s}) = 2000 \text{ A}$
60.  $q = I \times t = 0.0001 \text{ A} \times 60 \text{ s} = 0.006 \text{ C}$
61.  $V = I \times R = (2 \text{ A})(8 \Omega) = 16 \text{ V}$
62. From  $P = I \times V$ ,  $I = P/V = (1200 \text{ W})/(120 \text{ V}) = 10 \text{ A}$ ;  $R = V/I = (120 \text{ V})/(10 \text{ A}) = 12 \Omega$
63. From  $I = V/R$ , multiplication by  $R$  gives  $IR = V$ . Division by  $I$  gives  $R = V/I$ .
64.  $R = V/I = (120 \text{ V})/(20 \text{ A}) = 6 \Omega$
65. Ohm's law can be stated as  $V = IR$ . Then  $P = IV = I(IR) = I^2R$ .
66. a.  $I = V/R = (120 \text{ V})/(12 \Omega) = 10 \text{ A}$   
b.  $P = IV = (10 \text{ A})(120 \text{ V}) = 1200 \text{ W}$
67.  $R = V/I = (3.0 \text{ V})/(0.4 \text{ A}) = 7.5 \Omega$
68. a. From  $P = IV$ ,  $I = P/V = (60 \text{ W})/(120 \text{ V}) = 0.50 \text{ A}$   
b. From  $I = V/R$ ,  $R = V/I = (120 \text{ V})/(0.50 \text{ A}) = 240 \Omega$

# 34 ASSESS (continued)

53. What is the effect on current if both the voltage and the resistance are doubled? If both are halved?
54. In 60-Hz alternating current, how many times per second does an electron change its direction? (Don't say 60!)
55. If electrons flow very slowly through a circuit, why doesn't it take a noticeably long time for a lamp to glow when you turn on a distant switch?
56. What unit is represented by (a) joule per coulomb, (b) coulomb per second, and (c) watt-second?
57. Two lightbulbs designed for 120-V use are rated at 40 W and 60 W. Which lightbulb has the greater filament resistance? Why?
58. A car's headlights dissipate 40 W on low beam and 50 W on high beam. Is there more or less resistance in the high-beam filament?
62. Use the relationship power = current  $\times$  voltage to find out how much current is drawn by a 1200-watt hair dryer when it operates on 120 volts. Then use Ohm's law to find the resistance of the hair dryer.
63. The current driven by voltage  $V$  in a circuit of resistance  $R$  is given by Ohm's law,  $I = V/R$ . Show that the resistance of a circuit carrying current  $I$  and driven by voltage  $V$  is given by the equation  $R = V/I$ .
64. Use the equation just derived and show that when a device in a 120-V circuit draws a current of 20 A, its resistance is 6  $\Omega$ .
65. The power of an electric circuit is given by the equation  $P = IV$ . Use Ohm's law to express  $V$  and show that power can be expressed by the equation  $P = I^2R$ .
66. An electric heater has a heating element of resistance 12  $\Omega$ . It is plugged into a wall socket that provides 120 V.  
a. What is the current through the heater?  
b. What is the power "consumption" of the heater?

### Think and Solve .....

59. How much current, in amperes, is in a lightning stroke that lasts 0.05 second and transfers 100 coulombs?
60. How much charge flows in a pocket calculator each minute when the current is 0.0001 ampere?
61. How much voltage is required to make 2 amperes flow through a resistance of 8 ohms?
67. Calculate the resistance of the filament in a lightbulb that carries 0.4 A when 3.0 V is impressed across it.
68. A lightbulb is marked "120 V, 60 W."  
a. What current flows through the filament when the bulb is turned on?  
b. Show that the electrical resistance of the lightbulb filament is 240  $\Omega$ .

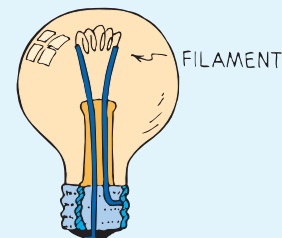

69. A microwave oven is marked “120 V, 1100 W.”
- How much current does the oven draw?
  - To heat 380 g of 20°C water to 86°C, show that you should set the timer for at least 95 s.

70. A typical car headlight may put out 50 watts at 12 volts.
- Show that 4.2 A is drawn by the headlight.
  - How many electrons pass through the bulb filament each second?

71. Suppose that an ammeter inserted in series in a toaster circuit shows that the current is 5.0 amps when the toaster is plugged into a 120-volt circuit. Show that the energy dissipated by the toaster in 40 seconds is 24,000 joules.

72. The wattage marked on a lightbulb is not an inherent property of the bulb but depends on the amount of voltage to which it is connected, usually 110 V or 120 V.
- Calculate the current through a 40-W bulb connected to 120 V.
  - Calculate the current through the same bulb when it is connected to 60 V.

73. The resistance of a certain wire is 10 ohms.
- What would the resistance of the same wire be if it were twice as long?
  - If it had twice the diameter?

74. Calculate the power dissipated in a toaster that has a resistance of 14 ohms and is plugged into a 120-V outlet.

75. Calculate the yearly cost of running a 5-W electric clock continuously in a location where electricity costs 10 cents per kW·h.

## Activity .....

76. Batteries are made up of electric cells, which are composed of two unlike pieces of metal separated by a conducting solution. A simple 1.5-volt cell, equivalent to a flashlight cell, can be made by placing a strip of copper and a strip of zinc in a moist vegetable or piece of fruit, as shown in the figure. A lemon or banana works well. Hold the ends of the strips close together but not touching, and place the ends on your tongue. The slight tingle you feel and the metallic taste you experience result from a small electric current that flows through the cell when your moist tongue closes the circuit. Try this and compare the results for different metals and different fruits and vegetables.

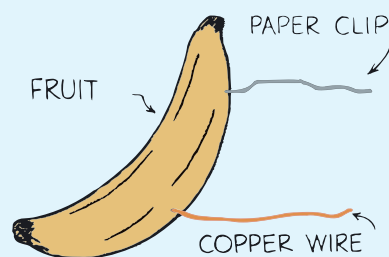

More Problem-Solving Practice  
Appendix F

69. a. From  $P = IV$ ,  $I = P/V = (1100 \text{ W})/(120 \text{ V}) = 9.2 \text{ A}$ .
- b. The energy needed to heat the water is  $Q = mc\Delta T = (380 \text{ g})(4.186 \text{ J/g}^\circ\text{C})(86^\circ\text{C} - 20^\circ\text{C}) = 1.05 \times 10^5 \text{ J}$ . From  $P = \text{energy/time}$ ,  $t = Q/P = (1.05 \times 10^5 \text{ J})/(1100 \text{ J/s}) = 95 \text{ s}$  if all energy goes into heating the water.
70. a. From  $P = IV$ ,  $I = P/V = (50 \text{ W})/(12 \text{ V}) = 4.2 \text{ A}$ .
- b.  $4.2 \text{ A} = 4.2 \text{ C/s} \times (1 \text{ electron}/1.6 \times 10^{-19} \text{ C}) = 2.6 \times 10^{19}$  electrons per second
71.  $P = IV = (5.0 \text{ A})(120 \text{ V}) = 600 \text{ W}$ . From  $P = \text{energy/time}$ ,  $\text{energy} = Pt = (600 \text{ J/s})(40 \text{ s}) = 24,000 \text{ J}$ .
72. a. From  $P = I \times V$ ,  $I = P/V = (40 \text{ W})/(120 \text{ V}) = 0.33 \text{ A}$ .
- b. At half the voltage there will be half the current, or 0.17 A.
73. 20  $\Omega$ ; 2.5  $\Omega$ , because twice the diameter gives four times the cross sectional area and one-fourth the resistance
74.  $P = I \times V = (V/R) \times V = V^2/R = (120 \text{ V})^2/(14 \Omega) = 1030 \text{ W}$
75.  $5 \text{ W} \times \$0.10/\text{kWh} \times (1 \text{ kW})/(1000 \text{ W}) \times (24 \text{ h})/(1 \text{ day}) \times (365 \text{ day})/(1 \text{ yr}) = \$4.38/\text{yr}$

## Activity .....

76. All moist objects will work to varying degrees.

## Teaching Resources

- Computer Test Bank
- Chapter and Unit Tests