

EFFICIENCY THAT TURNS INTO GREAT SAVINGS



ELECTRIC MOTOR PRICE LIST



OCTOBER

2019

WEG MOTOR SCAN REDUCE MAINTENANCE COSTS!



The performance monitoring industry will never be the same again.

WEG Motor Scan is a performance monitoring solution for electric motors. The motor operating data is extracted and sent to the cloud, making preventive maintenance easy and avoiding the risk of unplanned downtime.

MOTOR SCAN SENSOR LIST PRICE EACH.	<100	≥100	≥500	≥1000
	R 6,000	R 5,700	R 5,400	R 5,100
MOTOR SCAN SUBSCRIPTION ACCESS TO IOT WEB PORTAL	YEAR 1	YEAR 2 AND ON	*TCO CUSTOMERS	
	Free	R1,500 per sensor/year	Free	

Standard customer discount applies to these list prices.

*Contact your sales representative for details

www.zestweg.com/wegmotorscan





CONTENTS

Branch Contact Details	04
Three Phase Cast Iron Motor IE3	07
Three Phase Cast Iron Motor IE1	17
Three Phase Aluminium Motor IE1	26
Single Phase Aluminium Motor IE1	28
WEG Electronically Commutated Motor IE5	29
Three Phase Cast Iron WWash Motor IE3	34
Flame Proof Motor IE2	37
Brake Motor IE3	40
Invicta Vibrator Motors	41
Optional Features	44
Spare Parts	45
Dimensions for W22 Foot Mount	46
Dimensions for Pad Mount	50
Dimensions for Flange Mount	52
Dimensions for W22 Fans IE1 & IE3	53
Slide Rails	54
High Voltage Motors	55
Technical Information	56
Formulae	58
Global Product Certification	59
Downloads & Tools	60
Group Company Contact Details	61
National Distributor Contact Details	62
African Distributor Contact Details	63

BRANCH CONTACT DETAILS

HEAD OFFICE

JOHANNESBURG

47 Galaxy Avenue, Linbro Business Park
Private Bag X10011, Sandton 2146
Gps co-ordinates S 26° 4' 10.92" E 28° 6' 45.88"
Tel +27 (0) 11 723 6000

LV MOTOR SALES
lvmotorsales@zestweg.com

HV MOTORS & PROJECTS
zpq@zestweg.com

DRIVES & AUTOMATION
drivesales@zestweg.com

DRIVES PROJECTS
projects@zestweg.com

SWITCHGEAR
switchgearsales@zestweg.com

GENERATOR SET DIVISION
gensets@zestweg.com

MOTOR TECHNICAL SUPPORT
ts-motors@zestweg.com

AFTER HOURS

MOTORS

+27 (0) 83 642 4930 +27 (0) 71 475 1457

DRIVES & AUTOMATION

+27 (0) 82 887 2615

GENSETS

+27 (0) 83 326 6862

SWITCHGEAR

+27 (0) 72 628 8767

BRANCHES

CAPE TOWN

9 Omuramba Rd Marconi Beam
Monague Gardens, Milnerton
P.O Box 36582, Chempet 7442
GPS: S 33° 52' 42.94" E 18° 30' 39.54"
Tel +27 (0) 21 551 2710
Fax +27 (0) 86 417 8153
capetown@zestweg.com

BRANCH MANAGER Marthinus Greeff
+27 (0) 83 326 6870
AFTER HOURS
DRIVES & AUTOMATION
+27 (0) 79 830 0520
MOTORS
+27 (0) 73 265 0875

DURBAN

51 Island Circle, Riverhorse Valley Business Estate
P O Box 20667 Durban North 4016
GPS : S 29° 46' 5.53" E 31° 0' 21.04"
Tel: +27 (0) 31 569 7260
Fax: +27 (0) 86 417 8424
durban@zestweg.com

BRANCH MANAGER Glen Ward
+27 (0) 82 883 4070
AFTER HOURS
DRIVES & AUTOMATION
+27 (0) 76 981 0035
MOTORS
+27 (0) 82 570 0876

MIDDELBURG

6 Wicht Street, Vaalbank, Middelburg
GPS: S 25° 47' 7.70" E 29° 28' 42.33"
Tel: +27 (0) 13 246 2849
Fax: +27 (0) 86 417 8404
mpumalanga@zestweg.com

BRANCH MANAGER Fritz Hoogenboezem
+27 (0) 82 802 4805
AFTER HOURS
DRIVES & AUTOMATION
+27 (0) 82 885 2307

PORT ELIZABETH

1 Millennium Road, Old Showgrounds, North End
P.O. Box 2565, North End 6056
GPS: S 33° 55' 70.7" E 25° 36' 19.6"
Tel: +27 (0) 41 486 1262
Fax: +27 (0) 86 417 8358
portelizabeth@zestweg.com

BRANCH MANAGER Karen Meyer
+27 (0) 82 806 2444
AFTER HOURS
DRIVES & AUTOMATION & MOTORS
+27 (0) 82 677 5491



RICHARDS BAY

100 Alumina Allee

GPS: 28°45'27.414"S 32°1'30.586"E

Tel: +27 (0) 35 751 1607

Fax: +27 (0) 86 417 8296

richardsbay@zestweg.com

BRANCH MANAGER AFTER HOURS

Jacky Almond

+27 (0) 76 431 3374

DRIVES & AUTOMATION & MOTORS

+27 (0) 82 802 1948

RUSTENBURG

6 Kgwebo Road, Mabe Business Park

Old Pretoria Road

P O Box 649, Rustenburg 0300

GPS: S 25° 41' 14.11" E 27° 15' 38.78"

Tel: +27 (0) 14 594 0450

Fax: +27 (0) 86 417 8155

rustenburg@zestweg.com

BRANCH MANAGER AFTER HOURS

Leon Byleveldt

+27 (0) 78 804 0228

DRIVES & AUTOMATION & MOTORS

+27 (0) 82 881 1549

+27 (0) 72 611 6932

TRICHARDT

3 Schabort Street, Trichardt

P O Box 1626, Secunda 2302

GPS: S 26° 29' 28.08" E 29° 13' 15.64"

Tel: +27 (0) 17 638 1571

Fax: +27 (0) 86 417 8336

trichardt@zestweg.com

BRANCH MANAGER AFTER HOURS

Robbie Kuhn

+27 (0) 82 803 5580

DRIVES & AUTOMATION & MOTORS

+27 (0) 82 803 5580

+27 (0) 17 638 1571

MOTOR CHECKLIST

Minimum information required for an accurate quotation or purchase order.

Motor Characteristics	Selection Options/Examples (√)					
Installed Power (kW/ HP):	0.12kW to 500kW					
Poles:	2 Pole	4 Pole	6 Pole	8 Pole	Other	
Supply Voltage (V):	220/400V	400/690V		525/550V	550/950V	Other
Phase:	Single Phase			Three Phase		
Frequency (Hz):	50 Hz		60Hz		Other	
Frame Size:	SABS			NEMA		
Mounting:	B3 (Foot)	B5 (Flange)	B35 (Foot/ Flange)	B14S (Flange)	B14L (Flange)	Other
T-Box Position (Viewed Drive End):	Right Hand Side		Left Hand Side		Top	
Efficiency:	IE1		IE3		Other	
Starting Method:	DOL		VSD		Soft Starter	Other
Coupling Method:	Direct		Belts & Pulleys		Other	
Frame Material:	Cast Iron			Aluminium		
Ingress Protection:	IP55			IP66		
Area Classification:	Safe	Zone 1 (Flame Proof)		Zone 2 (Non-Spark- ing)	Zone 21/22 (Dust Ignition Proof)	
Quantity required:	Number of units to be ordered					
Motor Model:	W22	W22X	W11	W21	Invicta Vibrator	Other
Motor Application:	General Purpose	WWash	Brake Motor	Two Speed	JUD/BLZ	Other
Load Application Details:	Pump	Fan	Conveyor	Crusher	Compressor	Other
Motor Design Specification:	If there is a specification, please submit					
Centrifugal Force:	(Vibrator Motors) 50kgf to 13000kgf					



THREE PHASE CAST IRON MOTOR

IE3 Top Premium Efficiency

W22



Minimum info required for orders and enquires.	
W22 IE3	
kW	
Speed	
Voltage	
Mounting	

Reduces your energy costs
5 Year Guarantee on W22 Range

IP66

Class H Insulation

Δ 220-240V or Y 380-415V 50Hz (63 to 100 frame)

Δ 380-415V or Y 660-690V 50Hz (112 to 355 frame)

Δ 460V – 60Hz (112 to 355 frame)

or

Δ 525-550V or Y 1000V - 50Hz (63 to 355 frame)

Suitable for VSD

Electrically Insulated non-drive end bearing via end shield (≥ 315 frame)

Thermistors 01/ phase (225 to 355 frame)

Please refer to the Optional Features and Parts section for information on Optional Features.

IE4 Available on request

Efficiency values are given according to IEC 60034-2-1, they are calculated according to indirect method with stray load losses determined by measurement.

Paint finish RAL 6002

TEFC

All prices and values are subject to change without prior notice.

To obtain guaranteed values, please contact your nearest sales office.

Please check page 6 for the minimum requirements for accurate quotations and purchase orders.

THREE PHASE CAST IRON MOTOR IE3 TOP PREMIUM EFFICIENCY W22
Class H Insulation
 380V / 400V / 415V or 525V / 550V / 1000V **IP66**

2 Pole					Excl. VAT	
kW	r/min	Frame Size	Shaft (mm)	Weight (kg)	Foot Mounted	Flange Mounted
0.18	2860	63	11	7.6	R 2,602	R 3,297
0.25	2805	63	11	7.8	R 2,698	R 3,369
0.37	2820	71	14	10.1	R 3,266	R 4,078
0.55	2770	71	14	11	R 3,284	R 4,096
0.75	2850	80	19	14	R 4,253	R 5,330
1.1	2830	80	19	14.8	R 4,518	R 5,620
1.5	2875	90S	24	21.5	R 4,783	R 5,790
2.2	2865	90L	24	25	R 6,061	R 7,316
3	2910	100L	28	32.8	R 7,230	R 8,598
4	2900	112M	28	42.5	R 8,183	R 9,479
5.5	2940	132S	38	61	R 9,951	R 11,481
7.5	2935	132S	38	68.6	R 11,718	R 13,424
9.2	2935	132M	38	83.2	R 16,326	R 19,007
11	2950	160M	42	113	R 20,905	R 23,820
15	2945	160M	42	120	R 25,804	R 29,352
18.5	2945	160L	42	135	R 31,472	R 34,915
22	2950	180M	48	166	R 39,123	R 43,186
30	2965	200L	55	230	R 48,367	R 54,051
37	2960	200L	55	246	R 57,046	R 63,646
45	2960	225S/M	55	396	R 77,720	R 85,685
55	2965	250S/M	60	466	R 96,629	R 104,853
75	2965	250S/M	60	500	R 128,651	R 141,913
90	2975	280S/M	65	717	R 147,199	R 160,301
110	2975	280S/M	65	790	R 174,405	R 187,770
132	2980	315S/M	65	950	R 203,212	R 219,127
160	2980	315S/M	65	1079	R 232,209	R 253,602
185	2980	315S/M	70	1123	R 276,069	R 287,561
200	2975	315S/M	70	1200	R 286,238	R 302,167
220	2985	355M/L	90	1600	R 377,770	R 392,759
220	2980	315L	70	1320	R 350,873	R 368,822
250	2985	355M/L	90	1750	R 432,828	R 450,339
250	2980	315L	70	1350	R 372,666	R 389,432
280	2980	315L	70	1550	R 456,636	R 479,704
300	2985	355M/L	90	1850	R 501,437	R 526,509
315	2983	355M/L	90	1950	R 518,494	R 539,602
355	2988	355M/L	90	1950	R 588,922	R 612,896
400	2985	355A/B	90	2250	R 675,441	R 703,066
450	2985	355A/B	90	2400	R 727,771	R 757,240

Note: Prices Exclude VAT.



THREE PHASE CAST IRON MOTOR IE3 TOP PREMIUM EFFICIENCY W22

Class H Insulation

380V / 400V / 415V or 525V / 550V / 1000V

IP66

kW	Frame Size	r/min	Current			Torque			Allowed locked rotor time (s) Hot	Efficiency		Power Factor	
			400V In(A)	525V In(A)	Lock Rotor Current I/In	Full Load Torque Nm	Lock Rotor Torque Tl/Tn	Break-down Torque Tb/Tn		50%	75%	75%	100%
			0.18	63	2860	0.53	0.41	5.2		0.60	3	3.2	22
0.25	63	2805	0.67	0.51	5.5	0.85	3.2	3.2	17	63.0	68.0	0.68	0.77
0.37	71	2820	0.85	0.65	6	1.25	2.5	2.5	12	73.0	73.8	0.79	0.85
0.55	71	2770	1.19	0.91	5.9	1.90	3	3	18	75.0	76.0	0.81	0.86
0.75	80	2850	1.63	1.24	7.5	2.51	3.9	3.5	25	80.0	82.0	0.75	0.82
1.1	80	2830	2.33	1.78	7.4	3.71	3.6	3.6	23	81.0	83.5	0.76	0.82
1.5	90S	2875	5.37	2.35	7.6	4.98	3.3	3.3	15	83.0	85.0	0.76	0.83
2.2	90L	2865	4.43	3.38	7.5	7.33	3.1	3.4	12	85.5	86.0	0.77	0.83
3	100L	2910	5.77	4.40	8.5	9.85	3.4	3.4	15	85.5	87.3	0.81	0.86
4	112M	2900	7.59	5.78	7.7	13.2	2.9	3.5	22	88.0	88.4	0.80	0.86
5.5	132S	2940	10.6	8.08	7.9	17.9	2.4	3.5	12	86.9	88.7	0.78	0.84
7.5	132S	2935	14.1	10.7	8.5	24.4	3	3.6	10	88.5	89.8	0.80	0.85
9.2	132M	2935	16.6	12.6	8.5	29.9	2.8	3.1	16	90.4	91.1	0.84	0.88
11	160M	2950	20.0	15.2	8	35.6	2.8	3.4	12	90.3	91.4	0.82	0.87
15	160M	2945	27.7	21.1	8.3	48.6	2.8	3.5	8	90.9	91.8	0.79	0.85
18.5	160L	2945	33.9	25.8	8.6	60.0	3.1	3.7	6	91.5	92.3	0.80	0.85
22	180M	2950	39.7	30.2	8.3	71.2	2.7	3.6	6	92.3	93.0	0.80	0.86
30	200L	2965	54.5	41.5	7.7	96.6	3	3	16	92.2	93.2	0.80	0.85
37	200L	2960	67.8	51.7	7.7	119	3.1	3	13	92.6	93.4	0.79	0.84
45	225S/M	2960	77.5	59.0	7.7	145	2.4	3.1	13	94.2	94.5	0.86	0.89
55	250S/M	2965	96.7	73.7	8	177	2.8	3.3	19	93.5	94.0	0.84	0.87
75	250S/M	2965	128	97.5	8.5	242	3	3.2	11	94.0	94.6	0.87	0.89
90	280S/M	2975	153	117	7.6	289	2.1	3.1	27	94.3	95.2	0.87	0.89
110	280S/M	2975	187	142	7.5	353	2.1	3	20	95.0	95.5	0.87	0.89
132	315S/M	2980	224	171	7.6	423	2.1	3.1	34	94.5	95.4	0.86	0.89
160	315S/M	2980	271	206	7.4	513	2	2.9	28	95.1	95.8	0.86	0.89
185	315S/M	2980	313	238	7.6	593	2.3	3.1	22	95.4	95.8	0.86	0.89
200	315L	2975	334	254	7.6	642	2.3	2.9	23	95.7	96.2	0.88	0.90
220	355M/L	2985	363	277	7.3	704	1.9	2.6	35	95.0	95.6	0.89	0.91
220	315L	2980	368	280	8.5	705	2.7	3.3	23	95.9	96.0	0.88	0.90
250	355M/L	2985	413	315	7.7	800	2.4	2.7	30	95.0	95.6	0.89	0.91
250	315L	2980	413	315	7.8	801	2.7	2.9	21	96.3	96.0	0.90	0.91
280	315L	2980	463	353	7.5	897	2.5	2.7	22	95.4	95.8	0.89	0.91
300	355M/L	2985	496	378	8	960	2.3	2.9	22	95.4	95.8	0.89	0.91
**315	355M/L	2983	520	396	7.7	1008	2.6	2.7	23	95.5	96.0	0.90	0.91
**355	355M/L	2988	594	453	9.5	1135	2.6	3.2	14	95.3	95.6	0.88	0.90
**400	355A/B	2985	658	501	7.6	1280	2.4	2.8	31	95.8	96.2	0.89	0.91
**450	355A/B	2985	740	564	7.5	1440	2.5	2.7	31	95.8	96.2	0.90	0.91

(**) Fitted with air deflector on drive end shield
All values rated at 400V

THREE PHASE CAST IRON MOTOR IE3 TOP PREMIUM EFFICIENCY W22

Class H Insulation

IP66

380V / 400V / 415V or 525V / 550V / 1000V

4 Pole					Excl. VAT	
kW	r/min	Frame Size	Shaft (mm)	Weight (kg)	Foot Mounted	Flange Mounted
0.18	1370	63	11	14	R 2,602	R 3,297
0.25	1410	71	14	11.2	R 3,000	R 3,810
0.37	1385	71	14	11.4	R 3,089	R 3,900
0.55	1420	80	19	14.7	R 3,356	R 4,169
0.75	1430	80	19	15.9	R 3,844	R 4,805
1.1	1450	90S	24	21.1	R 4,242	R 5,151
1.5	1445	90L	24	24.6	R 5,330	R 6,215
2.2	1435	100L	28	32.5	R 6,228	R 7,461
3	1440	*L100L	28	38	R 7,194	R 8,524
4	1450	112M	28	45.7	R 8,256	R 9,479
5.5	1460	132S	38	66.3	R 10,041	R 11,481
7.5	1460	132M	38	75.1	R 12,295	R 14,187
9.2	1465	132M/L	38	85	R 16,952	R 19,825
11	1470	160M	42	125	R 19,359	R 21,916
15	1465	160L	42	147	R 25,116	R 28,188
18.5	1470	180M	48	171	R 30,838	R 34,610
22	1470	180L	48	193	R 37,257	R 41,498
30	1480	200L	55	245	R 44,569	R 49,933
37	1480	225S/M	60	389	R 61,699	R 68,072
45	1475	225S/M	60	417	R 71,139	R 79,257
55	1480	250S/M	70	507	R 91,568	R 97,756
75	1480	250S/M	70	530	R 109,382	R 118,975
90	1485	280S/M	80	788	R 125,954	R 135,327
110	1485	280S/M	80	800	R 151,062	R 163,832
132	1490	315S/M	85	1066	R 175,991	R 196,948
160	1490	315S/M	85	1171	R 195,750	R 213,231
185	1490	315S/M	90	1234	R 233,514	R 245,435
200	1485	315S/M	90	1332	R 242,569	R 254,274
220	1490	355M/L	100	1510	R 319,701	R 334,163
250	1490	355M/L	100	1550	R 362,679	R 398,463
260	1490	355M/L	100	1550	R 369,365	R 402,123
280	1490	355M/L	100	1600	R 400,074	R 420,041
300	1490	355M/L	100	1650	R 412,596	R 439,110
315	1491	355M/L	100	1750	R 436,215	R 458,196
330	1490	355M/L	100	1810	R 453,272	R 487,765
355	1490	355M/L	100	1878	R 487,038	R 506,744
400	1490	355A/B	100	2089	R 563,101	R 586,021
450	1490	355A/B	110	2400	R 636,132	R 661,791
500 (a)	1490	355A/B	125	2600	R 680,785	R 708,343

Motors from Frame Size 280S/M fitted with bearing shaft locking device for transport and should be removed only after installation.

(a) Temperature Rise 105K

Note: Prices Exclude VAT.



THREE PHASE CAST IRON MOTOR IE3 TOP PREMIUM EFFICIENCY W22

Class H Insulation

380V / 400V / 415V or 525V / 550V / 1000V

IP66

kW	Frame Size	r/min	Current			Torque			Allowed locked rotor time (s) Hot	Efficiency		Power Factor	
			400V In(A)	525V In(A)	Lock Rotor Current I _L /I _n	Full Load Torque Nm	Lock Rotor Torque T _L /T _n	Break-down Torque T _b /T _n		50%	75%	75%	100%
			0.18	63	1370	0.52	0.39	4.7		1.25	2.1	2.4	30
0.25	71	1410	0.68	0.52	4.8	1.69	2.4	2.4	30	69.0	72.0	0.62	0.72
0.37	71	1385	0.99	0.75	4.8	2.55	2.8	2.9	30	73.0	75.0	0.62	0.70
0.55	80	1420	1.23	0.94	6.6	3.70	2.8	3	20	77.0	79.0	0.74	0.80
0.75	80	1430	1.64	1.25	7	5.01	3.2	3.4	18	80.0	82.0	0.71	0.80
1.1	90S	1450	2.35	1.79	7.6	7.24	2.5	2.9	15	83.0	84.5	0.72	0.80
1.5	90L	1445	3.17	2.42	7.4	9.91	2.6	3.0	13	84.0	86.0	0.72	0.80
2.2	100L	1435	4.56	3.47	7.4	14.6	3.2	3.5	18	86.5	87.0	0.73	0.80
3	*L100L	1440	6.15	4.69	7.8	19.9	3.9	3.2	15	87.0	88.0	0.73	0.80
4	112M	1450	8.23	6.27	7	26.3	2.3	3.1	15	88.7	89.1	0.72	0.79
5.5	132S	1460	10.4	7.92	8.3	36.0	2.1	3.3	12	89.0	89.6	0.80	0.85
7.5	132M	1460	14.2	10.8	8.3	49.1	2.4	3.5	7	90.5	90.8	0.76	0.84
9.2	132M/L	1465	17.4	13.3	8.6	60.0	2.8	3.5	10	90.3	91.0	0.76	0.82
11	160M	1470	20.9	15.9	7.5	71.5	2.8	3.2	11	91.1	91.8	0.77	0.83
15	160L	1465	27.9	21.3	7.2	97.8	2.8	3.1	8	92.2	92.5	0.78	0.84
18.5	180M	1470	35.1	26.7	7.4	120	3	3.2	13	92.2	92.8	0.76	0.82
22	180L	1470	41.0	31.2	7.3	143	3.4	3.4	11	92.3	93.0	0.77	0.83
30	200L	1480	57.1	43.5	7.5	194	2.8	3.1	12	92.9	93.6	0.75	0.81
37	225S/M	1480	66.8	50.9	7.7	239	2.8	3.3	13	93.4	94.0	0.80	0.85
45	225S/M	1475	80.9	61.6	7.5	291	2.8	3.1	14	93.7	94.1	0.81	0.85
55	250S/M	1480	98.6	75.1	7.5	355	2.8	3	14	94.3	94.7	0.80	0.85
75	250S/M	1480	131	99.8	7.8	484	2.8	3.3	8	94.5	94.8	0.83	0.87
90	280S/M	1485	158	120	7	579	2.2	2.5	30	94.9	95.4	0.83	0.86
110	280S/M	1485	193	147	7.7	707	2.5	2.9	19	95.3	95.6	0.82	0.86
132	315S/M	1490	231	176	7.5	846	2.5	2.7	30	95.1	95.7	0.82	0.86
160	315S/M	1490	280	213	7.7	1026	2.6	2.7	28	95.2	95.9	0.82	0.86
185	315S/M	1490	327	249	7.8	1186	2.7	2.9	25	95.5	96.1	0.80	0.85
200	315S/M	1485	346	264	6.7	1286	2.4	2.4	21	95.8	96.0	0.85	0.87
220	355M/L	1490	388	296	7.4	1410	2.2	2.5	20	96.0	96.6	0.80	0.85
250	355M/L	1490	436	332	7.3	1602	2.3	2.5	26	95.9	96.6	0.82	0.86
260	355M/L	1490	454	346	7.3	1666	2.3	2.5	26	95.9	96.6	0.82	0.86
280	355M/L	1490	488	372	7.3	1795	2.4	2.6	20	95.9	96.0	0.83	0.86
300	355M/L	1490	530	404	7.6	1923	2.3	2.5	19	95.8	96.0	0.80	0.85
315	355M/L	1491	562	428	7.9	2018	2.9	2.8	17	96.1	96.3	0.80	0.84
330	355M/L	1490	583	444	7.1	2115	2.5	2.5	20	95.8	96.0	0.82	0.85
**355	355M/L	1490	618	471	7.2	2275	2.4	2.5	15	95.9	96.5	0.83	0.86
**400	355A/B	1490	714	544	7.6	2564	2.6	2.9	20	95.7	96.1	0.79	0.84
**450	355A/B	1490	804	613	7	2884	2.8	2.8	20	95.8	96.1	0.80	0.84
**500	355A/B	1490	882	672	8.3	3205	2.8	2.8	22	95.9	96.3	0.81	0.85

(*) Letter "L" means in accordance with IE 3 efficiency levels and increase in total length of motor.

(**) Fitted with air deflector on drive end shield

All values rated at 400V

THREE PHASE CAST IRON MOTOR IE3 TOP PREMIUM EFFICIENCY W22

Class H Insulation

IP66

380V / 400V / 415V or 525V / 550V / 1000V

6 Pole					Excl. VAT	
kW	r/min	Frame Size	Shaft (mm)	Weight (kg)	Foot Mounted	Flange Mounted
0.25	955	80	19	12	R 3,871	R 4,861
0.37	925	80	19	14.3	R 3,970	R 4,931
0.55	945	*L80	19	18.8	R 5,073	R 6,366
0.75	950	*L90S	24	24.2	R 5,442	R 6,559
1.1	945	*L90L	24	28.5	R 6,733	R 8,113
1.5	955	100L	28	33.5	R 7,339	R 8,899
2.2	960	112M	28	46	R 8,808	R 10,165
3	970	132S	38	61.5	R 10,960	R 12,784
4	965	132M	38	69.8	R 13,213	R 15,331
5.5	965	132M/L	38	78	R 15,299	R 17,907
7.5	975	160M	42	118	R 22,393	R 25,348
11	975	160L	42	143	R 33,495	R 37,771
15	975	180L	48	181	R 43,681	R 50,523
18.5	980	200L	55	222	R 49,173	R 55,618
22	980	200L	55	242	R 56,888	R 63,812
30	980	225S/M	60	404	R 80,830	R 90,947
37	985	250S/M	70	497	R 101,135	R 110,994
45	985	250S/M	70	490	R 123,389	R 135,797
55	990	280S/M	80	721	R 136,882	R 147,688
75	990	280S/M	80	725	R 162,483	R 175,768
90	990	315S/M	85	990	R 196,679	R 214,270
110	990	315S/M	85	1040	R 236,176	R 254,968
132	990	315S/M	85	1100	R 272,578	R 280,757
160	993	355M/L	100	1500	R 314,081	R 324,766
185	994	355M/L	100	1550	R 314,534	R 338,055
200	993	355M/L	100	1676	R 347,852	R 368,253
220	995	355M/L	100	1857	R 459,711	R 505,385
250	993	355M/L	100	1830	R 475,215	R 518,643
280	994	355M/L	100	1970	R 500,520	R 526,205
300	992	355M/L	100	2493	R 545,879	R 573,136
315	990	355M/L	100	2493	R 570,640	R 599,134
355	990	355A/B	100	2200	R 596,523	R 626,348
400(a)	990	355A/B	100	2346	R 623,581	R 654,758

Motors from Frame Size 280S/M fitted with bearing shaft locking device for transport and should be removed only after installation.

(a) Temperature Rise 105K

Note: Prices Exclude VAT.



THREE PHASE CAST IRON MOTOR IE3 TOP PREMIUM EFFICIENCY W22

Class H Insulation

IP66

380V / 400V / 415V or 525V / 550V / 1000V

kW	Frame	r/min	Current			Torque			Allowed locked rotor time (s) Hot	Efficiency		Power Factor	
			400V In(A)	525V In(A)	Lock Rotor Current I _L /I _n	Full Load Torque Nm	Lock Rotor Torque T _L /T _n	Break-down Torque T _b /T _n		50%	75%	75%	100%
0.25	80	955	0.74	0.56	4.3	2.50	1.7	2.4	25	63.6	68.5	0.60	0.71
0.37	80	925	0.97	0.74	4.5	3.82	1.9	2.1	25	66.0	69.5	0.65	0.75
0.55	*L80	945	1.49	1.14	5.1	5.56	2.9	3.1	20	70.5	75.2	0.58	0.69
0.75	*L90S	950	1.93	1.47	5.2	7.54	2.5	2.8	31	76.5	79.0	0.62	0.71
1.1	*L90L	945	2.69	2.05	5.5	11.1	2.5	2.8	20	79.3	81.4	0.64	0.73
1.5	100L	955	3.70	2.82	5.5	15.0	2.7	2.7	31	81.5	82.5	0.62	0.71
2.2	112M	960	5.22	3.98	6	21.9	2.5	2.6	26	83.0	84.5	0.64	0.72
3	132S	970	6.91	5.26	5.8	29.5	1.8	2.6	40	85.0	85.6	0.66	0.73
4	132M	965	9.11	6.94	6.1	39.6	1.9	2.7	20	86.0	86.8	0.66	0.73
5.5	132M/L	965	12.9	9.83	7	54.4	2.5	2.8	26	86.5	88.0	0.64	0.70
7.5	160M	975	14.8	11.3	6.3	73.5	2.2	2.7	16	88.5	89.3	0.76	0.82
11	160L	975	21.9	16.7	7.1	108	2.7	2.9	12	89.0	90.1	0.73	0.80
15	180L	975	28.2	21.5	7.7	147	2.6	3.2	8	91.5	91.5	0.79	0.84
18.5	200L	980	35.9	27.4	6.3	180	2.4	2.8	16	91.0	91.7	0.75	0.81
22	200L	980	42.4	32.3	6.4	214	2.4	2.8	15	91.4	92.0	0.76	0.81
30	225S/M	980	56.0	42.7	7.5	292	2.4	2.7	15	93.0	93.4	0.78	0.83
37	250S/M	985	67.2	51.2	7.2	359	2.4	2.7	20	93.3	93.5	0.81	0.85
45	250S/M	985	79.5	60.6	7.7	436	2.8	2.8	18	92.4	93.9	0.84	0.87
55	280S/M	990	103	78.5	6.8	531	2.3	2.8	24	94.0	94.2	0.77	0.82
75	280S/M	990	141	107	7.9	723	2.7	3.2	17	94.1	94.7	0.75	0.81
90	315S/M	990	165	126	6.4	868	2.2	2.5	35	95.1	95.5	0.78	0.83
110	315S/M	990	201	153	6.2	1061	2.1	2.4	31	95.4	95.6	0.80	0.83
132	315S/M	990	243	185	7.2	1273	2.6	2.7	25	95.4	95.8	0.77	0.82
160	355M/L	993	305	232	5.5	1539	1.8	2.1	33	94.9	95.6	0.74	0.79
185	355M/L	994	362	276	6.6	1777	2.1	2.4	34	94.9	95.6	0.72	0.77
200	355M/L	993	376	286	6.1	1923	2.1	2.3	39	95.5	96.0	0.76	0.80
220	355M/L	995	419	319	6.5	2112	2	2.2	36	95.5	96.1	0.74	0.79
250	355M/L	993	476	363	6.4	2404	2.2	2.3	38	95.7	95.9	0.75	0.79
280	355M/L	994	526	401	6.5	2690	2.3	2.5	38	95.1	95.1	0.75	0.80
300	355M/L	992	564	430	5.8	2888	1.9	2	25	95.8	96.0	0.74	0.80
**315	355M/L	990	593	452	6.1	3039	2.1	2.1	25	95.2	95.8	0.76	0.80
**355	355A/B	990	677	516	6.2	3424	2	2.3	29	95.3	95.7	0.74	0.79
**400	355A/B	990	762	581	6.1	3859	2	2.3	29	95.4	95.8	0.74	0.79

(*) Letter "L" means in accordance with IE 3 efficiency levels and increase in total length of motor.

(**) Fitted with air deflector on drive end shield

All values rated at 400V

THREE PHASE CAST IRON MOTOR IE3 TOP PREMIUM EFFICIENCY W22 Class H Insulation

IP66

380V / 400V / 415V or 525V / 550V / 1000V

8 Pole					Excl. VAT	
kW	r/min	Frame Size	Shaft (mm)	Weight (kg)	Foot Mounted	Flange Mounted
0.37	700	90S	24	19	R 5,182	R 6,662
0.55	690	90L	24	23	R 5,636	R 6,884
0.75	710	100L	28	30.5	R 8,333	R 10,160
1.1	710	100L	28	33	R 8,857	R 10,831
1.5	705	112M	28	43	R 11,566	R 13,421
2.2	710	132S	38	69	R 13,777	R 16,132
3	710	132M	38	75	R 16,479	R 19,447
4	730	160M	42	114	R 22,935	R 26,672
5.5	725	160M	42	123	R 27,410	R 30,839
7.5	731	160L	42	145	R 33,411	R 37,796
11	730	180L	48	185	R 46,889	R 53,887
15	730	200L	55	220	R 50,967	R 60,311
18.5	735	225S/M	60	377	R 69,722	R 79,742
22	735	225S/M	60	402	R 83,592	R 95,812
30	730	250S/M	70	490	R 108,148	R 121,407
37	730	250S/M	70	550	R 133,549	R 148,308
45	740	280S/M	80	720	R 144,892	R 161,463
55	740	280S/M	80	812	R 166,368	R 187,217
75	740	315S/M	85	1025	R 206,195	R 228,424
90	740	315S/M	85	1100	R 238,357	R 259,607
110	740	315S/M	85	1360	R 269,493	R 298,462
132	745	355M/L	100	1587	R 296,981	R 320,871
160	745	355M/L	100	1747	R 469,200	R 526,397
185	745	355M/L	100	1819	R 488,769	R 548,426
200	745	355M/L	100	1891	R 509,067	R 555,390
220	744	355M/L	100	2020	R 525,982	R 589,833
250	744	355A/B	100	2092	R 543,719	R 605,308
280	745	355A/B	100	2279	R 618,004	R 688,007

Motors from Frame Size 280S/M fitted with bearing shaft locking device for transport and should be removed only after installation.

Note: Prices Exclude VAT.



THREE PHASE CAST IRON MOTOR IE3 TOP PREMIUM EFFICIENCY W22

Class H Insulation

IP66

380V / 400V / 415V or 525V / 550V / 1000V

kW	Frame	r/min	Current			Torque			Allowed locked rotor time (s) Hot	Efficiency		Power Factor	
			400V In(A)	525V In(A)	Lock Rotor Current I _L /I _n	Full Load Torque Nm	Lock Rotor Torque T _L /T _n	Break-down Torque T _b /T _n		50%	75%	75%	100%
			0.37	90S	700	1.24	0.95	3.7		5.05	2	2.3	30
0.55	90L	690	1.62	1.23	3.8	7.61	1.9	2.2	29	65.0	70.0	0.57	0.67
0.75	100L	710	2.31	1.76	4.6	10.1	1.9	2.3	30	72.5	75.5	0.53	0.62
1.1	100L	710	3.30	2.51	4.6	14.8	1.9	2	30	73.0	76.0	0.53	0.62
1.5	112M	705	3.98	3.03	5	20.3	2.5	2.8	28	79.0	79.5	0.59	0.68
2.2	132S	710	5.37	4.09	6.2	29.6	2.3	2.5	27	81.5	82.0	0.65	0.72
3	132M	710	7.20	5.49	6.4	40.4	2.4	2.6	21	82.5	83.5	0.64	0.72
4	160M	730	9.87	7.52	5	52.3	2.1	2.3	34	85.0	86.0	0.61	0.68
5.5	160M	725	12.5	9.52	5	72.4	2.1	2.3	28	86.0	87.3	0.65	0.73
7.5	160L	731	18.0	13.7	5.5	98.0	2.2	2.5	22	86.5	88.0	0.59	0.68
11	180L	730	23.3	17.8	6.5	144	2.3	2.7	12	88.7	89.2	0.68	0.76
15	200L	730	32.6	24.8	4.8	196	1.9	2.1	34	89.0	89.6	0.68	0.74
18.5	225S/M	735	36.5	27.8	6.5	240	1.7	2.5	28	89.8	90.3	0.75	0.81
22	225S/M	735	44.3	33.8	7	286	2.1	2.7	20	90.3	90.8	0.73	0.79
30	250S/M	730	57.0	43.4	7.4	392	1.9	2.8	18	91.0	91.5	0.77	0.83
37	250S/M	730	73.5	56.0	8	484	2.3	3	12	91.5	92.0	0.72	0.79
45	280S/M	740	89.0	67.8	6	581	1.8	2.2	30	92.2	92.4	0.73	0.79
55	280S/M	740	111	84.6	5.8	710	2	2.1	26	92.2	92.7	0.71	0.77
75	315S/M	740	145	110	6	968	1.8	2.2	40	92.8	93.3	0.75	0.80
90	315S/M	740	173	132	6	1161	1.9	2.2	40	93.1	93.6	0.75	0.80
110	315S/M	740	214	163	6	1420	1.9	2.2	35	93.4	93.9	0.74	0.79
132	355M/L	745	256	195	6.5	1692	1.3	2.3	48	93.7	94.2	0.74	0.79
160	355M/L	745	305	232	6.4	2051	1.3	2.3	56	94.0	94.5	0.75	0.80
185	355M/L	745	361	275	6.9	2371	2	2.9	56	93.4	94.7	0.73	0.78
200	355M/L	745	381	290	6.2	2564	1.3	2.3	56	94.3	94.8	0.76	0.80
220	355M/L	744	428	326	7	2824	1.8	2.8	30	94.8	95.1	0.72	0.78
**250	355A/B	744	479	365	6.2	3209	1.6	2.5	47	94.8	95.3	0.73	0.79
**280	355A/B	745	551	420	7.8	3589	2.2	3.1	30	94.1	95.1	0.71	0.77

(**) Fitted with air deflector on drive end shield
All values rated at 400V

IS YOUR MOTOR VSD COMPATIBLE? ABSOLUTELY!



WISE® - WEG INSULATION SYSTEM EVOLUTION

The WEG, WISE® insulation system (WEG Insulation System Evolution) has resulted from using enhanced insulation materials during the production of the electric motor insulation.

Variable Speed Drive (VSD) compatible wire, insulation film, impregnation material and suitable cables are used during the insulation process.

During the enamelling process, the 99.9% pure copper wire is covered by layers of LackTherm varnishes, which have been especially developed by WEG for the insulation systems of electric motors. The LackTherm varnishes have excellent dielectric strength, flexibility, hardness, and chemical resistance with brilliant adhesion properties. During the impregnation process, the stator coils receive layers of high solid resins and water-based coatings which are environmentally friendly and free from harmful solvents as per (ISO 14000 Guidelines).

The use of motors with VSDs is permitted because the WISE® insulation system ensures that the motor windings are protected against voltage peaks and voltage variations that continuously occur during the operation with VSDs. The WISE® insulation system is capable of withstanding dV/dt and voltage impulse conditions described in the table below:

Motor rated voltage	Voltage Spikes at motor terminals (phase-phase)	dV/dt(*) at motor terminals (phase-phase)	Rise time*	Time between pulses
$V_n < 460 \text{ V}$	$\leq 1.600 \text{ V}$	$\leq 5.200 \text{ V}/\mu\text{s}$	$\geq 0,1 \mu\text{s}$	$\geq 6 \mu\text{s}$
$460 \text{ V} \leq V_n < 575 \text{ V}$	$\leq 2.000 \text{ V}$	$\leq 6.500 \text{ V}/\mu\text{s}$		
$575 \text{ V} \leq V_n \leq 690 \text{ V}$	$\leq 2.400 \text{ V}$	$\leq 7.800 \text{ V}/\mu\text{s}$		

(*) dV/dt and Rise time definition according to Nema Std. MG1 - Part 30.

With the introduction of the WISE® insulation system to all WEG motor lines, our customers have full assurance that all our WEG motors are VSD compatible. This is an important consideration to be made when selecting a motor to be controlled by a VSD.



THREE PHASE CAST IRON MOTOR

IE1 Standard Efficiency

W22



Minimum info required for orders and enquires.

W22 IE1

kW	
Speed	
Voltage	
Mounting	

5 Year Guarantee on W22 range

IP55

Class H Insulation

Δ 220-240V or Y 380-415V 50Hz (63 to 100 frame)

Δ 380-415V or Y 660-690V 50Hz (112 to 355 frame)

Δ 460V – 60Hz (112 to 355 frame)

or

Δ 525-550V - 50Hz (63 to 355 frame)

Suitable for VSD

Electrically Insulated non-drive end bearing via end shield (≥ 315 frame)

Thermistors 01/ phase (225 to 355 frame)

Please refer to the Optional Features and Parts section for information on Optional Features.

Efficiency values are given according to IEC 60034-2-1 they are calculated according to indirect method with stray load losses determined by measurement.

Paint finish RAL 5009

TEFC

All prices and values are subject to change without prior notice.

To obtain guaranteed values, please contact your nearest sales office.

Please check page 6 for the minimum requirements for accurate quotations and purchase orders.

THREE PHASE CAST IRON MOTOR IE1 STANDARD EFFICIENCY W22

Class H Insulation

380V / 400V / 415V or 525V / 550V

IP55

kW	r/min	2 Pole			Excl. VAT	
		Frame Size	Shaft (mm)	Weight (kg)	Foot Mounted	Flange Mounted
0.18	2790	63	11	4.7	R 2,264	R 2,868
0.25	2750	63	11	7.3	R 2,344	R 2,929
0.37	2835	71	14	9.1	R 2,839	R 3,545
0.55	2800	71	14	9.8	R 2,856	R 3,560
0.75	2825	80	19	12.3	R 3,698	R 4,633
1.1	2800	80	19	13.7	R 3,928	R 4,888
1.5	2860	90S	24	19.4	R 4,156	R 5,029
2.2 (a)	2860	90L	24	23.3	R 5,271	R 6,359
3	2900	100L	28	29.6	R 6,285	R 7,474
4	2900	112M	28	39.1	R 7,112	R 8,238
5.5	2920	132S	38	57.4	R 8,651	R 9,982
7.5	2920	132S	38	64.7	R 10,188	R 11,672
9.2	2925	132M	38	71.8	R 14,193	R 16,524
11	2930	160M	42	104	R 18,175	R 20,711
15	2930	160M	42	116	R 22,433	R 25,520
18.5	2940	160L	42	132	R 27,362	R 30,355
22	2950	180M	48	167	R 34,018	R 37,547
30	2955	200L	55	220	R 42,050	R 46,994
37	2955	200L	55	245	R 49,599	R 55,335
45	2960	225S/M	55	381	R 67,572	R 74,502
55	2960	250S/M	60	465	R 84,014	R 91,158
75	2965	250S/M	60	457	R 111,855	R 123,383
90	2975	280S/M	65	664	R 127,978	R 139,368
110	2975	280S/M	65	702	R 151,634	R 163,255
132	2980	315S/M	65	937	R 176,676	R 190,518
160	2980	315S/M	65	1022	R 201,888	R 220,488
185	2980	315S/M	70	993	R 240,018	R 250,012
200	2980	315S/M	70	1135	R 248,863	R 262,715
220	2985	355M/L	90	1496	R 328,888	R 341,475
220	2980	315L	70	1224	R 295,544	R 313,259
250	2986	355M/L	90	1592	R 377,343	R 391,600
250	2980	315L	70	1316	R 324,460	R 338,636
280 (a)	2980	315L	70	1443	R 397,073	R 417,132
300 (a)	2980	315L	70	1500	R 430,215	R 451,970
315	2985	355M/L	90	1770	R 451,159	R 469,218
355	2985	355M/L	90	1830	R 512,016	R 532,872

(a) Temperature Rise 105K

Note: Prices Exclude VAT.



THREE PHASE CAST IRON MOTOR IE1 STANDARD EFFICIENCY W22

Class H Insulation

IP55

380V / 400V / 415V or 525V / 550V

kW	Frame	r/min	Current			Torque			Allowed locked rotor time (s) Hot	Efficiency			Power Factor		
			400V In(A)	525V In(A)	Lock Rotor Current I/In	Full Load Torque Nm	Lock Rotor Torque Tl/Tn	Break-down Torque Tb/Tn		50%	75%	100%	50%	75%	100%
			0.18	63	2790	0.57	0.43	5.0		0.62	2.4	2.4	10	52.0	57.0
0.25	63	2750	0.75	0.57	4.3	0.87	2.3	2.3	25	52.0	57.0	60.0	0.50	0.68	0.80
0.37	71	2835	0.98	0.75	4.9	1.25	2.3	2.6	16	62.0	66.5	67.0	0.57	0.71	0.81
0.55	71	2800	1.38	1.05	5.0	1.88	2.3	2.5	7	64.0	70.0	70.0	0.56	0.71	0.82
0.75	80	2825	1.79	1.36	5.1	2.54	2.5	2.6	14	68.5	72.0	72.1	0.62	0.76	0.84
1.1	80	2800	2.47	1.88	6.3	3.75	2.6	2.6	7	74.0	76.5	76.5	0.64	0.77	0.84
1.5	90S	2860	3.32	2.53	6.3	5.01	2.7	2.6	7	77.5	78.0	78.5	0.63	0.76	0.83
2.2	90L	2860	4.58	3.49	6.8	7.35	2.6	2.9	7	81.0	81.5	81.5	0.63	0.77	0.85
3	100L	2900	6.07	4.62	6.9	9.9	2.3	3.0	9	81.5	82.0	82.0	0.69	0.81	0.87
4	112M	2900	7.81	5.95	6.8	13.2	2.4	3.0	9	82.0	84.0	85.0	0.71	0.82	0.87
5.5	132S	2920	10.6	8.08	6.5	18.0	2.1	3.0	11	85.0	86.0	86.0	0.71	0.81	0.87
7.5	132S	2920	14.4	11.0	6.9	24.5	2.3	2.6	11	85.5	86.5	86.5	0.72	0.82	0.87
9.2	132M	2925	17.6	13.4	7.5	30.0	2.7	3.1	7	87.0	87.5	87.5	0.70	0.81	0.86
11	160M	2930	20.9	15.9	6.8	35.9	2.0	2.7	11	87.8	88.6	88.4	0.70	0.81	0.86
15	160M	2930	28.1	21.4	7.2	48.9	2.6	3.1	9	89.5	89.8	89.5	0.71	0.81	0.86
18.5	160L	2940	34.4	26.2	7.8	60.1	2.6	3.1	7	90.3	90.7	90.3	0.70	0.80	0.86
22	180M	2950	39.7	30.2	7.3	71.2	2.2	3.1	7	90.7	91.0	90.8	0.76	0.84	0.88
30	200L	2955	54.3	41.4	6.9	97.0	2.5	2.7	18	91.6	92.0	91.6	0.76	0.84	0.87
37	200L	2955	66.7	50.8	6.7	120	2.6	2.6	16	92.0	92.5	92.0	0.76	0.84	0.87
45	225S/M	2960	80.8	61.6	6.9	145	2.5	2.8	10	91.8	92.6	92.4	0.76	0.84	0.87
55	250S/M	2960	96.1	73.2	6.7	177	2.2	2.7	12	92.2	93.0	92.8	0.79	0.86	0.89
75	250S/M	2965	130	99.0	7.8	242	2.6	3.0	9	93.0	93.5	93.3	0.78	0.86	0.89
90	280S/M	2975	156	119	7.0	289	2.0	2.8	20	93.0	93.8	93.7	0.80	0.87	0.89
110	280S/M	2975	190	145	7.0	353	2.0	2.8	20	93.5	94.2	94.0	0.79	0.86	0.89
132	315S/M	2980	227	173	6.7	423	1.8	2.6	24	93.5	94.3	94.3	0.79	0.86	0.89
160	315S/M	2980	272	207	7.6	513	2.0	2.8	21	94.0	94.5	94.5	0.80	0.87	0.90
185	315S/M	2980	321	245	7.7	593	2.0	2.8	14	94.4	94.6	94.6	0.77	0.84	0.88
200	315S/M	2980	339	258	7.7	641	2.1	2.8	17	94.4	94.7	94.6	0.80	0.87	0.90
220	355M/L	2985	373	284	7.7	704	1.8	2.8	20	94.5	94.8	94.7	0.83	0.88	0.90
220	315L	2980	373	284	8.0	705	2.3	2.8	14	94.5	94.8	94.7	0.82	0.88	0.90
250	355M/L	2986	423	322	8.3	800	2.7	2.8	20	94.5	94.8	94.7	0.86	0.88	0.90
250	315L	2980	419	319	7.9	801	2.4	2.8	14	94.5	94.8	94.7	0.83	0.88	0.91
280	315L	2980	474	361	8.5	897	2.8	2.8	14	94.5	94.9	94.8	0.84	0.88	0.90
300	315L	2980	506	386	7.5	961	2.5	2.5	12	94.8	95.0	95.0	0.84	0.88	0.90
**315	355M/L	2985	527	402	7.8	1,008	2.1	2.6	22	94.6	94.9	94.8	0.87	0.90	0.91
**355	355M/L	2985	594	453	9.3	1,136	2.5	3.1	14	94.6	95.0	94.8	0.86	0.90	0.91

(**) Fitted with air deflector on drive end shield
All values rated at 400V

THREE PHASE CAST IRON MOTOR IE1 STANDARD EFFICIENCY W22

Class H Insulation

IP55

380V / 400V / 415V or 525V / 550V

4 Pole					Excl. VAT	
kW	r/min	Frame Size	Shaft (mm)	Weight (kg)	Foot Mounted	Flange Mounted
0.18	1390	63	11	7.6	R 2,264	R 2,868
0.25	1390	71	14	9.2	R 2,609	R 3,313
0.37	1370	71	14	10	R 2,688	R 3,391
0.55	1440	80	19	13.2	R 2,918	R 3,621
0.75	1435	80	19	14.9	R 3,343	R 4,176
1.1	1450	90S	24	19.2	R 3,689	R 4,480
1.5	1445	90L	24	23.3	R 4,633	R 5,403
2.2	1430	100L	28	30.6	R 5,414	R 6,488
3	1420	100L	28	31	R 6,257	R 7,413
4	1440	112M	28	43	R 7,112	R 8,238
5.5	1470	132S	38	60.4	R 8,651	R 9,982
7.5	1460	132M	38	73.4	R 10,598	R 12,336
9.2	1455	132M	38	70	R 14,742	R 17,237
11	1460	160M	42	109	R 16,820	R 19,054
15	1470	160L	42	136	R 21,837	R 24,505
18.5	1470	180M	48	159	R 26,809	R 30,092
22	1465	180L	48	172	R 32,390	R 36,079
30	1470	200L	55	231	R 38,748	R 43,415
37	1478	225S/M	60	355	R 53,400	R 59,180
45	1475	225S/M	60	389	R 61,852	R 68,905
55	1475	250S/M	70	457	R 79,613	R 84,989
75	1479	250S/M	70	496	R 95,103	R 103,439
90	1485	280S/M	80	702	R 109,507	R 117,659
110	1485	280S/M	80	735	R 131,335	R 142,442
132	1490	315S/M	85	953	R 153,011	R 171,234
160	1490	315S/M	85	1012	R 170,192	R 185,390
185	1490	315S/M	90	1071	R 201,751	R 213,388
200	1490	315S/M	90	1216	R 210,893	R 221,073
220	1490	355M/L	100	1414	R 275,411	R 290,530
220	1490	315L	90	1330	R 275,411	R 290,530
250	1490	355M/L	100	1470	R 315,324	R 346,430
250	1490	315L	90	1399	R 315,324	R 346,430
260	1490	355M/L	100	1571	R 321,196	R 349,672
280	1490	355M/L	100	1510	R 347,834	R 365,199
280	1490	315L	90	1496	R 347,834	R 365,199
300	1490	355M/L	100	1560	R 358,723	R 381,771
300	1490	315L	90	1540	R 358,723	R 381,771
315	1490	355M/L	100	1670	R 379,258	R 398,369
315	1490	315L	90	1540	R 379,258	R 398,369
330	1490	355M/L	100	1769	R 394,087	R 424,076
355	1490	355M/L	100	1888	R 409,039	R 436,799
370	1490	355M/L	100	1971	R 441,691	R 468,771
400	1490	355M/L	100	1971	R 473,959	R 505,138

Motors from Frame Size 280S/M fitted with bearing shaft locking device for installation and should be removed only after installation.

Note: Prices Exclude VAT.



THREE PHASE CAST IRON MOTOR IE1 STANDARD EFFICIENCY W22

Class H Insulation

380V / 400V / 415V or 525V / 550V

IP55

kW	Frame	r/min	Current			Torque			Allowed locked rotor time (s) Hot	Efficiency			Power Factor		
			400V In(A)	525V In(A)	Lock Rotor Current I/In	Full Load Torque Nm	Lock Rotor Torque Tl/Tn	Break-down Torque Tb/Tn		50%	75%	100%	50%	75%	100%
			0.18	63	1390	0.62	0.469	3.8		1.24	1.9	1.9	16	51.0	55.0
0.25	71	1390	0.80	0.613	3.7	1.72	1.8	1.9	28	60.0	61.0	61.5	0.50	0.62	0.73
0.37	71	1370	1.11	0.846	3.6	2.58	2.0	2.2	28	58.0	62.0	66.0	0.50	0.64	0.73
0.55	80	1440	1.43	1.09	5.3	3.65	2.0	2.8	8	65.0	70.0	71.0	0.54	0.68	0.78
0.75	80	1435	1.90	1.45	5.1	4.99	2.1	2.3	7	67.0	72.0	72.3	0.58	0.70	0.79
1.1	90S	1450	2.56	1.95	5.8	7.24	1.8	2.4	7	72.5	75.5	75.5	0.60	0.74	0.82
1.5	90L	1445	3.41	2.6	5.8	9.9	1.9	2.2	8	74.5	77.5	77.5	0.58	0.73	0.82
2.2	100L	1430	4.84	3.69	5.6	14.7	2.4	2.6	9	79.0	80.0	80.0	0.60	0.74	0.82
3	100L	1420	6.56	5	6.5	20.2	2.8	2.8	8	79.0	81.5	81.5	0.57	0.72	0.81
4	112M	1440	8.64	6.58	6.2	26.5	2.1	2.5	9	82.5	83.5	83.5	0.61	0.73	0.80
5.5	132S	1470	11.1	8.46	7.2	35.7	2.0	2.8	7	84.0	85.5	85.5	0.63	0.77	0.84
7.5	132M	1460	15.2	11.6	6.4	49.1	2.0	2.5	8	85.5	87.0	87.0	0.63	0.75	0.82
9.2	132M	1455	17.8	13.6	7.5	60.4	2.2	2.8	6	86.5	87.7	87.7	0.64	0.78	0.85
11	160M	1460	22.0	16.8	6.0	72.0	2.1	2.5	9	87.0	88.0	88.0	0.64	0.76	0.82
15	160L	1470	29.2	22.2	7.1	97.4	2.6	3.1	8	89.0	89.7	89.3	0.66	0.76	0.83
18.5	180M	1470	36.1	27.5	7.5	120	2.7	3.1	12	88.0	89.5	90.2	0.65	0.75	0.82
22	180L	1465	41.7	31.8	6.6	143	2.4	2.9	10	90.0	90.8	90.7	0.66	0.77	0.84
30	200L	1470	56.3	42.9	6.6	195	2.3	2.6	13	91.3	91.7	91.5	0.68	0.78	0.84
37	225S/M	1478	68.1	51.9	7.0	239	2.3	2.7	10	92.0	92.4	92.2	0.71	0.81	0.85
45	225S/M	1475	81.6	62.2	7.5	291	2.5	2.7	10	92.2	92.4	92.6	0.72	0.82	0.86
55	250S/M	1475	100	76.2	6.7	356	2.4	2.6	12	92.9	93.2	93.1	0.73	0.82	0.85
75	250S/M	1479	135	103	7.6	484	2.4	3.0	8	93.1	93.4	93.5	0.73	0.82	0.86
90	280S/M	1485	163	124	6.8	579	2.1	2.5	20	93.2	93.8	93.8	0.75	0.83	0.85
110	280S/M	1485	201	153	6.8	707	2.1	2.6	16	93.5	94.2	94.1	0.73	0.82	0.84
132	315S/M	1490	235	179	6.9	846	2.3	2.4	22	93.9	94.5	94.3	0.74	0.83	0.86
160	315S/M	1490	284	216	7.3	1026	2.4	2.5	18	94.1	94.6	94.5	0.73	0.82	0.86
185	315S/M	1490	328	250	6.9	1186	2.4	2.3	17	94.3	94.7	94.6	0.74	0.82	0.86
200	315S/M	1490	350	267	6.9	1282	2.3	2.4	16	94.4	94.8	94.7	0.76	0.84	0.87
220	355M/L	1490	394	300	6.4	1410	2.0	2.2	18	94.6	94.9	94.8	0.73	0.81	0.85
220	315L	1490	389	296	7.7	1410	2.6	2.4	14	94.5	94.9	94.8	0.74	0.83	0.86
250	355M/L	1490	447	341	6.5	1602	2.1	2.4	18	94.6	94.9	94.9	0.73	0.82	0.85
250	315L	1490	443	338	7.8	1602	2.7	2.5	12	94.6	94.9	94.8	0.75	0.83	0.86
260	355M/L	1490	465	354	6.4	1666	2.4	2.4	14	94.6	95.0	94.9	0.73	0.82	0.85
280	355M/L	1490	501	382	6.6	1795	2.1	2.4	14	94.6	95.0	94.9	0.74	0.82	0.85
280	315L	1490	495	377	7.9	1795	2.7	2.5	12	94.6	95.0	94.9	0.74	0.82	0.86
300	355M/L	1490	537	409	7.2	1923	2.2	2.4	18	94.6	95.0	94.9	0.74	0.82	0.85
300	315L	1490	537	409	7.6	1923	2.5	2.5	11	94.0	94.9	94.9	0.72	0.80	0.85
315	355M/L	1490	557	424	7.2	2019	2.4	2.4	14	94.6	95.0	94.9	0.74	0.82	0.86
315	315L	1490	570	434	7.9	2019	3.0	3.2	11	94.6	95.0	95.0	0.68	0.79	0.84
330	355M/L	1490	584	445	6.8	2115	2.2	2.4	17	94.6	95.0	94.9	0.75	0.83	0.86
**355	355M/L	1490	628	478	6.9	2275	2.4	2.3	15	94.6	95.0	94.9	0.75	0.83	0.86
**370	355M/L	1490	654	498	7.3	2371	2.6	2.4	11	94.9	95.1	94.9	0.75	0.83	0.86
**400	355M/L	1490	707	539	7.3	2564	2.6	2.4	11	94.7	95.1	94.9	0.74	0.82	0.86

(**) Fitted with air deflector on drive end shield. All values rated at 400V

THREE PHASE CAST IRON MOTOR IE1 STANDARD EFFICIENCY W22

Class H Insulation

380V / 400V / 415V or 525V / 550V

IP55

6 Pole					Excl. VAT	
kW	r/min	Frame Size	Shaft (mm)	Weight (kg)	Foot Mounted	Flange Mounted
0.25	950	80	19	8.5	R 3,366	R 4,227
0.37	905	80	19	13.5	R 3,451	R 4,285
0.55	930	80	19	15.4	R 4,409	R 5,535
0.75	945	90S	24	18	R 4,733	R 5,703
1.1	940	90L	24	24.6	R 5,854	R 7,053
1.5	945	100L	28	27.6	R 6,378	R 7,736
2.2	950	112M	28	37.5	R 7,657	R 8,840
3	955	132S	38	55.8	R 9,531	R 11,115
4	960	132M	38	65.4	R 11,486	R 13,332
5.5	960	132M	38	77.1	R 13,300	R 15,570
7.5	965	160M	42	104	R 19,471	R 22,038
11	965	160L	42	126	R 29,123	R 32,837
15	970	180L	48	166	R 37,980	R 43,926
18.5	975	200L	55	190	R 42,752	R 48,353
22	975	200L	55	227	R 49,461	R 55,478
30	985	225S/M	60	383	R 70,279	R 79,071
37	985	250S/M	70	461	R 87,928	R 96,501
45	981	250S/M	70	466	R 107,275	R 118,068
55	985	280S/M	80	607	R 119,009	R 128,403
75	985	280S/M	80	682	R 141,267	R 152,816
90	990	315S/M	85	883	R 170,996	R 186,293
110	990	315S/M	85	941	R 205,337	R 221,679
132	990	315S/M	85	1103	R 236,988	R 244,097
160	992	355M/L	100	1416	R 273,071	R 282,359
160	990	315L	90	1203	R 273,071	R 282,359
185	990	355M/L	100	1530	R 273,567	R 293,912
185	990	315L	90	1346	R 273,567	R 293,912
200	990	355M/L	100	1600	R 301,598	R 320,167
200	990	315L	90	1488	R 301,598	R 320,167
220	990	355M/L	100	1678	R 399,684	R 439,393
220	990	315L	90	1563	R 399,684	R 439,393
250	990	355M/L	100	1752	R 413,166	R 450,922
250 (a)	990	315L	90	1399	R 413,166	R 450,922
280	990	355M/L	100	1839	R 435,166	R 457,496
300	990	355M/L	100	1900	R 474,602	R 498,301
315	995	355M/L	100	1979	R 496,209	R 520,985

Motors from Frame Size 280S/M fitted with bearing shaft locking device for transport and should be removed only after installation.

(a) Temperature Rise 105K

Note: Prices Exclude VAT.



THREE PHASE CAST IRON MOTOR IE1 STANDARD EFFICIENCY W22

Class H Insulation

380V / 400V / 415V or 525V / 550V

IP55

kW	Frame	r/min	Current			Torque			Allowed locked rotor time (s) Hot	Efficiency			Power Factor		
			400V In(A)	525V In(A)	Lock Rotor Current I _L /I _n	Full Load Torque Nm	Lock Rotor Torque T _L /T _n	Break-down Torque T _b /T _n		50%	75%	100%	50%	75%	100%
			0.25	80	950	0.97	0.74	4.1		2.51	2.1	2.7	26	51.0	58.0
0.37	80	905	1.13	0.86	3.6	3.90	1.7	1.7	16	55.0	60.0	63.0	0.50	0.64	0.75
0.55	80	930	1.62	1.23	4.5	5.65	2.3	2.3	10	60.0	65.0	67.0	0.50	0.63	0.73
0.75	90S	945	2.06	1.57	5.0	7.58	2.0	2.1	17	68.0	70.0	70.0	0.51	0.65	0.75
1.1	90L	940	3.02	2.30	5.0	11.2	2.7	2.6	9	70.0	72.0	73.0	0.47	0.60	0.72
1.5	100L	945	3.90	2.97	4.4	15.2	1.9	2.2	14	76.0	77.0	76.0	0.52	0.66	0.73
2.2	112M	950	5.50	4.19	5.1	22.1	2.3	2.5	10	78.0	78.5	78.0	0.53	0.66	0.74
3	132S	955	6.94	5.29	5.3	30.0	2.0	2.2	20	81.0	82.0	81.0	0.58	0.70	0.77
4	132M	960	9.46	7.21	5.8	39.8	2.1	2.2	19	81.0	82.5	82.5	0.54	0.66	0.74
5.5	132M	960	13.0	9.90	6.2	54.7	2.3	2.9	19	82.5	84.5	84.5	0.51	0.64	0.72
7.5	160M	965	15.3	11.7	5.4	74.2	1.9	2.3	12	85.3	85.5	85.3	0.64	0.76	0.83
11	160L	965	21.9	16.7	5.8	109	2.1	2.4	11	87.0	87.5	87.2	0.65	0.77	0.83
15	180L	970	28.2	21.5	6.8	148	2.3	2.7	6	88.0	88.5	88.2	0.72	0.82	0.87
18.5	200L	975	36.6	27.9	5.7	181	2.1	2.4	12	88.3	89.3	88.9	0.64	0.76	0.82
22	200L	975	42.7	32.5	6.0	215	2.2	2.4	13	89.5	90.0	89.7	0.67	0.77	0.83
30	225S/M	985	55.2	42.1	7.2	291	2.6	2.7	12	91.0	91.5	91.2	0.73	0.82	0.86
37	250S/M	985	67.7	51.6	6.7	359	2.1	2.4	14	91.7	91.9	91.7	0.74	0.83	0.86
45	250S/M	981	81.9	62.4	6.5	438	2.1	2.3	15	92.2	92.4	92.2	0.75	0.83	0.86
55	280S/M	985	106	80.8	6.0	533	2.2	2.5	20	92.7	92.7	92.6	0.64	0.75	0.81
75	280S/M	985	140	107	6.5	727	2.0	2.5	14	93.0	93.1	93.0	0.68	0.79	0.83
90	315S/M	990	168	128	6.2	868	2.0	2.2	18	93.4	93.6	93.4	0.70	0.80	0.83
110	315S/M	990	204	155	6.2	1,061	2.0	2.2	20	93.7	94.0	93.8	0.70	0.80	0.83
132	315S/M	990	238	181	6.2	1,273	2.1	2.2	18	94.0	94.2	94.1	0.73	0.82	0.85
160	355M/L	992	309	235	5.6	1,540	1.8	2.0	32	94.0	94.5	94.5	0.64	0.74	0.79
160	315L	990	295	225	6.5	1,543	2.2	2.3	14	94.1	94.4	94.4	0.69	0.79	0.83
185	355M/L	990	357	272	6.0	1,785	2.0	2.2	30	94.3	94.6	94.6	0.63	0.74	0.79
185	315L	990	340	259	7.1	1,785	2.3	2.4	12	94.2	94.5	94.6	0.70	0.79	0.83
200	355M/L	990	381	290	6.0	1,929	2.0	2.1	32	94.4	94.7	94.7	0.64	0.75	0.80
200	315L	990	368	280	7.3	1,929	2.4	2.5	12	94.3	94.6	94.6	0.70	0.80	0.83
220	355M/L	990	419	319	6.4	2,122	2.1	2.2	30	94.4	94.8	94.7	0.64	0.74	0.80
220	315L	990	404	308	6.8	2,122	2.3	2.3	15	94.4	94.7	94.7	0.70	0.80	0.83
250	355M/L	990	476	363	6.0	2,412	2.1	2.1	32	94.4	94.7	94.7	0.65	0.75	0.80
250	315L	990	469	357	7.0	2,412	2.5	2.5	11	94.8	94.8	94.9	0.65	0.77	0.81
280	355M/L	990	533	406	6.2	2,701	2.1	2.1	28	94.5	94.8	94.8	0.64	0.75	0.80
300	355M/L	990	579	441	6.2	2,894	2.2	2.2	30	94.4	94.7	94.6	0.63	0.74	0.79
**315	355M/L	995	592	451	6.2	3,023	2.2	2.2	28	94.5	94.8	94.8	0.66	0.76	0.81

(**) Fitted with air deflector on drive end shield
All values rated at 400V

THREE PHASE CAST IRON MOTOR IE1 STANDARD EFFICIENCY W22

Class H Insulation

IP55

380V / 400V / 415V or 525V / 550V

8 Pole					Excl. VAT	
kW	r/min	Frame Size	Shaft (mm)	Weight (kg)	Foot Mounted	Flange Mounted
0.37	685	90S	24	17.7	R 4,505	R 5,680
0.55	675	90L	24	23.1	R 4,900	R 5,869
0.75	705	100L	28	25.3	R 7,245	R 8,660
1.1	700	100L	28	29.7	R 7,701	R 9,236
1.5	700	112M	28	37.7	R 10,056	R 11,440
2.2	710	132S	38	55.3	R 11,975	R 13,753
3	710	132M	38	65	R 14,322	R 16,575
4	720	160M	42	101	R 19,940	R 22,736
5.5	720	160M	42	110	R 23,831	R 26,540
7.5	720	160L	42	125	R 29,050	R 32,216
11	730	180L	48	175	R 40,766	R 45,932
15	725	200L	55	205	R 44,316	R 51,409
18.5	735	225S/M	60	339	R 60,616	R 67,971
22	730	225S/M	60	358	R 72,678	R 81,669
30	735	250S/M	70	433	R 94,028	R 103,485
37	730	250S/M	70	475	R 116,112	R 126,414
45	740	280S/M	80	617	R 125,969	R 137,627
55	740	280S/M	80	826	R 144,644	R 159,579
75	740	315S/M	85	998	R 179,273	R 194,705
90	740	315S/M	85	982	R 207,233	R 221,283
110	740	315S/M	85	1180	R 234,303	R 254,398
132	745	355M/L	100	1448	R 257,191	R 273,506
132	740	315L	90	1290	R 257,191	R 273,506
160	745	355M/L	100	1448	R 407,934	R 448,693
160	740	315L	90	1350	R 407,934	R 448,693
185	743	355M/L	100	1653	R 424,950	R 467,468
185 (a)	740	315L	90	1520	R 424,950	R 467,468
200	745	355M/L	100	1725	R 442,597	R 473,403
220	745	355M/L	100	1839	R 457,301	R 502,764

Motors from Frame Size 280S/M fitted with bearing shaft locking device for transport and should be removed only after installation.

(a) Temperature Rise 105K

Note: Prices Exclude VAT.



THREE PHASE CAST IRON MOTOR IE1 STANDARD EFFICIENCY W22

Class H Insulation

380V / 400V / 415V or 525V / 550V

IP55

kW	Frame	r/min	Current			Torque			Allowed locked rotor time (s) Hot	Efficiency			Power Factor		
			400V In(A)	525V In(A)	Lock Rotor Current I _L /I _n	Full Load Torque Nm	Lock Rotor Torque T _L /T _n	Break-down Torque T _b /T _n		50%	75%	100%	50%	75%	100%
			0.37	90S	685	1.50	1.14	3.0		5.16	1.9	1.8	32	50.6	55.0
0.55	90L	675	2.00	1.52	3.3	7.78	1.9	2.0	25	58.0	60.0	60.0	0.43	0.56	0.66
0.75	100L	705	2.71	2.06	3.5	10.16	1.8	2.4	33	63.5	64.0	64.5	0.42	0.53	0.62
1.1	100L	700	3.44	2.62	4.0	15.01	1.7	2.3	27	65.0	65.5	70.0	0.45	0.57	0.66
1.5	112M	700	4.21	3.21	4.2	20.46	2.2	2.2	26	73.7	75.4	73.5	0.48	0.61	0.70
2.2	132S	710	5.35	4.08	6.1	29.59	2.5	2.8	22	75.8	78.0	77.1	0.55	0.68	0.77
3	132M	710	7.41	5.65	6.5	40.35	2.4	2.9	18	78.5	80.1	79.0	0.55	0.67	0.74
4	160M	720	9.84	7.50	4.7	53.06	2.0	2.1	17	79.5	82.0	81.5	0.52	0.65	0.72
5.5	160M	720	13.1	9.98	4.7	72.95	2.0	2.1	16	82.0	83.2	83.0	0.52	0.65	0.73
7.5	160L	720	17.4	13.3	4.9	99.48	2.2	2.2	16	84.0	85.5	85.0	0.52	0.65	0.73
11	180L	730	23.4	17.8	7.2	143.90	2.5	2.9	10	85.0	85.8	86.0	0.63	0.73	0.79
15	200L	725	32.6	24.8	4.6	197.59	1.9	2.0	22	86.5	87.0	87.5	0.58	0.70	0.76
18.5	225S/M	735	36.8	28.0	6.4	240.37	1.8	2.4	18	87.4	87.9	88.4	0.66	0.77	0.82
22	225S/M	730	44.6	34.0	6.4	287.81	1.8	2.4	16	87.9	88.4	88.9	0.66	0.76	0.80
30	250S/M	735	58.2	44.3	6.9	389.80	1.9	2.4	13	88.7	89.2	89.7	0.67	0.78	0.83
37	250S/M	730	71.4	54.4	6.9	484.04	1.9	2.7	12	89.1	89.6	90.1	0.67	0.78	0.83
45	280S/M	740	90.8	69.2	5.4	580.74	1.7	2.0	21	89.5	90.0	90.5	0.64	0.75	0.79
55	280S/M	740	111	84.6	5.4	709.80	1.7	2.0	20	89.8	90.3	90.8	0.64	0.75	0.79
75	315S/M	740	149	114	5.3	967.91	1.6	2.0	30	90.0	90.5	91.0	0.66	0.76	0.80
90	315S/M	740	177	135	5.8	1,161.49	1.8	2.1	26	90.7	91.2	91.7	0.66	0.76	0.80
110	315S/M	740	215	164	5.8	1,419.59	1.8	2.1	24	91.1	91.6	92.1	0.64	0.75	0.80
132	355M/L	745	261	199	6.0	1,692.08	1.2	2.1	48	91.4	91.9	92.4	0.62	0.74	0.79
132	315L	740	255	199	6.2	1,703.51	2.0	2.2	23	94.0	94.5	94.6	0.63	0.74	0.79
160	355M/L	745	261	240	6.0	2,051.01	1.2	2.1	48	91.4	91.9	92.4	0.62	0.74	0.79
160	315L	740	316	241	6.4	2,064.86	2.2	2.2	20	91.6	92.3	92.6	0.63	0.74	0.79
185	355M/L	743	362	276	6.5	2,377.86	1.6	2.1	46	91.9	92.3	92.3	0.64	0.75	0.80
185	315L	740	368	280	7.0	2,387.50	2.4	2.4	12	92.0	92.5	93.0	0.62	0.72	0.78
200	355M/L	745	392	299	6.2	2,563.76	1.5	2.2	44	92.3	92.8	93.3	0.63	0.74	0.79
220	355M/L	745	425	324	6.3	2,820.13	1.4	2.1	42	92.3	92.8	93.3	0.64	0.75	0.80

(**) Fitted with air deflector on drive end shield
All values rated at 400V

THREE PHASE ALUMINIUM MOTOR

IE1 Standard Efficiency

W11



Minimum info required for orders
and enquires.

WEG Aluminium

kW	
Speed	
Voltage	
Mounting	

2 Year Guarantee on W11 Range

IP55

Class F Insulation

Δ 220-240V or Y 380-415V 50Hz (63 to 100 frame)

Δ 380-415V or Y 660-690V 50Hz (112 to 160 frame)

Δ 460V – 60Hz (112 to 160 frame)

or

Δ 525-550V - 50Hz (63 to 160 frame)

Suitable for VSD

Paint finish RAL 5009

TEFC

All prices and values are subject to change without prior notice.

To obtain guaranteed values, please contact your nearest sales office.

Please check page 6 for the minimum requirements for accurate quotations and purchase orders.



ALUMINIUM THREE PHASE MOTOR IE1 STANDARD EFFICIENCY W11

Class F Insulation

IP55

380V / 400V / 415V or 525V / 550V

2 Pole				Mounting	
kW	r/min	Frame	Shaft	Foot	Flange
		Size	Dia.(mm)	Excl. VAT	Excl. VAT
0.18	2730	63	11	R 1,364	R 1,432
0.25	2720	63	11	R 1,415	R 1,486
0.37	2730	71	14	R 1,549	R 1,626
0.55	2710	71	14	R 1,592	R 1,672
0.75	2770	80	19	R 1,943	R 2,041
1.1	2770	80	19	R 2,151	R 2,258
1.5	2840	90S	24	R 2,632	R 2,764
2.2	2810	90L	24	R 2,772	R 2,910
3	2870	100L	28	R 3,665	R 3,848
4	2875	112M	28	R 5,351	R 5,618
5.5	2910	132S	38	R 6,486	R 6,810
7.5	2900	132M	38	R 7,458	R 7,831

4 Pole				Mounting	
kW	r/min	Frame	Shaft	Foot	Flange
		Size	Dia.(mm)	Excl. VAT	Excl. VAT
0.18	1360	63	11	R 1,364	R 1,432
0.25	1310	71	14	R 1,437	R 1,508
0.37	1320	71	14	R 1,657	R 1,740
0.55	1410	80	19	R 1,951	R 2,049
0.75	1395	80	19	R 2,026	R 2,128
1.1	1420	90S	24	R 2,357	R 2,474
1.5	1410	90L	24	R 2,632	R 2,764
2.2	1410	100L	28	R 3,525	R 3,701
3	1400	100L	28	R 4,036	R 4,238
4	1440	112M	28	R 4,956	R 5,204
5.5	1450	132S	38	R 6,641	R 6,973
7.5	1455	132M	38	R 7,887	R 8,282

6 Pole				Mounting	
kW	r/min	Frame	Shaft	Foot	Flange
		Size	Dia.(mm)	Excl. VAT	Excl. VAT
0.37	905	80	19	R 2,058	R 2,161
0.55	930	80	19	R 2,187	R 2,296
0.75	910	90S	24	R 2,386	R 2,505
1.1	925	90L	24	R 3,085	R 3,239
1.5	910	100L	28	R 3,424	R 3,595
2.2	920	112M	28	R 4,734	R 4,971
3	960	132S	38	R 6,421	R 6,742
4	960	132M	38	R 6,988	R 7,337
5.5	960	132M	38	R 9,817	R 10,307

Note: Prices Exclude VAT.

SINGLE PHASE ALUMINIUM MOTOR

IE1 Standard Efficiency

W21



Minimum info required for orders and enquires.

WEG Single Phase Aluminium Motor

kW	
Speed	
Voltage	
Mounting	

IP55

Class F Insulation

Single-Phase 220V or 440V 50 Hz
High Torque Motor (capacitor start and run)

Paint finish RAL 5009

TEFC

2 Year Guarantee on W11 Range

W21 IE1 STANDARD EFFICIENCY ALUMINIUM SINGLE PHASE MOTOR

Class F Insulation

220V High Torque

IP55

2 Pole				Mounting	
kW	r/min	Frame Size	Shaft Dia.(mm)	Foot Excl. VAT	Flange Excl. VAT
0.37	2910	71	14	R4,114	R4,409
0.55	2880	71	14	R4,249	R4,557
0.75	2900	80	19	R4,398	R4,698
1.1	2850	80	19	R5,047	R5,396
1.5	2900	90S	24	R5,837	R6,244
2.2	2890	90L	24	R8,061	R8,620
3	2910	100L	28	R8,933	R9,558
3.7	2900	112M	28	R10,372	R11,098
5.5	2910	132M	38	R13,884	R14,856
7.5	2930	132M	38	R15,749	R16,851

4 Pole				Mounting	
kW	r/min	Frame Size	Shaft Dia.(mm)	Foot Excl. VAT	Flange Excl. VAT
0.25	1440	71	14	R3,917	R4,194
0.37	1420	71	14	R4,340	R4,637
0.55	1450	80	19	R4,581	R4,942
0.75	1450	80	19	R5,156	R5,542
1.1	1435	90L	24	R5,722	R6,117
1.5	1440	90L	24	R6,740	R7,220
2.2	1450	100L	28	R8,230	R9,281
3	1440	112M	28	R9,406	R10,064
3.7	1430	112M	28	R11,862	R12,692
5.5	1440	132M	38	R15,457	R16,539
7.5	1460	132M	38	R17,867	R19,117

Note: Prices Exclude VAT.

Please check page 6 for the minimum requirements for accurate quotations and purchase orders

All prices and values are subject to change without prior notice. To obtain guaranteed values, please contact your nearest sales office.



WEG ELECTRONICALLY COMMUTATED MOTOR

IE5 Single Phase

WECM



Minimum info required for orders and enquires.

WEG EC Motor

kW	
Speed	
Voltage	
Mounting	

Motor + Drive Combo

Local or remotely controlled

Single Phase 220 to 277VAC, 50/60Hz

Overload, Over Temperature & Locked rotor Protection

Fire Mode (Override & Maximum Speed Mode)

WECM IE5 ALUMINIUM SINGLE PHASE MOTOR & DRIVE

220V

IP55

Description			Mounting	
kW	Speed r/min	Frame Size	Foot Excl. VAT	PAD Excl. VAT
0.12	3000	80	R3,785	R4,100
0.18	3000	80	R3,890	R4,200
0.25	3000	80	R3,995	R4,300
0.37	3000	80	R4,114	R4,409
0.55	3000	80	R4,249	R4,557
0.75	3000	80	R4,398	R4,698
1.1	3000	80	R5,047	R5,396

Description			Mounting	
kW	Speed r/min	Frame Size	Foot Excl. VAT	PAD Excl. VAT
0.12	1500	80	R3,732	R4,000
0.18	1500	80	R3,802	R4,100
0.25	1500	80	R3,917	R4,194
0.37	1500	80	R4,340	R4,637
0.55	1500	80	R4,581	R4,942
0.75	1500	80	R5,156	R5,542
1.1	1500	80	R5,722	R6,117

Note: Prices Exclude VAT.

Please check page 6 for the minimum requirements for accurate quotations and purchase orders

All prices and values are subject to change without prior notice. To obtain guaranteed values, please contact your nearest sales office



INTEGRATED ELECTRICAL SOLUTIONS

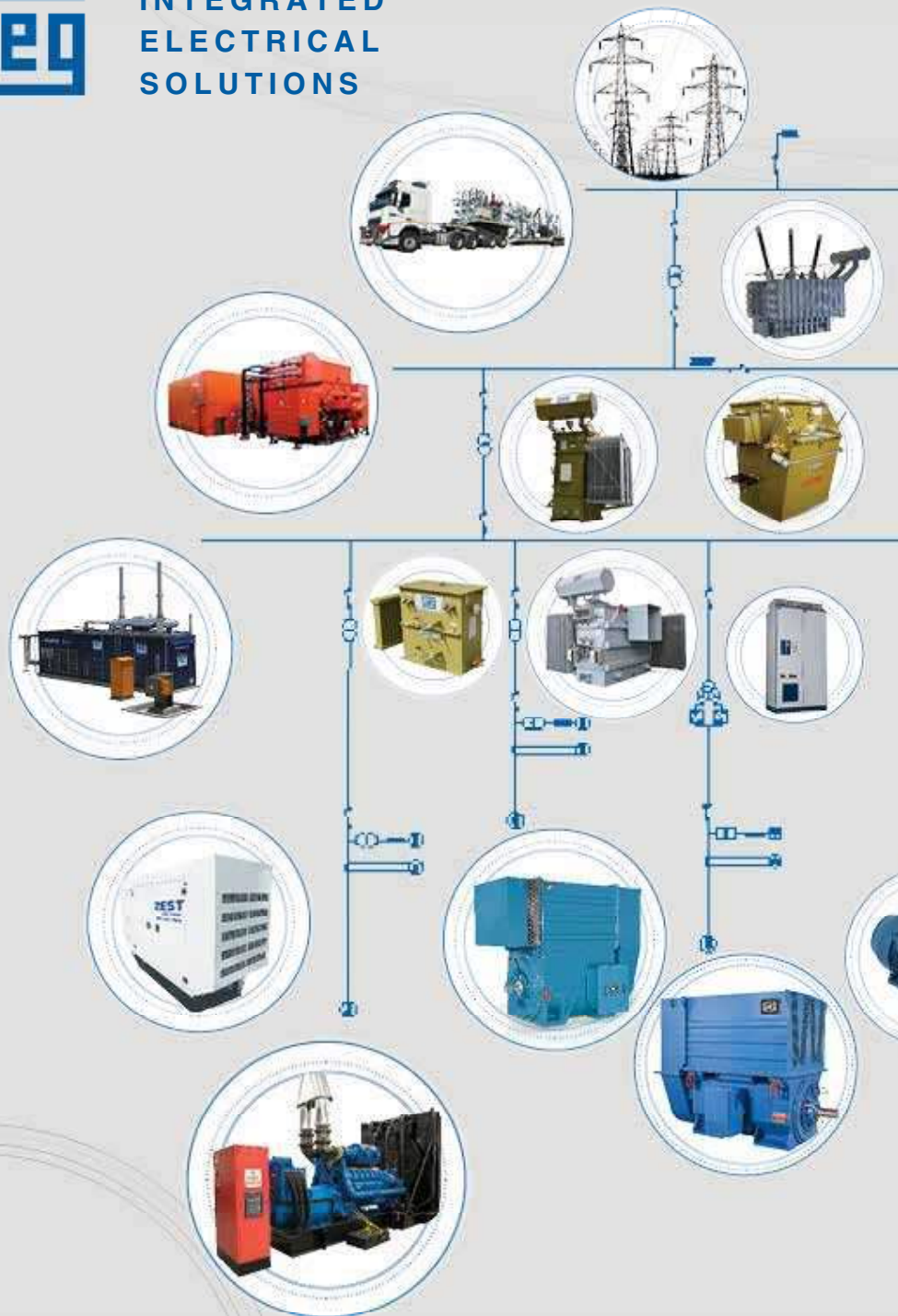

ZEST

WEG Group

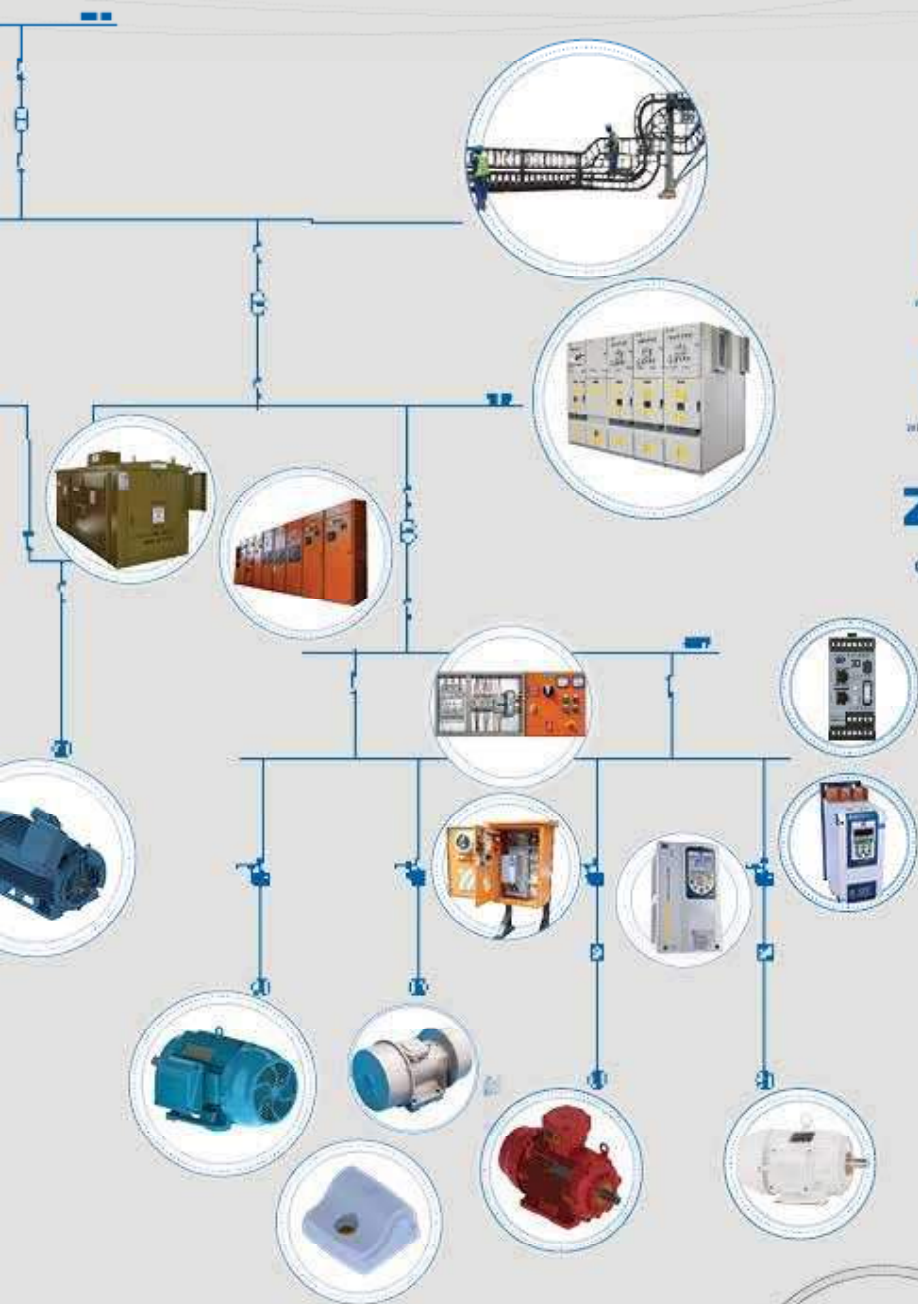

ZEST
WEG Group
Generator Sets



W22 (IE1 - 4)



WEEM



W22 WQuatro



W22 Brake Motor



W22 WWash



Slipring



W11
Aluminium



W22 Cooling Tower



W21
(Ex db)



W22X
(Ex db)



W22
(Ex nA) or (Ex tb)



W22 Smokex
Pad Mount



W20



W40 (ODP)



WMagnet



Direct Drive



HGF 500 - 630



W60



M Line





W21 Single Phase



Vibrator Motor



W22 2-Speed



W22 Roller Table



Saw Arbor



Gas Pump



W22 Smokex



W22 Pad Mount



W21 Pad Mount
Aluminium



MW500



W50



HGF ≤ 450



S Line



DC

THREE PHASE CAST IRON MOTOR

WWash IE3

W22

FOR USE IN HIGHLY HYGIENIC AND CLEAN ENVIRONMENTS



Minimum info required for orders and enquires.	
WWASH Motor IE3	
kW	
Speed	
Voltage	
Mounting	

IP66

Class H Insulation

Δ 220-240V or Y 380-415V 50Hz (63 to 100L)

Δ 380-415V or Y 660V 50Hz (112M to 200L)

or

Δ 525-550 V

Suitable for VSD

Oil seal with stainless steel spring (63 to 80 frame)

W3 seal (frame 90 to 200)

Space heater 230V

Shaft and hardware in stainless steel: AISI 316

Antimicrobial (anti-bacterial) paint: WEG NOBAC®

Colour RAL 9003

TEFC

TEAO on request

5 Year Guarantee on W22 Range

WWASH CAST IRON THREE PHASE MOTOR

Class H Insulation

380V / 400V / 415V or 525V / 550V

IP66

2 Pole				Mounting	
Description				Foot	Flange
kW	r/min	Volt	Frame	Excl. VAT	Excl. VAT
0.18	2860	400	63	R 4,510	R 5,715
0.25	2805	400	63	R 4,510	R 5,715
0.37	2820	400	71	R 4,904	R 6,123
0.55	2770	400	71	R 5,024	R 6,273
0.75	2850	400	80	R 5,792	R 7,258
1.1	2830	400	80	R 6,070	R 7,607
1.5	2875	400	90S	R 6,600	R 7,990
2.2	2865	400	90L	R 7,280	R 8,787
3	2910	400	100L	R 9,657	R 11,485
4	2900	400	112M	R 11,505	R 13,327
5.5	2940	400	132S	R 15,147	R 17,477
7.5	2935	400	132S	R 16,663	R 19,226
9.2	2935	400	132M	R 19,517	R 22,722
11	2950	400	160M	R 28,322	R 32,271
15	2945	400	160M	R 30,006	R 34,190
18.5	2945	400	160L	R 34,477	R 38,249
22	2950	400	180M	R 43,171	R 47,654
30	2965	400	200L	R 56,471	R 63,108
37	2960	400	200L	R 60,472	R 67,580

All prices and values are subject to change without prior notice.

To obtain guaranteed values, please contact your nearest sales office.



WWASH CAST IRON THREE PHASE MOTOR

Class H Insulation

380V / 400V / 415V or 525V / 550V

IP66

4 Pole				Mounting	
Description				Foot	Flange
kW	r/min	Volt	Frame	Excl. VAT	Excl. VAT
0.18	1370	400	63	R 4,510	R 5,715
0.25	1410	400	71	R 4,959	R 6,192
0.37	1385	400	71	R 5,134	R 6,411
0.55	1420	400	80	R 5,691	R 7,133
0.75	1430	400	80	R 5,840	R 7,319
1.1	1450	400	90S	R 6,328	R 7,660
1.5	1445	400	90L	R 7,089	R 8,556
2.2	1435	400	100L	R 8,977	R 10,676
3	1440	400	*L100L	R 10,049	R 11,950
4	1450	400	112M	R 12,729	R 14,745
5.5	1460	400	132S	R 16,427	R 18,953
7.5	1460	400	132M	R 18,383	R 21,402
9.2	1465	400	132M/L	R 21,998	R 25,611
11	1470	400	160M	R 29,812	R 33,969
15	1465	400	160L	R 31,691	R 35,158
18.5	1470	400	180M	R 42,278	R 46,668
22	1470	400	180L	R 45,365	R 50,076
30	1480	400	200L	R 57,195	R 63,917

6 Pole				Mounting	
Description				Foot	Flange
kW	r/min	Volt	Frame	Excl. VAT	Excl. VAT
0.25	955	400	71	R 5,555	R 6,936
0.37	925	400	80	R 5,763	R 7,222
0.55	945	400	*L80	R 6,012	R 7,534
0.75	950	400	*L90S	R 6,739	R 8,134
1.1	945	400	*L90L	R 7,163	R 8,646
1.5	955	400	100L	R 8,650	R 10,287
2.2	960	400	112M	R 11,712	R 13,567
3	970	400	132S	R 15,857	R 18,295
4	965	400	132M	R 17,217	R 20,045
5.5	965	400	132M/L	R 20,346	R 23,688
7.5	975	400	160M	R 29,035	R 33,083
9.2	975	400	160L	R 33,570	R 37,243
11	975	400	160L	R 35,416	R 39,291
15	975	400	180L	R 44,031	R 48,603
18.5	980	400	200L	R 56,776	R 63,449
22	980	400	200L	R 59,748	R 66,770

(*) Letter "L" means in accordance with IE 3 efficiency levels and increase in total length of motor.

Note: Prices Exclude VAT.

Please check page 6 for the minimum requirements for accurate quotations and purchase orders

EXTENDED GUARANTEES

on WEG Products

2 YEARS

WEG Variable Speed Drives and Soft Starters



5 YEARS

WEG W22 Motor Range



3 YEARS

WEG VSD or SS in Combination with WEG W22



3 YEARS

WEG Low Voltage Switchgear Motor



Please contact your nearest Sales office for further details





FLAME PROOF MOTOR

IE2 Premium Efficiency Plus

W22X



Minimum info required for orders and enquires.	
Flame Proof Motor	
kW	
Speed	
Voltage	
Mounting	
W21 Flameproof available on request	



IP66

Class H insulation for 550V

Class **F** insulation for 400V

Δ 220-240V or Y 380-415V 50Hz (71 to 100 frame)

Δ 380-415V or Y 660-690V 50Hz (112 to 355 frame)

or

Y 550V (71 to 100 frame)

Δ 550V or Y 950V (112 to 355 frame)

Temperature class T4

Ex db I T4 Mb

Ex db IIC T4

Thermistors 01/ Phase

Suitable for surface and underground

High voltage motors available on request

Certification: IECEX and local certification

IE3 available on request

Paint finish Red Munsell 7,5R 4/14

TEFC

Side terminal box on request

All prices and values are subject to change without prior notice.

To obtain guaranteed values, please contact your nearest sales office.

Please check page 6 for the minimum requirements for accurate quotations and purchase orders

THREE PHASE MOTOR FLAME PROOF IE2 PREMIUM EFFICIENCY W22X
 380V / 400V / 415V or 550V / 950V **IP66**

2 Pole				Mounting	
kW	r/min	Frame Size	Shaft Dia.(mm)	Foot Excl. VAT	Flange Excl. VAT
0.37	2805	71	14	R 9,042	R 9,518
0.55	2750	71	14	R 9,197	R 9,681
0.75	2850	80	19	R 9,823	R 10,340
1.1	2870	80	19	R 11,263	R 11,856
1.5	2840	90S/L	24	R 11,272	R 11,865
2.2	2840	90S/L	24	R 12,678	R 13,345
3	2880	100L	28	R 14,432	R 15,191
4	2890	112M	28	R 18,546	R 19,523
5.5	2935	132S/M	38	R 21,961	R 23,117
7.5	2920	132S/M	38	R 23,806	R 25,058
11	2945	160M/L	42	R 33,604	R 35,373
15	2945	160M/L	42	R 38,458	R 40,483
18.5	2945	160M/L	42	R 39,043	R 41,097
22	2950	180M/L	48	R 55,110	R 58,011
30	2965	200M/L	55	R 70,096	R 73,785
37	2965	200M/L	55	R 79,872	R 84,076
45	2965	225S/M	55	R 103,898	R 109,366
55	2965	250S/M	60	R 128,297	R 135,050
75	2965	250S/M	60	R 163,150	R 171,737
90	2975	280S/M	65	R 194,667	R 204,913
110	2975	280S/M	65	R 243,618	R 256,440
132	2970	315S/M	65	R 290,817	R 306,123
160	2970	315S/M	65	R 326,246	R 343,416

4 Pole				Mounting	
kW	r/min	Frame Size	Shaft Dia.(mm)	Foot Excl. VAT	Flange Excl. VAT
0.25	1380	71	14	R 9,411	R 9,906
0.37	1360	71	14	R 9,899	R 10,420
0.55	1410	80	19	R 10,390	R 10,937
0.75	1430	90S/L	19	R 11,111	R 11,696
1.1	1400	90S/L	24	R 11,486	R 12,091
1.5	1410	90S/L	24	R 12,023	R 12,656
2.2	1420	100L	28	R 13,940	R 14,674
3	1405	100L	28	R 14,432	R 15,191
4	1430	112M	28	R 16,672	R 17,549
5.5	1465	132S/M	38	R 25,408	R 26,745
7.5	1465	132S/M	38	R 27,900	R 29,368
11	1455	160M/L	42	R 36,215	R 38,122
15	1455	160M/L	42	R 41,286	R 43,459
18.5	1470	180M/L	48	R 54,739	R 57,620
22	1470	180M/L	48	R 58,626	R 61,711
30	1475	200M/L	55	R 74,383	R 78,298
37	1480	225S/M	60	R 89,309	R 94,010
45	1475	225S/M	60	R 96,866	R 101,964
55	1475	250S/M	70	R 120,270	R 126,599
75	1475	250S/M	70	R 145,293	R 152,940
90	1485	280S/M	80	R 180,282	R 189,770
110	1485	280S/M	80	R 204,299	R 215,052
132	1485	315S/M	85	R 256,946	R 270,468
160	1480	315S/M	85	R 267,689	R 281,778

Note: Prices Exclude VAT.

Please check page 6 for the minimum requirements for accurate quotations and purchase orders.



FLAME PROOF MOTOR IE2 PREMIUM EFFICIENCY W22X

380V / 400V / 415V or 550V / 950 V

IP66

6 Pole				Mounting	
kW	r/min	Frame Size	Shaft Dia.(mm)	Foot Excl. VAT	Flange Excl. VAT
0.18	845	71	14	R 9,380	R 9,874
0.25	845	71	14	R 10,048	R 10,576
0.37	895	80	19	R 10,246	R 10,786
0.55	910	80	19	R 10,905	R 11,479
0.75	920	90S/L	24	R 11,399	R 12,000
1.1	915	90S/L	24	R 13,686	R 14,407
1.5	940	100L	28	R 13,734	R 14,458
2.2	940	112M	28	R 16,031	R 16,874
3	960	132S/M	38	R 21,707	R 22,850
4	960	132S/M	38	R 23,964	R 25,225
5.5	960	132S/M	38	R 28,131	R 29,611
7.5	970	160M/L	42	R 36,308	R 38,219
11	970	160M/L	42	R 41,747	R 43,944
15	965	180M/L	48	R 57,426	R 60,448
18.5	975	200M/L	55	R 71,810	R 75,589
22	975	200M/L	55	R 75,431	R 79,402
30	985	225S/M	60	R 97,296	R 102,416
37	980	250S/M	70	R 109,673	R 115,444
45	980	250S/M	70	R 136,118	R 143,283
55	985	280S/M	80	R 169,316	R 178,227
75	985	280S/M	80	R 187,284	R 197,141
90	985	315S/M	85	R 222,078	R 233,766
110	985	315S/M	85	R 255,288	R 268,724

Note: Prices Exclude VAT.

FLAME PROOF W21 OR W22X - SPARE PARTS

Description	List Prices (Rands)													
	Frame Size													
	71	80	90	100	112	132	160	180	200	225	250	280	315	355
Terminal Box with Lid	-	-	-	-	-	-	9672	9636	9747	8061	8061	13024	23070	24574
Terminal Box Lid	680	680	864	1310	1480	1480	3668	3668	3668	2204	2204	3287	8582	8582
Terminal Block	349	349	349	349	516	516	848	848	1500	6056	6056	6496	6496	9124
Fan Cowl	848	499	550	1110	1170	1325	1732	1882	2830	2870	2870	6853	6853	9584
Fan 2 pole Cast Iron	1865	2003	3004	4661	2175	3435	2662	2388	3977	5019	5019	6152	6990	6990
Fan 2 pole Cast Iron	1865	2003	3004	4661	5935	7858	7257	7257	8982	10117	10117	12571	12571	20371
B5 Flange	-	2287	3442	3442	3795	5838	5872	6392	9340	12640	12882	17755	19533	23191
B14 Flange	1597	2120	2458	5367	5460	5641	-	-	-	-	-	-	-	-
Drive Endshield	1487	1603	1800	2200	2200	2437	4873	4943	5212	8716	9951	11198	17563	21762
Non - drive Endshield	1502	1597	2069	2388	2347	2633	4440	4588	5113	7014	7014	11235	16486	17166
DE Bearing Cap	-	-	1158	2069	2069	2069	2650	2650	2650	5248	5248	5900	7477	11782
NDE Bearing Cap	-	-	2105	2105	2105	2105	4636	4636	4636	7138	7138	7647	7647	7647

Note: Prices Exclude VAT.

When placing orders, please specify if the parts are for W21 or W22X Flame Proof Motors.



BRAKE MOTOR

IE3 Three Phase

W22



IP55

Class F insulation

Δ 220-240V or Y 380-415V 50Hz (63 to 100 frame) Δ380-415V or Y 660-690V-50Hz(112 to 160 frame)

Δ 460V – 60Hz (63 to 160 frame)

or

Δ 525-550V - 50Hz (63 to 160 frame)

Rated output: available up to 75kW

Suitable for VSD

Brake power supply voltage: 380V 415V or 525 -575V (50Hz)

220-240V (50 Hz) Micro switch optional

Paint finish RAL 6002

TEFC

Minimum info required for orders and enquires.

Brake Motor	
kW	
Speed	
Voltage	
Mounting	

HIGH TORQUE BRAKES

5 Year Guarantee on W22 Range

W22 BRAKE CAST IRON THREE PHASE MOTOR

Class F Insulation

380V / 400V / 415V or 525V / 550V

IP55

4 Pole			Mounting			
kW	r/min	Frame	Brake Power	Brake Torque	Foot	Flange
		Size	(W)	(Nm)	Excl. VAT	Excl. VAT
0.18	1370	63	20	4	R 7,759	R 8,167
0.25	1370	71	25	12	R 8,589	R 9,041
0.37	1370	71	25	12	R 12,801	R 13,475
0.55	1415	80	25	12	R 13,060	R 13,748
0.75	1410	80	25	12	R 13,904	R 14,636
1.1	1430	90S	33	23	R 14,242	R 14,992
1.5	1410	90L	33	23	R 14,645	R 15,416
2.2	1410	100L	40	46	R 16,786	R 17,669
3	1420	100L	40	46	R 18,617	R 19,597
4	1440	112M	53	60	R 22,966	R 24,175
5.5	1465	132S	56	125	R 28,865	R 30,385
7.5	1455	132M	85	125	R 33,744	R 35,520
9.2	1455	132M	85	125	R 44,803	R 47,161
11	1460	160M	85	235	R 49,281	R 51,875
15	1465	160L	85	235	R 53,270	R 56,074
Bridge Rectifier					R 1,777	
Brake Pads					R 292	

Note: Prices Exclude VAT.

Please check page 6 for the minimum requirements for accurate quotations and purchase orders.

All prices and values are subject to change without prior notice.

To obtain guaranteed values, please contact your nearest sales office.





INVICTA

Vibrator Motor



Minimum info required for orders and enquires.	
Invicta Vibrator Motor	
Footprint	
kW	
Speed	
Voltage	
Kgf	



Winston Olivier

+27 11 723 6210

+27 82 889 5756

WOlivier@zestweg.com

2 YEAR GUARANTEE ON INVICTA RANGE

IP66

Class F Insulation

Group 28 (Δ 380-415V or Y 660-690V)

Group 03 (Y 525-550V)

Centrifugal force 50kgf - 31 500kgf

Output Range 70W-12500W

S1 Duty

Zone 2

Zone 21/22

Mounting Options

B3 (foot/base) Vertical and Horizontal

B5 (flange) Vertical

Pneumatic B3 (foot/base) Vertical and Horizontal

Hydraulic B3 (foot/base) Vertical and Horizontal

All prices and values are subject to change without prior notice.

To obtain guaranteed values, please contact your nearest sales office.

Please check page 6 for the minimum requirements for accurate quotations and purchase orders.

INVICTA VIBRATOR MOTOR**Class F Insulation**
380V/400V/415V/690V**IP66**
525V/550V

	Model No.	Mounting	Output Rating Watt	Centrifugal Force kgf	Working Moment (x2) kg.cm.
2 Pole 2880 r/min					
IVBLZ03-1/2...	BLz03-1/2	Base	120	100	2.16
IVBLZ05-2/2	BLz05-2/2	Base	200	200	4.3
IVBLZ15-3.5/2	BLz15-3.5/2	Base	300	350	7.6
IVBLZ20-5/2	BLz20-5/2	Base	400	500	10.8
IVBLz22-5/2	BLZ22-5/2	Base	400	500	10.8
IVBLZ24-8/2	BLz24-8/2	Base	500	800	17.2
IVBLZ24-10/2	BLz24-10/2	Base	500	1000	21.6
IVBLz24-13/2	BLz24-13/2	Base	500	1300	28
IVBLz25-8/2	BLz25-8/2	Base	500	800	17.2
IVBLZ25-10/2	BLz25-10/2	Base	500	1000	21.6
IVBLZ25-13/2	BLz25-13/2	Base	500	1300	28
IVBLZ30-16/2	BLz30-16/2	Base	1100	1600	34.5
IVBLZ30-20/2	BLz30-20/2	Base	1100	2000	43.2
IVBLZ40-30/2	BLz30-40/2	Base	1500	3000	64.7
IVBLZ40-40/2	BLz40-40/2	Base	1500	4000	86.3
IVBLZ45-50/2	BLz45-50/2	Base	4000	5000	108
4 Pole 1440 r/min					
IVBLZ03-0.5/4	BLz03-0.5/4	Base	100	50	4.3
IVBLZ05-1/4	BLz05-1/4	Base	175	100	8.6
IVBLZ05-2/4	BLz05-2/4	Base	175	200	17.2
IVBLZ15-3/4	BLz15-3/4	Base	300	300	26
IVBLZ20-5/4	BLz20-5/4	Base	350	500	43.1
IVBLZ22-5/4	BLz22-5/4	Base	350	500	43.1
IVBLZ24-7.5/4	BLz24-7.5/4	Base	500	750	64.7
IVBLZ24-11/4	BLz24-11/4	Base	500	1100	94.9
IVBLZ24-14/4	BLz24-14/4	Base	500	1400	121
IVBLZ25-7.5/4	BLz25-7.5/4	Base	500	750	64.7
IVBLZ25-11/4	BLz25-11/4	Base	500	1100	94.9
IVBLZ25-14/4	BLz25-14/4	Base	500	1400	121
IVBLZ30-18/4	BLz30-18/4	Base	1150	1800	155
IVBLZ30-25/4	BLz30-25/4	Base	1150	2500	216
IVBLZ40-35/4	BLz40-35/4	Base	1800	3500	302
IVBLZ45-45/4	BLz45-45/4	Base	2685	4500	388
IVBLZ50-55/4	BLz50-55/4	Base	3350	5500	474
IVBLZ50-65/4	BLz50-65/4	Base	4800	6500	560
IVBLZ50-75/4	BLz50-75/4	Base	4800	7500	647
IVBLZ60-95/4	BLz60-95/4	Base	7750	9500	820
IVBLZ60-105/4	BLz60-105/4	Base	7750	10500	906
IVBLZ75-130/4	BLz75-130/4	Base	10250	13000	1122



INVICTA VIBRATOR MOTOR

Class F Insulation

380V/400V/415V/690V

IP66

525V/550V

	Model No.	Mounting	Output Rating Watt	Centrifugal Force kgf	Working Moment (x2) kg.cm.
6 Pole 960 r/min					
IVBLZ03-0.2/6	BLz03-0.2/6	Base	70	22	4.3
IVBLZ05-0.4/6	BLz05-0.4/6	Base	90	40	7.8
IVBLZ05-0.9/6	BLz05-0.9/6	Base	90	90	17.5
IVBLZ15-1.3/6	BLz15-1.3/6	Base	110	130	25.2
IVBLZ20-2.2/6	BLz20-2.2/6	Base	150	220	42.7
IVBLZ22-2.2/6	BLz22-2.2/6	Base	150	220	42.7
IVBLZ24-4/6	BLz24-4/6	Base	510	400	77.6
IVBLZ24-8/6	BLz24-8/6	Base	510	800	155
IVBLZ24-11/6	BLz24-11/6	Base	510	1100	213
IVBLZ25-4/6	BLz25-4/6	Base	510	400	77.6
IVBLZ25-8/6	BLz25-8/6	Base	510	800	155
IVBLZ25-11/6	BLz25-11/6	Base	510	1100	213
IVBLZ30-14/6	BLz30-16/4	Base	900	1600	1122
IVBLZ30-18/6	BLz30-18/6	Base	900	1800	349
IVBLZ30-23/6	BLz30-23/6	Base	900	2300	446
IVBLZ40-27/6	BLz40-27/6	Base	1800	2700	524
IVBLZ40-35/6	BLz40-35/6	Base	1800	3500	680
IVBLZ45-42/6	BLz45-42/6	Base	2310	4200	815
IVBLZ45-50/6	BLz45-50/6	Base	2310	5000	970
IVBLZ50-60/6	BLz50-60/6	Base	4000	6000	1164
IVBLZ50-75/6	BLz50-75/6	Base	4000	7500	1455
IVBLZ60-90/6	BLz60-90/6	Base	6200	9000	1746
IVBLZ60-105/6	BLz60-105/6	Base	6200	10500	2037
IVBLZ60-125/6	BLz60-125/6	Base	10000	12500	2425
IVBLZ75-150/6	BLz75-150/6	Base	10000	15000	2910
IVBLZ75-185/6	BLz75-185/6	Base	10000	18500	3589
IVBLZ78-165/6	BLz78-165/6	Base	10000	16500	3201
IVBLZ78-185/6	BLz78-185/6	Base	10000	18500	3589
IVBLZ80-230/6	BLz80-230/6	Base	12500	23000	4462
IVBLZ80-270/6	BLz80-270/6	Base	12500	27000	5238
IVBLZ80-315/6	BLz80-315/6	Base	12500	31500	6111
8 Pole 720 r/min					
IVBLZ30-7.5/8	BLz30-7.5/8	Base	500	750	259
IVBLZ30-10/8	BLz30-10/8	Base	500	1000	345
IVBLZ40-15/8	BLz40-15/8	Base	1100	1500	517
IVBLZ45-24/8	BLz45-24/8	Base	2000	2400	838
IVBLZ50-35/8	BLz50-35/8	Base	3300	3500	1207
IVBLZ50-45/8	Blz50-45/8	Base	3300	4500	1552
IVBLZ50-55/8	Blz50-55/8	Base	3300	5500	1897
IVBLZ60-65/8	BLz60-65/8	Base	4900	6500	2242
IVBLZ60-90/8	BLz60-90/8	Base	4900	9000	3105
IVBLZ75-124/8	BLz75-124/8	Base	7750	12400	4279
IVBLZ75-135/8	BLz75-135/8	Base	7750	13500	4658
IVBLZ75-150/8	BLz75-150	Base	7750	15000	5174
4 Pole 1440 r/min					
IVSWL25-9.6/4	SWL25-9.6/4	Flange	500	960	82.8
IVSWL40-35/4	SWL40-35/4	Flange	1800	3500	302
IVSFL20-5/4	SFL20-5/4	Flange	450	500	43.1

OPTIONAL FEATURES

List Prices (Rands) Including Fitment										
Frame Size	PT100 1/ Bearing c/w auxiliary box	PT100 2/Bearing c/w auxiliary box	Colour Change	Rain Canopy	Epoxy Paint	Cast Iron Fan	Heater c/w auxiliary box	IP56 (Pad Mount Only)	IP65 (Pad Mount Only)	Provision for Vibration Sensor 1/Bearing
Code	B	BB	C	D	E	F	H	IP56	IP65	L
63 - 71	-	-	1115	1526	2229	3287	5205	1627	1627	1982
80	-	-	1115	1526	2229	3403	5205	1651	1651	1982
90	-	-	1115	1526	2229	3551	5205	1651	1651	1982
100	-	-	1115	1650	2229	3551	5205	1687	1687	1982
112	-	-	1115	1873	2229	3551	5205	1687	1687	1982
132	6387	12775	1115	1873	2229	7814	5205	1687	1687	1982
160	6387	12775	1115	2275	2229	9891	6129	1693	1693	1982
180	6387	12775	1115	2450	2229	9243	6129	1794	1794	1982
200	6387	12775	1115	2671	2229	9243	6129	1896	1896	1982
225	6387	12775	1949	4828	3898	11111	7054	7305	7305	1982
250	6387	12775	1949	5521	3898	13436	7054	7305	7305	1982
280	6387	12775	1949	6908	3898	13436	7054	8507	8507	1982
315	6387	12775	1949	7093	3898	16359	7054	-	-	1982
355	6387	12775	1949	9169	3898	16359	7054	-	-	1982

Note: Prices are nett & exclude VAT.

List Prices (Rands) Including Fitment										
Frame Size	Provision for Vibration Sensor 2/Bearing	Shaft Brush	Routine Test	Thermistor c/w auxiliary box	2 x Thermistors c/w auxiliary box	Vibration Test	PT100 1/ Winding c/w auxiliary box	PT100 2/ Winding c/w auxiliary box	Tropicalization & Heater	Zone 21/22 & Zone 2 *
Code	LL	O	R	T	TT	V	W	WW	X	Z
63 - 71	3963	-	2681	4213	6807	2681	-	-	5353	1974
80	3963	-	2681	4213	6807	2681	-	-	5353	2007
90	3963	-	2681	4213	6807	2681	-	-	5353	2021
100	3963	-	2681	4213	6807	2681	-	-	5353	2058
112	3963	-	2681	4213	6807	2681	-	-	5353	2326
132	3963	-	4193	4213	6807	4193	-	-	5353	2487
160	3963	-	4193	4444	7038	4193	6339	12679	5584	3103
180	3963	-	4193	4444	7038	4193	6339	12679	5584	3625
200	3963	-	4193	4444	7038	4193	6339	12679	5584	4425
225	3963	3038	4193	5369	7450	4193	7264	14529	8177	15785
250	3963	3038	4837	5369	7450	4193	7264	14529	8177	17954
280	3963	3038	4837	5369	7450	4837	7264	14529	8177	18315
315	3963	3038	4837	5369	7450	4837	7264	14529	8177	20945
355	3963	3038	4837	5369	7450	4837	7264	14529	8177	27164

Note: Prices are nett & exclude VAT.

* Zone 21/22 & Zone 2 prices are for IE3 motors only.



SPARE PARTS FOR CAST IRON MOTORS

List Prices (Rands)															
Frame Size															
Description	63	71	80	90	100	112	132	160	180	200	225	250	280	315	355
Earth Stud	178	178	178	178	178	260	260	441	441	685	1977	1977	1977	1977	1977
Rain Canopy	625	625	625	625	717	884	884	1185	1318	1482	3100	3621	4661	4800	6356
Shaft Slinger	46	46	46	68	68	87	99	153	162	208	240	240	240	259	259
Auxiliary box	759	759	759	759	759	759	759	867	867	867	1300	1300	1300	1300	1300
Terminal box with Cover	504	504	504	671	671	947	947	1371	1371	2042	3393	3393	6227	9471	16027
Terminal block	315	315	315	315	315	468	468	771	771	1361	2521	2521	4808	4808	9314
Terminal box Adaptor	-	-	-	-	-	-	-	-	-	-	-	3129	3686	5123	6039
Fan cowl	222	222	222	242	313	363	501	1158	1419	2164	6387	6387	9814	9814	15256
Brake motor fan cowl	1560	1560	1560	1560	1560	1873	1873	3432	3432	5167	5167	-	-	-	-
Fan 2 pole (plastic)	58	63	71	71	109	109	109	109	109	162	540	-	-	-	-
Fan 4 pole (plastic)	58	63	71	71	162	177	222	222	222	242	668	668	801	801	-
Fan 2 pole (aluminium)	444	400	506	506	668	644	562	765	765	680	1381	1381	1676	1982	-
Fan 4 pole (aluminium)	444	561	707	935	935	1189	1189	1225	1225	1020	1683	1982	3898	6360	6360
Fan 2 pole (cast iron)	1679	1865	2003	3004	4661	2175	3435	2662	2388	3977	5019	5019	6152	6990	7690
Fan 4 pole (cast Iron)	1679	1865	2003	3004	4661	5935	7858	7257	7257	8982	10117	10117	12571	12571	20371
B5 flange	824	942	1248	1248	1761	1761	2490	5028	5028	6853	10752	13508	13508	18055	23244
B14 flange	864	864	1139	1325	1530	1548	2044	-	-	-	-	-	-	-	-
Drive endshield	266	293	353	392	541	719	991	-	-	-	-	-	-	-	-
Non - drive endshield	266	293	353	392	541	719	991	1645	2299	3096	4879	5755	7635	31758	38909
Drive & non-drive end V'Ring seal	32	32	36	36	36	36	41	41	51	53	-	-	-	-	-
Drive end oil seal	201	222	222	247	254	254	257	259	343	428	1052	1052	-	-	-
Non - drive end oil seal	201	222	222	247	254	254	257	259	343	428	1052	1052	-	-	-
Drive end W seal	-	-	-	-	-	-	-	-	-	-	809	836	894	-	-
Non-drive end W seal	-	-	-	-	-	-	-	-	-	-	809	836	894	0	0
Drive end W3 seal (labyrinth)	-	-	-	-	-	-	-	-	-	-	-	-	2521	3520	5115
Non - drive end W3 seal (labyrinth)	-	-	-	-	-	-	-	-	-	-	-	-	2521	3520	5115
Bearing cap sets for oil seal	-	119	119	218	305	410	468	480	589	562	3568	3568	3520	4365	5991
Bearing cap sets for W seal	-	-	-	-	-	-	-	-	-	-	2032	2032	2359	3035	4326
Bearing cap sets for W3 seal	-	-	-	-	-	-	-	-	-	-	5576	5576	8049	8049	8049

Prices exclude VAT.

V'Ring



W Seal



Oil Seal



W3 Seal



DIMENSIONS FOR W22 RANGE

Foot Mount

FRAMES 63 TO 132M/L

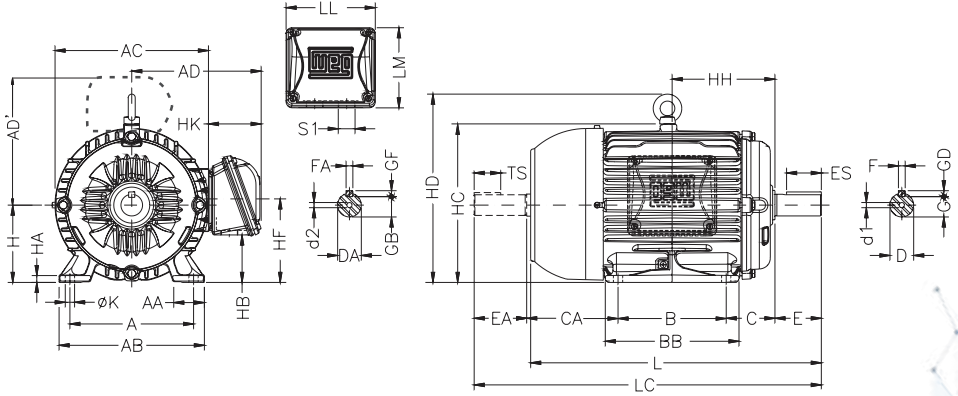

FRAMES 160M TO 200L

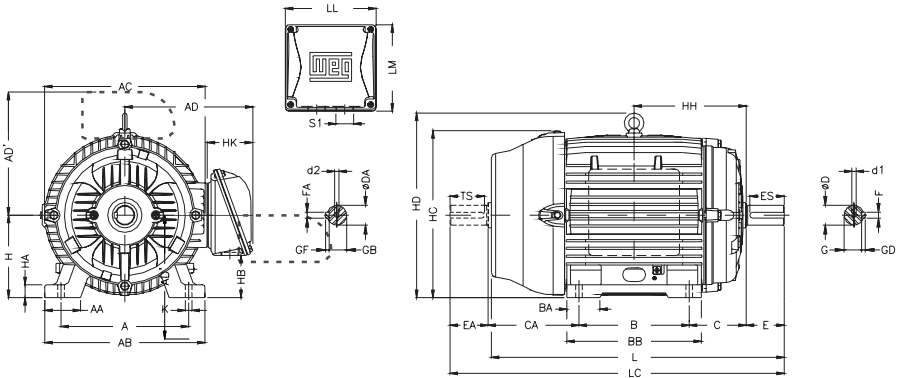

Frame	A	AA	AB	AC	AD	AD' (**)	B	BA	BB	BD	C	CA	Shaft												
													D	DA	E	EA	ES	F	FA	G	GB	GD	GF	TS	
63	100	25.5	116	125	123	123	80			95	40	78	11j6	9j6	23	20	14	4	3	8.5	7.2	4	3	12	
71	112	28.5	132	141	131	131	90			113.5	45	88	14j6	11j6	30	23	18	5	4	11	8.5	5	4	14	
80	125	30.5	149	159	140	140	100			125.5	50	93	19j6	14j6	40	30	28	6	5	15.5	11	6		18	
L80																									
90S																									
90L																									
L90S																									
L90L																									
100L	140	40	188	199	169	169	140			173	63	254													
L100L																									
112M																									
132S																									
132M																									
132M/L																									
160M	254	64	308	329	266	266	210	63	254	108	174	42k6	42k6												
160L																									
180M																									
180L																									
200M																									
200L																									
200L	318	82	385	402	319	319	305	82	370	133	222	55m6													
112M																									
132S																									
132M																									
132M/L																									

Frame	H	HA	HB	HC	HD	HF	HG	HH	HK	K	L	LC	LL	LM	S1	D1	D2	Bearings	
																		D.E	N.D.E.
63	63	7	25.5	130	68.5	76		80	59	7	216	241	108.5	99		EM4	EM3	6201 ZZ	
71	71		33	145				90			248	276				DM5	EM4	6202 ZZ	
80	80	8	43.5	163	87			100	10	10	276	313	108.5	99		DM6	DM4	6204 ZZ	6203 ZZ
L80								325			362	DM6				DM4	6204 ZZ	6203 ZZ	
90S	90	9	45	182	90			106	59	10	304	350	108	98	1xM20x1.5	DM8	DM6	6205 ZZ	6204 ZZ
90L								118.5			329	375							
L90S								106			335	381							
L90L								118.5			360	403							
100L								133			376	431							
L100L	100	10	61.5	205	244	106.4	133	1420	475	DM10	DM8	6206 ZZ	6205 ZZ						
112M	112		54.5	235	280	112	140	80	12	393	448	140	133	1xM25x1.5			6207 ZZ	6206 ZZ	
132S	132	16	75	274	319	132	159	80	12	452	519	140	133	2xM25x1.5	DM12	DM10	6308 ZZ	6207 ZZ	
132M							178			490	557								
132M/L							190.5			515	582								
160M	160	22	79	331	374	168	213	101	14.5	101	598	712	198.5	190	2xM32x1.5	DM16	DM16	6309 C3	6209 Z-C3
160L							235				642	756							
180M							241.5				664	782							
180L							260.5				702	820							
200M							266.5				729	842							
200L	200	30	119	407	464	218	285.5	119.5	18.5	767	880	230	220	DM20	DM20	6312 C3	6212 Z-C3		

*Dimension applicable to 2-pole motors

**Dimension applicable to top mounted terminal box

***For 185 kW and larger

Note: For IEC frames, the letter "L" means being in accordance with IE3 efficiency levels. This difference occurs due to the increase of the total length of the motor.

DIMENSIONS FOR W22 RANGE

Foot Mount

FRAMES 225S/M TO 355M/L

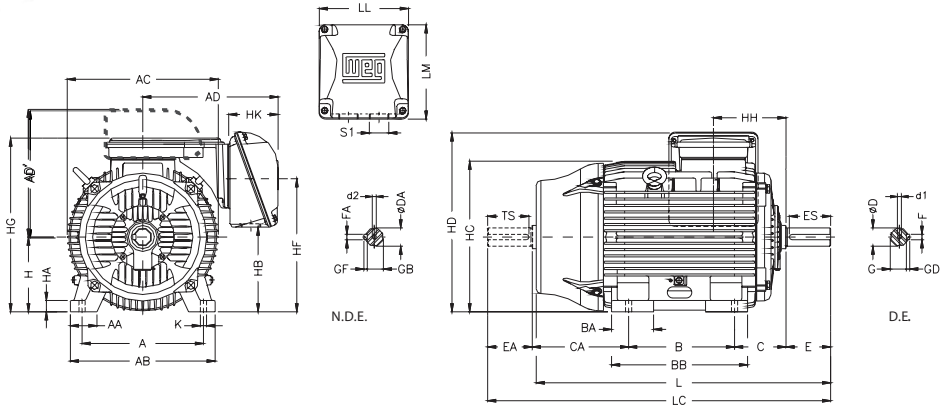

FRAME 355A/B

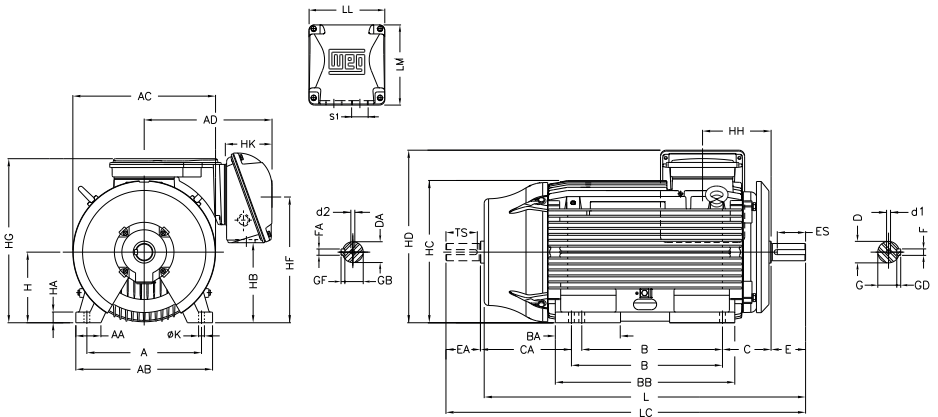

Frame	A	AA	AB	AC	AD	AD' (**)	B	BA	BB	BD	C	CA	Shaft											
													D	DA	E	EA	ES	F	FA	G	GB	GD	GF	TS
225S/M	356	80	436	455	410	384	286/311	124	412	41	149	319/294	55m6*	55m6*	110*	110*	100*	16*	16*	49*	49*	10*	10*	100*
													60m6	60m6	140	140	125	18	18	53	53	11	11	125
250S/M	406	100	506	486	410	402	311/349	146	467	59	168	354/316	60m6*	60m6	140	140	125	18*	20	53*	53	11*	12	125
													70m6	140										
280S/M	457	557	599	445	472	368/419	151	517	49	190	385/334	494/443	65m6*	60m6*	140*	140	125*	18*	18	58*	53*	11*	12	125
													80m6	65m6	170									
315S/M	508	120	630	657	525	530	406/457	184	621	70	216	502	65m6*	60m6*	140*	140	125*	18*	18	58*	53*	11*	12	125
315S/M (***)													85m6	65m6	170									
													70m6*	65m6	140*									
													90m6		170									
315L	589	575	508	219	752	81	502	70m6*	140*	125*	20*	62.5*	58	12*	14									
90m6								170	160	25	81	58	14											
355M/L	610	140	750	736	609	625	560/630	230	760	65	254	483/413	90m6*	60m6*	170*	140*	160*	25*	18*	81*	53*	14*	11*	125*
355A/B					701	725	710/800	325	955	70		528/438	100m6	80m6	210	170	200	28	22	90	71	16	14	160
355A/B	610	140	750	736	701	725	710/800	325	955	70	254	528/438	90m6*	60m6*	170*	140*	160*	25*	18*	81*	53*	14*	11*	125*
355A/B					701	725	710/800	325	955	70	528/438	100m6	80m6	210	170	200	28	22	90	71	16	14	160	

Frame	H	HA	HB	HC	HD	HF	HG	HH	HK	K	L	LC	LL	LM	S1	D1	D2	Bearings	
																		D.E	N.D.E.
225S/M	225	34	254	453	541	421	534	212	153	18.5	856*	974*	269	285	2xM32x1.5	DM20	DM20	6314 C3	
250S/M	250	43	297	493	583	463	577	214			24	965						1113	2xM40x1.5
280S/M	280	42	386	580	700	572	686	266	147	28	1071*	1223*	314	312	2xM50x1.5	DM20	DM20	6314 C3*	6314 C3*
315S/M	315	48		644	768	592	751	264	176		24	1244*	1392*	379	382			2xM63x1.5	DM20
315S/M (***)			1274	1426	404	436	2xM80x2	DM24	DM20	6316 C3*	6316 C3*								
315L			336	774						575	760	284	220	1353*	1501*	6316 C3*	6316 C3		
355M/L			355	50	461	898	700	885	340	290	1383	1536	404	436	2xM80x2	DM24	DM20	DM20	6319 C3*
355A/B	411	955			1442*	1607*					6319 C3*	6316 C3*							
355A/B	355	50	411	955	700	885	340	290	1482	1677	460	544	2xM80x2	DM24	DM20	DM24	NU-322 C3	6319 C3	
355A/B									1637*	1802*							6319 C3*	6316 C3*	
355A/B	355	50	411	955	700	885	340	290	1677	1872	460	544	2xM80x2	DM24	DM20	DM24	NU-322 C3	6319 C3	
355A/B									1677	1872							6319 C3*	6316 C3	

*Dimension applicable to 2-pole motors

**Dimension applicable to top mounted terminal box

***For 185 kW and larger

Note: For IEC frames, the letter "L" means being in accordance with IE3 efficiency levels. This difference occurs due to the increase of the total length of the motor.

DIMENSIONS FOR W22 RANGE

Pad Mount

FRAMES 80 TO 200L

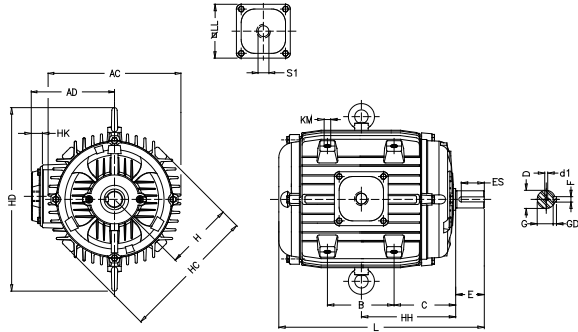

FRAMES 225S/M

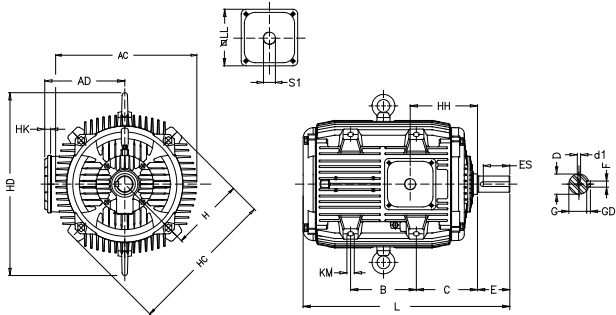

FRAME 250S/M

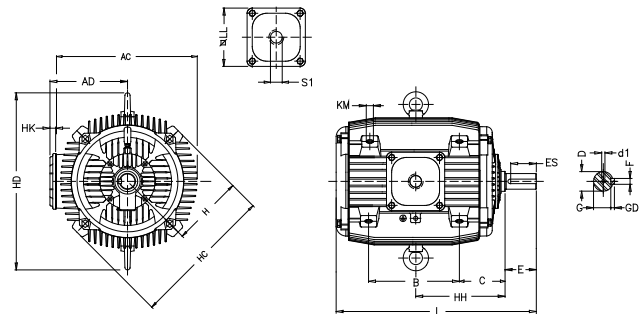



Frame	Front view						Left side view				
	AC	AD	H	HC	HD	HK	B	C	HH	KM	L
80	166	113	80	170	-	30	100	50	100	M12x1.75x18	238
L80	166	113	80	170	-	30	100	50	100	M12x1.75x18	287
90S	185	123	90	190	-	30	100	56	106	M12x1.75x18	258
L90S	185	123	90	190	-	30	100	56	106	M12x1.75x18	289
90L	185	123	90	190	-	30	125	56	118.5	M12x1.75x18	283
L90L	185	123	90	190	-	30	125	56	118.5	M12x1.75x18	314
100L	206	133	100	210	244	30	140	63	133	M12x1.75x18	322
L100L	206	133	100	210	244	30	140	63	133	M12x1.75x18	362
112M	215	160	112	234	280	45	140	70	140	M12x1.75x18	336
132S	260	188	132	290	319	45	140	89	159	M16x2x24	393
132M	260	188	132	290	319	45	178	89	178	M16x2x24	430
160M	319	193	160	364	380	25	210	108	213	M20x2.5x30	574
160L	319	193	160	364	380	25	254	108	235	M20x2.5x30	574
180L	360	208	180	366	413	25	279	121	260.5	M20x2.5x30	622
200L	380	221	200	434	464	18	305	133	285.5	M24x3x41	676
225S/M ¹	455	279	225	453	541	20	286/311	149	212	M24x3x45	727
225S/M	455	279	225	453	541	20	286/311	149	212	M24x3x45	761
250S/M ¹	486	279	250	493	583	20	311/349	168	214	M24x3x45	824
250S/M	486	279	250	493	583	20	311/349	168	214	M24x3x45	824

Frame	Entry plate detail		Shaft end detail						Bearing size	
	LL	S1	D	D1	F	F	G	GD	DE	NDE
80	80	M20x1,5	19j6	DM6	6	6	15.5	6	6204 ZZ	6203 ZZ
L80	80	M20x1,5	19j6	DM6	6	6	15.5	6	6204 ZZ	6203 ZZ
90S	80	M20x1,5	24j6	DM8	8	8	20	7	6205 ZZ	6204 ZZ
L90S	80	M20x1,5	24j6	DM8	8	8	20	7	6205 ZZ	6204 ZZ
90L	80	M20x1,5	24j6	DM8	8	8	20	7	6205 ZZ	6204 ZZ
L90L	80	M20x1,5	24j6	DM8	8	8	20	7	6205 ZZ	6204 ZZ
100L	80	M20x1,5	28j6	DM10	8	8	24	7	6206 ZZ	6205 ZZ
L100L	80	M25x1,5	28j6	DM10	8	8	24	7	6206 ZZ	6205 ZZ
112M	104	M25x1,5	28j6	DM10	8	8	24	7	6307 ZZ	6206 ZZ
132S	104	2xM25x1,5	38k6	DM12	10	10	33	8	6308 ZZ	6207 ZZ
132M	104	2xM25x1,5	38k6	DM12	10	10	33	8	6308 ZZ	6207 ZZ
160M	140	M32x1,5	42k6	DM16	12	12	37	8	6309 C3	6209 Z-C3
160L	140	M32x1,5	42k6	DM16	12	12	37	8	6309 C3	6209 Z-C3
180L	140	M32x1,5	48k6	DM16	14	14	42.5	9	6311 C3	6211 Z-C3
200L	155	M40x1,5	55m6	DM20	16	16	49	10	6312 C3	6212 Z-C3
225S/M ¹	196	M50x1,5	55m6	DM20	16	16	49	10	6314 C3	6314 C3
225S/M	196	M50x1,5	60m6	DM20	18	18	53	11	6314 C3	6314 C3
250S/M ¹	196	M63x1,5	60m6	DM20	18	18	53	11	6314 C3	6314 C3
250S/M	196	M63x1,5	65m6	DM20	18	18	58	11	6314 C3	6314 C3

Notes: 1) Dimensions for 2 pole motors.

DIMENSIONS FOR W22 RANGE

Flange Mount

“FF” FLANGE (B5)

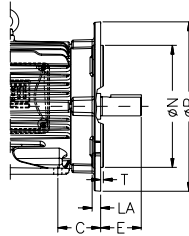
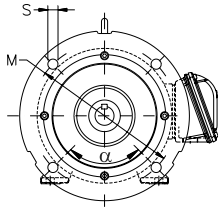

Flange “FF”									
Frame	Flange	LA	M	N	P	S	T		N° of holes
63	FF-115	9	115	95	140	10	3	45°	4
71	FF-130		130	110	160		3.5		
80	FF-165	10	165	130	200	12	4		
90									
100	FF-215	11	215	180	250	15	5		
112	FF-265								
132	FF-265	12	265	230	300	19	5		
160	FF-300	18	300	250	350				
180	FF-350					350	300		
200	FF-400	18	400	350	450	19	5		
225	FF-500							500	450
250	FF-500	18	500	450	550	19	5	22°30'	8
280									
315	FF-600	22	600	550	660	24	6		
355	FF-740								

“C-DIN” Flange (B14)

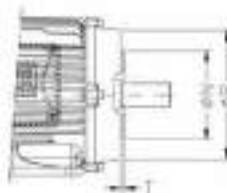
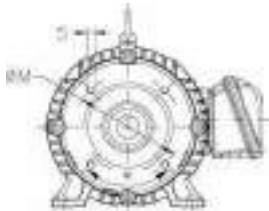

Frame	Flange	B14 Small					T		N° of Holes	B14 Large			
		M	N	P	S	M				N	P	S	
63	C-90	75	60	90	M5	2,5	45°	4	100	80	120	M6	
71	C-105	85	70	105	M6				115	95	140	M8	
80	C-120	100	80	120		3			130	110	160		
90	C-140	115	95	140	M8				3,5	165	130	200	M10
100	C-160	130	110	160		M10				215	180	250	
112	C-160												
132	C-200	165	130	200	M10								



DIMENSIONS FOR W22 FANS

IE1 & IE3



IE1																			
Poles	Frame	63	71	80	90S	100	112	132	160	180	200	Pole	225	250	280	315S/M	315L	355M/L	355A/B
2 Pole	Outside diameter D(mm)	109 - 110	120 - 126	132 - 140	132 - 140	175 - 182	150	170	150 - 156	150 - 156	175	2 Pole	190 - 194		212 - 225	234 - 242		265	
	Hub diameter d (mm)	10	12	15	15	15	23	28	30	44	50		65		65	65		65	
	Width L(mm)	16-17	22-25	23-25	23-25	36-40	37-38	39-40	42-47	47	55-58		66 - 87		66 - 83	66 - 92		102	
4 Pole	Outside diameter D(mm)	109 - 110	120 - 126	132 - 140	132 - 140	175 - 182	190 - 200	230 - 237	230	230	260	4 Pole	395 - 312		312 - 335	312 - 335	420		
	Hub diameter d (mm)	10	12	15	15	15	23	28	30	44	50		65		65	65	65		
	Width L(mm)	16-17	22-25	23-25	23-25	36-40	37-38	40-42	47	47	58		77 - 115		77 - 105	77 - 105	134		
6 - 8 Pole	Outside diameter D(mm)	109 - 110	120 - 126	132 - 140	132 - 140	175 - 182	190 - 200	230 - 237	230	230	230	6 - 8 Pole	295 - 312		312 - 335	312 - 335	420	511	
													65		65	65	65	65	
													77 - 115		77 - 105	77 - 105	134	126	

IE3																			
Poles	Frame	63	71	80	90S	100	112	132	160	180	200	Pole	225	250	280	315S/M	315L	355M/L	355A/B
2 Pole	Outside diameter D(mm)	109 - 110	120 - 126	132 - 140	132 - 140	175 - 182	110	170	150 - 156	150	175	2 Pole	190 - 194		212 - 225	234 - 242		265	
	Hub diameter d (mm)	10	12	15	15	23	28	28	44	50	55		65		65	65		65	
	Width L(mm)	16-17	22-25	23-25	23-25	36-40	37-38,5	37-38	42-47	45-47	55-58		66 - 81		66 - 83	66 - 92		102	
4 Pole	Outside diameter D(mm)	109 - 110	120 - 126	132 - 140	132 - 140	175 - 182	150	170	150 - 156	150	175	4 Pole	212 - 225		295 - 312	312 - 335	312 - 335	420	
	Hub diameter d (mm)	10	12	15	15	23	28	30	44	50	55		65	65	65		65	65	65
	Width L(mm)	16-17	22-25	23-25	23-25	36-40	37-38	39-40	42-47	45-47	55-58		77 - 115		77 - 105	77 - 105	134		
6 - 8 Pole	Outside diameter D(mm)	109 - 110	120 - 126	132 - 140	132 - 140	175 - 182	190 - 200	230 - 237	230	230	230	6 - 8 Pole	295 - 312		312 - 335	312 - 335	420	511	
	Hub diameter d (mm)	10	12	15	15	23	28	30	44	50	55		65		65	65	65	65	
	Width L(mm)	16-17	22-25	23-25	23-25	36-40	37-38	40-42	42-47	47	58		77 - 115		77 - 105	77 - 105	134	126	

SLIDE RAILS

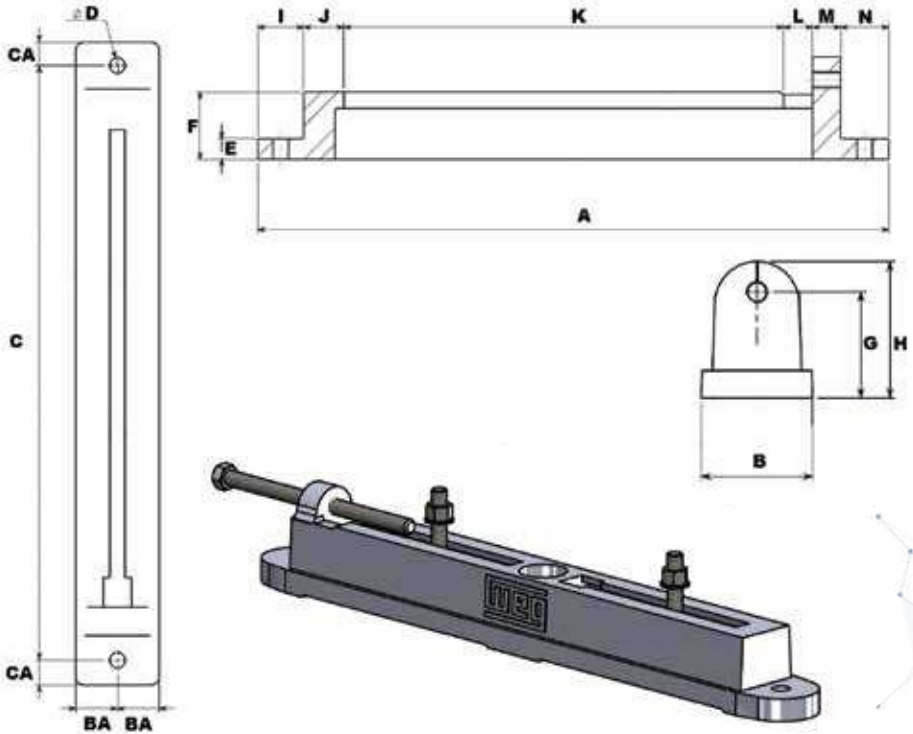

SLIDE RAILS

	A	B	BA	C	CA	D	E	F	G	H	I	J	K	L	M	N	List Price (per pair)
80/90	355	35	18	325	10	10	12	30	36	55	38	14	235	148	19	38	R 4,473
100/112/132	470	52	25	430	20	12	16	44	50	70	38	17	325	24	20	38	R 5,309
160/180	615	78	38	565	25	15	19	64	74	100	50	21	435	32	28	50	R 8,472
200/225	785	104	50	725	30	19	25	82	94	125	56	48	550	56	35	58	R 12,428
250/280	985	100	50	885	40	24	30	100	111	145	77	25	710	40	37	68	R 14,757
315/355	1215	120	60	1115	50	26	40	125	145	180	65	20	925	50	42	68	R 26,140

Note: Prices Exclude VAT.

Please check page 6 for the minimum requirements for accurate quotations and purchase orders.



HIGH VOLTAGE

Motors

For project specific motors and special designs please contact our Proposals Department zpq@zestweg.com



W50 MOTOR LINE

TEFC Squirrel Cage
Frame 315 to 450
110kW to 1250kW



W60 MOTOR LINE

Squirrel Cage
Frames 450 to 900
315kW to 11200 kW
Larger or custom designed motors
available on request

Type of cooling

Air to Air Cooler
Air to Water Cooler
Open Drip Proof



TECHNICAL INFORMATION

Standard Connection Diagram For Auxiliary Equipment

AUXILIARY TERMINAL BOX

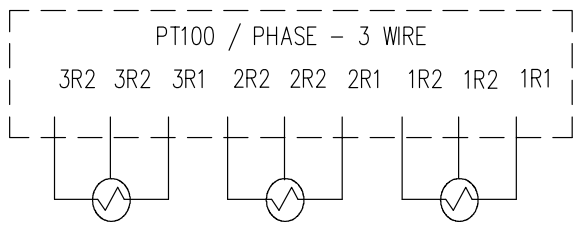

DRIVE END BEARING

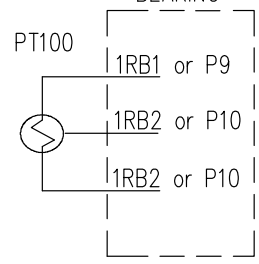

NON DRIVE END BEARING

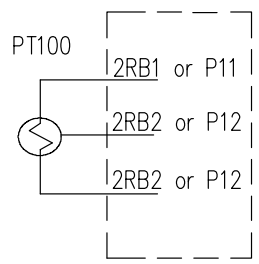

WINDING THERMISTOR

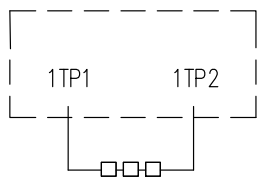

SPACE HEATERS

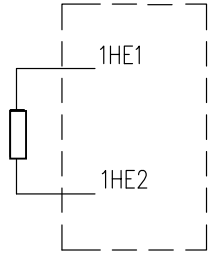

TECHNICAL INFORMATION

Typical WEG terminal Connections 3 Phase Motors

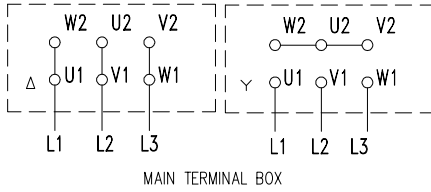

Multivoltage motors	Δ Delta	Y Star
Frame 63 -100	Δ 220-240V	Y 380-415V
or	Δ 525-550V	Y 1000V
Frame 112 -355	Δ 380-415V	Y 660-690V
or	Δ 525-550V	Y 1000V

Single Phase Motors

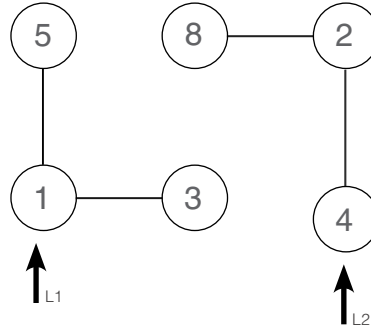

Join leads: 1, 3 and 5 together and supply incoming Line 1 to these three.

Join leads: 2, 4 and 8 together and supply incoming Line 2 to these three.

To reverse direction, interchange leads 5 and 8

BRAKING SYSTEM

The W22 brake motor allows two braking speeds: normal braking or fast braking.
Brake power supply connection terminal 1 and 2

Normal braking

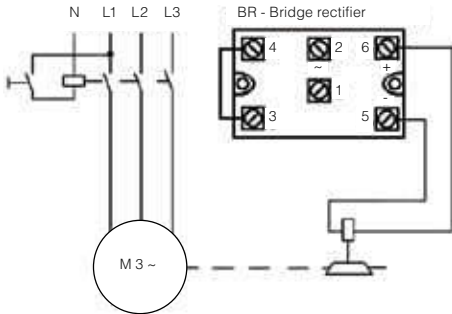

Connection Diagram of the bridge rectifier for normal braking

Fast braking

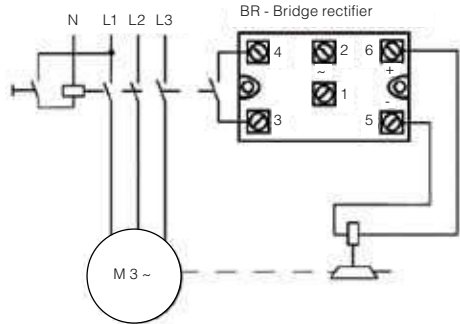

Connection Diagram of the bridge rectifier for fast braking

THERMAL CLASSES

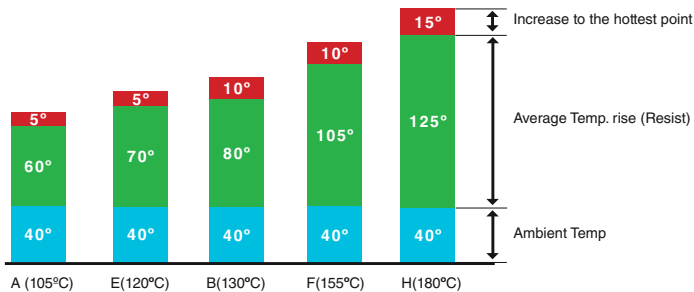

FORMULAE

$$\text{Demand Savings kW} = \frac{\text{Output}_{(IE1)}(\text{kW})}{\left(\frac{\text{Efficiency}_{(IE1)}(\%)}{100}\right)} - \frac{\text{Output}_{(IE3)}(\text{kW})}{\left(\frac{\text{Efficiency}_{(IE3)}(\%)}{100}\right)}$$

$$\text{Annual Energy Savings kWh} = \text{Demand Savings kW} \times \text{Operating days} \times \text{Operating hours}$$

$$\text{Annual Savings (R)} = \text{Annual Energy Savings kWh} \times \text{Energy Cost R/kWh}$$

$$\text{HP to kW: } \text{kW} = \text{HP} \times 0.7457$$

$$\text{Input Power (3 Phase): } P(\text{elec})\text{kW} = \frac{1.732 \times V(\text{line}) \times I(\text{line}) \times \text{COS}}{1000}$$

$$\text{Output Power (3 Phase): } P(\text{mech})\text{kW} = \frac{P(\text{elec}) \times \uparrow(\text{efficiency})}{100}$$

$$\text{Efficiency: } \uparrow(\%) = \frac{P(\text{mech})\text{kW}}{P(\text{elec})\text{kW}} \times 100$$

$$\text{Current (3 Phase): } I(\text{rated})\text{A} = \frac{P(\text{elec})\text{kW} \times 1000}{1.732 \times V(\text{line}) \times \text{COS}}$$

$$I(\text{rated})\text{A} = \frac{S(\text{kVA}) \times 1000}{1.732 \times V(\text{line})}$$

$$\text{Synchronous Speed: } \text{Synchronous}(r/\text{min}) = \frac{\text{Frequency}(\text{Hz}) \times 120}{\text{Poles}}$$

$$\text{Rated Slip: } \text{Slip}(\%) = \frac{\text{Synchronous}(r/\text{min}) - \text{Rated}(r/\text{min})}{\text{Synchronous}(r/\text{min})} \times 100$$

$$\text{Torque: } T(\text{rated})\text{Nm} = \frac{P(\text{mech})\text{kW} \times 9550}{\text{Speed}(r/\text{min})}$$

$$P(\text{mech}) = \frac{T(\text{rated})\text{Nm} \times \text{Speed}(r/\text{min})}{9550}$$

$$\text{Torque related to load} = \frac{2 \times \pi \times n \times T}{60}$$



GLOBAL PRODUCT CERTIFICATIONS



GLOBAL



SOUTH AFRICA



ARGENTINA



AUSTRALIA



BRAZIL



CHINA



COLUMBIA



EUROPE



FRANCE



GERMANY



INDIA



ITALY



KOREA



MEXICO



NIGERIA



NORTH AMERICA



RUSSIA



SAUDI ARABIA

WWW.ZESTWEG.COM

Downloads & Tools



Along with all of our downloadable product brochures, a library of interesting articles in the news and the WEG product training we have on offer, we have made the following available for your convenience online:

IE1, IE2, IE3 & IE4 MOTOR DATA SHEETS, CURVES AND DRAWINGS

2D AND 3D CAD LIBRARY

Drawings available in the following formats:

.dxf .iges .sat (ACIS) .step and .xt (Parasolid)

SOFTWARE TOOLS:

Electric Motor Selection Tool
Switchgear Part Selection Tool

AVAILABLE FROM YOUR SALES ENGINEER:

Harmonic Calculation Software
VSD Pump and Fan Energy Savings
Run-Up or acceleration time Calculation software
VSD Application Motor Selection Software

For special applications or non-standard conditions contact our Proposals Engineers for custom engineered solutions.



GROUP COMPANY

Contact Details

ZEST WEG GROUP GHANA LTD

15 Third Close Street
Airport Residential Area
Accra, Ghana
GPS: N 5° 36' 54.90" W 0° 10' 50.02"
Tel: +233 30 27 664 90
Cell: +233 540 898 466
ghana@zestweg.com

ENI ELECTRICAL

Electrical/Instrumentation Engineering
and Contracting
47 Galaxy Avenue
Linbro Business Park
GPS: S 26° 4' 10.92" E 28° 6' 45.88"
Tel: +27 (0) 11 792 2803
info@eni.zestweg.com

ZEST WEG GROUP GENERATOR SETS

CAPE TOWN

13 Benbow Avenue
Epping Industrial 1
GPS: S 33° 55' 48.65" E 18° 32' 12.6"
Tel: +27 (0) 21 507 7200
gensets@zestweg.com

JOHANNESBURG

47 Galaxy Avenue
Linbro Business Park
GPS: S 26° 4' 10.92" E 28° 6' 45.88"
Tel: +27 (0) 11 723 6000
gensets@zestweg.com

WEG AUTOMATION AFRICA

Low and Medium Voltage Packaged Switchgear Solutions
18 Mount Ida Road, Robertsham
Linbro Business Park
GPS: S 26° 14' 43.8" E 28° 00' 59.3"
Tel: +27 (0) 11 434 8100
waa@zestweg.com

WEG TRANSFORMERS AFRICA

Locally Manufactured Transformers and Mini-Substations,
Transformer Services and Repairs
[WADEVILLE](#)
3B Van Deventer Street
Waderville, Germiston
GPS: S 26° 15.941' E 28° 12.46'
Tel: +27 (0) 11 827 3458
wta@zestweg.com

HEIDELBERG

11 Marconi Street
GPS: S 26° 31' 7.54" E 28° 21' 33.28"
Tel: +27 (0) 16 349 2683/4/5
wta@zestweg.com
wta@zestweg.com

NATIONAL DISTRIBUTOR

Contact Details



GEORGE

BEARING & ALLIED

Cnr Albert and Foundry Street
George Industria
George, 6536
Tel: 044 874 1318
Fax: 044 874 1379

KIMBERLEY

LECFLO CC

P.O. Box 1408 Kimberley, 8301
2 Faraday Street
Ashburnham
Tel: +27 (0) 53 841 0378
Fax: +27 (0) 53 841 0379

KLERKSDORP

INTECH SERVICES CC

P.O. Box 6844 Flamwood 2572
32 Mahogany Street
Klerkindustria
Tel: +27 (0) 18 462 1792/3
Fax: +27 (0) 18 462 9260

LICHTENBURG

LICHTENBURG TECHNICAL SERVICES CC

P.O. Box 2048 Lichtenburg 2740
31 Melville Street
Lichtenburg
Tel: +27 (0) 18 632 1531
Fax: +27 (0) 18 632 1538

NELSPRUIT

SIZONKE TRADING (PTY) LTD

P.O. Box 1577 Nelspruit, 1200
12 Suikerriet Street
Nebo Park, Extension 12
Tel: +27 (0) 13 755 3188
Fax: +27 (0) 13 755 3195

NEWCASTLE

FORCE ELECTRICAL CC

P.O. Box 16009 Newcastle 2940
7 Edison Street, Newcastle
Tel: +27 (0) 34 375 7150
Fax: +27 (0) 34 375 7153

PHALABORWA

NORTHLITE ELECTRICAL WHOLESALERS

P.O. Box 1337
Phalaborwa, 1390
12 Leyd Street, Phalaborwa
Tel: +27 (0) 15 781 1545/2662
Fax: +27 (0) 15 781 0961

POLOKWANE

NORTHLITE ELECTRICAL WHOLESALERS

P.O. Box 2373
Polokwane, 0700
52 President Kruger Street
Polokwane
Tel: +27 (0) 15 291 1864/5
Fax: +27 (0) 15 291 1293

POLOKWANE

TWIN DRILLING AND TESTING CC

2 Michelle Crescent
Industrial Park
Polokwane 0787
Tel: +27 (0) 15 296 0372
Fax: +27 (0) 86 299 0746

ROBERTSON

JA IMMELMAN

9 Addeley Street
Robertson, 6705
Tel: +27 23 626 6910
Fax: +27 23 626 6910

TZANEEN

TZANEEN REWINDERS

Kew Street
Tzaneen 0850
Tel: +27 (0) 15 307 6570
Fax: +27 (0) 15 307 4122

VEREENIGING

NOBLE MOTOR AND CONTROL (PTY) LTD

P.O. Box 1490
Vereeniging 1930
Cnr Harrington and Houtkop Street
Duncanville
Tel: +27 (0) 16 427 4060
Fax: +27 (0) 16 427 2866

VIVO

THIDIKO (PTY) LTD

P.O. Box 175, Dendron, 0715
Kerk Street 230, Dendron, 0715
Tel: +27 (0) 72 719 6366
Email: Thidiko1@gmail.com
Fax: +27 (0) 44 884 1930



ZEST WEG GROUP AFRICA DISTRIBUTORS

Contact Details

In addition to its own network of distributors throughout South Africa
ZEST WEG Group is represented in the following African countries.

SOUTH AFRICA

AFRICA BUSINESS

DEVELOPMENT

Tel: +27 11 723 6000
Taylor Milan - Africa Business
Development Executive
Tel: +27 82 941 6181
Russell Finch - Sales Manager
Africa
Tel: +27 83 649 1431

ANGOLA

NOVA SOTECMA

Av. Deolinda Rodrigues 399
Tel: +244 932 405 507
Tel: +244 912 501 739

Bairro da Luz - Em frente ao
Tel: +244 945 352 526

Estrada Viana-Calumbo
Viana Park
Tel: +244 941 454 223

BOTSWANA

SEAPRO

Plot 72
Tlokweng
Gaborone
Botswana
Tel: +267 397 4861

VEREC

Unit 1 - Plot 170, Gaborone Int
Commerce Park
Gaborone, South East
Botswana
Tel: +267 390 8919

ESWATINI

VIVA ELECTRICAL

Commercial Centre
Simunye Str.
Matsapha
Tel: +268 251 84 402

IVORY COAST

RMS

Williamsville face garage de
la police
02 BP 809 Abidjan 02
Ivory Coast
Tel: +225 20 38 66 35

KENYA

REPELECTRIC KENYA LTD

Off Baba Dogo Road
Ruaraka
Kenya
Tel: +254 733 333999

MADAGASCAR

ARIS TRADING

Lot VB 72 Z HB
Ambatoroka
101 - Antananarivo
Madagascar
Tel: +261 20 22 290 24

MALI

VENISE

Marche Dibida
Bamako
Mali
Tel: +233 66 15 58 59
+233 76 35 33 43

MAURITANIA

INTEQ MAURITANIA

Immeuble Océan Km1,
Rte de plage
Nouakchott
Mauritania
Tel. + 222 46 85 27 37

MAURITIUS

EMINEO LIMITED

Highlands, Phoenix, Mauritius
Tel: +230 698 8200

MOZAMBIQUE

TECNEL

Av. das Industrias, Parcela 760
C.P.:99 - Machava
Maputo, Mozambique
Work tel:+258 (21) 75 10 32

NAMIBIA

WALFISH ELECTRIC

109 Hage Geingob Str
Walvis Bay
Tel: +264 64 205 891

Unit 1 Edison Str
Swakopmund
Tel: +264 64 417 010

Ndilimani Cultural Troupe Str
Tsumeb
Tel: +264 67 225 000

NIGERIA

BEAMCO

3 Solomon Agbontan Rd, Apapa
Lagos
Nigeria
Tel: +234 803 22 23 999
+961 13 07 000 (Lebanon)

SENEGAL

INTEQ SENEGAL

SN Yoff Mbenguene
Route de l'aéroport
26695 Dakar
Sénégal
Tel: +221771204342

TANZANIA

MAGARE COMPANY LIMITED

2nd Floor, Office No. F214
Kirumba Valley
Mwanza
Tel: +255 28 298 1121

UGANDA / RWANDA

BEAUTIFUL ENG. & EQUIP

Katalemwa, 5.5 miles
Gayaza Road
Kampala, Uganda
Tel.: +256 414 663 360

PO Box 7374
Kigali, Rwanda
Tel.: +250 781 575 087

ZAMBIA

E C MINING LIMITED

Plot 5293 / 5294
Tanganyika Road
Off Mutentemuko Road
Heavy Industrial Area
Zambia
Tel: +260 212 210642
Tel: +260 212 210511
Tel: +260212 211518

POWERSPEED ELECTRICAL

Plot 7251 - Mukatasha Road
Light Industrial Road
P.O. Box 34373
Lusaka
Tel: +260 211 288158

ZIMBABWE

POWERSPEED ELECTRICAL

Kelvin Road North
Graniteside
Harare
Tel: +263 4 771097/8/9

MINGAMORNING INVESTMENTS

2 Wilcandia Street
Kwekwe
Tel: +263 552 52 5717

BLUETEK

285 Samora Machel
Eastlea
Harare
Tel: +263 474 7749

ZEST WEG GROUP GHANA LTD

15 Third Close Street
Airport Residential Area
Accra, Ghana
GPS: N 5° 36' 54.90" W 0° 10' 50.02"
Tel: +233 30 27 664 90





ZEST
WEG Group



www.zestweg.com | 0861 00 9378