

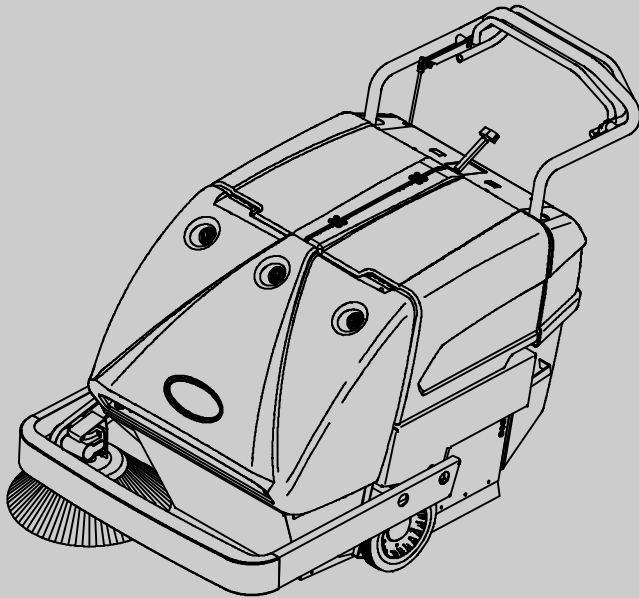

# S10

(Electric)

## Sweeper Operator Manual





This manual is furnished with each new model. It provides necessary operation and maintenance instructions.

**Read this manual completely and understand the machine before operating or servicing it.**

This machine will provide excellent service. However, the best results will be obtained at minimum costs if:

- The machine is operated with reasonable care.
- The machine is maintained regularly - per the machine maintenance instructions provided.
- The machine is maintained with manufacturer supplied or equivalent parts.

	<b>PROTECT THE ENVIRONMENT</b> Please dispose of packaging materials, old machine components such as batteries, hazardous fluids such as antifreeze and oil, in an environmentally safe way according to local waste disposal regulations.  Always remember to recycle.
	

<b>MACHINE DATA</b>	
Please fill out at time of installation for future reference.	
Model No. -	_____
Serial No. -	_____
Machine Options -	_____
Sales Rep. -	_____
Sales Rep. phone no. -	_____
Customer Number -	_____
Installation Date -	_____

**Tennant Company**

PO Box 1452

Minneapolis, MN 55440

Phone: (800) 553-8033 or (763) 513-2850

[www.tennantco.com](http://www.tennantco.com)

Thermo-Sentry is a US registered and unregistered trademark of Tennant Company.

Specifications and parts are subject to change without notice.

Original instructions, Copyright © 2007, 2009, 2010 TENNANT, Printed in U.S.A.

**CONTENTS**

	Page		Page
SAFETY PRECAUTIONS .....	2	BRUSHES .....	26
OPERATION .....	4	MAIN BRUSH .....	26
MACHINE COMPONENTS .....	4	REMOVING THE MAIN BRUSH ...	26
SYMBOL DEFINITIONS .....	5	INSTALLING THE MAIN BRUSH ..	26
CONTROLS AND INSTRUMENTS .....	6	CHECKING AND ADJUSTING THE	
OPERATION OF CONTROLS .....	7	MAIN BRUSH PATTERN .....	27
PROPEL CONTROL HANDLES .....	7	SIDE BRUSH .....	28
FILTER SHAKER OVERRIDE SWITCH	7	REMOVING THE SIDE BRUSH ...	28
BATTERY CHARGE INDICATOR .....	8	INSTALLING THE SIDE BRUSH ...	28
BATTERY CHARGER PANEL .....	8	ADJUSTING THE SIDE BRUSH ...	28
HOUR METER .....	9	DEBRIS HOPPER & DUST FILTER .....	29
MAIN BRUSH LEVER .....	9	DEBRIS HOPPER .....	29
SIDE BRUSH ARM .....	10	CHECKING AND ADJUSTING	
PARKING BRAKE LEVER .....	10	THE HOPPER FLOOR	
CIRCUIT BREAKERS AND FUSES ...	11	CLEARANCE .....	29
BRUSH INFORMATION .....	11	ADJUSTING THE DUST FILTER	
MACHINE OPERATION .....	12	TO HOPPER SEALING .....	29
PRE-OPERATION CHECKLIST .....	12	THERMO-SENTRY .....	30
SWEEPING .....	12	DUST FILTER .....	30
EMPTYING THE HOPPER .....	13	REMOVING THE DUST FILTER ...	30
REMOVING THE HOPPER .....	14	INSTALLING THE DUST FILTER ..	30
MACHINE TROUBLESHOOTING .....	15	SKIRTS & SEALS .....	31
MAINTENANCE .....	16	HOPPER LIP SKIRT .....	31
MAINTENANCE CHART .....	16	REAR BRUSH SKIRTS .....	31
LUBRICATION .....	18	HOPPER TOP SEAL .....	31
DRIVE CHAINS .....	18	MAIN BRUSH SKIRTS AND SEALS ..	31
DIFFERENTIAL .....	18	PROPEL HANDLE ASSEMBLY .....	32
BRUSH ARM PIVOTS .....	18	ADJUST PROPEL HANDLE	
REAR CASTER .....	18	ASSEMBLY .....	32
SIDE BRUSH GEAR BOX .....	19	TRANSPORTING AND STORING	
SELF ADJUSTING SHEAVE .....	19	THE MACHINE .....	33
BATTERIES .....	20	TRANSPORTING THE MACHINE ...	33
LEAD ACID BATTERIES .....	20	STORING MACHINE .....	33
CHARGING BATTERIES .....	21	SPECIFICATIONS .....	34
ELECTRIC MOTORS .....	23	GENERAL MACHINE	
BELTS & CHAINS .....	23	DIMENSIONS/CAPACITIES .....	34
PROPELLING BELTS .....	23	GENERAL MACHINE PERFORMANCE ..	34
CHECKING AND ADJUSTING THE		POWER TRAIN .....	34
PROPELLING BELT TENSION .	23	TIRES .....	35
SIDE BRUSH BELT .....	24	MACHINE DIMENSIONS .....	35
CHECKING AND ADJUSTING THE		INDEX .....	36
SIDE BRUSH BELT TENSION .	24		
MAIN BRUSH BELTS .....	25		
VACUUM FAN BELT .....	25		
CHECKING AND ADJUSTING THE			
VACUUM FAN BELT TENSION .	25		
WHEEL DRIVE CHAINS .....	26		
STATIC DRAG CHAIN .....	26		

## SAFETY PRECAUTIONS

The following symbols are used throughout this manual as indicated in their description:



**WARNING:** To warn of hazards or unsafe practices that could result in severe personal injury or death.

**FOR SAFETY:** To identify actions that must be followed for safe operation of equipment.

The following information signals potentially dangerous conditions to the operator or equipment. Read this manual carefully. Know when these conditions can exist. Locate all safety devices on the machine. Then, take necessary steps to train machine operating personnel. Report machine damage or faulty operation immediately. Do not use the machine if it is not in proper operating condition.



**WARNING:** Batteries emit hydrogen gas. Explosion or fire can result. Keep sparks and open flame away. Keep covers open when charging.



**WARNING:** Disconnect battery cables and charger plug before servicing machine. Do not charge batteries with damaged power supply cord. Do not modify plug.

If the charger supply cord is damaged or broken, it must be replaced by the manufacturer or its service agent or a similarly qualified person in order to avoid a hazard.



**WARNING:** Heavy hopper. Do not remove without help. Can cause back strain.

This machine is not equipped with explosion proof motors. The electric motors will spark upon start up and during operation which could cause a flash fire or explosion if machine is used in an area where flammable vapors/liquids or combustible dusts are present.

### FOR SAFETY:

1. **Do Not Operate Machine:**
  - Unless Trained And Authorized.
  - Unless Operation Manual Is Read And Understood.
  - In Flammable Or Explosive Areas Unless Designed For Use In Those Areas.
  - Do Not Pick Up Flammable Or Toxic Material, Burning Or Smoking Debris, Or Hazardous Dust
2. **Before Starting Machine:**
  - Make Sure All Safety Devices Are In Place And Operate Properly.
3. **When Using Machine:**
  - Go Slow On Grades And Slippery Surfaces.
  - Use Care When Backing Machine.
  - Do Not Operate On Inclines That Exceed 8.75% (5°) With A Full Hopper, Never Operate On Inclines That Exceed 12.2% (7°)
4. **Before Leaving Or Servicing Machine:**
  - Stop On Level Surface.
  - Set Parking Brake.
  - Turn Off Machine And Remove Key.
5. **When Servicing Machine:**
  - Avoid Moving Parts. Do Not Wear Loose Jackets, Shirts, Or Sleeves When Working On Machine.
  - Use Hoist Or Jack Of Adequate Capacity To Lift Machine.
  - Wear Eye And Ear Protection When Using Pressurized Air Or Water.
  - Disconnect Battery Connections Before Working On Machine.
  - Avoid Contact With Battery Acid.
  - Use TENNANT Supplied Or Equivalent Replacement Parts.
6. **When loading/unloading machine onto/off truck or trailer.**
  - Turn off machine.
  - Use truck or trailer that will support the weight of the machine.
  - Use winch. Do not push the machine onto/off the truck or trailer unless the load height is 380 mm (15 in) or less from the ground.
  - Block machine tires.
  - Tie machine down to truck or trailer.

The following safety decals are mounted on the machine in the locations indicated. If these, or any decal becomes damaged or illegible, install a new decal in its place.

**FOR SAFETY LABEL - LOCATED ON THE CONTROL PANEL.**



**CHARGER CORD LABEL - LOCATED NEAR CHARGER.**

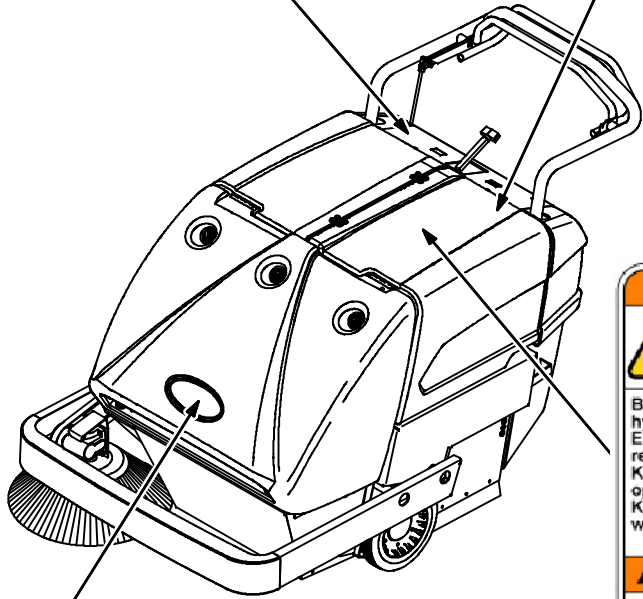
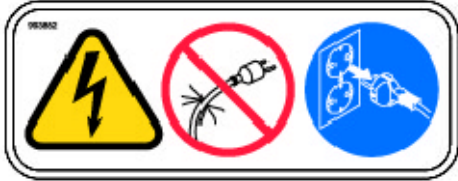

**BACK STRAIN LABEL - LOCATED ON THE TOP OF THE HOPPER.**

**BATTERY CHARGING LABEL - LOCATED ON THE LEFT SIDE PANEL.**

**MACHINE COMPONENTS**

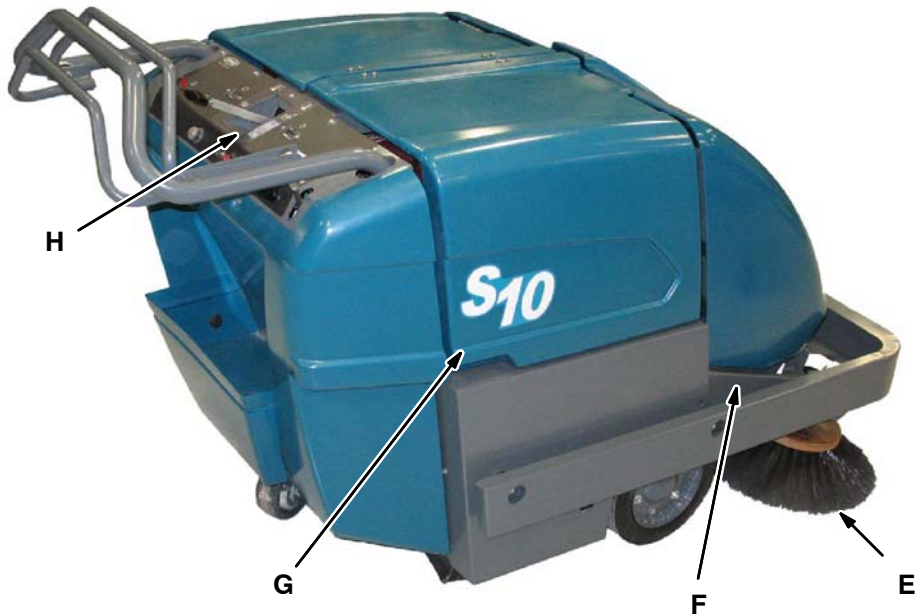

- A. Filter Cover
- B. Left Access Cover
- C. Parking Brake Lever
- D. Hopper
- E. Side Brush
- F. Side Brush Arm
- G. Right Access Cover
- H. Instrument Panel

**SYMBOL DEFINITIONS**

The symbols are used to identify controls and displays on the machine:



WWW Filter Shaker



Main Brush Free-Float



1  
Main Brush Down



2  
Main Brush Up



Main Brush Adjust



15 A  
Circuit Breaker



60 A  
Circuit Breaker



Hour Meter



Battery Charge Indicator



Electric Key Switch



Key Switch Off



Key Switch On

# OPERATION

## CONTROLS AND INSTRUMENTS

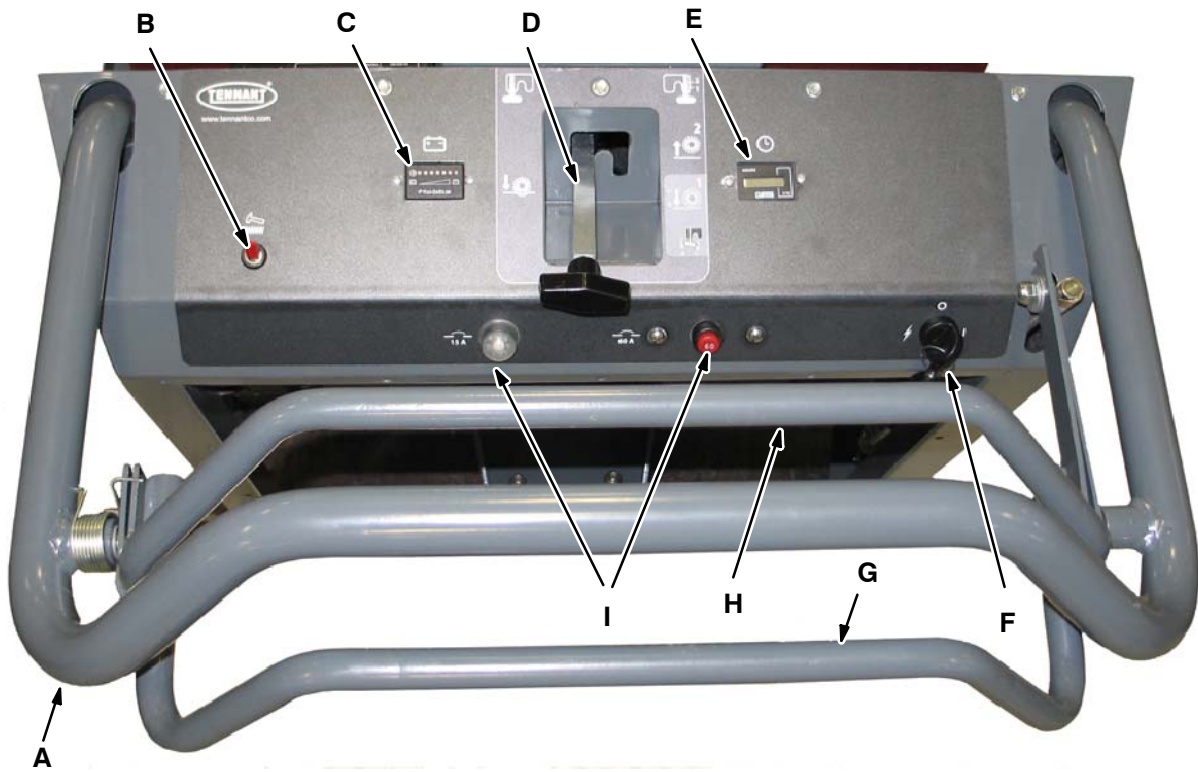

- A. Stationary Handle
- B. Filter Shaker Override Switch
- C. Battery Charge Indicator
- D. Main Brush Lever
- E. Hour Meter
- F. On-Off Key Switch
- G. Forward Propel Handle
- H. Reverse Propel Handle
- I. Circuit Breakers
- J. Charger Panel



---

**OPERATION OF CONTROLS**

---

**PROPEL CONTROL HANDLES**

The propel control handles control the direction of the machine.

To move the machine forward, wrap the fingers around the stationary handle, then press the palms of the hand against the propel handle. To stop the machine, release the handle.

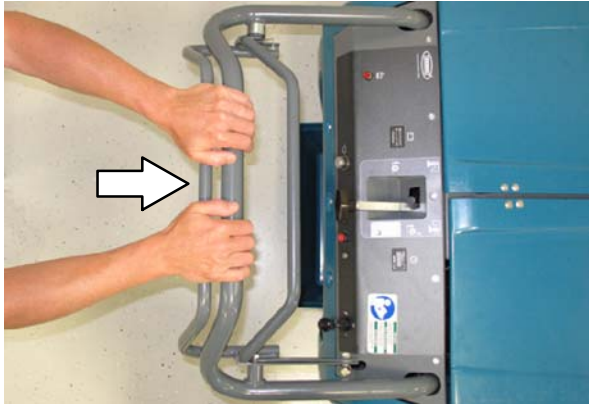

To move the machine backward, squeeze the reverse propel handle. To stop the machine, release the handle.

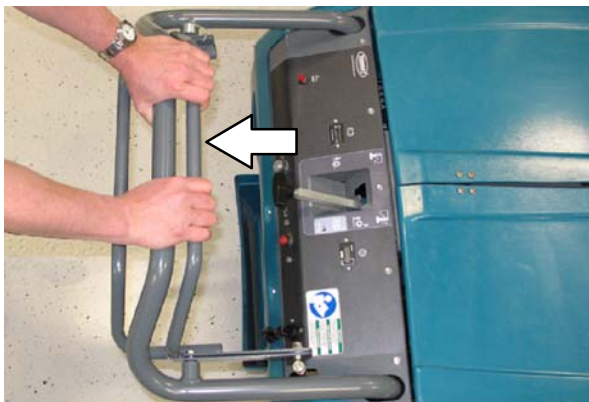
**FILTER SHAKER OVERRIDE SWITCH**

The filter shaker override switch enables the automatic filter shaker. When the switch is in the "on" position, the filter shaker motor will shake the dust from the filter for 20 seconds when the machine is turned off. The switch should be in the "on" position during normal operation.

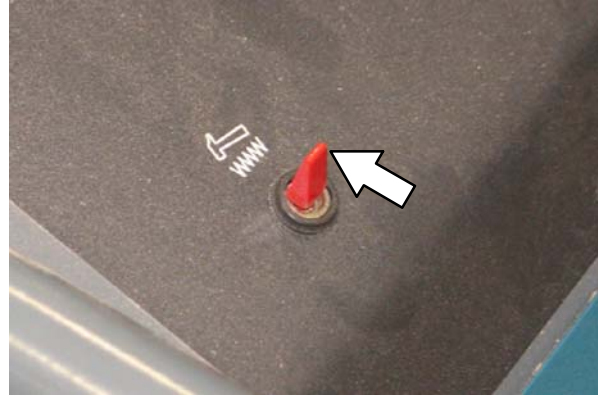

When the switch is in the "off" position, the filter shaker motor will not operate when the machine is turned off. The switch should be in the "off" position when servicing the machine.

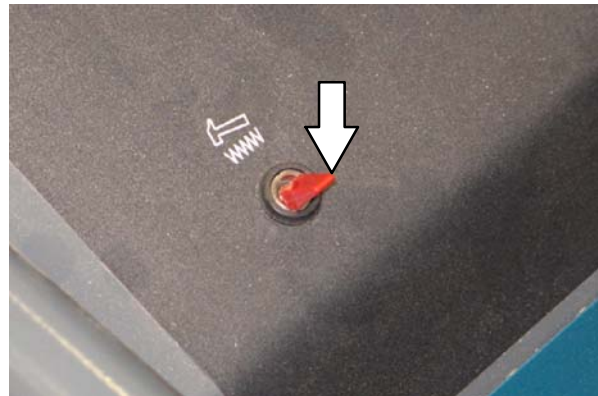

## OPERATION

### BATTERY CHARGE INDICATOR

The *battery discharge indicator* shows the charge level of the batteries.

When the batteries are fully charged, all seven lights are lit.

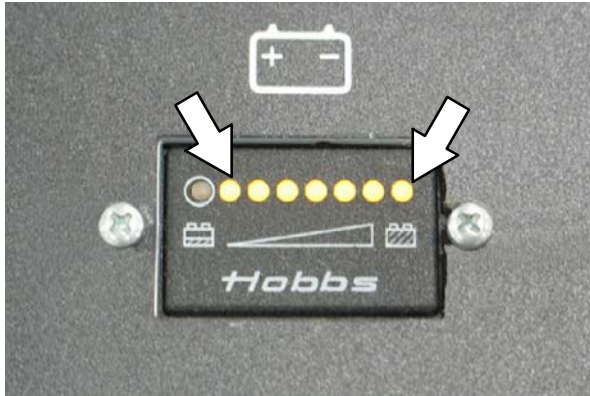

As the batteries discharge, the lights go out until only the left light is blinking. Sweeping functions will continue. Recharge the batteries when only the left light is blinking.

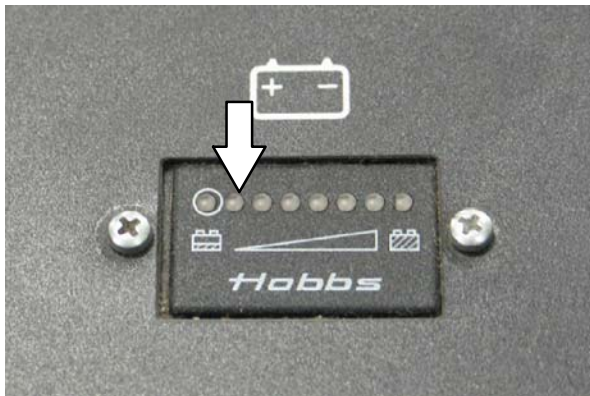

When the red light lights up, the machine will completely shut down.

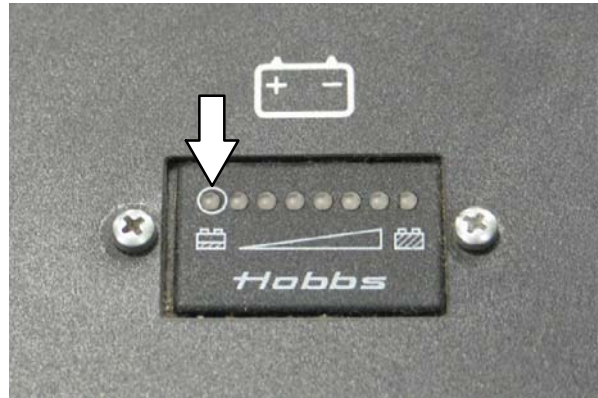

**NOTE:** Do not charge batteries more often than necessary. Excessive charging could reduce the life of the batteries. It is best to charge the batteries only when the left light indicates that the battery needs charging. See **BATTERIES** in the **MAINTENANCE** section.

**NOTE:** The blinking left battery discharge light will not reset from blinking until the batteries are fully charged.

### BATTERY CHARGER PANEL

The battery charger panel shows the status of charging after the charger has been plugged into a wall outlet.

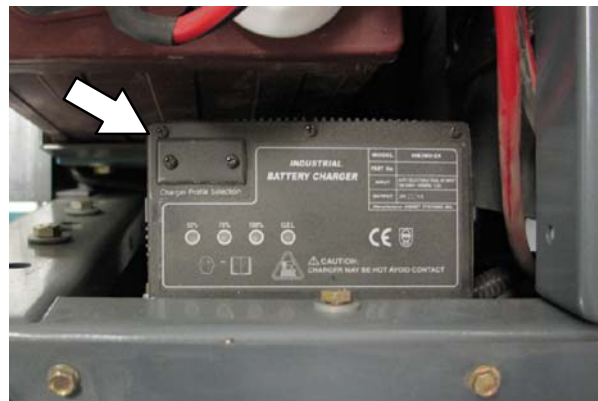

**HOUR METER**

The hour meter records the number of hours the machine has operated. This information is useful in determining when to service the machine.

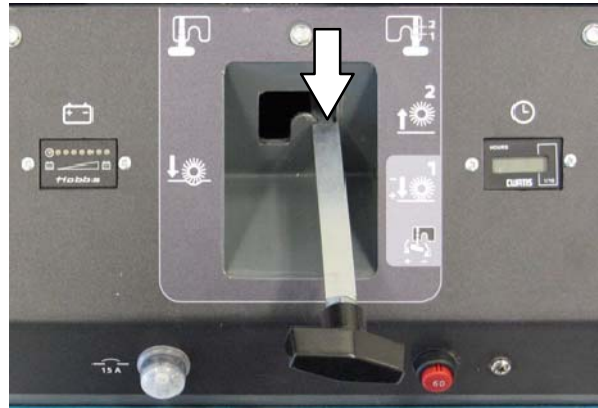

**Main brush down position: (Smooth even floors)**  
Push the lever forward and then pull it back and lock the top notch in the lever in the Main Brush Down position.

**MAIN BRUSH LEVER**

The main brush lever controls the position of the main brush.

**Main brush up position:** Pull the lever up and lock the bottom notch of the lever into the Main Brush Up position.

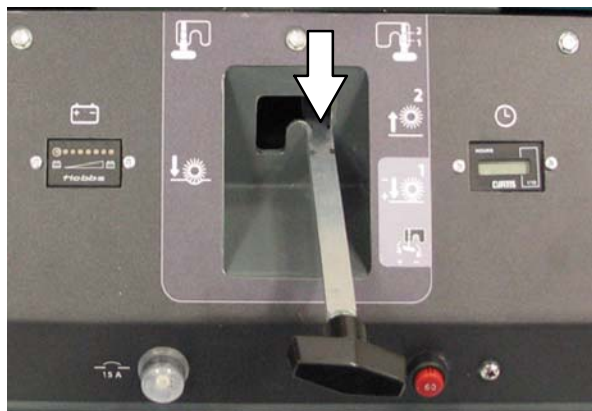

**Main brush free-float position: (Uneven floors)**  
Push the lever forward and then to the left and release it in the Main Brush Free-Float position.

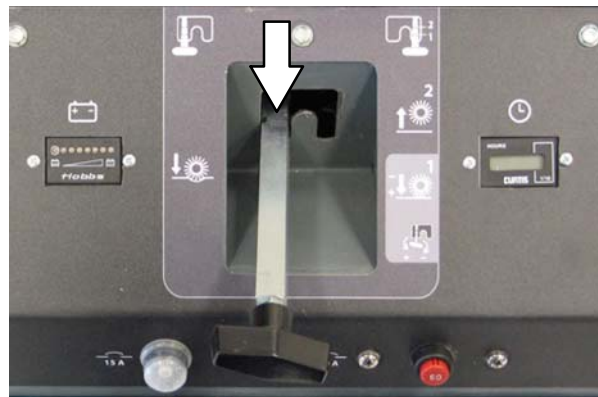

When parking the machine, always raise the brush to prevent the bristles from taking a set.



## OPERATION

### SIDE BRUSH ARM

The side brush arm controls the position of the side brush.

To raise the side brush, pull the lift arm up and push it back into the raised position. To lower the side brush, pull the arm forward and release it into the down position.



When parking the machine, always raise the brush to prevent the brush bristles from taking a set.

### PARKING BRAKE LEVER

To set the parking brake, step on the lever and release it into the long notch on the left.



To release the parking brake, step on the lever and release it into the short notch on the right.

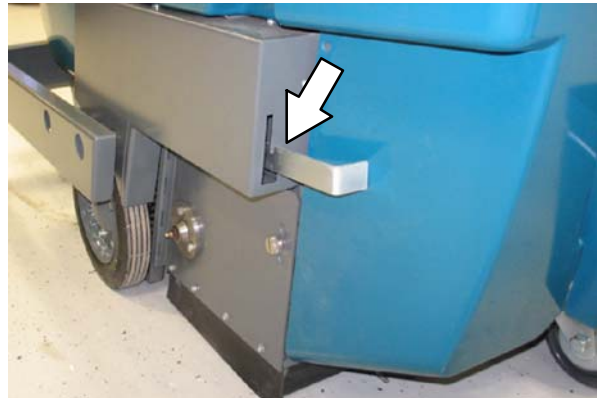

**CIRCUIT BREAKERS AND FUSES**

*Circuit breakers* are resettable electrical circuit protection devices that stop the flow of current in the event of a circuit overload. Once a circuit breaker has tripped, allow breaker to cool and then press the reset button to manually reset the breaker.

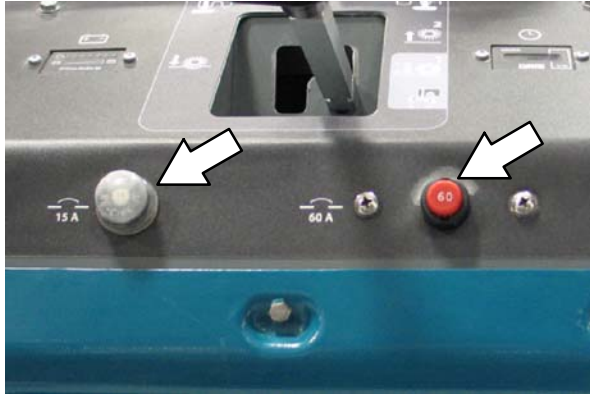

The *fuse* is a one-time protection device designed to stop the flow of current in the event of a circuit overload. The 15 A fuse is located behind the hopper on the main frame.

*NOTE: Always replace the fuse with a fuse of the same type and amperage.*

The following chart shows the various circuit breakers and fuses and the electrical components they protect.

PROTECTIVE DEVICE	RATING	CIRCUIT PROTECTED
CB-1	15 A	Shaker Motor
CB-2	60 A	Main Drive (Propel) Motor
FU-1	15 A	Control Power

**BRUSH INFORMATION**

For best results, use the correct brush type for the cleaning application. Listed below are the brushes and the applications for which each is best suited.

*NOTE: The amount and type of soilage play an important role in determining the type of brushes to use. Contact a Tennant representative for specific recommendations.*

**Nylon 6-Double Row Main Brush -**

Recommended for general sweeping, and has good hopper loading. Nylon has the longest life of the bristle types. Use this brush for sweeping rough or irregular surfaces.

**Polypropylene 6-Double Row Main Brush -**

Superior pick-up of sand, gravel, and paper litter. Polypropylene retains its stiffness when wet and can be used indoors or outdoors with equal performance. Not recommended for high-temperature debris.

**Fiber and Wire 6-Row Main Brush -**

Offers good sweeping action and pickup in heavy dust concentrations. This brush is recommended where soilage is slightly encrusted. The brush is not recommended for heavy buildup or hard packed soilage.

**Natural Fiber 18-Row Main Brush -**

The natural choice for cleaning fine debris on carpet and sweeping very heavy dust and other fine particles on hard surfaces.

# OPERATION

## MACHINE OPERATION

### PRE-OPERATION CHECKLIST

- Check the battery charge level.
- Check the hopper lip skirt for damage and wear.
- Check the hopper seal for damage and wear.
- Check the dust filter for damage.
- Check the condition of the main brush. Remove any string, banding, plastic wrap, or other debris wrapped around the brush.
- Check the main brush and rear brush skirts for damage, wear, and clearance.
- Side Brush Option: Check the condition of the side brush. Remove any string, banding, plastic wrap, or other debris wrapped around the brush.
- Check the service records to determine maintenance requirements.

### OPERATION ON GRADES

Drive the machine slowly on grades. The maximum rated climb angle is 7° or 12.2%.

**FOR SAFETY: When Using Machine; Go Slow On Grades And Slippery Surfaces.**

## SWEEPING

Plan the sweeping in advance. Try to arrange long runs with minimum stopping and starting. Overlap brush paths. Sweep as straight a path as possible. Avoid bumping into posts or scraping the sides of the sweeper. Sweep debris from very narrow aisles into main aisles ahead of time. Do an entire floor or section at one time.

Pick up oversize debris before sweeping. Pick up pieces of wire, twine, or string, which could become entangled in brush or brush plugs.

1. Turn the on-off switch key to the on position.



2. Release the machine parking brake, if equipped.
3. Move the main brush lever into the (Main Brush Down) or (Main Brush Free-Float) position.
4. Move the side brush arm into the down position.
5. Sweep as required.
6. Raise the main brush and side brush.

- Turn the on-off switch key to the left.  
Remove the key from the on-off switch.



**FOR SAFETY: Before leaving or servicing machine; stop on level surface, set parking brake, and turn off machine.**

### EMPTYING THE HOPPER

- Pull the main brush lever into the (Main Brush Up) position.
- Pull the side brush arm into the raised position.
- Slowly drive the machine up to the dump site. Turn off the machine. The filter will operate for approximately 20 seconds.

*NOTE: The filter shaker override switch must be in the "on" position to automatically shake the dust filter when the machine is turned off.*

**FOR SAFETY: Before leaving or servicing machine; stop on level surface, set parking brake, and turn off machine.**

- Lift the filter cover.

- Swing the dump lever (B) under the hook (C); Lift the dump lever to dump the hopper (A).

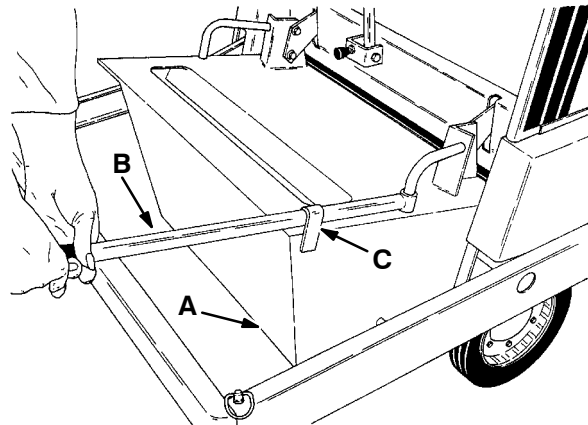

**A. Hopper  
B. Dump Lever  
C. Lever Hook**

03142

- Engage the lever hook (not shown) to keep the hopper in the "dump" position.
- Slowly back the machine away from the dump site or remove the hopper from the machine to empty the contents from the hopper.

*NOTE: See REMOVING THE HOPPER in the following section if it is necessary to remove the hopper from the machine to empty the hopper.*

- Release the lever hook (not shown), lower the hopper, and return the dump lever to its storage location.
- Lower the filter cover.

## OPERATION

### REMOVING THE HOPPER

1. Pull the main brush lever into the (Main Brush Up) position.
2. Pull the side brush arm into the raised position.
3. Turn off the machine. The filter will operate for approximately 20 seconds.

*NOTE: The filter shaker override switch must be in the "on" position to automatically shake the dust filter when the machine is turned off.*

**FOR SAFETY: Before leaving or servicing machine; stop on level surface, set parking brake, and turn off machine.**

4. Lift the filter cover.
5. Seek assistance to remove the hopper from the machine. Lift the hopper out of the machine.



**⚠ WARNING: Heavy hopper. Do not remove without help. Can cause back strain.**

6. Reinstall the hopper into the machine. Make sure the hooks on hopper are completely installed onto the machine.

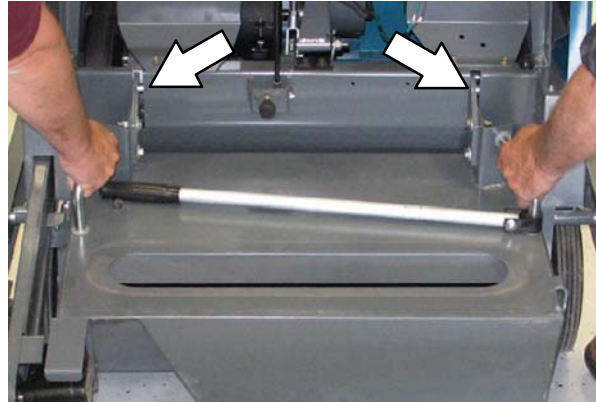

7. Close the filter cover.



---

**MACHINE TROUBLESHOOTING**

---

Problem	Cause	Remedy
Excessive dusting	Dust skirts and seals worn, damaged, not adjusted properly	Replace or adjust skirts or seals
	Dust filter clogged	Shake and/or clean or replace filter
	Vacuum hose damaged	Replace vacuum hose
	Vacuum fan belt slipping or broken	Adjust or replace belt
Poor sweeping performance	Brush bristles worn	Replace brushes
	Brushes not adjusted properly	Adjust brushes
	Brushes not installed properly	Reinstall brushes
	Debris caught in brush drive mechanism	Free mechanism of debris
	Hopper not adjusted properly	Adjust hopper floor clearance
	Hopper full	Empty hopper
	Hopper floor skirts worn, damaged	Replace skirts
	Brush belt slipping, or broken	Replace belt
Battery charger not operating	Charger not plugged into electrical receptacle	Plug charger into electrical receptacle
	Charger cord not completely plugged into bottom of charger	Replug charger cord into charger
	Charger cord is damaged	Replace charger cord

**MAINTENANCE**

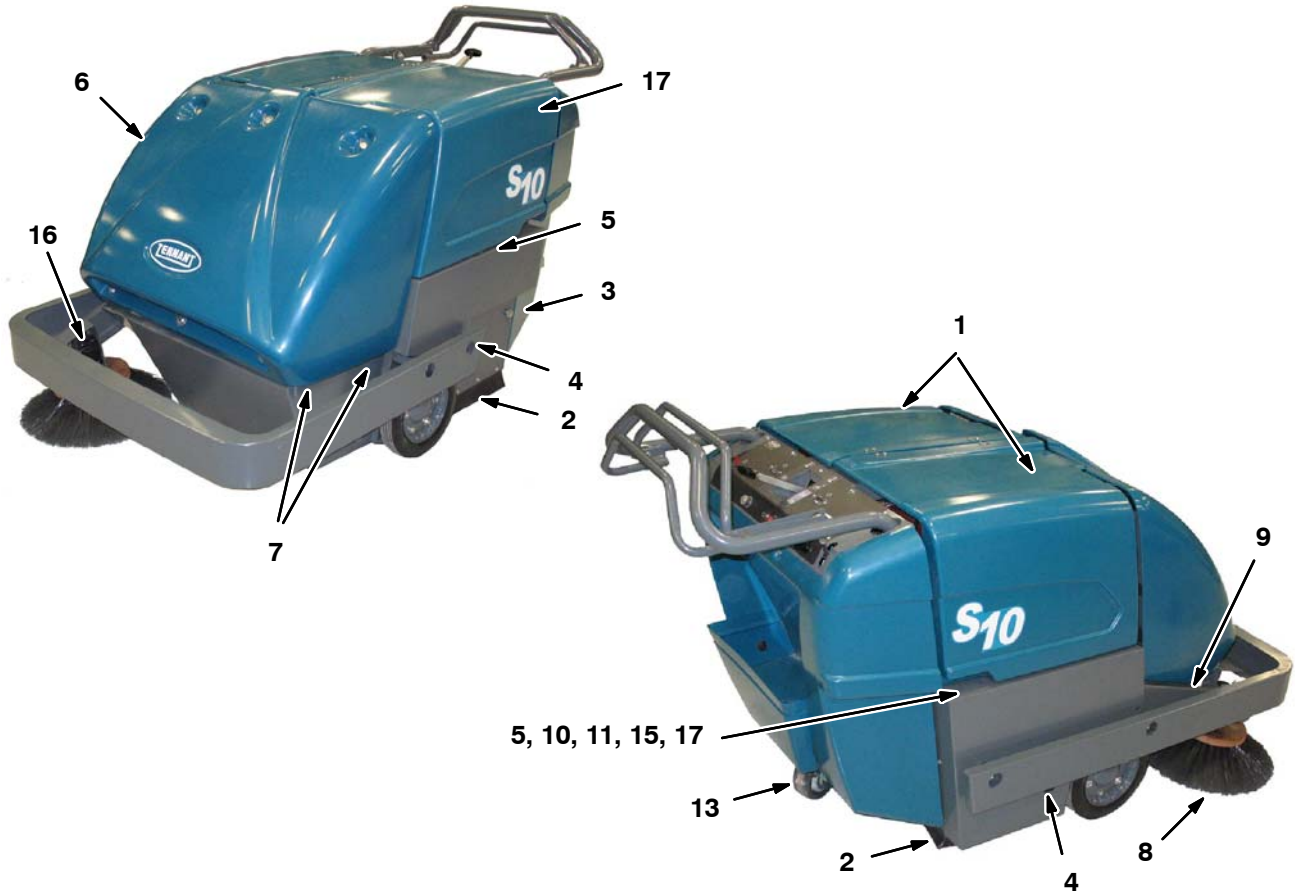

**MAINTENANCE CHART**

Interval	Key	Description	Procedure	Lubricant/ Fluid	No. of Service Points
Daily	2	Brush skirts	Check for damage, wear, and floor clearance	-	5
	3	Main brush	Check for damage, wear, debris	-	1
	8	Side brush	Check for damage, wear, debris	-	1
	7	Hopper	Check seals for damage and wear	-	3
25 Hours	1	Battery cells	Check electrolyte level	DW	2
	3	Main brush	Check floor pattern <b>(after initial 25 hours only)</b>	-	1
	5	Drive chains	Check and adjust tension <b>(after initial 25 hours only)</b>	-	2

Interval	Key	Description	Procedure	Lubricant/ Fluid	No. of Service Points
50 Hours	14	Vacuum fan belt	Check tension and wear	-	1
	10	Propelling belts	Check tension and wear	-	2
	10	Main brush belts	Check tension and wear	-	2
	9	Side brush belts	Check tension and wear	-	2
	8	Side brush	Check pressure	-	1
	3	Main brush	Check floor pattern Rotate end-for-end	-	1
	4	Brush arm pivots	Lubricate	SPL	2
	13	Rear caster	Lubricate	SPL	1
	7	Hopper	Check floor clearance	-	1
	17	Battery charger cable	Check for wear and damage	-	1
100 Hours	5	Drive chains	Check and adjust tension	-	2
			Lubricate	SO	2
	6	Dust filter	Clean or replace	-	1
	11	Self adjusting sheave	Lubricate	SPL	1
	1	Batteries	Clean top surface and terminals	-	2
	17	Differential	Lubricate	SPL	1
400 Hours	15	Propelling motor	Blow out dust and inspect	-	1
	16	Side brush gear box	Check lubricant level	GL	1

**LUBRICANT/FLUID**

DW - Distilled water

SPL - Special lubricant, Lubriplate EMB grease, TENNANT Part No. 01433-1

SO - Spray lubricant

GL - SAE 90 Weight gear lubricant

*NOTE: More frequent intervals may be required in extremely dusty conditions.*

# MAINTENANCE

## LUBRICATION

### DRIVE CHAINS

Check the tension and lubricate the drive chains (A) with a penetrating-type spray lubricant after every 100 hours of operation.

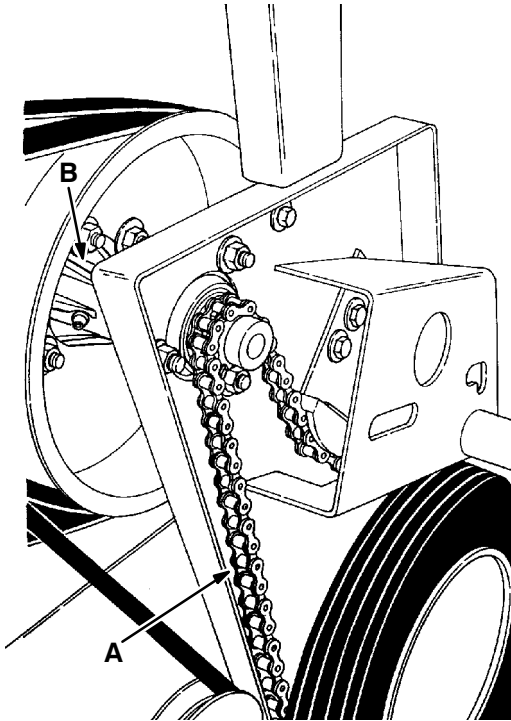

A. Drive Chain  
B. Differential

03139

### DIFFERENTIAL

Lubricate the differential (B) every 100 hours of operation. The differential grease fitting is located on the drive shaft inside the drive sheave.

### BRUSH ARM PIVOTS

Lubricate the brush arm pivots after every 50 hours of operation.

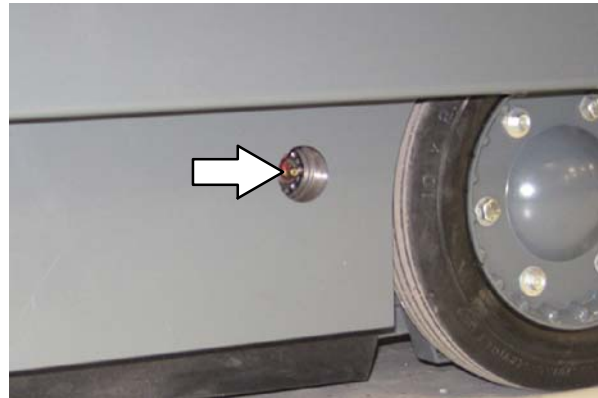
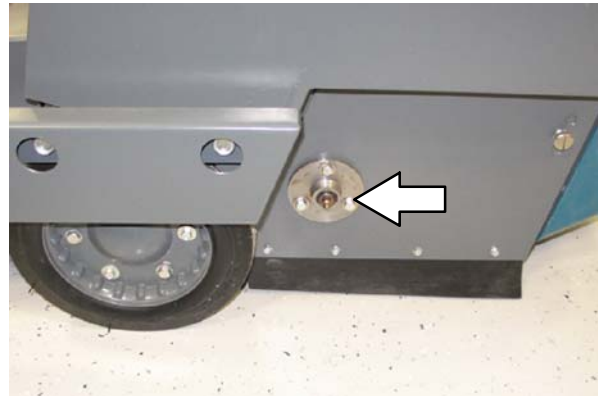

### REAR CASTER

Lubricate the rear caster after every 50 hours of operation.

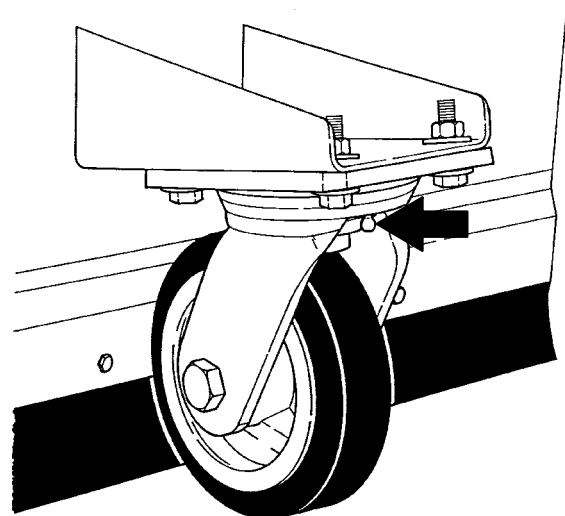

**SIDE BRUSH GEAR BOX**

Check the side brush gear box fluid level after every 400 hours of operation. Remove the breather by unscrewing it with a wrench. Fill the gear box to within 0.25 in (6 mm) of the top.

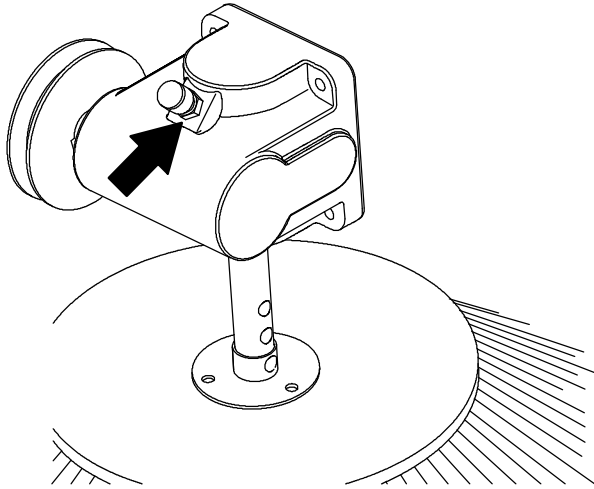
**SELF ADJUSTING SHEAVE**

Lubricate the sheave shaft after every 100 hours of operation. Avoid getting oil on the belt or sheave surfaces.

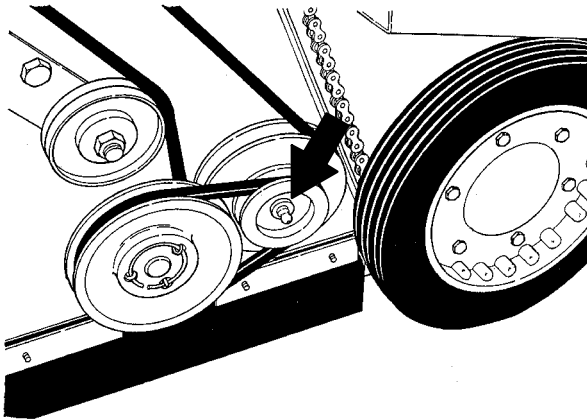

03141

## BATTERIES

The batteries are designed to hold their power for long periods of time. The lifetime of the batteries is limited to number of charges the batteries receive. To get the most life from the batteries, recharge them immediately when the battery discharge indicator begins to blink.



**FOR SAFETY: When servicing machine, wear protective gloves when handling batteries or battery cables. Avoid contact with battery acid.**

After every 100 hours of use check for loose battery connections and clean the surface of the batteries, including terminals and cable clamps, using a strong solution of baking soda and water. Brush the solution sparingly over the battery tops. Do not allow any baking soda solution to enter the batteries. Use a wire brush to clean the terminal posts and the cable connectors. Wipe off all cleaning solution residue. After cleaning, apply a coating of clear battery post protectant to the terminals and the cable connectors. Keep the tops of the batteries clean and dry.

Objects made of metal can potentially short circuit the batteries. Keep all metallic objects off the batteries. Replace any worn or damaged wires. Replace any defective batteries. To dispose of batteries, contact a battery dealer or your Tennant Service representative.

## LEAD ACID BATTERIES

Check the electrolyte level in each battery cell before and after charging, and after every 25 hours of operation. Never add acid to the batteries. Add distilled water *only*. Always keep the battery caps on, except when adding water or taking hydrometer readings.

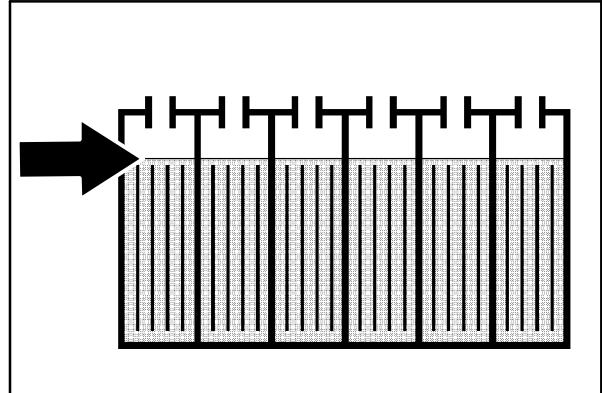

Using a hydrometer, measure the specific gravity to determine the charge level and condition of the batteries. If one or more of the battery cells test lower than the other battery cells (0.050 or more), the cell is damaged, shorted, or is near failure. Completely recharge the batteries and then retest.

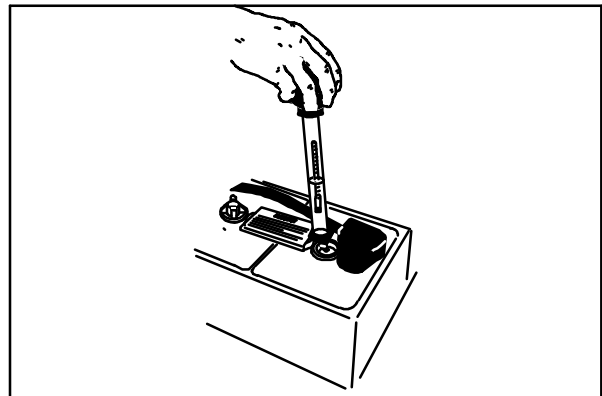

0438C

*NOTE: Do not take readings immediately after adding distilled water. If the water and acid are not thoroughly mixed, the readings may not be accurate. Check the hydrometer readings against the following chart to determine the remaining battery charge level:*

<b>SPECIFIC GRAVITY at 27° C (80° F)</b>	<b>BATTERY CHARGE</b>
1.265	100% Charged
1.225	75% Charged
1.190	50% Charged
1.155	25% Charged
1.120	Discharged

*NOTE: If the readings are taken when the battery electrolyte is any temperature other than 27° C (80° F), the reading must be temperature corrected. Add or subtract to the specific gravity reading 0.004, 4 points, for each 6° C (10° F) above or below 27° C (80° F).*

**CHARGING BATTERIES**

The following charging instructions are intended for battery chargers supplied with the machine.

After every 50 hours check the battery charger cord for damage.

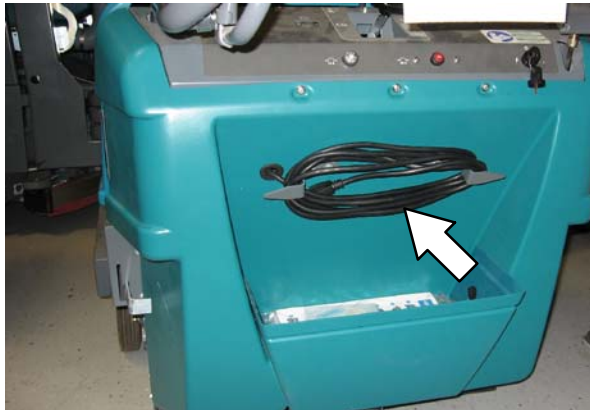

To prolong the life of the batteries only recharge the batteries if the machine was used for a total of 30 minutes or more. Do not leave batteries discharged for lengthy periods.

**⚠ WARNING: Fire Or Explosion Hazard.** Batteries emit hydrogen gas. Keep sparks and open flame away. Keep battery compartment open when charging.

**FOR SAFETY: When servicing batteries, wear protective gloves and eye protection when handling batteries and battery cables. Avoid contact with battery acid.**

Make sure the charger profile is properly set for the battery type before charging. Failure to properly set profile will result in battery damage. To determine the battery type, see battery label. Contact the battery supplier if not specified.

To verify the charger profile setting, connect the charger cord into an electrical receptacle. If the LED labeled “GEL” is on, the charger is set for Gel (sealed) batteries. If the LED is off, the charger is set for Wet/lead acid (flooded) batteries.

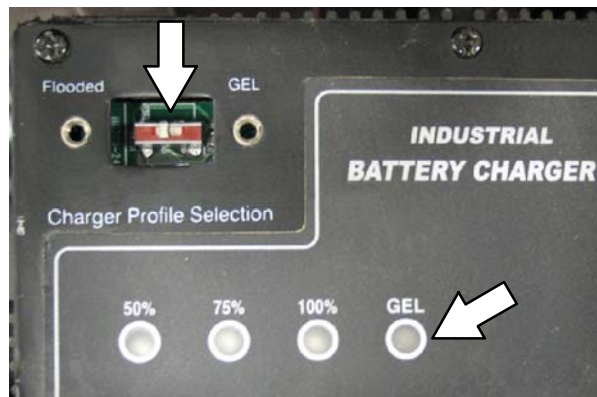

To change the charger profile, unplug the charger, remove the “Charger Profile Selection” panel, and position the switch towards the proper setting, “GEL” or “Flooded” .

1. Transport the machine to a well-ventilated area for charging.

**FOR SAFETY: Before leaving or servicing machine; stop on level surface, set parking brake, and turn off machine.**

2. If charging wet (lead acid) batteries check the fluid level before charging (See BATTERY MAINTENANCE).
3. Remove the battery compartment covers for ventilation when charging.



## MAINTENANCE

- Connect the charger cord into a properly grounded electrical receptacle. The charger will start automatically within a few seconds. The LEDs will display the charging state as described in the following table.



**NOTE:** The machine will not operate once the battery charger is connected.

- Once the batteries are fully charged, the charger will stop supplying power, but will continue to monitor the battery voltage. The charger will restart if the batteries self-discharge.

**NOTE:** The charger may take up to 30 seconds to turn off once the charger cord is disconnected. During this time, the machine will not power up. The charger cord must also be disconnected for 30 seconds before the charger can be restarted.

- Unplug the charger cord.

**NOTE:** To avoid damaging the charger cord, do not pull on the cord to unplug the charger from the electrical receptacle. Use the plug to unplug the cord from the electrical receptacle.

- Reinstall the battery compartment covers.

CHARGING STATE LED DISPLAY			
Charging State	50% LED	75% LED	100% LED
0-50% charged	Blinking	Off	Off
50-75% charged	On	Blinking	Off
75-100% charged	On	On	Blinking
100% charged	On	On	On
Abnormal Cycle*	Off	Off	Blinking
Fault detected *	Blinking	Blinking	Blinking

\* See the On-board Battery Charger Fault Codes table. When a fault occurs, the charger will also sound an alarm.

LED FAULT CODE	FAULT	SOLUTION
3 LEDs blink once repeatedly	Loose charger cable connection.	Check charger cable connection.
	Loose or damaged battery cable.	Check battery cable connections.
	Defective Battery.	Replace battery.
3 LEDs blink twice repeatedly	Input voltage is out of range.	Try using a different wall outlet.
3 LEDs blink three times repeatedly	Safety thermostat exceeded maximum internal temperature.	Open battery compartment to promote air circulation or move machine to a cooler climate.
3 LEDs blink four times repeatedly	Output current exceeds a limit.	Disconnect charger cord, wait 30 seconds, then plug back in. If fault continues replace charger or contact TARRANT Service.
100% LED blinks while the 50% and 75% LEDs are off.	Abnormal cycle. Safety timer exceeded the 18 hour charging time.	Battery maintenance required or replace battery.



**ELECTRIC MOTORS**

The electric propelling motor is serviceable. The propelling motor is located underneath the battery compartment.

Blow out the dust and inspect the motor brushes in the motor after every 400 hours of operation.

If the brushes have been worn to less than 10 mm (0.38 in) in length, replace them.

If the commutator is worn or rough, the motor armature should be removed and serviced, or replaced.

**BELTS AND CHAINS**

**PROPELLING BELTS**

Check the propelling belts for wear and tension after every 50 hours of operation.

**CHECKING AND ADJUSTING THE PROPELLING BELT TENSION**

**FOR SAFETY: Before leaving or servicing machine; stop on level surface, set parking brake, and turn off machine.**

1. Remove the access cover, bumper, and cover.
2. Observe the position of the clutch plate bolt (C) with no pressure on the clutch handle. It should be approximately in the center of the slot (D).
3. Press the clutch handle to tighten the forward propelling belt (G). The clutch handle should be 7 to 13 mm (0.25 to 0.50 in) from the stationary handle. Observe the position of the clutch plate bolt (C). It should not touch the end of the slot (D). If the handle and bolt are in the proper position, proceed to step 7; if not, continue with step 4 to readjust forward belt tension.

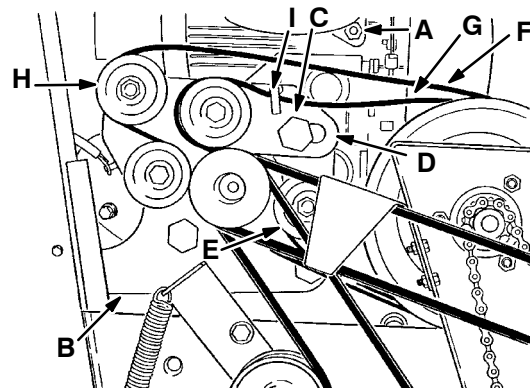

03151

- A. Motor**
- B. Clutch Plate**
- C. Clutch Plate Bolt**
- D. Bolt Slot**
- E. Forward Belt Idler Sheave**
- F. Reverse Propelling Belt**
- G. Forward Propelling Belt**
- H. Reverse Belt Idler Sheave**
- I. Belt Guide**

4. Loosen the forward idler sheave bolt (E) and slide the idler sheave down to tighten the belt (G) (this also increases distance between clutch handle and stationary handle); slide the sheave up to loosen the belt (this also reduces distance between clutch handle and stationary handle).
5. Tighten the idler sheave bolt.
6. Recheck handle and bolt positions. Repeat as necessary to adjust belt tension.

*NOTE: After adjusting the forward belt, it may contact the belt guide when engaged causing a whining noise. To stop the noise, bend the guide up out of the belt's way.*

7. Pull the clutch handle to tighten the reverse propelling belt. Observe the position of the clutch plate bolt (C). It should not touch the end of the slot (D). If the bolt is in the proper position, proceed to step 11; if not, continue with step 8 to readjust reverse belt tension.

*NOTE: If the reverse belt is too tight, it will require excessive clutch handle pressure to propel machine in the forward direction. It may also cause the machine to creep backward when the handle is released. If the reverse belt is too loose, the machine will not propel backward.*

8. Loosen the reverse idler sheave bolt (H) and slide the idler sheave to the rear to tighten the belt (F); slide the sheave forward to loosen the belt.
9. Tighten the reverse idler sheave bolt (H).
10. Pull the clutch handle to recheck the position of the clutch plate bolt (C). Repeat as necessary to adjust belt tension.
11. Reinstall the access cover, and right side cover, and bumper.

### SIDE BRUSH BELT

Check the belt for wear and tension after every 50 hours of operation.

#### CHECKING AND ADJUSTING THE SIDE BRUSH BELT TENSION

**FOR SAFETY: Before leaving or servicing machine; stop on level surface, set parking brake, and turn off machine.**

1. Lift the filter cover.
2. Remove the debris hopper.
3. Remove the access cover, and right side bumper and cover.
4. Place the side brush arm in the down position.
5. Check the belt (A) tension at a point 230 mm (9 in) from the motor shaft. The belt should deflect 20 mm (0.75 in) from a force of 3 kg (6 lb).

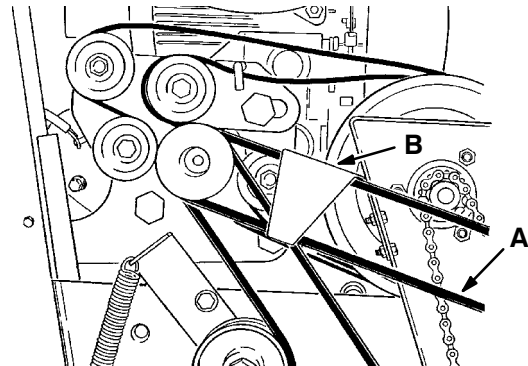

03151

**A. Side Brush Belt  
B. Belt Guide**

6. To adjust belt tension, loosen the button head screw through the side cover (not shown).

- Pull the side brush arm (A) out to tighten the belt.

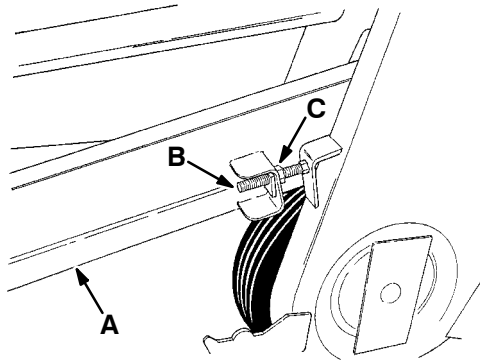

03153

- A. Side Brush Arm**
- B. Stop Bolt**
- C. Lock Nut**

- Tighten the button head screw when the correct tension is reached.
- Adjust the stop bolt (B) so it clears the stop by 5 mm (0.06 in).
- Replace the debris hopper.
- Lower the filter cover.

**MAIN BRUSH BELTS**

Check the main brush belts for wear after every 50 hours of operation.

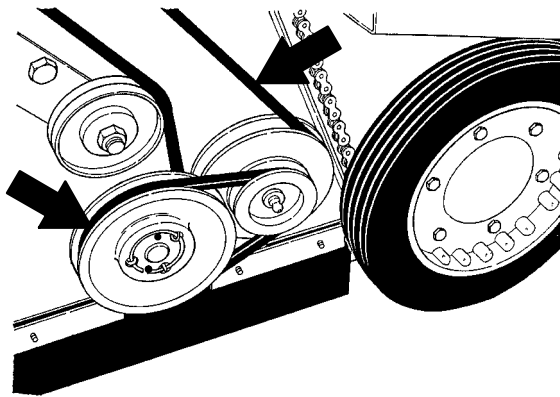

03141

**VACUUM FAN BELT**

Check the vacuum fan belt for wear and tension after every 50 hours of operation.

**CHECKING AND ADJUSTING THE VACUUM FAN BELT TENSION**

**FOR SAFETY: Before leaving or servicing machine; stop on level surface, set parking brake, and turn off machine.**

- Remove the rear panel.
- Check belt deflection by applying a force of 3 kg (6 lb) to the midpoint of the belt span. The belt should deflect 5 mm (0.06 in).
- To adjust belt tension, loosen the belt adjusting stud nut (B). Pull the vacuum fan assembly (A) up to tighten the belt and tighten the stud nut.

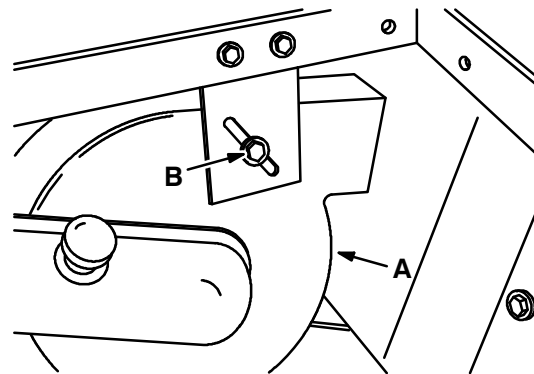

06320

- A. Vacuum Fan**
- B. Stud Nut**

- Tighten all nuts and recheck belt tension.
- Replace the rear panel.

## MAINTENANCE

### WHEEL DRIVE CHAINS

Check the chains for wear or damage and tension after the first 50 hours of operation and then after every 100 hours of operation. The wheel drive chains should have 10 mm (0.40 in) slack measured midway between the sprockets.

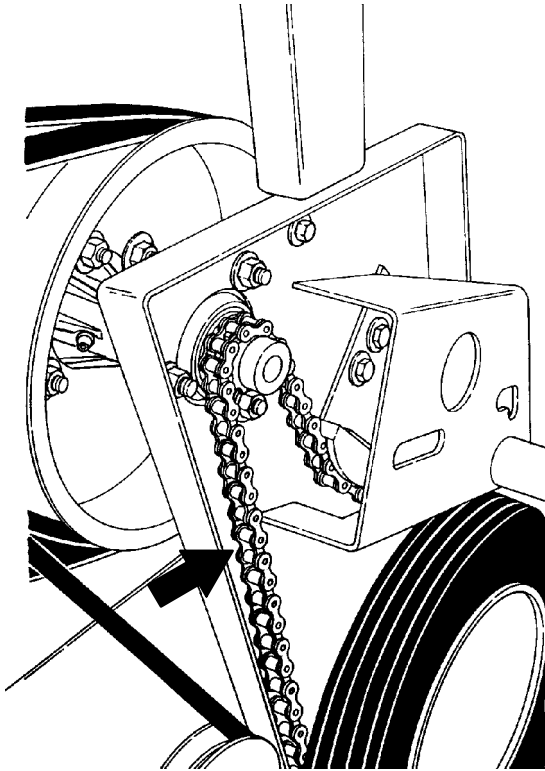

03139

### STATIC DRAG CHAIN

A static drag chain prevents the buildup of static electricity in the machine. Check the chain for wear periodically. Make sure the chain touches the floor at all times.



## BRUSHES

### MAIN BRUSH

Inspect the main brush daily for wear or damage. Remove any string or wire tangled on the main brush, the main brush drive hub, or the main brush idler hub.

Rotate the main brush end-for-end after every 50 hours of operation to obtain maximum brush life. The main brush should be replaced when the remaining bristle measures 15 mm (0.5 in).

The main brush pattern should be checked after every 50 hours of operation. The main brush pattern should be 40 mm (1.5 in) wide.

### REMOVING THE MAIN BRUSH

**FOR SAFETY: Before leaving or servicing machine; stop on level surface, set parking brake, and turn off machine.**

1. Place the main brush lift handle in the (Main Brush Free-Float) position.
2. Open the main brush access door (D).
3. Pull the brush out of the brush compartment.

### INSTALLING THE MAIN BRUSH

*NOTE: The hopper can be removed to aid installing the main brush into the machine. See REMOVING THE HOPPER in the OPERATION section for proper procedure for removing the hopper.*

1. Slide the brush into the brush compartment.
2. Rotate the brush until the slots on the ends of the brush engage the keys on the main brush drive hub (not shown).

*NOTE: Do not force the main brush onto the drive hub. When the main brush slots and drive hub keys are properly aligned, the main brush will easily engage the drive hub.*

- Close and secure the main brush access door (D). **Make sure the lift arm (B) engages the idler lift arm pins (A).**

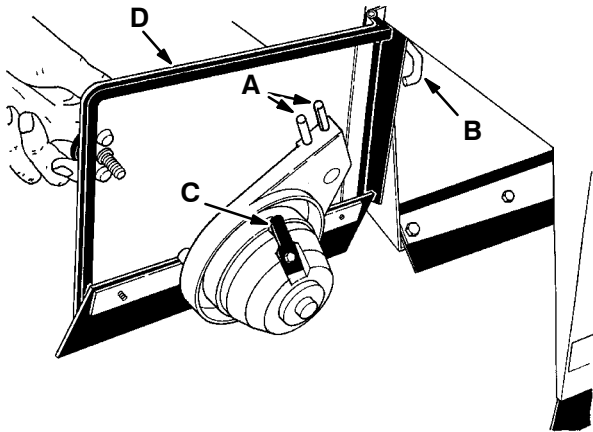

02347

- A. Lift Arm Pins
- B. Lift Arm
- C. Idler Key
- D. Access Door

- Check and adjust main brush pattern as described in *CHECKING AND ADJUSTING THE MAIN BRUSH PATTERN*.

## CHECKING AND ADJUSTING THE MAIN BRUSH PATTERN

- Apply chalk or some material that will not blow away easily, to a smooth, level surface.
- Start the motor.
- With side brush and main brush raised, position main brush over the chalked area.
- While holding the machine in place, move the main brush lift handle in the (Main Brush Down) position. Let the brush remain on the floor for 15 to 20 seconds.
- Place the main brush lift handle in the (Main Brush Up) position.

- Move the machine from the main brush polish mark.
- Stop the motor.
- Observe the width of the polish mark. The proper polish width is 40 mm (1.5 in).

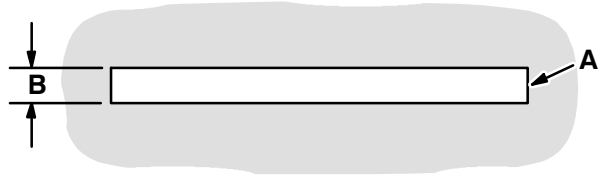

00582

- A. Main Brush Pattern
- B. Polish Width

- Adjust the main brush width as necessary.

To reduce the polish width, turn the main brush lift handle to the right.

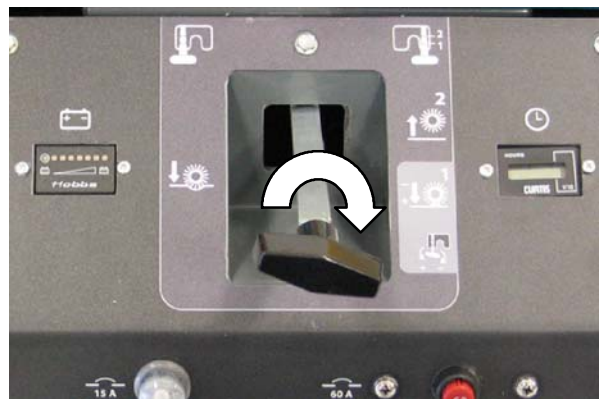

To widen the polish width, turn the main brush lift handle to the left.

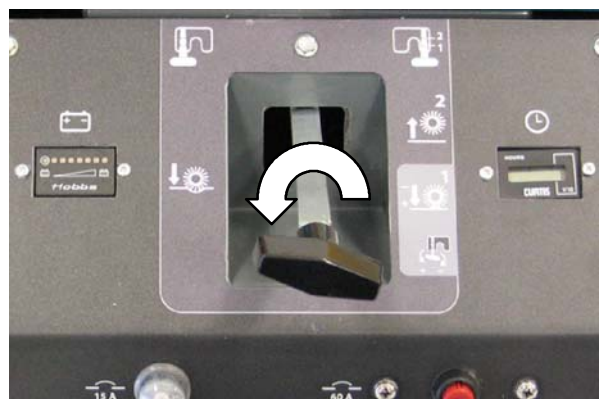

If any adjustments are made, recheck the main brush pattern before operating the machine.

## SIDE BRUSH

The side brush should be inspected daily for wear or damage. Remove any string or wire tangled from the side brush, side brush drive hub, or shaft. The side brush should be replaced when the remaining bristle length measures 25 mm (1 in) in length.

The side brush should be checked after every 50 hours of operation. The side brush is properly adjusted when, with the side brush arm in the raised position, there is approximately 25 mm (1 in) between the floor and the side brush bristles.

## REMOVING THE SIDE BRUSH

**FOR SAFETY: Before leaving or servicing machine; stop on level surface, set parking brake, and turn off machine.**

1. Pull the side brush arm up into the raised position.
2. Remove the side brush mounting hardware (B).

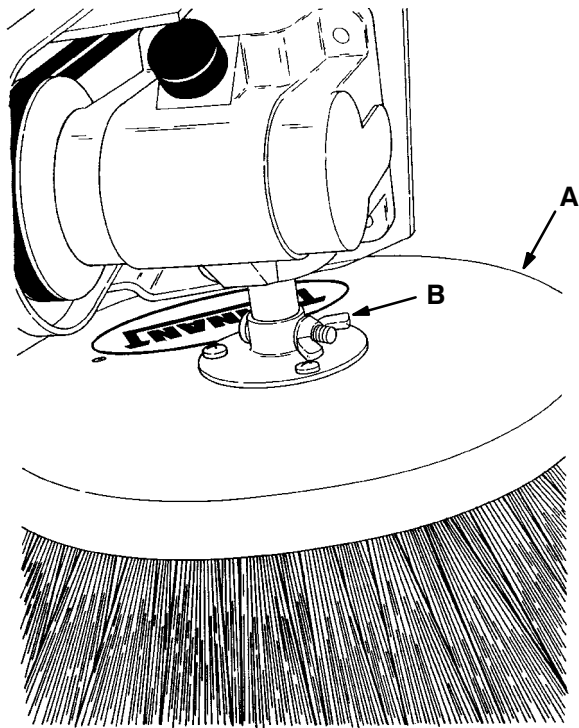

**A. Side Brush**  
**B. Mounting Hardware**

3. Slide the side brush (A) off the drive shaft.

## INSTALLING THE SIDE BRUSH

1. Slide the side brush (A) onto the drive shaft.
2. Secure the side brush (A) with the mounting hardware (B).
3. Check the side brush adjustment as described in *ADJUSTING THE SIDE BRUSH*.

## ADJUSTING THE SIDE BRUSH

**FOR SAFETY: Before leaving or servicing machine; stop on level surface, set parking brake, and turn off machine.**

1. Pull the side brush arm up into the raised position.
2. Remove the side brush mounting hardware.
3. Position the side brush on the shaft until there is approximately 25 mm (1 in) between the floor and the brush bristles.



4. Align the side brush with the drive shaft holes.
5. Secure the side brush to the drive shaft with the mounting hardware.

*NOTE: It may be necessary to readjust the side brush drive belt tension after adjusting the side brush height.*

**DEBRIS HOPPER AND DUST FILTER**

**DEBRIS HOPPER**

The debris hopper should be emptied after every work shift, or when the hopper is full. The debris hopper floor clearance should be checked after every 50 hours of operation. The dust filter to hopper seal can also be adjusted to prevent dusting when shaking the dust filter.

**CHECKING AND ADJUSTING THE HOPPER FLOOR CLEARANCE**

**FOR SAFETY: Before leaving or servicing machine; stop on level surface, set parking brake, and turn off machine.**

1. Empty the debris hopper and replace it on the machine.
2. The bottom rear metal edge of the hopper should clear the floor by 15 mm (0.5 in). Also, be sure the hopper is level side to side.
3. To adjust the hopper (A), loosen the hanger bracket bolts (B), reposition the hanger bracket, and retighten the hanger bracket bolts. Be sure the hopper brackets do not rub against the pivot pins preventing the hopper from floating.

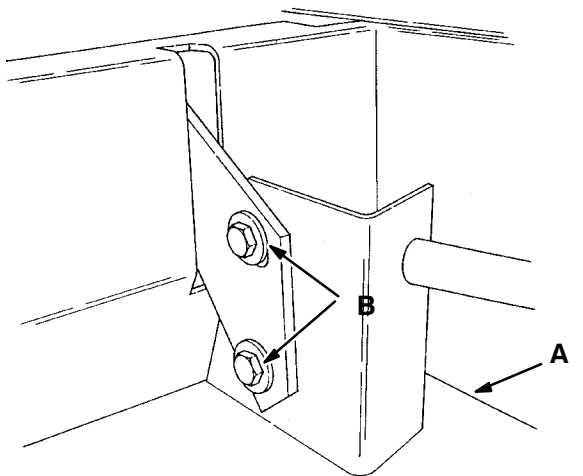

**A. Hopper  
B. Hanger Bracket Bolts**

03159

**ADJUSTING THE DUST FILTER TO HOPPER SEALING**

**FOR SAFETY: Before leaving or servicing machine; stop on level surface, set parking brake, and turn off machine.**

1. Lift the filter assembly.
2. Make sure stop bolt (A) is touching the filter assembly. If it is, continue with step 3. If it is not, loosen bolts and adjust the round vacuum fan seal bracket (C) back to allow the assembly to touch the stop bolt. Secure the vacuum fan seal bracket.

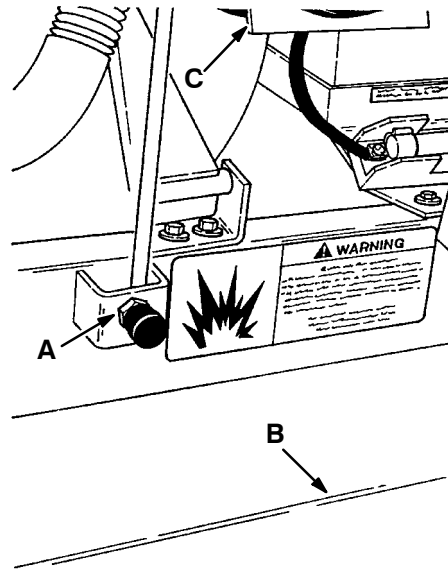

**A. Stop Bolt  
B. Hopper  
C. Vacuum Fan Seal Bracket**

03541

3. Turn the filter stop bolt (A) clockwise a half turn.
4. Close the filter assembly and check the clearance between the filter cover, the hopper, and the vacuum fan seal. This can be done by placing a strip of paper between the filter cover and the hopper. When correctly adjusted, the paper will be difficult to pull out. The seal pressure should allow the hopper to float. Push the hopper down to check - it should be able to go down and return to its original position.



### THERMO-SENTRY

The Thermo-Sentry, located inside the hopper, senses the temperature of the air pulled up from the hopper. If there is a fire in the hopper, the Thermo-Sentry stops the vacuum fan and cuts off the air flow. Press the button to reset the Thermo-Sentry.

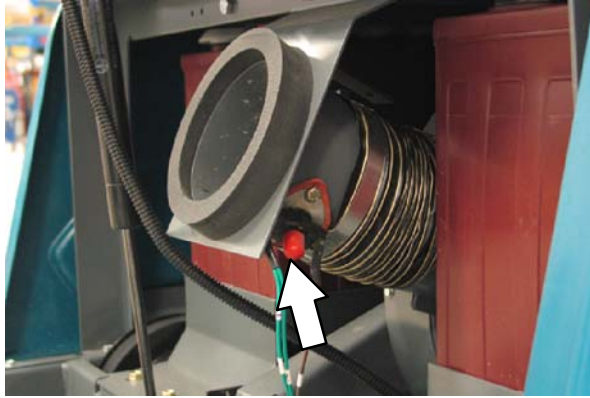

### DUST FILTER

The dust filter is located inside the dust filter compartment. The filter shaker will shake the filter for 20 seconds when the machine is powered off. Inspect and clean or replace the dust filter after every 100 hours of operation.

*NOTE: The filter shaker override switch must be in the "on" position to automatically shake the dust filter when the machine is turned off. The filter shaker override switch should be in the "on" position for most operations.*

Use one of the following methods to clean the dust filter:

- TAP - Tap the filter gently on a flat surface with the dirty side down. Do not damage the edges of the filter element or the filter will not seat properly in the filter frame.
- AIR - Blow compressed air, 240 kPa (35 psi) maximum, through the dust filter opposite the direction of the arrows on the side of the filter. This may be done with the filter in the machine. Always wear eye protection when using compressed air.

**FOR SAFETY: When servicing machine, wear eye and ear protection when using pressurized air or water.**

### REMOVING THE DUST FILTER

**FOR SAFETY: Before leaving or servicing machine; stop on level surface, set parking brake, and turn off machine.**

1. Loosen the six front filter cover screws and remove the front filter cover.
2. Remove the filter hold-down plate. Remove the dust filter.



3. Inspect and clean or replace the dust filter.

### INSTALLING THE DUST FILTER

1. Position the dust filter in the filter frame with the arrows on the side of the filter pointing away from the machine.
2. Position the filter hold-down plate on the filter.
3. Secure the front filter cover on the filter frame with the six front filter cover screws.



**SKIRTS AND SEALS**

**HOPPER LIP SKIRT**

The hopper lip skirt is located on the lower rear of the hopper. The hopper lip skirt should be inspected for wear or damage daily.

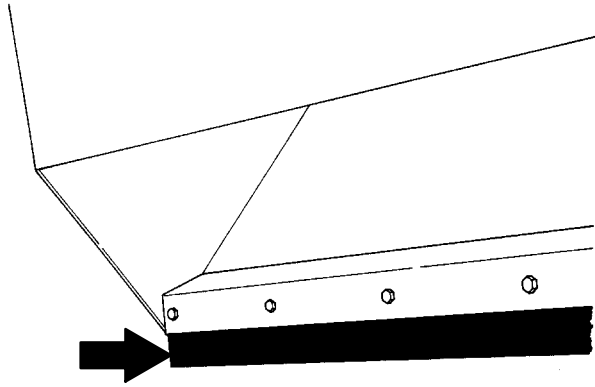

02348

**REAR BRUSH SKIRTS**

The rear brush skirts are located on the bottom rear of the brush compartment. The rear brush skirts should clear the floor by 2 mm (0.06 in). Inspect the skirt for wear or damage and proper floor clearance daily.

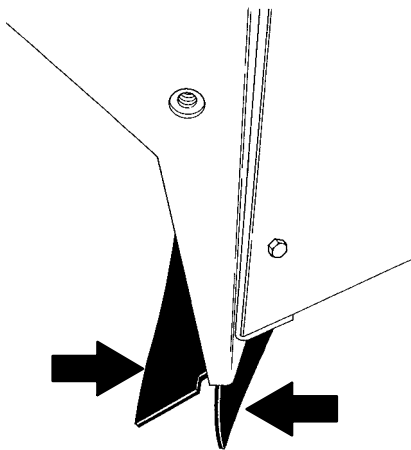

03157

**HOPPER TOP SEAL**

The hopper top seal is located on the front edge of the machine frame. Inspect the seal for wear or damage daily.

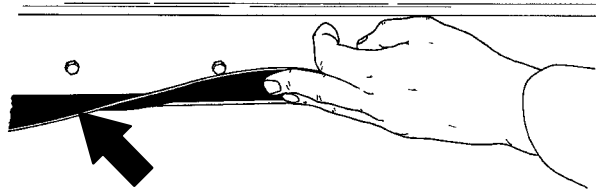

02349

**MAIN BRUSH SKIRTS AND SEALS**

The right side seal (not shown) is mounted to the machine frame. The left side seal is mounted to the main brush access door. The main brush door seal is mounted to the door. Inspect the seals for damage and wear daily. The main brush skirts should clear the floor by 2 mm (0.06 in). Inspect the skirts for damage and wear and proper floor clearance daily.

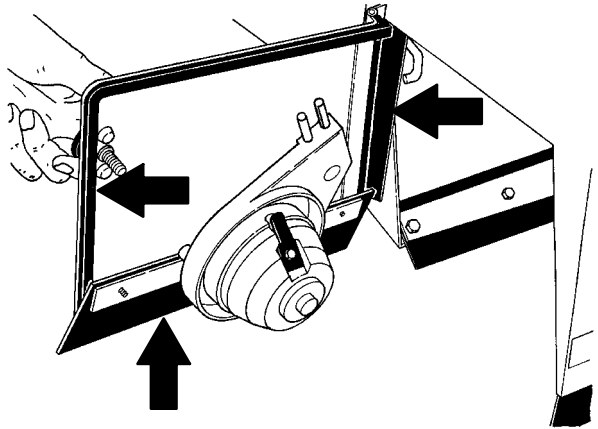

02347

# MAINTENANCE

## PROPEL HANDLE ASSEMBLY

### ADJUST PROPEL HANDLE ASSEMBLY HEIGHT

The propel handle assembly height is adjustable.

**FOR SAFETY: Before leaving or servicing machine; stop on level surface, set parking brake, and turn off machine.**

1. Remove the battery compartment covers and the rear cover. Set the covers and hardware aside.

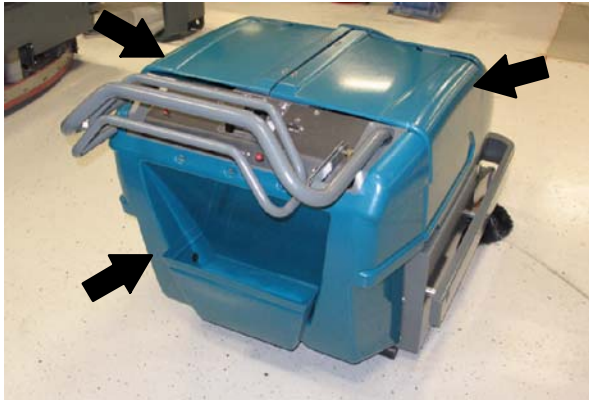

2. Slide the sleeve of the ball joint down and disconnect the ball joint from the propel handle assembly.



3. Remove the hardware holding the propel handle assembly to the frame of the machine. Set the hardware aside.

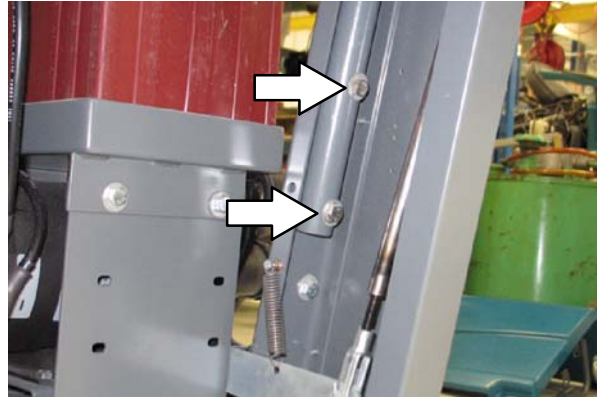

4. Raise or lower the propel handle assembly to the desired height.
5. Align the holes in the propel handle assembly with the holes in the frame of the machine and reinstall the hardware to secure the handles into place.
6. Loosen the lock nut and turn the ball joint until the propel rod assembly is at the correct length to be reinstalled onto the propel handle assembly. Tighten the lock nut.

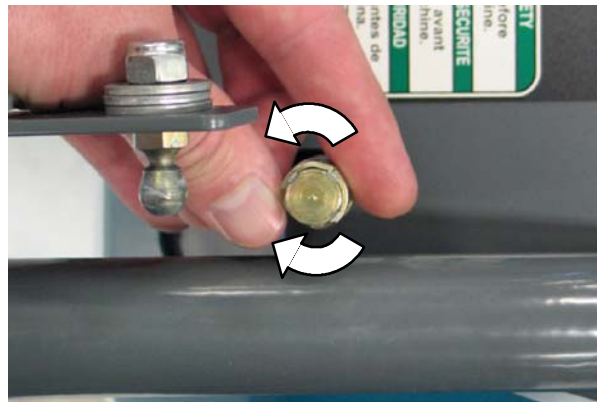

7. Reattach the ball joint to the propel handle assembly.
8. Start and test the machine. Squeeze both propel handles to ensure the machine moves in both directions.
9. Reinstall the rear cover and battery compartment covers.

**TRANSPORTING AND STORING THE MACHINE**

**TRANSPORTING THE MACHINE**

1. Position the front of the machine at the loading edge of the truck or trailer.

**FOR SAFETY: Use Truck Or Trailer That Will Support The Weight Of The Machine.**

*NOTE: Empty the hopper before transporting the machine.*

2. Block the machine tires. Tie down the machine to the truck or trailer before transporting.
3. Secure the front of the machine by routing straps through the tie down holes and fastening it to the truck or trailer.

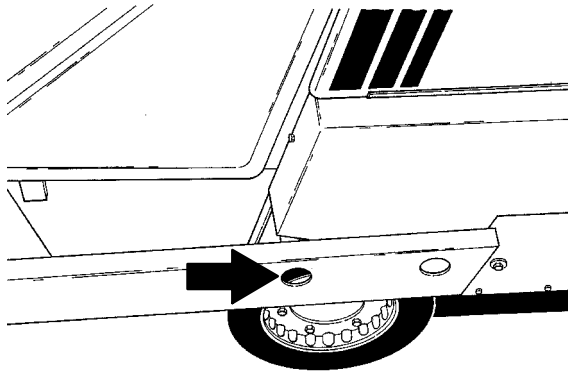

4. Secure the rear of the machine by wrapping straps around the stationary handle and fastening them to the truck or trailer.

03136

**STORING MACHINE**

When storing the machine for extended periods of time, the following procedures must be followed to lessen the chance of rust, sludge, or other undesirable deposits from forming.

1. Empty debris hopper.
2. Raise the main brush and side brush.
3. To prolong life of the batteries, leave charger plugged into the outlet. Be sure to remove the covers from the battery compartment.

**⚠ WARNING: Fire Or Explosion Hazard. Batteries emit hydrogen gas. Keep sparks and open flame away. Keep battery compartment open when charging.**

4. Park the machine in a cool, dry area.

**ATTENTION: Do not expose machine to rain, store indoors.**

# SPECIFICATIONS

## SPECIFICATIONS

### GENERAL MACHINE DIMENSIONS/CAPACITIES

Item	Dimension/capacity
Length	1570 mm (62 in)
Height (maximum)	990 mm-1120 mm (39 in-44 in)
Width (with out side brush)	920 mm (36.25 in)
Track-front	790 mm (31 in)
Wheel base	595 mm (23.5 in)
Main brush width	660 mm (26 in)
Main brush diameter	255 mm (10 in)
Side brush diameter	430 mm (17 in)
Sweeping path width (with side brush)	860 mm (34 in)
Hopper volume capacity	0.08 m <sup>3</sup> (2.8 cu ft)
Hopper weight capacity	68 kg (150 lb)
GVWR	345 kg (760 lb)
Dust filter (pleated panel filter element)	4.55 m <sup>2</sup> (49 sq. ft)
Operating sound level at operator ear	76 dB(A)
Vibration level at propel control handles	2.5 m/s <sup>2</sup>

### GENERAL MACHINE PERFORMANCE

Item	Measure
Turning radius	1730 mm (68 in)
Travel speed forward (maximum)	4.7 Km/h (2.9 mph)
Travel speed reverse (maximum)	4.5 Km/h (2.8 mph)
Maximum rated climb angle	8°/14%
Maximum rated descent angle	6°/10.5%

### POWER TYPE

System	Drive Type
Propelling	Belt to chain
Differential	Belt
Wheel Drive	Chain
Main Brush	Belt
Side Brush	Belt
Vacuum Fan	Belt

Type	VDC	amp	Hz	Phase	VAC
Charger: Auto / Selectable AC Voltage Input	24	11	50/60	1	100-240

Type	Use	VDC	kW (hp)
Electric Motor	Propelling	24	0.75 (1)

Type	Quantity	Volts	Ah Rating	Weight
Batteries	2	12	155 @ 20 hr rate	38 kg (83 lb)

**TIRES**

Location	Type	Size
Front (2)	Solid	250 mm x 51 mm (10 in x 2 in)
Rear (1)	Solid	130 mm x 38 mm (5 in x 1.5 in)

**MACHINE DIMENSIONS**

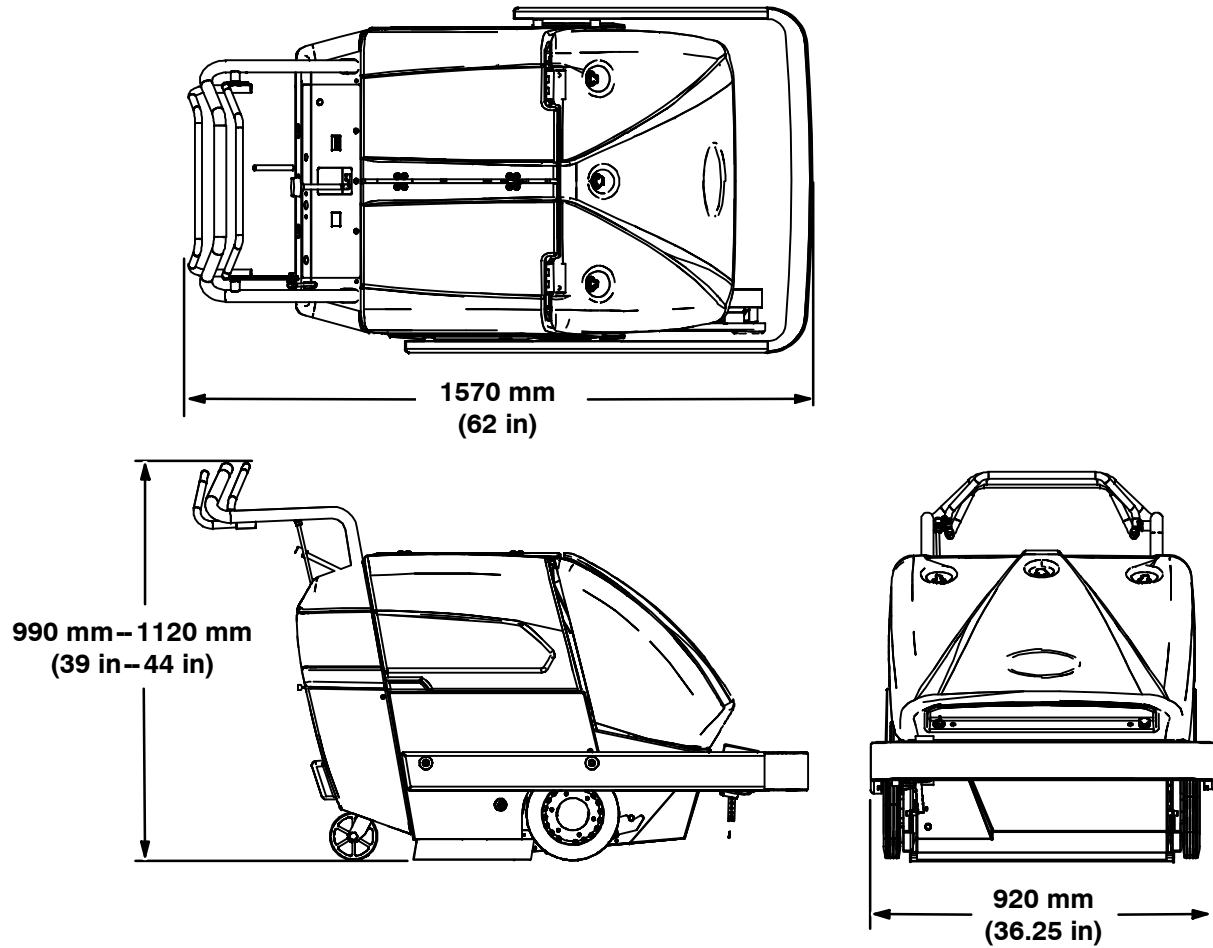

03131

**A**

Adjusting the dust filter to hopper sealing, 29  
Adjusting the hopper floor clearance, 29  
Adjusting the main brush pattern, 27  
Adjusting the propel handle assembly, 32  
Adjusting the propelling belt tension , 23  
Adjusting the side brush, 28  
Adjusting the side brush belt tension , 24  
Adjusting the vacuum fan belt tension , 25  
Arm, side brush, 10

**B**

Batteries, 20  
  Charging the batteries, 21  
  Check Electrolyte Level, 20  
  Clean Batteries, 20  
  Disposing Batteries, 20  
  Lead acid, 20  
  Measure Specific Gravity, 20  
Battery charge indicator, 8  
Battery charger panel, 8  
Belts, 23  
  Main brush belt, 25  
  Propelling belts, 23  
  Side brush belt, 24  
  Vacuum fan belt, 25  
Brakes, parking, 10  
Brush arm pivots, 18  
Brush Information, 11  
Brushes, 26  
  Main brush, 26  
  Side brush, 28

**C**

Capacities, 34  
Chain, static drag, 26  
Chains  
  Static drag chain, 26  
  Wheel drive chains, 26  
Check Electrolyte Level (Batteries), 20  
Check Specific Gravity (Batteries), 20  
Checking and adjusting the hopper floor clearance, 29

Checking and adjusting the main brush pattern, 27  
Checking and adjusting the propelling belt tension , 23  
Checking and adjusting the side brush belt tension , 24  
Checking and adjusting the vacuum fan belt tension, 25  
Checking the main brush belts , 25  
Checking the wheel drive chain tension , 26  
Circuit breakers, 11  
Circuit breakers and fuses, 11  
Clean Batteries, 20  
Cleaning the dust filter, 30  
Control handles, propel, 7  
Controls  
  Filter shaker override switch, 7  
  Main brush lever, 9  
  On-off key switch, 12  
  Parking brake lever, 10  
  Propel control handles, 7  
  Side brush arm, 10  
Controls and Instruments, 6

**D**

Debris hopper, 29  
  Adjusting the dust filter to hopper sealing, 29  
  Checking and adjusting the hopper floor clearance, 29  
Debris hopper and dust filter, 29  
Differential, 18  
Dimensions, 34  
Disposing Batteries, 20  
Drive chains, 18  
Dust filter, 30  
  Cleaning the dust filter, 30  
  Installing the dust filter, 30  
  Removing the dust filter, 30

**E**

Electric Motors, 23  
Electrical system  
  Batteries, 20  
  Charging the batteries, 21  
Emptying the hopper, 13

**F**

Filter shaker override switch, 7  
Fuses, 11

**H**

Hopper lip skirt, 31  
Hopper top seal, 31  
Hour meter, 9

**I**

Indicator, battery control, 8  
Indicators  
    Battery control indicator, 8  
    Hour meter, 9  
Inspect the debris hopper, 29  
Inspect the dust filter, 30  
Inspect the main brush, 26  
Inspect the side brush, 28  
Installing the dust filter, 30  
Installing the main brush, 26  
Installing the side brush, 28

**K**

Key switch, on-off, 12

**L**

Labels, 3  
    Control symbols, 5  
    Safety labels, 3  
Lead Acid Batteries, 20  
Lever, main brush, 9  
Lever, parking brake, 10  
Lubrication, 18  
    Brush arm pivots, 18  
    Differential, 18  
    Drive chains, 18  
    Rear caster, 18  
    Self adjusting sheave, 19  
    Side brush gear box, 19

**M**

Machine components, 4  
Machine dimensions, 35  
Machine Operation, 12  
    Emptying the hopper, 13  
    Pre-Operation Checklist, 12  
    Removing the hopper, 14  
    Sweeping, 12  
Machine Performance  
    Travel Speed (Maximum), 34  
    Turning radius, 34  
Machine Specifications, 34  
Machine Troubleshooting, 15  
Main brush, 26  
    Checking and adjusting the main brush pattern, 27  
    Installing the main brush, 26  
    Removing the main brush, 26  
Main brush belt, Checking the main brush belts , 25  
Main brush down position, 9  
Main brush free-float position, 9  
Main brush lever, 9  
Main brush positions  
    Main brush down position, 9  
    Main brush free-float position, 9  
    Main brush up position, 9  
Main brush skirts and seals, 31  
Main brush up position, 9  
Maintenance, 16  
    Batteries, 20  
    Belts and Chains, 23  
    Brushes, 26  
    Debris hopper and dust filter, 29  
    Electric motors, 23  
    Lubrication, 18  
    Skirts and seals, 31  
Maintenance Chart, 16  
Meter, hour, 9  
Motors, Electric motors, 23

**O**

- On-off key switch, 12
- Operating the machine
  - Emptying the hopper, 13
  - Removing the hopper, 14
  - Sweeping, 12
- Operation, 4
- Operation of controls, 7
- Options, Parking brake lever, 10

**P**

- Parking brake lever (Option), 10
- Power type, Specifications, 34
- Pre-Operation Checklist, 12
- Propel control handles, 7
- Propel handle assembly, 32
  - Adjusting the propel handle assembly, 32
- Propelling belts, 23
  - Checking and adjusting the propelling belt tension , 23

**R**

- Rear brush skirts, 31
- Rear caster, 18
- Removing the dust filter, 30
- Removing the hopper, 14
- Removing the main brush, 26
- Removing the side brush, 28

**S**

- Safety
  - Labels, 3
  - Precautions, 2
- Self adjusting sheave, 19
- Side brush, 28
  - Adjusting the side brush, 28
  - Installing the side brush, 28
  - Removing the side brush, 28
- Side brush arm, 10
- Side brush belt, Checking and adjusting the side brush belt tension , 24

- Side brush gear box, 19
- Skirts and Seals, 31
  - Hopper lip skirt, 31
  - Hopper top seal, 31
  - Main brush skirts and seals, 31
  - Rear brush skirts, 31
- Specifications, 34–37
  - Machine Capacities, 34
  - Machine Dimensions, 34
  - Machine Performance, 34
  - Power type, 34
  - Tires, 35
- Static drag chain, 26
- Storing the machine, 33
- Sweeping, 12
- Symbol definitions, 5

**T**

- Thermo-Sentry, 30
- Tires, Specifications, 35
- Transporting and Storing the Machine, 33
- Transporting the machine, 33
- Troubleshooting, 15
- Turn machine off, 13
- Turn machine on, 12

**V**

- Vacuum fan belt, Checking and adjusting the vacuum fan belt tension , 25

**W**

- Wheel drive chains, Checking the wheel drive chain tension , 26