

Parts List For:

AHC-10E	PE552S-C	PE554C-C
PE552	PE553	PE554PT
PE552-C	PE553-C	PE554S
PE552A	PE554	PE554S-BOLT
PE552A-C	PE554-C	PE554S-C
PE552S	PE554C	PE554T
		PE554T-C

**MODEL C
 (MODEL A FOR AHC-10E)
 ELECTRIC TWO-STAGE HYDRAULIC PUMP
 GENERAL SECTION**

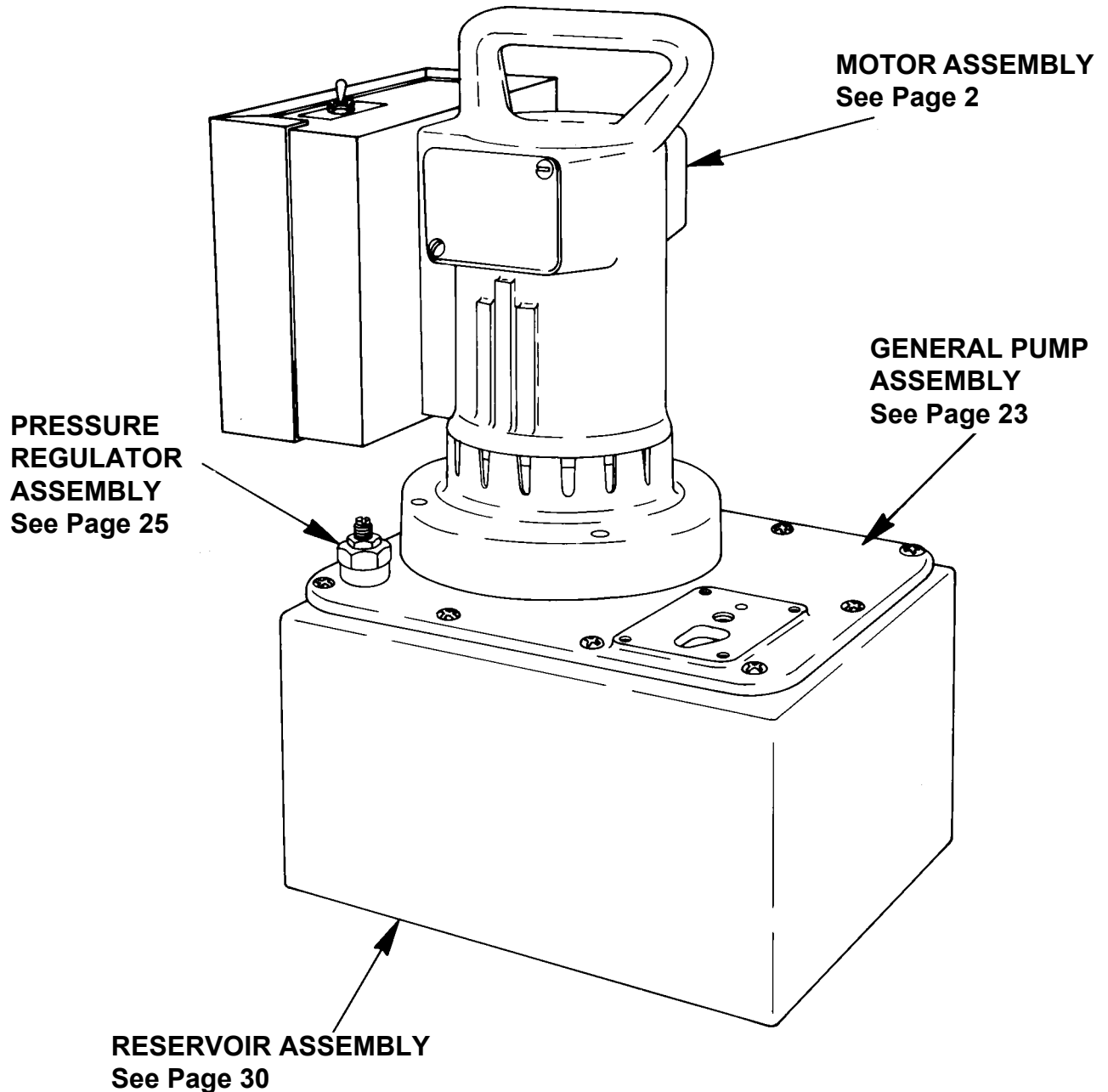

PART LIST

UNIVERSAL MOTOR

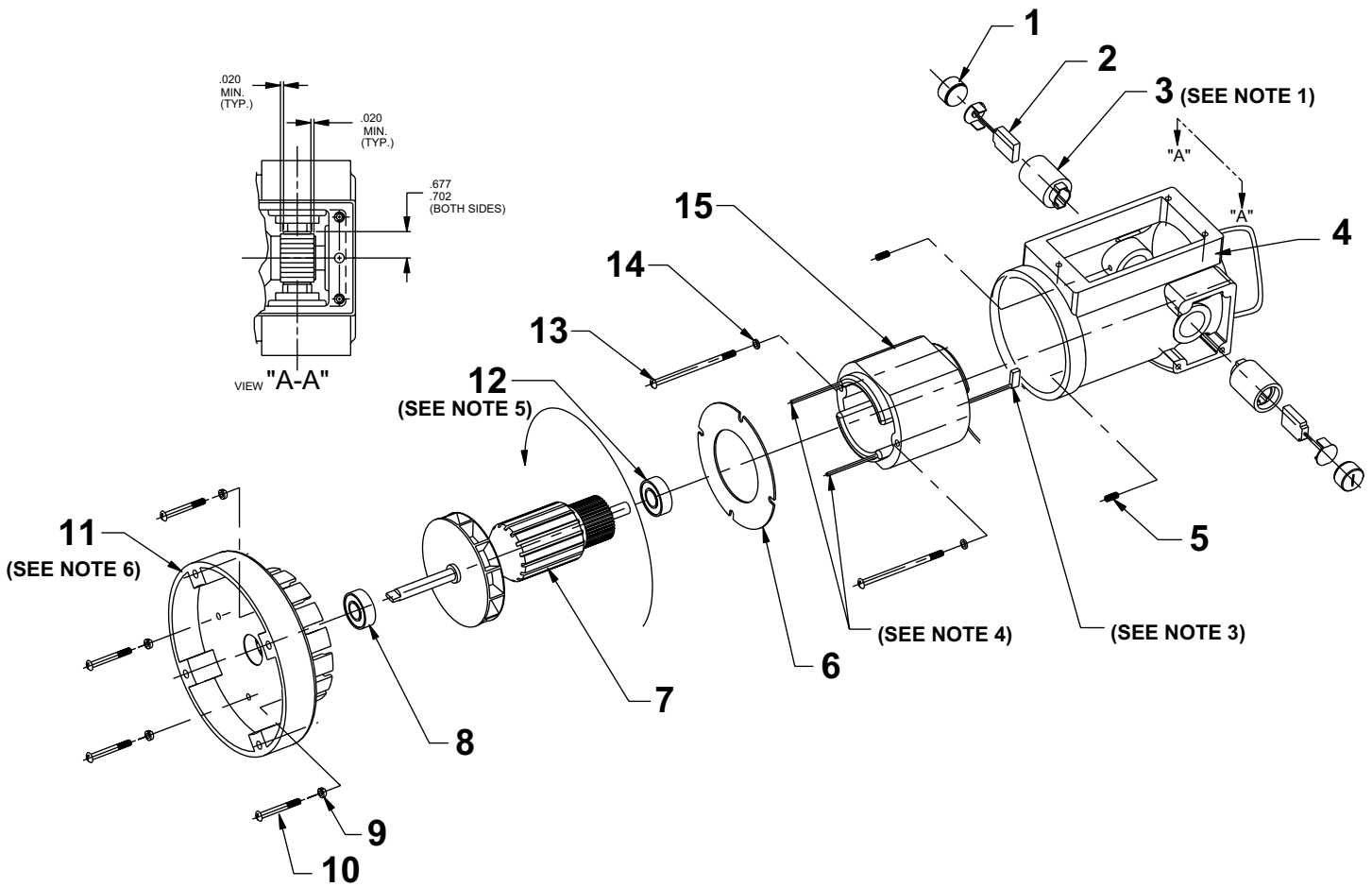

ITEM	PART NO.	DESCRIPTION	QTY.
1	10806	BRUSH HOLDER CAP	2
2	10804	BRUSH (110 V.)	2
	2001708	BRUSH ASSEMBLY (220 V.)	2
3	10805	BRUSH HOLDER	2
4	61901WH2	MOTOR SHELL	1
5	10133	SCREW (#10-24 UNC X 1/4 LG.)	2
6	20786	BAFFLE PLATE	1
7	10800	ARMATURE (115 V.)	1
	*58841A	ARMATURE (230 V.)	1
8	10439	BALL BEARING	1
9	10241	LOCKWASHER (FOR #10 BOLT)	4
10	10169	SCREW (#10-24 UNC X 2" LG.; TORQUE TO 20/25 IN. LBS.)	4
11	351416WH2	MOTOR BASE	1
12	10438	BALL BEARING	1

Parts List Continued

ITEM	PART NO.	DESCRIPTION	QTY.
13	10170	SCREW (#10-24 UNC X 3-1/4 LG.)	2
14	12356	WASHER (#10 INTERNAL TOOTH)	2
15	10802	FIELD (115 V.)	1
	*58841F	FIELD (230 V.)	1
<p>* If replacing the field or armature on 230 V. motors, order kit no. 252311.</p>			

NOTES:

1. Brush holders (Item #3) must be installed with slot and dimple facing the open end of the motor shell casting.
2. Stator must be installed with part no. And date code up (must be visible through the rectangular opening in the motor shell casting).
3. Insert flag terminals into adjacent brush holders.
4. Line leads must be routed through the rectangular opening in the motor shell casting.
5. Press bearings into armature and install as a unit into the motor shell casting.
6. Casting number must be on top when the motor base casting is fastened to the motor shell casting.

MOTOR ASSEMBLY- MANUAL & AUTO OPEN/TANDEM CENTER VALVES

(FOR PE552, PE552-C, PE552A, PE552A-C, PE553, PE553-C, PE554, PE554-C, PE554PT, PE554T & PE554T-C)

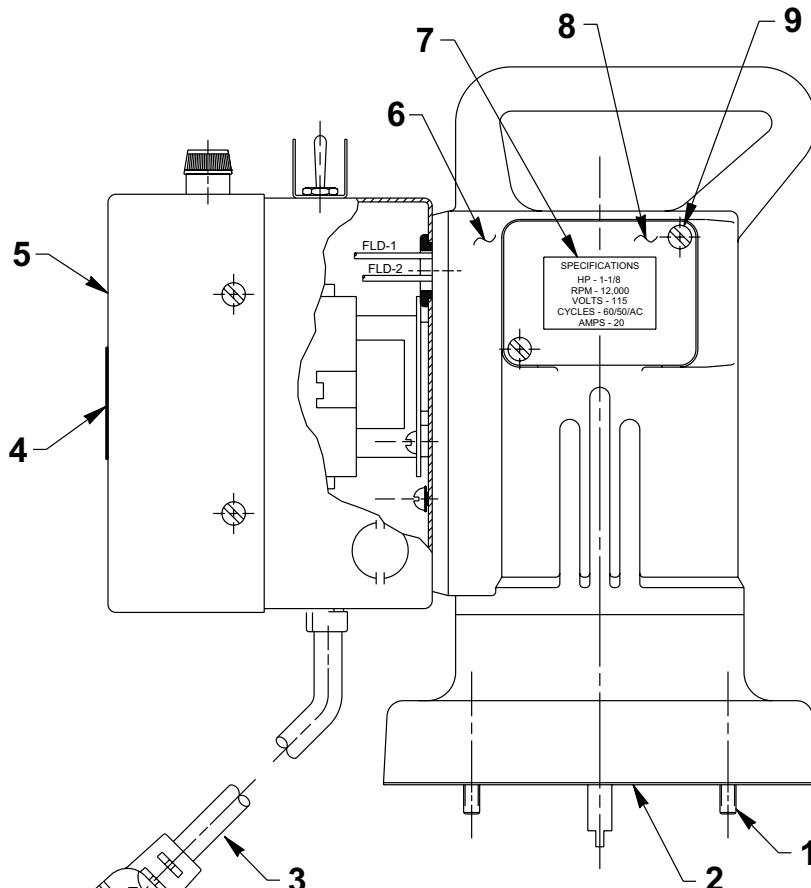
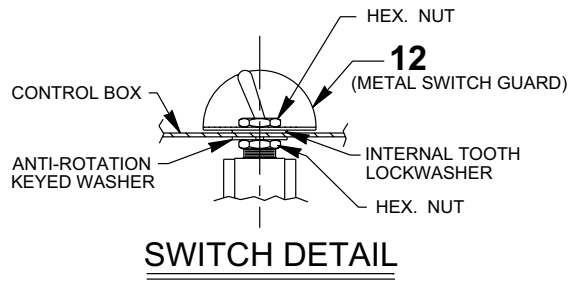
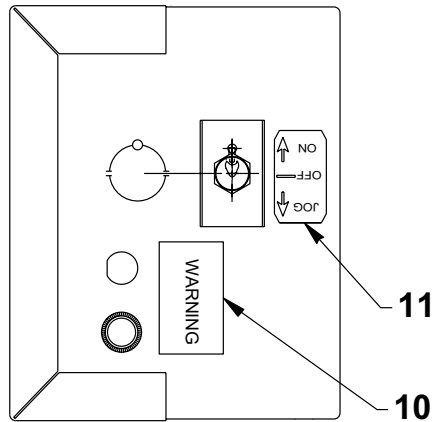

This style plug is used for PE552-C, PE552A-C, PE553-C, PE554T-C & PE554-C.

Parts List Continued

ITEM	PART NO.	DESCRIPTION	QTY.
1	10022	SCREW (1/4-20 X 1-1/2 LG.)	4
2	30650	MOTOR BASE GASKET	1
3	307440	CORD (8 FT. LG.; 115 V. 12/3 SJTO; FOR PE552, PE552A, PE553, PE554, PE554T & PE554PT)	1
	350155	CORD (8 FT. LG.; 115 V. 12/3 SJTO; FOR PE552-C, PE552A-C, PE553-C, PE554-C & PE554T-C)	1
4	200188	DECAL (WARNING/IMPORTANT)	1
5	43126WH2	CONTROL BOX COVER	1
6	53338	UNIVERSAL MOTOR ASSEMBLY (110/115 V.,50/60 HZ.; SEE PAGE 2)	1
7	215164	SPECIFICATIONS DECAL	1
8	21008	COVER	2
9	11539	SCREW (10-24 X 1/4 LG.)	4
10	252305	WARNING DECAL	1
11	352080	DECAL (ON/OFF/JOE)	1
12	352061	METAL SWITCH GUARD	1

ELECTRICAL SCHEMATIC - MANUAL AND AUTO OPEN/TANDEM CENTER VALVES 115 V., 60 Hz.

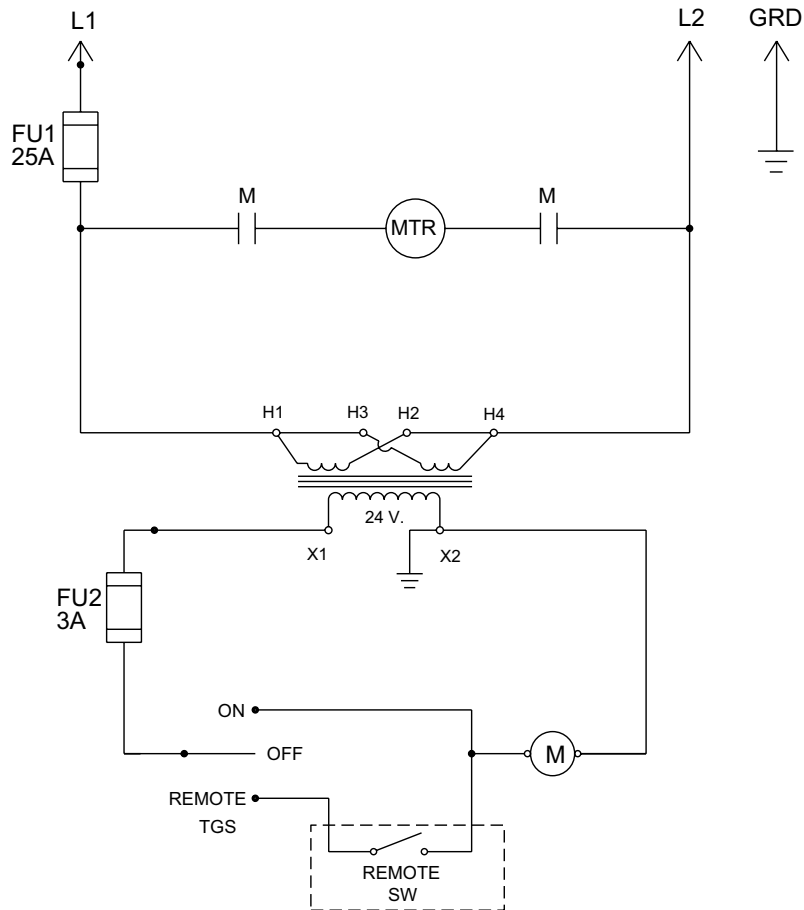

Parts List Continued

⚠ WARNING : To help avoid personal injury, all electrical work must be done by a qualified electrician.

North American and International Color Codes

Conductors	North American	International
Line	Black	Brown
Neutral	White	Blue
Ground.....	Green.....	Green/Yellow

MOTOR CONTROL BOX - MANUAL AND AUTO OPEN/TANDEM CENTER VALVES

(FOR PE552, PE552-C, PE552A, PE552A-C, PE553, PE553-C,
PE554, PE554-C, PE554PT, PE554T & PE554T-C)

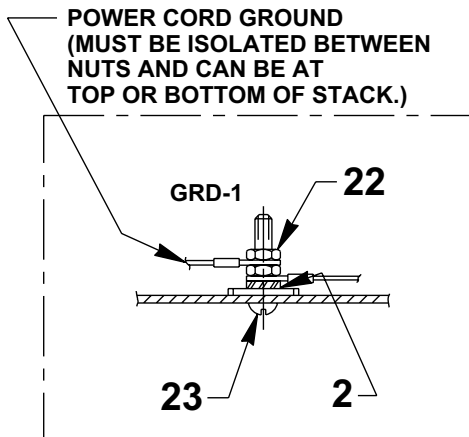

NOTE: SERRATED LOCK WASHER
MUST BE ADJACENT TO
METAL BOX. MORE WASHERS
CAN BE USED IF DESIRED.

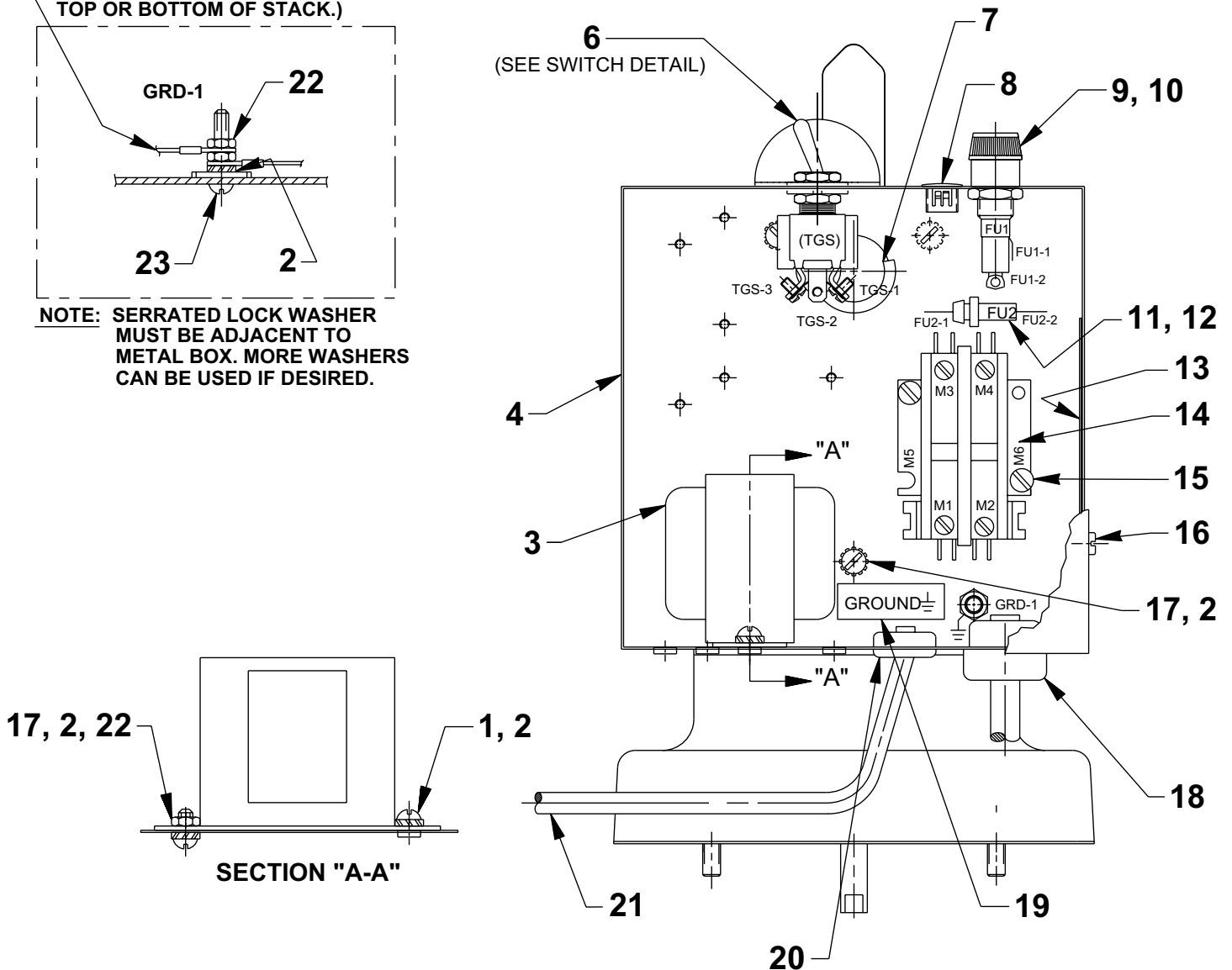

Parts List Continued

ITEM	PART NO.	DESCRIPTION	QTY.
1	11539	SCREW (10-24 X 1/4 LG.)	1
2	11108	EXTERNAL TOOTH WASHER (.40 X .20)	6
3	11852	TRANSFORMER	1
4	65264WH2	ELECTRICAL CONTROL BOX	1
6	12665	TOGGLE SWITCH	1
7	15497	RUBBER GROMMET	1
8	17782	SNAP PLUG	1
9	18292	FUSE HOLDER	1
10	252289	FUSE (25 AMP 125 V.)	1
11	16887	FUSE HOLDER	1
12	206962	FUSE (3 AMP 250 V.)	1
13	250150	WARNING DECAL	1
14	420718-4	CONTACTOR	1
15	10166	SCREW (10-24 X 1/2 LG.)	2
16	14812	SCREW (8-18 X 3/8 LG.)	4
17	10164	SCREW (10-24 X 3/8 LG.)	4
18	210112	STRAIN RELIEF BUSHING	1
19	205189	DECAL (GROUND)	1
20	15993	STRAIN RELIEF BUSHING	1
21	25017	HAND SWITCH ASSEMBLY (SEE PARTS LIST NO. 101644)	1
22	10197	HEX NUT (10-24)	3
23	11856	SCREW (10-24 X 1" LG.)	1

MOTOR ASSEMBLY- 2-WAY SOLENOID VALVES (FOR PE552S-C & PE552S)

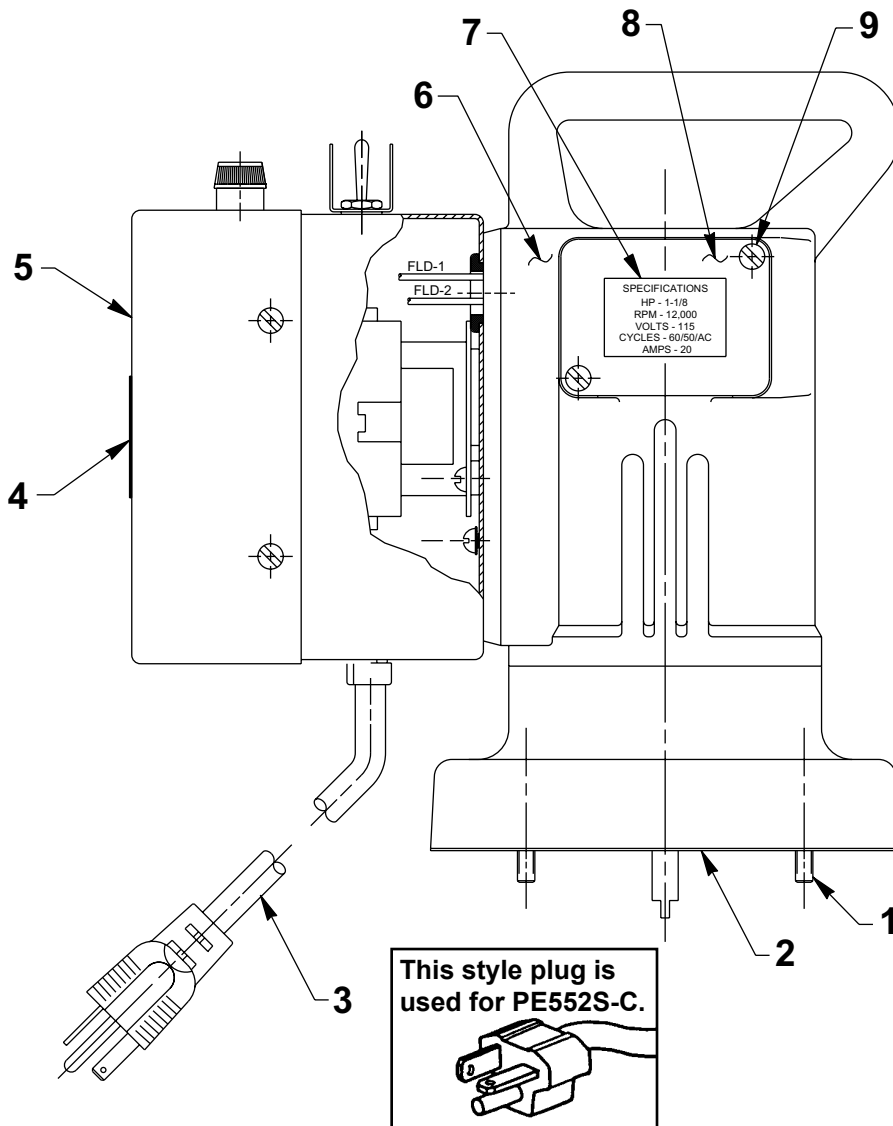
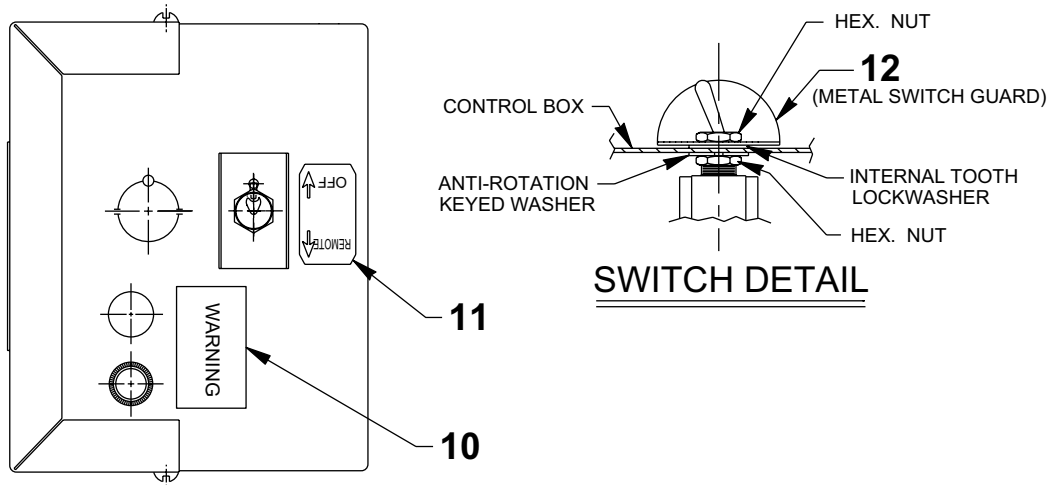

Parts List Continued

ITEM	PART NO.	DESCRIPTION	QTY.
1	10022	SCREW (1/4-20 X 1-1/2 LG.)	4
2	30650	MOTOR BASE GASKET	1
3	307440	CORD (8 FT. LG.; 115 V. 12/3 SJTO; FOR PE552S)	1
	350155	CORD (8 FT. LG.; 115 V. 12/3 SJTO; FOR PE552S-C)	1
4	200188	DECAL (WARNING/IMPORTANT)	1
5	43126WH2	CONTROL BOX COVER	1
6	53338	UNIVERSAL MOTOR ASSEMBLY (110/115 V. 50/60 HZ.;SEE PAGE 2)	1
7	215164	SPECIFICATIONS DECAL	1
8	21008	COVER	2
9	11539	SCREW (10-24 X 1/4 LG.)	4
10	252305	WARNING DECAL	1
11	360069	DECAL (REMOTE/OFF)	1
12	352061	METAL SWITCH GUARD	1

ELECTRICAL SCHEMATIC - 2-WAY SOLENOID VALVES 115 V., 60 Hz.

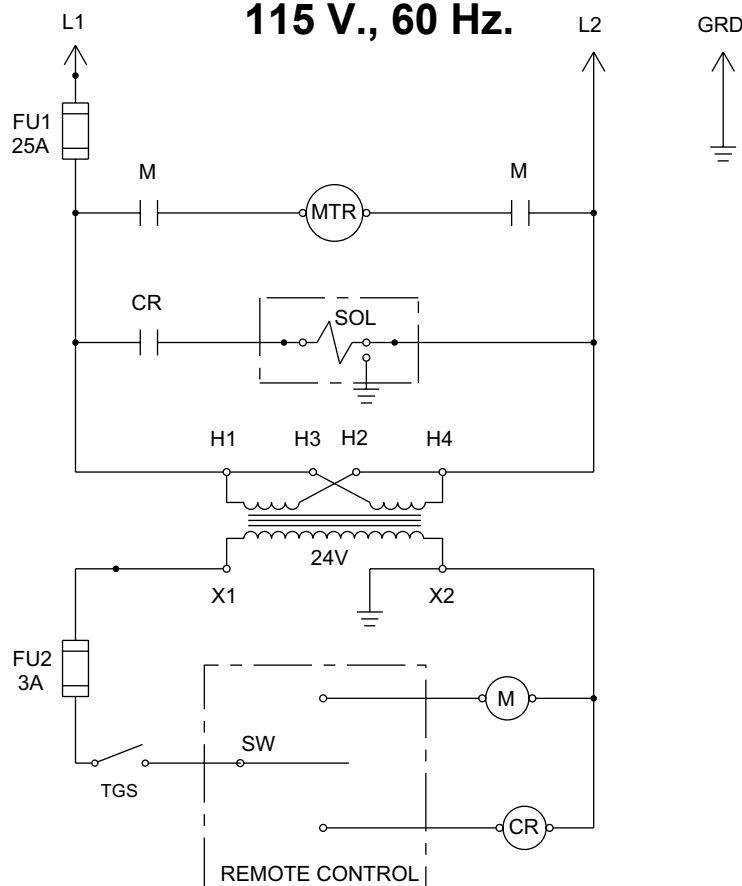

WARNING : To help avoid personal injury, all electrical work must be done by a qualified electrician.

North American and International Color Codes

Conductors	North American	International
Line	Black	Brown
Neutral	White	Blue
Ground.....	Green	Green/Yellow

Parts List Continued

**MOTOR CONTROL BOX - 2-WAY SOLENOID VALVES
(FOR PE552S-C & PE552S)**

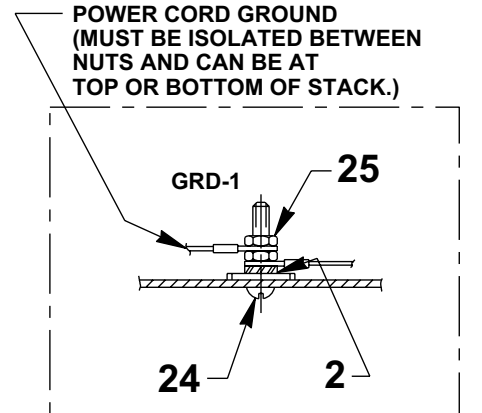
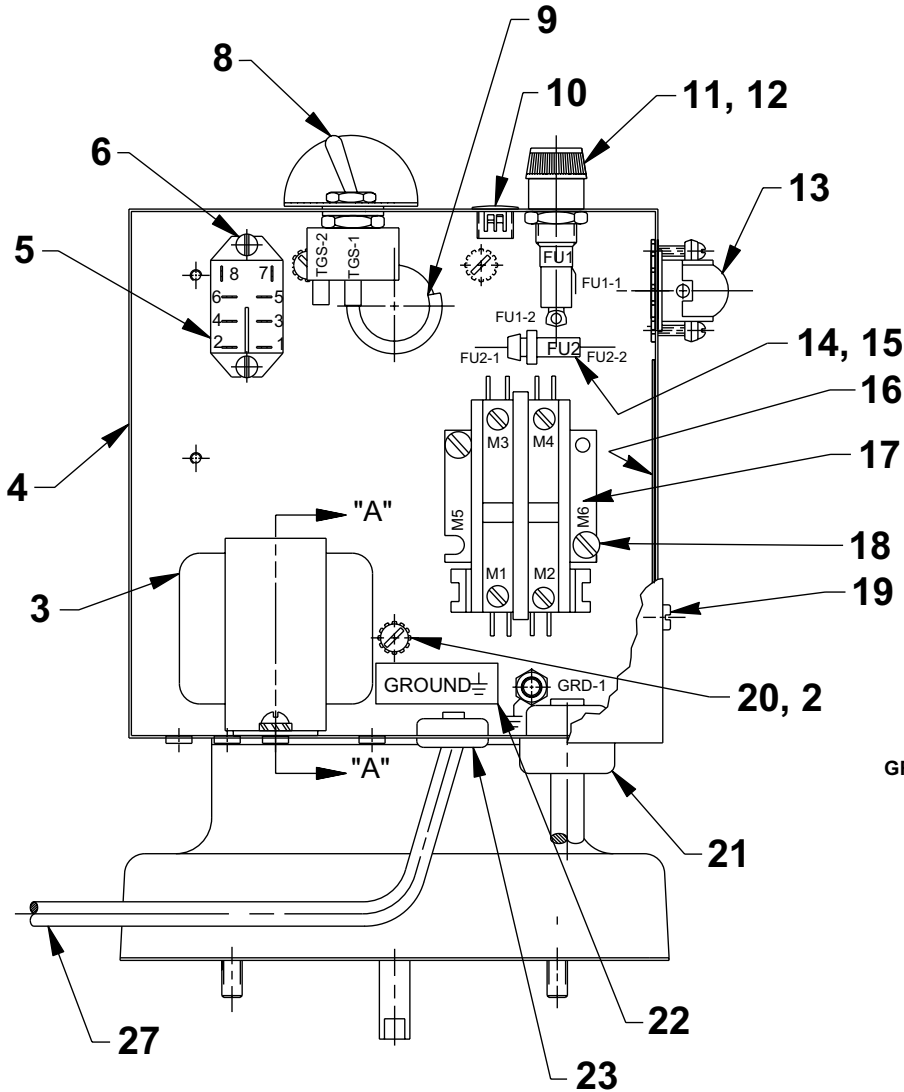

NOTE: SERRATED LOCK WASHER MUST BE ADJACENT TO METAL BOX. MORE WASHERS CAN BE USED IF DESIRED.

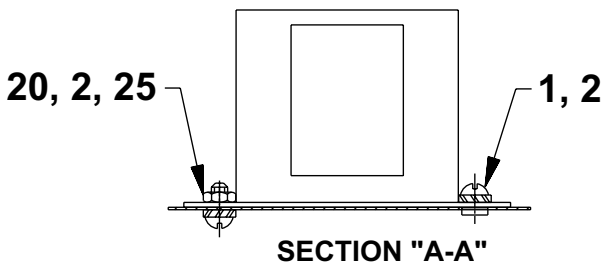
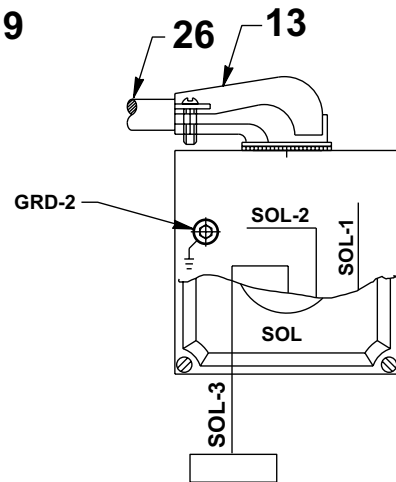

Parts List Continued

ITEM	PART NO.	DESCRIPTION	QTY.
1	11539	SCREW (10-24 X 1/4 LG.)	1
2	11108	EXTERNAL TOOTH WASHER (.40 X .20)	6
3	11852	TRANSFORMER	1
4	65264WH2	ELECTRICAL CONTROL BOX	1
5	251046	GENERAL PURPOSE RELAY	1
6	17563	SCREW (6-32 X 1/4 LG.)	2
8	12301	TOGGLE SWITCH	1
9	15497	RUBBER GROMMET	1
10	17782	SNAP PLUG	1
11	18292	FUSE HOLDER	1
12	252289	FUSE (25 AMP 125 V.)	1
13	11144	90° ELBOW CONNECTOR	2
14	16887	FUSE HOLDER	1
15	206962	FUSE (3 AMP 250 V.)	1
16	250150	WARNING DECAL	1
17	420718-4	CONTACTOR (2 POLE)	1
18	11539	SCREW (10-24 X 1/4 LG.)	2
19	14812	SCREW (8-18 X 3/8 LG.)	4
20	10164	SCREW (10-24 X 3/8 LG.)	4
21	210112	STRAIN RELIEF BUSHING	1
22	205189	DECAL (GROUND)	1
23	15993	STRAIN RELIEF BUSHING	1
24	11856	SCREW (10-24 X 1" LG.)	1
25	10197	HEX NUT (10-24)	3
26	12293	CABLE (16/3 SJTO)	2.33'
27	307491	HAND SWITCH ASSEMBLY (SEE PAGE 32)	1

MOTOR ASSEMBLY- CLOSED CENTER VALVES
(FOR PE554C & PE554C-C)

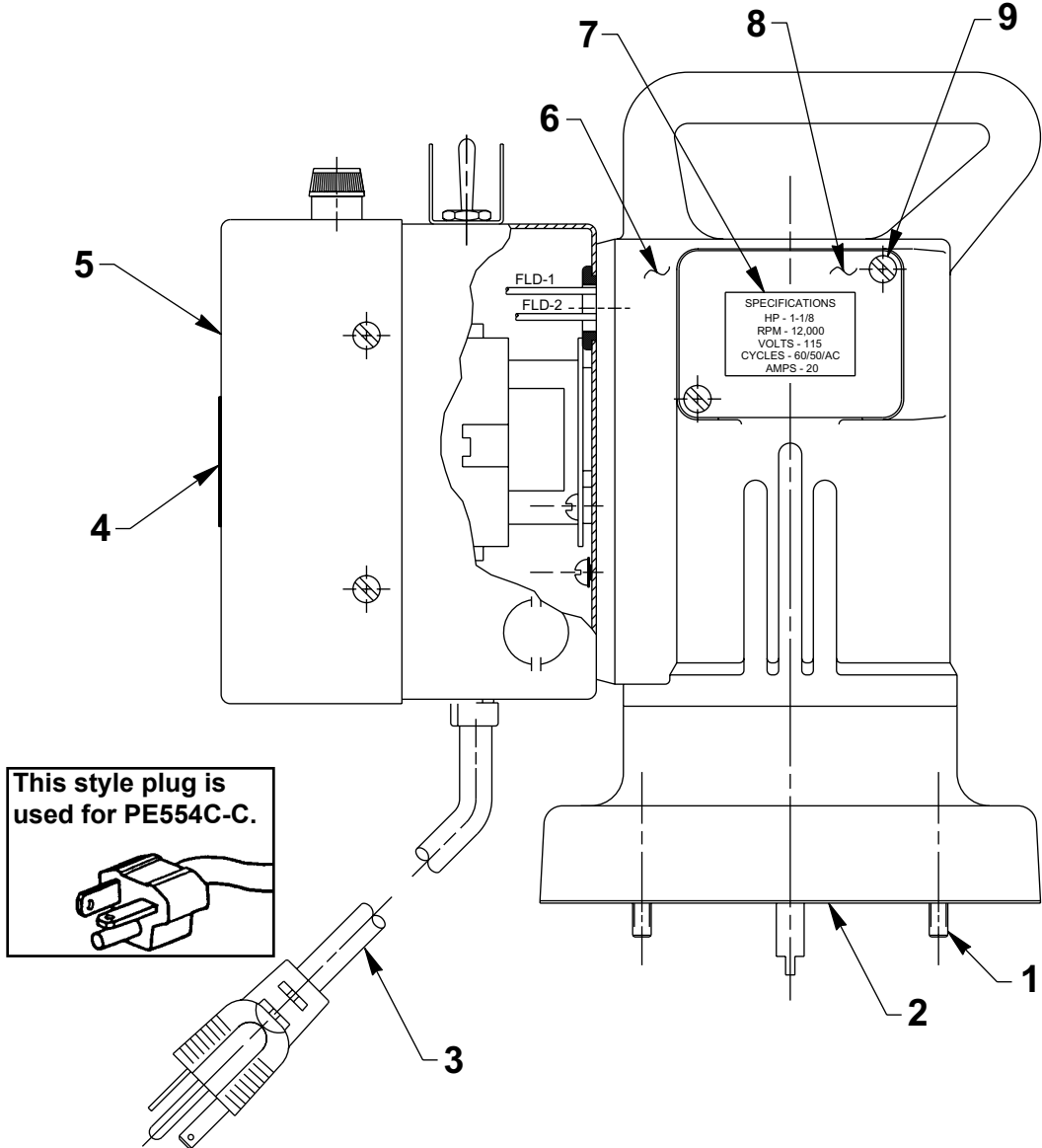
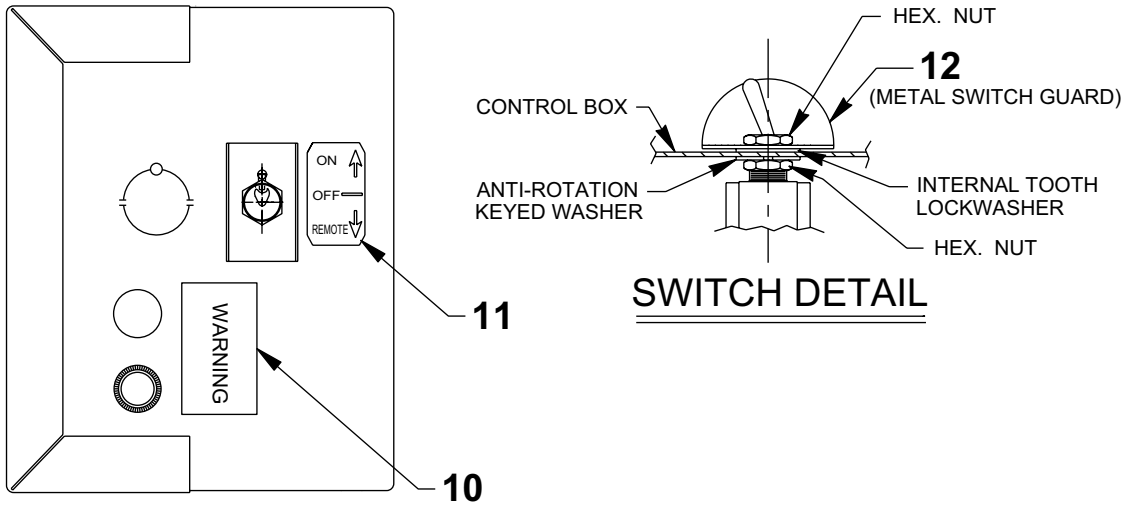

Parts List Continued

ITEM	PART NO.	DESCRIPTION	QTY.
1	10022	SCREW (1/4-20 X 1-1/2 LG.)	4
2	30650	MOTOR BASE GASKET	1
3	307440	CORD (8 FT. LG.; 115 V. 12/3 SJTO; FOR PE552S)	1
	350155	CORD (8 FT. LG.; 115 V. 12/3 SJTO; FOR PE552S-C)	1
4	200188	DECAL (WARNING/IMPORTANT)	1
5	43126WH2	CONTROL BOX COVER	1
6	53338	UNIVERSAL MOTOR ASSEMBLY (110/115 V. 50/60 HZ.; SEE PAGE 2)	1
7	215164	SPECIFICATIONS DECAL	1
8	21008	COVER	2
9	11539	SCREW (10-24 X 1/4 LG.)	4
10	252305	WARNING DECAL	1
11	352080	DECAL (ON/OFF/REMOTE)	1
12	352061	METAL SWITCH GUARD	1

ELECTRICAL SCHEMATIC - CLOSED CENTER VALVES 115 V., 60 Hz. W/24V Secondary

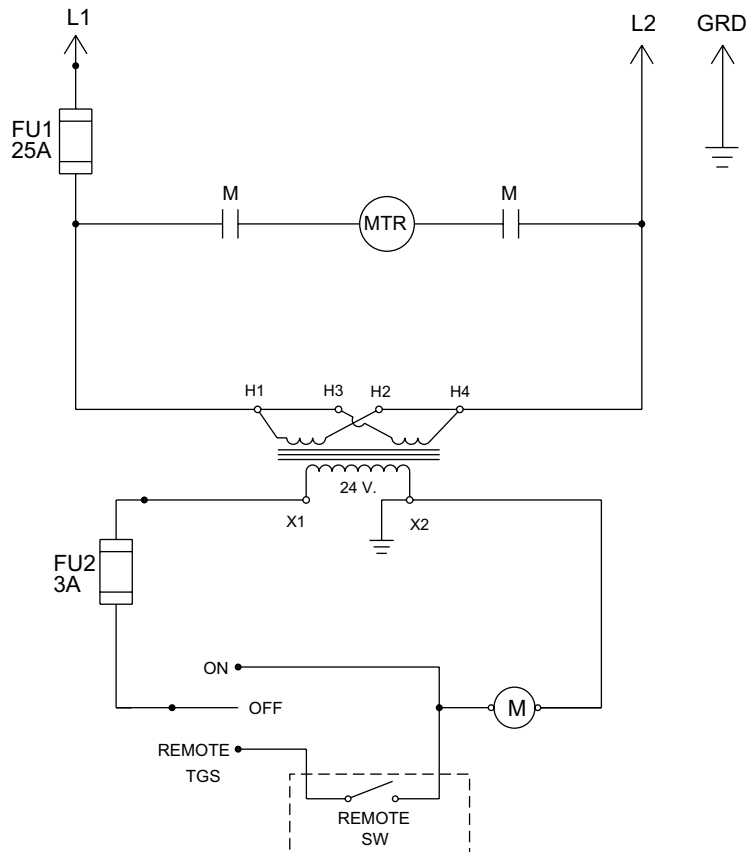

WARNING: To help avoid personal injury, all electrical work must be done by a qualified electrician.

North American and International Color Codes

Conductors	North American	International
Line	Black	Brown
Neutral	White	Blue
Ground.....	Green.....	Green/Yellow

**MOTOR CONTROL ASSEMBLY
(FOR PE554C)**

POWER CORD GROUND
(MUST BE ISOLATED BETWEEN
NUTS AND CAN BE AT
TOP OR BOTTOM OF STACK.)

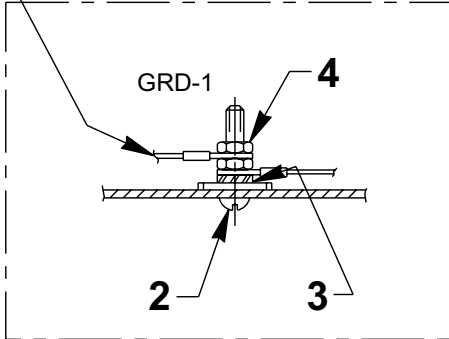

**NOTE: SERRATED LOCK WASHER
MUST BE ADJACENT TO
METAL BOX. MORE WASHERS
CAN BE USED IF DESIRED.**

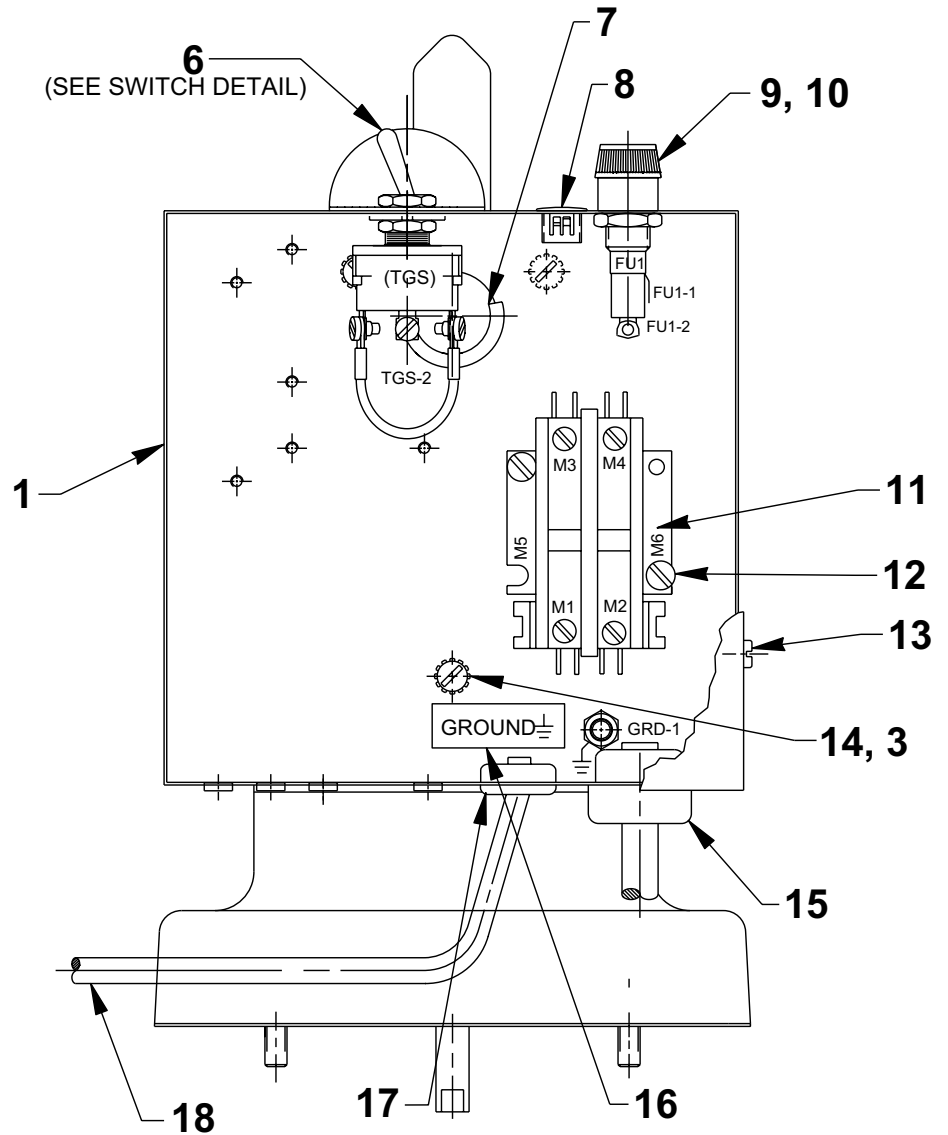

Parts List Continued

ITEM	PART NO.	DESCRIPTION	QTY.
1	65264WH2	ELECTRICAL CONTROL BOX	1
2	11856	SCREW (10-24 X 1" LG.)	1
3	11108	EXTERNAL TOOTH WASHER (.40 X .20)	6
4	10197	HEX NUT (10-24)	3
5	12665	TOGGLE SWITCH	1
6	15497	RUBBER GROMMET	1
8	17782	SNAP PLUG	1
9	18292	FUSE HOLDER	1
10	252289	FUSE (25 AMP 125 V.)	1
11	420718-1	CONTACTOR (2 POLE)	1
12	10166	SCREW (10-24 X 1/2 LG.)	3
13	14812	SCREW (8-18 X 3/8 LG.)	4
14	10164	SCREW (10-24 X 3/8 LG.)	4
15	210112	STRAIN RELIEF BUSHING	1
16	205189	DECAL (GROUND)	1
17	15993	STRAIN RELIEF BUSHING	1
18	203225	HAND SWITCH ASSEMBLY (HEAVY DUTY RUBBER; NOT SHOWN)	1

MOTOR CONTROL ASSEMBLY (FOR PE554C-C)

POWER CORD GROUND
(MUST BE ISOLATED BETWEEN
NUTS AND CAN BE AT
TOP OR BOTTOM OF STACK.)

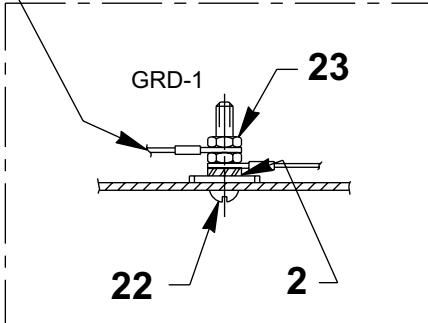

**NOTE: SERRATED LOCK WASHER
MUST BE ADJACENT TO
METAL BOX. MORE WASHERS
CAN BE USED IF DESIRED.**

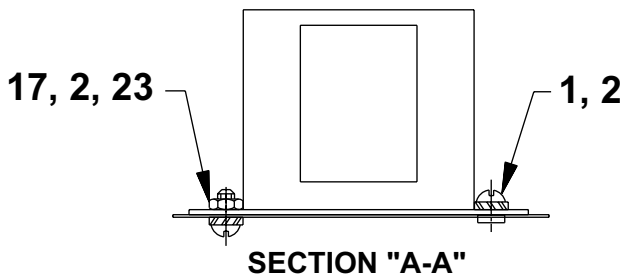
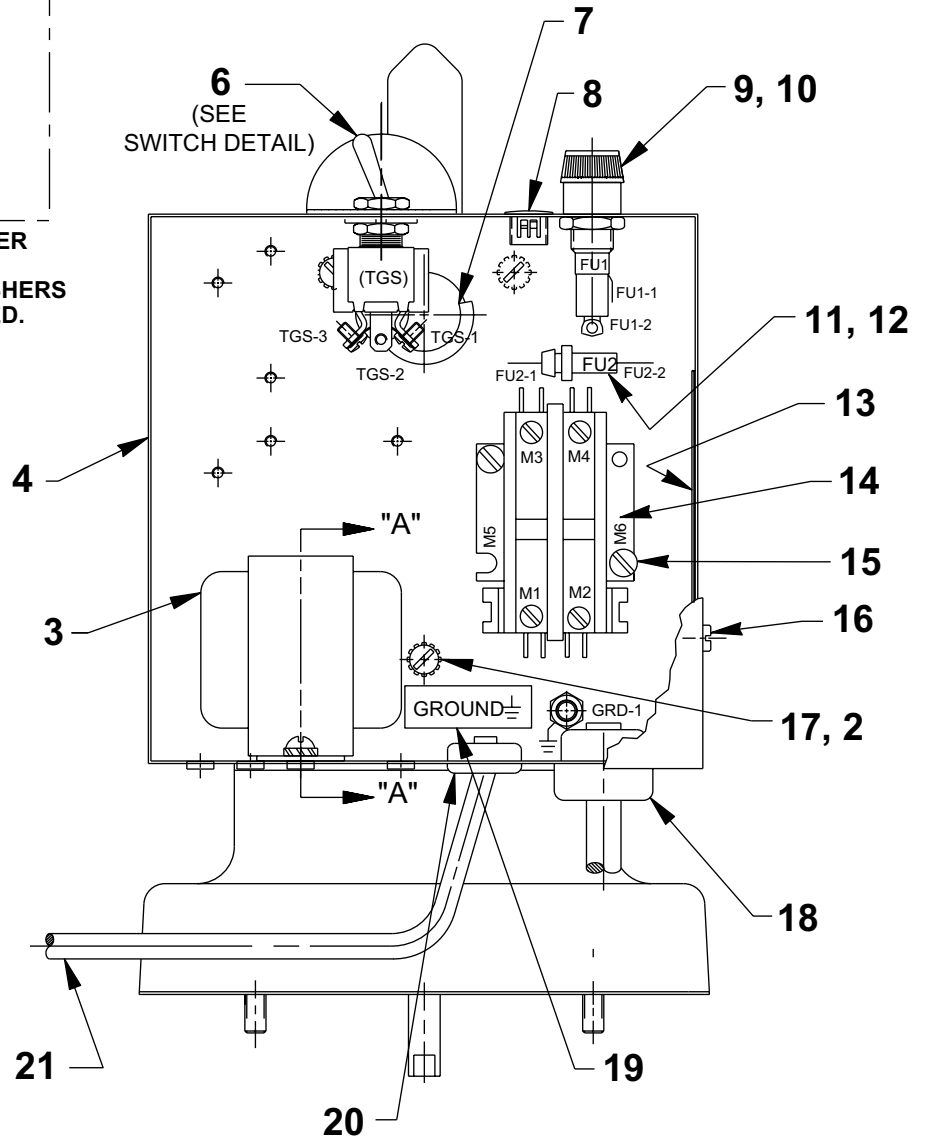

Parts List Continued

ITEM	PART NO.	DESCRIPTION	QTY.
1	11539	SCREW (10-24 X 1/4 LG.)	1
2	11108	EXTERNAL TOOTH WASHER (.40 X .20)	6
3	11852	TRANSFORMER	1
4	65264WH2	ELECTRICAL CONTROL BOX	1
6	12665	TOGGLE SWITCH	1
7	15497	RUBBER GROMMET	1
8	17782	SNAP PLUG	1
9	18292	FUSE HOLDER	1
10	252289	FUSE (25 AMP 125 V.)	1
11	16887	FUSE HOLDER	1
12	206962	FUSE (3 AMP 250 V.)	1
13	250150	WARNING DECAL	1
14	420718-4	CONTACTOR (2 POLE)	1
15	10166	SCREW (10-24 X 1/2 LG.)	3
16	14812	SCREW (8-18 X 3/8 LG.)	4
17	10164	SCREW (10-24 X 3/8 LG.)	3
18	210112	STRAIN RELIEF BUSHING	1
19	205189	DECAL (GROUND)	1
20	15993	STRAIN RELIEF BUSHING	1
21	203225	HAND SWITCH ASSEMBLY (HEAVY DUTY RUBBER; NOT SHOWN)	1
22	11856	SCREW (10-24 X 1" LG.)	1
23	10197	HEX NUT (10-24)	3

ELECTRICAL SCHEMATIC 115V., 60 HZ.

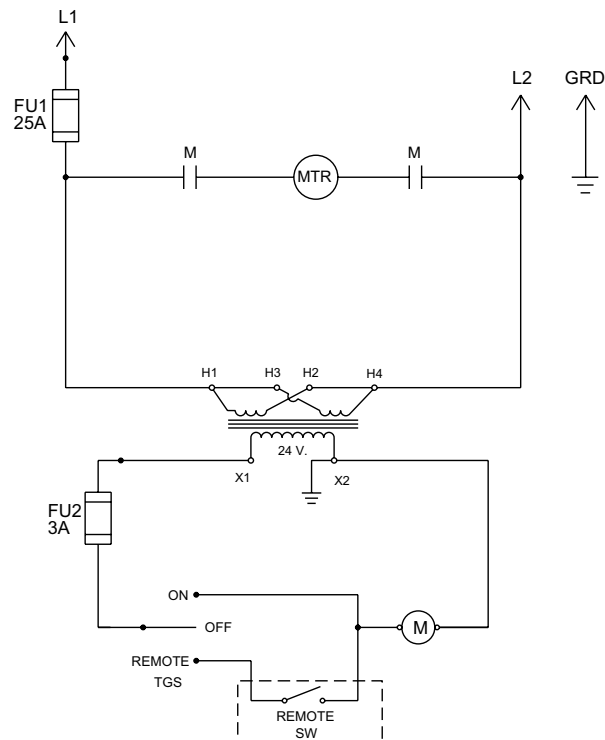

Parts List Continued

MOTOR ASSEMBLY- 4-WAY SOLENOID VALVES
 (FOR PE554S, PE554S-C, PE554S-BOLT & AHC-10E)

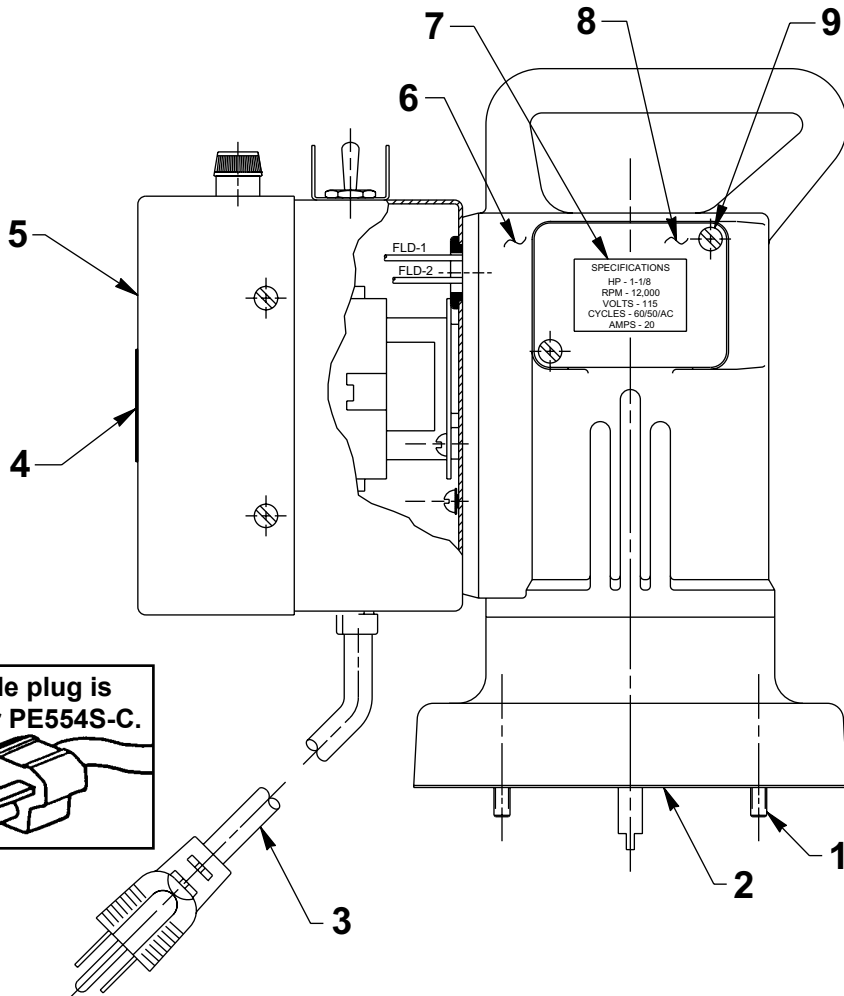
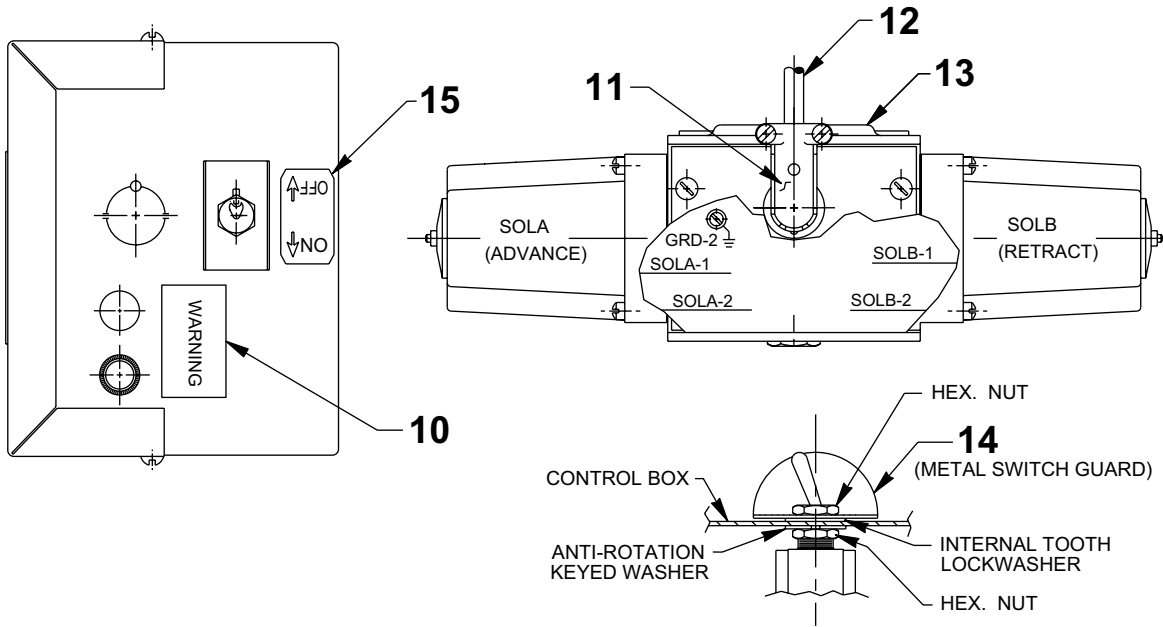

Parts List Continued

ITEM	PART NO.	DESCRIPTION	QTY.
1	10022	SCREW (1/4-20 X 1-1/2 LG.)	4
2	30650	MOTOR BASE GASKET	1
3	307440	CORD (8 FT. LG.; 115 V. 12/3 SJTO; FOR PE554S)	1
	350155	CORD (8 FT. LG.; 115 V. 12/3 SJTO; FOR PE554S-C)	1
4	200188	DECAL (WARNING/IMPORTANT)	1
5	43126WH2	CONTROL BOX COVER	1
6	53338	UNIVERSAL MOTOR ASSEMBLY (110/115 V. 50/60 HZ.; SEE PAGE 2)	1
7	215164	SPECIFICATIONS DECAL	1
8	21008	COVER	2
9	11539	SCREW (10-24 X 1/4 LG.)	4
10	252305	WARNING DECAL	1
11	11144	90° ELBOW CONNECTOR	1
12	66205-115	SOLENOID VALVE	1
13	15565	CABLE (16/4 SO)	2.5 ft.
14	352061	SWITCH GUARD	1
15	360069	DECAL (REMOTE/OFF, FOR AHC-10E)	1
	205409	DECAL (ON/OFF; FOR PE554S, PE554S-BOLT, & PE554S-C)	1

Parts List Continued

ELECTRICAL SCHEMATIC - 4-WAY SOLENOID VALVES
115 V., 60 Hz.

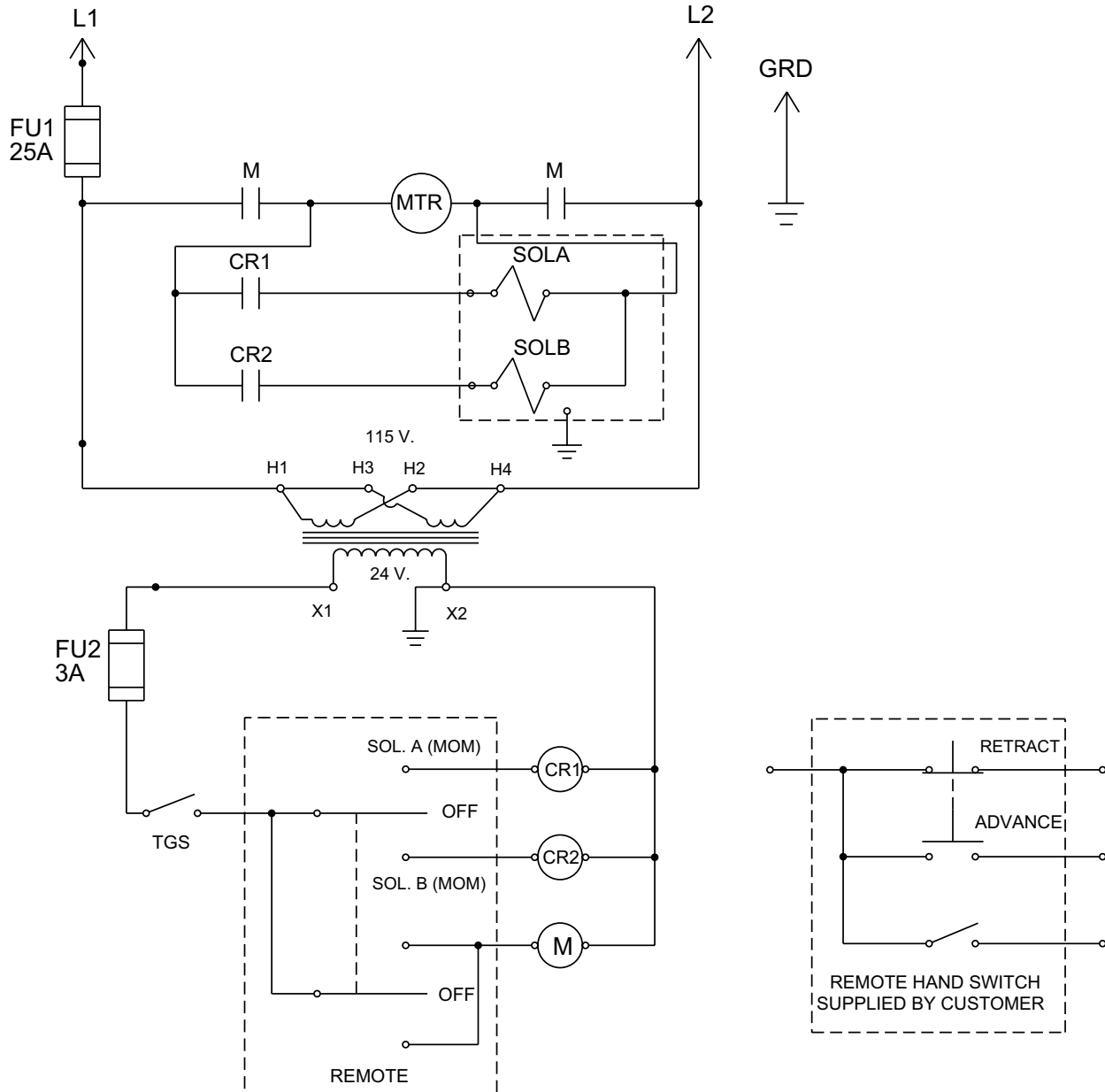

⚠ WARNING : To help avoid personal injury, all electrical work must be done by a qualified electrician.

North American and International Color Codes

Conductors	North American	International
Line	Black	Brown
Neutral	White	Blue
Ground.....	Green.....	Green/Yellow

MOTOR CONTROL BOX - 4-WAY SOLENOID VALVES

(FOR PE554S, PE554S-C, PE554S-BOLT & AHC-10E)

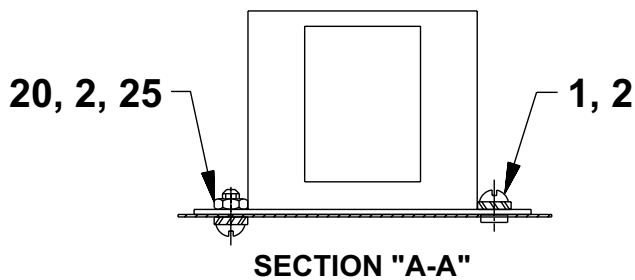
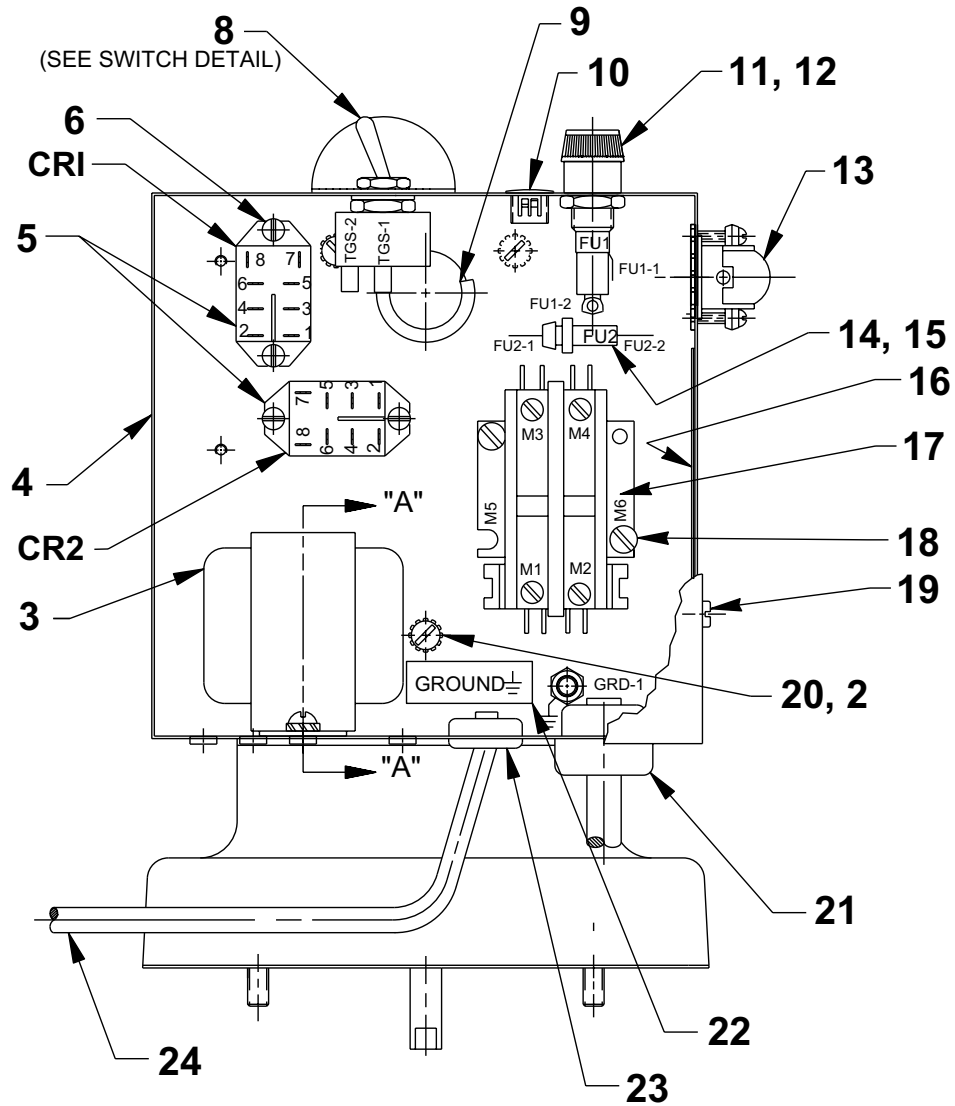

POWER CORD GROUND
(MUST BE ISOLATED BETWEEN
NUTS AND CAN BE AT
TOP OR BOTTOM OF STACK.)

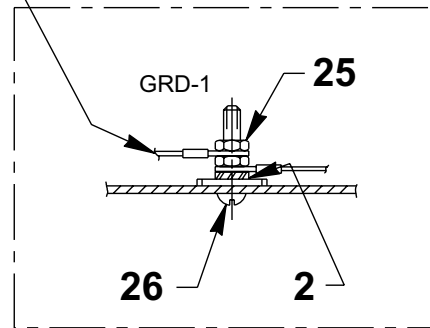

NOTE: SERRATED LOCK WASHER
MUST BE ADJACENT TO
METAL BOX. MORE WASHERS
CAN BE USED IF DESIRED.

Parts List Continued

ITEM	PART NO.	DESCRIPTION	QTY.
1	11539	SCREW (10-24 X 1/4 LG.; FOR PE554S, PE554S-C & AHC-10E)	1
	11539	SCREW (10-24 X 1/4 LG.; FOR PE554S-BOLT)	2
2	11108	EXTERNAL TOOTH WASHER (.40 X .20; FOR PE554S,"PE554S-C & AHC-10E)	6
	11108	EXTERNAL TOOTH WASHER (.40 X .20; FOR PE554S-BOLT)"	5
3	11852	TRANSFORMER	1
4	65264WH2	ELECTRICAL CONTROL BOX	1
5	251046	GENERAL PURPOSE RELAY (FOR PE554S, PE554S-C & AHC-10E)	2
	251046	GENERAL PURPOSE RELAY (FOR PE554S-BOLT)	1
6	17563	SCREW (6-32 X 1/4 LG.)	4
8	12301	TOGGLE SWITCH	1
9	15497	RUBBER GROMMET	1
10	17782	SNAP PLUG	1
11	18292	FUSE HOLDER	1
12	252289	FUSE (25 AMP 125 V.)	1
13	11144	90° ELBOW CONNECTOR	1
14	16887	FUSE HOLDER	1
15	206962	FUSE (3 AMP 250 V.)	1
16	250150	WARNING DECAL	1
17	420718-4	CONTACTOR (2 POLE)	1
18	11539	SCREW (10-24 X 1/4 LG.)	2
19	14812	SCREW (8-18 X 3/8 LG.)	4
20	10164	SCREW (10-24 X 3/8 LG.; FOR PE554S & PE554S-C)	3
21	210112	STRAIN RELIEF BUSHING	1
22	205189	DECAL (GROUND)	1
23	15993	STRAIN RELIEF BUSHING	1
24	304718	HAND SWITCH ASSEMBLY (NOT PART OF AHC-10E; SEE PARTS LIST NO. 101644)	1
25	10197	HEX NUT (10-24; FOR PE554S & PE554S-C)	3
26	11856	SCREW (10-24 X 1" LG.)	1

GENERAL PUMP ASSEMBLY

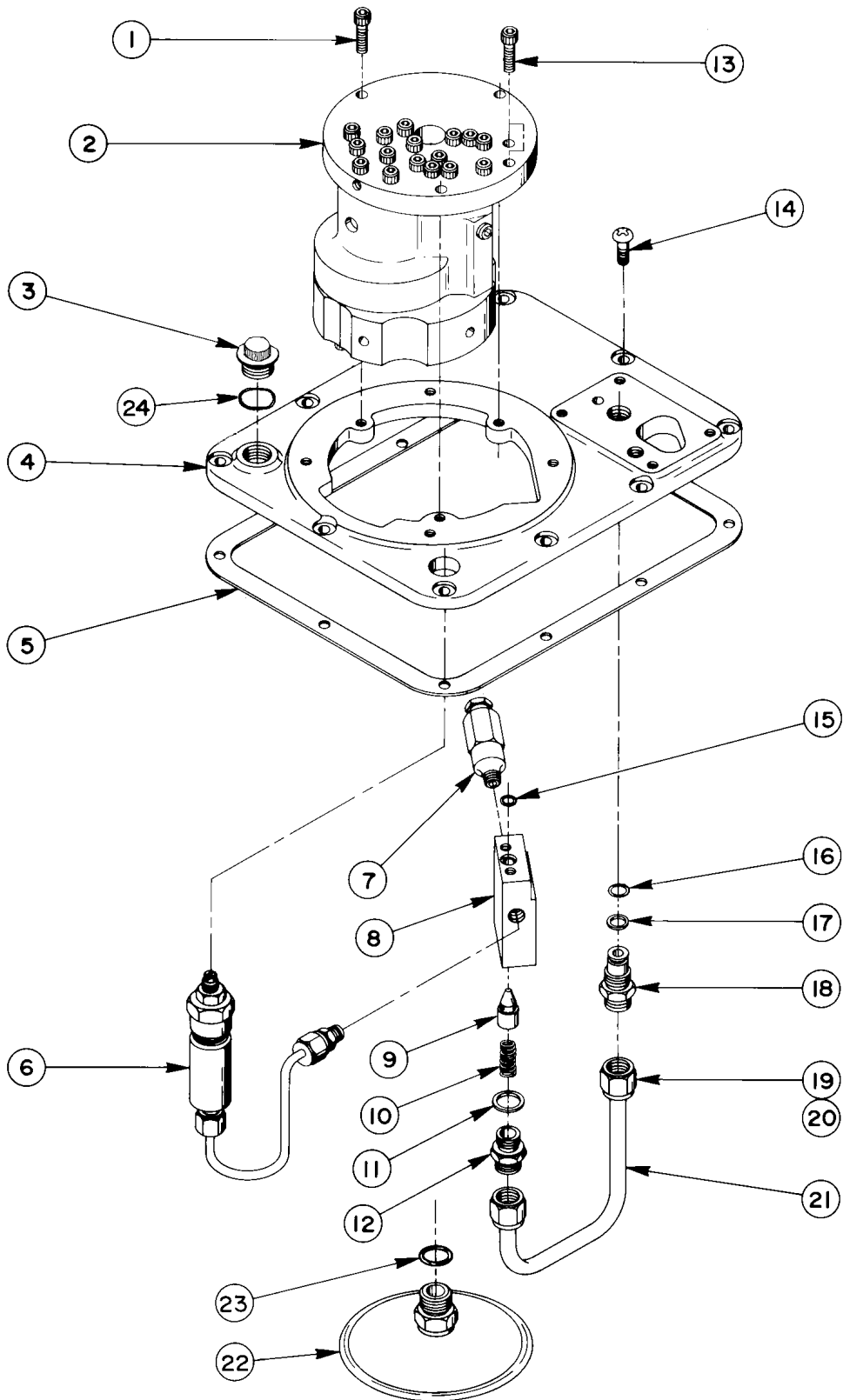

Parts List Continued

ITEM	PART NO.	DESCRIPTION	QTY.
1	10016	SOC. HD. CAP SCREW (1/4-20 UNC X 1" LG.)	3
2	*27207	BASIC PUMP ASS'Y REPLACEMENT	1
3	251689	FILLER PLUG (FOR ALL EXCEPT AHC-10E)	1
	20937	FILLER PLUG (FOR AHC-10E)	1
4	40064WH2	COVER	1
	64856BK2	COVER (FOR 60014 & 60018)	1
5	40164	GASKET	1
6	22360	PRESSURE REGULATOR ASS'Y (SEE NEXT PAGE)	1
	47647	PRESSURE REGULATOR ASS'Y (FOR AHC-10E; SEE FORM NO. 102581)	1
7	21278	RELIEF VALVE (SET AT 10,100/10,700 PSI)	1
	21278-50	RELIEF VALVE (SET AT 5,100/5,700 PSI)	1
	207975-105	RELIEF VALVE (SET AT 10,000/10,500 PSI; FOR PE554C & E554C-C)	1
8	20776	VALVE BODY	1
9	20771	POPPET	1
10	10425	COMPRESSION SPRING (3/8 O.D. X3/4 LG.)	1
11	10261	COPPER WASHER (3/4 X 19/32 X 1/32)	1
12	20770	CONNECTOR (TORQUE TO 40/50 FT. LBS.)	1
13	10015	SOC. HD. CAP SCREW (1/4-28 UNF X 1" LG.; TORQUE TO 130/180 IN. LBS.)	2
14	10177	MACH. SCREW	10
15	10266	O-RING (3/8 X 1/4 X 1/16)	1
16	10268	O-RING (1/2 X 3/8 X 1/16)	1
17	11863	TEFLON BACKUP WASHER	1
18	20787	VALVE CONNECTOR	1
19	10430	TUBE SLEEVE	2
20	10431	TUBE NUT	2
21	21045	OIL LINE	1
22	21344	FILTER ASS'Y (INCLUDES ITEM 23)	1
23	10300	O-RING (5/8 X 15/32 X 5/62)	1
24	200415	O-RING (13/16 X 5/8 X 3/32)	1

*Includes all items on page 26 and items 1, 7, 8, 9, 10, 11, 12, 13, 15 & 22 on this page.

Parts List Continued

PRESSURE REGULATOR ASSEMBLY

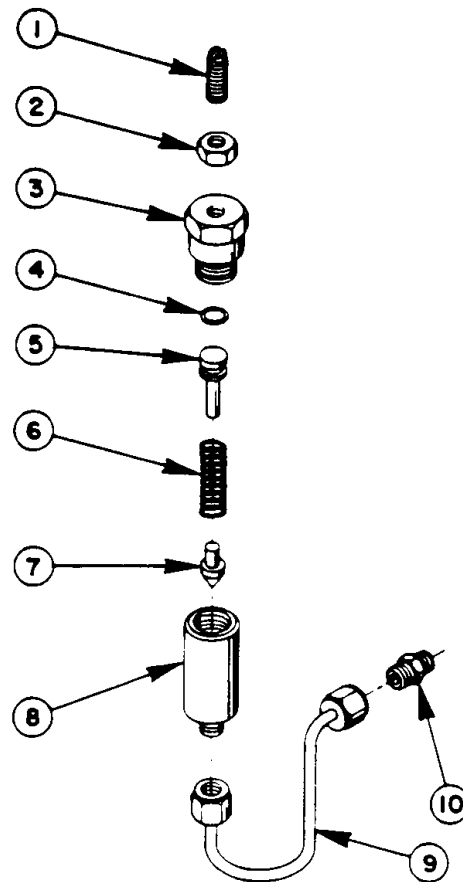

ITEM	PART NO.	DESCRIPTION	QTY.
1	22362	ADJUSTING SCREW	1
2	10386	HEX JAM NUT	1
3	21305	VALVE CAP	1
4	10268	O-RING (1/2 X 3/8 X 1/16)	1
5	21306	SPRING GUIDE	1
6	10495	COMPRESSION SPRING (1/2 O.D. X 1-5/8 LG.)	1
7	21046	VALVE STEM	1
8	22361	BODY	1
9	29267	OIL LINE ASS'Y (WITH NUTS)	1
10	14844	CONNECTOR FITTING	1

BASIC PUMP ASSEMBLY

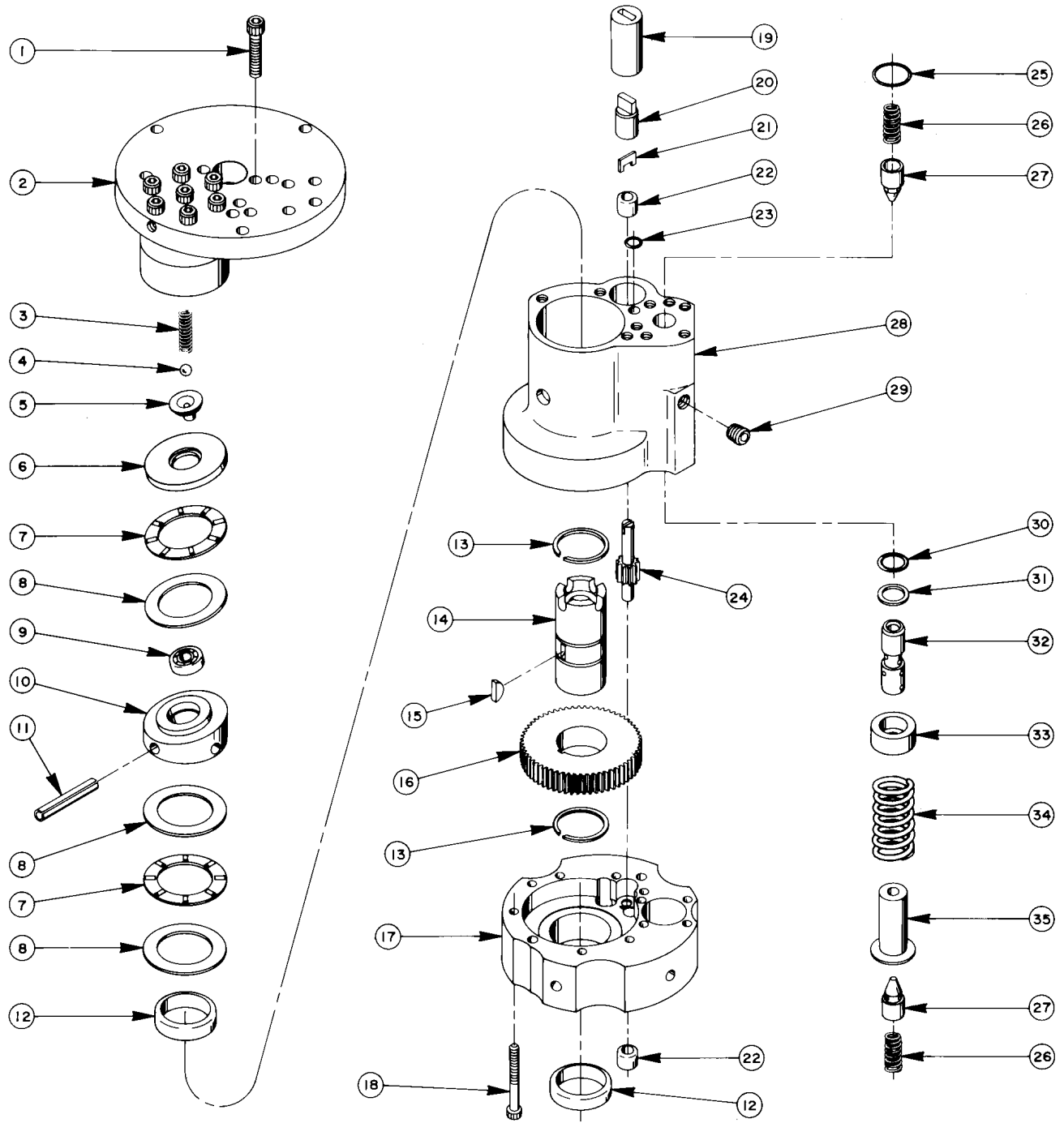

Parts List Continued

ITEM	PART NO.	DESCRIPTION	QTY.
1	10020	SOC. HD. CAP SCREW (1/4-20 UNC X 1-1/4 LG.: TORQUE TO 170-180 IN. LBS.)	9
2	33113	HIGH PRESSURE PUMP ASS'Y (SEE NEXT PAGE)	1
3	10361	COMPRESSION SPRING (1/4 O.D. X 1" LG.)	1
4	10375	STEEL BALL (1/4" DIA.)	1
5	23547	BEARING TOP PLATE	1
6	23548	TOP PLATE	1
7	11228	THRUST BEARING	2
8	11813	BEARING RACE	3
9	11814	BALL BEARING	1
10	23549	ANGLE PLATE	1
11	11955	ROLL PIN (1/4" DIA. X 1-3/4 LG.)	1
12	11064	NEEDLE BEARING	2
13	11261	RETAINING RING	2
14	23556	SHAFT	1
15	11821	WOODRUFF KEY	1
16	23574	GEAR	1
17	40072	PUMP END PLATE	1
18	10001	SOC. HD. CAP SCREW (#10-32 UNF X 1-3/4" LG.; TORQUE TO 50 IN. LBS.)	13
19	21091	COUPLING	1
20	21092	ADAPTER	1
21	21093	KEY	1
22	11198	NEEDLE THRUST BEARING (SEE NEXT PAGE)	2
23	10266	O-RING (3/8 X 1/4 X 1/16)	1
24	20774	DRIVE GEAR	1
25	10303	O-RING (7/8 X 3/4 X 1/16)	1
26	10425	COMPRESSION SPRING (3/8 O.D. X 3/4 LG.)	2
27	20771	POPPET	2
28	40071	PUMP BODY	1
29	10427	PIPE PLUG (1/8" NPTF)	1
30	10271	O-RING (11/16 X 1/2 X 3/32)	1
31	12389	TEFLON BACKUP WASHER (11/16 X 1/2 X 1/16)	1
32	20849	SPOOL	1
33	23255	SPRING GUIDE	1
34	10426	COMPRESSION SPRING (1" O.D. X 1-13/16 LG.)	1
35	23256	SPRING GUIDE	1

NEEDLE BEARING INSTALLATION SPECIFICATIONS

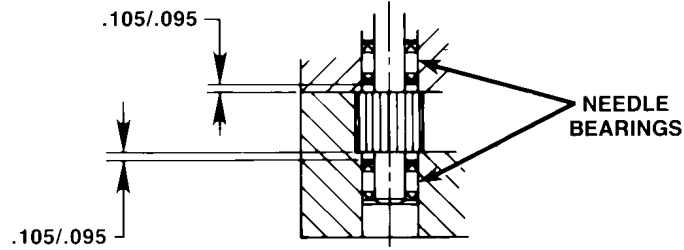

When replacing the needle bearings on the drive gear of the basic pumps, the dimensions shown must be as specified.

HIGH PRESSURE PUMP ASSEMBLY

SEE DIAGRAM ON NEXT PAGE FOR IMPORTANT ASSEMBLY INFORMATION.

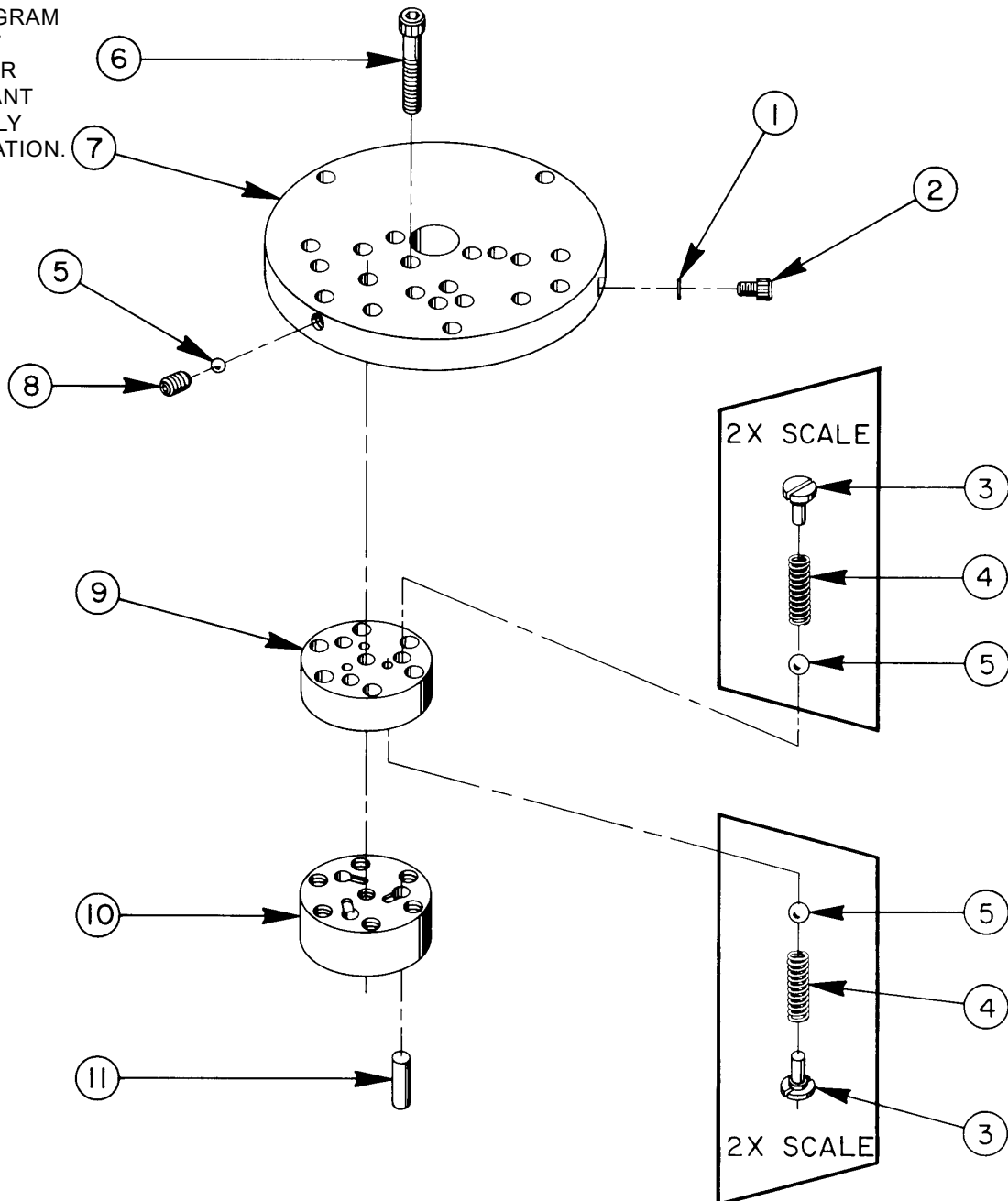

Parts List Continued

33113 PUMP ASSEMBLY 3 Pistons -- 9/32 Dia.

ITEM	PART NO.	DESCRIPTION	QTY.
1	10442	COPPER WASHER (3/8 X 1/4 X 1/32)	1
2	10002	SOC. HD. CAP SCREW (1/4-20 UNC X 3/8" LG.; TORQUE TO 140/160 IN. LBS.)	1
3	24549	VALVE GUIDE	6
4	10445	COMPRESSION SPRING (5/32" O.D. X 3/4" LG.)	6
5	12223	STEEL BALL	7
6	10023	SOC. HD. CAP SCREW (1/4-20 UNF X 1-1/2" LG.; TORQUE TO 170/180 IN. LBS.; SEE NOTE BELOW)	7
7	50411	TOP PLATE	1
8	10519	SOC. SET SCREW (1/4-20 UNC X 3/8 LG.; TORQUE TO 65/70 IN. LBS.)	1
9	40630	VALVE HEAD	1
10	41062	PUMP BARREL	1
11	21628	PISTON	3

BOLT TIGHTENING SEQUENCE

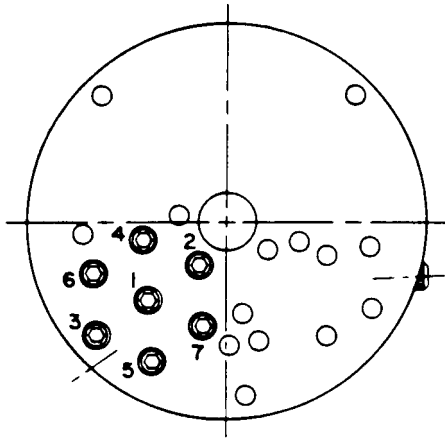

**NOTE: Assemble in sequence shown.
Lubricate under head and on
threads. Torque to 180 in. lbs.**

RESERVOIR ASSEMBLIES

2 GAL. RESERVOIR

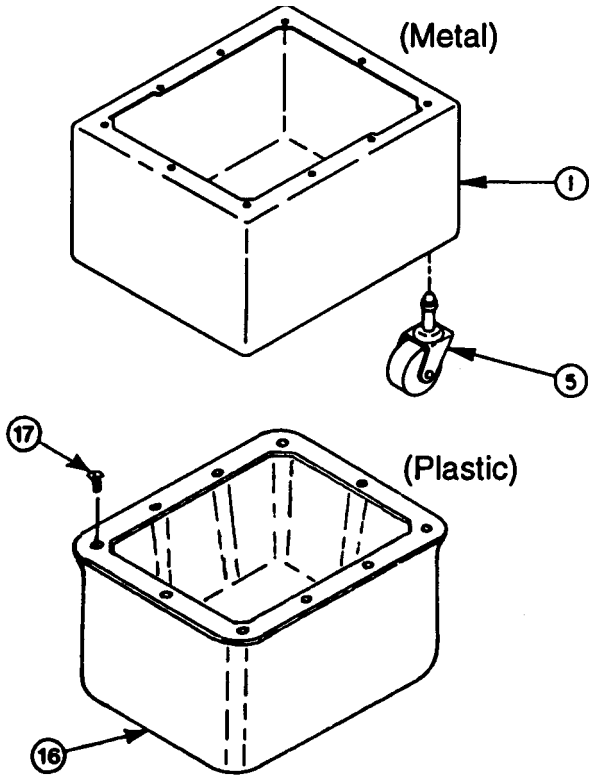

5 & 10 GAL. RESERVOIRS

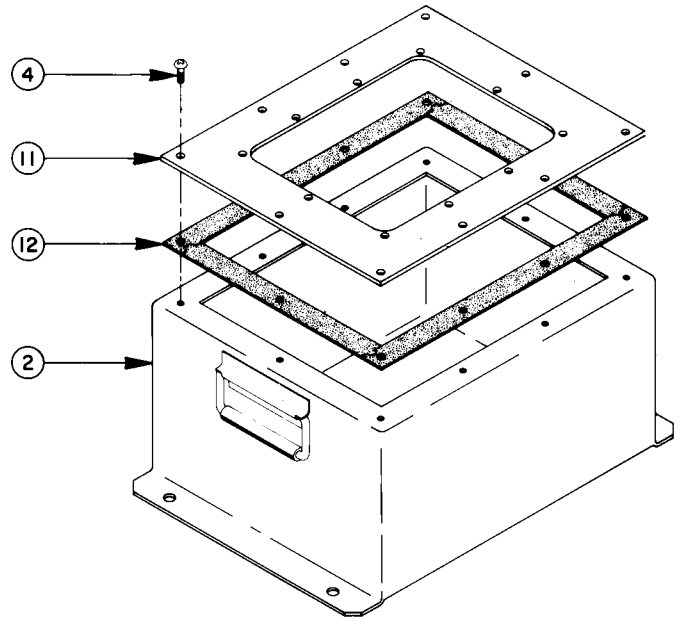

FILTER & EXTENSIONS

Used on 5, 7 & 10 Gal. Reservoirs as Applicable

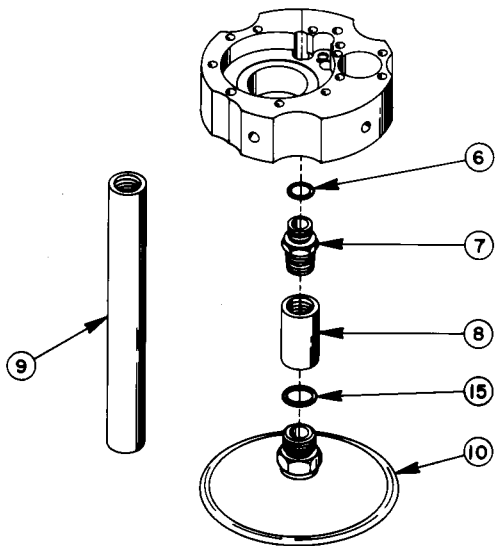

7 GAL. RESERVOIR

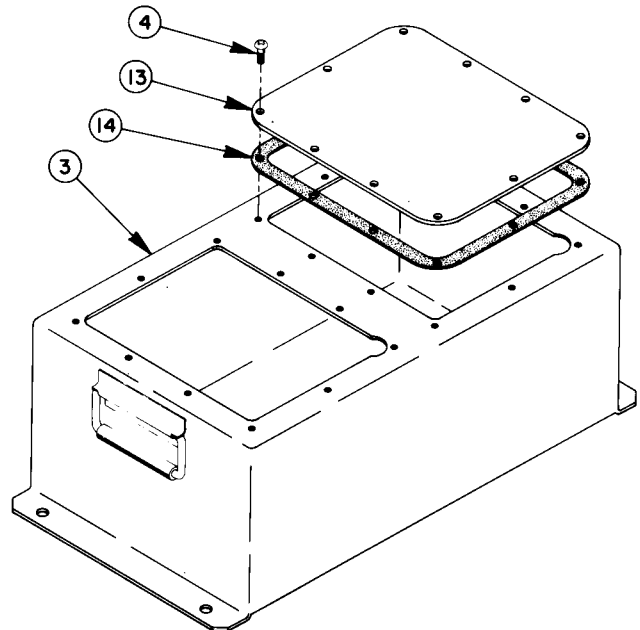

Parts List Continued

RESERVOIR ASSEMBLIES

NOTE: FOR complete Reservoir Assembly order the following:

209122 - Power Team complete 5 Gal. Reservoir Assembly

209123 - Power Team complete 7 Gal. Reservoir Assembly

RP100 - Power Team complete 10 Gal. Reservoir Assembly

These no's. Include the following parts listed below as applicable.

ITEM	PART NO.	DESCRIPTION	QTY.
1	40063OR9	2 GAL. RESERVOIR	1
	60597OR9	2 GAL. RESERVOIR WITH HANDLES & DRAIN	1
	61799OR9	2 GAL. RESERVOIR WITH DRAIN PLUG	1
	66505OR9	2 GAL. RESERVOIR (ALUMINUM; FOR PE554S-BOLT)	1
	64364BK2	2 GAL. RESERVOIR (FOR AHC-10C)	1
2	40137OR9	5 GAL. RESERVOIR	1
	40193OR9	10 GAL. RESERVOIR	1
3	50051OR9	7 GAL. RESERVOIR	1
4	10177	MACHINE SCREW (1/4-20 UNC X 3/4 LG.)	10
5	10494	SWIVEL CASTER (FOR 2 GAL. RES.)	4
6	10300	O-RING (5/8 X 15/32 X 5/64)	1
7	20879	CONNECTOR	1
8	22032	SUCTION LINE (FOR 5 & 7 GAL. RES.)	1
9	22038	SUCTION LINE (FOR 10 GAL. RES)	1
10	21345	FILTER ASSEMBLY	1
11	40194AL2	ADAPTER COVER PLATE (FOR 5 & 10 GAL. RES.)	1
12	40490	GASKET (FOR 5 & 10 GAL. RES.)	1
13	40188AL2	COVER PLATE (FOR 7 GAL. RES.)	1
14	40164	GASKET (FOR 7 GAL. RES.)	1
15	10527	O-RING (13/16 X .644 X .087)	1
16	61165	2 GAL. PLASTIC RESERVOIR	1
17	209799	SELF-TAPPING SCREW (1/4-10 X 7/8 LG.)	10
PARTS NOT SHOWN			
	309219	TRADE NAME DECAL	2
	17586	SIGHT GAUGE (FOR PE554S-BOLT)	1
	350431	SIGHT GAUGE (FOR AHC-10E)	1

Refer to any operating instructions included with this product for detailed information about operation, testing, disassembly, reassembly, and preventive maintenance.

Items found in this parts list have been carefully tested and selected. **Therefore: Use only genuine Power Team replacement parts!**

Additional questions can be directed to our Technical Services Department.

REMOTE HAND SWITCH ASSEMBLY

No. 307491

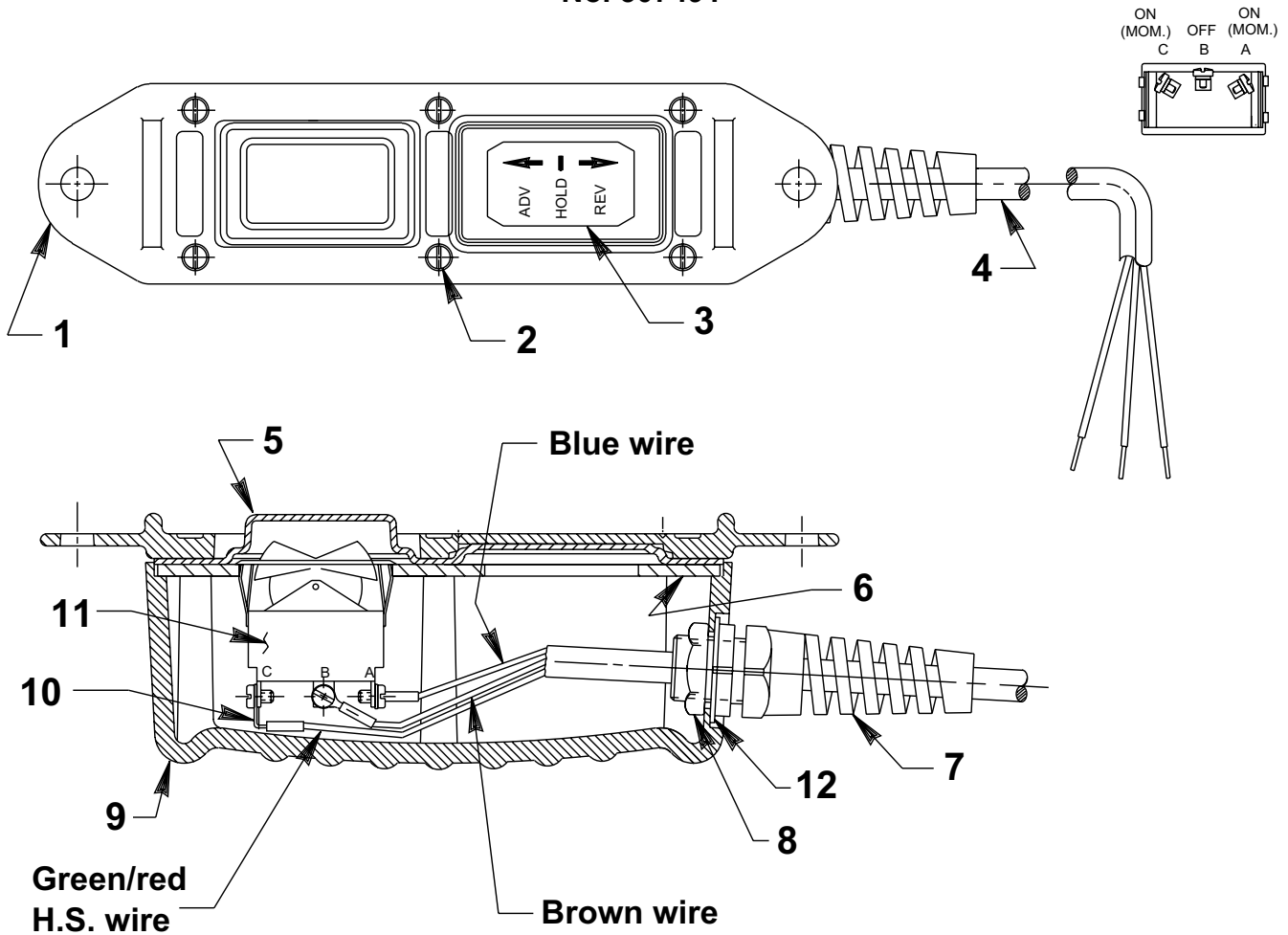

ITEM	PART NO.	DESCRIPTION	QTY.
1	420050-1	COVER	1
2	250248	SCREW (4-24 X 3/4 LG.)	6
3	202776	DECAL	1
4	12293	CABLE (16/3 SJTO)	25 ft.
5	420050-2	GASKET	1
6	420050-3	SWITCH MOUNTING PLATE	1
7	251818	STRAIN RELIEF CONNECTOR	1
8	251802	LOCKNUT (3/4-16 UNF; TORQUE TO 30/35 IN. LBS.)	1
9	420050-4	SWITCH HOUSING	1
10	12311	RING TONGUE TERMINAL	3
11	16773	ROCKER SWITCH	1
12	253607	GASKET	1