

Electrical Safety in General Industry

§1910 Subpart S

Awareness Training for QEW and Unqualified Workers



NC Central
UNIVERSITY

Environmental Health and Safety

Training Objectives

- Understand qualified vs. unqualified electrical workers
- Be familiar with general requirements of the Standard
- Identify common electrical hazards
- Understand definition of Electrically Safe Work Conditions
- Recognize electrical equipment defects/hazards
- Understand basic wiring design and protection
- Identify wiring methods, components, and equipment for general use

Regulations

- [1910 Subpart S - Electrical](#)
- [1910 Subpart R](#)
 - .264 Laundry Machinery and Operations
 - .268 Telecommunications
- [1910.137 - Electrical Protective Equipment](#)
- NFPA 70, 70E, 70B
- NC State Building Code – Fire Code, Section 605

- NCCU Electrical Safety Plan

Qualified Electrical Worker (QEW)

- Person authorized to install, fabricate, repair, test, calibrate, or modify electrical or electronics wiring, devices, systems, or equipment at NCCU
- NFPA 70E
 - ...”one who has demonstrated skill and knowledge related to the construction and operation of electrical equipment and installations and has received safety training to identify and avoid the hazards involved”
 - must be trained in methods of safe release and special precautionary techniques
 - Must be able to demonstrate the ability to use a test instrument to verify the absence of voltage

Unqualified Workers

- Worker who may near electrical equipment but is not authorized to perform any work for which a QEW is required
- Unqualified persons shall receive general electrical safety training but are NOT authorized to conduct any electrical repairs
 - Report all electrical hazards to their supervisor
 - Do not operate equipment if there is an electrical hazard
 - Remember that even low-voltage electricity can be dangerous
 - Do not use cords or plugs that are missing the 'ground' prong
 - Do not overload electrical receptacles
 - Do NOT enter electrical distribution rooms

Causes of Electrical Accidents



- Most are caused by one or a combination of these 3 factors
 - Unsafe equipment and installation
 - Inadequate maintenance can cause equipment or installations to become unsafe
 - Unsafe work environment
 - Unsafe work practices



NC Central
UNIVERSITY

Environmental Health and Safety

Unsafe Equipment and Installation

- Faulty insulation
- Improper grounding
- Loose connections
- Defective parts
- Ground faults
- Unguarded live parts
- Underrated equipment



NC Central
UNIVERSITY

Environmental Health and Safety

Unsafe Work Environment

- Flammable vapors, liquids, or gases
- Corrosive atmospheres
- Wet and damp locations



Unsafe Work Practices

- Failure to de-energize electric equipment when it is being repaired or inspected
- Use of tools or equipment too close to energized parts
- Overloading circuits

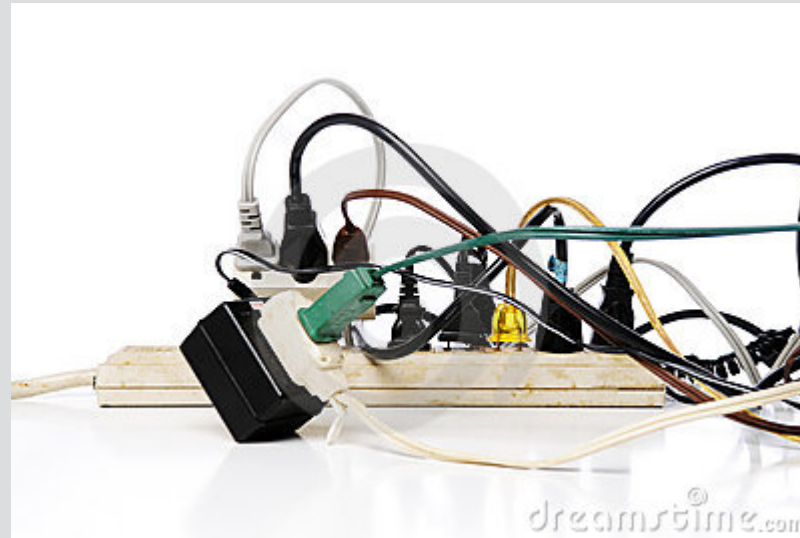

Electrical Safety Model

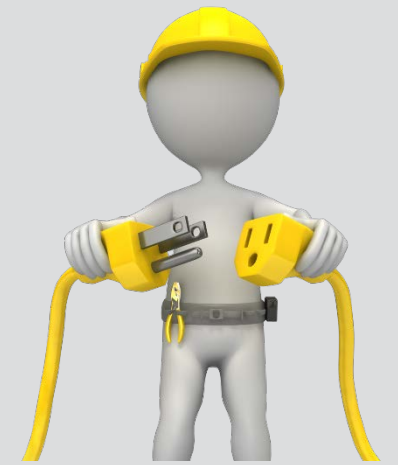

- To make sure you're safe before, during and after electrical work is performed, follow the three-step process of the Electrical Safety Model:
 - **Recognize hazards:** To avoid injury or death, you must first understand and recognize hazards.
 - **Evaluate risk:** You need to evaluate the situation you are in and assess your risks.
 - **Control hazards:** You need to control hazards by creating a safe work environment, by using safe work practices, and by reporting hazards to a supervisor or trainer.



NC Central
UNIVERSITY

Environmental Health and Safety

Recognize Hazards

The most frequent causes of electrical injury/death are:

- Contact with power lines
- Lack of ground-fault protection
- Path to ground missing or discontinuous
- Equipment not used in manner prescribed
- Improper use of extension and flexible cords
- Careful planning of safety procedures reduces the risk of injury
- Decisions to use LOTO on circuits and equipment made during this phase



NC Central
UNIVERSITY

Environmental Health and Safety

Electrical Hazards

- Explosion
 - Electricity provides a source of ignition for an explosive mixture in the atmosphere
- Fire
 - Caused by overloading circuits or excessive current flowing through faulty wiring
- Arc flash
 - Electric current leaves its intended path and travels through the air from one conductor to another, or to ground; often violent in nature



Evaluate Risk

- Not all risk is equal
 - Analyze probability of an injury occurring and the severity of the injury if it occurs
- Identify hazards that could lead to injury or death
- Use current parameters
 - A reasonable place to work on a bright, sunny day might be very hazardous in the rain

Evaluating Risk

	High		Install 7.5 KVA Transformer	
Probability	Medium		Repair 230 VAC Motor	
	Low	Replace 120 VAC Receptacle		
		Low	Medium	High
		Severity		

Taken from OSHATRIN



NC Central
UNIVERSITY

Environmental Health and Safety

Types of Electrical Accidents

- Shock
- Burns
- Fire
- Explosions
- Arc flash
- Falls resulting from electrical injury or incident

Electrical Injury

Table 1. Reaction of the human body to electrical current flows from one of their hands to a foot for 1 second

Effect of AC current (95% of Young Adults Average weight 115-150 lbs)	
Perception Threshold - tingling sensation	0.7-1 mA
Slight Shock (not painful) - no loss of muscle control	1.2-1.8 mA
Shock (painful) - no loss of muscle control	6-9 mA
Shock (severe) - muscle control loss, breathing difficulty, onset of <i>let go</i> threshold	15-23 mA
Possible ventricular fibrillation - 3 send shock	0.1 A
Possible ventricular fibrillation - 1 send shock	0.2 A
Heart muscle activity ceases	0.5 A
Tissue and organ burn	1.5 A

Electrocution

- Electric shock/electrocution occurs when current flows through the body

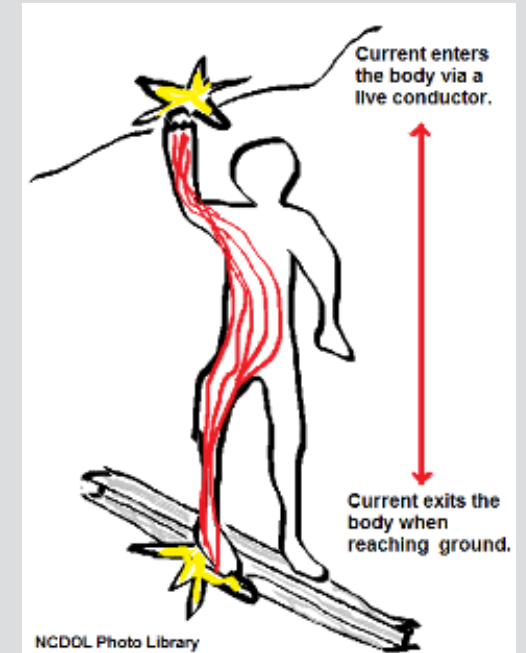

Shock

Current, Not Voltage causes Electric Shock

<u>mA</u>	<u>Affect on Person</u>
0.5 - 3	- Tingling sensations
3 - 10	- Muscle contractions and pain
→ 10 - 40	- “Let-go” threshold
30 - 75	- Respiratory paralysis
→ 100 - 200	- Ventricular fibrillation
200 - 500	- Heart clamps tight
1500 +	- Tissue and Organs start to burn



NC Central
UNIVERSITY

Environmental Health and Safety

Burns

- Thermal contact
 - Skin contact with hot surface of overheated electric conductors, conduits or other energized equipment
- Electrical
 - Electric current flows through tissues
 - Skin deep or affect deeper layers of muscle and bone
- Arc
 - Result from high temperatures produced by electric arcs or by explosions close to body
- All three types may be produced at the same time



NC Central
UNIVERSITY

Environmental Health and Safety

Control Hazards

- Hazards may be controlled or minimized by creating a safe work environment, using safe work practices, and being properly trained
 - **Limit Exposure** - Reduce the amount of time spent around high energy equipment.
 - **Maintain Distance** - Always stay as far away as possible from high-energy equipment unless there is a specific need.
 - **Increase Mass** - Try to keep some type of sturdy material between you and a potential blast.
 - **Wear Proper PPE** – PPE can offer some protection to eyes, face, hands and minimize burns resulting from blasts.

Protections Against Electrical Hazards

- **Insulation** – conductor material to stop or reduce the flow of electrical current to prevent shock, fires, and short circuits
- **Guarding** - Enclose electric equipment to ensure that workers do not come in contact with any exposed electrical parts. Also signage to forbid entry to unauthorized personnel.
- **Grounding** - intentionally creating a low-resistance path that connects to the earth to prevent the buildup of voltages, including a static charge. May be done for tools, equipment or specific part of electrical system. May be permanent part of electrical circuit.
- **Electrical Protective Devices** – Devices that stop the flow of electric current if short circuit occurs including fuses, breakers, and GFCIs

Electrically Safe Work Conditions

- When the conductor or circuit part to be worked on has been **disconnected** from energized parts, **locked/tagged out**, **tested** to ensure the absence of voltage, and **grounded** if necessary
- All four mechanisms must be used together
- When work can not be done under electrically safe work conditions it is known as Energized Work and is poses a greater risk

Energized Work Decision Tree

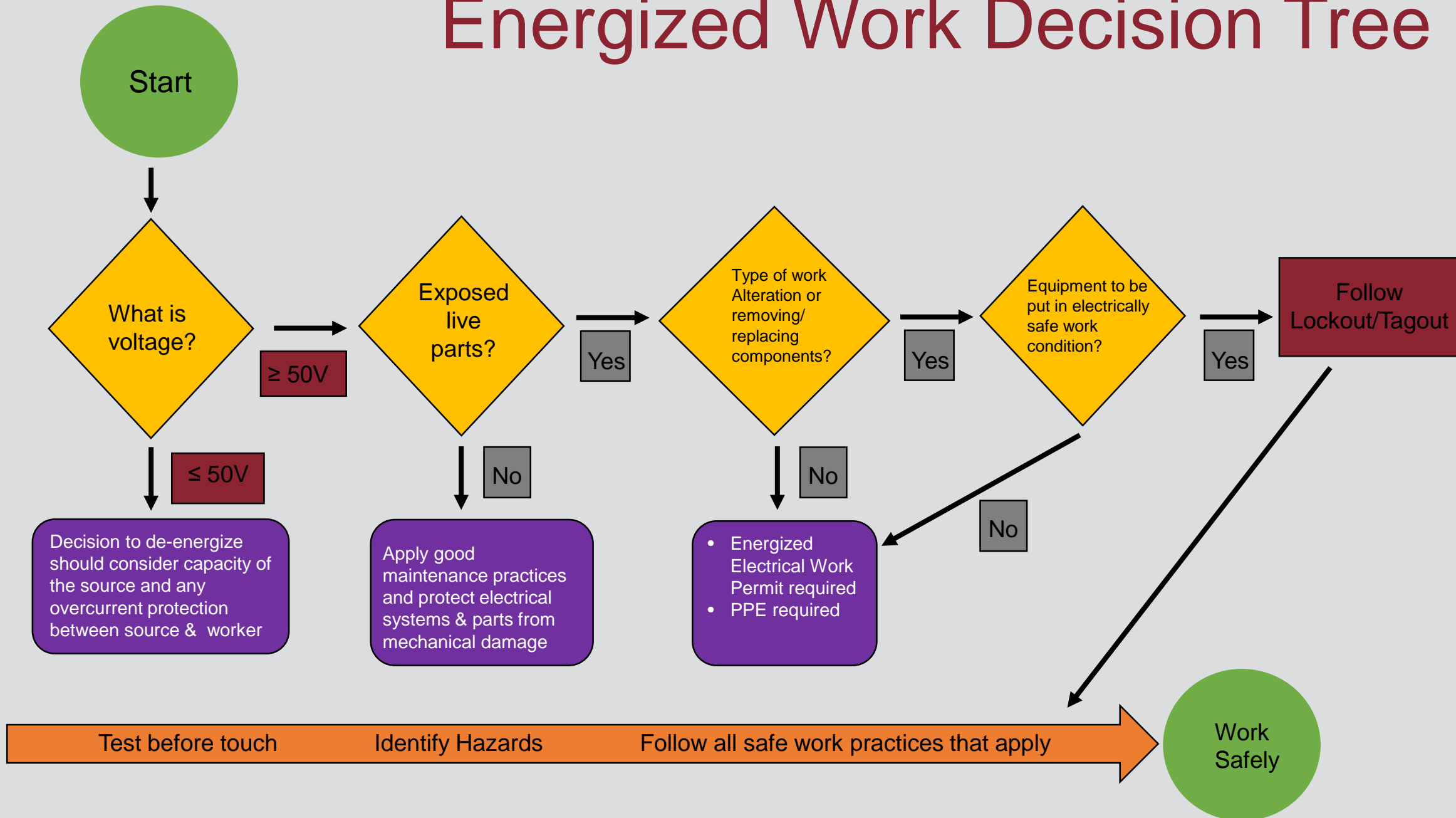

Arc Flash

Electric current leaves its intended path and travels through the air from one conductor to another, or to ground; often violent in nature

Causes

- Dust
- Dropping tools
- Accidental touching
- Condensation
- Material failure
- Corrosion
- Faulty Installation

Factors determine severity

- Proximity of worker
- Temperature
- Time for circuit to break

Risks

- Burns
- Fire
- Flying objects (often molten metal)
- Blast pressure (upwards of 2,000 lbs/sq ft)
- Sound blast (as loud as a gun)
- Heat (upwards of 35,000 °F)



NC Central
UNIVERSITY

Environmental Health and Safety

NFPA Arc Flash Boundaries

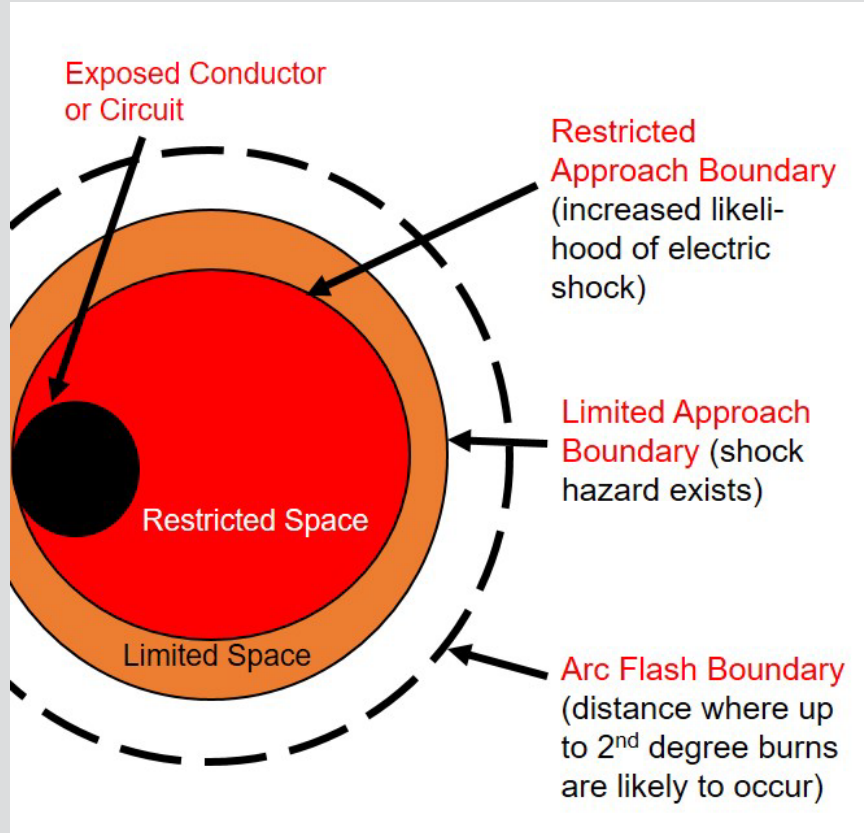

Boundary	Meaning
Arc Flash	<ul style="list-style-type: none"> Outer boundary of the flash protection zone Workers crossing it must wear flash protective equipment
Limited Approach	<ul style="list-style-type: none"> Only QEW allowed to cross without QEW escort Workers must wear flash protective equipment
Restricted Approach	<ul style="list-style-type: none"> Only QEW may cross this boundary at any time Must have approved Energized Electrical Work Permit Must use PPE appropriate for working near energized parts No body part may cross the prohibited line
Prohibited Approach (area nearest exposed conductor or circuit)	<ul style="list-style-type: none"> Crossing this line is the same as having contacting live part Only QEW may cross this line Must have specific training to work on energized parts Must have Energized Electrical Work Permit approved Must wear PPE appropriate for working on live parts

- Designed to protect employees when working on or near energized equipment
- No common distance measurement – distance based on equipment

Arc Flash Analysis

- Process of studying a facility's electrical equipment to determine the incident energy levels at any given part of the electrical system.
 - Determines whether workers who come into contact with certain parts of an electrical system will be safe during an arc flash event
 - Identifies and documents
 - The flash protection boundary
 - Proper personal protective equipment (PPE)
 - Appropriate safety related work practices
- Acceptable methods defined by NFPA 70E
 - **Incident Energy Analysis Method** - most often done by an electrical professional; can be calculated using an [online flash calculator](#)
 - **Arc Flash PPE Category Method** – Uses NFPA tables to determine required PPE if all required information is available and an Incident Energy Analysis has not been completed



NC Central
UNIVERSITY

Environmental Health and Safety

Arc Flash Warning

- Required information required includes the following based on method used

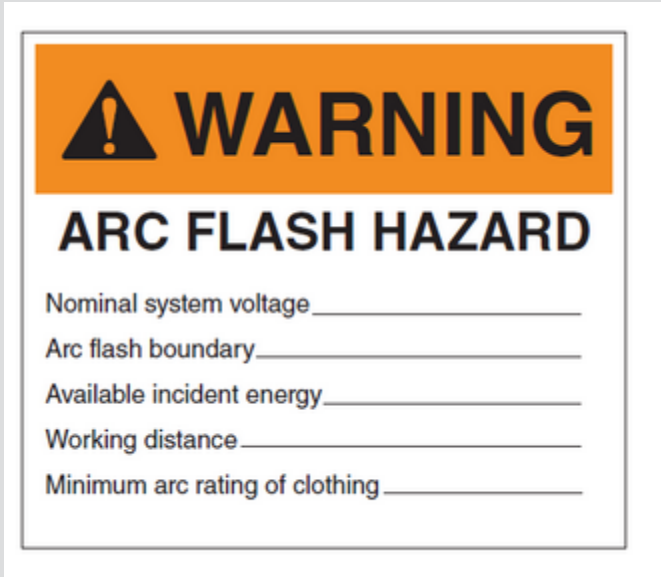

WARNING
ARC FLASH HAZARD

Nominal system voltage _____
Arc flash boundary _____
Available incident energy _____
Working distance _____
Minimum arc rating of clothing _____

Incident Energy Method

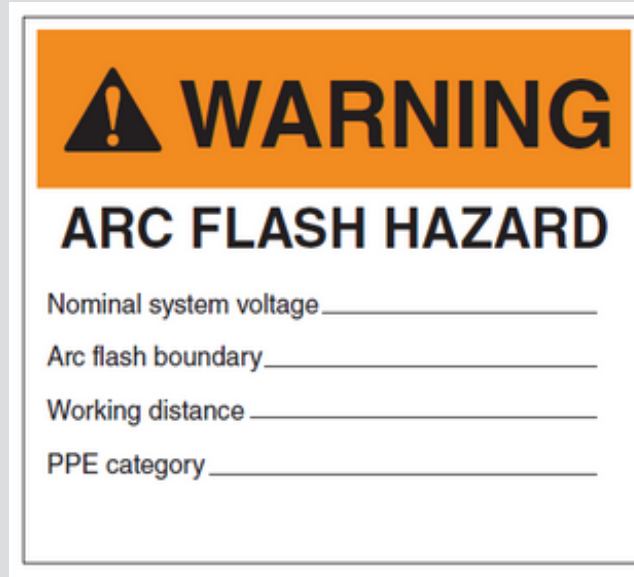

WARNING
ARC FLASH HAZARD

Nominal system voltage _____
Arc flash boundary _____
Working distance _____
PPE category _____

Arc Flash PPE Method

Energized Electrical Work Permit

- Energized work shall be permitted if de-energizing introduces additional hazards or increased risk
- Energized Electrical Work Permit required
 - When work is performed within the restricted approach boundary
 - When the employee interacts with the equipment when conductors or circuit parts are not exposed but an increased likelihood of injury from an exposure to an arc flash hazard exists
- QEW may perform work on energized equipment without a permit using safe work practices and PPE under the following conditions
 - Testing, troubleshooting, or voltage measuring
 - Thermography, ultrasound, or visual inspections if the restricted approach boundary is not crossed
 - Access to and egress from an area with energized electrical equipment if no electrical work is performed and the restricted approach boundary is not crossed
 - General housekeeping and miscellaneous non-electrical tasks if the restricted approach boundary is not crossed



NC Central
UNIVERSITY

Environmental Health and Safety

Electrical Safety Controls and Requirements



NC Central
UNIVERSITY

Environmental Health and Safety

General

- Electrical equipment must be free from recognized hazards
 - Cables exposed to sharp edges
 - Splices
 - Bare conductors
 - Insulation not intact
- Unused openings must be effectively closed to afford protection substantially equivalent to the wall of the equipment



NC Central
UNIVERSITY

Environmental Health and Safety

Labeling Requirements

- A label is required for any piece of electrical equipment that may need examination, adjustment, service or maintenance while energized
 - Must have the manufacturer's name, trademark, or other descriptive marking
 - Must provide voltage, current, wattage, or other ratings as necessary



National Recognized Testing Laboratories -NRTL

- Certifies that certain products meet the requirements of both the construction and general industry OSHA electrical standards
- After certifying a product, the NRTL authorizes the manufacturer to apply a registered certification mark to the product
- A listing of NCDDOI/OSFM approved testing laboratories can be found at <https://www.ncosfm.gov/codes/state-electrical-division/qualified-testing-laboratories>

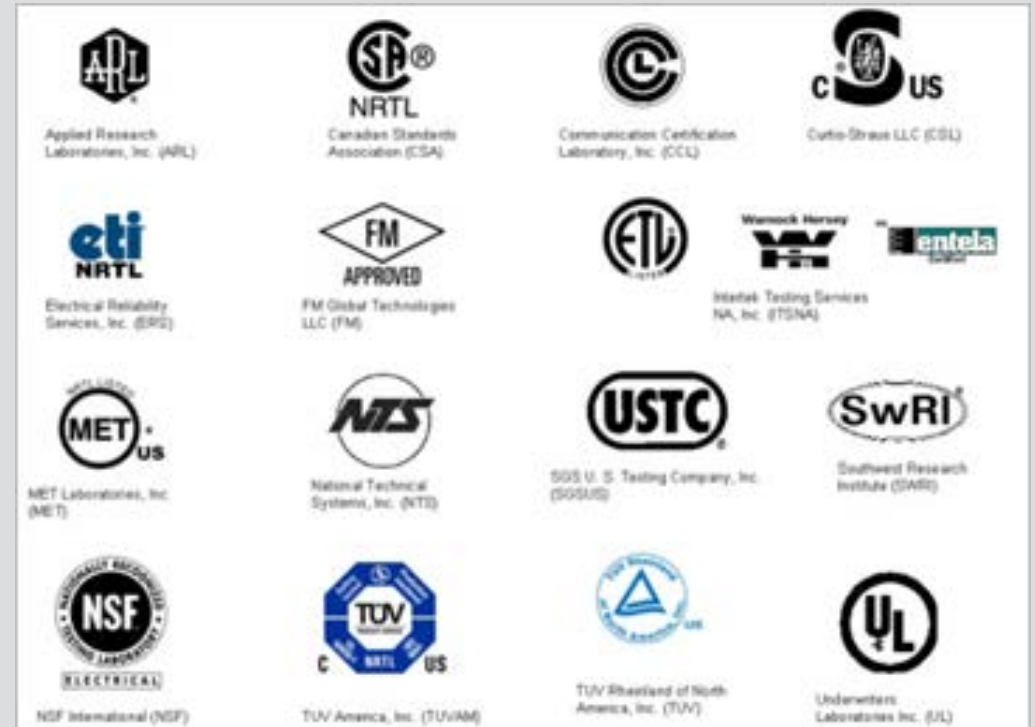

NC Central
UNIVERSITY

Environmental Health and Safety

Electrical Wiring

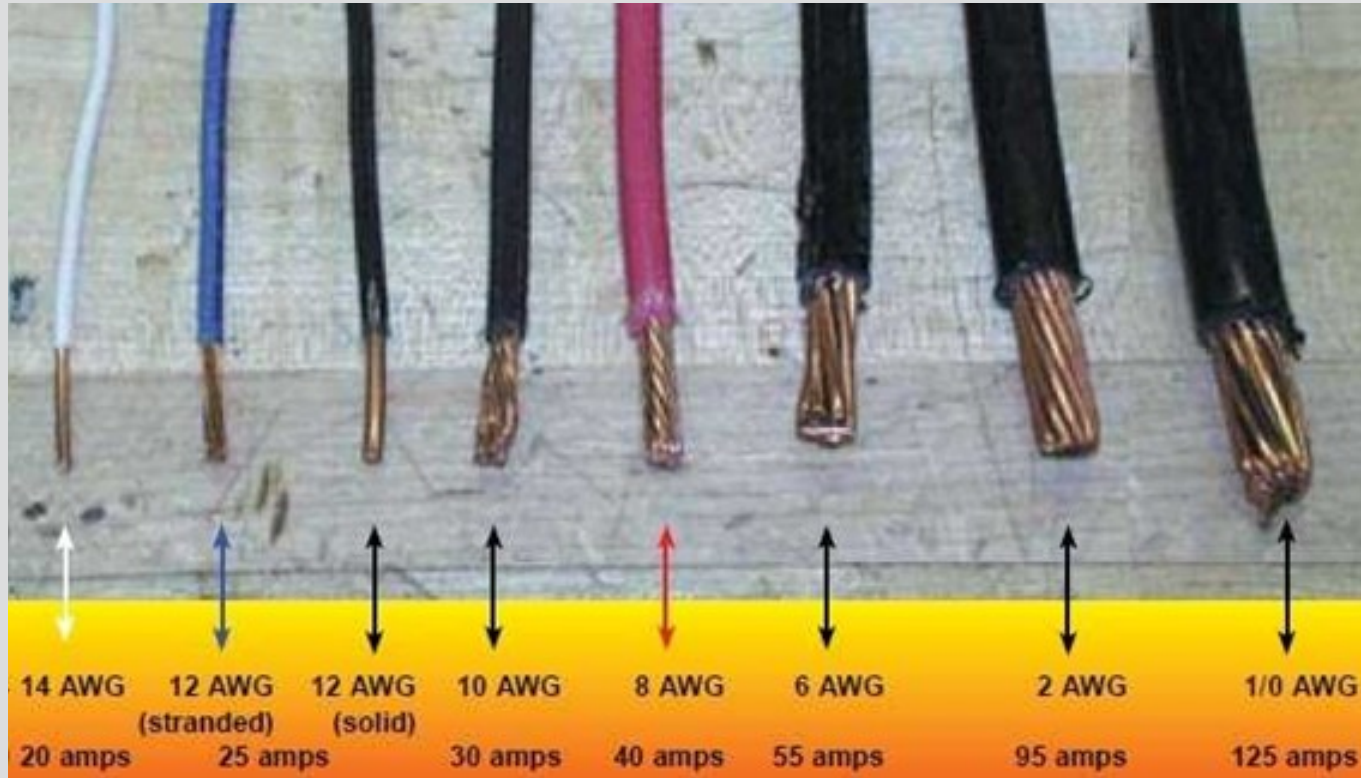

- Larger gauge number indicates smaller size wire
- Use adequately sized wire for job

Splices

- Splicing devices must be used – not tape
- Splices must be joined mechanically and electrically secure before soldering

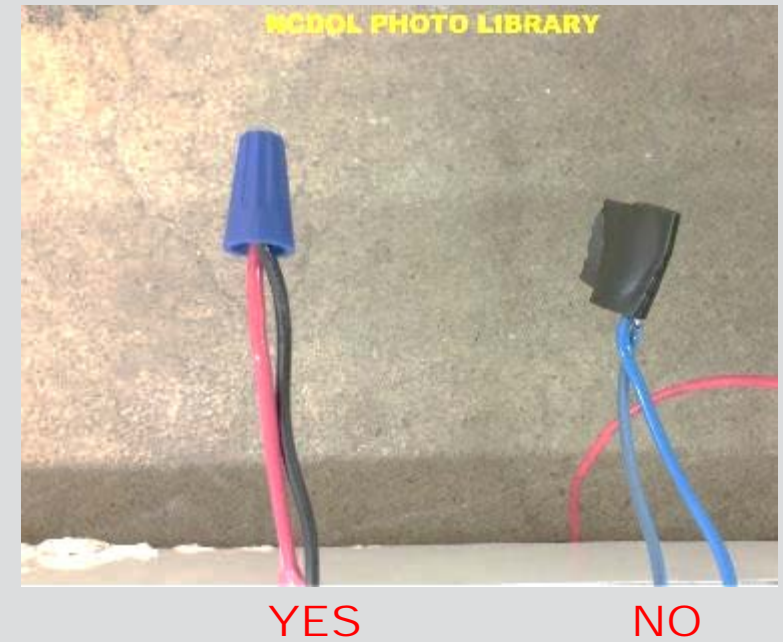

NC Central
UNIVERSITY

Environmental Health and Safety

Grounding

- Conductive connection to the earth which acts as a protective measure
- Protects against
 - Shock
 - Fire
 - Equipment damage
- Path to ground from circuits must be
 - Permanent,
 - Continuous, *and*
 - Effective



NC Central
UNIVERSITY

Environmental Health and Safety

Two Types of Grounding Conductors

- **Electrical Circuit or System Grounding**
 - Energized circuit
 - Connected to earth through system ground
 - Protects circuit from lightning or other high voltage contact
 - Stabilizes voltage in system so expected voltage levels are not exceeded under normal conditions
- **Equipment grounding conductor**
 - Safeguard against insulation failure or faults in other circuit conductors
 - Not energized under normal conditions
 - Directs current back to source so fuses or circuit breakers can operate
 - Metal frames and enclosures of equipment are grounded
 - Hand held tools



NC Central
UNIVERSITY

Environmental Health and Safety

Identification of Grounding Conductors

- Grounding conductors must be identifiable and distinguishable from other
 - Circuit/System – white or gray
 - Equipment – Green, green/yellow striped or bare

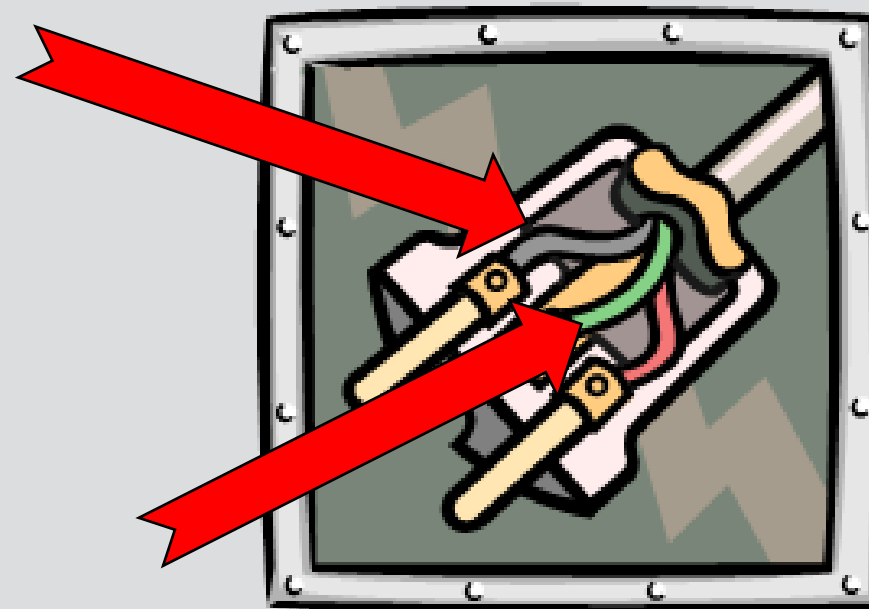

NC Central
UNIVERSITY

Environmental Health and Safety

Wiring Design and Protection

No grounded conductor may be attached to any terminal or lead so as to reverse designated polarity

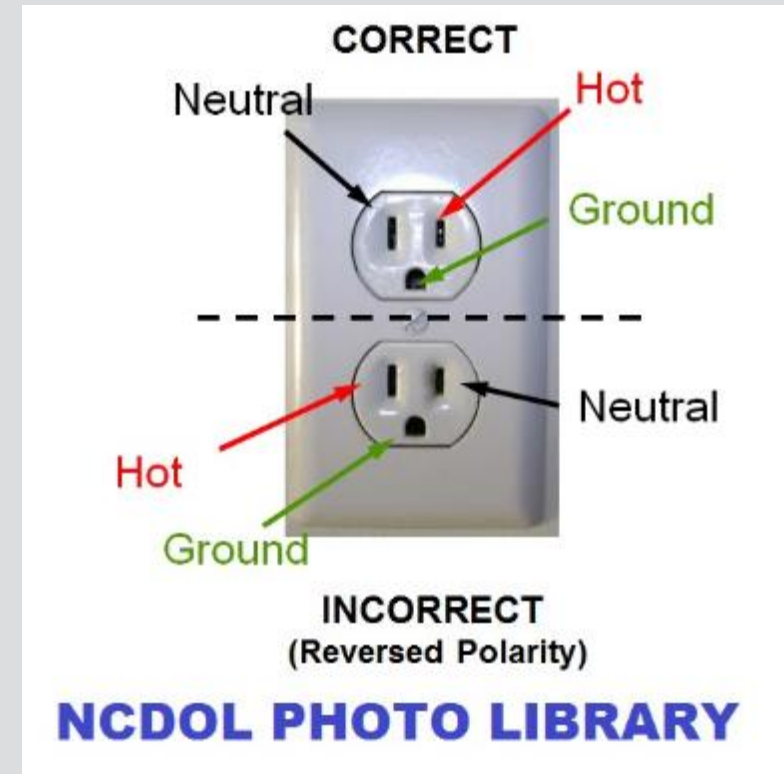
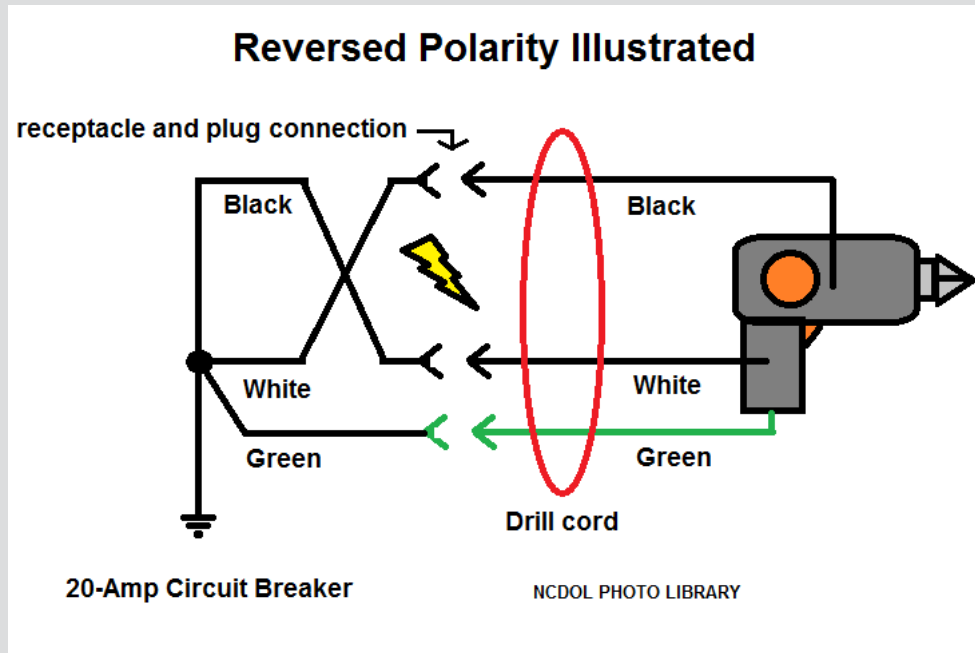

NC Central
UNIVERSITY

Environmental Health and Safety

Ground Fault Circuit Interrupter (GFCI)

- Detects difference in current between black and white circuit wires caused by current leakage which is known as a ground fault
- GFCI can shut off electricity flow in 1/40 of a second
- All 125-volt receptacles installed in bathrooms or on rooftops shall have GFCI protection
- For temporary wiring installations all 125-volt, single phase, 15 - 20 ampere, shall be GFCI protected during maintenance, remodeling or construction activities
- Cord sets and devices incorporating the required GFCI that are connected to the receptacle closest to the source of power are acceptable forms of protection



NC Central
UNIVERSITY

Environmental Health and Safety

Environmental Concerns



Unless identified for use in the operating environment, no conductors or equipment shall be

- Located in damp or wet locations
- Exposed to agents that have a deteriorating effect on the conductors or equipment
- Exposed to excessive temperatures



NC Central
UNIVERSITY

Environmental Health and Safety

Arcing parts

Parts of electric equipment that produce arcs, sparks, flames, or molten metal shall be enclosed or separated and isolated from all combustible material



Disconnecting Means (DM) and Circuits

- A DM is a switch used to disconnect the conductors of a circuit from the source
- Must be located in readily acceptable location
- Each service, feeder, and branch circuit, at its disconnecting means or over-current device, must be legibly marked to indicate its purpose
- Markings required shall be durable and withstand the environment



DM for Motor #3

Circuit breaker listing



NC Central
UNIVERSITY

Environmental Health and Safety

Example - Proper Labeling of System

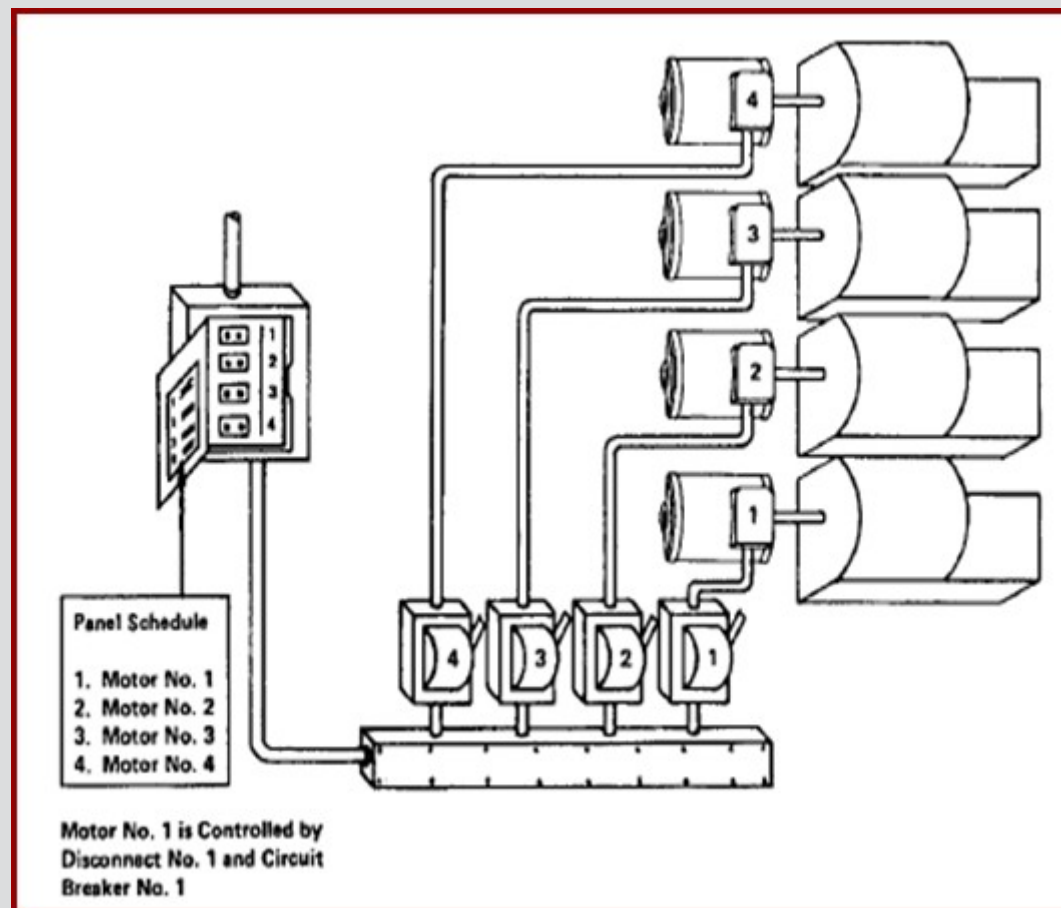

NC Central
UNIVERSITY

Environmental Health and Safety

Capable of Accepting a Lock

Disconnecting means shall be capable of being locked in the open position



NC Central
UNIVERSITY

Environmental Health and Safety



Lockout/Tagout (LOTO)

- Specific procedures to safeguard employees from the unexpected energization or startup of machinery and equipment and from the release of hazardous energy during service or maintenance
- Workers must complete the LOTO Awareness Level Training
 - Authorized persons for LOTO must complete an initial in-depth training to become authorized

Space Around Electrical Equipment

Condition A — Exposed live parts on one side and no live or grounded parts on the other side of the working space.

Condition B — Exposed live parts on one side and grounded parts on the other side.

Condition C — Exposed live parts on both sides of the workspace with the operator between.

Nominal voltage to ground	Minimum clear distance for condition ^{2,3}					
	Condition A		Condition B		Condition C	
	m	ft	m	ft	m	ft
0 - 150	10.9	13.0	10.9	13.0	0.9	3.0
151 - 600	10.9	13.0	1.0	3.5	1.2	4.0

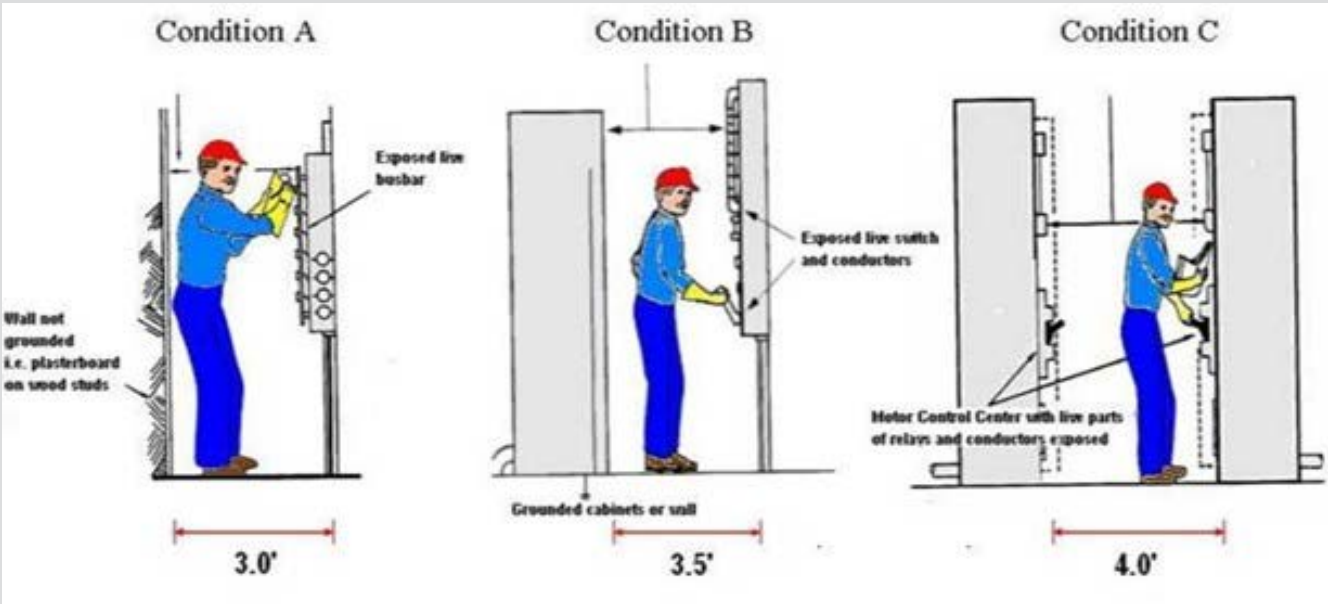

Minimum headroom around equipment is 6' 3"

Space Around Electrical Equipment



- Width of working space in front of the electric equipment shall be the width of the equipment or 762 mm (30 inches) whichever is greater
- Workspace shall be clear and extend from the grade, floor, or platform to the height required
- Never use this area for storage
- If located in general open area must be properly guarded



NC Central
UNIVERSITY

Environmental Health and Safety

Guarding Live Parts

- Live parts of electric equipment operating at 50 volts or more must be guarded
- Must enclose or guard electrical equipment exposed to physical damage
 - Approved cabinet/enclosure
 - Location in a room or vault accessible only to qualified persons
 - Permanent, substantial partition or screen accessible only to qualified persons
 - Elevation of 8 feet or more above floor or working surface
- Mark all entrances to guarded locations with conspicuous warning signs



NC Central
UNIVERSITY

Environmental Health and Safety

Wiring in Ducts

- No wiring systems of any type may be installed in ducts used to transport dust, loose stock, or flammable vapors



NC Central
UNIVERSITY

Environmental Health and Safety

Receptacles and Cord Connectors

Receptacles installed on 15- and 20- ampere branch circuits shall be of the grounding type



← Pre-1959

Post-1959 →



Receptacles and Cord Connectors

20A receptacles are the most common – they can be differentiated from 15A by the “T” shaped slot. Always verify at the breaker, however!



NC Central
UNIVERSITY

Environmental Health and Safety

Outlet Devices – Safety Factor of 20%

Maximum Cord- and Plug- Connected Load to Receptacle

Circuit rating (amperes)	Receptacle rating (amperes)	Maximum load (amperes)
15 or 20	15	12
20	20	16
30	30	24



A receptacle shall not be overloaded

Determining amperage for a device

- To determine the amperage of a device when not indicated on the label, use Watt's Law ($I \text{ (Amps)} = P \text{ (Watts)} / V \text{ (Volts)}$)

What is Watt's law?

- $P = \text{Watts}$
- $V = \text{Voltage}$
- $I = \text{Amps}$

To Find Desired Value
Cover Letter and Perform Math

$$P = I \times E$$
$$V = P / I$$
$$I = P / E$$

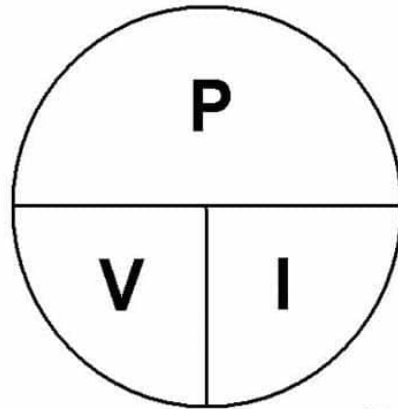

NC Central
UNIVERSITY

Environmental Health and Safety

Conductors Entering Cabinets, Boxes or Fittings

- Conductors entering boxes, cabinets, or fittings shall be protected from abrasion
- Must be run through a clamp or rubber grommet which effectively closes the opening through which the conductor passes
- All pull boxes, junction boxes and fittings must be covered and identified for the purpose
- Any metal covers must be grounded
- Each outlet box must have a cover, faceplate or fixture canopy
- NOTE – per NC Fire Code all electrical junction boxes **must** be covered and open splices are prohibited

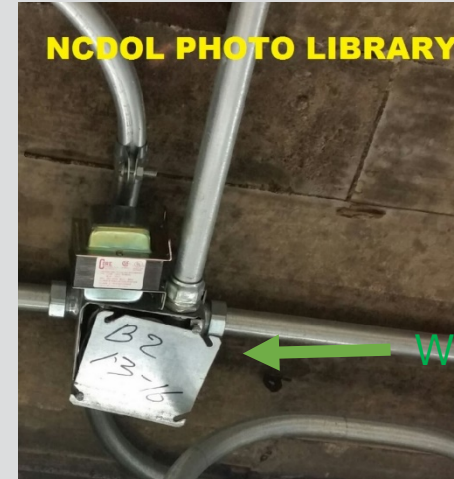

NC Central
UNIVERSITY

Environmental Health and Safety

Circuit Breakers

- Must clearly indicate whether they are in the open (off) or closed (on) position
- Two single-pole breakers should only be combined by an *approved* means when permissible – whenever possible, double-pole breakers should be used instead



NC Central
UNIVERSITY

Environmental Health and Safety

Clues that Hazards Exist

- Tripped circuit breakers or blown fuses
- Warm tools, wires, cords or connections
- GFCI shuts off a circuit
- Worn or frayed insulation around wire or connection



NC Central
UNIVERSITY

Environmental Health and Safety

Flexible Cords

Never use if recognized wiring method can be used

- Yes

- Pendant or fixture wiring
- Portable lamps, tools or appliances
- Stationary equipment to facilitate interchange

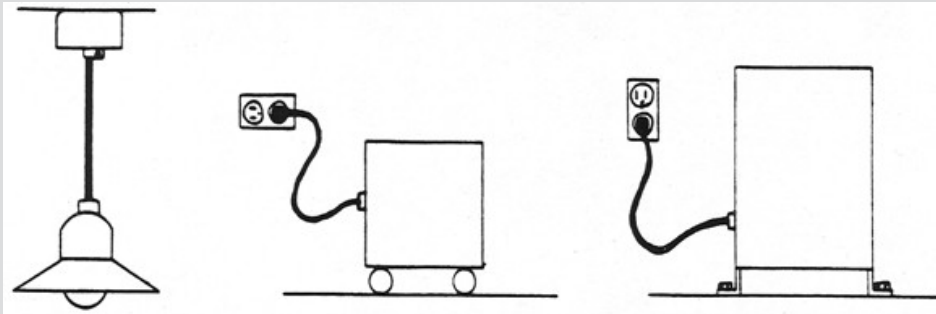

- No

- As a substitute for fixed wiring
- Run through walls, ceilings, floors, doors or windows
- Concealed behind or attached to building surfaces

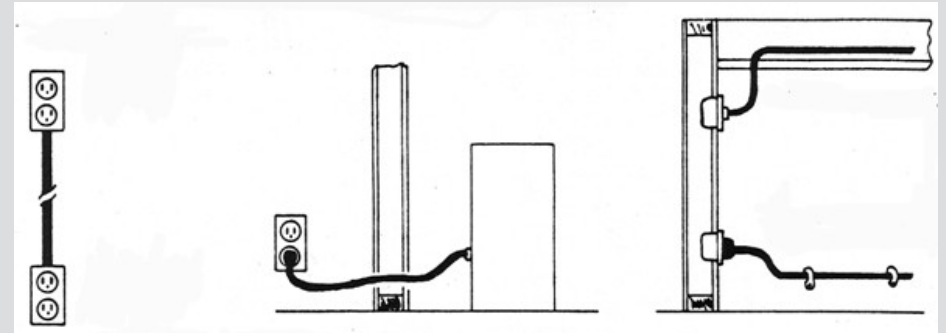

NC Central
UNIVERSITY

Environmental Health and Safety

Extension Cords

- Use NRTL approved cords
- Check for wear and tear before use
- Do not modify in any way
- Use 3-wire extension cords
- Remove cord from receptacles by pulling on the plug – not the cord
- NEVER run through walls, ceilings or floors



NC Central
UNIVERSITY

Environmental Health and Safety

Hand Held Tools



- Portable electrical equipment often used in highly conductive work locations (wet or damp areas)
 - Ensure that equipment is properly rated
- Potential danger because they make continuous good contact with hand
- Flexible cords are more prone to damage than fixed wiring
 - Always protect against cutting or damaged insulation or connections
- To properly protect against injury tools must
 - Have 3-wire cord with ground and be plugged into grounded receptacle; or
 - Be double insulated; or
 - Be powered by a low-voltage isolation transformer



NC Central
UNIVERSITY

Environmental Health and Safety

Fall Hazards

Item to Evaluate	Yes	No
Is there a proper scaffold or work platform?		
Is the scaffold or work platform of a non-conductive material?		
Does the work platform have proper guard railing (top edge height between 39 and 45 inches)?		
Does scaffold or work platform have screens or mesh to protect tools from falling into or near the electrical system?		
If a ladder is used, is it of non-conductive material?		
Does scaffold have toe boards to prevent tools and other loose equipment from falling?		
On a suspension or scissor scaffold, are electrical wires properly insulated and free of damage?		
Is there adequate clearance between the scaffold or ladder and power lines?		
Is the scaffold free of dust and debris?		
Are fall arrest systems used?		
Is the scaffold or ladder free of moisture, snow and ice?		

If electrical work requires working at height (roof or ceiling work, tree trimming) use the Fall Hazard Checklist to evaluate potential hazards that could cause a fall in the event of an electrical incident

Power Lines

- Overhead and buried power lines carry dangerously high voltage
- Overhead are generally not insulated
- Always look for overhead power lines and buried power line indicators
- Stay at least 10 feet away from overhead power lines and **assume they are energized**
- Use non-conductive wood or fiberglass ladders when working near power lines

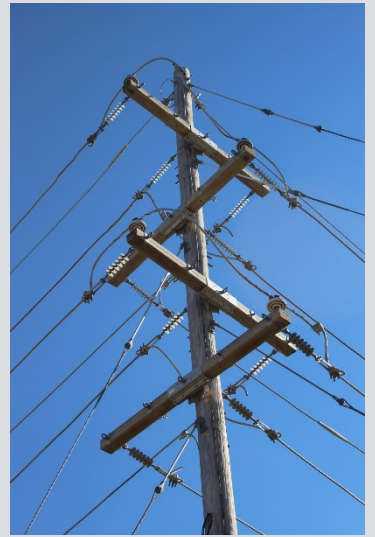

Generators

- DO NOT operate a generator indoors. Generators should be placed outdoors in a location where the exhaust gases cannot enter building
- Be sure main circuit breaker is OFF and locked out prior to starting any generator
- Turn off generators and let them cool prior to refueling



Services Over 600 volts

- Must be guarded to make them accessible only to qualified persons
- Install proper signage where others might come in contact with live parts
- Overcurrent devices must be available to each employee
- May not be located where they will be exposed to physical damage or near easily ignitable material
- Fuses and circuit breakers located or shielded so that employees are not injured by operation



Electrical Safety Rule Re-cap

- Design and plan for safe work - identify hazards and anticipate problems
- Resist *hurry-up* pressure
- Always consider electrical equipment energized until **positively** shown otherwise
- Safest way to inspect, test, or making repairs is on de-energized equipment
 - Know and apply LOTO when equipment is de-energized
 - Positively ensure the correct circuit is identified before LOTO
- Use suitably rated electrical tools and devices only as intended
- Remove jewelry before performing energized electrical work
- Know how to isolate energy to equipment in an emergency
- Maintain covers, barriers, and shielding of all electrical equipment
- Never penetrate wiring conduit or enclosed wire ways
- Use proper PPE for job

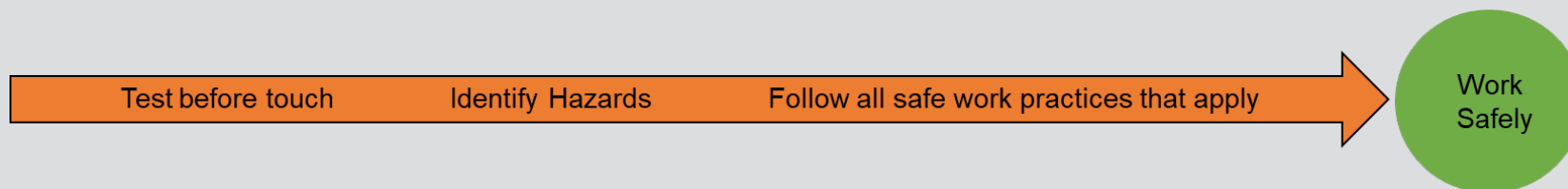

Questions

Department of Environmental Health and Safety

(919) 530-7125

ehs@nccu.edu

[*nccu.edu/ehs*](http://nccu.edu/ehs)



NC Central
UNIVERSITY

Environmental Health and Safety