



Electrochemical Corrosion Rate Measurement – A Comparison

Dr David Loveday
Gamry Instruments
www.gamry.com



Overview

- Corrosion Testing Theory
- Polarization Resistance (LPR)
- Electrochemical Frequency Modulation (EFM)
- EIS
- Comparison

Why Are Electrochemical Techniques Used for Corrosion Measurement?

- Corrosion is an electrochemical, or “**redox**”*, process involving **electron transfer**.



*redox = reduction-oxidation

- A broad range of electrochemical techniques have been developed specifically for corrosion measurement.
- Electrochemical techniques are fast.
- Electrochemical techniques are sensitive.
- Can be used in the lab or in the field.

Electrochemical Techniques are Fast!

- Corrosion is an inherently slow process. A typical corrosion rate is 10 milli-inches per year (mpy) or 0.254 millimeters per year (mmpy) or 254 microns per year.
- The “best” corrosion tests are weight loss measurements after exposure. However, they are very slow (weeks, months, or years).
- Electrochemical instruments **polarize** the sample to accelerate the corrosion process and make the measurement in minutes or hours.

Electrochemical Techniques Are Sensitive!

- Electrochemical techniques can measure very low corrosion rates.
- A sample with a low corrosion rate will exhibit a low current during the electrochemical experiment. Corrosion scientists often use “rate” and “current” interchangeably.
- Electrochemical instruments can be designed to measure low currents very accurately. A 1 cm² iron sample with a corrosion rate of 1 mpy (milli-inch per year) will exhibit a current in the range of 2-5 μA , which can be measured very accurately by a modern **potentiostat**.
- 4 milli-inches corresponds roughly to the diameter of a human hair.

A Review of Electrochemistry

Electrochemistry – The study of chemical reactions accompanied by the exchange of electrons. Electron-transfer is always a factor in electrochemistry. Additional chemistry is sometimes a factor in electrochemistry.

Oxidation: Loss of electrons $\text{Fe} \longrightarrow \text{Fe}^{2+} + 2 \text{e}^{-}$

Reduction: Gain of electrons $2\text{H}^{+} + 2\text{e}^{-} \longrightarrow \text{H}_2$

(Remember that LEO (the lion) says GER!)

General Echem Reaction: $\text{Ox} + \text{ne}^{-} \longrightarrow \text{Red}$

The Oxidized species accepts an electron to form the Reduced species.

Redox Reactions (Half-Reactions) in Corrosion

Oxidation: The Metal Being Tested



Reduction: Usually Some Solution Species

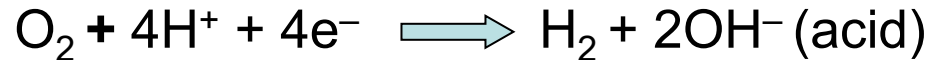
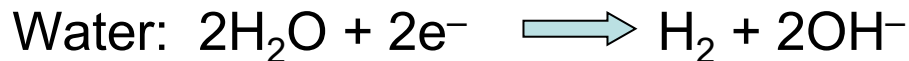

- Oxidation is *always* accompanied by Reduction in both the Real World and the electrochemical experiment.

What is Potential?

Potential or Voltage (E, sometimes V):

- Unit: **Volt (milliVolt, microVolt)**
- The Potential is the driving force for the redox reaction.
- The potential is related to the thermodynamics of the system:
$$\Delta G = -n F \Delta E \quad (\text{negative } \Delta G \text{ is spontaneous})$$
- Potential is always measured versus a Reference Electrode.
- A more positive voltage is more oxidative and a more negative voltage is more reductive.
- 0 Volts is not nothing! Redox reactions happen at 0 volts that do not happen at +1 volt.

Remember: There is no correlation between the thermodynamics of the chemical system and the kinetics (rate) of the reaction.

What is Current?

Current (i or I):

- Unit: **Ampere (mA, μ A, nA, pA, fA)**
- Electron flow is the result of a redox reaction.
- Current measures the **rate** of the reaction (electrons *per* second).
- Zero current is nothing, i.e., if the current is zero, no redox reactions are occurring (that's not quite true in corrosion!).
- Anodic (oxidation) and cathodic (reduction) currents have different polarity (signs).
- Current may be expressed as current or current density.
- Don't worry about which way the current flows.

A Simple Description of Potential and Current as a Flowing Water Circuit

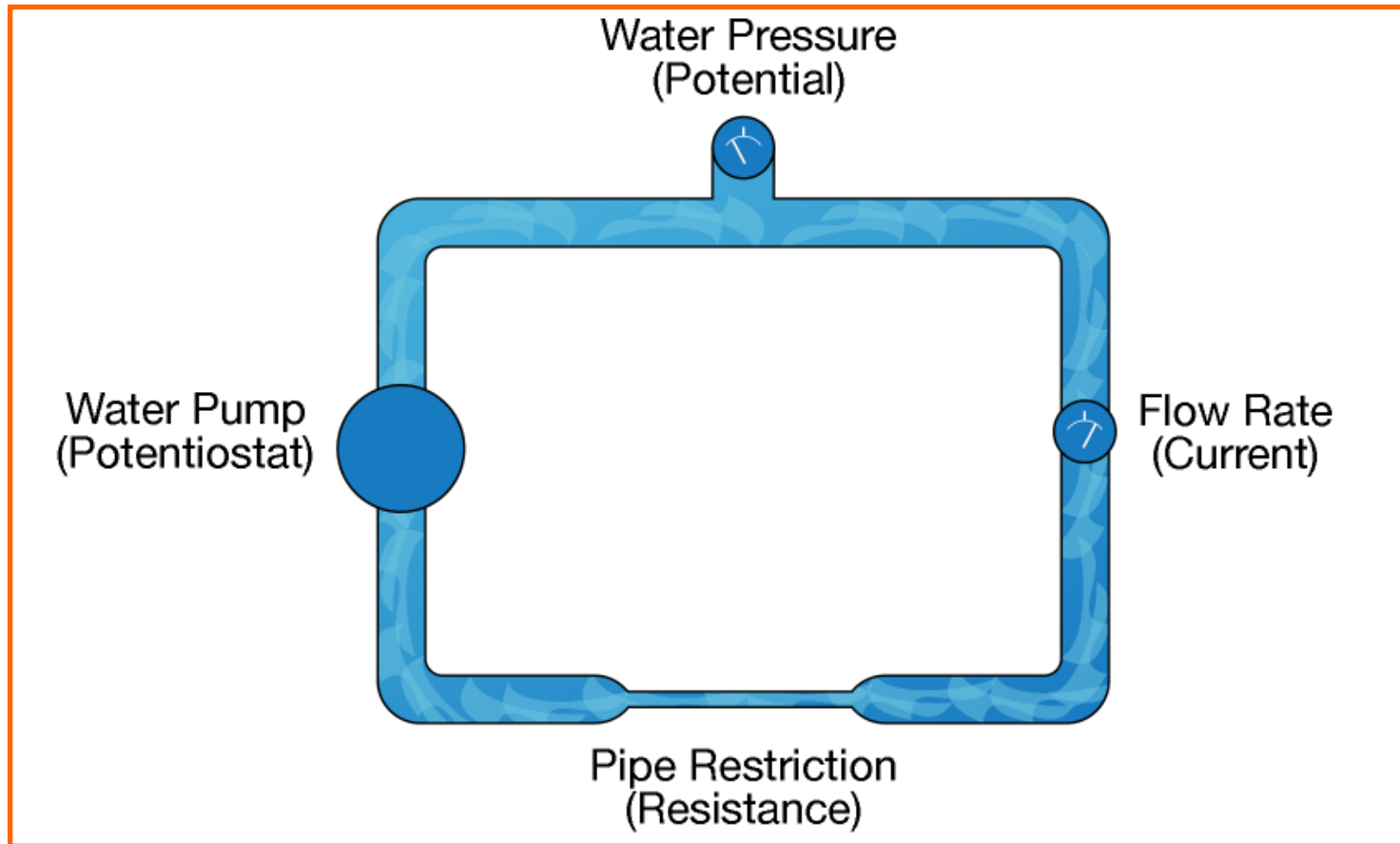

Range of Potential and Current that is Encountered in Corrosion Experiments

- 95% of electrochemical corrosion experiments take place within ± 2 volts vs. SCE.
- Current can vary from hundreds of milliamps to femtoamps (10^{-15} amps). That's 12-13 *orders of magnitude*! Modern potentiostats are capable of auto-ranging the current over 7-11 decades of current, which makes your life relatively easy.

Electrochemical Techniques

Electrochemistry is simple in principal...there are only three variables: potential (E), current (i), and time.

“Active Experiments”: Apply an excitation, measure a response. Make something happen!

- Potentiostatic: Apply & Control E, Measure i, Plot E vs. i or i vs. t
- Galvanostatic: Apply & Control i, Measure E, Plot i vs. E or E vs. t

“Passive Experiments”: Observe the experiment electrochemically.

- Potentiometric: Measure E at $i=0$ (pH Meter, open circuit measurement)
- Zero Resistance Ammeter (ZRA): Measure i between two connected electrodes. (galvanic corrosion, electrochemical noise)
- Active experiments give faster results, but risk changing the sample.

Controlled Potential (Potentiostatic) Experiments are Most Commonly Used in the Corrosion Lab

- In most electrochemical corrosion experiments, the potential is controlled. Because of the relationship between the potential and the thermodynamics of the system, controlled potential experiments are more informative than controlled current experiments.
- The (three-electrode) **Potentiostat** is the electronic instrument that controls the potential between the **Working Electrode** (your sample!) and the Reference Electrode while it measures the current between the **Working Electrode** and the **Counter Electrode**.
- Why three electrodes? A three-electrode Potentiostat allows potential control and current measurement at the Working Electrode with no “interference” from other electrochemical events in the cell.
- To perform an electrochemical measurement, we change the potential in some systematic way and measure the current response. The applied potential may allow a redox reaction to occur and the current will be indicative of the rate (kinetics) of the reaction.

The 3-Electrode Electrochemical Cell

- **Working** Electrode: Corrosion sample being studied
 - Active area should be known
 - **Reference** Electrode: Saturated Calomel (SCE) or Silver-Silver Chloride (Ag/AgCl)
 - Pseudo-reference may be acceptable
 - **Counter** Electrode: Should be conductive and inert (Graphite or Platinum).
-
- Solution may be stirred and deaerated to remove O_2 , or saturated with CO_2 or H_2S
 - Temperature control is encouraged! Rates of chemical reactions are very temperature dependent!

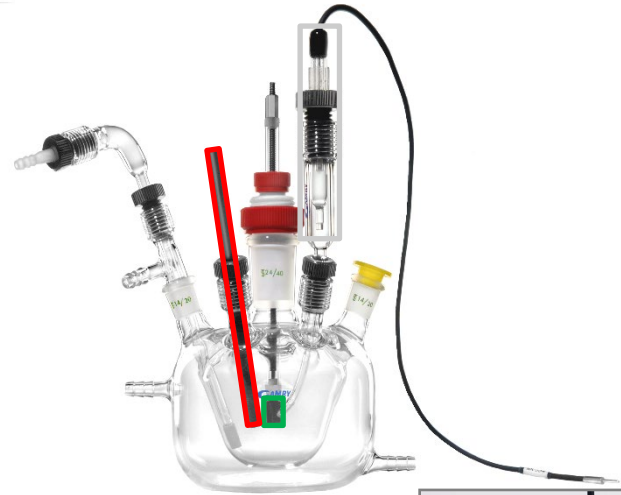

The Open Circuit Potential

- The Open Circuit Potential, E_{OC} , is the potential difference between the metal Working Electrode and the Reference Electrode when immersed in the electrolyte.
- E_{OC} is a “mixed potential” whose value is determined by the potentials of the two or more half-reactions of the electrochemical system, *not* by the potentiostat!
- E_{OC} is where corrosion occurs in service.
- E_{OC} is the starting point for virtually all electrochemical corrosion experiments. A stable E_{OC} is taken to indicate that the corroding system has reach a “steady state” and the experiment may begin. This may require minutes to days.

The Open Circuit Potential

- No measurable current is flowing at E_{OC} . If we apply a potential equal to E_{OC} with our potentiostat, the current will be zero.
- An applied voltage that is positive of E_{OC} will accelerate an oxidation (corrosion) reaction. An applied voltage that is negative of E_{OC} will accelerate a reduction reaction. This makes life somewhat easy.
- The terms " E_{OC} " and " E_{corr} " (corrosion potential) are often used interchangeably.
- The value of the E_{OC} is not particularly useful as a predictive tool.

Quantitative Corrosion Rate Measurements

- Polarization Resistance , Electrochemical Frequency Modulation, EIS and (Tafel Plots) are experiments designed to measure the rate of uniform corrosion in units of penetration (mmpy or mpy).
- Designed to measure the corrosion current, I_{CORR} , from which we can calculate the corrosion rate.
- Unlike weight loss, electrochemical techniques provide a “snapshot” of the corrosion rate.
- Should be performed when the system has reached “steady state”, indicated by a stable E_{OC} .
- Note: “Linear Polarization Resistance (LPR)” is not a correct term, but we use it anyway. The correct term is “Polarization Resistance”. (See CORROSION, November 2005.)

Corrosion Current, I_{corr}

- At E_{OC} , $i_{\text{meas}} = 0$, but we know that corrosion is occurring.



- We need to somehow measure the current due to the anodic or cathodic half-reaction. This current is called the Corrosion Current, I_{CORR} .
- The goal of the Polarization Resistance experiment is to determine the Corrosion Current.
- From the Corrosion Current, we can calculate corrosion rate.
- Don't forget the electrode area! i_{CORR} is usually current (A) and I_{CORR} is usually current density (A/cm²).

Precision of Electrochemical Corrosion Rate Measurements

- Corrosion is a messy business!
 -Dr. Jerry Frankel
 The Ohio State University
- Corrosion is a surface process involving a large number of variables that are difficult to understand and/or control.
- A Relative Standard Deviation of 15% is Excellent!
- A minimum of 3 replicates is recommended for corrosion measurements. (“Increase Your Confidence in Corrosion Test Data”, Steve Tait, MATERIALS PERFORMANCE, March 2001)

Error as a Function of Sample Size

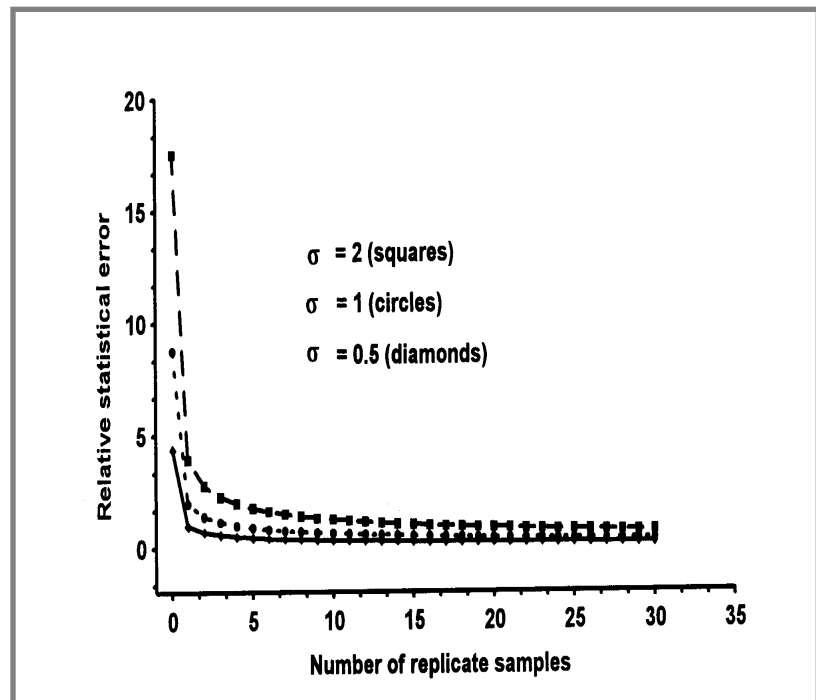

Comments on the Precision of Electrochemical Corrosion Measurements

- Electrochemical instrumentation is very accurate (<0.5% error)
- High purity Fe polished to a mirror finish gives great results!
- When corrosion occurs, anodic and cathodic reactions are occurring simultaneously on the surface of the sample
- The surface of a metal sample is *not* homogeneous. In fact, it may be *very* heterogeneous.
- The anodic and cathodic sites may “turn on” or “turn off” and move around as the local environment changes
- Electrolyte impurities can also affect the results
- The corrosion environment is very dynamic and the result is...poor precision



Electrochemical Corrosion Measurements are based on good solid science developed over many years.

So we'll touch very briefly on the theoretical aspects of electrochemical corrosion measurement.

Mixed Potential Theory

The principal of charge conservation requires that there must be a least one reduction and one oxidation in an electrochemical reaction.

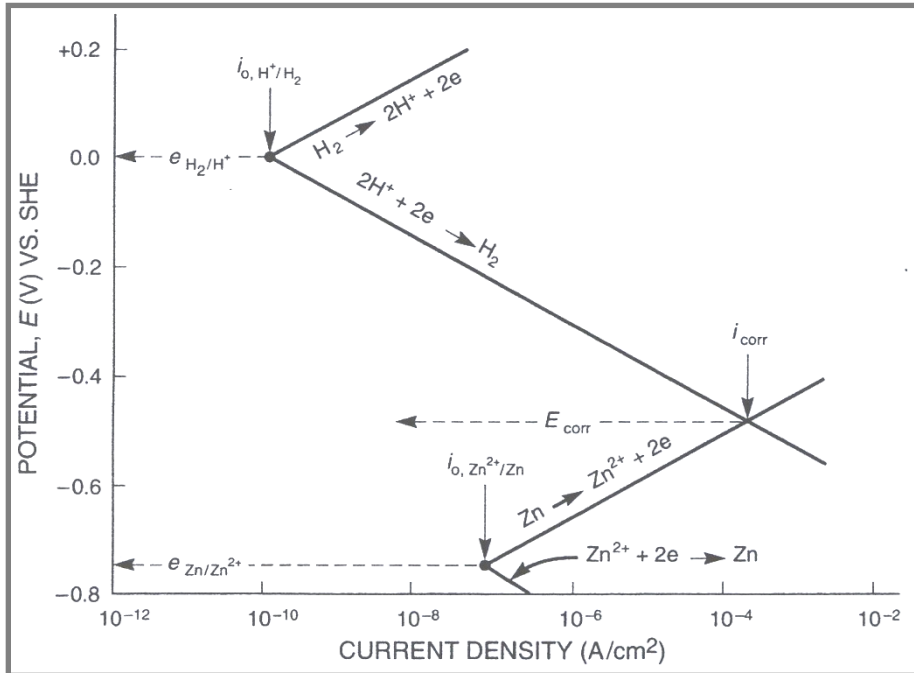

- $2\text{H}^+ + 2\text{e}^- \longrightarrow \text{H}_2$
- $\text{Zn} \longrightarrow \text{Zn}^{2+} + 2\text{e}^-$
- The anodic current equals the cathodic current at i_{corr} .
- Both reactions must occur on the same surface, so their potentials must shift to a common value, which is E_{corr} (same as E_{OC}).
- This is an example of a “mixed potential system” and E_{OC} is called a “mixed potential”.

“Principles and Prevention of Corrosion”, Jones

Note: The log X axis may sometimes be labeled “APPLIED CURRENT DENSITY”. Don’t let this confuse you!

Butler-Volmer Equation

The Butler-Volmer Equation is a general electrochemical equation that describes the relationship between the potential and the current (kinetics) in a mixed potential system.

$$I = I_a + I_c = I_{CORR} \left(e^{(2.3(E-E_{oc})/\beta_a)} - e^{(-2.3(E-E_{oc})/\beta_c)} \right)$$

Where:

I = cell current (A)

I_{CORR} = corrosion current (A)

E = applied potential (V)

E_{oc} = corrosion potential (V)

β_a = anodic Tafel constant (V/decade)

β_c = cathodic Tafel constant (V/decade)



Rate of anodic reaction

Rate of cathodic reaction

Graphical Representation of the Butler-Volmer Relationship between Potential and Current in a Mixed Potential System

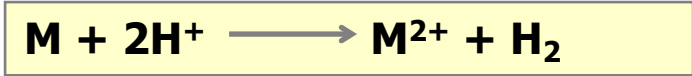
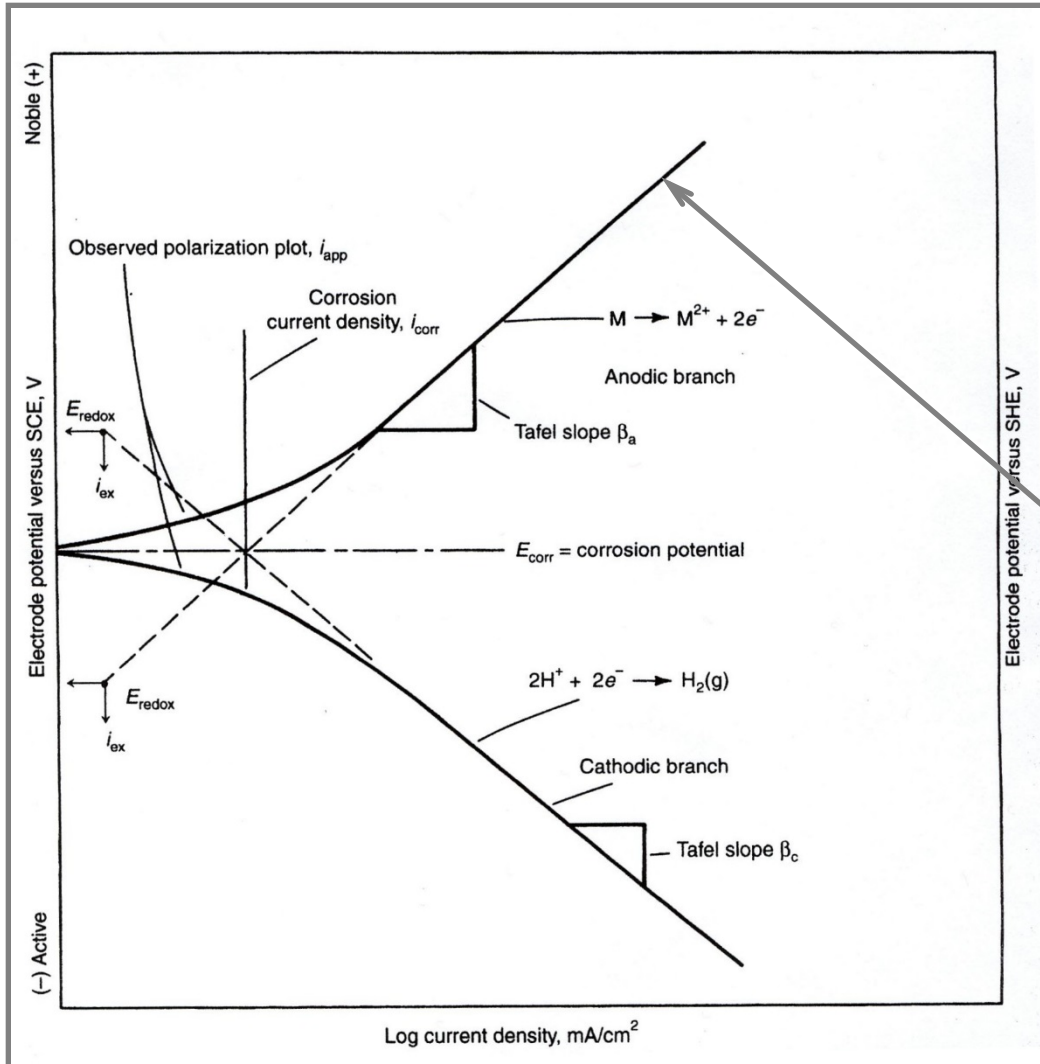

An experiment like this is called a "Tafel Plot" and is relatively common in today's corrosion laboratory.

Experimental data from the corrosion measurement system.

J. Scully & R. Kelly, ASM Handbook, Volume 13A, 2003.

Butler-Volmer Equation

The Butler-Volmer Equation only holds if:

- The rate is charge-transfer controlled (aka, activation-controlled, electron-transfer controlled). Complicating factors are:
 - Passivity
 - Diffusion-controlled (concentration polarization)
 - Adsorption
- Only one reduction and one oxidation reaction are occurring (first order)
 - Alloys can be complicated
- If the Butler-Volmer equation doesn't hold, then the electrochemical response will not be “classic” and must be interpreted in terms of the chemistry of the system.

Stern-Geary Equation and Polarization Resistance

- The purpose of the Polarization Resistance experiment is to determine the Polarization Resistance (R_p).
- The Stern-Geary Equation describes the relationship between the Polarization Resistance (R_p) and the Corrosion Current (i_{CORR}).
- $R_p = \Delta E / \Delta i = \beta_a \beta_c / 2.3 i_{CORR} (\beta_a + \beta_c)$
- **IMPORTANT:** The Stern-Geary Equation is derived from the Butler-Volmer Equation via a series expansion in which $\Delta E / \beta_{a,c}$ is assumed to be less than 0.1.
- Therefore, in the Polarization Resistance technique, the applied potential should be within $\pm 5-10$ mV of E_{oc} .
- The plot of potential vs. current is approximately linear in this region.

The Polarization Resistance Experiment

GAMRY
INSTRUMENTS

Experimental Procedure for Polarization Resistance

1. Measure E_{OC} and allow to stabilize.
2. Apply initial E that is 10 mV negative of E_{OC} .
3. Scan at a slow scan rate (~ 0.125 mV/s) to a final E that is 10 mV positive of E_{OC} .
4. Measure current, plot E (Y-axis) versus I (X-axis)
5. Measure slope, which has units of resistance ($E/i = R$).
6. Convert R_p to i_{corr} using the Stern-Geary Equation.
7. Convert i_{corr} to Corrosion Rate.

Polarization Resistance Carbon Steel

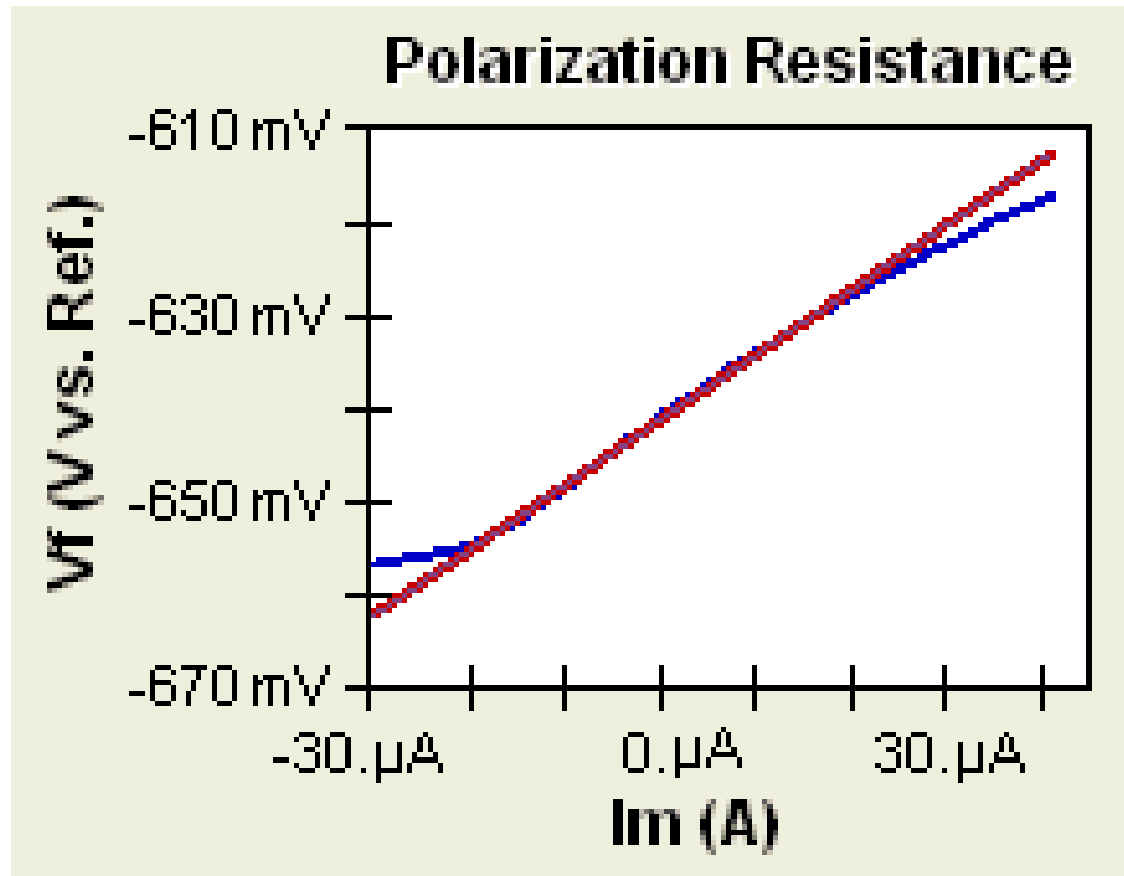

0.5M KCl (aq) solution

Calculation of i_{CORR} from R_P

Stern-Geary Equation

$$R_P = \Delta E / \Delta i = \beta_a \beta_c / 2.3 i_{CORR} (\beta_a + \beta_c)$$

Where

R_P = Slope at the origin of the Polarization Resistance Plot in ohms or ohms-cm²

i_{CORR} = Corrosion Current, Amperes or Amperes/cm².

β_a, β_c = Tafel Constants from a Tafel Curve, volts/decade of current.

Note: The area of the electrode must be taken into account somewhere!

I. Calculation of Corrosion Rate from I_{CORR}

Faraday's Law

$$Q = nFm/A = it$$

Q = coulombs (A-s/eq), n = number of electrons, F = the Faraday (96,487 coulombs/equivalent), m = mass (g), A = atomic weight, i = current (A), t = time (s).

Since Equivalent Weight (EW) = A/n,
 $m = it(EW)/F$

Corrosion Rate (g/s) = $m/t = i(EW)/F$

II. Calculation of Corrosion Rate from I_{CORR}

From the engineering standpoint, it is convenient to express Corrosion Rate in units of penetration, mpy (milli-inches per year), mmpy (mm per year), or microns per year.

Divide both sides of the equation

$$\text{Corrosion Rate (g/s)} = m/t = i(EW)/F$$

by electrode area and density,

$$\text{Corrosion Rate (cm/s)} = i(EW)/FdA$$

i/A = current density (I). After conversion of cm to inches or mm, and seconds to years,

$$\text{Corrosion Rate (mpy)} = 0.13 I_{\text{corr}} (EW)/d$$

$$\text{Corrosion Rate (mmpy)} = 0.00327 I_{\text{corr}}(EW)/d$$

Polarization Resistance Carbon Steel

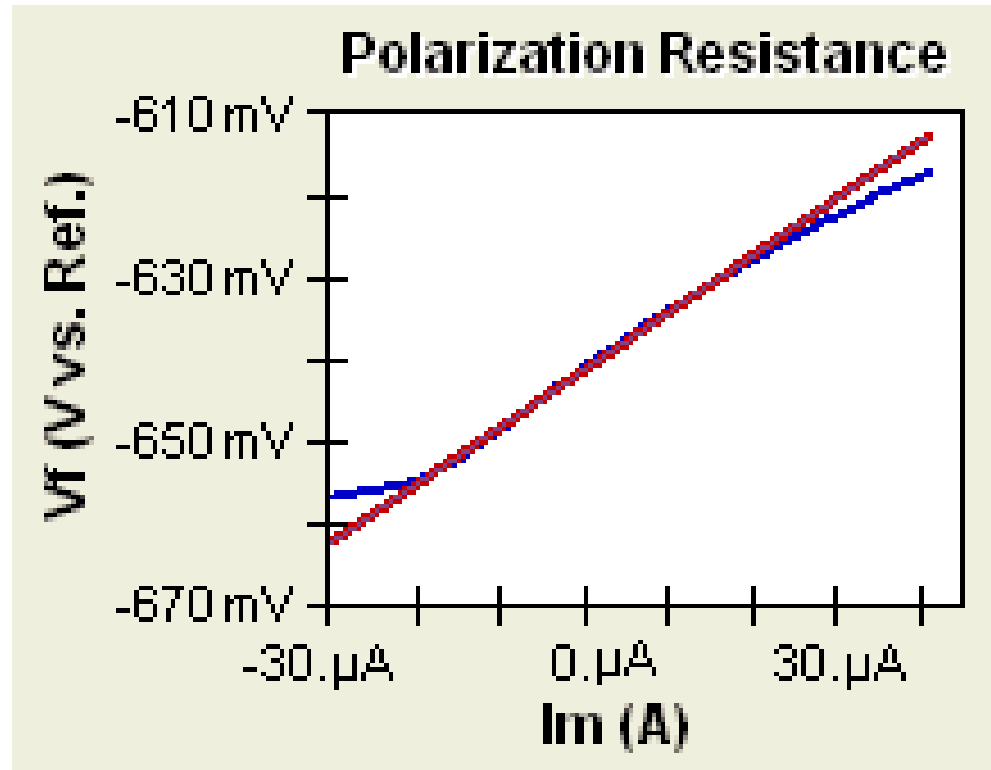

Corrosion rate = 6.07 mpy

Electrochemical Frequency Modulation

EFM

What is it?

- Apply 2 sine waves simultaneously
- Non-destructive
- Measure current vs. time response.

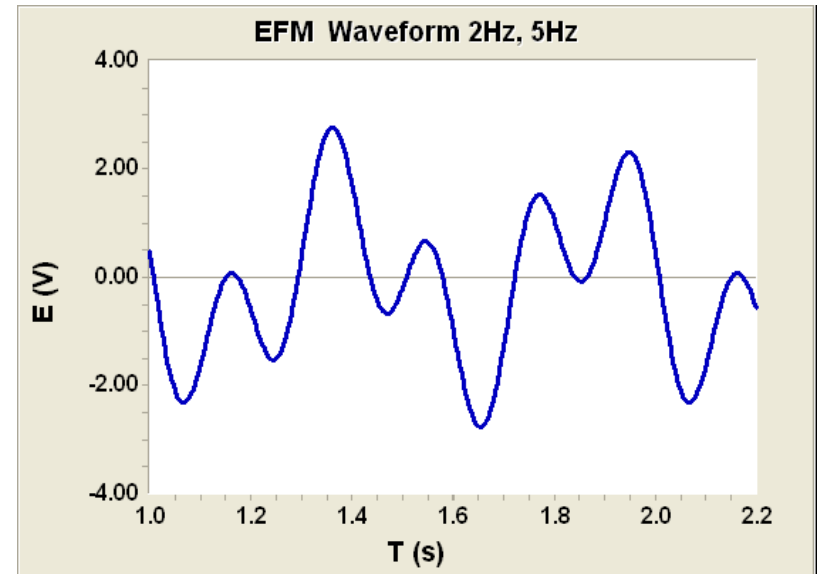

Theory

- Potential excitation
 - $\eta = V[\sin \omega_1 t + \sin \omega_2 t]$
- Butler-Volmer Response
 - Activation controlled (kinetics)
 - Non-linear!
 - $i = i_{corr} [e^{\eta/B_A} - e^{-\eta/B_C}]$

More Theory

- Waveform - $\eta = V[\sin At + \sin Bt]$
- Expand the exponentials using a Taylor expansion

$$- e^x = 1 + \frac{x}{1!} + \frac{x^2}{2!} + \frac{x^3}{3!} + \dots, \quad -\infty < x < \infty$$

- Trigonometry

$$- \cos(2x) = 2 \sin^2 x - 1$$

$$- \sin(3x) = 3 \sin x - 4 \sin^3 x$$

$$- \sin(x + y) = \sin x \cos y + \cos x \sin y$$

$$- \dots$$

And then A Miracle Occurs

- $i = a[\sin(At) + \sin(Bt)] + b [\cos(A - B)t - \cos(A + B)t] + c[\sin(2A - B)t - \sin(2A + B)t + \sin(2A + B)t - \sin(2B + A)t] + d[-\cos(2At) - \cos(2Bt)] + e[-\sin(3A)t - \sin(3B)t]$
 - Where a, b, c, d and e are the amplitudes at each frequency

An Example

- $A = 2 \text{ Hz}$, $B = 5 \text{ Hz}$
- None of the frequencies can be duplicated

		Freq	Amplitude
A	2	2	a
B	5	5	a
B-A	5-2	3	b
A+B	2+5	7	b
B-2A	5-2(2)	1	c
2B-A	2(5)-2	8	c
A+2B	2+2(5)	12	c
2A+B	2(2)+5	9	c
2(A)	2(2)	4	d
2(B)	2(5)	10	d
3(A)	3(2)	6	e
3(B)	3(5)	15	e

The EFM Experiment

What we do

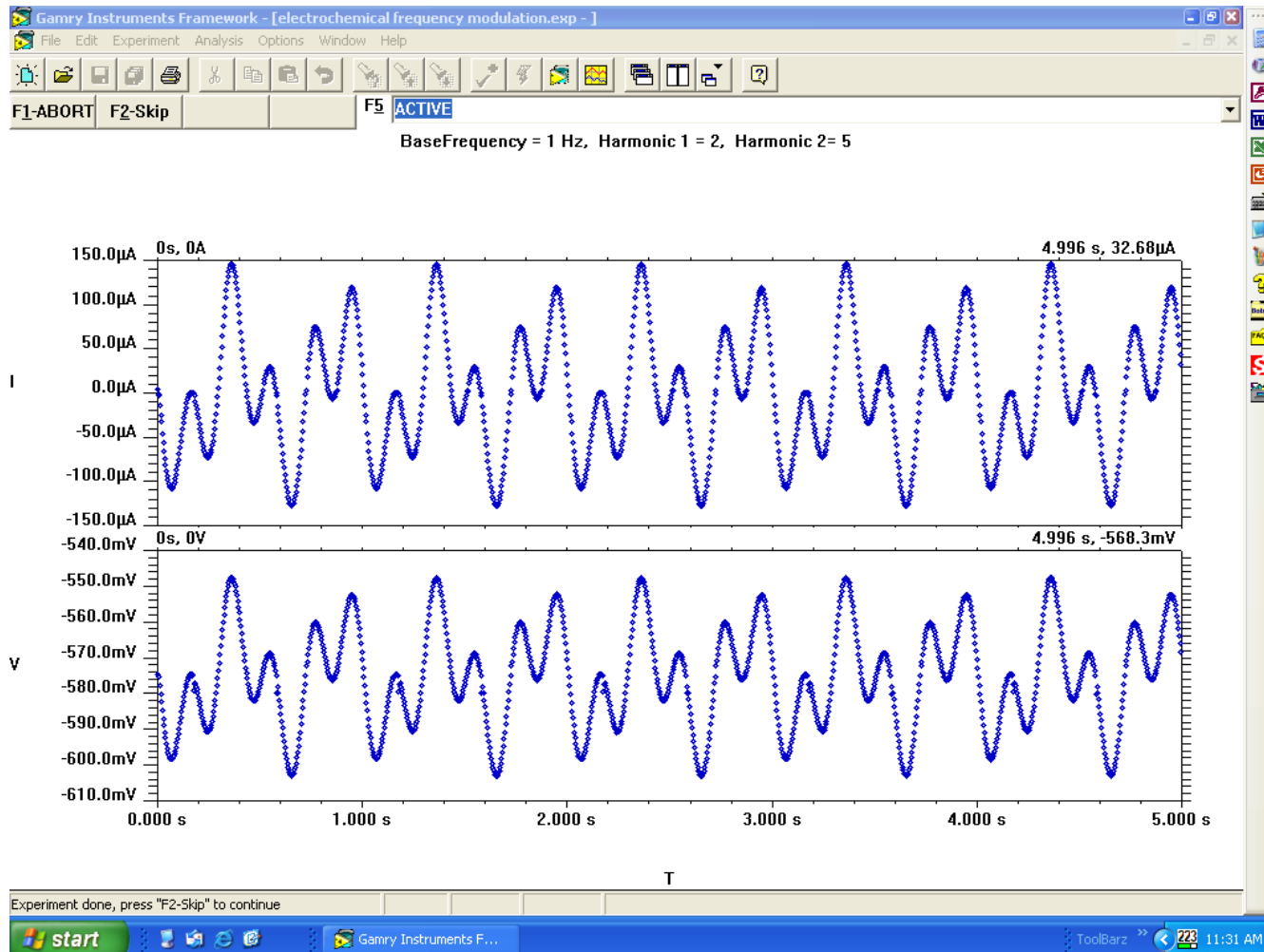

Intermodulation Spectrum

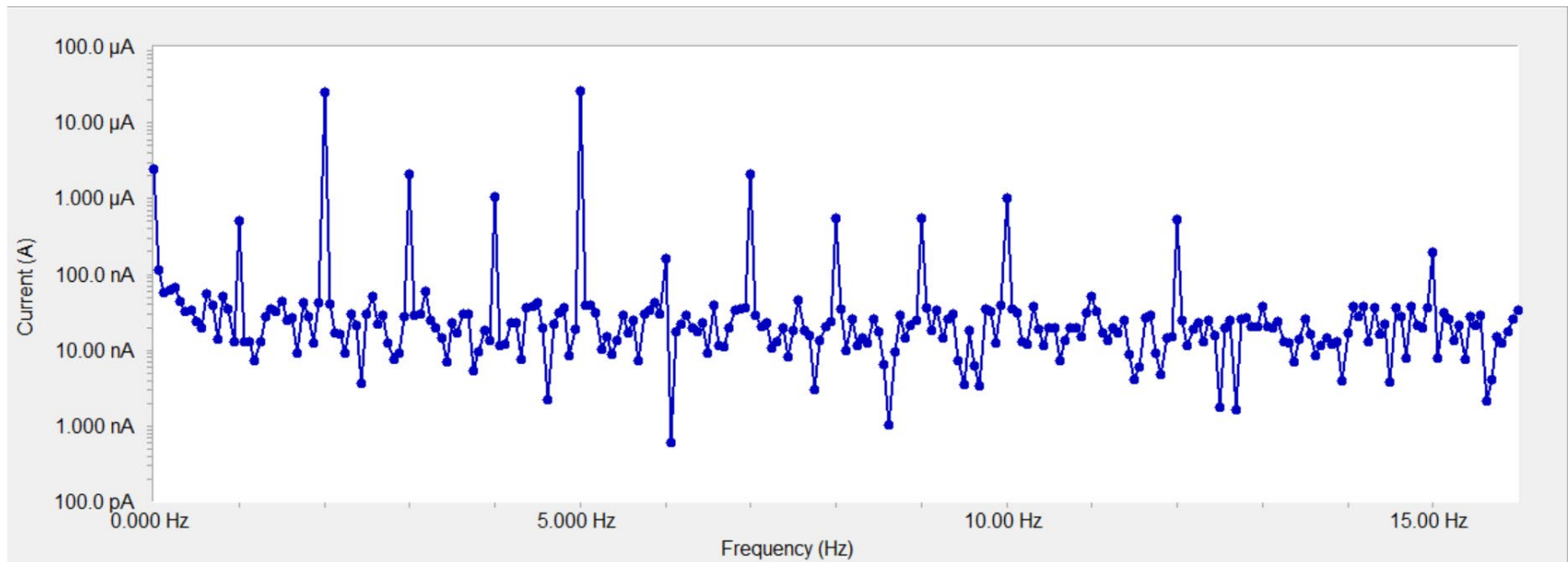

Theory

- With a,b,c,d and e you can calculate

– i_{corr}

– β_A

– β_C

a	$i_{corr} \{V/\beta_A + V/\beta_C\}$
b	$(1/4) i_{corr} \{ (V/\beta_A)^2 - (V/\beta_C)^2 \}$
c	$(1/24) i_{corr} \{ (V/\beta_A)^3 + (V/\beta_C)^3 \}$
d	$(1/2) i_{corr} \{ (V/\beta_A)^2 - (V/\beta_C)^2 \}$
e	$(1/8) i_{corr} \{ (V/\beta_A)^3 + (V/\beta_C)^3 \}$

Theory

- In addition to I_{corr} an internal quality check can be made by ratioing the amplitudes of the different harmonic and intermodulation peaks.
- d/b yields a value of 2 and e/c yields a value of 3
- These are independent of any variables

EFM of Carbon Steel

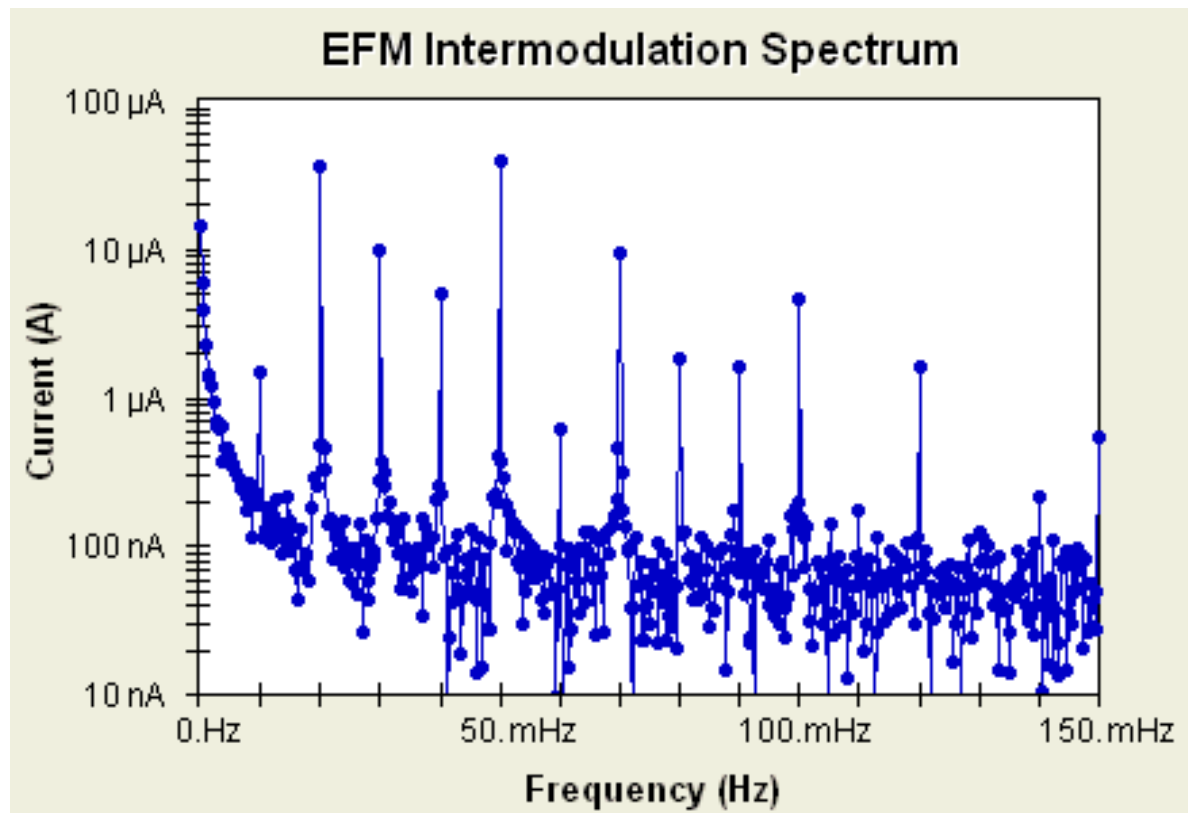

EFM of Carbon Steel

EFM Analysis (Active)	Results
I _{corr}	48.57 μA
Beta1	75.74e-3 V/decade
Beta2	377.0e-3 V/decade
Corrosion Rate	7.398 mpy
Causality Factor (2)	1.970
Causality Factor (3)	2.861

Electrochemical Impedance Spectroscopy: EIS

- Brief Overview of EIS
- EIS Results for Carbon Steel.

Electrochemistry as a Circuit

- Double Layer Capacitance
- Electron Transfer Resistance
- Uncompensated (electrolyte) Resistance

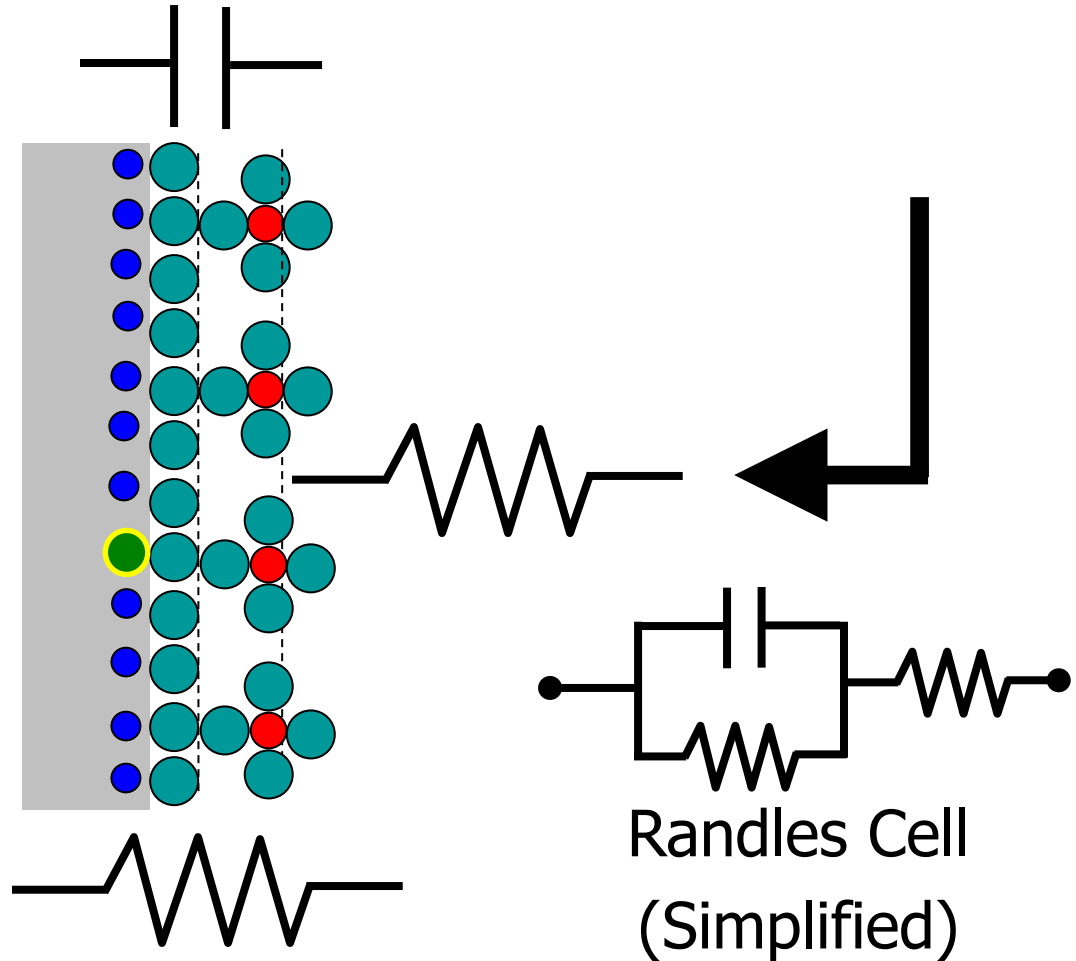

Bode Plot

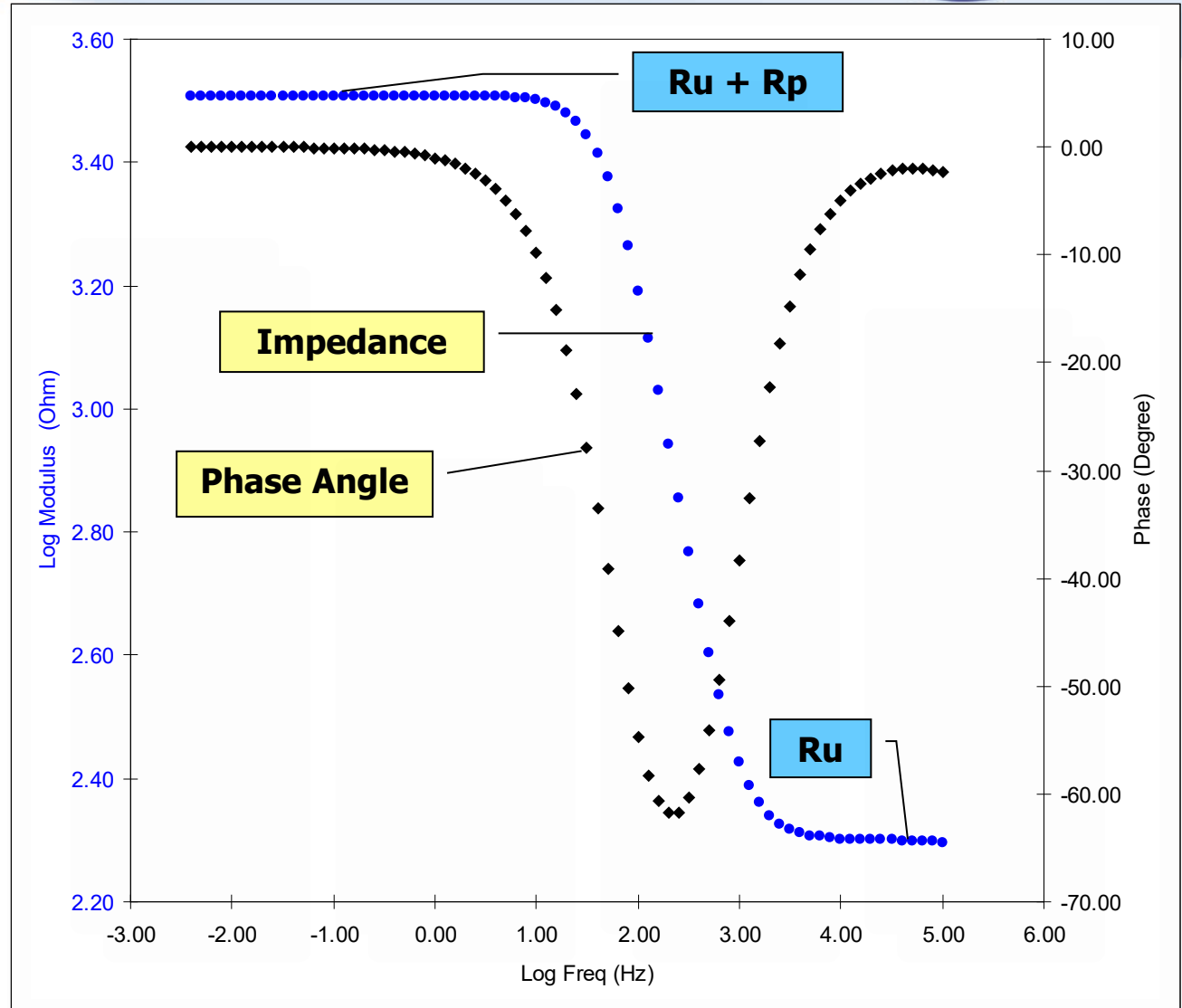
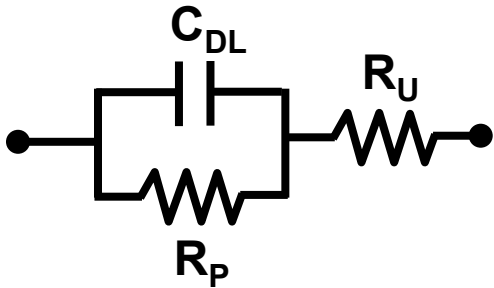

Complex Plane (Nyquist) Plot

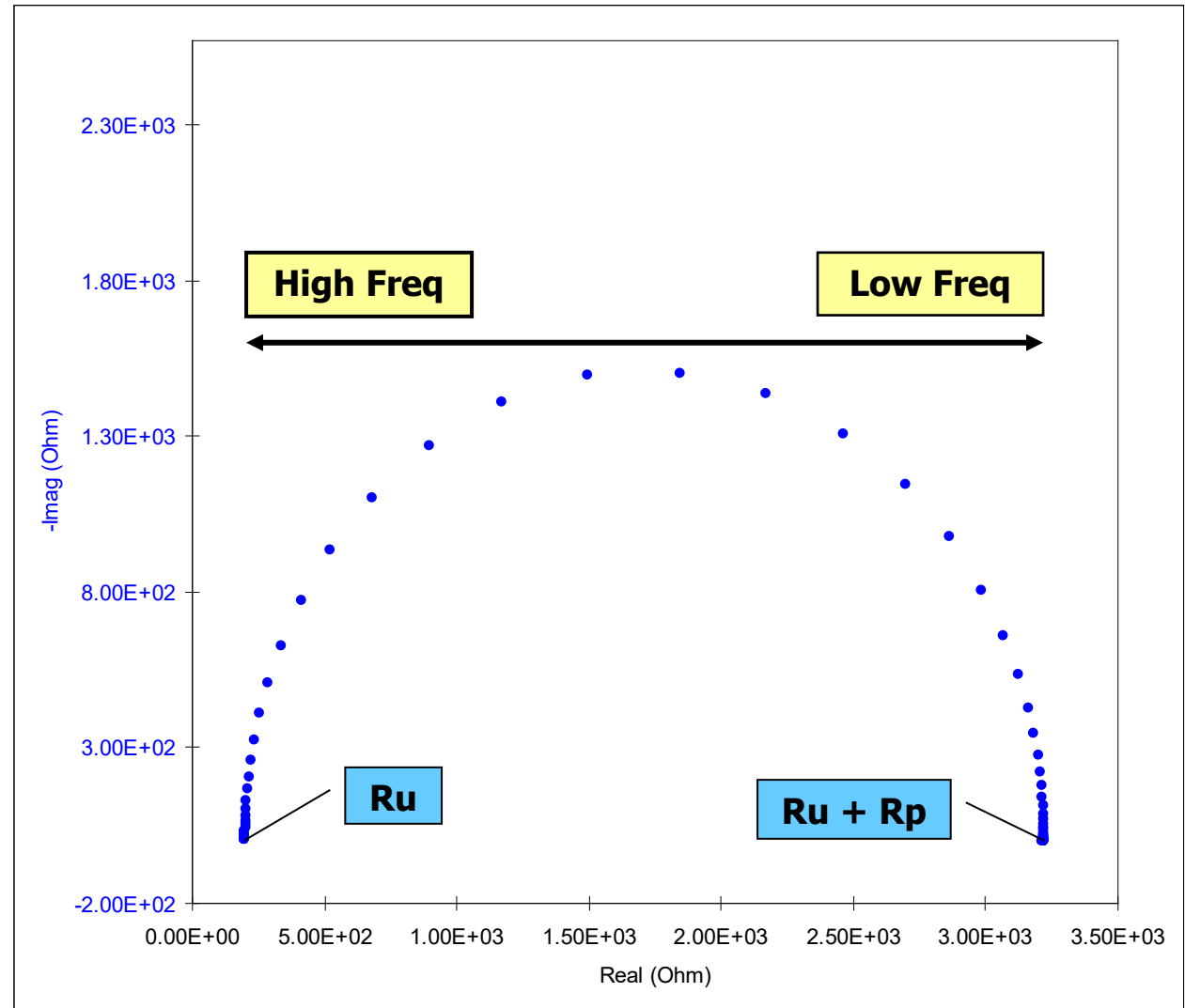
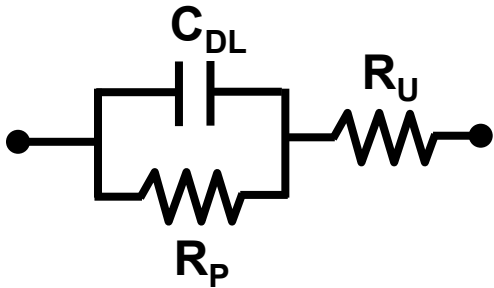

Nyquist Plot with Fit

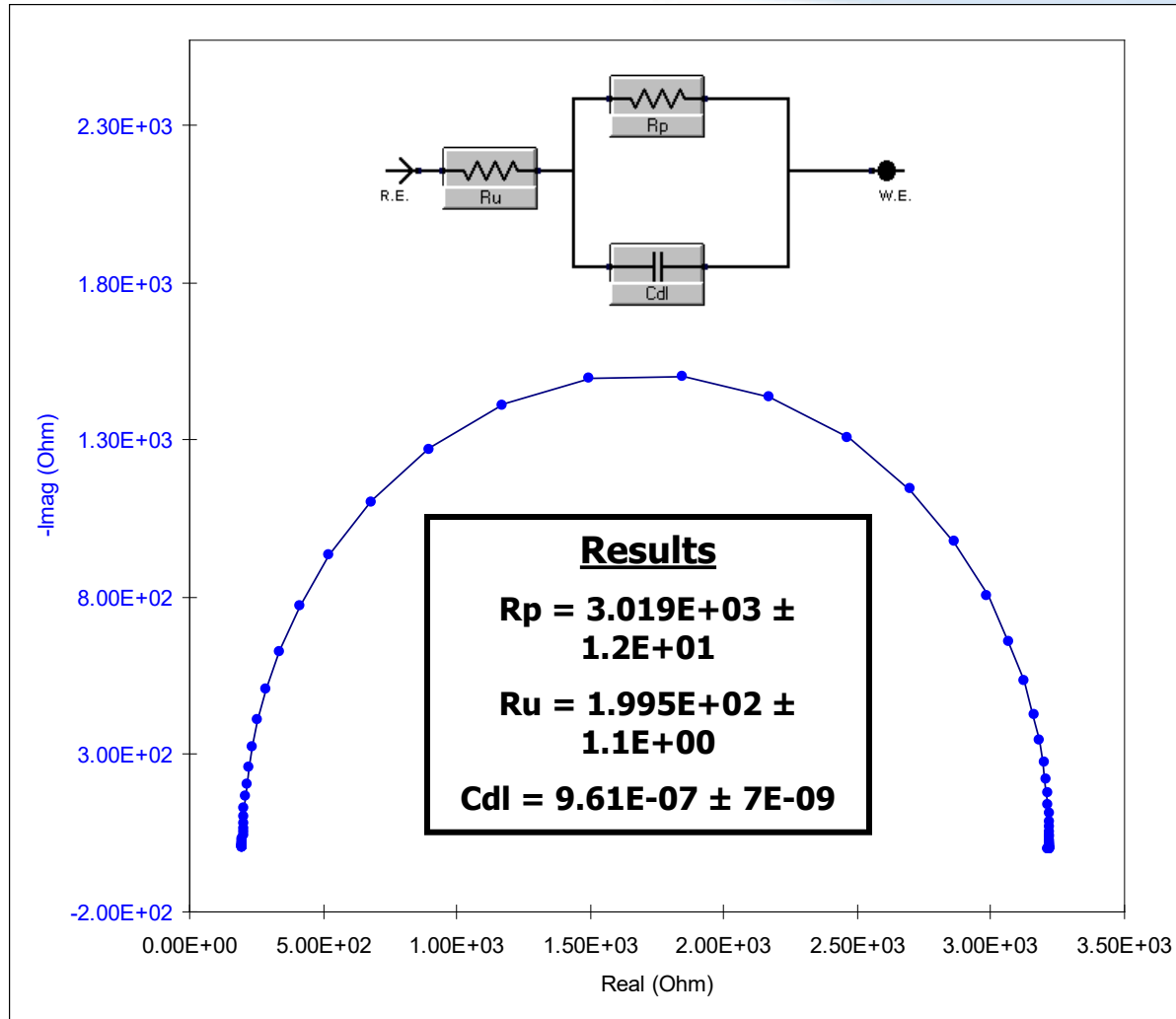

Criteria For Valid EIS

Linear – Stable - Causal

- **Linear:** The system obeys Ohm's Law, $E = iZ$. The value of Z is independent of the magnitude of the perturbation. If linear, no harmonics are generated during the experiment.
- **Stable:** The system does not change with time and returns to its original state after the perturbation is removed.
- **Causal:** The response of the system is due only to the applied perturbation.

Electrochemistry: A Linear System?

Circuit theory is simplified when the system is “linear”. Z in a linear system is independent of excitation amplitude. The response of a linear system is always at the excitation frequency (no harmonics are generated).

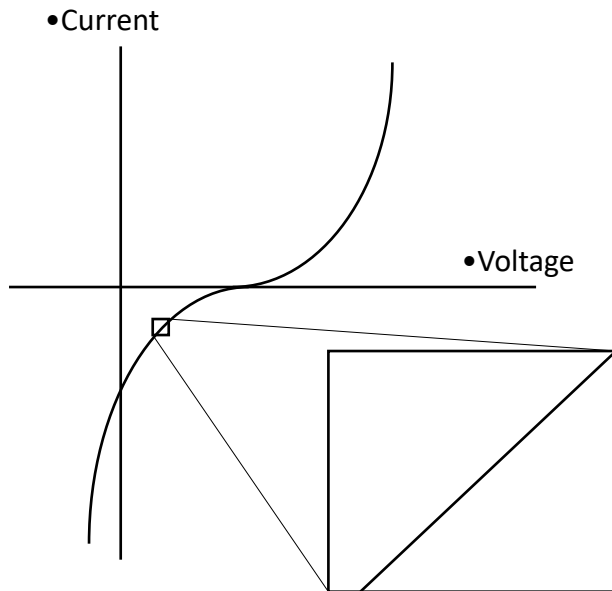

Look at a small enough region of a current versus voltage curve and it becomes linear.

If the excitation is too big, harmonics are generated and EIS modeling does not work.

The non-linear region can be utilized (EFM).

EIS of Carbon Steel

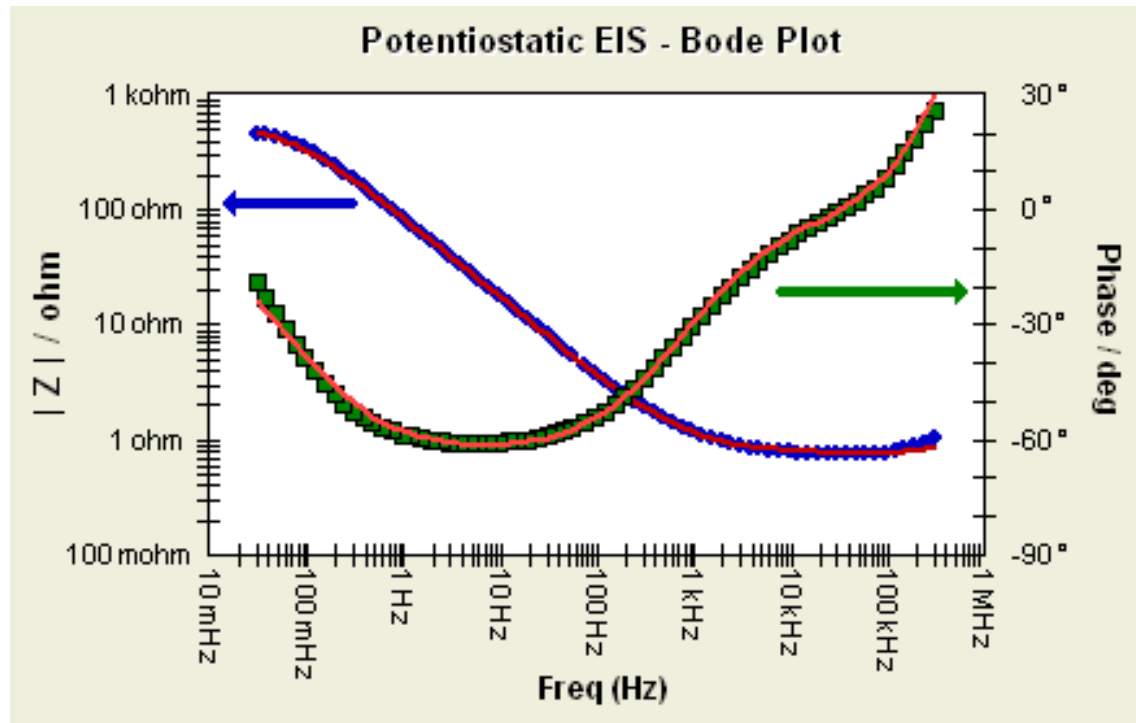

Combined Results

	LPR	EIS	EFM
Corrosion Rate mpy	6.07	6.20 (From Rp)	7.40
BetaA mV/decade	(From EFM)	(From EFM)	75.7
BetaC mV/decade	(From EFM)	(From EFM)	377
Polarization Resistance kohm-cm ²	2.06	2.02	

That's all, folks!

- Thank you for listening
- Question?