

**LECTURE NOTES
ON
ELECTRONIC CIRCUIT ANALYSIS**

B.Tech IV semester (IARE-R16)

**Mr J Siva Ramakrishna
(Assistant professor)**

**Mr C Srihari
(Assistant professor)**

**Ms Mary Swarnalatha
(Assistant professor)**

**Mr. K Ravi
(Assistant professor)**



**ELECTRONICS AND COMMUNICATION ENGINEERING
INSTITUTE OF AERONAUTICAL ENGINEERING**

**(Autonomous)
DUNDIGAL, HYDERABAD – 500043**

UNIT-I

Single Stage BJT Amplifier

Based on number of stages

Depending upon the number of stages of Amplification, there are Single-stage amplifiers and Multi-stage amplifiers.

- **Single-stage Amplifiers** –This has only one transistor circuit, which is a single stage amplification.
- **Multi-stage Amplifiers** –This has multiple transistor circuit, which provides multi-stage amplification.

Based on its output

Depending upon the parameter that is amplified at the output, there are voltage and power amplifiers.

- **Voltage Amplifiers** –The amplifier circuit that increases the voltage level of the input signal, is called as Voltage amplifier.
- **Power Amplifiers** –The amplifier circuit that increases the power level of the input signal, is called as Power amplifier.

Based on the input signals

Depending upon the magnitude of the input signal applied, they can be categorized as Small signal and large signal amplifiers.

- **Small signal Amplifiers** –When the input signal is so weak so as to produce small fluctuations in the collector current compared to its quiescent value, the amplifier is known as Small signal amplifier.
- **Large signal amplifiers** –When the fluctuations in collector current are large i.e. beyond the linear portion of the characteristics, the amplifier is known as large signal amplifier.

Based on the frequency range

Depending upon the frequency range of the signals being used, there are audio and radio amplifiers.

- **Audio Amplifiers** –The amplifier circuit that amplifies the signals that lie in the audio frequency range i.e. from 20Hz to 20 KHz frequency range, is called as audio amplifier.

- **Power Amplifiers** –The amplifier circuit that amplifies the signals that lie in a very high frequency range, is called as Power amplifier.

Based on Biasing Conditions

Depending upon their mode of operation, there are class A, class B and class C amplifiers.

- **Class A amplifier** – The biasing conditions in class A power amplifier are such that the collector current flows for the entire AC signal applied.
- **Class B amplifier** – The biasing conditions in class B power amplifier are such that the collector current flows for half-cycle of input AC signal applied.
- **Class C amplifier** – The biasing conditions in class C power amplifier are such that the collector current flows for less than half cycle of input AC signal applied.
- **Class AB amplifier** – The class AB power amplifier is one which is created by combining both class A and class B in order to have all the advantages of both the classes and to minimize the problems they have.

Based on the Coupling method

Depending upon the method of coupling one stage to the other, there are RC coupled, Transformer coupled and direct coupled amplifier.

- **RC Coupled amplifier** – A Multi-stage amplifier circuit that is coupled to the next stage using resistor and capacitor (RC) combination can be called as a RC coupled amplifier.
- **Transformer Coupled amplifier** – A Multi-stage amplifier circuit that is coupled to the next stage, with the help of a transformer, can be called as a Transformer coupled amplifier.
- **Direct Coupled amplifier** – A Multi-stage amplifier circuit that is coupled to the next stage directly, can be called as a direct coupled amplifier.

Based on the Transistor Configuration

Depending upon the type of transistor configuration, there are CE CB and CC amplifiers.

- **CE amplifier** – The amplifier circuit that is formed using a CE configured transistor combination is called as CE amplifier.
- **CB amplifier** – The amplifier circuit that is formed using a CB configured transistor combination is called as CB amplifier.

- **CC amplifier** – The amplifier circuit that is formed using a CC configured transistor combination is called as CC amplifier.

Simplified Common Emitter (CE) hybrid model

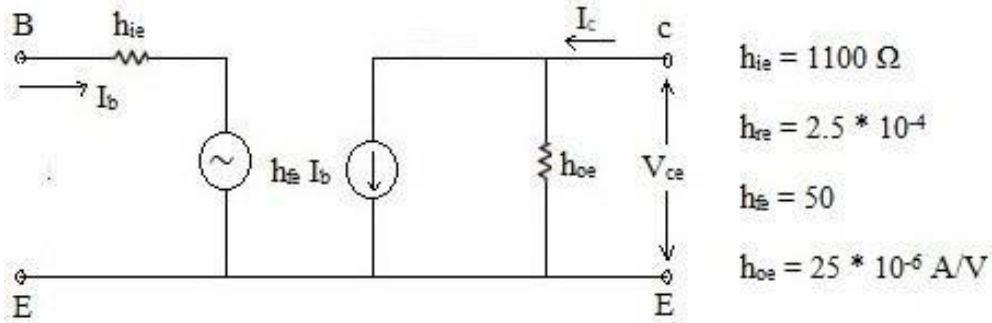

h_{re} and h_{oe} is very small they can be neglected.

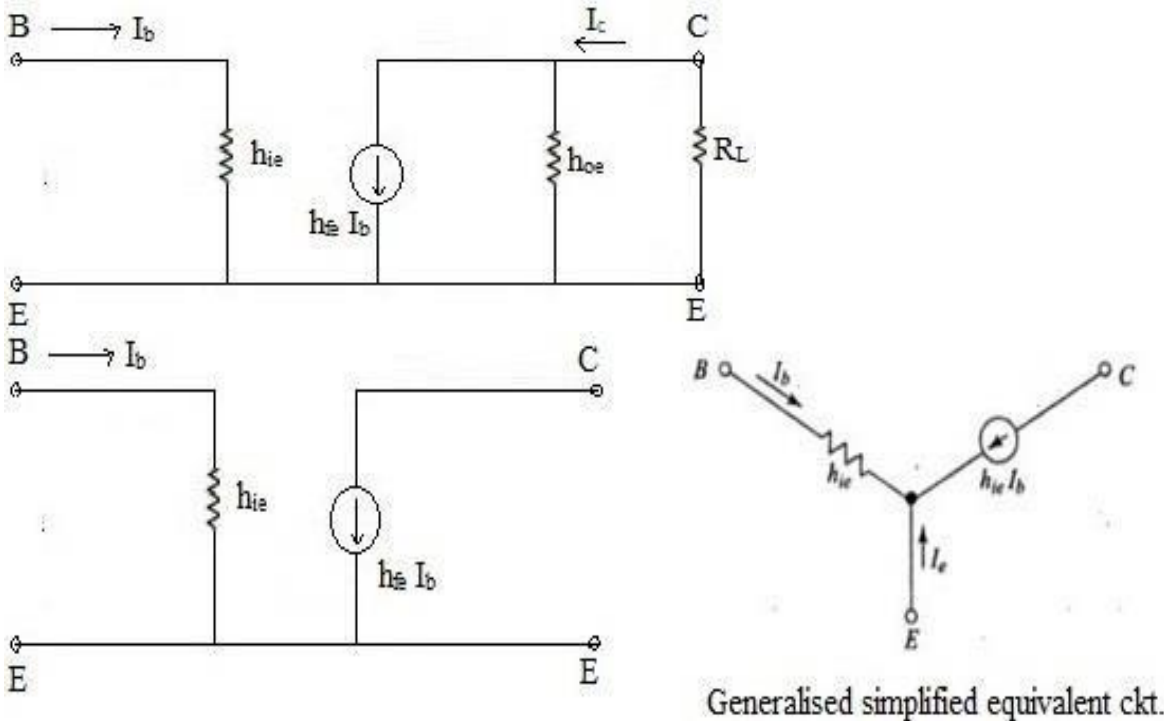

Analysis of Common Emitter (CE) amplifier using simplified equivalent ckt

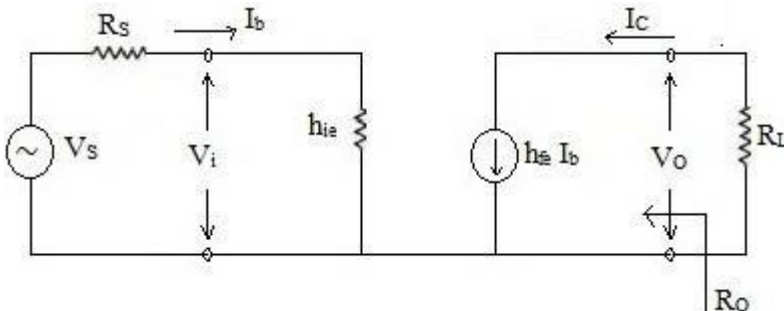

$$A_I = \frac{I_o}{I_b} = \frac{h_{fe} I_b}{I_b} = -h_{fe}$$

$$R_i = \frac{V_i}{I_b} = \frac{h_{ie} I_b}{I_b} = h_{ie}$$

$$A_V = \frac{V_o}{V_i} = \frac{I_o R_L}{h_{ie} I_b} = \frac{A_I R_L}{h_{ie}} = \frac{-h_{fe} R_L}{h_{ie}}$$

$$R_o = \frac{V}{I} \text{ Where } R_L = \infty, V_S = 0$$

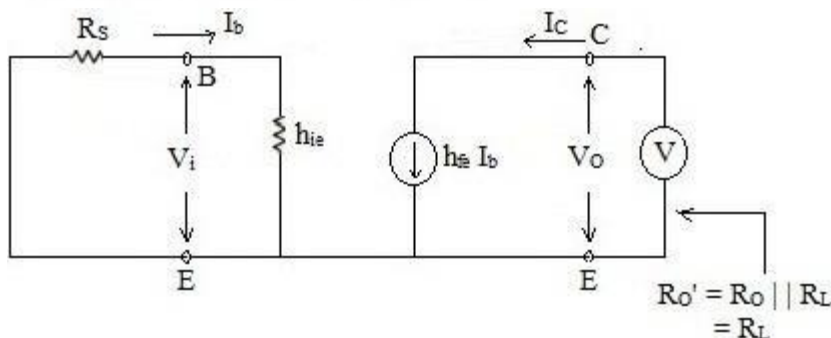

$$R_o = \frac{V}{I_c}$$

$$I_c = h_{fe} I_b$$

Apply KVL input side

$$R_s I_b + h_{ie} I_b = 0 \Rightarrow (R_s + h_{ie}) I_b = 0$$

It is possible only when $I_b = 0 \Rightarrow I_c = h_{fe} I_b = 0$

$$R_o = \infty$$

Response of BJT amplifier in Common Collector (CC) configuration using simplified hybrid model in CE configuration

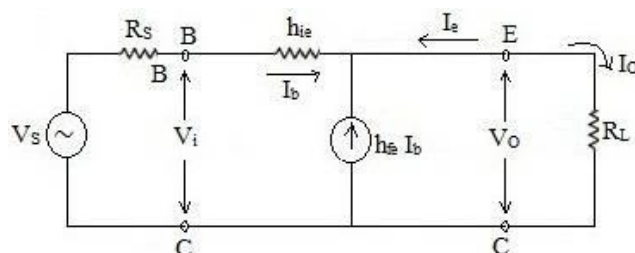

$$A_I = \frac{I_o}{I_b} = \frac{-I_e}{I_b} = \frac{(1+h_{fe})I_b}{I_b} = 1 + h_{fe}$$

$$R_i = \frac{V_i}{I_b} = \frac{h_{ie} I_b + (1 + h_{fe}) I_b R_L}{I_b} = h_{ie} + (1 + h_{fe}) R_L$$

$$A_V = \frac{V_o}{V_i} = \frac{I_o R_L}{I_b R_i} = \frac{A_I R_L}{R_i} = \frac{(1 + h_{fe}) R_L}{h_{ie} + (1 + h_{fe}) R_L}$$

$$\text{Also, } 1 - A_V = \frac{1 - (1 + h_{fe}) R_L}{h_{ie} + (1 + h_{fe}) R_L} = \frac{h_{ie}}{h_{ie} + (1 + h_{fe}) R_L}$$

$$1 - A_V = \frac{h_{ie}}{R_i} \quad \therefore \quad A_V = \frac{1 - h_{ie}}{R_i}$$

$$R_o = \frac{V}{I} \text{ when } R_L = \infty \text{ \& } V_S = 0$$

$$\frac{V}{I_e} = \frac{-I_e}{I_b} = \frac{-I_b (R_S + h_{ie})}{-I_b (1 + h_{fe})}$$

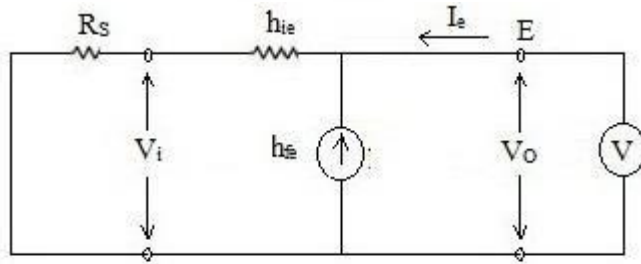

$$\therefore R_o = \frac{h_{ie} + R_S}{1 + h_{fe}}$$

Common Base (CB) Configuration

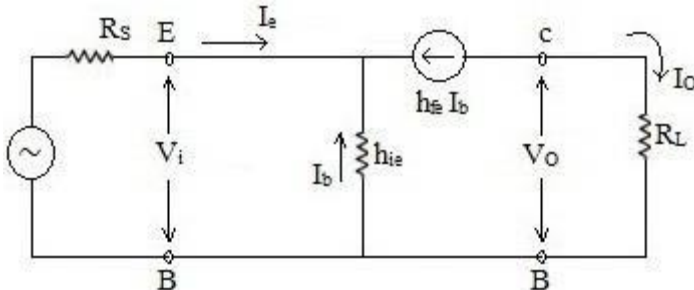

$$A_I = \frac{I_o}{I_e} = \frac{h_{fe}}{1 + h_{fe}}$$

$$R_i = \frac{V_i}{I_e} = \frac{h_{ie} I_b}{I_b (1 + h_{fe})} = \frac{h_{ie}}{1 + h_{fe}}$$

$$A_V = \frac{V_o}{V_i} = \frac{h_{fe} I_b R_L}{h_{ie} I_b} = \frac{h_{fe} R_L}{h_{ie}}$$

Comparison of CE, CC and CB

Quantity	CE	CC	CB
A_I	$-h_{fe}$	$1 + h_{fe}$	$h_{fe}/1 + h_{fe}$
R_i	h_{ie}	$h_{ie} + (1 + h_{fe}) R_L$	$h_{ie}/1 + h_{fe}$
A_V	$-h_{fe} R_L / R_i$	$(1 + h_{fe}) R_L / h_{ie} + (1 + h_{fe}) R_L$	$h_{fe} R_L / h_{ie}$
R_o	∞	$(h_{ie} + R_S) / 1 + h_{fe}$	∞
R	R_L	$R_o R_L$	R_L

CE amplifier with emitter resistance R_E

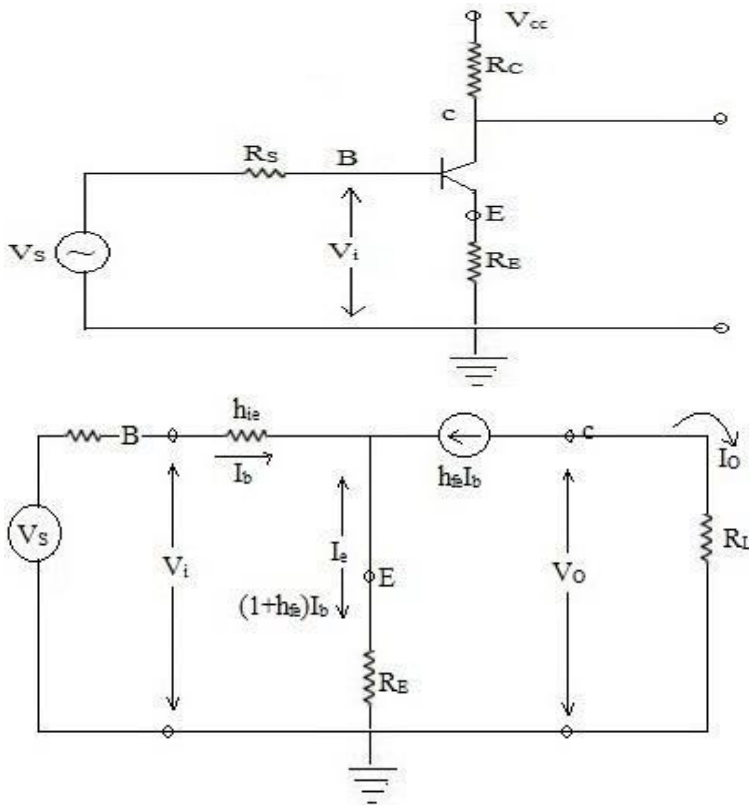

$$A_I = \frac{I_o}{I_b} = \frac{-h_{\beta} I_b}{I_b} = -h_{\beta} \text{ ----- (1)}$$

A_I without $R_E = -h_{\beta}$ (1 a)

Current gain is unaltered by one addition of amplifier resistance.

$$R_i = \frac{V_i}{I_b} = \frac{h_{ie} I_b + (1 + h_{\beta}) I_b R_E}{I_b} = h_{ie} + (1 + h_{\beta}) R_E \text{ ----- (2)}$$

R_i without $R_E = h_{ie}$ (2a)

This is a desirable effect produced by the addition of resistance R_E i.e. the input resistance is higher.

$$A_V = \frac{V_o}{V_i} = \frac{I_o R_L}{I_b R_i} = \frac{-h_{\beta} R_L}{h_{ie} + (1 + h_{\beta}) R_E}$$

Normally,

$$(1+h_{\beta}) R_E \gg h_{ie}$$

$$\text{Also } h_{\beta} \gg 1$$

Then,

$$A_V = \frac{-h_{\beta} R_L}{h_{\beta} R_E} = \frac{-R_L}{R_E}$$

So, the gain of the amplifier becomes the ratio of two resistances, and hence the gain is stabilized

Multi-stage amplifiers

In practical applications, the output of a single stage amplifier is usually insufficient, though it is a voltage or power amplifier. Hence they are replaced by **Multi-stage transistor amplifiers**.

In Multi-stage amplifiers, the output of first stage is coupled to the input of next stage using a coupling device. These coupling devices can usually be a capacitor or a transformer. This process of joining two amplifier stages using a coupling device can be called as **Cascading**.

The following figure shows a two-stage amplifier connected in cascade.



The overall gain is the product of voltage gain of individual stages.

$$AV = AV_1 \times AV_2 = \frac{V_2}{V_1} \times \frac{V_o}{V_2} = \frac{V_o}{V_1}$$

Where A_v = Overall gain, A_{v1} = Voltage gain of 1st stage, and A_{v2} = Voltage gain of 2nd stage.

If there is n number of stages, the product of voltage gains of those n stages will be the overall gain of that multistage amplifier circuit.

Purpose of coupling device

The basic purposes of a coupling device are

- To transfer the AC from the output of one stage to the input of next stage.
- To block the DC to pass from the output of one stage to the input of next stage, which means to isolate the DC conditions.

Types of Coupling

Joining one amplifier stage with the other in cascade, using coupling devices form a **Multi-stage amplifier circuit**. There are **four** basic methods of coupling, using these coupling devices such as resistors, capacitors, transformers etc. Let us have an idea about them.

Resistance-Capacitance Coupling

This is the mostly used method of coupling, formed using simple **resistor-capacitor** combination. The capacitor which allows AC and blocks DC is the main coupling element used here.

The coupling capacitor passes the AC from the output of one stage to the input of its next stage. While blocking the DC components from DC bias voltages to effect the next stage. Let us get into the details of this method of coupling in the coming chapters.

Impedance Coupling

The coupling network that uses **inductance** and **capacitance** as coupling elements can be called as Impedance coupling network.

In this impedance coupling method, the impedance of coupling coil depends on its inductance and signal frequency which is $j\omega L$. This method is not so popular and is seldom employed.

Transformer Coupling

The coupling method that uses a **transformer as the coupling** device can be called as Transformer coupling. There is no capacitor used in this method of coupling because the transformer itself conveys the AC component directly to the base of second stage.

The secondary winding of the transformer provides a base return path and hence there is no need of base resistance. This coupling is popular for its efficiency and its impedance matching and hence it is mostly used.

Direct Coupling

If the previous amplifier stage is connected to the next amplifier stage directly, it is called as **direct coupling**. The individual amplifier stage bias conditions are so designed that the stages can be directly connected without DC isolation.

The direct coupling method is mostly used when the load is connected in series, with the output terminal of the active circuit element. For example, head-phones, loud speakers etc.

Role of Capacitors in Amplifiers

Other than the coupling purpose, there are other purposes for which few capacitors are especially employed in amplifiers. To understand this, let us know about the role of capacitors in Amplifiers.

The Input Capacitor C_{in}

The input capacitor C_{in} present at the initial stage of the amplifier, couples AC signal to the base of the transistor. This capacitor C_{in} if not present, the signal source will be in parallel to resistor R_2 and the bias voltage of the transistor base will be changed.

Hence C_{in} allows, the AC signal from source to flow into input circuit, without affecting the bias conditions.

The Emitter By-pass Capacitor C_e

The emitter by-pass capacitor C_e is connected in parallel to the emitter resistor. It offers a low reactance path to the amplified AC signal.

In the absence of this capacitor, the voltage developed across R_E will feedback to the input side thereby reducing the output voltage. Thus in the presence of C_e the amplified AC will pass through this.

Coupling Capacitor C_c

The capacitor C_c is the coupling capacitor that connects two stages and prevents DC interference between the stages and controls the operating point from shifting. This is also called as **blocking capacitor** because it does not allow the DC voltage to pass through it.

In the absence of this capacitor, R_c will come in parallel with the resistance R_1 of the biasing network of the next stage and thereby changing the biasing conditions of the next stage.

Amplifier Consideration

For an amplifier circuit, the overall gain of the amplifier is an important consideration. To achieve maximum voltage gain, let us find the most suitable transistor configuration for cascading.

CC Amplifier

- Its voltage gain is less than unity.
- It is not suitable for intermediate stages.

CB Amplifier

- Its voltage gain is less than unity.
- Hence not suitable for cascading.

CE Amplifier

- Its voltage gain is greater than unity.
- Voltage gain is further increased by cascading.

The characteristics of CE amplifier are such that, this configuration is very suitable for cascading in amplifier circuits. Hence most of the amplifier circuits use CE configuration.

Two Stage CE-CE Cascade Amplifier

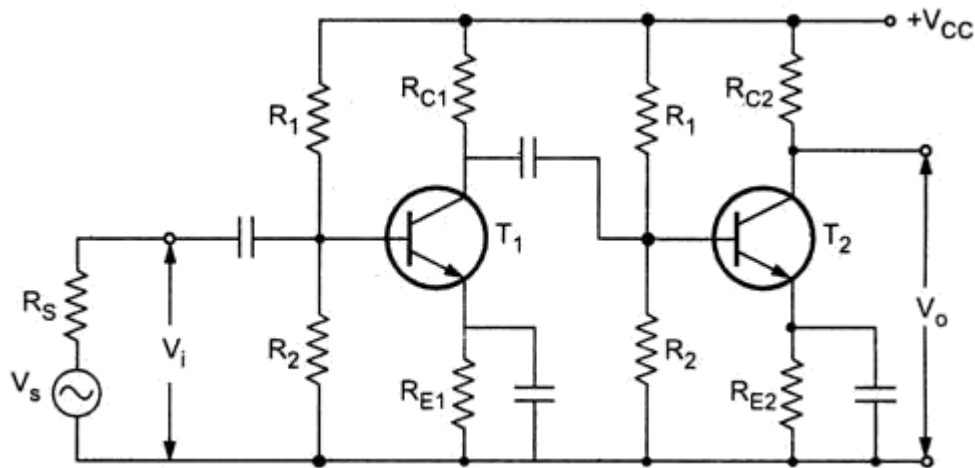

h-parameter equivalent circuit

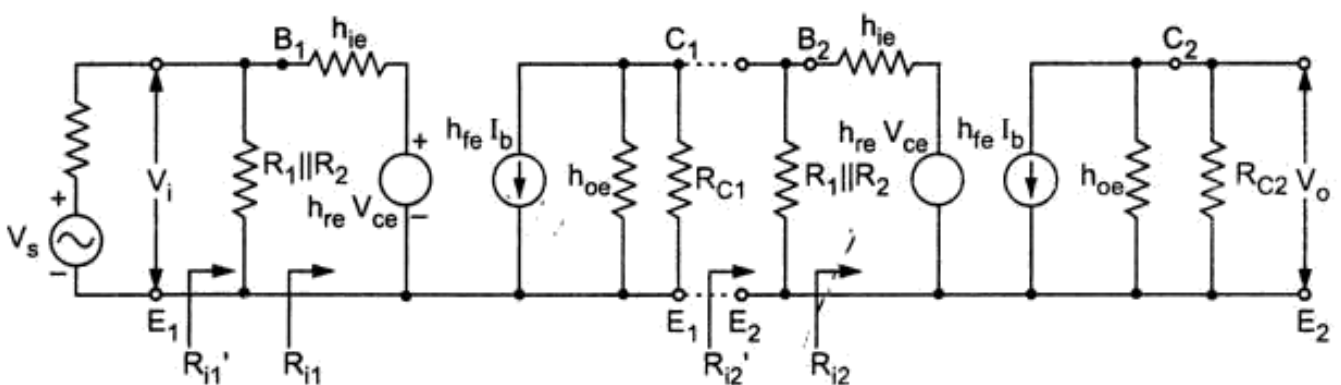

Cascode Amplifier

Cascode Amplifier

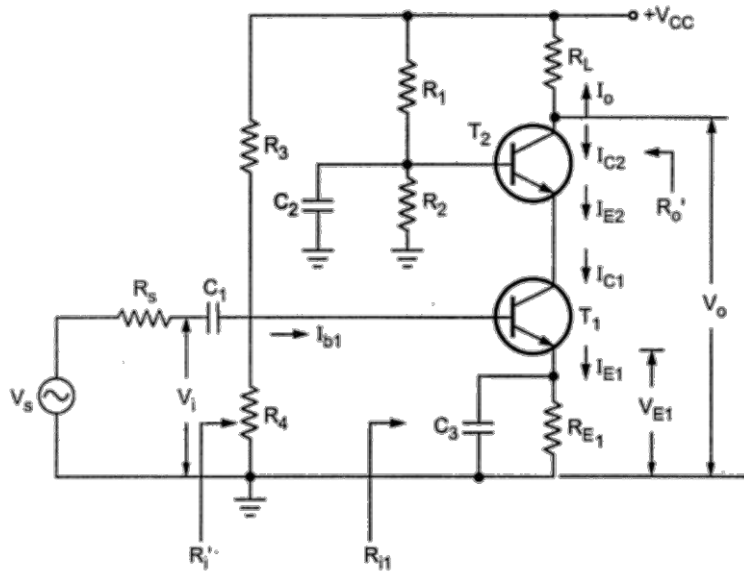

AC equivalent circuit

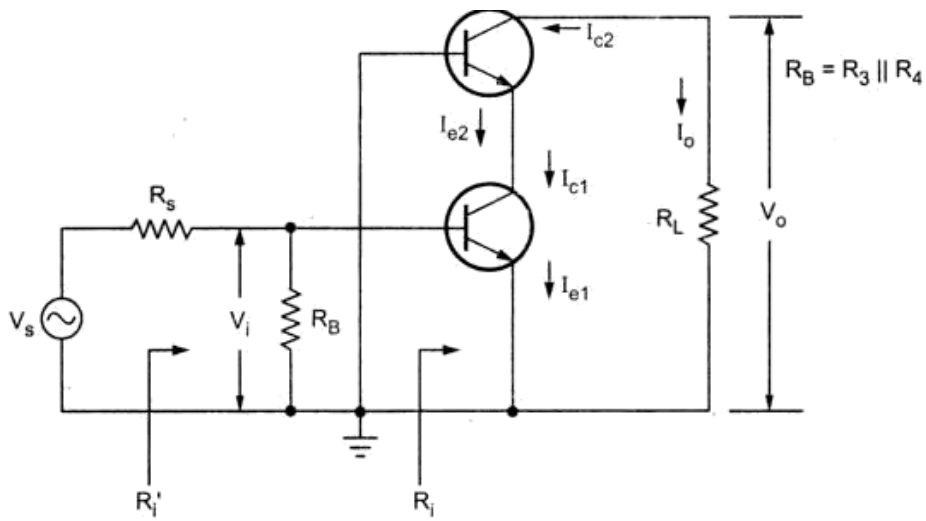

parameter equivalent circuit

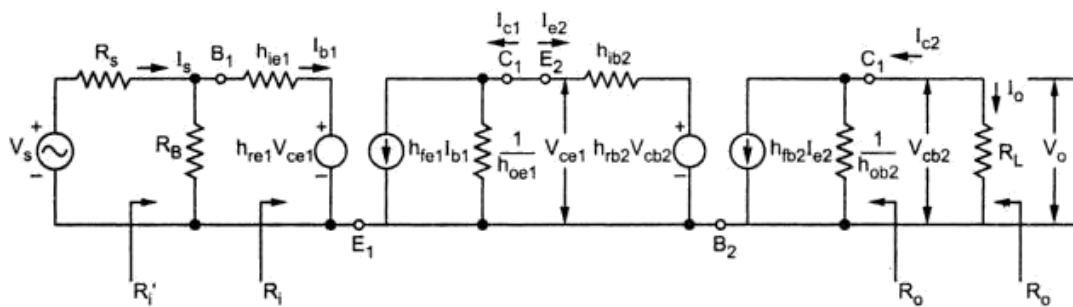

Darlington pair

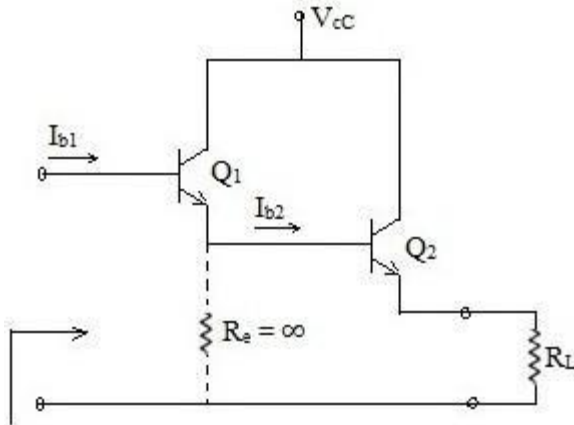

Darlington pair 1- Two emitter follower stages in cascade with infinite emitter resistance in the first stage constitute a Darlington circuit.

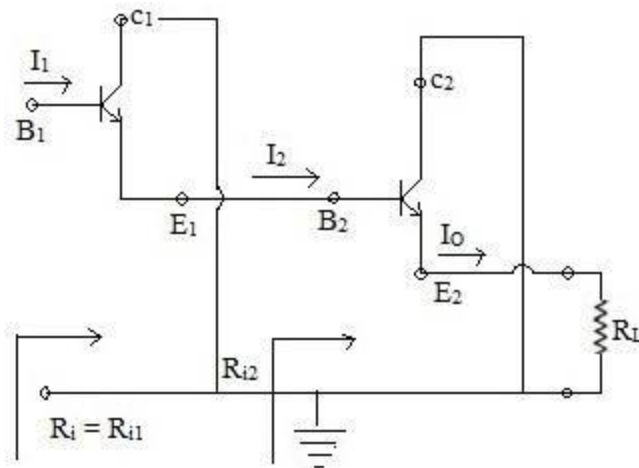

Second Stage

Let us assume , $h_{oe} R_L < 0.1$

Also $h_{fe} \gg 1$

$$A_{I_2} = \frac{I_o}{I_2} = 1 + h_{fe} \approx h_{fe} \text{ ----- (1)}$$

$$R_{i2} = h_{ie} + (1+h_{fe}) R_L \sim h_{ie} + h_{fe} R_L \text{ ----- (2)}$$

$$R_{L1} = R_{i2} = h_{fe} R_L \text{ ----- (3)}$$

First Stage

$h_{oe} R_{L1} = h_{oe} h_{fe} R_L < 0.1$. If this inequality is satisfied, then we can use simplified equivalent ckt in the first stage. Using exact solution

$$A_{I_1} = \frac{-h_{fe}}{1 + h_{oe} R_{L1}}$$

$$A_{I_1} = \frac{1 + h_{fe}}{1 + h_{oe} h_{fe} R_L} \text{ ----- (4)}$$

$$R_{i1} = h_{ie} + h_{rc} A_{I1} R_{L1}$$

$$= h_{ie} + \frac{h_{fe} h_{fe} R_L}{1 + h_{oe} h_{fe} R_L}$$

$$= h_{ie} + \frac{h_{fe}^2 R_L}{1 + h_{oe} h_{fe} R_L}$$

For emitter follower

$$R_i = h_{ie} + (1+h_{fe}) R_L$$

$$= h_{ie} + h_{fe} R_L$$

Overall current gain

$$A_i = A_1 A_2 = \frac{h_{fe}^2}{1+h_{oe} h_{fe} R_L}$$

Emitter follower, $A_v = \frac{1-h_{ie}}{R_L}$ ----- (1)

Darlington ckt, $A_v = A_{v1} A_{v2}$

$$= \frac{1-h_{ie2}}{R_{i2}} (2 + h_{oe} h_{fe} R_L) \text{----- (2)}$$

Effect of biasing network on the input resistance of emitter follower or Darlington ckt.

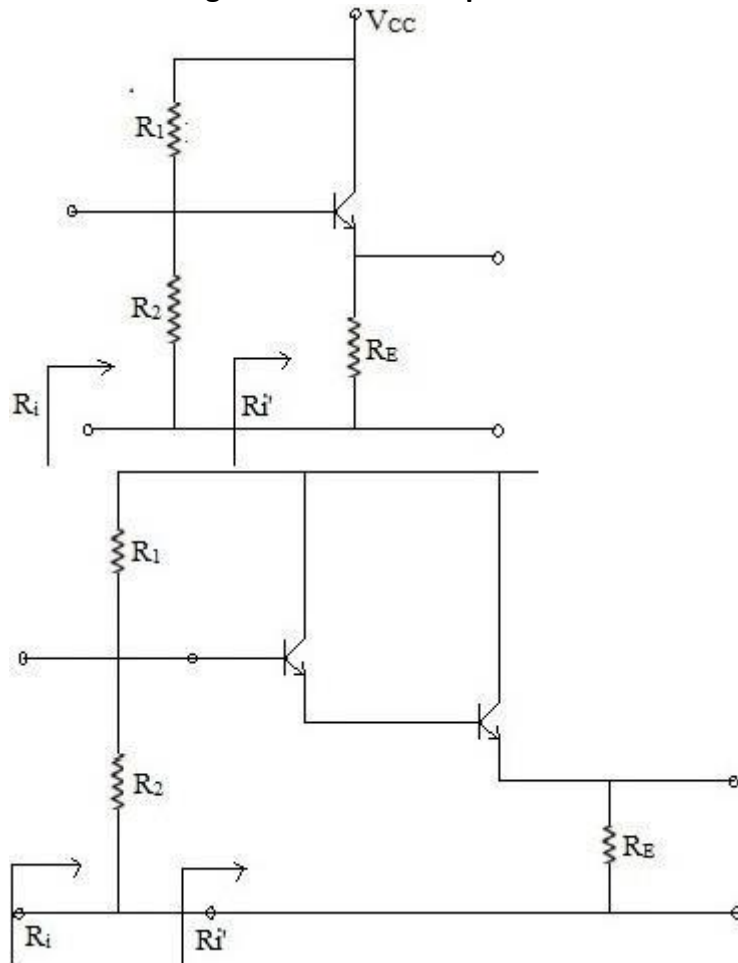

Effective input resistance $R_i = R_1 \parallel R_2 \parallel R_i'$ where R_i' is a large input resistance of emitter follower or Darlington ckt.

$$R_i = R_B \parallel R_i'$$

$$\sim R_B$$

Emitter follower with Boot Strap Biasing

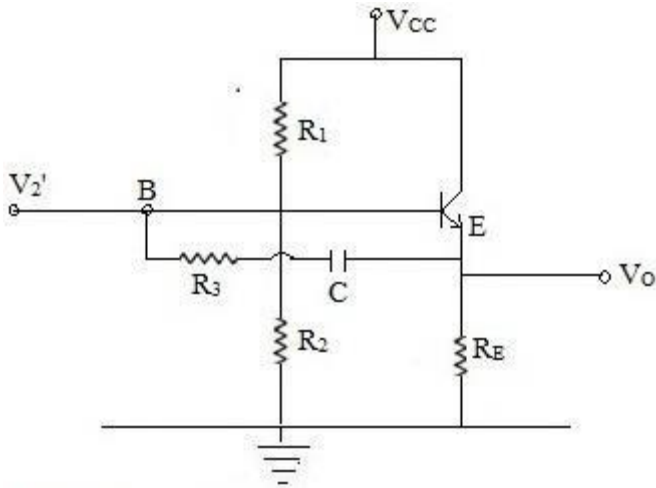

The reactance offered by the capacitor is very low for all frequencies.

$$A_V = \frac{V_o}{V_i}$$

$$\therefore V_o = A_V V_i \approx V_i$$

R_3 can be replaced by Miller's theorem

$$R_{3i} = \frac{R_3}{1 - A_V} = \infty$$

$$R_{3o} = \frac{R_3}{1 - 1/A_V} = \frac{R_3 A_V}{A_V - 1}$$

Effective output resistance

$$R_L = R_o \parallel R_{3o} \parallel R_B$$

$$\approx R_o$$

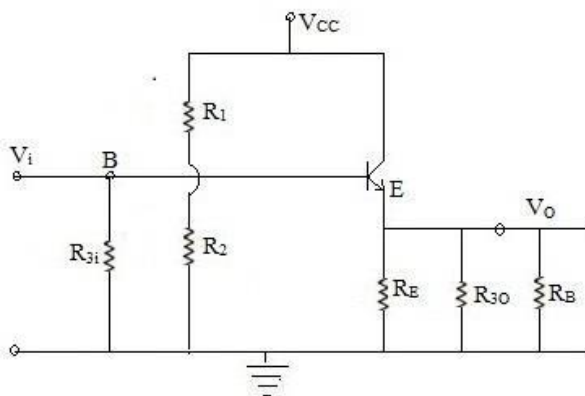

Coupling Schemes

Two-stage RC Coupled Amplifier

The resistance-capacitance coupling is, in short termed as RC coupling. This is the mostly used coupling technique in amplifiers.

Construction of a Two-stage RC Coupled Amplifier

The constructional details of a two-stage RC coupled transistor amplifier circuit are as follows. The two stage amplifier circuit has two transistors, connected in CE configuration and a common power supply V_{CC} is used. The potential divider network R_1 and R_2 and the resistor R_e form the biasing and stabilization network. The emitter by-pass capacitor C_e offers a low reactance path to the signal.

The resistor R_L is used as a load impedance. The input capacitor C_{in} present at the initial stage of the amplifier couples AC signal to the base of the transistor. The capacitor C_C is the coupling capacitor that connects two stages and prevents DC interference between the stages and controls the shift of operating point. The figure below shows the circuit diagram of RC coupled amplifier.

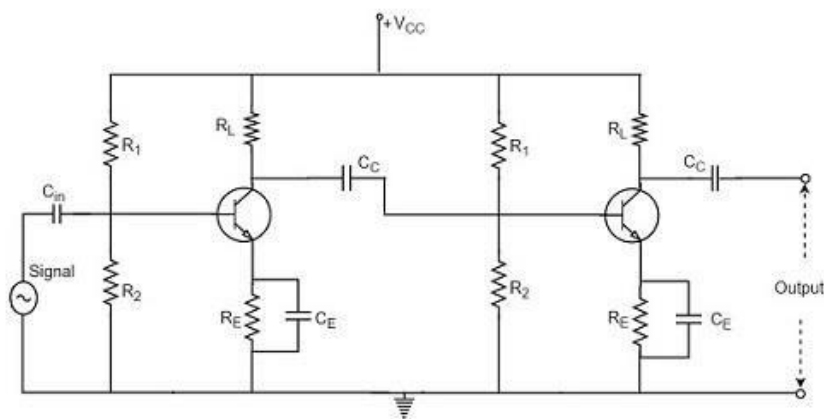

Operation of RC Coupled Amplifier

When an AC input signal is applied to the base of first transistor, it gets amplified and appears at the collector load R_L which is then passed through the coupling capacitor C_C to the next stage. This becomes the input of the next stage, whose amplified output again appears across its collector load. Thus the signal is amplified in stage by stage action.

The important point that has to be noted here is that the total gain is less than the product of the gains of individual stages. This is because when a second stage is made to follow the first stage, the **effective load resistance** of the first stage is reduced due to the shunting

effect of the input resistance of the second stage. Hence, in a multistage amplifier, only the gain of the last stage remains unchanged.

As we consider a two stage amplifier here, the output phase is same as input. Because the phase reversal is done two times by the two stage CE configured amplifier circuit.

Frequency Response of RC Coupled Amplifier

Frequency response curve is a graph that indicates the relationship between voltage gain and function of frequency. The frequency response of a RC coupled amplifier is as shown in the following graph.

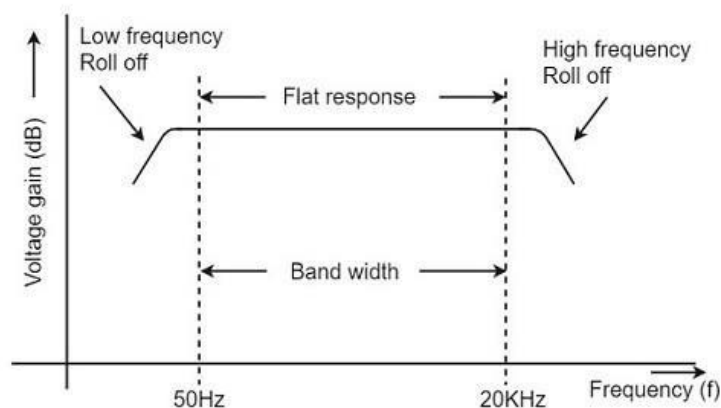

From the above graph, it is understood that the frequency rolls off or decreases for the frequencies below 50Hz and for the frequencies above 20 KHz. whereas the voltage gain for the range of frequencies between 50Hz and 20 KHz is constant.

We know that,

$$X_C = 1/2\pi f_c$$

It means that the capacitive reactance is inversely proportional to the frequency.

At Low frequencies (i.e. below 50 Hz)

The capacitive reactance is inversely proportional to the frequency. At low frequencies, the reactance is quite high. The reactance of input capacitor C_{in} and the coupling capacitor C_C are so high that only small part of the input signal is allowed. The reactance of the emitter by pass capacitor C_E is also very high during low frequencies. Hence it cannot shunt the emitter resistance effectively. With all these factors, the voltage gain rolls off at low frequencies.

At High frequencies (i.e. above 20 KHz): Again considering the same point, we know that the capacitive reactance is low at high frequencies. So, a capacitor behaves as a short

circuit, at high frequencies. As a result of this, the loading effect of the next stage increases, which reduces the voltage gain. Along with this, as the capacitance of emitter diode decreases, it increases the base current of the transistor due to which the current gain (β) reduces. Hence the voltage gain rolls off at high frequencies.

At Mid-frequencies (i.e. 50 Hz to 20 KHz)

The voltage gain of the capacitors is maintained constant in this range of frequencies, as shown in figure. If the frequency increases, the reactance of the capacitor C_C decreases which tends to increase the gain. But this lower capacitance reactive increases the loading effect of the next stage by which there is a reduction in gain.

Due to these two factors, the gain is maintained constant.

Advantages of RCCoupledAmplifier

The following are the advantages of RC coupled amplifier.

- The frequency response of RC amplifier provides constant gain over a wide frequency range, hence most suitable for audio applications.
- The circuit is simple and has lower cost because it employs resistors and capacitors which are cheap.
- It becomes more compact with the upgrading technology.

Disadvantages of RCCoupledAmplifier

The following are the disadvantages of RC coupled amplifier.

- The voltage and power gain are low because of the effective load resistance.
- They become noisy with age.
- Due to poor impedance matching, power transfer will be low.

Applications of RCCoupledAmplifier

The following are the applications of RC coupled amplifier.

- They have excellent audio fidelity over a wide range of frequency.
- Widely used as Voltage amplifiers
- Due to poor impedance matching, RC coupling is rarely used in the final stages.

We have observed that the main drawback of RC coupled amplifier is that the effective load resistance gets reduced. This is because, the input impedance of an amplifier is low, while its output impedance is high.

When they are coupled to make a multistage amplifier, the high output impedance of one stage comes in parallel with the low input impedance of next stage. Hence, effective load resistance is decreased. This problem can be overcome by a **transformer coupled amplifier**.

In a transformer-coupled amplifier, the stages of amplifier are coupled using a transformer. Let us go into the constructional and operational details of a transformer coupled amplifier.

Construction of Transformer Coupled Amplifier

The amplifier circuit in which, the previous stage is connected to the next stage using a coupling transformer, is called as Transformer coupled amplifier.

The coupling transformer T_1 is used to feed the output of 1st stage to the input of 2nd stage. The collector load is replaced by the primary winding of the transformer. The secondary winding is connected between the potential divider and the base of 2nd stage, which provides the input to the 2nd stage. Instead of coupling capacitor like in RC coupled amplifier, a transformer is used for coupling any two stages, in the transformer coupled amplifier circuit.

The figure below shows the circuit diagram of transformer coupled amplifier.

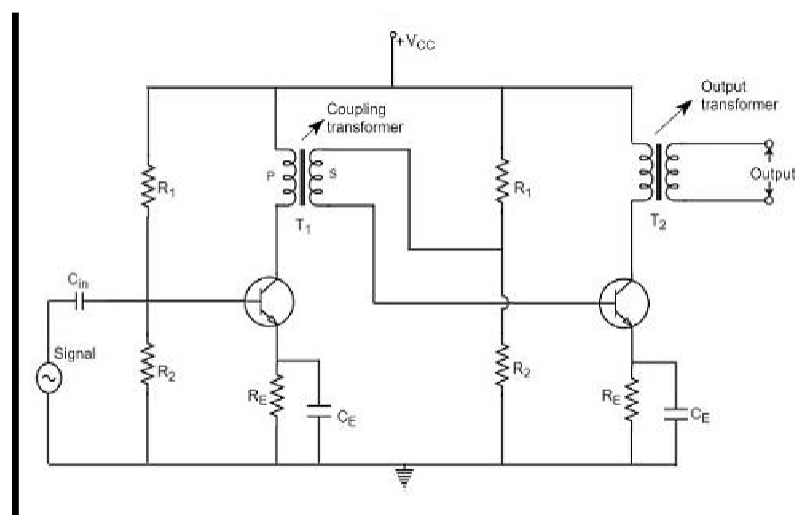

The potential divider network R_1 and R_2 and the resistor R_e together form the biasing and stabilization network. The emitter by-pass capacitor C_e offers a low reactance path to the signal. The resistor R_L is used as a load impedance. The input capacitor C_{in} present at the initial stage of the amplifier couples AC signal to the base of the transistor. The capacitor

C_c is the coupling capacitor that connects two stages and prevents DC interference between the stages and controls the shift of operating point.

Operation of Transformer Coupled Amplifier

When an AC signal is applied to the input of the base of the first transistor then it gets amplified by the transistor and appears at the collector to which the primary of the transformer is connected.

The transformer which is used as a coupling device in this circuit has the property of impedance changing, which means the low resistance of a stage (or load) can be reflected as a high load resistance to the previous stage. Hence the voltage at the primary is transferred according to the turns ratio of the secondary winding of the transformer.

This transformer coupling provides good impedance matching between the stages of amplifier. The transformer coupled amplifier is generally used for power amplification.

Frequency Response of Transformer Coupled Amplifier

The figure below shows the frequency response of a transformer coupled amplifier. The gain of the amplifier is constant only for a small range of frequencies. The output voltage is equal to the collector current multiplied by the reactance of primary.

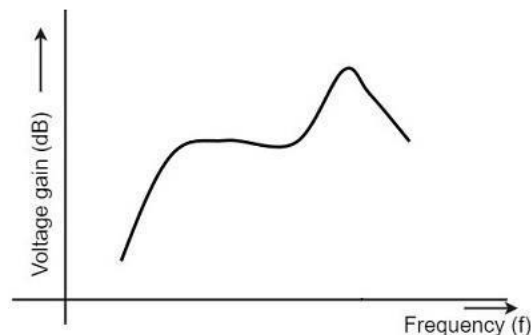

At low frequencies, the reactance of primary begins to fall, resulting in decreased gain. At high frequencies, the capacitance between turns of windings acts as a bypass condenser to reduce the output voltage and hence gain.

So, the amplification of audio signals will not be proportionate and some distortion will also get introduced, which is called as **Frequency distortion**.

Advantages of Transformer Coupled Amplifier

- An excellent impedance matching is provided.
- Gain achieved is higher.
- There will be no power loss in collector and base resistors.
- Efficient in operation.

Disadvantages of Transformer Coupled Amplifier

The following are the disadvantages of a transformer coupled amplifier –

- Though the gain is high, it varies considerably with frequency. Hence a poor frequency response.
- Frequency distortion is higher.
- Transformers tend to produce hum noise.
- Transformers are bulky and costly.

Applications

The following are the applications of a transformer coupled amplifier –

- Mostly used for impedance matching purposes.
- Used for Power amplification.
- Used in applications where maximum power transfer is needed.

The other type of coupling amplifier is the direct coupled amplifier, which is especially used to amplify lower frequencies, such as amplifying photo-electric current or thermo-couple current or so.

Direct Coupled Amplifier

As no coupling devices are used, the coupling of the amplifier stages is done directly and hence called as **Direct coupled amplifier**.

Construction

The figure below indicates the three stage direct coupled transistor amplifier. The output of first stage transistor T_1 is connected to the input of second stage transistor T_2 .

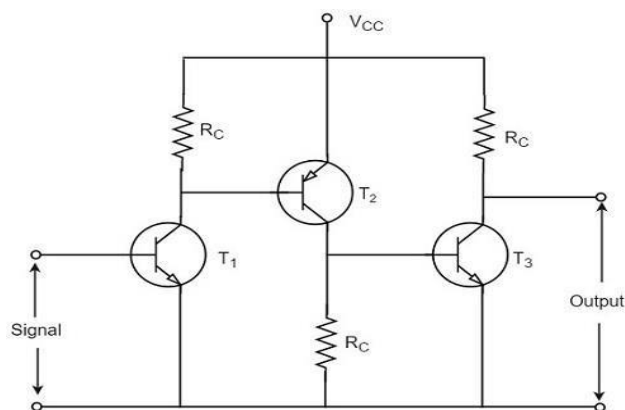

The transistor in the first stage will be an NPN transistor, while the transistor in the next stage will be a PNP transistor and so on. This is because; the variations in one transistor tend to cancel the variations in the other. The rise in the collector current and the variation in β of one transistor gets cancelled by the decrease in the other.

Operation

The input signal when applied at the base of transistor T_1 , it gets amplified due to the transistor action and the amplified output appears at the collector resistor R_c of transistor T_1 . This output is applied to the base of transistor T_2 which further amplifies the signal. In this way, a signal is amplified in a direct coupled amplifier circuit.

Advantages

The advantages of direct coupled amplifier are as follows.

- The circuit arrangement is simple because of minimum use of resistors.
- The circuit is of low cost because of the absence of expensive coupling devices.

Disadvantages

The disadvantages of direct coupled amplifier are as follows.

- It cannot be used for amplifying high frequencies.
- The operating point is shifted due to temperature variations.

Applications

- Low frequency amplifications.
- Low current amplifications.

Comparisons

S.No	Particular	RC Coupling	Transformer	Direct Coupling
1	Frequency	Excellent in audio	Poor	Best
2	Cost	Less	More	Least
3	Space and	Less	More	Least
4	Impedance	Not good	Excellent	Good
5	Use	For voltage	For Power	For amplifying

UNIT-II

BJT Amplifiers- Frequency Response

Under reverse bias condition the capacitance at the junction is called transition or space charge capacitance.

Under forward bias condition the capacitance is called diffusion or storage capacitance.

At high frequencies, BJT cannot be analysed by h-parameters.

Giacolletto model - hybrid π equivalent ckt

Desirable fractures of hybrid π equivalent circuit (ckt)

- (1) The value of components in the equivalent ckt. are independent of frequencies.
- (2) The values of all the resistive components in the equivalent ckt. can be determined from the known or Specified values of h-parameters at low frequencies.
- (3) The results obtained by using this equivalent ckt. Agrees with the experimental result.

The components of the equivalent ckt. exist in the form of π hence the name.



For small signal behaviour the transistor at its input port behaves as a resistor.

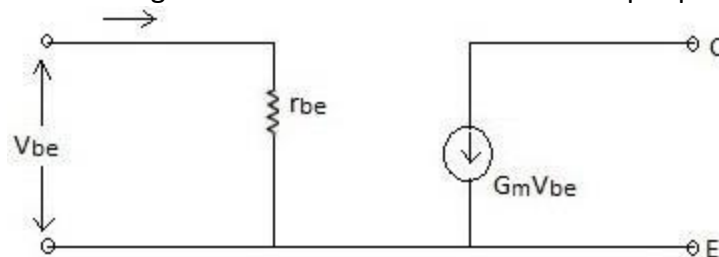

The output port is a dependent current source.

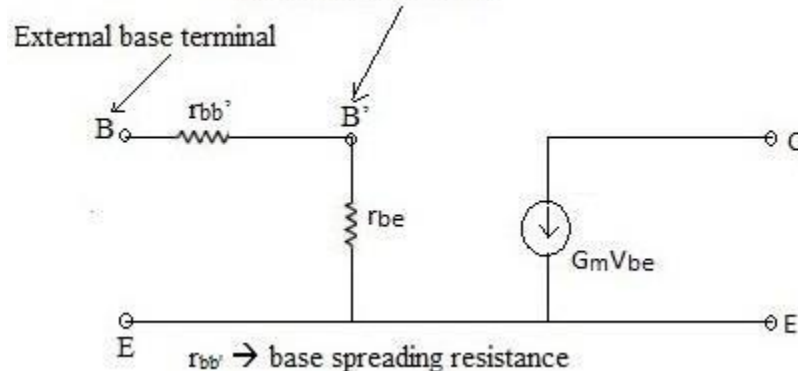
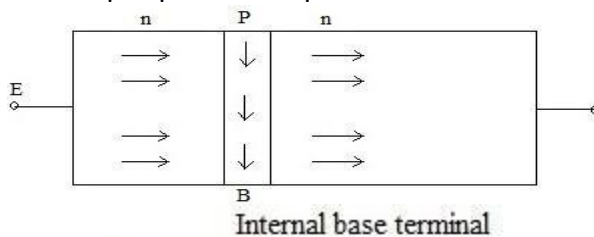

Because the base (B) is lightly doped all the depletion region lies entirely in the Base region. So, when the collector.

voltage is increased the depletion region in the base increases.

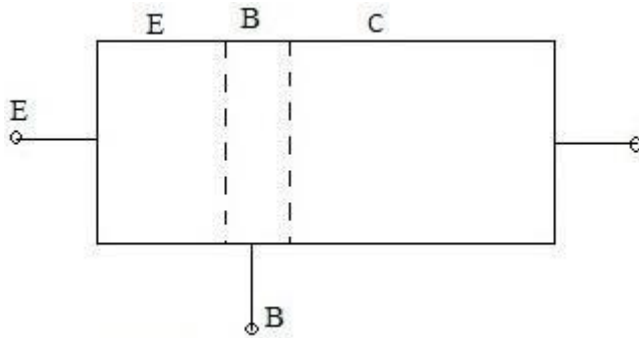

$r_{ce} \rightarrow$ This resistance is added to compensate for the change in I_c due to change in V_{CE} .

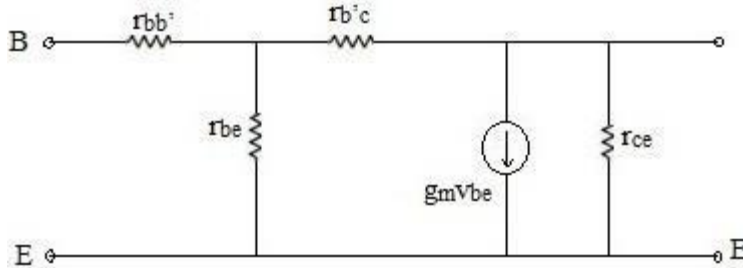

The High frequency model parameters of a BJT in terms of low frequency hybrid parameters is given below

Transconductance $g_m = I_c / V_t$

Internal Base node to emitter resistance $r_{b'e} = h_{fe} / g_m = (h_{fe} * V_t) / I_c$

Internal Base node to collector resistance $r_{b'c} = (h_{re} * r_{b'e}) / (1 - h_{re})$ assuming $h_{re} \ll 1$ it reduces to $r_{b'c} = (h_{re} * r_{b'e})$

Base spreading resistance $r_{bb'} = h_{ie} - r_{b'e} = h_{ie} - (h_{fe} * V_t) / I_c$

Collector to emitter resistance $r_{ce} = 1 / (h_{oe} - (1 + h_{fe}) / r_{b'e})$

The C_E short circuit current gain (A_i)

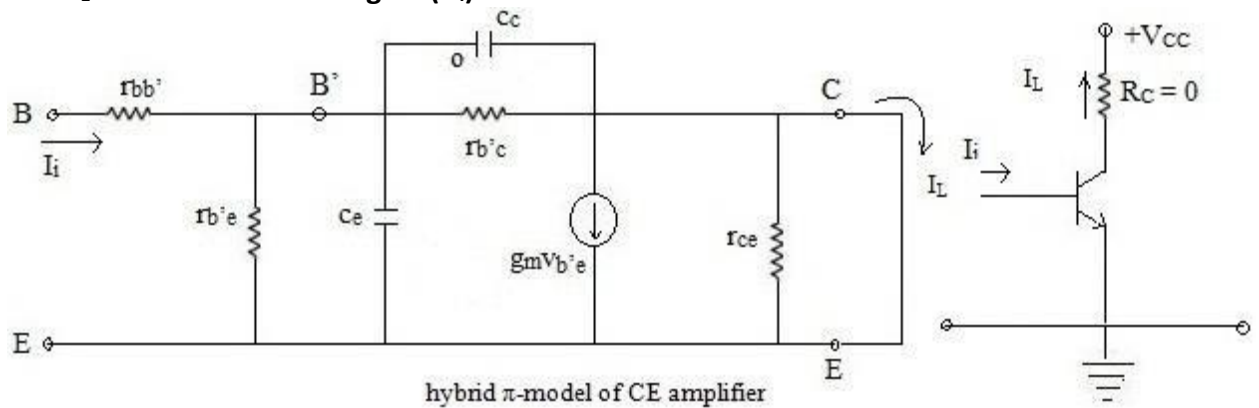

$$g_m = \frac{|I_c|}{V_T}, \quad r_{b'e} = \frac{h_{fe}}{g_m}, \quad r_{b'c} = \frac{r_{b'e}}{h_{re}}$$

$$\frac{1}{r_{ce}} \cong h_{oe} - \frac{(1 + h_{fe})}{r_{b'e}}, \quad C_C = 3pF, \quad C_e = \frac{g_m}{2\pi F_T}$$

$$A_i = \frac{I_L}{I_i}$$

(1) C_e is in shunt with short circuit and behaves as open circuit and hence is removed from the equivalent circuit.

(2) $r_{b'e} \parallel r_{b'c} \parallel r_{b'e}$

$$C_C \parallel C_e = C_C + C_e$$

(3) Current delivered directly to the output from input through $r_{b'c}$ & C_C is negligibly small compared to dependent current source $g_m V_{b'e}$

Under these assumptions the simplified hybrid model of C_E amplifier.

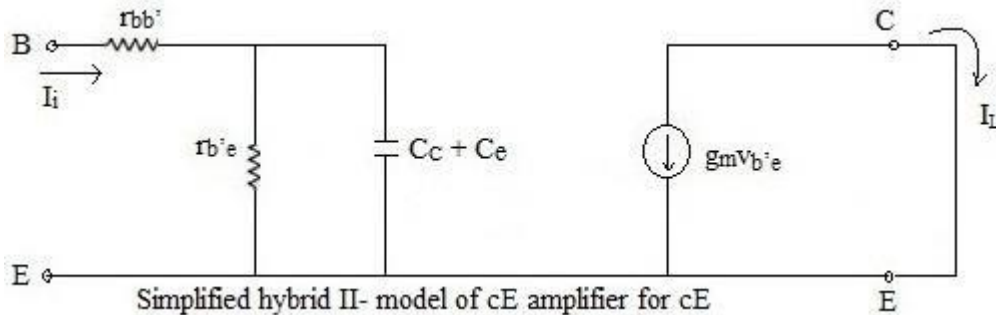

$$A_i = \frac{I_C}{I_i} = \frac{-g_m I_i}{\frac{1}{r_{b'e}} + j\omega(C_C + C_e)}$$

$$\frac{I_C}{I_i} = \frac{-g_m r_{b'e}}{1 + j\omega(C_C + C_e)r_{b'e}}$$

$$= \frac{-g_m r_{b'e}}{1 + jf / \frac{1}{2\pi r_{b'e}(C_C + C_e)}}$$

$$A_i = \frac{-h_{fe}}{1 + jf/f_B} \text{ ----- (1)}$$

$$\text{where } f_B = \frac{1}{2\pi r_{b'e}(C_C + C_e)} \text{ ----- (2)}$$

At $f = 0$, $A_i = -h_{fe}$

At $f = f_B$, $A_i = \frac{-h_{fe}}{1+j}$

$$\text{Or } |A_i| = \frac{-h_{fe}}{\sqrt{2}} = \frac{\text{max}^{\text{current gain}}}{\sqrt{2}}$$

Thus at $f = f_B$, the short ckt. current gain is $\frac{1}{\sqrt{2}}$ times the $\text{max}^{\text{short ckt. current gain}}$ available at low frequency.

$\frac{1}{\sqrt{2}}$ corresponds to -3dB and hence f_B is called 3dB frequency and the frequency range $0 - f_B$ is called bandwidth of the amplifier.

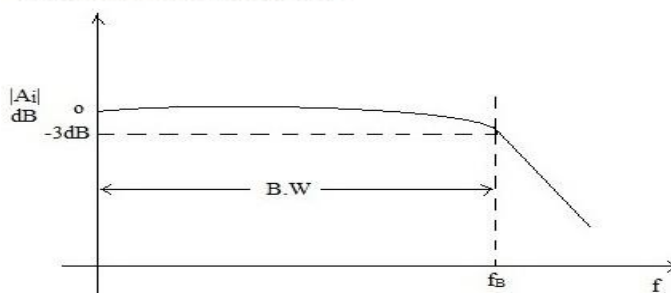

The parameter f_T : The frequency at which the magnitude short ckt. current gain of C_E amplifier reduces to unity is defined as frequency f_T

$f_T \rightarrow$ Gain bandwidth product of an amplifier.

$$A_i = \frac{-h_{fe}}{1 + jf/f_B}$$

$$|A_i| = \frac{h_{fe}}{[1 + (f/f_B)^2]^{\frac{1}{2}}}$$

\therefore From above

$$1 = \frac{h_{fe}}{[1 + (f_T/f_B)^2]^{\frac{1}{2}}}$$

$$[1 + (f_T/f_B)^2]^{\frac{1}{2}} = h_{fe}$$

$$f_T = f_B \sqrt{h_{fe}^2 - 1}$$

$$\therefore h_{fe}^2 \gg 1$$

$$\therefore f_T = f_B \sqrt{h_{fe}^2}$$

$$\therefore f_T = f_B h_{fe}$$

$$\text{Also, } f_T = \frac{h_{fe}}{2\pi r_{b'e}(C_C + C_e)}$$

$$f_T = \frac{g_m}{2\pi(C_C + C_e)}$$

$$C_C + C_e = \frac{g_m}{2\pi f_T}$$

$$\therefore C_e = \frac{g_m}{2\pi f_T} - C_C$$

$$\therefore g_m/2\pi f_T \gg C_C$$

$$\boxed{C_e = \frac{g_m}{2\pi f_T}}$$

$$\frac{A_i}{h_{fe}} = \frac{1}{[1 + (f/f_B)^2]^{\frac{1}{2}}}$$

$$20 \log_{10} \left| \frac{A_i}{h_{fe}} \right| = 20 \log_{10} \frac{1}{[1 + (f/f_B)^2]^{\frac{1}{2}}}$$

$$= -10 \log_{10} [1 + (f/f_B)^2]$$

$$|A_i| = \text{at } f = f_T = -20 \log_{10} (f/f_B)$$

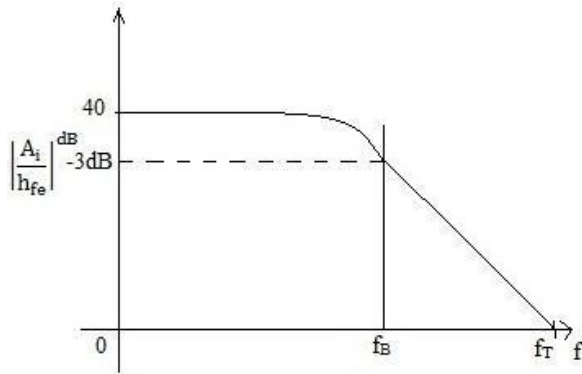

Current gain of C_E amplifier with Resistive Load

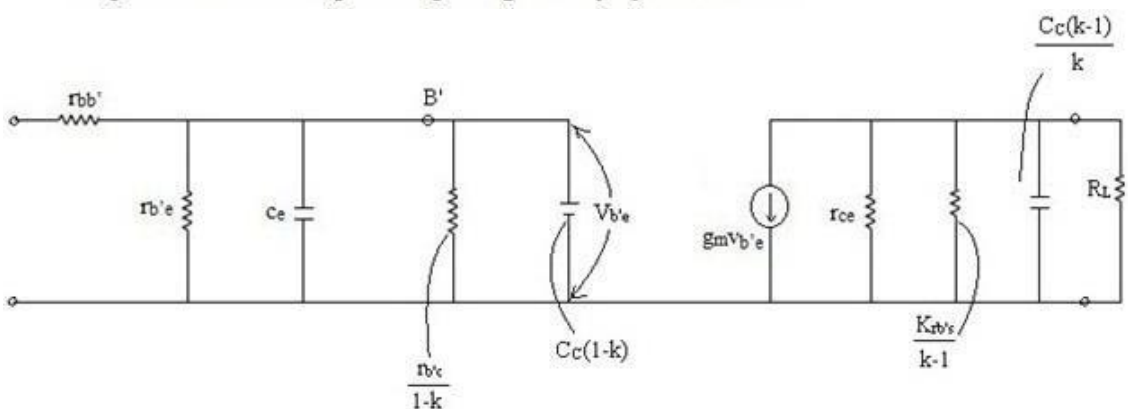
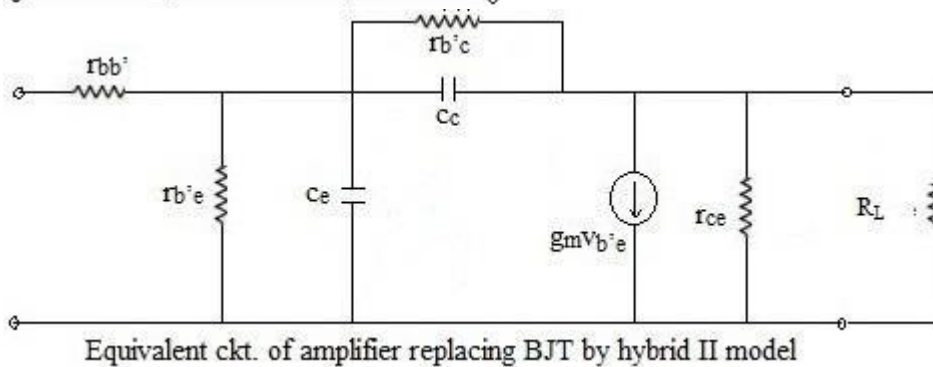
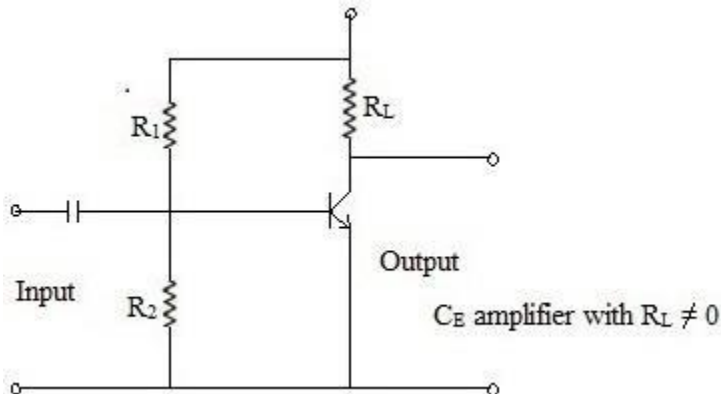

Assumptions :

1) Both input and output loop contain R_c ckt. the R_c product of input loop is larger than that of output loop and

determines the bandwidth of (3dB frequency) of the amplifier. Consequently the

capacitance $\frac{C_c K}{K-1}$ is omitted or removed from equivalent ckt.

(2) For practical amplifier $R_L < 2K\Omega$

$$\frac{K}{K-1} r_{b'e} \approx r_{b'e} \approx 4M\Omega$$

$$r_{ce} = 80K$$

$$\frac{K}{K-1} || r_{ce} || R_L \cong R_L$$

$$(3) V_{ce} = -g_m V_{b'e} R_L$$

$$\frac{V_{ce}}{V_{b'e}} = K = -g_m R_L$$

Typical value of $g_m = 50mA/V$ & $R_L = 2K\Omega$. Putting these value $K = -100$.

In the input loop

Typical value of $r_{b'e} \cong 1K$

$$r_{b'e} || \frac{r_{b'e}}{1-K} \approx r_{b'e}$$

$\frac{r_{b'e}}{1-K}$ is omitted from the input loop.

$$(4) C = C_e + C_c (1-K)$$

$$= C_e + C_c (1 + g_m)$$

Final equivalent ckt.

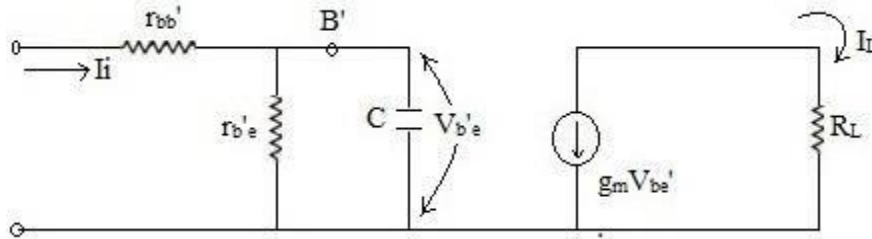

$$A_i' = \frac{I_L}{I_i} = -g_m V_{b'e}$$

$$= \frac{-g_m I_i}{\frac{1}{r_{b'e}} + j\omega C}$$

$$\therefore \frac{I_L}{I_i} = \frac{-g_m r_{b'e}}{1 + j\omega C r_{b'e}} = \frac{-h_{fe}}{1 + jf / \frac{1}{2\pi r_{b'e} C}}$$

$$\therefore A_i' = \frac{-h_{fe}}{1 + jf/f_H} \text{-----(1)}$$

$$\text{Where } f_H = \frac{1}{2\pi r_{b'e} C} \text{-----(2)}$$

$$\text{At } f = 0, \quad A_i = -h_{fe}$$

$$\text{at } f = f_H, \quad |A_i| = \frac{h_{fe}}{\sqrt{2}}$$

$$f_B = \frac{1}{2\pi r_{b'e} (C_e + C_c)}$$

Current gain of C_E amplifier taking source resistance into account

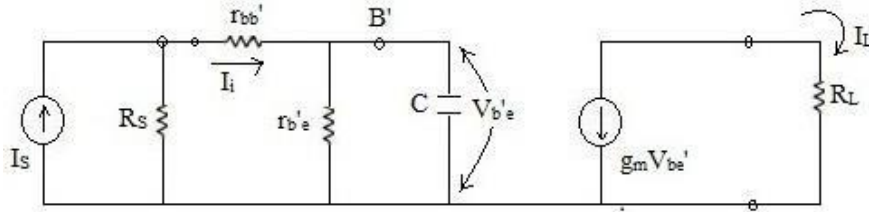

$$A_{I_S} = \frac{I_L}{I_S} = \frac{I_L'}{I_L'} * \frac{I_i}{I_S} = A_I * \frac{I_i}{I_S} \text{----- (1)}$$

$$A_I = \frac{-g_m r_{be'}}{1 + j\omega r_{be'} C} \text{----- (2)}$$

$$\frac{I_i}{I_S} = \frac{R_S}{r_{bb'} + R_S' + r_{be'} \parallel \frac{1}{j\omega C}}$$

Where $R_S' = r_{bb'} + R_S$

$$\frac{R_S}{R_S' + r_{be'} \parallel \frac{1}{j\omega C}}$$

$$\frac{I_i}{I_S} = \frac{R_S}{R_S' + \frac{r_{be'}}{1 + j\omega r_{be'} C}}$$

$$\frac{I_i}{I_S} = \frac{R_S(1 + j\omega r_{be'} C)}{r_{be'} + R_S'(1 + j\omega r_{be'} C)} \text{----- (3)}$$

$$A_{I_S} = (1) * (2)$$

$$= \frac{-g_m r_{be'} R_S}{r_{be'} + R_S'(1 + j\omega r_{be'} C)}$$

$$A_{I_S} = \frac{-g_m r_{be'} R_S}{r_{be'} + R_S' + j\omega r_{be'} R_S' C}$$

For $f = 0$, $j\omega C$

$$A_{I_{S0}} = \frac{-g_m R_S G_S'}{g_{b'e} + G_S'}$$

Also $= -g_m R_S$ where $g_{b'e} \ll G_S$

From (4)

$$A_{iS} = \frac{-g_m R_S G'_S / g_{b'e} + G'_S}{1 + j\omega C * \frac{1}{G'_S + g_{b'e}}}$$

$$f_H = \frac{1}{2\pi RC}$$

$$A_{iS} = \frac{A_{iS0}}{1 + j2\pi f c R}$$

$$\text{Where } R = \frac{1}{G'_S + g_{b'e}} \approx \frac{1}{G'_S} = R_S + r_{bb'}$$

$$C = C_e + C_C (1 + g_m R_L)$$

$$A_{iS} = \frac{A_{iS0}}{1 + jf/f_H}$$

So, to summarize

$$(i) R_L = 0 \quad A_i = \frac{-g_m r_{b'e}}{1 + jf/f_B} \text{-----(1)}$$

$$\text{Where, } f_B = \frac{1}{2\pi r_{b'e} (C_e + C_C)} \text{-----(2)}$$

$$R_L \neq 0 \quad A_i = \frac{-g_m r_{b'e}}{1 + jf/f_B} \text{-----(3)}$$

$$\text{Where, } f_H = \frac{1}{2\pi r_{b'e} C} \text{-----(4)}$$

$$C = C_e + C_C (1 + g_m R_L) \text{-----(5)}$$

(b) Taking source resistance into account

$$A_{iS} = \frac{-g_m R_S G'_S}{G'_S + g_{b'e} + j\omega C} = \frac{-g_m R_S G'_S / (G'_S + g_{b'e})}{1 + jf/f_H} \text{-----(6)}$$

$$f_H = \frac{1}{2\pi RC} \text{-----(7)}$$

$$R = \frac{1}{G'_S + g_{b'e}} \approx \frac{1}{G'_S} = R'_S = R_S + r_{bb'} \text{-----(8)}$$

$$C = C_e + C_C (1 + g_m R_L) \text{-----(9)}$$

Voltage gain taking source resistance into consideration

$$A_{VS} = A_{iS} \frac{R_L}{R_S} = \frac{-g_m R_S G'_S}{G'_S + g_{b'e} + j\omega C} * \frac{R_L}{R_S} = \frac{-g_m R_L G'_S}{G'_S + g_{b'e} + j\omega C} = \frac{-g_m R_L G'_S / (G'_S + g_{b'e})}{1 + j\omega \frac{C}{G'_S + g_{b'e}}}$$

$$\frac{-g_m R_L G'_S / G'_S + g_{b'e}}{1 + j2\pi f RC} = \frac{-g_m R_L G'_S / G'_S + g_{b'e}}{1 + jf/f_H} \quad \text{where } f_H = \frac{1}{2\pi RC}$$

$$R = R_S + r_{bb'} \quad C = C_e + C_C (1 + g_m R_L)$$

$$AV_{SO} = AV_S = \frac{-g_m R_L G'_S}{G'_S + g_{b'e}} = -g_m R_L \quad [\because G'_S \gg g_{b'e}]$$

Where $f = 0$

$$AV_{SO} = -g_m R_S$$

$$f_H = \frac{1}{2\pi RC} = \frac{1}{2\pi R\{C_e + C_C(1 + g_m R_L)\}}$$

$$\text{For } R_L = 0 \quad f_H = \frac{1}{2\pi R(C_e + C_C)} = \frac{f_T}{g_m R}$$

$$\therefore f_H = \frac{f_T}{g_m R} \quad \left[\because f_T = \frac{g_m}{2\pi(C_e + C_C)} \right]$$

Voltage Gain Bandwidth Product

$$|AV_{SO} * f_H| = g_m R_L * \frac{1}{2\pi RC} = \frac{g_m}{2\pi C} * \frac{R_L}{R} = \frac{g_m}{2\pi\{C_e + C_C(1 + g_m R_L)\}} * \frac{R_L}{(R_S + r_{bb'})}$$

$$\frac{g_m}{2\pi(C_e + C_C) + 2\pi C_C g_m R_L} * \frac{R_L}{R_S + r_{bb'}} = \frac{g_m / (C_e + C_C) 2\pi}{\frac{1 + 2\pi g_m C_C R_L}{2\pi C_C + C_e}} * \frac{R_L}{R_S + r_{bb'}}$$

$$\frac{f_T R_L}{(1 + 2\pi f_T C_C R_L)(R_S + r_{bb'})}$$

Problem - $f_H = 50 * 10^6 \text{ Hz}$, $R_L = 500 \Omega$, $h_{fe} = 100$, $g_m = 100 \text{ mA/V}$, $r_{bb'} = 100 \Omega$, $C_C = 1 \text{ PF}$, $f_T = 400 \text{ MHz}$, find $R_S = ?$

$$f_H = \frac{1}{2\pi RC} \text{ ----- (1)}$$

$$R = \frac{1}{G'_S + g_{b'e}} = \frac{1}{\frac{1}{R_S + r_{bb'}} + \frac{1}{r_{b'e}}} \text{ ----- (2)}$$

$$r_{b'e} = \frac{h_{fe}}{g_m} = 1000 \Omega \text{ ----- (3)}$$

$$C = C_e + C_C(1 + g_m R_L)$$

$$= \frac{g_m}{2\pi f_T} + C_C(1 + g_m R_L) = 90 * 10^{-12} \text{ ----- (4)}$$

$$R = \frac{1}{2\pi C f_H}$$

$$R_S = 449 \Omega$$

Bandwidth of a multistage amplifier

The range of frequencies which are amplified without much variation in gain is called bandwidth of amplifiers. Human ears are insensitive to the variation of power gain of about 3dB. Hence, frequency range from lower 3dB to upper 3dB is considered as bandwidth of single stage amplifier. Bandwidth of single stage amplifier.

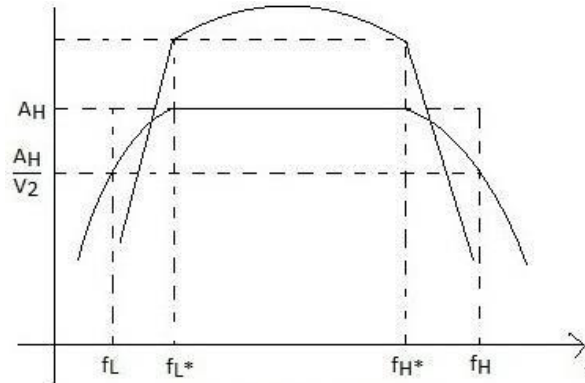

Amplifier response of an amplifier
Bandwidth (BW) = $f_H - f_L \approx f_H$

Lower 3dB frequency of multistage amplifier

The lower 3db frequency of n identical cascaded stages as $f_L(n)$. It is the frequency for which the overall gain falls to $\frac{1}{\sqrt{2}}$ (3 db) of its midband value.

$$\left[\frac{1}{\sqrt{1 + \left(\frac{f_L}{f_L(n)} \right)^2}} \right]^n = \frac{1}{\sqrt{2}}$$

$$\left[\sqrt{1 + \left(\frac{f_L}{f_L(n)} \right)^2} \right]^n = \sqrt{2}$$

Squaring on both sides we get

$$\left[1 + \left(\frac{f_L}{f_L(n)} \right)^2 \right]^n = 2$$

Taking n^{th} root on both sides

$$1 + \left(\frac{f_L}{f_L(n)} \right)^2 = 2^{1/n}$$

$$\left(\frac{f_L}{f_L(n)} \right)^2 = 2^{1/n} - 1$$

Taking square root on both sides

$$\left(\frac{f_L}{f_L(n)} \right) = \sqrt{2^n - 1}$$

$$f_L(n) = \frac{f_L}{\sqrt{2^n - 1}}$$

Higher 3dB frequency of multistage amplifier

The lower 3db frequency of n identical cascaded stages as $f_H(n)$. It is the frequency for which the overall gain falls to $\frac{1}{\sqrt{2}}$ (3 db) of its midband value.

$$\left[\frac{1}{\sqrt{1 + \left(\frac{f_H(n)}{f_H} \right)^2}} \right]^n = \frac{1}{\sqrt{2}}$$

$$\left[\sqrt{1 + \left(\frac{f_H(n)}{f_H} \right)^2} \right]^n = \sqrt{2}$$

Squaring on both sides we get

$$\left| 1 + \left(\frac{f_H(n)}{f_H} \right)^2 \right|^n = 2$$

Taking nth root on both sides

$$1 + \left(\frac{f_H(n)}{f_H} \right)^2 = 2^{1/n}$$

$$\left(\frac{f_H(n)}{f_H} \right)^2 = 2^{1/n} - 1$$

Taking square root on both sides

$$\left(\frac{f_H(n)}{f_H} \right) = \sqrt{2^{1/n} - 1}$$

$$f_H(n) = f_H \sqrt{2^{1/n} - 1}$$

UNIT-III

Feedback Amplifier & Oscillator

Feedback Amplifier

A practical amplifier has a gain of nearly one million *i.e.* its output is one million times the input. Consequently, even a casual disturbance at the input will appear in the amplified form in the output. There is a strong tendency in amplifiers to introduce *hum* due to sudden temperature changes or stray electric and magnetic fields. Therefore, every high gain amplifier tends to give noise along with signal in its output. The noise in the output of an amplifier is undesirable and must be kept to as small a level as possible. The noise level in amplifiers can be reduced considerably by the use of *negative feedback i.e.* by injecting a fraction of output in phase opposition to the input signal. The object of this chapter is to consider the effects and methods of providing negative feedback in transistor amplifiers.

Ideally an amplifier should reproduce the input signal, with change in magnitude and with or without change in phase. But some of the short comings of the amplifier circuit are

1. Change in the value of the gain due to variation in supplying voltage, temperature or due to components.
2. Distortion in wave-form due to non linearities in the operating characters of the Amplifying device.
3. The amplifier may introduce noise (undesired signals)

The above drawbacks can be minimizing if we introduce feedback

CLASSIFICATION OF AMPLIFIERS

Amplifiers can be classified broadly as,

1. Voltage amplifiers.
2. Current amplifiers.
3. Transconductance amplifiers.
4. Transresistance amplifiers.

1.1 Voltage amplifier

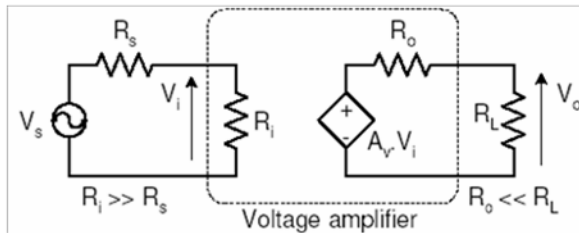

if $R_i \gg R_s$

then $V_i \approx V_s$

and if $R_o \ll R_L$

then

$$V_o \approx A_v V_i \approx A_v V_s$$

hence $A_v \equiv \frac{V_o}{V_i}$

with $R_L = \infty$

represent the open circuit voltage gain.

1.2 Current amplifier

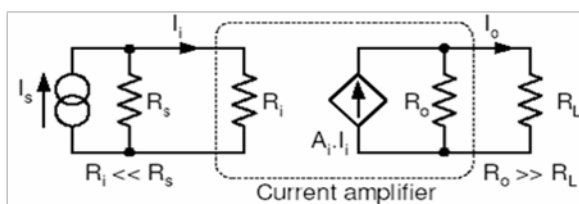

if $R_i \ll R_s$

then $I_i \approx I_s$

and if $R_o \gg R_L$

then

$$I_o \approx A_i I_i \approx A_i I_s$$

hence $A_i \equiv \frac{I_o}{I_i}$

with $R_L = 0$

represent the short circuit current gain.

1.3 Transconductance amplifier

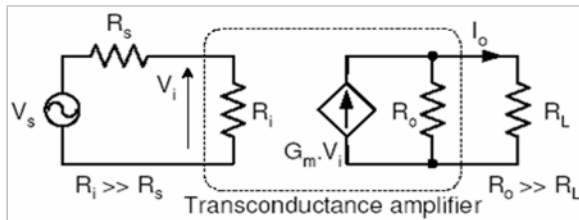

if $R_i \gg R_s$

then $V_i \approx V_s$

and if $R_o \gg R_L$

then

$$I_o \approx G_m V_i \approx G_m V_s$$

hence $G_m \equiv \frac{I_o}{V_i}$

with $R_L = 0$

represent the short circuit mutual or transfer conductance

1.4 Transresistance amplifier

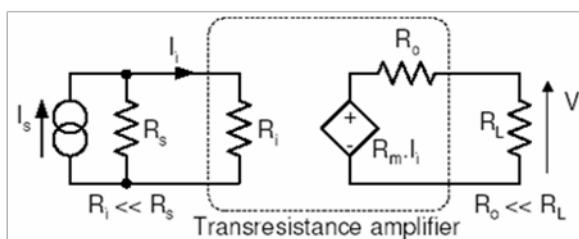

if $R_i \ll R_s$

then $I_i \approx I_s$

and if $R_o \ll R_L$

then

$$V_o \approx R_m I_i \approx R_m I_s$$

hence $R_m \equiv \frac{V_o}{I_i}$

with $R_L = \infty$

represent the open circuit mutual or transfer resistance.

Concept of Feedback

An amplifier circuit simply increases the signal strength. But while amplifying, it just increases the strength of its input signal whether it contains information or some noise along with information. This noise or some disturbance is introduced in the amplifiers because of their strong tendency to introduce hum due to sudden temperature changes or stray electric and magnetic fields. Therefore, every high gain amplifier tends to give noise along with signal in its output, which is very undesirable.

The noise level in the amplifier circuits can be considerably reduced by using negative feedback done by injecting a fraction of output in phase opposition to the input signal.

Principle of Feedback Amplifier

A feedback amplifier generally consists of two parts. They are the amplifier and the feedback circuit. The feedback circuit usually consists of resistors. The concept of feedback amplifier can be understood from the following figure.

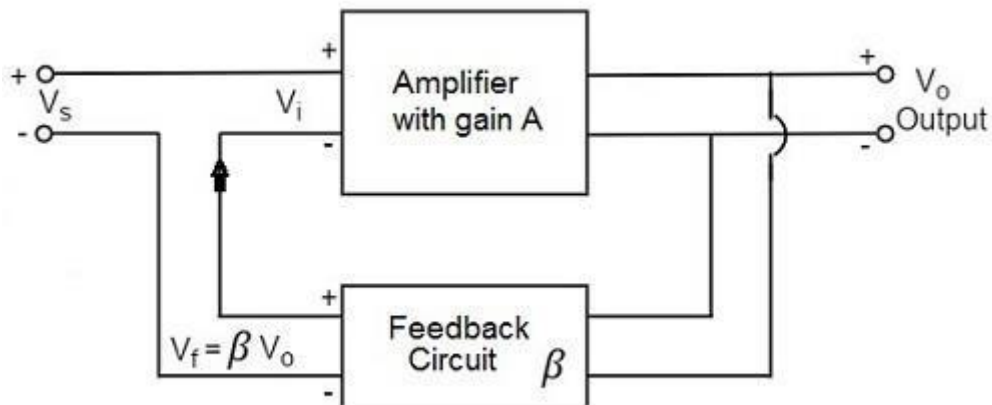

From the above figure, the gain of the amplifier is represented as A . the gain of the amplifier is the ratio of output voltage V_o to the input voltage V_i . the feedback network extracts a voltage $V_f = \beta V_o$ from the output V_o of the amplifier.

This voltage is added for positive feedback and subtracted for negative feedback, from the signal voltage V_s . Now,

$$V_i = V_s + V_f = V_s + \beta V_o$$

$$V_i = V_s - V_f = V_s - \beta V_o$$

The quantity $\beta = V_f/V_o$ is called as feedback ratio or feedback fraction.

Let us consider the case of negative feedback. The output V_o must be equal to the input voltage $(V_s - \beta V_o)$ multiplied by the gain A of the amplifier.

Hence,

$$(V_s - \beta V_o)A = V_o$$

Or

$$AV_s - A\beta V_o = V_o$$

Or

$$AV_s = V_o(1 + A\beta)$$

Therefore,

$$\frac{V_o}{V_s} = \frac{A}{1 + A\beta}$$

Let A_f be the overall gain (gain with the feedback) of the amplifier. This is defined as the ratio of output voltage V_o to the applied signal voltage V_s , i.e.,

$$A_f = \frac{A}{1 + A\beta}$$

The equation of gain of the feedback amplifier, with positive feedback is given by

$$A_f = \frac{A}{1 - A\beta}$$

These are the standard equations to calculate the gain of feedback amplifiers.

Types of Feedbacks

The process of injecting a fraction of output energy of some device back to the input is known as Feedback. It has been found that feedback is very useful in reducing noise and making the amplifier operation stable.

Depending upon whether the feedback signal aids or opposes the input signal, there are two types of feedbacks used.

Positive Feedback

The feedback in which the feedback energy i.e., either voltage or current is in phase with the input signal and thus aids it is called as Positive feedback.

Both the input signal and feedback signal introduces a phase shift of 180° thus making a 360° resultant phase shift around the loop, to be finally in phase with the input signal.

Though the positive feedback increases the gain of the amplifier, it has the disadvantages such as

- Increasing distortion
- Instability

It is because of these disadvantages the positive feedback is not recommended for the amplifiers. If the positive feedback is sufficiently large, it leads to oscillations, by which oscillator circuits are formed.

Negative Feedback

The feedback in which the feedback energy i.e., either voltage or current is out of phase with the input and thus opposes it, is called as negative feedback.

In negative feedback, the amplifier introduces a phase shift of 180° into the circuit while the feedback network is so designed that it produces no phase shift or zero phase shift. Thus the resultant feedback voltage V_f is 180° out of phase with the input signal V_{in} .

Though the gain of negative feedback amplifier is reduced, there are many advantages of negative feedback such as

- Stability of gain is improved
- Reduction in distortion
- Reduction in noise
- Increase in input impedance
- Decrease in output impedance
- Increase in the range of uniform application

It is because of these advantages negative feedback is frequently employed in amplifiers.

Negative feedback in an amplifier is the method of feeding a portion of the amplified output to the input but in opposite phase. The phase opposition occurs as the amplifier provides 180° phase shift whereas the feedback network doesn't.

While the output energy is being applied to the input, for the voltage energy to be taken as feedback, the output is taken in shunt connection and for the current energy to be taken as feedback, the output is taken in series connection.

There are two main types of negative feedback circuits. They are –

- Negative Voltage Feedback
- Negative Current Feedback

Negative Voltage Feedback

In this method, the voltage feedback to the input of amplifier is proportional to the output voltage. This is further classified into two types –

- Voltage-series feedback
- Voltage-shunt feedback

Negative Current Feedback

In this method, the voltage feedback to the input of amplifier is proportional to the output current. This is further classified into two types.

- Current-series feedback
- Current-shunt feedback

Let us have a brief idea on all of them.

Voltage-Series Feedback

In the voltage series feedback circuit, a fraction of the output voltage is applied in series with the input voltage through the feedback circuit. This is also known as shunt-driven series-fed feedback, i.e., a parallel-series circuit.

The following figure shows the block diagram of voltage series feedback, by which it is evident that the feedback circuit is placed in shunt with the output but in series with the input.

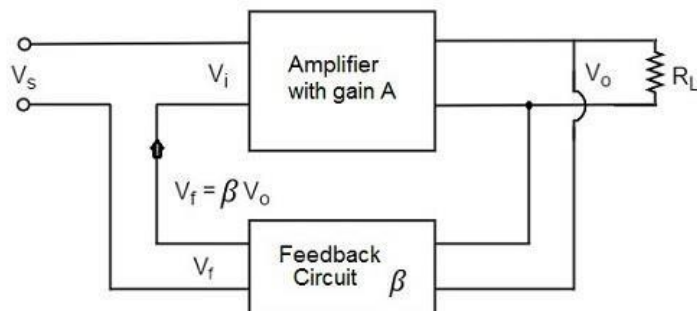

As the feedback circuit is connected in shunt with the output, the output impedance is decreased and due to the series connection with the input, the input impedance is increased.

Voltage-Shunt Feedback

In the voltage shunt feedback circuit, a fraction of the output voltage is applied in parallel with the input voltage through the feedback network. This is also known as shunt-driven shunt-fed feedback i.e., a parallel-parallel proto type.

The below figure shows the block diagram of voltage shunt feedback, by which it is evident that the feedback circuit is placed in shunt with the output and also with the input.

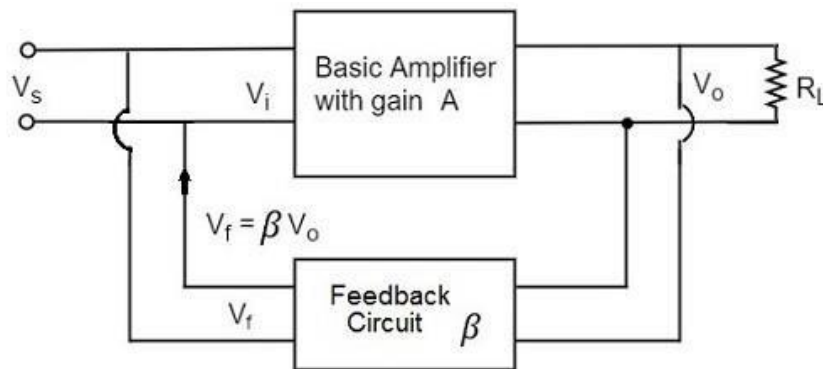

As the feedback circuit is connected in shunt with the output and the input as well, both the output impedance and the input impedance are decreased.

Current-Series Feedback

In the current series feedback circuit, a fraction of the output voltage is applied in series with the input voltage through the feedback circuit. This is also known as series-driven series-fed feedback i.e., a series-series circuit.

The following figure shows the block diagram of current series feedback, by which it is evident that the feedback circuit is placed in series with the output and also with the input.

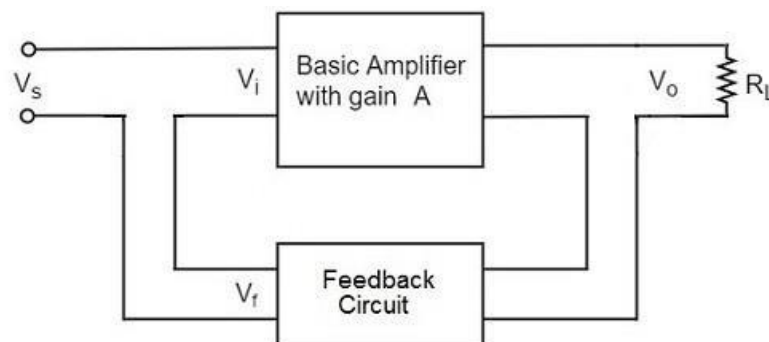

As the feedback circuit is connected in series with the output and the input as well, both the output impedance and the input impedance are increased.

Current-Shunt Feedback

In the current shunt feedback circuit, a fraction of the output voltage is applied in series with the input voltage through the feedback circuit. This is also known as series-driven shunt-fed feedback i.e., a series-parallel circuit.

The below figure shows the block diagram of current shunt feedback, by which it is evident that the feedback circuit is placed in series with the output but in parallel with the input.

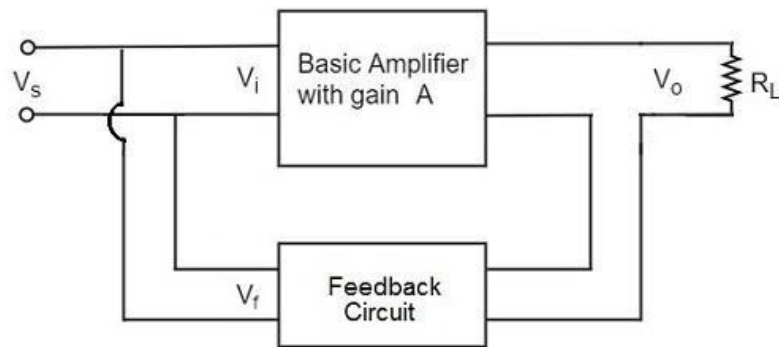

As the feedback circuit is connected in series with the output, the output impedance is increased and due to the parallel connection with the input, the input impedance is decreased.

Let us now tabulate the amplifier characteristics that get affected by different types of negative feedbacks.

Characteristics	Types of Feedback			
	Voltage-Series	Voltage-Shunt	Current-Series	Current-Shunt
Voltage Gain	Decreases	Decreases	Decreases	Decreases
Bandwidth	Increases	Increases	Increases	Increases
Input resistance	Increases	Decreases	Increases	Decreases
Output resistance	Decreases	Decreases	Increases	Increases
Harmonic distortion	Decreases	Decreases	Decreases	Decreases
Noise	Decreases	Decreases	Decreases	Decreases

EXPRESSION FOR INPUT RESISTANCE R_i WITH VOLTAGE SERIES FEEDBACK

In this circuit A_v represents the open circuit voltage gain taking R_s into account

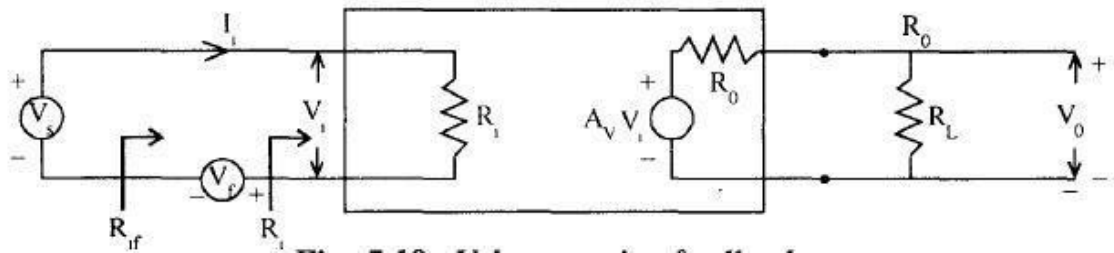

Voltage series feedback

$$R_{if} = \frac{V_s}{I_i}$$

Apply KVL to the input side circuit

$$V_s - I_i R_i - V_f = 0$$

$$V_s = I_i R_i + V_f = I_i R_i + \beta V_o$$

The output voltage V_o is given as

$$V_o = \frac{A_v V_i R_L}{R_o + R_L} = A \frac{V_i R_L}{R_o + R_L} = A \frac{V_i}{V_i} \frac{R_L}{R_o + R_L}$$

$$\text{Where } A_v = \frac{A_v R_L}{R_o + R_L}$$

A_v represents the open circuit voltage gain without feedback

A represents the open circuit voltage gain without feedback taking the load R_L into account.

$$V_s = I_i R_i + \beta A_v I_i R_i$$

$$R_{if} = \frac{V_s}{I_i} = R_i + \beta A_v R_i$$

$$R_{if} = R_i (1 + \beta A_v)$$

Similarly we can find

	Voltage-Series	Current-Series	Voltage-shunt	Current-Shunt
Z_i	$Z_i(1 + \beta A)$	$Z_i(1 + \beta A)$	$\frac{Z_i}{1 + \beta A}$	$\frac{Z_i}{1 + \beta A}$
Z_o	$\frac{Z_o}{1 + \beta A}$	$Z_o(1 + \beta A)$	$\frac{Z_o}{1 + \beta A}$	$Z_o(1 + \beta A)$

Advantages of Negative Feedback

1. *Stabilization of gain*
 - make the gain less sensitive to changes in circuit components e.g. due to changes in temperature.
2. *Reduce non-linear distortion*
 - make the output proportional to the input, keeping the gain constant, independent of signal level.
3. *Reduce the effect of noise*
 - minimize the contribution to the output of unwanted signals generated in circuit components or extraneous interference.
4. *Extend the bandwidth of the amplifier*
 - Reduce the gain and increase the bandwidth
5. *Modification the input and output impedances*
 - raise or lower the input and output impedances by selection of the appropriate feedback topology.

Oscillators

An **oscillator** generates output without any ac input signal. An electronic oscillator is a circuit which converts dc energy into ac at a very high frequency. An amplifier with a positive feedback can be understood as an oscillator.

Amplifier vs. Oscillator

An **amplifier** increases the signal strength of the input signal applied, whereas an **oscillator** generates a signal without that input signal, but it requires dc for its operation. This is the main difference between an amplifier and an oscillator.

Take a look at the following illustration. It clearly shows how an amplifier takes energy from d.c. power source and converts it into a.c. energy at signal frequency. An oscillator produces an oscillating a.c. signal on its own.

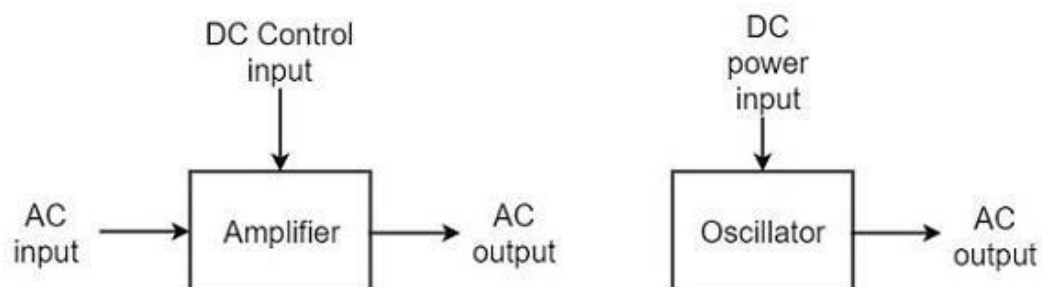

The frequency, waveform, and magnitude of a.c. power generated by an amplifier, is controlled by the a.c. signal voltage applied at the input, whereas those for an oscillator are controlled by the components in the circuit itself, which means no external controlling voltage is required.

Alternator vs. Oscillator

An **alternator** is a mechanical device that produces sinusoidal waves without any input. This a.c. generating machine is used to generate frequencies up to 1000Hz. The output frequency depends on the number of poles and the speed of rotation of the armature.

The following points highlight the differences between an alternator and an oscillator –

- An alternator converts mechanical energy to a.c. energy, whereas the oscillator converts d.c. energy into a.c. energy.
- An oscillator can produce higher frequencies of several MHz whereas an alternator cannot.
- An alternator has rotating parts, whereas an electronic oscillator doesn't.
- It is easy to change the frequency of oscillations in an oscillator than in an alternator.

Oscillators can also be considered as opposite to rectifiers that convert a.c. to d.c. as these convert d.c. to a.c.

Classification of Oscillators

Electronic oscillators are classified mainly into the following two categories –

- **Sinusoidal Oscillators** – The oscillators that produce an output having a sine waveform are called **sinusoidal** or **harmonic oscillators**. Such oscillators can provide output at frequencies ranging from 20 Hz to 1 GHz.
- **Non-sinusoidal Oscillators** – The oscillators that produce an output having a square, rectangular or saw-tooth waveform are called **non-sinusoidal** or **relaxation oscillators**. Such oscillators can provide output at frequencies ranging from 0 Hz to 20 MHz.

Sinusoidal Oscillators

Sinusoidal oscillators can be classified in the following categories –

- **Tuned Circuit Oscillators** – These oscillators use a tuned-circuit consisting of inductors (L) and capacitors (C) and are used to generate high-frequency signals. Thus they are also known as radio frequency R.F. oscillators. Such oscillators are Hartley, Colpitts, Clapp-oscillators etc.
- **RC Oscillators** – These oscillators use resistors and capacitors and are used to generate low or audio-frequency signals. Thus they are also known as audio-frequency (A.F.) oscillators. Such oscillators are Phase –shift and Wein-bridge oscillators.
- **Crystal Oscillators** – These oscillators use quartz crystals and are used to generate highly stabilized output signal with frequencies up to 10 MHz. The Piezo oscillator is an example of a crystal oscillator.
- **Negative-resistance Oscillator** – These oscillators use negative-resistance characteristic of the devices such as tunnel devices. A tuned diode oscillator is an example of a negative-resistance oscillator.

Nature of Sinusoidal Oscillations

The nature of oscillations in a sinusoidal wave is generally of two types. They are **damped** and **undamped oscillations**.

Damped Oscillations

The electrical oscillations whose amplitude goes on decreasing with time are called as **Damped Oscillations**. The frequency of the damped oscillations may remain constant depending upon the circuit parameters.

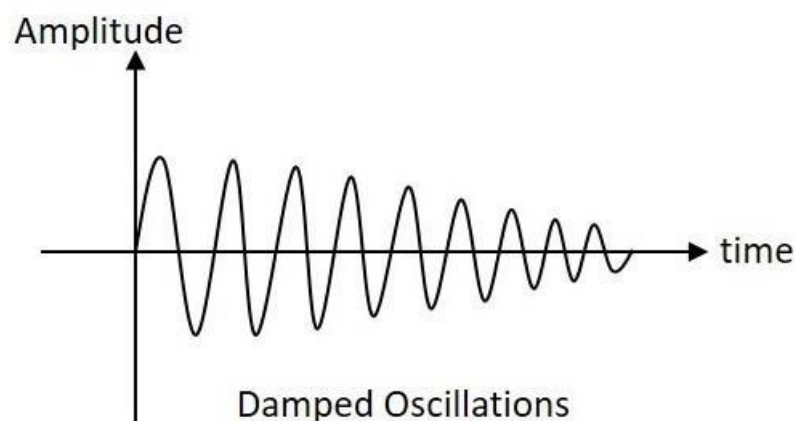

Damped oscillations are generally produced by the oscillatory circuits that produce power losses and doesn't compensate if required.

Undamped Oscillations

The electrical oscillations whose amplitude remains constant with time are called as **Undamped Oscillations**. The frequency of the Undamped oscillations remains constant.

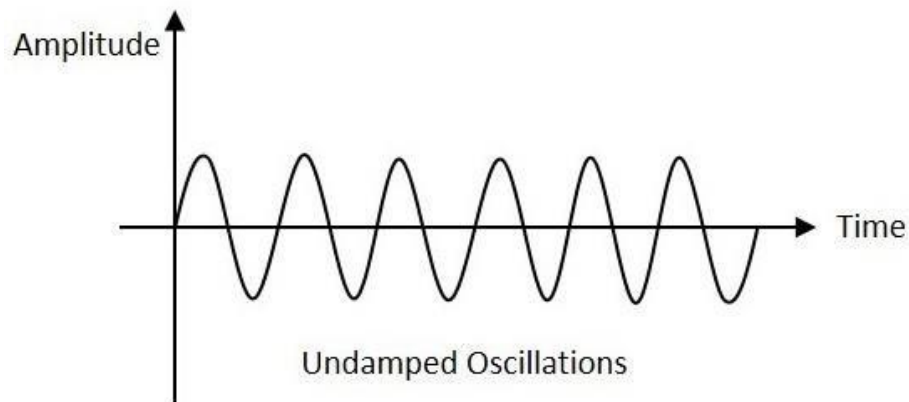

Undamped oscillations are generally produced by the oscillatory circuits that produce no power losses and follow compensation techniques if any power losses occur.

An amplifier with positive feedback produces its output to be in phase with the input and increases the strength of the signal. Positive feedback is also called as **degenerative feedback** or **direct feedback**. This kind of feedback makes a feedback amplifier, an oscillator.

The use of positive feedback results in a feedback amplifier having closed-loop gain greater than the open-loop gain. It results in **instability** and operates as an oscillatory circuit. An oscillatory circuit provides a constantly varying amplified output signal of any desired frequency.

The Barkhausen Criterion

With the knowledge we have till now, we understood that a practical oscillator circuit consists of a tank circuit, a transistor amplifier circuit and a feedback circuit. so, let us now try to brush up the concept of feedback amplifiers, to derive the gain of the feedback amplifiers.

Principle of Feedback Amplifier

A feedback amplifier generally consists of two parts. They are the **amplifier** and the **feedback circuit**. The feedback circuit usually consists of resistors. The concept of feedback amplifier can be understood from the following figure below.

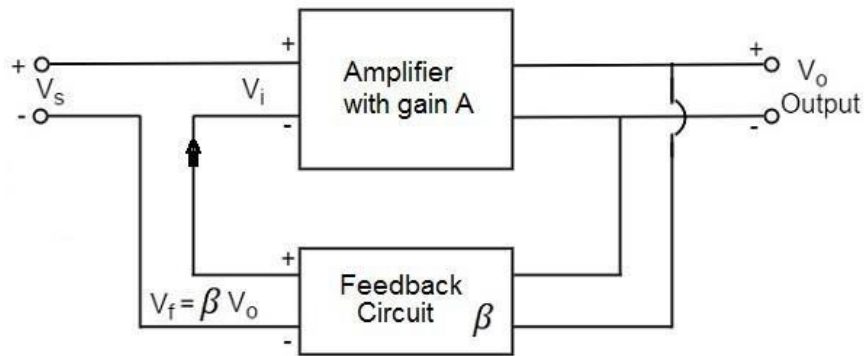

From the above figure, the gain of the amplifier is represented as A. The gain of the amplifier is the ratio of output voltage V_o to the input voltage V_i . The feedback network extracts a voltage $V_f = \beta V_o$ from the output V_o of the amplifier.

This voltage is added for positive feedback and subtracted for negative feedback, from the signal voltage V_s .

So, for a positive feedback,

$$V_i = V_s + V_f = V_s + \beta V_o$$

The quantity $\beta = V_f/V_o$ is called as feedback ratio or feedback fraction.

The output V_o must be equal to the input voltage $(V_s + \beta V_o)$ multiplied by the gain A of the amplifier.

Hence,

$$(V_s + \beta V_o)A = V_o$$

Or

$$AV_s + A\beta V_o = V_o$$

Or

$$AV_s = V_o(1 - A\beta)$$

Therefore

$$\frac{V_o}{V_s} = \frac{A}{1 - A\beta}$$

Let A_f be the overall gain (gain with the feedback) of the amplifier. This is defined as the ratio of output voltage V_o to the applied signal voltage V_s , i.e.,

$$A_f = \frac{\text{output voltage}}{\text{input signal voltage}} = \frac{V_o}{V_s}$$

From the above two equations, we can understand that, the equation of gain of the feedback amplifier with positive feedback is given by

$$A_f = \frac{A}{1 - A\beta}$$

Where $A\beta$ is the **feedback factor** or the **loop gain**.

If $A\beta = 1$, $A_f = \infty$. Thus the gain becomes infinity, i.e., there is output without any input. In another words, the amplifier works as an Oscillator.

The condition $A\beta = 1$ is called as **Barkhausen Criterion of oscillations**. This is a very important factor to be always kept in mind, in the concept of Oscillators

RC-Phase-shift Oscillators

Principle of Phase-shift oscillators

We know that the output voltage of an RC circuit for a sinewave input leads the input voltage. The phase angle by which it leads is determined by the value of RC components used in the circuit. The following circuit diagram shows a single section of an RC network.

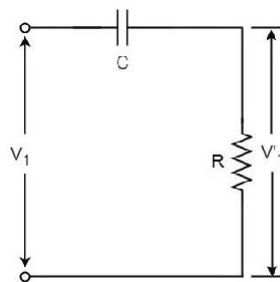

The output voltage V_1' across the resistor R leads the input voltage applied input V_1 by some phase angle ϕ° . If R were reduced to zero, V_1' will lead the V_1 by 90° i.e., $\phi^\circ = 90^\circ$.

However, adjusting R to zero would be impracticable, because it would lead to no voltage across R. Therefore, in practice, R is varied to such a value that makes V_1' to lead V_1 by 60° .

The following circuit diagram shows the three sections of the RC network.

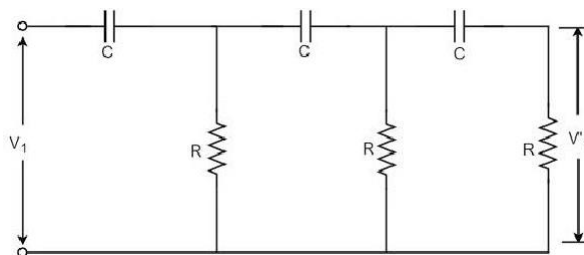

Each section produces a phase shift of 60° . Consequently, a total phase shift of 180° is produced, i.e., voltage V_2 leads the voltage V_1 by 180° .

Phase-shift Oscillator Circuit

The oscillator circuit that produces a sine wave using a phase-shift network is called as a Phase-shift oscillator circuit. The constructional details and operation of a phase-shift oscillator circuit are as given below.

Construction

The phase-shift oscillator circuit consists of a single transistor amplifier section and a RC phase-shift network. The phase shift network in this circuit, consists of three RC sections. At the resonant frequency f_o , the phase shift in each RC section is 60° so that the total phase shift produced by RC network is 180° .

The following circuit diagram shows the arrangement of an RC phase-shift oscillator.

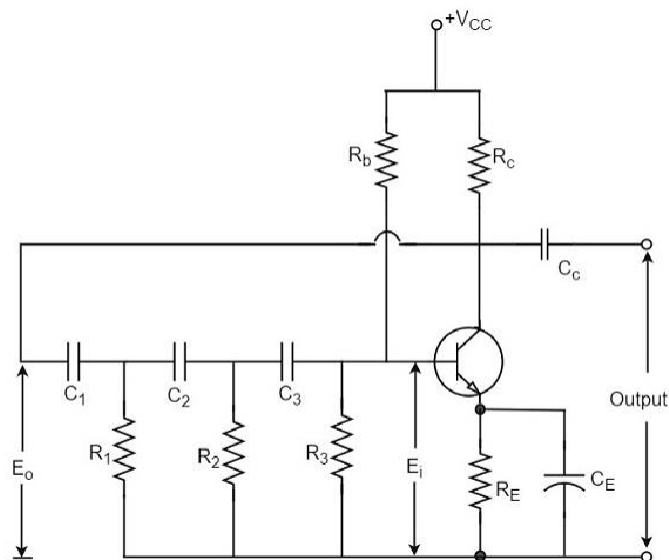

The frequency of oscillations is given by

$$f_o = \frac{1}{2\pi RC\sqrt{6}}$$

Where

$$R_1 = R_2 = R_3 = R$$

$$C_1 = C_2 = C_3 = C$$

Operation

The circuit when switched ON oscillates at the resonant frequency f_o . The output E_o of the amplifier is fed back to RC feedback network. This network produces a phase shift of 180° and a voltage E_i appears at its output. This voltage is applied to the transistor amplifier.

The feedback applied will be

$$m = E_i / E_o$$

The feedback is in correct phase, whereas the transistor amplifier, which is in CE configuration, produces a 180° phase shift. The phase shift produced by network and the transistor add to form a phase shift around the entire loop which is 360° .

Advantages

The advantages of RC phase shift oscillator are as follows –

- It does not require transformers or inductors.
- It can be used to produce very low frequencies.
- The circuit provides good frequency stability.

Disadvantages

The disadvantages of RC phase shift oscillator are as follows –

- Starting the oscillations is difficult as the feedback is small.
- The output produced is small.

Another type of popular audio frequency oscillator is the Wien bridge oscillator circuit. This is mostly used because of its important features. This circuit is free from the **circuit fluctuations** and the **ambient temperature**.

The main advantage of this oscillator is that the frequency can be varied in the range of 10Hz to about 1MHz whereas in RC oscillators, the frequency is not varied.

Wien bridge oscillator

Construction

The circuit construction of Wien bridge oscillator can be explained as below. It is a two-stage amplifier with RC bridge circuit. The bridge circuit has the arms R_1C_1 , R_3 , R_2C_2 and the tungsten lamp L_p . Resistance R_3 and the lamp L_p are used to stabilize the amplitude of the output.

The following circuit diagram shows the arrangement of a Wien bridge oscillator.

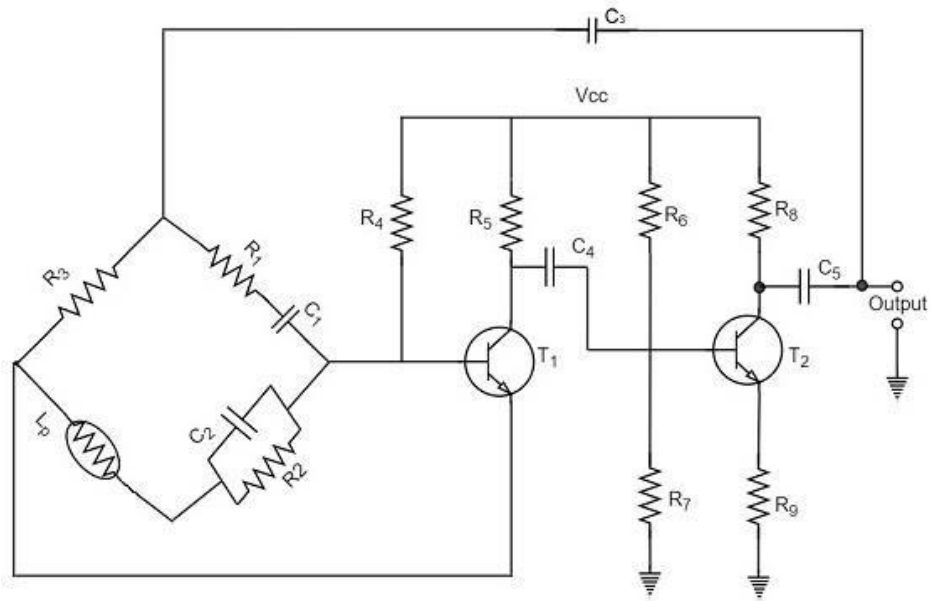

The transistor T_1 serves as an oscillator and an amplifier while the other transistor T_2 serves as an inverter. The inverter operation provides a phase shift of 180° . This circuit provides positive feedback through R_1C_1 , C_2R_2 to the transistor T_1 and negative feedback through the voltage divider to the input of transistor T_2 .

The frequency of oscillations is determined by the series element R_1C_1 and parallel element R_2C_2 of the bridge.

$$f = \frac{1}{2\pi\sqrt{R_1C_1R_2C_2}}$$

If $R_1 = R_2$ and $C_1 = C_2 = C$

Then,

$$f = \frac{1}{2\pi RC}$$

- It provides constant output.
- The operation of circuit is quite easy.
- The overall gain is high because of two transistors.
- The frequency of oscillations can be changed easily.
- The amplitude stability of the output voltage can be maintained more accurately, by replacing R_2 with a thermistor.

Disadvantages

The disadvantages of Wien bridge oscillator are as follows –

- The circuit cannot generate very high frequencies.
- Two transistors and number of components are required for the circuit construction.

LC Oscillators

An oscillatory circuit produces electrical oscillations of a desired frequency. They are also known as **tank circuits**.

A simple tank circuit comprises of an inductor L and a capacitor C both of which together determine the oscillatory frequency of the circuit.

To understand the concept of oscillatory circuit, let us consider the following circuit. The capacitor in this circuit is already charged using a dc source. In this situation, the upper plate of the capacitor has excess of electrons whereas the lower plate has deficit of electrons. The capacitor holds some electrostatic energy and there is a voltage across the capacitor.

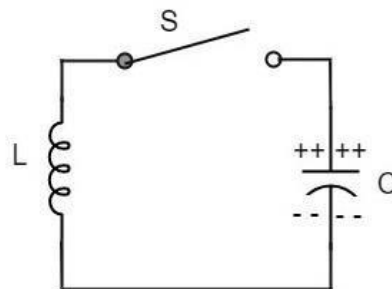

When the switch S is closed, the capacitor discharges and the current flows through the inductor. Due to the inductive effect, the current builds up slowly towards a maximum value. Once the capacitor discharges completely, the magnetic field around the coil is maximum.

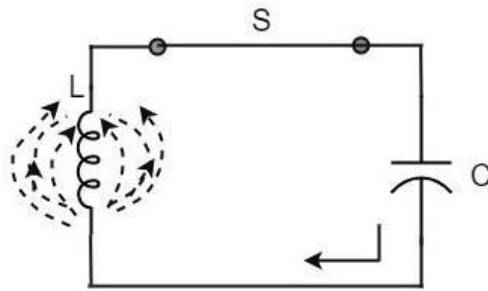

Now, let us move on to the next stage. Once the capacitor is discharged completely, the magnetic field begins to collapse and produces a counter EMF according to Lenz's law. The capacitor is now charged with positive charge on the upper plate and negative charge on the lower plate.

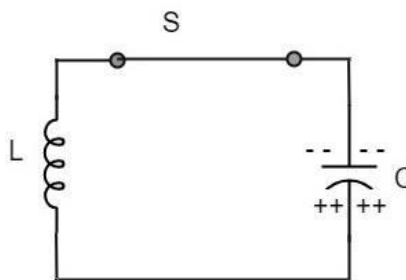

Once the capacitor is fully charged, it starts to discharge to build up a magnetic field around the coil, as shown in the following circuit diagram.

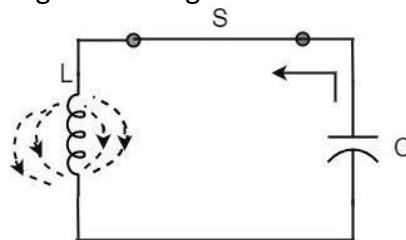

This continuation of charging and discharging results in alternating motion of electrons or an **oscillatory current**. The interchange of energy between L and C produce continuous **oscillations**.

In an ideal circuit, where there are no losses, the oscillations would continue indefinitely. In a practical tank circuit, there occur losses such as **resistive** and **radiation losses** in the coil and **dielectric losses** in the capacitor. These losses result in damped oscillations.

Frequency of Oscillations

The frequency of the oscillations produced by the tank circuit are determined by the components of the tank circuit, **the L** and **the C**. The actual frequency of oscillations is the **resonant frequency** (or natural frequency) of the tank circuit which is given by

$$f_r = \frac{1}{2\pi\sqrt{LC}}$$

Capacitance of the capacitor

The frequency of oscillation f_o is inversely proportional to the square root of the capacitance of a capacitor. So, if the value of the capacitor used is large, the charge and discharge time periods will be large. Hence the frequency will be lower.

Mathematically, the frequency,

$$f_o \propto \frac{1}{\sqrt{C}}$$

Self-Inductance of the coil

The frequency of the oscillation f_o is proportional to the square root of the self-inductance of the coil. If the value of the inductance is large, the opposition to change of current flow is greater and hence the time required to complete each cycle will be longer, which means time period will be longer and frequency will be lower.

Mathematically, the frequency,

$$f_o \propto \frac{1}{\sqrt{L}}$$

Combining both the above equations,

$$f_o \propto \frac{1}{\sqrt{LC}}$$

$$f_o = \frac{1}{2\pi\sqrt{LC}}$$

The above equation, though indicates the output frequency, matches the **natural frequency** or **resonance frequency** of the tank circuit.

An Oscillator circuit is a complete set of all the parts of circuit which helps to produce the oscillations. These oscillations should sustain and should be Undamped as just discussed before. Let us try to analyze a practical Oscillator circuit to have a better understanding on how an Oscillator circuit works.

Practical Oscillator Circuit

A Practical Oscillator circuit consists of a tank circuit, a transistor amplifier, and a feedback circuit. The following circuit diagram shows the arrangement of a practical oscillator.

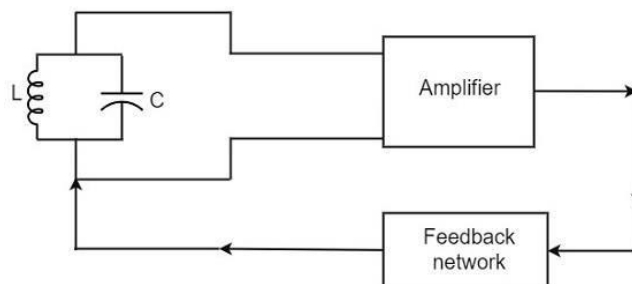

Let us now discuss the parts of this practical oscillator circuit.

Tank Circuit – The tank circuit consists of an inductance L connected in parallel with capacitor C . The values of these two components determine the frequency of the oscillator circuit and hence this is called as **Frequency determining circuit**.

- **Transistor Amplifier** – The output of the tank circuit is connected to the amplifier circuit so that the oscillations produced by the tank circuit are amplified here. Hence the output of these oscillations are increased by the amplifier.
- **Feedback Circuit** – The function of feedback circuit is to transfer a part of the output energy to LC circuit in proper phase. This feedback is positive in oscillators while negative in amplifiers.

Frequency Stability of an Oscillator

The frequency stability of an oscillator is a measure of its ability to maintain a constant frequency, over a long time interval. When operated over a longer period of time, the oscillator frequency may have a drift from the previously set value either by increasing or by decreasing.

The change in oscillator frequency may arise due to the following factors –

- Operating point of the active device such as BJT or FET used should lie in the linear region of the amplifier. Its deviation will affect the oscillator frequency.
- The temperature dependency of the performance of circuit components affect the oscillator frequency.
- The changes in d.c. supply voltage applied to the active device, shift the oscillator frequency. This can be avoided if a regulated power supply is used.
- A change in output load may cause a change in the Q-factor of the tank circuit, thereby causing a change in oscillator output frequency.
- The presence of inter element capacitances and stray capacitances affect the oscillator output frequency and thus frequency stability.

Tuned circuit oscillators are the circuits that produce oscillations with the help of tuning circuits. The tuning circuits consists of an inductance L and a capacitor C . These are also known as **LC oscillators, resonant circuit oscillators** or **tank circuit oscillators**.

The tuned circuit oscillators are used to produce an output with frequencies ranging from 1 MHz to 500 MHz. Hence these are also known as **R.F. Oscillators**. A BJT or a FET is used as an amplifier with tuned circuit oscillators. With an amplifier and an LC tank circuit, we can feedback a signal with right amplitude and phase to maintain oscillations.

Types of Tuned Circuit Oscillators

Most of the oscillators used in radio transmitters and receivers are of LC oscillators type. Depending upon the way the feedback is used in the circuit, the LC oscillators are divided as the following types.

- **Hartley Oscillator** – It uses inductive feedback.
- **Colpitts Oscillator** – It uses capacitive feedback.
- **Clapp Oscillator** – It uses capacitive feedback.

Hartley Oscillator

A very popular **local oscillator** circuit that is mostly used in **radio receivers** is the **Hartley Oscillator** circuit. The constructional details and operation of a Hartley oscillator are as discussed below.

Construction

In the circuit diagram of a Hartley oscillator shown below, the resistors R_1 , R_2 and R_e provide necessary bias condition for the circuit. The capacitor C_e provides a.c. ground thereby providing any signal degeneration. This also provides temperature stabilization.

The capacitors C_c and C_b are employed to block d.c. and to provide an a.c. path. The radio frequency choke (R.F.C) offers very high impedance to high frequency currents which means it shorts for d.c. and opens for a.c. Hence it provides d.c. load for collector and keeps currents out of d.c. supply

source Tank Circuit

The frequency determining network is a parallel resonant circuit which consists of the inductors L_1 and L_2 along with a variable capacitor C . The junction of L_1 and L_2 are earthed. The coil L_1 has its one end connected to base via C_c and the other to emitter via C_e . So, L_2 is in the output circuit. Both the coils L_1 and L_2 are inductively coupled and together form an **Auto-transformer**.

The following circuit diagram shows the arrangement of a Hartley oscillator. The tank circuit is **shunt fed** in this circuit. It can also be a **series-fed**.

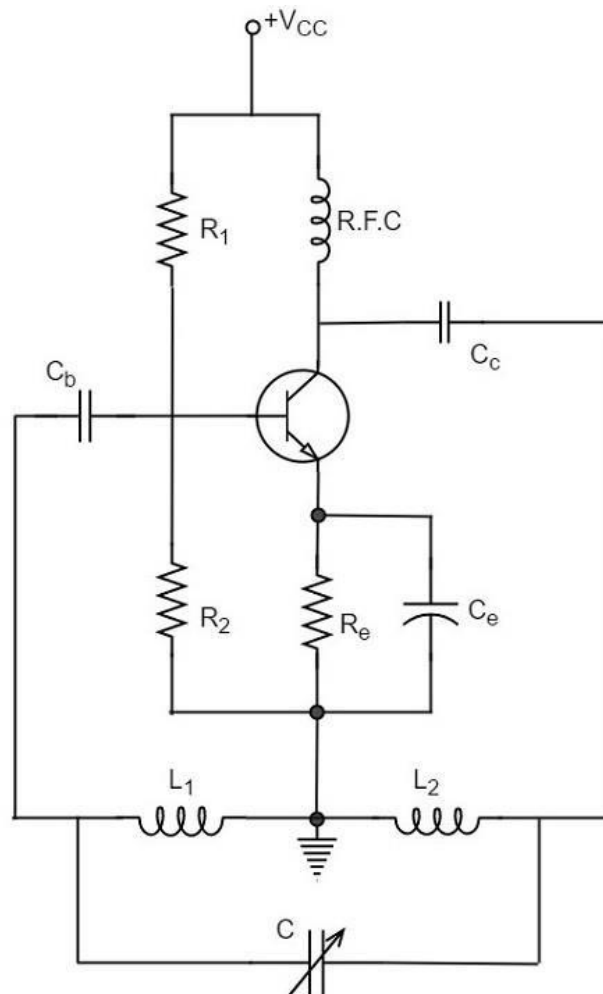

Operation

When the collector supply is given, a transient current is produced in the oscillatory or tank circuit. The oscillatory current in the tank circuit produces a.c. voltage across L_1 .

The **auto-transformer** made by the inductive coupling of L_1 and L_2 helps in determining the frequency and establishes the feedback. As the CE configured transistor provides 180° phase shift, another 180° phase shift is provided by the transformer, which makes 360° phase shift between the input and output voltages.

This makes the feedback positive which is essential for the condition of oscillations. When the **loop gain $|\beta A|$ of the amplifier is greater than one**, oscillations are sustained in the circuit.

Frequency

The equation for **frequency of Hartley oscillator** is given as

$$f = \frac{1}{2\pi\sqrt{L_T C}}$$

$$L_T = L_1 + L_2 + 2M$$

Here, L_T is the total cumulatively coupled inductance; L_1 and L_2 represent inductances of 1st and 2nd coils; and M represents mutual inductance.

Mutual inductance is calculated when two windings are considered.

Advantages

The advantages of Hartley oscillator are

- Instead of using a large transformer, a single coil can be used as an auto-transformer.
- Frequency can be varied by employing either a variable capacitor or a variable inductor.
- Less number of components are sufficient.
- The amplitude of the output remains constant over a fixed frequency range.

Disadvantages

The disadvantages of Hartley oscillator are

- It cannot be a low frequency oscillator.
- Harmonic distortions are present.

Applications

The applications of Hartley oscillator are

- It is used to produce a sinewave of desired frequency.
- Mostly used as a local oscillator in radio receivers.
- It is also used as R.F. Oscillator.

Colpitts oscillator

A Colpitts oscillator looks just like the Hartley oscillator but the inductors and capacitors are replaced with each other in the tank circuit. The constructional details and operation of a colpitts oscillator are as discussed below.

Construction

Let us first take a look at the circuit diagram of a Colpitts oscillator.

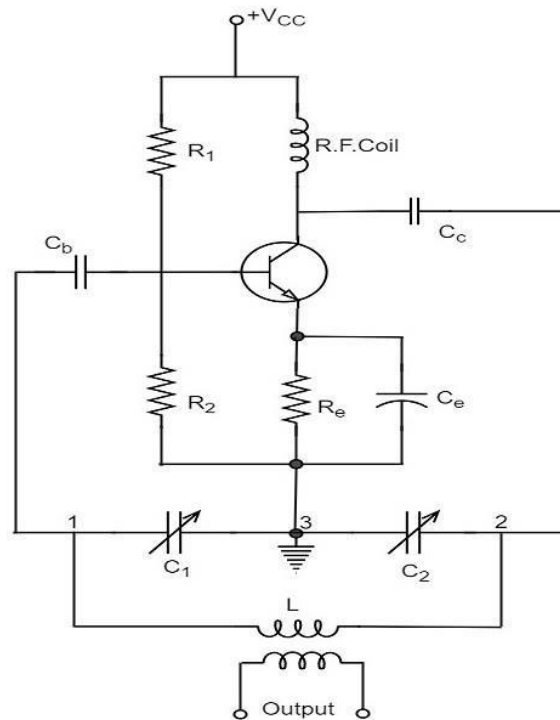

The resistors R_1 , R_2 and R_e provide necessary bias condition for the circuit. The capacitor C_e provides a.c. ground thereby providing any signal degeneration. This also provides temperature stabilization.

The capacitors C_c and C_b are employed to block d.c. and to provide an a.c. path. The radio frequency choke (R.F.C) offers very high impedance to high frequency currents which means it shorts for d.c. and opens for a.c. Hence it provides d.c. load for collector and keeps a.c. currents out of d.c. supply source.

Tank Circuit

The frequency determining network is a parallel resonant circuit which consists of variable capacitors C_1 and C_2 along with an inductor L . The junction of C_1 and C_2 are earthed. The capacitor C_1 has its one end connected to base via C_c and the other to emitter via C_e . The voltage developed across C_1 provides the regenerative feedback required for the sustained oscillations.

Operation

When the collector supply is given, a transient current is produced in the oscillatory or tank circuit. The oscillatory current in the tank circuit produces a.c. voltage across C_1 which are

applied to the base emitter junction and appear in the amplified form in the collector circuit and supply losses to the tank circuit.

If terminal 1 is at positive potential with respect to terminal 3 at any instant, then terminal 2 will be at negative potential with respect to 3 at that instant because terminal 3 is grounded. Therefore, points 1 and 2 are out of phase by 180° .

As the CE configured transistor provides 180° phase shift, it makes 360° phase shift between the input and output voltages. Hence, feedback is properly phased to produce continuous Undamped oscillations. When the **loop gain $|\beta A|$ of the amplifier is greater than one, oscillations are sustained** in the circuit.

Frequency

The equation for **frequency of Colpitts oscillator** is given as

$$f = \frac{1}{2\pi\sqrt{LC_T}}$$

C_T is the total capacitance of C_1 and C_2 connected in series.

$$\frac{1}{C_T} = \frac{1}{C_1} + \frac{1}{C_2}$$

$$C_T = \frac{C_1 \times C_2}{C_1 + C_2}$$

Advantages

The advantages of Colpitts oscillator are as follows –

- Colpitts oscillator can generate sinusoidal signals of very high frequencies.
- It can withstand high and low temperatures.
- The frequency stability is high.
- Frequency can be varied by using both the variable capacitors.
- Less number of components are sufficient.
- The amplitude of the output remains constant over a fixed frequency range.

The Colpitts oscillator is designed to eliminate the disadvantages of Hartley oscillator and is known to have no specific disadvantages. Hence there are many applications of a colpitts oscillator.

Applications

The applications of Colpitts oscillator are as follows –

- Colpitts oscillator can be used as High frequency sinewave generator.
- This can be used as a temperature sensor with some associated circuitry.
- Mostly used as a local oscillator in radio receivers.
- It is also used as R.F. Oscillator.
- It is also used in Mobile applications.
- It has got many other commercial applications.

Clapp Oscillator

Another oscillator which is an advanced version of Colpitts oscillator is the **Clapp Oscillator**. This circuit is designed by making a few changes to the Colpitts oscillator.

The circuit differs from the Colpitts oscillator only in one respect; it contains one additional capacitor (C_3) connected in series with the inductor. The addition of capacitor (C_3) improves the frequency stability and eliminates the effect of transistor parameters and stray capacitances.

The following circuit diagram shows the arrangement of a **transistor Clapp oscillator**.

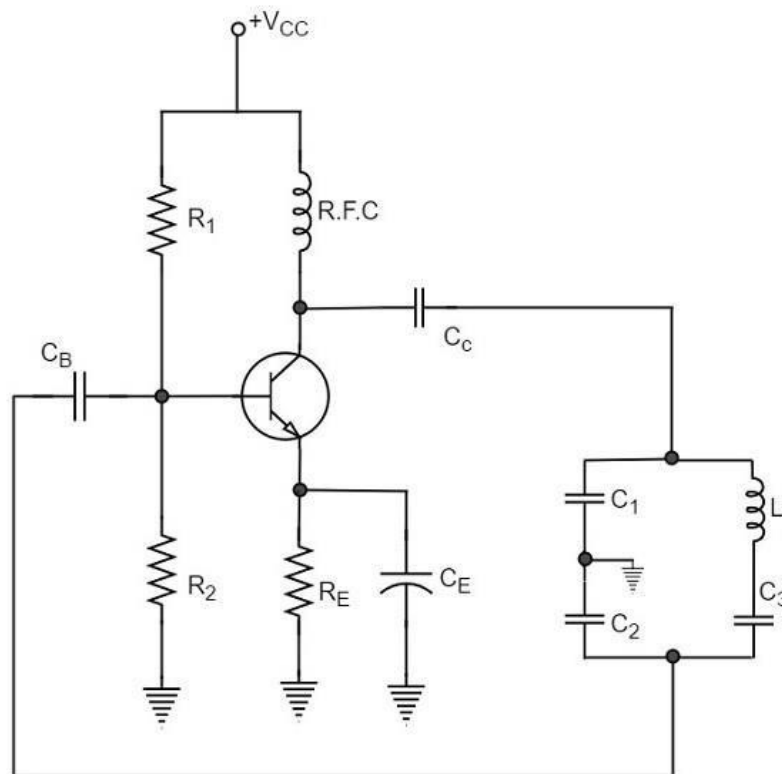

The operation of Clapp oscillator circuit is in the same way as that of Colpitts oscillator. The frequency of oscillator is given by the relation,

$$f_o = \frac{1}{2\pi\sqrt{L \cdot C}}$$

Where

$$C = \frac{1}{\frac{1}{C_1} + \frac{1}{C_2} + \frac{1}{C_3}}$$

Usually, the value of C_3 is much smaller than C_1 and C_2 . As a result of this, C is approximately equal to C_3 . Therefore, the frequency of oscillation,

$$f_o = \frac{1}{2\pi\sqrt{L \cdot C_3}}$$

It is understood that the Clapp oscillator is similar to the Colpitts oscillator, however they differ in the way the inductances and capacitances are arranged. The frequency stability though is good, can be variable in a Clapp oscillator.

A Clapp oscillator is sometimes preferred over a Colpitts oscillator for constructing a variable frequency oscillator. The Clapp oscillators are used in receiver tuning circuits as a frequency oscillator.

One of the important features of an oscillator is that the feedback energy applied should be in correct phase to the tank circuit. The oscillator circuits discussed so far has employed inductor (L) and capacitor (C) combination, in the tank circuit or frequency determining circuit.

We have observed that the LC combination in oscillators provide 180° phase shift and transistor in CE configuration provide 180° phase shift to make a total of 360° phase shift so that it would make a zero difference in phase.

Drawbacks of LC circuits

Though they have few applications, the LC circuits have few **drawbacks** such as

- Frequency instability
- Waveform is poor
- Cannot be used for low frequencies
- Inductors are bulky and expensive

Whenever an oscillator is under continuous operation, its **frequency stability** gets affected. There occur changes in its frequency. The main factors that affect the frequency of an oscillator are

- Power supply variations
- Changes in temperature
- Changes in load or output resistance

In RC and LC oscillators the values of resistance, capacitance and inductance vary with temperature and hence the frequency gets affected. In order to avoid this problem, the piezo electric crystals are being used in oscillators.

Crystal Oscillators

The use of piezo electric crystals in parallel resonant circuits provide high frequency stability in oscillators. Such oscillators are called as **Crystal Oscillators**.

Crystal Oscillators

The principle of crystal oscillators depends upon the **Piezo electric effect**. The natural shape of a crystal is hexagonal. When a crystal wafer is cut perpendicular to X-axis, it is called as X-cut and when it is cut along Y-axis, it is called as Y-cut.

The crystal used in crystal oscillator exhibits a property called as Piezo electric property. So, let us have an idea on piezo electric effect.

Piezo Electric Effect

The crystal exhibits the property that when a mechanical stress is applied across one of the faces of the crystal, a potential difference is developed across the opposite faces of the crystal. Conversely, when a potential difference is applied across one of the faces, a mechanical stress is produced along the other faces. This is known as **Piezo electric effect**.

Certain crystalline materials like Rochelle salt, quartz and tourmaline exhibit piezo electric effect and such materials are called as **Piezo electric crystals**. Quartz is the most commonly used piezo electric crystal because it is inexpensive and readily available in nature.

When a piezo electric crystal is subjected to a proper alternating potential, it vibrates mechanically. The amplitude of mechanical vibrations becomes maximum when the frequency of alternating voltage is equal to the natural frequency of the crystal.

Working of a Quartz Crystal

In order to make a crystal work in an electronic circuit, the crystal is placed between two metal plates in the form of a capacitor. **Quartz** is the mostly used type of crystal because of its availability and strong nature while being inexpensive. The ac voltage is applied in parallel to the crystal.

The circuit arrangement of a Quartz Crystal will be as shown below –

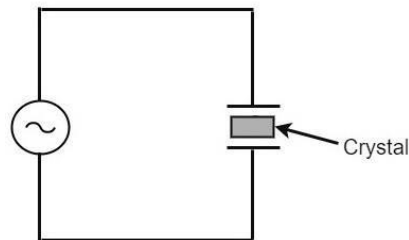

If an AC voltage is applied, the crystal starts vibrating at the frequency of the applied voltage. However, if the frequency of the applied voltage is made equal to the natural frequency of the crystal, **resonance** takes place and crystal vibrations reach a maximum value. This natural frequency is almost constant.

Equivalent circuit of a Crystal

If we try to represent the crystal with an equivalent electric circuit, we have to consider two cases, i.e., when it vibrates and when it doesn't. The figures below represent the symbol and electrical equivalent circuit of a crystal respectively.

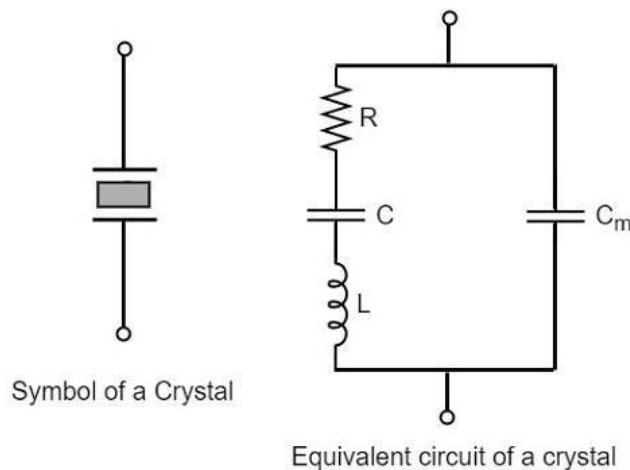

The above equivalent circuit consists of a series R-L-C circuit in parallel with a capacitance C_m . When the crystal mounted across the AC source is not vibrating, it is equivalent to the capacitance C_m . When the crystal vibrates, it acts like a tuned R-L-C circuit.

Frequency response

The frequency response of a crystal is as shown below. The graph shows the reactance (X_L or X_C) versus frequency (f). It is evident that the crystal has two closely spaced resonant frequencies.

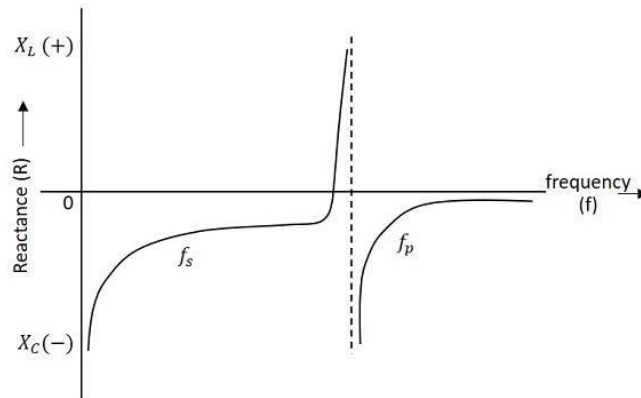

The first one is the series resonant frequency (f_s), which occurs when reactance of the inductance (L) is equal to the reactance of the capacitance C . In that case, the impedance of the equivalent circuit is equal to the resistance R and the frequency of oscillation is given by the relation,

$$f = \frac{1}{2\pi\sqrt{L \cdot C}}$$

The second one is the parallel resonant frequency (f_p), which occurs when the reactance of R - L - C branch is equal to the reactance of capacitor C_m . At this frequency, the crystal offers a very high impedance to the external circuit and the frequency of oscillation is given by the relation.

$$f_p = \frac{1}{2\pi\sqrt{L \cdot C_T}}$$

Where

$$C_T = \frac{CC_m}{(C + C_m)}$$

The value of C_m is usually very large as compared to C . Therefore, the value of C_T is approximately equal to C and hence the series resonant frequency is approximately equal to the parallel resonant frequency (i.e., $f_s = f_p$).

Crystal Oscillator Circuit

pierce crystal oscillator

A crystal oscillator circuit can be constructed in a number of ways like a Crystal controlled tuned collector oscillator, a Colpitts crystal oscillator, a Clap crystal oscillator etc. But the **transistor pierce crystal oscillator** is the most commonly used one. This is the circuit which is normally referred as a crystal oscillator circuit.

The following circuit diagram shows the arrangement of a transistor pierce crystal oscillator.

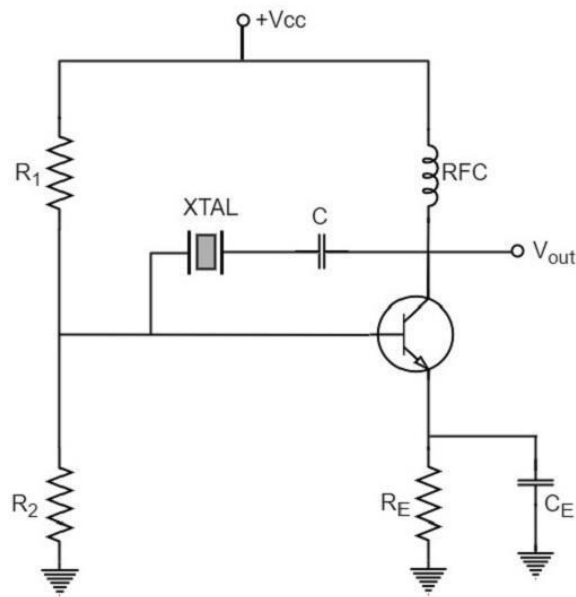

In this circuit, the crystal is connected as a series element in the feedback path from collector to the base. The resistors R₁, R₂ and R_E provide a voltage-divider stabilized d.c. bias circuit. The capacitor C_E provides a.c. bypass of the emitter resistor and RFC (radio frequency choke) coil provides for d.c. bias while decoupling any a.c. signal on the power lines from affecting the output signal. The coupling capacitor C has negligible impedance at the circuit operating frequency. But it blocks any d.c. between collector and base.

The circuit frequency of oscillation is set by the series resonant frequency of the crystal and its value is given by the relation,

$$f = \frac{1}{2\pi\sqrt{L.C}}$$

It may be noted that the changes in supply voltage, transistor device parameters etc. have no effect on the circuit operating frequency, which is held stabilized by the crystal.

Advantages

The advantages of crystal oscillator are as follows –

- They have a high order of frequency stability.
- The quality factor (Q) of the crystal is very high.

Disadvantages

The disadvantages of crystal oscillator are as follows –

- They are fragile and can be used in low power circuits.
- The frequency of oscillations cannot be changed appreciably.

Frequency Stability of an Oscillator

An Oscillator is expected to maintain its frequency for a longer duration without any variations, so as to have a smoother clear sinewave output for the circuit operation. Hence the term frequency stability really matters a lot, when it comes to oscillators, whether sinusoidal or non-sinusoidal.

The frequency stability of an oscillator is defined as the ability of the oscillator to maintain the required frequency constant over a long time interval as possible. Let us try to discuss the factors that affect this frequency stability.

Change in operating point

We have already come across the transistor parameters and learnt how important an operating point is. The stability of this operating point for the transistor being used in the circuit for amplification (BJT or FET), is of higher consideration.

The operating of the active device used is adjusted to be in the linear portion of its characteristics. This point is shifted due to temperature variations and hence the stability is affected.

Variation in temperature

The tank circuit in the oscillator circuit, contains various frequency determining components such as resistors, capacitors and inductors. All of their parameters are temperature dependent. Due to the change in temperature, their values get affected. This brings the change in frequency of the oscillator circuit.

Due to power supply

The variations in the supplied power will also affect the frequency. The power supply variations lead to the variations in V_{cc} . This will affect the frequency of the oscillations produced.

In order to avoid this, the regulated power supply system is implemented. This is in short called as RPS.

Change in output load

The variations in output resistance or output load also affects the frequency of the oscillator. When a load is connected, the effective resistance of the tank circuit is changed. As a result, the Q-factor of LC tuned circuit is changed. This results a change in output frequency of oscillator.

Changes in inter-element capacitances

Inter-element capacitances are the capacitances that develop in PN junction materials such as diodes and transistors. These are developed due to the charge present in them during their operation.

The inter element capacitors undergo change due to various reasons as temperature, voltage etc. This problem can be solved by connecting swamping capacitor across offending inter-element capacitor.

Value of Q

The value of Q (Quality factor) must be high in oscillators. The value of Q in tuned oscillators determine the selectivity. As this Q is directly proportional to the frequency stability of a tuned circuit, the value of Q should be maintained high.

Frequency stability can be mathematically represented as,

$$S_w = d\theta/d\omega$$

Where $d\theta$ is the phase shift introduced for a small frequency change in nominal frequency f_r . The circuit giving the larger value of $(d\theta/d\omega)$ has more stable oscillatory frequency.

UNIT-IV

Power Amplifiers

In practice, any amplifier consists of few stages of amplification. If we consider audio amplification, it has several stages of amplification, depending upon our requirement.

Power Amplifier

After the audio signal is converted into electrical signal, it has several voltage amplifications done, after which the power amplification of the amplified signal is done just before the loud speaker stage. This is clearly shown in the below figure.

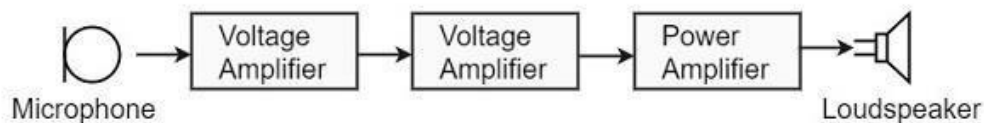

While the voltage amplifier raises the voltage level of the signal, the power amplifier raises the power level of the signal. Besides raising the power level, it can also be said that a power amplifier is a device which converts DC power to AC power and whose action is controlled by the input signal.

The DC power is distributed according to the relation,

DC power input = AC power output + losses

Power Transistor

For such Power amplification, a normal transistor would not do. A transistor that is manufactured to suit the purpose of power amplification is called as a **Power transistor**.

A Power transistor differs from the other transistors, in the following factors.

- It is larger in size, in order to handle large powers.
- The collector region of the transistor is made large and a heat sink is placed at the collector-base junction in order to minimize heat generated.
- The emitter and base regions of a power transistor are heavily doped.
- Due to the low input resistance, it requires low input power.

Hence there is a lot of difference in voltage amplification and power amplification. So, let us now try to get into the details to understand the differences between a voltage amplifier and a power amplifier.

Difference between Voltage and Power Amplifiers: Let us try to differentiate between voltage and power amplifier.

Voltage Amplifier

The function of a voltage amplifier is to raise the voltage level of the signal. A voltage amplifier is designed to achieve maximum voltage amplification.

The voltage gain of an amplifier is given by

$$A_v = \beta(R_c/R_{in})$$

The characteristics of a voltage amplifier are as follows –

- The base of the transistor should be thin and hence the value of β should be greater than 100.

- The resistance of the input resistor R_{in} should be low when compared to collector load R_c .
- The collector load R_c should be relatively high. To permit high collector load, the voltage amplifiers are always operated at low collector current.
- The voltage amplifiers are used for small signal voltages.

Power Amplifier

The function of a power amplifier is to raise the power level of input signal. It is required to deliver a large amount of power and has to handle large current.

The characteristics of a power amplifier are as follows –

- The base of transistor is made thicken to handle large currents. The value of β being ($\beta > 100$) high.
- The size of the transistor is made larger, in order to dissipate more heat, which is produced during transistor operation.
- Transformer coupling is used for impedance matching.
- Collector resistance is made low.

The comparison between voltage and power amplifiers is given below in a tabular form.

S.No	Particular	Voltage Amplifier	Power Amplifier
1	β	High (>100)	Low (5 to 20)
2	R_c	High (4-10 K Ω)	Low (5 to 20 Ω)
3	Coupling	Usually R-C coupling	Invariably transformer coupling
4	Input voltage	Low (a few m V)	High (2-4 V)
5	Collector current	Low (≈ 1 mA)	High (> 100 mA)
6	Power output	Low	High
7	Output impedance	High (≈ 12 K Ω)	Low (200 Ω)

The Power amplifiers amplify the power level of the signal. This amplification is done in the last stage in audio applications. The applications related to radio frequencies employ radio power amplifiers. But the **operating point** of a transistor plays a very important role in determining the efficiency of the amplifier. The **main classification** is done based on this mode of operation.

The classification is done based on their frequencies and also based on their mode of operation.

Classification Based on Frequencies

Power amplifiers are divided into two categories, based on the frequencies they handle. They are as follows.

- **Audio Power Amplifiers** – The audio power amplifiers raise the power level of signals that have audio frequency range (20 Hz to 20 KHz). They are also known as **Small signal power amplifiers**.
- **Radio Power Amplifiers** – Radio Power Amplifiers or tuned power amplifiers raise the power level of signals that have radio frequency range (3 KHz to 300 GHz). They are also known as **large signal power amplifiers**.

Classification Based on Mode of Operation

On the basis of the mode of operation, i.e., the portion of the input cycle during which collector current flows, the power amplifiers may be classified as follows.

- **Class A Power amplifier** – When the collector current flows at all times during the full cycle of signal, the power amplifier is known as **class A power amplifier**.
- **Class B Power amplifier** – When the collector current flows only during the positive half cycle of the input signal, the power amplifier is known as **class B power amplifier**.
- **Class C Power amplifier** – When the collector current flows for less than half cycle of the input signal, the power amplifier is known as **class C power amplifier**.

There forms another amplifier called Class AB amplifier, if we combine the class A and class B amplifiers so as to utilize the advantages of both. Before going into the details of these amplifiers, let us have a look at the important terms that have to be considered to determine the efficiency of an amplifier.

Terms Considering Performance

The primary objective of a power amplifier is to obtain maximum output power. In order to achieve this, the important factors to be considered are collector efficiency, power dissipation capability and distortion. Let us go through them in detail.

Collector Efficiency

This explains how well an amplifier converts DC power to AC power. When the DC supply is given by the battery but no AC signal input is given, the collector output at such a condition is observed as **collector efficiency**.

The collector efficiency is defined as

$$\eta = \text{average a.c power output} / \text{average d.c power input to transistor}$$

The main aim of a power amplifier is to obtain maximum collector efficiency. Hence the higher the value of collector efficiency, the efficient the amplifier will be.

Power Dissipation Capacity

Every transistor gets heated up during its operation. As a power transistor handles large currents, it gets more heated up. This heat increases the temperature of the transistor, which alters the operating point of the transistor. So, in order to maintain the operating point stability, the temperature of the transistor has to be kept in permissible limits. For this, the heat produced has to be dissipated. Such a capacity is called as Power dissipation capability.

Power dissipation capability can be defined as the ability of a power transistor to dissipate the heat developed in it. Metal cases called heat sinks are used in order to dissipate the heat produced in power transistors.

Distortion

A transistor is a non-linear device. When compared with the input, there occur few variations in the output. In voltage amplifiers, this problem is not pre-dominant as small

currents are used. But in power amplifiers, as large currents are in use, the problem of distortion certainly arises.

Distortion is defined as the change of output wave shape from the input wave shape of the amplifier. An amplifier that has lesser distortion, produces a better output and hence considered efficient.

We have already come across the details of transistor biasing, which is very important for the operation of a transistor as an amplifier. Hence to achieve faithful amplification, the biasing of the transistor has to be done such that the amplifier operates over the linear region.

A Class A power amplifier is one in which the output current flows for the entire cycle of the AC input supply. Hence the complete signal present at the input is amplified at the output. The following figure shows the circuit diagram for Class A Power amplifier.

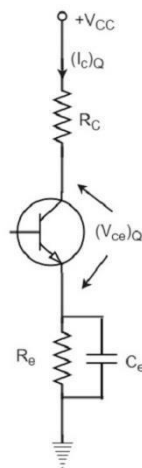

From the above figure, it can be observed that the transformer is present at the collector as a load. The use of transformer permits the impedance matching, resulting in the transference of maximum power to the load e.g. loud speaker.

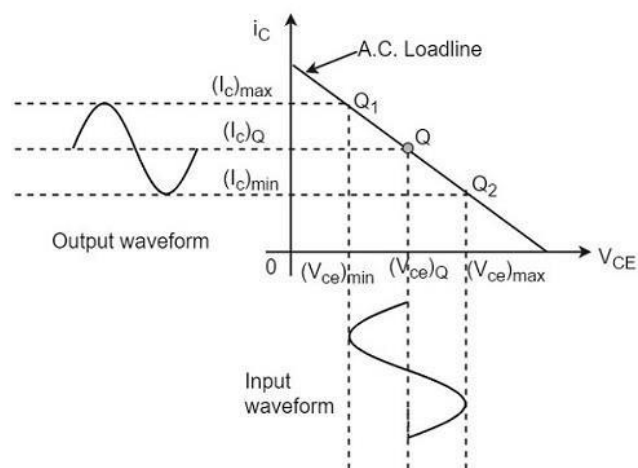

The operating point of this amplifier is present in the linear region. It is so selected that the current flows for the entire ac input cycle. The below figure explains the selection of operating point.

The output characteristics with operating point Q is shown in the figure above. Here $(I_c)_Q$ and $(V_{ce})_Q$ represent no signal collector current and voltage between collector and emitter respectively. When signal is applied, the Q-point shifts to Q_1 and Q_2 . The output current increases to $(I_c)_{max}$ and decreases to $(I_c)_{min}$. Similarly, the collector-emitter voltage increases to $(V_{ce})_{max}$ and decreases to $(V_{ce})_{min}$.

D.C. Power drawn from collector battery V_{cc} is given by

$$P_{in} = \text{voltage} \times \text{current} = V_{cc}(I_c)_Q$$

This power is used in the following two parts –

- Power dissipated in the collector load as heat is given by

$$P_{RC} = (\text{current})^2 \times \text{resistance} = (I_c)_Q^2 R_C$$

- Power given to transistor is given by

$$P_{tr} = P_{in} - P_{RC} = V_{cc} - (I_c)_Q R_C$$

When signal is applied, the power given to transistor is used in the following two parts –

- A.C. Power developed across load resistors R_C which constitutes the a.c. power output.

$$(P_o)_{ac} = I^2 R_C = V^2 / R_C = (V_m / \sqrt{2})^2 / R_C = V_m^2 / 2R_C$$

- Where I is the R.M.S. value of a.c. output current through load, V is the R.M.S. value of a.c. voltage, and V_m is the maximum value of V .
- The D.C. power dissipated by the transistor (collector region) in the form of heat, i.e., $(P_C)_{dc}$

We have represented the whole power flow in the following diagram.

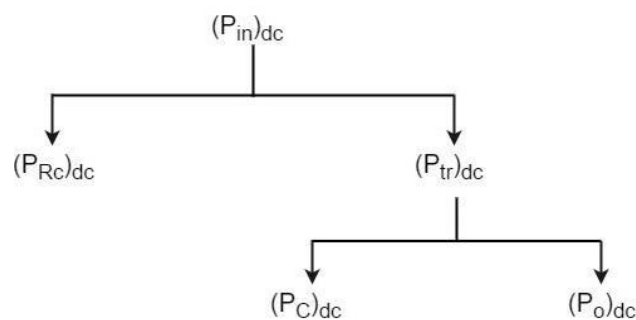

This class A power amplifier can amplify small signals with least distortion and the output will be an exact replica of the input with increased strength.

Let us now try to draw some expressions to represent efficiencies.

Overall Efficiency

The overall efficiency of the amplifier circuit is given by

$$\begin{aligned} (\eta)_{overall} &= \frac{\text{a. c power delivered to the load}}{\text{total power delivered by d. c supply}} \\ &= \frac{(P_O)_{ac}}{(P_{in})_{dc}} \end{aligned}$$

Collector Efficiency

The collector efficiency of the transistor is defined as

$$\begin{aligned} (\eta)_{collector} &= \frac{\text{average a. c power output}}{\text{average d. c power input to transistor}} \\ &= \frac{(P_O)_{ac}}{(P_{tr})_{dc}} \end{aligned}$$

Expression for overall efficiency

$$\begin{aligned} (P_O)_{ac} &= V_{rms} \times I_{rms} \\ &= \frac{1}{\sqrt{2}} \left[\frac{(V_{ce})_{max} - (V_{ce})_{min}}{2} \right] \times \frac{1}{\sqrt{2}} \left[\frac{(I_C)_{max} - (I_C)_{min}}{2} \right] \\ &= \frac{[(V_{ce})_{max} - (V_{ce})_{min}] \times [(I_C)_{max} - (I_C)_{min}]}{8} \end{aligned}$$

Advantages of Class A Amplifiers

The advantages of Class A power amplifier are as follows –

- The current flows for complete input cycle
- It can amplify small signals
- The output is same as input
- No distortion is present

Disadvantages of Class A Amplifiers

The disadvantages of Class A power amplifier are as follows –

- Low power output
- Low collector efficiency

The class A power amplifier as discussed in the previous chapter, is the circuit in which the output current flows for the entire cycle of the AC input supply. We also have learnt about the disadvantages it has such as low output power and efficiency. In order to

minimize those effects, the transformer coupled class A power amplifier has been introduced.

The **construction of class A power amplifier** can be understood with the help of below figure. This is similar to the normal amplifier circuit but connected with a transformer in the collector load.

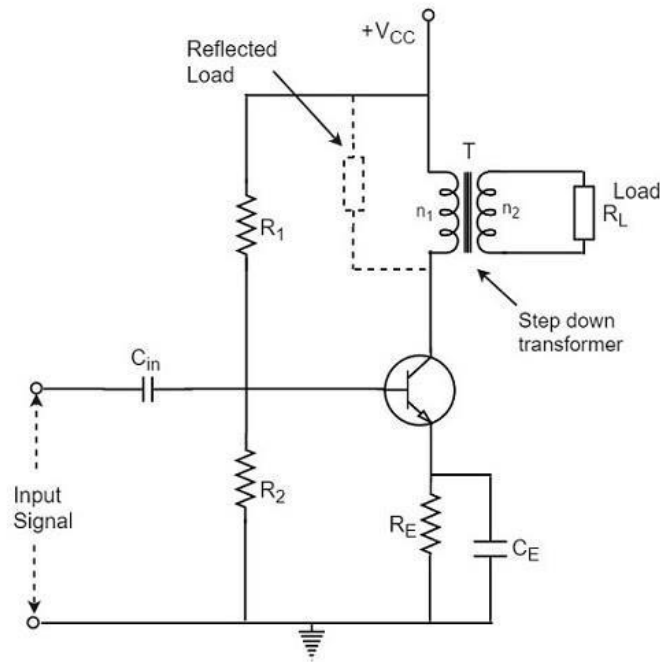

Here R_1 and R_2 provide potential divider arrangement. The resistor R_e provides stabilization, C_e is the bypass capacitor and R_e to prevent a.c. voltage. The transformer used here is a step-down transformer. The high impedance primary of the transformer is connected to the high impedance collector circuit. The low impedance secondary is connected to the load (generally loud speaker).

Transformer Action:

The transformer used in the collector circuit is for impedance matching. R_L is the load connected in the secondary of a transformer. R_L' is the reflected load in the primary of the transformer.

The number of turns in the primary are n_1 and the secondary are n_2 . Let V_1 and V_2 be the primary and secondary voltages and I_1 and I_2 be the primary and secondary currents respectively. The below figure shows the transformer clearly.

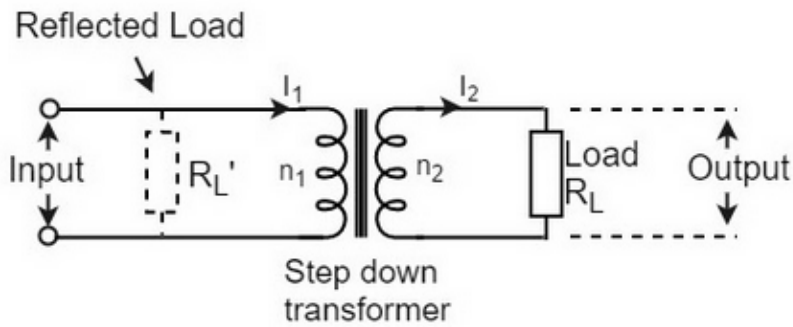

We know that

$$\frac{V_1}{V_2} = \frac{n_1}{n_2} \text{ and } \frac{I_1}{I_2} = \frac{n_1}{n_2}$$

Or

$$V_1 = \frac{n_1}{n_2} V_2 \text{ and } I_1 = \frac{n_1}{n_2} I_2$$

Hence

$$\frac{V_1}{I_1} = \left(\frac{n_1}{n_2} \right)^2 \frac{V_2}{I_2}$$

But $V_1/I_1 = R_L' =$ effective input resistance

And $V_2/I_2 = R_L =$ effective output resistance

Therefore,

$$R_L' = \left(\frac{n_1}{n_2} \right)^2 R_L = n^2 R_L$$

Where

$$n = \frac{\text{number of turns in primary}}{\text{number of turns in secondary}} = \frac{n_1}{n_2}$$

A power amplifier may be matched by taking proper turn ratio in step down transformer.

Circuit Operation

If the peak value of the collector current due to signal is equal to zero signal collector current, then the maximum a.c. power output is obtained. So, in order to achieve complete amplification, the operating point should lie at the center of the load line.

The operating point obviously varies when the signal is applied. The collector voltage varies in opposite phase to the collector current. The variation of collector voltage appears across the primary of the transformer.

Circuit Analysis

The power loss in the primary is assumed to be negligible, as its resistance is very small.

The input power under dc condition will be

$$(P_{in})_{dc} = (P_{tr})_{dc} = V_{CC} \times (I_C)Q$$

Under maximum capacity of class A amplifier, voltage swings from $(V_{ce})_{max}$ to zero and current from $(I_C)_{max}$ to zero.

Hence

$$V_{rms} = \frac{1}{\sqrt{2}} \left[\frac{(V_{ce})_{max} - (V_{ce})_{min}}{2} \right] = \frac{1}{\sqrt{2}} \left[\frac{(V_{ce})_{max}}{2} \right] = \frac{2V_{CC}}{2\sqrt{2}} \\ = \frac{V_{CC}}{\sqrt{2}}$$

$$I_{rms} = \frac{1}{\sqrt{2}} \left[\frac{(I_C)_{max} - (I_C)_{min}}{2} \right] = \frac{1}{\sqrt{2}} \left[\frac{(I_C)_{max}}{2} \right] = \frac{2(I_C)Q}{2\sqrt{2}} \\ = \frac{(I_C)Q}{\sqrt{2}}$$

Therefore,

$$(P_O)_{ac} = V_{rms} \times I_{rms} = \frac{V_{CC}}{\sqrt{2}} \times \frac{(I_C)Q}{\sqrt{2}} = \frac{V_{CC} \times (I_C)Q}{2}$$

Therefore,

$$\text{Collector Efficiency} = \frac{(P_O)_{ac}}{(P_{tr})_{dc}}$$

Or,

$$(\eta)_{collector} = \frac{V_{CC} \times (I_C)Q}{2 \times V_{CC} \times (I_C)Q} = \frac{1}{2} \\ = \frac{1}{2} \times 100 = 50\%$$

The efficiency of a class A power amplifier is nearly than 30% whereas it has got improved to 50% by using the transformer coupled class A power amplifier.

Advantages

The advantages of transformer coupled class A power amplifier are as follows.

- No loss of signal power in the base or collector resistors.
- Excellent impedance matching is achieved.
- Gain is high.
- DC isolation is provided.

Disadvantages

The disadvantages of transformer coupled class A power amplifier are as follows.

- Low frequency signals are less amplified comparatively.

- Hum noise is introduced by transformers.
- Transformers are bulky and costly.
- Poor frequency response.

Applications

The applications of transformer coupled class A power amplifier are as follows. This circuit is where impedance matching is the main criterion. These are used as driver amplifiers and sometimes as output amplifiers. When the collector current flows only during the positive half cycle of the input signal, the power amplifier is known as **class B power amplifier**.

Class B Operation

The biasing of the transistor in class B operation is in such a way that at zero signal condition, there will be no collector current. The **operating point** is selected to be at collector cut off voltage. So, when the signal is applied, **only the positive half cycle** is amplified at the output.

The figure below shows the input and output waveforms during class B operation.

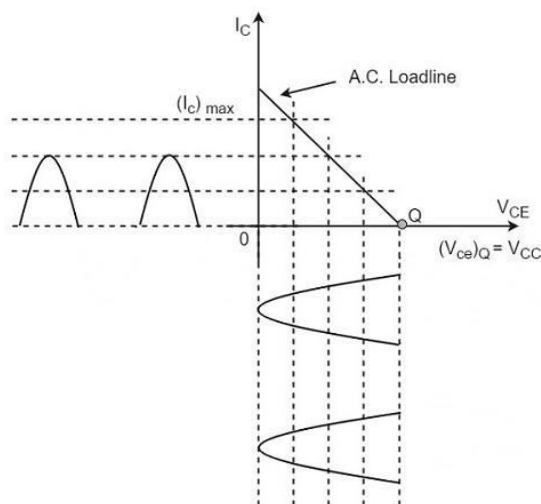

When the signal is applied, the circuit is forward biased for the positive half cycle of the input and hence the collector current flows. But during the negative half cycle of the input, the circuit is reverse biased and the collector current will be absent. Hence **only the positive half cycle** is amplified at the output.

As the negative half cycle is completely absent, the signal distortion will be high. Also, when the applied signal increases, the power dissipation will be more. But when compared to class A power amplifier, the output efficiency is increased. Well, in order to minimize the disadvantages and achieve low distortion, high efficiency and high output power, the push-pull configuration is used in this class B amplifier.

Class B Push-Pull Amplifier

Though the efficiency of class B power amplifier is higher than class A, as only one half cycle of the input is used, the distortion is high. Also, the input power is not completely utilized. In order to compensate these problems, the push-pull configuration is introduced in class B amplifier.

Construction:

The circuit of a push-pull class B power amplifier consists of two identical transistors T_1 and T_2 whose bases are connected to the secondary of the center-tapped input transformer T_{r1} . The emitters are shorted and the collectors are given the V_{CC} supply through the primary of the output transformer T_{r2} .

The circuit arrangement of class B push-pull amplifier, is same as that of class A push-pull amplifier except that the transistors are biased at cut off, instead of using the biasing resistors. The figure below gives the detailing of the construction of a push-pull class B power amplifier.

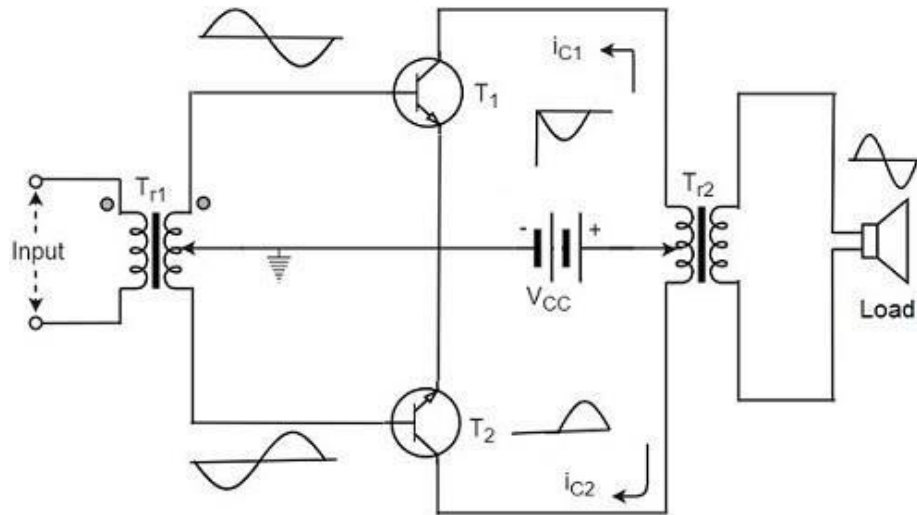

The circuit operation of class B push pull amplifier is detailed below.

Operation

The circuit of class B push-pull amplifier shown in the above figure clears that both the transformers are center-tapped. When no signal is applied at the input, the transistors T_1 and T_2 are in cut off condition and hence no collector currents flow. As no current is drawn from V_{CC} , no power is wasted.

When input signal is given, it is applied to the input transformer T_{r1} which splits the signal into two signals that are 180° out of phase with each other. These two signals are given to the two identical transistors T_1 and T_2 . For the positive half cycle, the base of the transistor T_1 becomes positive and collector current flows. At the same time, the transistor T_2 has negative half cycle, which throws the transistor T_2 into cutoff condition and hence no collector current flows. The waveform is produced as shown in the following figure.

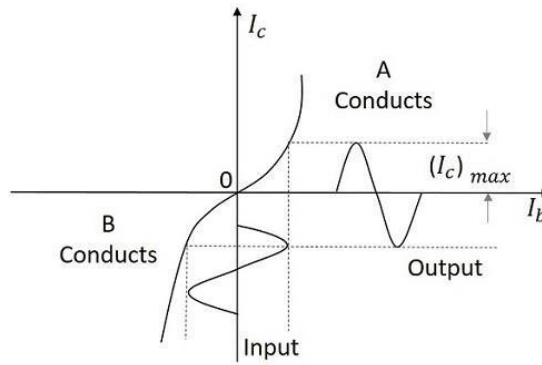

For the next half cycle, the transistor T_1 gets into cut off condition and the transistor T_2 gets into conduction, to contribute the output. Hence for both the cycles, each transistor conducts alternately. The output transformer T_{r3} serves to join the two currents producing an almost undistorted output waveform.

Power Efficiency of Class B Push-Pull Amplifier

The current in each transistor is the average value of half sine loop.

For half sine loop, I_{dc} is given by

$$I_{dc} = \frac{(I_C)_{max}}{\pi}$$

Therefore,

$$(P_{in})_{dc} = 2 \times \left[\frac{(I_C)_{max}}{\pi} \times V_{CC} \right]$$

Here factor 2 is introduced as there are two transistors in push-pull amplifier.

R.M.S. value of collector current = $(I_C)_{max} / \sqrt{2}$

R.M.S. value of output voltage = $V_{CC} / \sqrt{2}$

Under ideal conditions of maximum power

Therefore,

$$(P_O)_{ac} = \frac{(I_C)_{max}}{\sqrt{2}} \times \frac{V_{CC}}{\sqrt{2}} = \frac{(I_C)_{max} \times V_{CC}}{2}$$

Now overall maximum efficiency

$$\begin{aligned} \eta_{overall} &= \frac{(P_O)_{ac}}{(P_{in})_{dc}} \\ &= \frac{(I_C)_{max} \times V_{CC}}{2} \times \frac{\pi}{2(I_C)_{max} \times V_{CC}} \\ &= \frac{\pi}{4} = 0.785 = 78.5\% \end{aligned}$$

The collector efficiency would be the same.

Hence the class B push-pull amplifier improves the efficiency than the class A push-pull amplifier.

Complementary Symmetry Push-Pull Class B Amplifier

The push pull amplifier which was just discussed improves efficiency but the usage of center-tapped transformers makes the circuit bulky, heavy and costly. To make the circuit simple and to improve the efficiency, the transistors used can be complemented, as shown in the following circuit diagram.

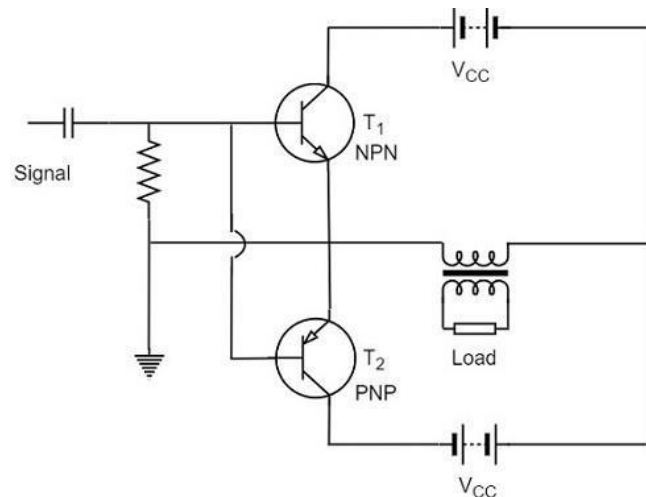

The above circuit employs a NPN transistor and a PNP transistor connected in push pull configuration. When the input signal is applied, during the positive half cycle of the input signal, the NPN transistor conducts and the PNP transistor cuts off. During the negative half cycle, the NPN transistor cuts off and the PNP transistor conducts.

In this way, the NPN transistor amplifies during positive half cycle of the input, while PNP transistor amplifies during negative half cycle of the input. As the transistors are both complement to each other, yet act symmetrically while being connected in push pull configuration of class B, this circuit is termed as **Complementary symmetry push pull class B amplifier**.

Advantages

The advantages of Complementary symmetry push pull class B amplifier are as follows.

- As there is no need of center tapped transformers, the weight and cost are reduced.
- Equal and opposite input signal voltages are not required.

Disadvantages

The disadvantages of Complementary symmetry push pull class B amplifier are as follows.

- It is difficult to get a pair of transistors (NPN and PNP) that have similar characteristics.
- We require both positive and negative supply voltages.

The class A and class B amplifier so far discussed has got few limitations. Let us now try to combine these two to get a new circuit which would have all the advantages of both class A and class B amplifier without their inefficiencies. Before that, let us also go through another important problem, called as **Cross over distortion**, the output of class B encounters with.

Cross-over Distortion:

In the push-pull configuration, the two identical transistors get into conduction, one after the other and the output produced will be the combination of both.

When the signal changes or crosses over from one transistor to the other at the zero voltage point, it produces an amount of distortion to the output wave shape. For a transistor in order to conduct, the base emitter junction should cross 0.7V , the cut off voltage. The time taken for a transistor to get ON from OFF or to get OFF from ON state is called the **transition period**.

At the zero voltage point, the transition period of switching over the transistors from one to the other, has its effect which leads to the instances where both the transistors are OFF at a time. Such instances can be called as **Flat spot** or **Dead band** on the output wave shape.

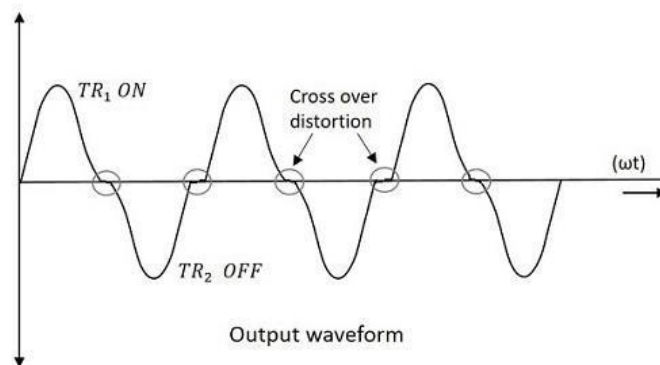

The above figure clearly shows the cross over distortion which is prominent in the output waveform. This is the main disadvantage. This cross over distortion effect also reduces the overall peak to peak value of the output waveform which in turn reduces the maximum power output. This can be more clearly understood through the non-linear characteristic of the waveform as shown below.

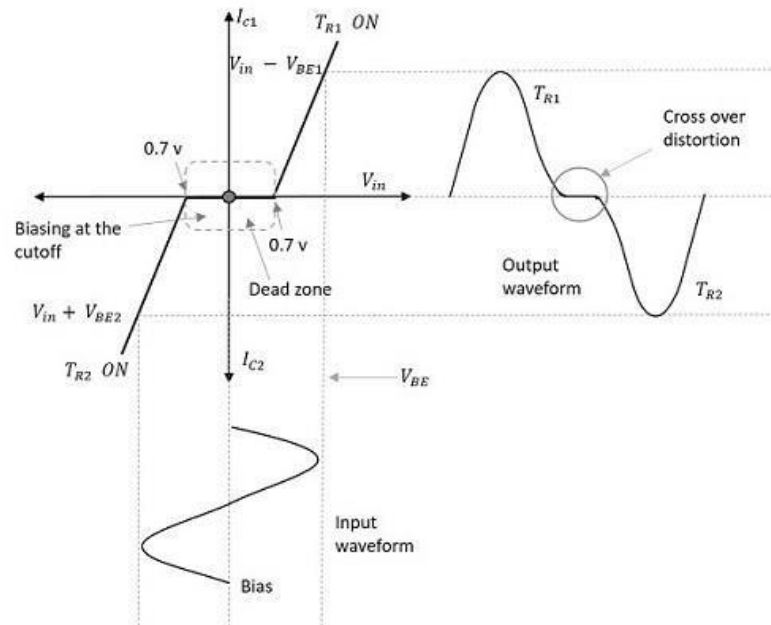

It is understood that this cross-over distortion is less pronounced for large input signals, where as it causes severe disturbance for small input signals. This cross over distortion can be eliminated if the conduction of the amplifier is more than one half cycle, so that both the transistors won't be OFF at the same time.

This idea leads to the invention of class AB amplifier, which is the combination of both class A and class B amplifiers, as discussed below.

Class AB Power Amplifier

As the name implies, class AB is a combination of class A and class B type of amplifiers. As class A has the problem of low efficiency and class B has distortion problem, this class AB is emerged to eliminate these two problems, by utilizing the advantages of both the classes.

The cross over distortion is the problem that occurs when both the transistors are OFF at the same instant, during the transition period. In order to eliminate this, the condition has to be chosen for more than one half cycle. Hence, the other transistor gets into conduction, before the operating transistor switches to cut off state. This is achieved only by using class AB configuration, as shown in the following circuit diagram.

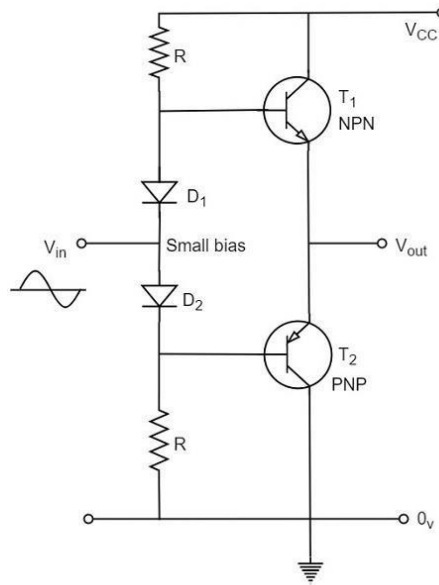

Therefore, in class AB amplifier design, each of the push-pull transistors is conducting for slightly more than the half cycle of conduction in class B, but much less than the full cycle of conduction of class A.

The conduction angle of class AB amplifier is somewhere between 180° to 360° depending upon the operating point selected. This is understood with the help of below figure.

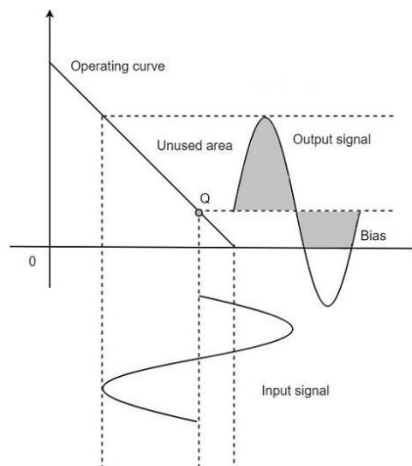

The small bias voltage given using diodes D_1 and D_2 , as shown in the above figure, helps the operating point to be above the cutoff point. Hence the output waveform of class AB results as seen in the above figure. The crossover distortion created by class B is overcome by this class AB, as well the inefficiencies of class A and B don't affect the circuit.

So, the class AB is a good compromise between class A and class B in terms of efficiency and linearity having the efficiency reaching about 50% to 60%. The class A, B and AB amplifiers are called as **linear amplifiers** because the output signal amplitude and phase are linearly related to the input signal amplitude and phase.

Class C Power Amplifier

When the collector current flows for less than half cycle of the input signal, the power amplifier is known as **class C power amplifier**. The efficiency of class C amplifier is high while linearity is poor. The conduction angle for class C is less than 180° . It is generally around 90° , which means the transistor remains idle for more than half of the input signal. So, the output current will be delivered for less time compared to the application of input signal.

The following figure shows the operating point and output of a class C amplifier.

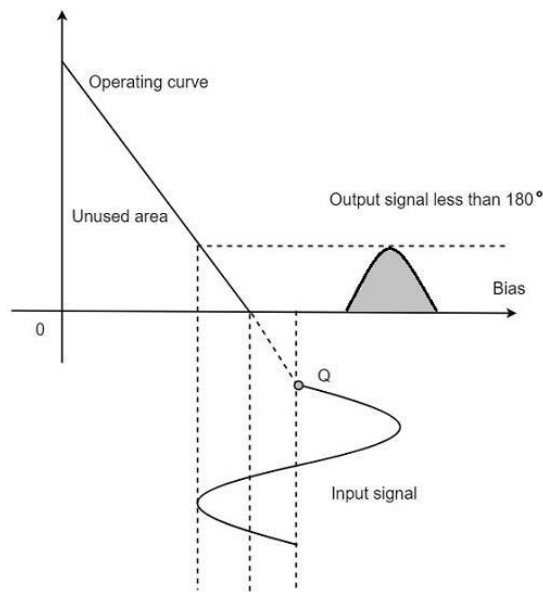

This kind of biasing gives a much improved efficiency of around 80% to the amplifier, but introduces heavy distortion in the output signal. Using the class C amplifier, the pulses produced at its output can be converted to complete sine wave of a particular frequency by using LC circuits in its collector circuit.

The types of amplifiers that we have discussed so far cannot work effectively at radio frequencies, even though they are good at audio frequencies. Also, the gain of these amplifiers is such that it will not vary according to the frequency of the signal, over a wide range. This allows the amplification of the signal equally well over a range of frequencies and does not permit the selection of particular desired frequency while rejecting the other frequencies.

UNIT-V TUNED AMPLIFIER

Tuned amplifiers are the amplifiers that are employed for the purpose of **tuning**. Tuning means selecting. Among a set of frequencies available, if there occurs a need to select a particular frequency, while rejecting all other frequencies, such a process is called **Selection**. This selection is done by using a circuit called as **Tuned circuit**.

When an amplifier circuit has its load replaced by a tuned circuit, such an amplifier can be called as a **Tuned amplifier circuit**. The basic tuned amplifier circuit looks as shown below.

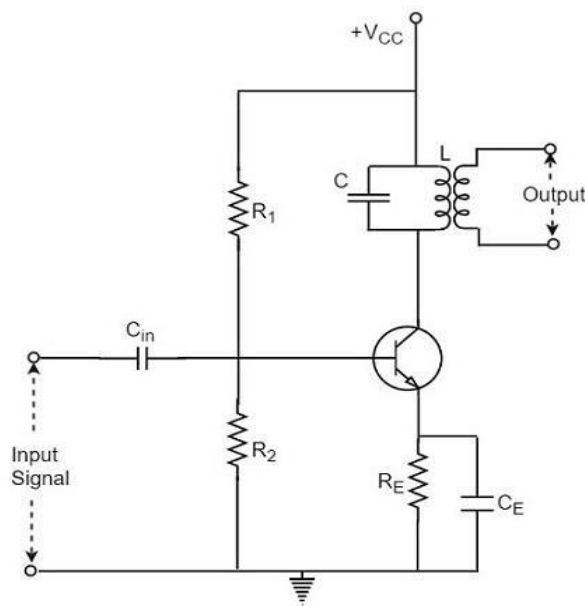

The tuner circuit is nothing but a LC circuit which is also called as **resonant** or **tank circuit**. It selects the frequency. A tuned circuit is capable of amplifying a signal over a narrow band of frequencies that are centered at resonant frequency.

When the reactance of the inductor balances the reactance of the capacitor, in the tuned circuit at some frequency, such a frequency can be called as **resonant frequency**. It is denoted by f_r .

The formula for resonance is

$$2\pi f_L = \frac{1}{2\pi f_c}$$

$$f_r = \frac{1}{2\pi\sqrt{LC}}$$

Types of Tuned Circuits

A tuned circuit can be Series tuned circuit (Series resonant circuit) or Parallel tuned circuit (parallel resonant circuit) according to the type of its connection to the main circuit.

Series Tuned Circuit

The inductor and capacitor connected in series make a series tuned circuit, as shown in the following circuit diagram.



At resonant frequency, a series resonant circuit offers low impedance which allows high current through it. A series resonant circuit offers increasingly high impedance to the frequencies far from the resonant frequency.

Parallel Tuned Circuit

The inductor and capacitor connected in parallel make a parallel tuned circuit, as shown in the below figure.

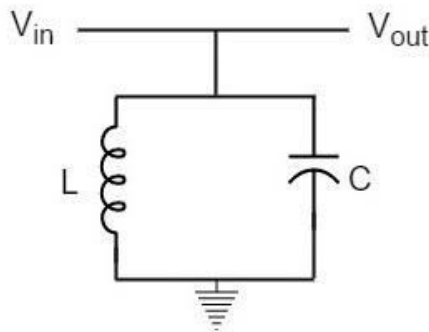

At resonant frequency, a parallel resonant circuit offers high impedance which does not allow high current through it. A parallel resonant circuit offers increasingly low impedance to the frequencies far from the resonant frequency.

Characteristics of a Parallel Tuned Circuit

The frequency at which parallel resonance occurs (i.e. reactive component of circuit current becomes zero) is called the resonant frequency f_r . The main characteristics of a tuned circuit are as follows.

Impedance

The ratio of supply voltage to the line current is the impedance of the tuned circuit. Impedance offered by LC circuit is given by

$$\text{Supply voltage / Line equation} = V / I$$

At resonance, the line current increases while the impedance decreases. The below figure represents the impedance curve of a parallel resonance circuit.

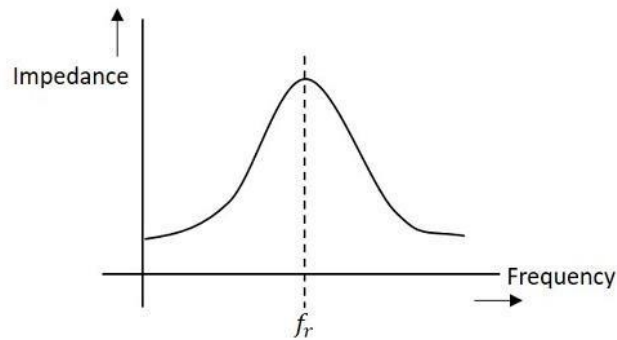

Impedance of the circuit decreases for the values above and below the resonant frequency f_r . Hence the selection of a particular frequency and rejection of other frequencies is possible.

To obtain an equation for the circuit impedance, let us consider

Line Current $I = I_L \cos \phi$

$$V/Z_r = V/Z_L \times R/Z_L$$

$$1/Z_r = R/Z_L^2$$

$$1/Z_r = CR/L$$

Since, $Z_L = L/C$

Therefore, circuit impedance Z_r is obtained as

$$Z_r = L/CR$$

Thus at parallel resonance, the circuit impedance is equal to L/CR .

Circuit Current

At parallel resonance, the circuit or line current I is given by the applied voltage divided by the circuit impedance Z_r i.e.,

$$\text{Line Current } I = V/Z_r$$

$$\text{Where } Z_r = L/CR$$

Because Z_r is very high, the line current I will be very small.

Quality Factor

For a parallel resonance circuit, the sharpness of the resonance curve determines the selectivity. The smaller the resistance of the coil, the sharper the resonant curve will be. Hence the inductive reactance and resistance of the coil determine the quality of the tuned circuit.

The ratio of inductive reactance of the coil at resonance to its resistance is known as **Quality factor**. It is denoted by **Q**.

$$Q = X_L/R = 2\pi f_r L/R$$

The higher the value of Q , the sharper the resonance curve and the better the selectivity will be.

Advantages of Tuned Amplifiers

The following are the advantages of tuned amplifiers.

- The usage of reactive components like L and C, minimizes the power loss, which makes the tuned amplifiers efficient.
- The selectivity and amplification of desired frequency is high, by providing higher impedance at resonant frequency.
- A smaller collector supply VCC would do, because of its little resistance in parallel tuned circuit.

It is important to remember that these advantages are not applicable when there is a high resistive collector load.

Frequency Response of Tuned Amplifier

For an amplifier to be efficient, its gain should be high. This voltage gain depends upon β , input impedance and collector load. The collector load in a tuned amplifier is a tuned circuit.

The voltage gain of such an amplifier is given by

$$\text{Voltage gain} = \beta Z_c / Z_{in}$$

Where Z_c = effective collector load and Z_{in} = input impedance of the amplifier.

The value of Z_c depends upon the frequency of the tuned amplifier. As Z_c is maximum at resonant frequency, the gain of the amplifier is maximum at this resonant frequency.

Bandwidth

The range of frequencies at which the voltage gain of the tuned amplifier falls to 70.7% of the maximum gain is called its **Bandwidth**. The range of frequencies between f_1 and f_2 is called as bandwidth of the tuned amplifier. The bandwidth of a tuned amplifier depends upon the Q of the LC circuit i.e., upon the sharpness of the frequency response. The value of Q and the bandwidth are inversely proportional.

The figure below details the bandwidth and frequency response of the tuned amplifier.

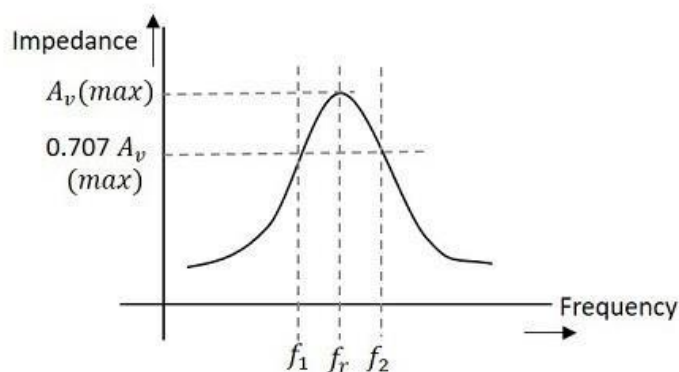

Relation between Q and Bandwidth

The quality factor Q of the bandwidth is defined as the ratio of resonant frequency to bandwidth, i.e.,

$$Q = f_r / BW$$

In general, a practical circuit has its Q value greater than 10.

Under this condition, the resonant frequency at parallel resonance is given by

$$f_r = 1/\sqrt{2\pi LC}$$

There are two main types of tuned amplifiers. They are –

- Single tuned amplifier
- Double tuned amplifier

Single Tuned Amplifier

An amplifier circuit with a single tuner section being at the collector of the amplifier circuit is called as Single tuner amplifier circuit.

Construction

A simple transistor amplifier circuit consisting of a parallel tuned circuit in its collector load, makes a single tuned amplifier circuit. The values of capacitance and inductance of the tuned circuit are selected such that its resonant frequency is equal to the frequency to be amplified.

The following circuit diagram shows a single tuned amplifier circuit.

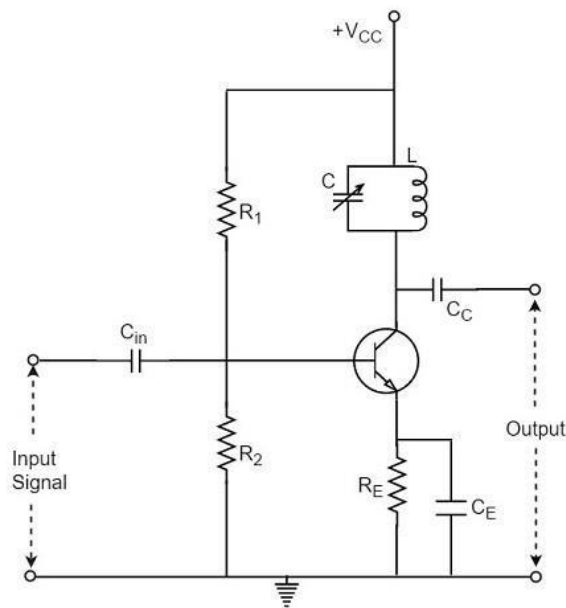

The output can be obtained from the coupling capacitor C_c as shown above or from a secondary winding placed at L.

Operation

The high frequency signal that has to be amplified is applied at the input of the amplifier. The resonant frequency of the parallel tuned circuit is made equal to the frequency of the signal applied by altering the capacitance value of the capacitor C, in the tuned circuit. At this stage, the tuned circuit offers high impedance to the signal frequency, which helps to offer high output across the tuned circuit. As high impedance is offered only for the tuned frequency, all the other frequencies which get lower impedance are rejected

by the tuned circuit. Hence the tuned amplifier selects and amplifies the desired frequency signal.

Frequency Response

The parallel resonance occurs at resonant frequency f_r when the circuit has a high Q. the resonant frequency f_r is given by

$$f_r = 1/\sqrt{2\pi LC}$$

The following graph shows the frequency response of a single tuned amplifier circuit.

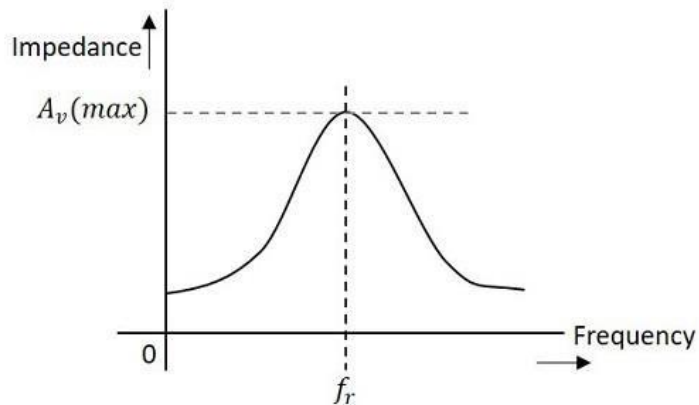

At resonant frequency f_r the impedance of parallel tuned circuit is very high and is purely resistive. The voltage across R_L is therefore maximum, when the circuit is tuned to resonant frequency. Hence the voltage gain is maximum at resonant frequency and drops off above and below it. The higher the Q, the narrower will the curve be.

Double Tuned Amplifier

An amplifier circuit with a double tuner section being at the collector of the amplifier circuit is called as Double tuner amplifier circuit.

Construction

The construction of double tuned amplifier is understood by having a look at the following figure. This circuit consists of two tuned circuits L_1C_1 and L_2C_2 in the collector section of the amplifier. The signal at the output of the tuned circuit L_1C_1 is coupled to the other tuned circuit L_2C_2 through mutual coupling method. The remaining circuit details are same as in the single tuned amplifier circuit, as shown in the following circuit diagram.

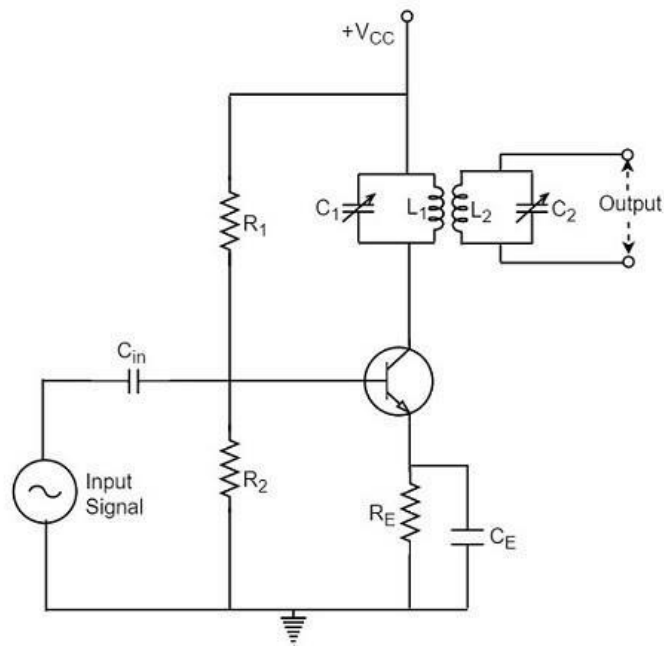

Operation

The high frequency signal which has to be amplified is given to the input of the amplifier. The tuning circuit L_1C_1 is tuned to the input signal frequency. At this condition, the tuned circuit offers high reactance to the signal frequency. Consequently, large output appears at the output of the tuned circuit L_1C_1 which is then coupled to the other tuned circuit L_2C_2 through mutual induction. These double tuned circuits are extensively used for coupling various circuits of radio and television receivers.

Frequency Response of Double Tuned Amplifier

The double tuned amplifier has the special feature of **coupling** which is important in determining the frequency response of the amplifier. The amount of mutual inductance between the two tuned circuits states the degree of coupling, which determines the frequency response of the circuit.

In order to have an idea on the mutual inductance property, let us go through the basic principle.

Mutual Inductance

As the current carrying coil produces some magnetic field around it, if another coil is brought near this coil, such that it is in the magnetic flux region of the primary, then the varying magnetic flux induces an EMF in the second coil. If this first coil is called as **Primary coil**, the second one can be called as a **Secondary coil**. When the EMF is induced in the secondary coil due to the varying magnetic field of the primary coil, then such phenomenon is called as the

Mutual Inductance.

The figure below gives an idea about this.

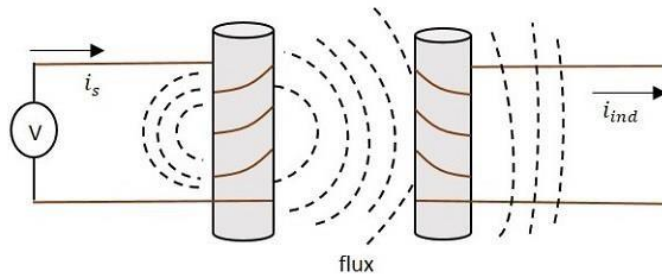

The current i_s in the figure indicates the source current while i_{ind} indicates the induced current. The flux represents the magnetic flux created around the coil. This spreads to the secondary coil also. With the application of voltage, the current i_s flows and flux gets created. When the current varies the flux gets varied, producing i_{ind} in the secondary coil, due to the Mutual inductance property.

Coupling

Under the concept of mutual inductance coupling will be as shown in the figure below.

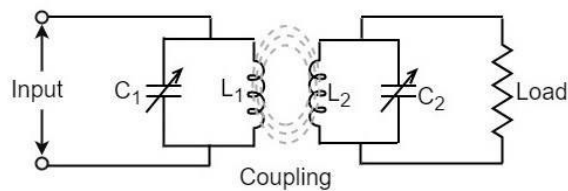

When the coils are spaced apart, the flux linkages of primary coil L_1 will not link the secondary coil L_2 . At this condition, the coils are said to have **Loose coupling**. The resistance reflected from the secondary coil at this condition is small and the resonance curve will be sharp and the circuit Q is high as shown in the figure below.

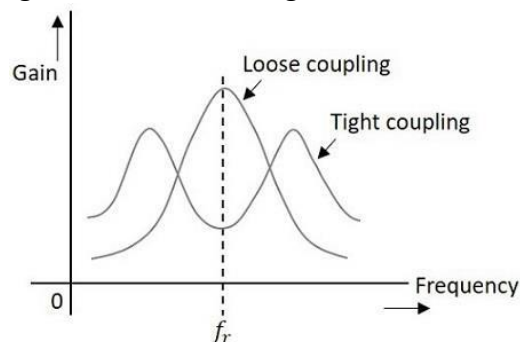

On the contrary, when the primary and secondary coils are brought close together, they have **Tight coupling**. Under such conditions, the reflected resistance will be large and the circuit Q is lower. Two positions of gain maxima, one above and the other below the resonant frequency are obtained.

Bandwidth of Double Tuned Circuit

The above figure clearly states that the bandwidth increases with the degree of coupling. The determining factor in a double tuned circuit is not Q but the coupling. We understood that, for a given frequency, the tighter the coupling the greater the bandwidth will be.

The equation for bandwidth is given as

$$BW_{dt} = k f_r$$

Where BW_{dt} = bandwidth for double tuned circuit, K = coefficient of coupling, and f_r = resonant frequency.