

Chapter 4: Bipolar Junction Transistors (BJTs)

Bipolar Junction Transistor (BJT) Structure

The BJT is constructed with three doped semiconductor regions separated by two pn junctions, as in Figure 1(a). The three regions are called *emitter*, *base*, and *collector*. Physical representations of the two types of BJTs are shown in Figure 1(b) and (c). One type consists of two n regions separated by a p region (nnp), and the other type consists of two p regions separated by an n region ($pnnp$). The term **bipolar** refers to the use of both holes and electrons as current carriers in the transistor structure. This mode of operation is contrasted with unipolar transistors, such as *field-effect transistors*, in which only one carrier type is employed (electron or hole, ex: diode).

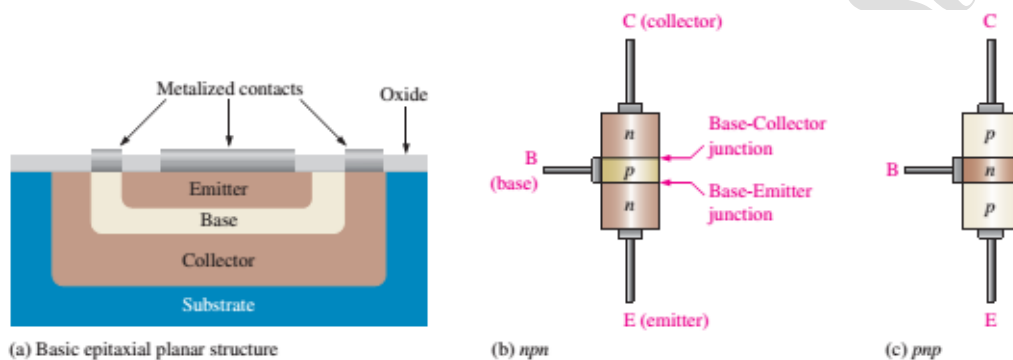

Figure 1: Basic BJT construction.

The pn junction joining the base region and the emitter region is called the *base-emitter junction*. The pn junction joining the base region and the collector region is called the *base-collector junction*. A wire lead connects to each of the three regions. These leads are labeled E for emitter, B for base and C for collector. The base region is lightly doped and very thin compared to the heavily doped emitter and the moderately doped collector regions. Figure 2 shows the symbols for the nnp and $pnnp$ bipolar junction transistors.

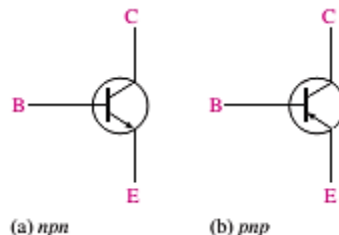

Figure 2: Standard BJT symbols.

BJT Biasing

In order for a BJT to operate properly as an amplifier, the two pn junctions must be correctly biased with external dc voltages. Figure 3 shows a bias arrangement for both nnp and $pnnp$ BJTs for operation as an **amplifier**. In both cases, the base-emitter (BE)

junction is forward-biased and the base-collector (BC) junction is reverse-biased. This condition is called *forward-reverse bias*. For the npn type shown, the collector is more positive than the base, which is more positive than the emitter. For the pnp type, the voltages are reversed to maintain the forward-reverse bias.

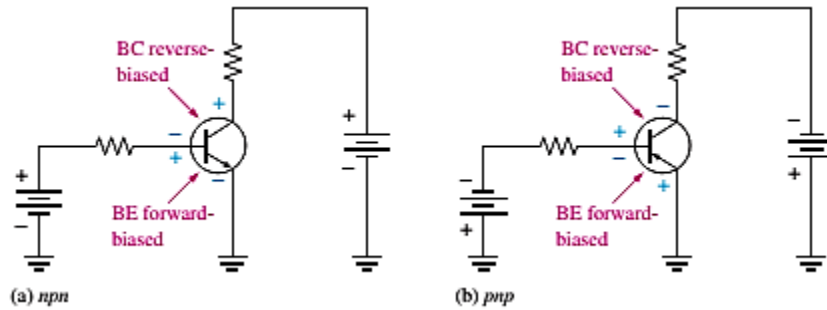

Figure 3: Forward-reverse bias of a BJT.

The heavily doped n-type emitter region has a very high density of conduction-band (free) electrons as indicated in Figure 4. These free electrons easily diffuse through the forward biased BE junction into the lightly doped and very thin p-type base region. The base has a low density of holes, which are the majority carriers, as represented by the white circles.

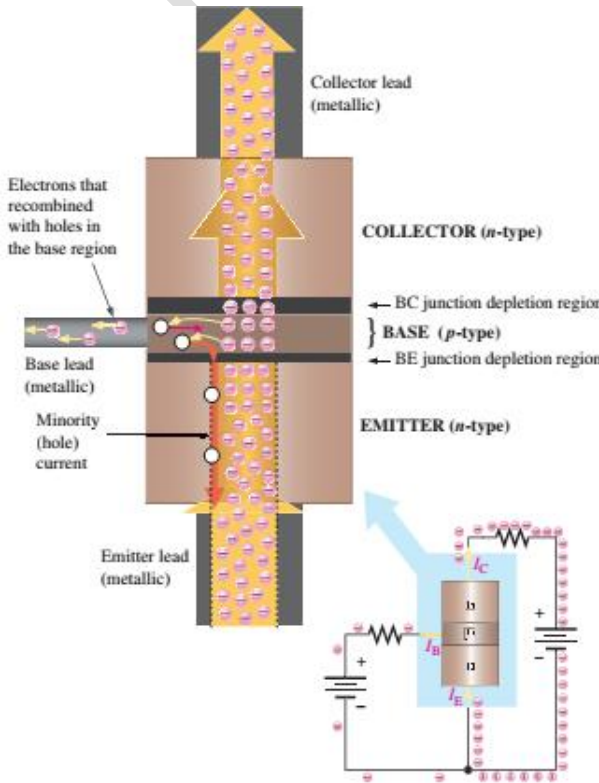

Figure 4: BJT operation showing electron flow.

A very little free electron recombine with holes in base and move as valence electrons through the base region and into the emitter region as hole current. The valence electrons leave the crystalline structure of the base, become free electrons in the metallic

base lead, and produce the external base current. Majority of free electrons move toward the reverse-biased BC junction and swept across into the collector region by the attraction of the positive collector supply voltage. The free electrons move through the collector region, into the external circuit, and then return into the emitter region along with the base current.

Transistor Currents

The conventional current flows in the direction of the arrow on the emitter terminal. The emitter current (I_E) is the sum of the collector current (I_C) and the small base current (I_B). That is,

$$I_E = I_C + I_B$$

I_B is very small compared to I_E or I_C . The capital-letter subscripts indicate dc values. The voltage drop between base and emitter is V_{BE} whereas the voltage drop between collector and base is called V_{CB} .

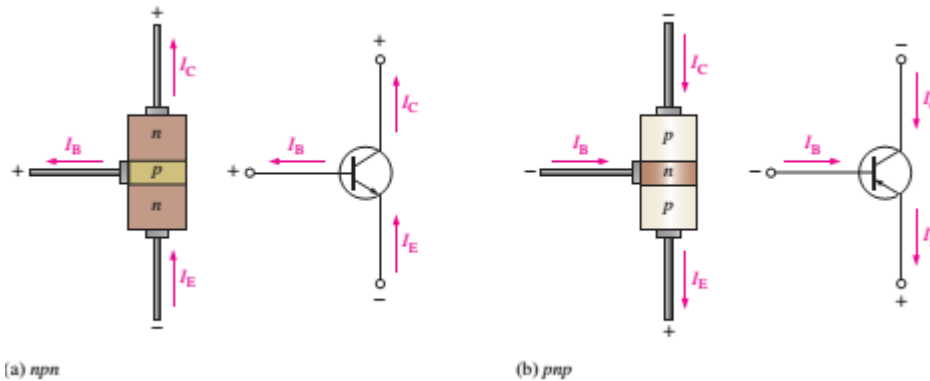

Figure 5: Transistor currents.

BJT Characteristics and Parameters

Two important parameters, β_{DC} (*dc current gain*) and α_{DC} are used to analyze a BJT circuit. When a transistor is connected to dc bias voltages, as shown in Figure 6 for both *npn* and *pnp* types, V_{BB} forward-biases the base-emitter junction, and V_{CC} reverse-biases the base-collector junction.

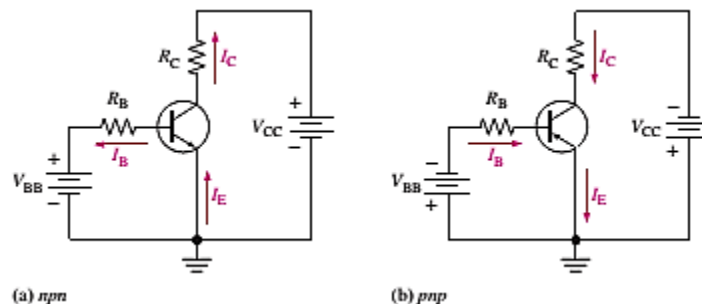

Figure 6: Transistor dc bias circuits.

The collector current is directly proportional to the base current.

$$I_C \propto I_B$$

The β_{DC} of a transistor is the ratio of the dc collector current (I_C) to the dc base current (I_B).

$$\beta_{DC} = \frac{I_C}{I_B}$$

This equation explains **amplification of current**.

The ratio of the dc collector current (I_C) to the dc emitter current (I_E) is the (α_{DC}).

$$\alpha_{DC} = \frac{I_C}{I_E}$$

α_{DC} is always less than 1

Example: Determine the dc current gain β_{DC} and the emitter current I_E for a transistor where $I_B=50\mu\text{A}$ and $I_C= 3.65 \text{ mA}$.

Solution

$$\beta_{DC} = \frac{I_C}{I_B} = \frac{3.65 \text{ mA}}{50 \mu\text{A}} = 73$$

$$I_E = I_C + I_B = 3.65 \text{ mA} + 50\mu\text{A} = 3.70 \text{ mA}$$

BJT Circuit Analysis

Consider the basic transistor bias circuit configuration in Figure 7. Three transistor dc currents and three dc voltages can be identified.

I_B : dc base current

I_E : dc emitter current

I_C : dc collector current

V_{BE} : dc voltage across base-emitter junction

V_{CE} : dc voltage across collector-emitter junction

V_{CB} : dc voltage across collector-base junction

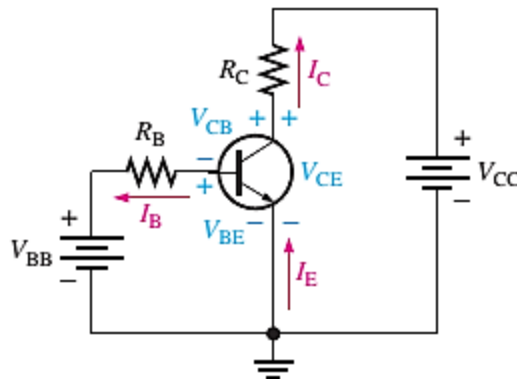

Figure 7: Transistor currents and voltages.

When the base-emitter junction is forward-biased, it is like a forward-biased diode and has a forward voltage drop of $V_{BE} \cong 0.7 \text{ V}$

The voltage at the collector with respect to the grounded emitter is

$$V_{CE} = V_{CC} - I_C R_C \quad (I_C R_C = V_{RC})$$

The current across I_B is

$$I_B = \frac{V_{BB} - V_{BE}}{R_B} \quad (I_B R_B = V_{R_B})$$

The voltage across the reverse-biased collector-base junction is

$$V_{CB} = V_{CE} - V_{BE}$$

Example: Determine I_B , I_C , I_E , V_{BE} , V_{CE} , and V_{CB} in the circuit of following Figure. The transistor has a $\beta_{DC} = 150$.

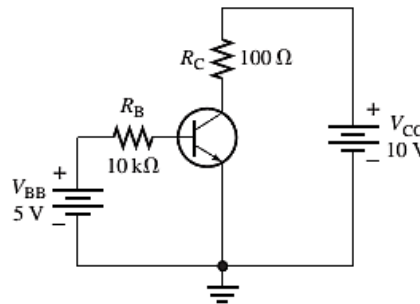

Solution:

$V_{BE} \cong 0.7 \text{ V}$, Calculate the base, collector, and emitter currents as follows:

$$I_B = \frac{V_{BB} - V_{BE}}{R_B} = \frac{5 \text{ V} - 0.7 \text{ V}}{10 \text{ k}\Omega} = 430 \mu\text{A}$$

$$I_C = \beta_{DC} I_B = (150)(430 \mu\text{A}) = 64.5 \text{ mA}$$

$$I_E = I_C + I_B = 64.5 \text{ mA} + 430 \mu\text{A} = 64.9 \text{ mA}$$

Solve for V_{CE} and V_{CB} .

$$V_{CE} = V_{CC} - I_C R_C = 10 \text{ V} - (64.5 \text{ mA})(100 \Omega) = 10 \text{ V} - 6.45 \text{ V} = 3.55 \text{ V}$$

$$V_{CB} = V_{CE} - V_{BE} = 3.55 \text{ V} - 0.7 \text{ V} = 2.85 \text{ V}$$

Since the collector is at a higher voltage than the base, the CB junction is reverse-biased.

Collector Characteristic Curves

The collector characteristic curves shows three mode of operations of transistor with the variation of collector current I_C varies with the V_{CE} for a specified value of base current I_B . Assume that V_{BB} is set to produce a certain value of I_B and V_{CC} is zero and V_{CE} is zero. As V_{CE} is increased, I_C increases until B. When both BE and BC junctions are forward biased and the transistor is in saturation region. In saturation, an increase of base current has no effect on the collector current and the relation $I_C = \beta_{DC} I_B$ is no longer valid.

$$I_{C(SAT)} = \frac{V_{CC} - V_{CE(SAT)}}{R_C}$$

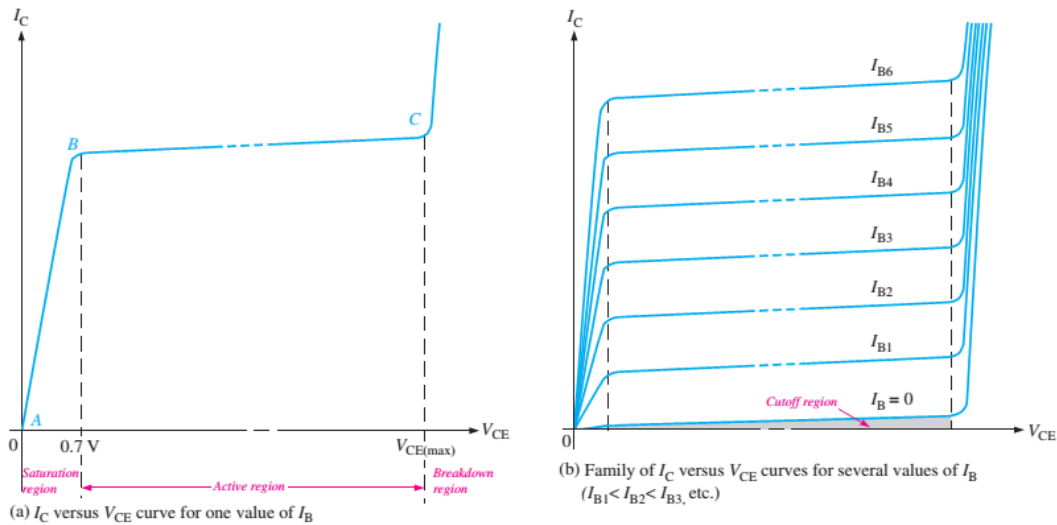

Figure 8: Collector characteristic curves.

At this point, the transistor current is maximum and voltage across collector is minimum, for a given load.

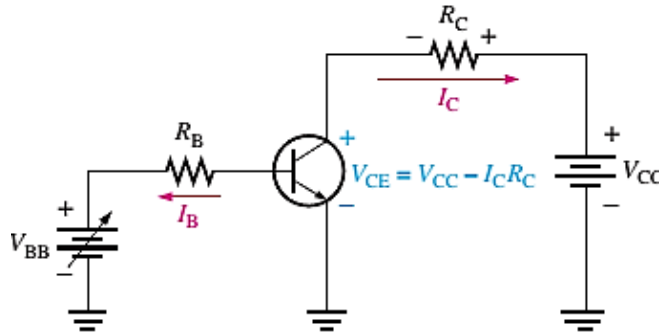

Figure 9: Base-emitter and base-collector junctions are forward-biased.

When V_{CE} is increased further and exceeds 0.7V, the base-collector junction becomes reverse-biased and the transistor goes into the **active**, or **linear**, region of its operation. I_C levels off and remains essentially constant for a given value of I_B as V_{CE} continues to increase. The value of I_C is determined only by the relationship expressed as $I_C = \beta_{DC} I_B$.

A family of collector characteristic curves is produced when I_C versus V_{CE} is plotted for several values of I_B , as illustrated in Figure 8(b). It can be read from the curves. The value of β_{DC} is nearly the same wherever it is read in active region. In a BJT, **cutoff** is the condition in which there is no base current ($I_B = 0$), which results in only an extremely small leakage current (I_{CEO}) in the collector circuit. The subscript CEO represents collector to-emitter with the base open. For practical work, this current is assumed to be zero. In cutoff, neither the BE junction, nor the BC junction are forward-biased.

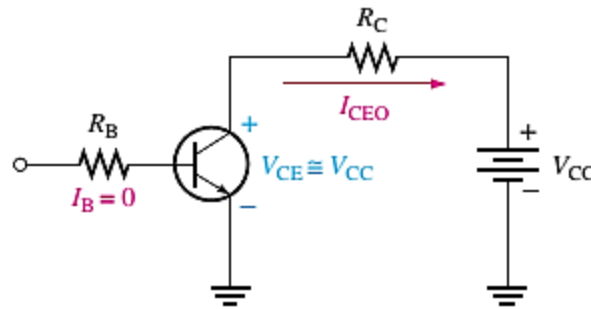
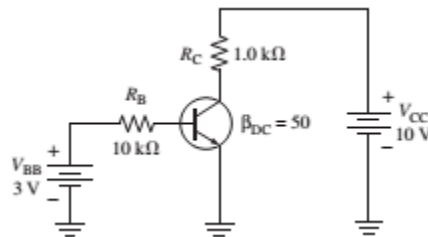

Figure 10: Cutoff: Base-emitter and base-collector junctions are reverse-biased.

Example: Determine whether or not the transistor in following figure is in saturation.

Assume $V_{CE(sat)} = 0.2V$.



Solution:

First, determine $I_{C(sat)}$.

$$I_{C(sat)} = \frac{V_{CC} - V_{CE(sat)}}{R_C} = \frac{10V - 0.2V}{1.0k\Omega} = \frac{9.8V}{1.0k\Omega} = 9.8mA$$

Now, see if I_B is large enough to produce $I_{C(sat)}$.

$$I_B = \frac{V_{BB} - V_{BE}}{R_B} = \frac{3V - 0.7V}{10k\Omega} = \frac{2.3V}{10k\Omega} = 0.23mA$$

$$I_C = \beta_{DC} I_B = (50)(0.23mA) = 11.5mA$$

This shows that with the specified β_{DC} , this base current is capable of producing an I_C greater than $I_{C(sat)}$. Therefore, the **transistor is saturated**.

The BJT as a Switch

A BJT can be used as a switching device in logic circuits to turn on or off current to a load. As a switch, the transistor is normally in either cutoff (load is OFF) or saturation (load is ON).

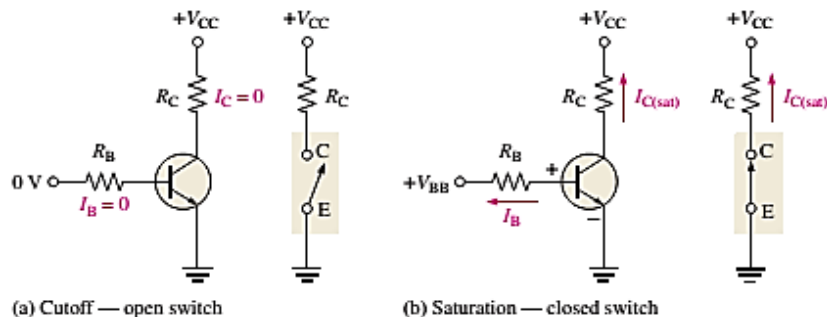

Figure 11: Switching action of an ideal transistor.

DC Load Line

Figure 12 shows a dc load line the cutoff point and the saturation point. The bottom of the load line is at ideal cutoff where $I_C=0$ and $V_{CE}=V_{CC}$. The top of the load line is at saturation where $I_C=I_{C(sat)}$ and $V_{CE}=V_{CE(sat)}$. In between cutoff and saturation along the load line is the *active region* of the transistor's operation

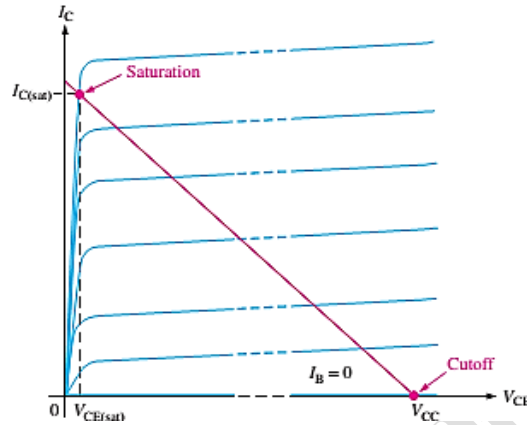

Figure 12.

The BJT as an Amplifier

Amplification is the process of increasing the power, voltage, or current by electronic means and is one of the major properties of a transistor. As you learned, a BJT exhibits current gain (called β). When a BJT is biased in the active (or linear) region, the BE junction has a low resistance due to forward bias and the BC junction has a high resistance due to reverse bias.

The DC Operating Point

Bias establishes the operating point (Q -point) of a transistor amplifier; the ac signal moves above and below this point. If an amplifier is not biased with correct dc voltages on the input and output, it can go into saturation or cutoff when an input signal is applied. Improper biasing can cause distortion in the output signal.

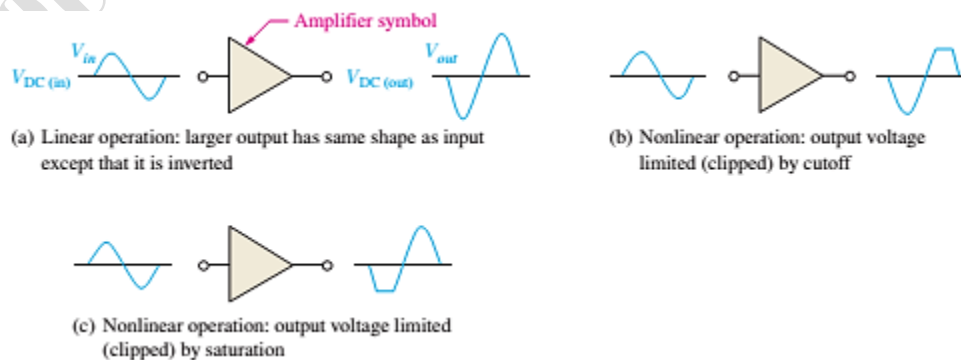

Figure 13: Examples of linear and nonlinear operation of an inverting amplifier.

developed by a resistive voltage divider that consists of R_1 and R_2 , as in Figure 16. R_1 and R_2 are selected to establish V_B . If the divider is *stiff*, I_B is small compared to I_2 .

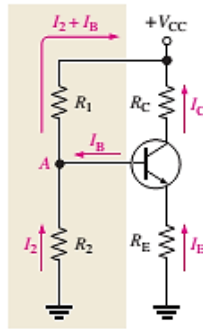

Figure 16: Voltage-divider bias.

To analyze a voltage-divider circuit in which I_B is small compared to I_2 , first calculate the voltage on the base:

$$V_B \cong \left(\frac{R_2}{R_1 + R_2} \right) V_{CC}$$

Once you know the base voltage, you can find the voltages and currents in the circuit, as follows:

$$V_E = V_B - V_{BE}$$

And

$$I_C \cong I_E = \frac{V_E}{R_E}$$

Then

$$V_C = V_{CC} - I_C R_C$$

Once you know V_C and V_E , you can determine V_{CE} .

$$V_{CE} = V_C - V_E$$

A practical biasing technique that utilize single biasing sources instead of separate V_{CC} and V_{BB} . A dc bias voltage at the base of the transistor can be developed by a resistive voltage divider that consists of R_1 and R_2 .

H.W: Determine V_{CE} and I_C in the stiff voltage-divider biased transistor circuit of the following figure if $\beta_{DC}=100$.

Answer: $I_C=5.16\text{mA}$, $V_{CE}=1.95\text{V}$

