

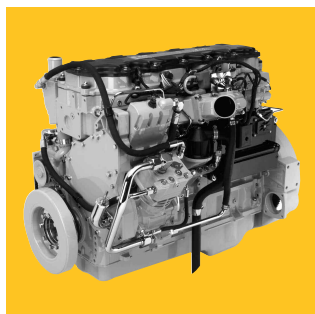

C7 ACERT™



C9 ACERT



C11 ACERT

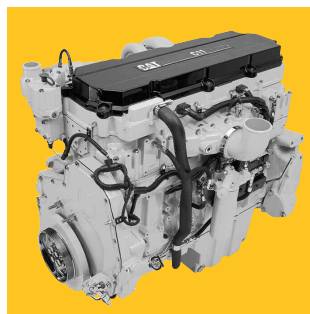

C13 ACERT



C7-C32 ACERT™ INDUSTRIAL ENGINE electronics application & installation guide

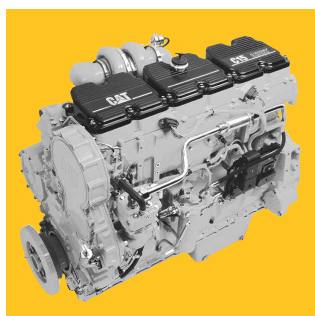

C15 ACERT

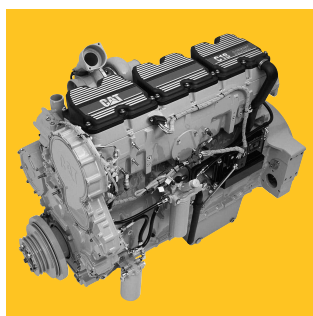

C18 ACERT

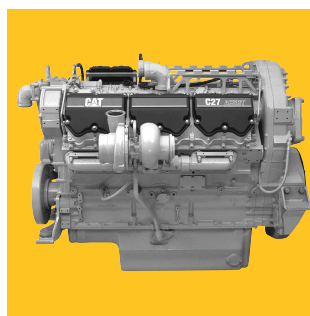

C27 ACERT



C32 ACERT

INDUSTRIAL

C7 (JTF: 100-up)	C13 (LGK: 100-up)
C7 (JRA: 100-up)	C15 (JRE: 100-up)
C9 (JSC: 100-up)	C18 (WJH: 100-up)
C9 (MBD: 100-up)	C27 (TWM: 100-up)
C11 (GLS: 100-up)	C32 (TLD: 100-up)

PETROLEUM

C7 (C7P: 100-up)
C7 (P9L: 100-up)
C18 (MPE: 100-up)
C32 (SMP: 100-up)

Doosan purchased Bobcat Company from Ingersoll-Rand Company in 2007. Any reference to Ingersoll-Rand Company or use of trademarks, service marks, logos, or other proprietary identifying marks belonging to Ingersoll-Rand Company in this manual is historical or nominative in nature, and is not meant to suggest a current affiliation between Ingersoll-Rand Company and Doosan Company or the products of either.

1	Introduction and Purpose	4
1.1	Safety	4
1.2	Replacement Parts	5
2	Engine System Overview	6
2.1	Electronic Engine Control	6
2.2	Factory Configuration Parameters	7
2.3	Engine Component Overview	8
2.4	Engine Component Locations (TBC)	11
2.5	Engine System Diagrams	12
3	Customer System Overview	15
3.1	Customer Configuration Parameters	15
3.2	Customer Component Overview	15
4	Power and Grounding Considerations	18
4.1	Power Requirements	18
4.2	Engine Grounding	21
4.3	Air Starter Equipped Vehicles	22
4.4	Sensor Common Connections	23
4.5	Suppression of Voltage Transients	23
4.6	Battery Disconnect Switch	24
5	Connectors and Wiring Harness Requirements	25
5.1	Wiring Harness Components	25
5.2	Wiring Harness Design	32
5.3	Service Tool Connector (J66) Wiring	36
5.4	SAE J1939/11 — Data Bus Wiring	37
6	Customer Equipment I.D. and Passwords	40
6.1	Equipment Identification	40
6.2	Customer Passwords	40
6.3	Parameter Lockout	41
7	Factory Configured Parameters	42
7.1	Engine Serial Number	42
7.2	Rating Number	42
7.3	FLS (Full Load Setting)	43
7.4	FTS (Full Torque Setting)	43
8	Customer-Installed Sensors	44
8.1	Coolant Level Sensor	44
8.2	Auxiliary Pressure Sensor	46
8.3	Auxiliary Temperature Sensor	47
9	Starting and Stopping the Engine	49
9.1	Remote Shutdown Switch	49
9.2	Air Shutoff System	50
9.3	Wait-to-Start	51
10	Exhaust and Compression Brakes	52
10.1	Compression Brake (Available on C15 and C18 Only)	52
10.2	Exhaust Brake (Available on C7 and C9 Only)	54

11 Engine Speed Demand	57
11.1 Throttle Position Sensor (TPS)	57
11.2 Dual Throttle Position Sensors	60
11.3 Intermediate Engine Speed	60
11.4 J1939 Speed Control (TSC1) (Data Link Command)	61
11.5 Power Take Off (PTO) Ramp Up/Down Mode	62
11.6 PTO Set/Resume Mode	64
11.7 ET Override (Dyno Test Mode)	66
11.8 Low Idle Speed	66
11.9 Top Engine Limit (TEL)	66
11.10 High Idle Speed	67
11.11 Engine Acceleration Rate	69
11.12 Throttle Arbitration Strategy	69
12 Torque Limiting	71
12.1 Torque Limit Switch	71
13 Engine Governor	72
13.1 Full Range Engine Speed Governor	73
13.2 Min/Max Governor	76
14 Load Calculations	78
14.1 Load Factor	78
14.2 Percent Load	78
15 Engine Monitoring and Protection	79
15.1 Engine Monitoring Parameters	81
15.2 Engine Monitoring Lamps	93
15.3 Engine Monitoring System Tests	95
15.4 Engine Maintenance Indicator	96
16 Cold Starting Aid	98
16.1 Third Party Supplied Ether Injection Systems	98
16.2 Continuous Flow Ether Starting Aid System (C11-C32 Engines Only)	98
16.3 Air Inlet Heater (C7 and C9 Engines Only)	99
16.4 Starting Aid Selection Strategy (C7 and C9 Engines Only)	102
17 Operator Display	103
17.1 Industrial Messenger	103
18 Data Link Support	104
18.1 SAE J1939	104
18.2 Caterpillar Data Link	124
18.3 Other Data Link Standards	124
A Appendix	125
A1 ECU Interface Requirements	125
A2 ECU Connector (J1/P1) Pinout & Load Table	129
A3 Customer Harness Connector (J61/P61) Pinout Table	130
A4 Customer Configuration Parameter Table	131
A5 Customer Configuration Parameter Worksheet	132
A6 Engine Monitoring System Parameter Table	133
A7 Switch Specifications	134
A8 Installation Checklist	134
A9 Reference Media Numbers	135

1 Introduction and Purpose

This document is intended to provide the necessary information for correct installation of the following Caterpillar® Industrial engines into off-highway engine applications: C7/C9, C11/C13, C15/C18, C27/C32.

Engines covered by this publication have an ADEM™ A4 ECU.

NOTE: *The information in this document is subject to change as engine feature requirements are revised and software continues to be developed. In addition, some of the features described in this document are not yet released.*

The information in this document is the property of Caterpillar Inc. and/or its subsidiaries. Without written permission, any copying, transmission to others, and any use except that for which it is loaned is prohibited.

Contact the Electronic Applications Team via ApplicationSupport@Cat.com for the latest information on software feature release dates.

1.1 Safety

Most accidents that involve product operation, maintenance, and repair are caused by failure to observe basic safety rules or precautions. An accident can often be avoided by recognizing potentially hazardous situations before an accident occurs. A person must be alert to potential hazards. This person should also have the necessary training, skills, and tools in order to perform these functions properly.

The information in this publication was based upon current information at the time of publication. Check for the most current information before you start any job. Caterpillar dealers will have the most current information.

Improper operation, maintenance, or repair of this product may be dangerous. Improper operation, maintenance, or repair of this product may result in injury or death.

Do not operate or perform any maintenance or repair on this product until you have read and understood the operation, maintenance, and repair information.

Caterpillar cannot anticipate every possible circumstance that might involve a potential hazard. The warnings in this publication and on the product are not all inclusive. If a tool, a procedure, a work method, or an operating technique that is not specifically recommended by Caterpillar is used, you must be sure that it is safe for you and for other people. You must also be sure that the product will not be damaged. You must also be sure that the product will not be made unsafe by the procedures that are used.

1.1.1 Welding

WARNING — Welding on a Machine with an Electronic Engine:

Before welding on a vehicle equipped with an electronic engine, the following precautions should be observed.

- Turn the engine OFF.
- Place the ignition key switch in the OFF position.
- Disconnect the negative battery cable from the battery. If the vehicle is equipped with a battery disconnect switch, open the switch.
- **DO NOT** use electrical components in order to ground the welder. Do not use the ECU or sensors or any other electronic component in order to ground the welder.

For more information, refer to Appendix 9 of this document. Appendix 9 provides all relevant engine model Operation and Maintenance Manual and Troubleshooting Guide media numbers. Further information with regard to welding on a machine with an electronic engine is found in these documents.

1.2 Replacement Parts

When replacement parts are required for this product, Caterpillar recommends using Caterpillar replacement parts or parts with equivalent specifications including, but not limited to, physical dimensions, type, strength, and material.

Failure to heed this warning can lead to premature failures, product damage, personal injury, or death.

2 Engine System Overview

All of the engines covered in this document are designed for electronic control. The electronic engine control system consists of the following primary components: Electronic Control Unit (ECU), electronically controlled unit injectors, engine wiring harness, and sensors. The following sections will provide information to better understand the function of the components in the engine control system and basic understanding of electronic engine control.

2.1 Electronic Engine Control

The electronic engine control strategy determines the timing and amount of fuel that is delivered to each cylinder based on the actual and desired conditions at any given time. The objective of the control system is to deliver best performance within emission and engine operating limits. Following are the primary functions performed by the electronic engine control strategy:

2.1.1 Engine Governing

The engine governor determines how much fuel to deliver to each cylinder to respond to changes in operator demand or engine load conditions. Two governing strategies are available: Speed Governor and Min/Max Governor. Governor strategy is selectable through a programmable parameter. Refer to Engine Governor (section 13) for additional information.

2.1.2 Air to Fuel Ratio Control

The control system has full authority over engine fuel delivery. The mechanical fuel/air ratio control is eliminated on an electronically controlled engine. Electronic control of the fuel/air ratio provides optimum performance while limiting emissions.

2.1.3 Injection Timing Control

Injection timing is varied as a function of engine operating conditions to optimize engine performance for emissions, noise, fuel consumption, and driveability.

2.1.4 Torque Rise Shaping

Electronic controls provide increased flexibility to tailor the torque curve over a wide speed range.

2.1.5 Cold Starting Strategy

Before and during cranking, the engine monitors atmospheric pressure, air inlet temperature, and/or coolant temperature. Based on these inputs, the engine executes a complex cold starting strategy that adjusts fuel volume, timing, and starting aids in order to start the engine. Refer to Cold Starting Aid (Section 16) for more information. Also, refer to the Operation and Maintenance Manual and the Troubleshooting Guide for the engine for more information.

2.1.6 Cold Mode Operation

Cold mode operation is activated based on the coolant temperature. The engine power is limited and the low idle speed may be elevated when in cold mode. Refer to the Operation and Maintenance Manual and the Troubleshooting Guide for the engine for more information.

2.1.7 Engine Protection and Monitoring

The engine control system uses the engine sensors to monitor engine operating conditions. Operation outside of customer or factory configured normal operating conditions will cause the engine to employ warning, derate, or shutdown strategies as defined in the engine protection and monitoring strategy. If any of these conditions occurs, an event is logged in the engine ECU. Refer to Engine Monitoring and Protection (section 15) for more information.

2.2 Factory Configuration Parameters

Factory configuration parameters are ECU software settings that affect the emissions, power, and identification of the engine. These parameters are programmed at the factory during engine assembly and test. Emissions control agencies require that the factory setting for these parameters is stamped on the engine information plate and any changes to these settings require that the engine plate be updated along with the change to the ECU setting. The factory configuration parameters must be reprogrammed if the ECU is replaced and/or the engine rating is changed. These parameters do not need to be reprogrammed if the ECU is re-flashed with a latest version of software flash file. Refer to the Factory Configured Parameters section of this document for more information on definition and configuration of each factory-set parameter.

Factory configuration parameters supported:

- Engine Serial Number
- Rating Number
- Full Load Setting (FLS)
- Full Torque Setting (FTS)

Notes on Programming Parameters

1. Changing parameters protected by factory passwords may void Caterpillar warranty. Consult Dealer Support Network contacts before changing these settings.
2. In order for the programmed values to change, the key switch (switched power only) must be cycled off and on.
3. If there is an interlock error (personality module mismatch), then the programmed parameters will not change. It may appear that the parameters are changed, but they will not change until the "personality module mismatch" code is cleared.

2.3 Engine Component Overview

C7 - C32 Industrial (Equipped w/ADEM A4 ECU)			
Factory Wiring	C7/C9	C11 - C18	C27/C32
Fuel injector: HEUI injector	x		
Fuel injector: MEUI injector		x	x
High efficiency pump	x		
Speed/timing sensor (cam)	2x	x	x
Speed/timing sensor (crank)		x	x
Compression brake solenoids (optional)		x (C15, C18)	
Fuel temperature sensor		x	x
Injection actuation pressure sensor	x		
Atmospheric pressure sensor	x	x	x
Boost (intake manifold air) pressure sensor	x	x	x
Intake air temperature sensor	x	x	x
Coolant temperature sensor	x	x	x
Fuel pressure sensor	x	x	x
Oil pressure sensor	x	x	x
Intake air heater	x		

2.3.1 Engine Control Unit (ECU)

The ECU is located on the left rear side of the engine. The ECU has two connectors, one for the Caterpillar engine harness and the other for the customer harness.

2.3.1.1 Engine Connector (120-pin connector, J2/P2)

Engine system and control information is transmitted between the 120-pin connector on the engine ECU and the engine components through the engine harness. The engine harness provides the interface to the following engine components:

- Engine Sensors
- Fuel Injection System

2.3.1.2 Customer Connector (70-pin connector, J1/P1)

Customer control and display information is transmitted between the 70-pin connector on the engine ECU and the customer-installed components through the customer harness. The customer harness provides the interface to the following components:

- Battery
- Data Links
- Customer Components

2.3.2 Software Flash File

If the ECU is correlated to a computer, then the personality module (also known as “flash file”) is the software for the computer. The term flash file is derived by the method in which the software is programmed into the ECU — a technology known as flash programming. The flash file contains the operating maps that define the performance and operating characteristics of the engine as well as the Industrial application feature support. Once flashed, the ECU contains the following information to identify the flash file and supported ratings:

- Personality Module PN
- Software Gp Release Date
- Rated Power
- Rated Peak Torque
- Top Engine Speed Range
- Test Spec

The information above can be viewed in the Configuration Parameter screen within the Cat® ET service tool.

2.3.3 Fuel Injector

2.3.3.1 HEUI™ Injector (C7 and C9)

The Hydraulically actuated Electronically controlled Unit Injector fuel system is actuated hydraulically by high pressure engine oil. The HEUI injector contains a solenoid to electrically control the quantity, pressure, and timing of the fuel that is injected. Both positive and negative wires to each solenoid are wired directly back to the ECU. Higher voltages (approximately 70 V) and sharp pulses of relatively high current are used to control the injectors. Injector cables are twisted pairs to minimize emissions of electromagnetic noise. There is no OEM connection to the injectors; however, the OEM should ensure that any systems that are sensitive to electromagnetic radiation are not in proximity to the harness that leads to the injectors.

2.3.3.2 MEUI Injector (C11-C32)

The Mechanical Electronic Unit Injector (MEUI) fuel system is actuated mechanically by the injector lobe on the camshaft. The electronic control and mechanical actuation provide a level of control of the timing and fuel volume. The timing advance is achieved by precise control of the unit injector timing. Both positive and negative wires to each solenoid are wired directly back to the ECU. Higher voltages (approximately 108 V) and sharp pulses of relatively high current are used to control the injectors. There is no OEM connection to the injectors; however, the OEM should ensure that any systems that are sensitive to electromagnetic radiation are not in proximity to the harness that leads to the injectors.

2.3.4 High Efficiency Pump (C7 and C9, HEUI Only)

The unit injector hydraulic pump is a variable delivery piston pump. The unit injector hydraulic pump supplies a portion of the engine lubrication oil to the HEUI injectors. The high efficiency of the pump combined with the resistance to flow at the unit injectors pressurizes the oil delivered by the pump.

2.3.5 Injection Actuation Pressure Sensor (C7 and C9, HEUI Only)

The IAP sensor is installed in the high pressure oil manifold. The high pressure oil manifold supplies actuation oil in order to power the unit injectors. The IAP sensor monitors injection actuation pressure.

2.3.6 Intake Air Heater (C7 and C9, HEUI Only)

The engines are equipped with an electric heater that is located behind the air inlet elbow. The electric heater has two functions:

- Aid in starting
- Aid in white smoke cleanup during start-up

The intake air heater works in conjunction with the wait-to-start lamp.

2.3.7 Fuel Pressure Sensor (C7-C18 Only)

Prior to exiting the fuel filter base, the fuel pressure is sampled by the fuel pressure sensor. The signals that are generated by the sensor are used by the engine control in order to monitor the condition of the engine's injectors. This information is used to adjust the fuel delivery of the engine in order to optimize efficiency and to protect the injectors.

2.3.8 Dual Speed Timing Sensors

The engine speed/timing sensors are used to determine both engine speed and fuel injection timing. The C7 and C9 sensors are both triggered by a target wheel on the camshaft. On the C11 through C32, the camshaft position sensor detects information from a target wheel on the camshaft and the crankshaft position sensor detects this information from a target wheel on the crankshaft. Under normal operating conditions the engine monitors one of the position sensors while cranking (camshaft) and one of the position sensors (crankshaft) while running. The design provides for optimized start capability as well as redundancy. Should a failure occur in either of the sensor circuits, the engine can be started and will run with only one sensor.

2.3.9 Compression Brake Solenoids (Option on C15 and C18 Only)

Compression brake is an optional feature offered on select C15 and C18 ratings only. There is one compression brake actuator assembly per pair of adjacent cylinders and one control solenoid per brake assembly. The ECU directly drives the solenoid through the engine harness. Contact the Caterpillar Application Support Center for ratings that are approved to use a compression brake. Refer to Exhaust and Compression Brakes (section 10) for more information.

2.3.10 Fuel Temperature Sensor (C11-C32)

Fuel temperature is measured at the fuel filter base. Fuel is sampled prior to fuel exiting the fuel filter base. Fuel temperature is monitored to adjust fuel rate calculations as part of a fuel temperature power compensation strategy to maintain constant power when fuel temperature exceeds 30° C. Refer to the Fuel Temperature (C11-C18 Only) (section 15.1.6) in the Engine Monitoring and Protection section for more information on fuel temperature compensation.

2.3.11 Atmospheric Pressure Sensor

The atmospheric pressure sensor is an absolute pressure sensor measuring crankcase pressure. Both the boost pressure and oil pressure communicated to service tools and over the data link are calculated by subtracting the atmospheric pressure sensor reading. The atmospheric pressure sensor can measure pressures from 0 kPa (0 psi) to 116 kPa (16.8 psi). The engine implements altitude compensation (derate) strategies based partially on input from this sensor.

2.3.12 Intake Manifold Pressure (Boost) Sensor

The boost pressure sensor is an absolute pressure sensor measuring intake manifold air pressure. Boost pressure as displayed by service tools and communicated over the data link is the value obtained by subtracting the atmospheric pressure (as measured by the atmospheric pressure sensor) from the absolute value measured by the boost pressure sensor.

2.3.13 Intake Manifold Air Temperature Sensor

Intake manifold air temperature is used to determine temperature of the air intake to the engine. This sensor output is used in controlling the inlet air heater and for engine monitoring.

2.3.14 Coolant Temperature Sensor

Coolant temperature sensor is used to determine temperature of the coolant leaving the engine. This sensor output is used in cold start strategies and for engine monitoring.

2.5 Engine System Diagrams

2.5.1 C7/C9 Factory Installed Wiring and Components

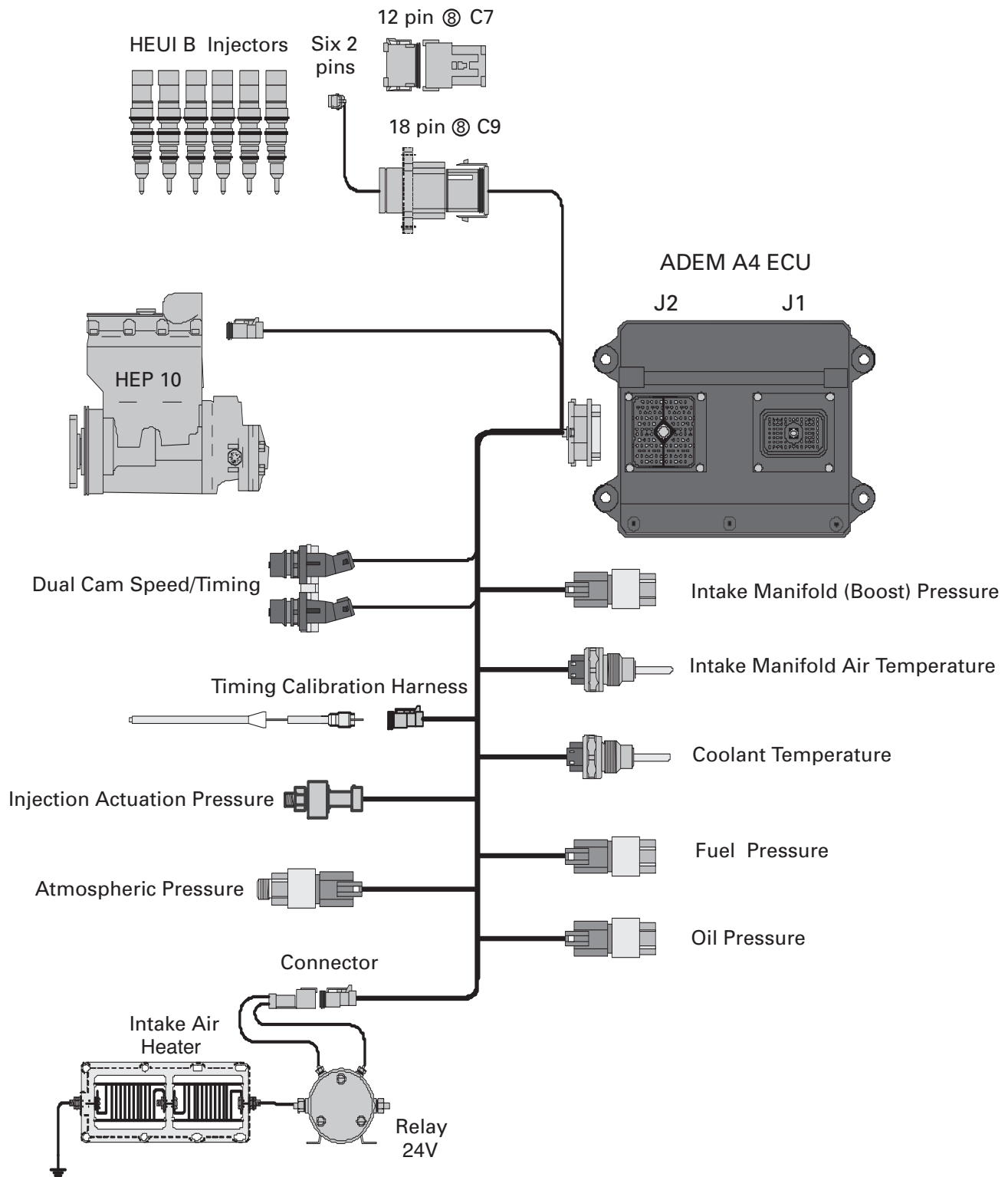

Electrical Schematic, RENR7933, C7 Industrial Engines
 Electrical Schematic, RENR7948, C9 Industrial Engines

2.5.2 C11-C18 Factory Installed Wiring and Components

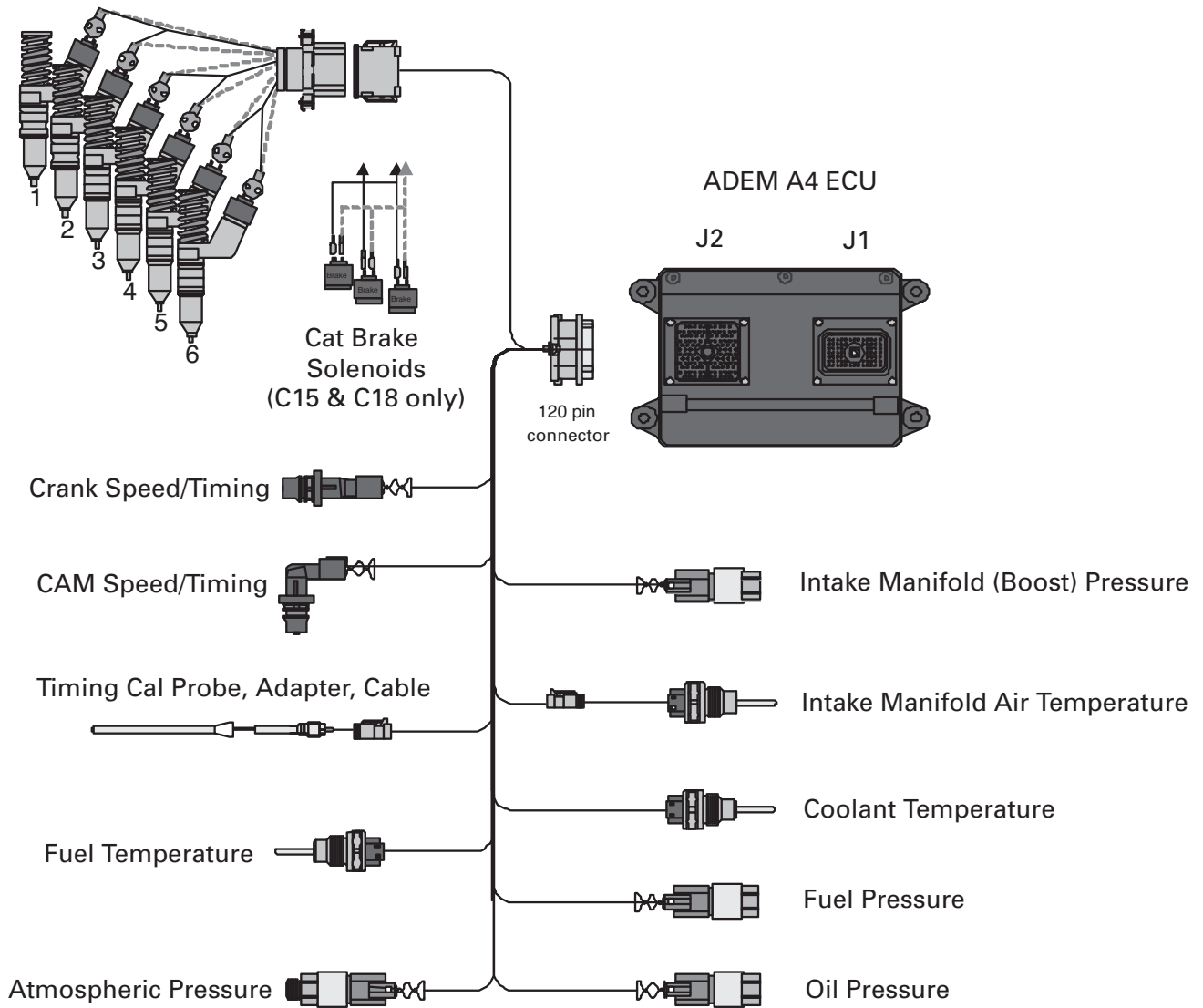

Electrical Schematic, RENR8045, C11/C13 Industrial Engines
 Electrical Schematic, RENR8046, C15/C18 Industrial Engines

2.5.3 C27/C32 Factory Installed Wiring and Components

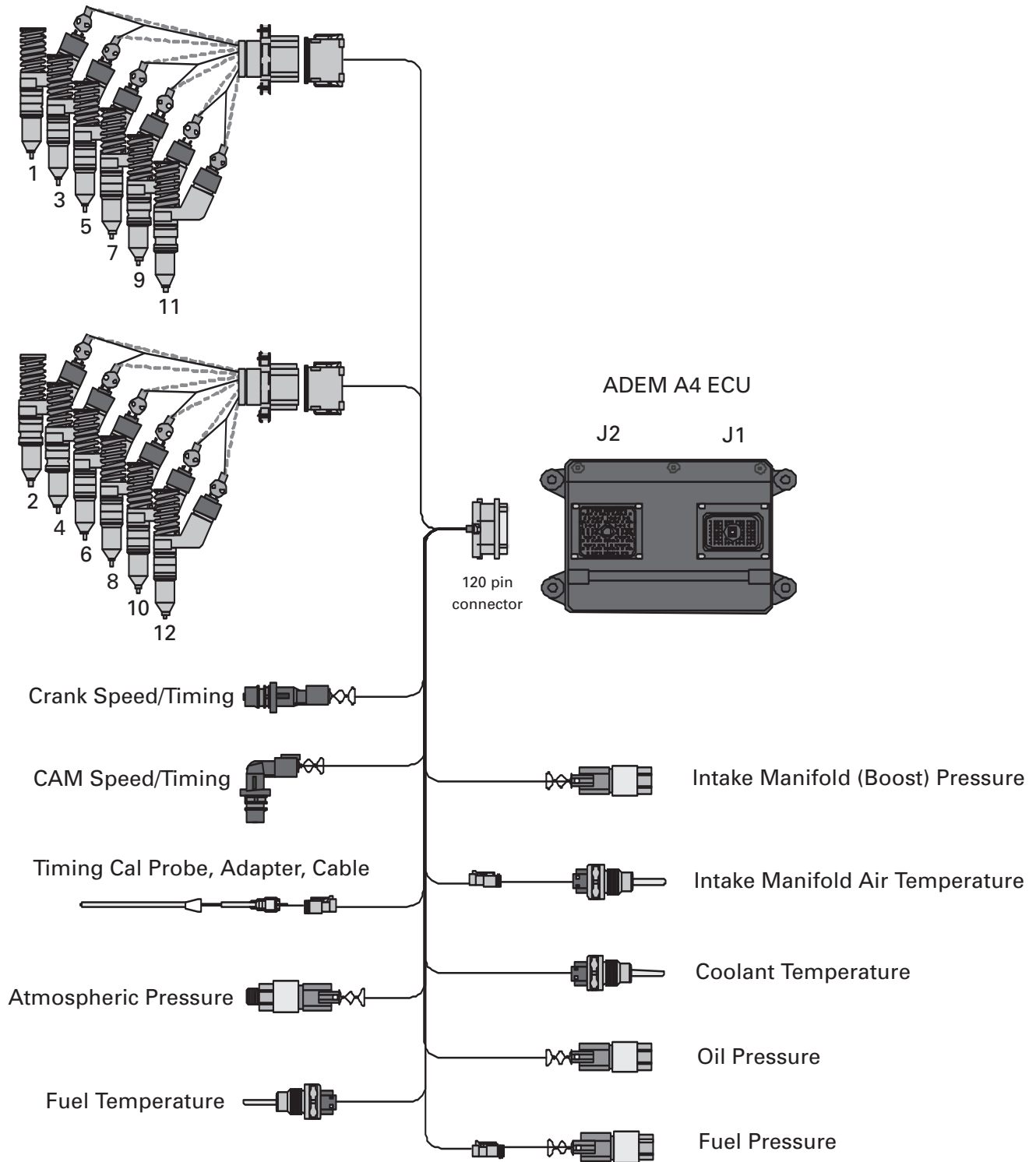

Electrical Schematic, KENR5072, C27/C32 Industrial Engines

3 Customer System Overview

3.1 Customer Configuration Parameters

Customer configuration parameters are ECU software settings that the customer can change in order to suit the needs of the specific application. These parameters are changed within the configuration screen in Caterpillar Electronic Technician (Cat ET). If a customer has more than one engine that should have the same configuration, the Fleet Configuration option is available in Cat ET to save the configuration settings to a file and download the settings to all subsequent engines that are to have the same configuration settings.

Default values for these parameters are set in the factory when the new ECU is flash programmed for the first time. The customer configuration parameters must be reprogrammed if the ECU is replaced and/or the engine rating is changed. These parameters do not need to be reprogrammed if the ECU is re-flashed with a latest version of software flash file.

Refer to the Appendix sections for customer configuration parameters and monitoring system parameters for a complete list of supported programmable parameters. Further definition of each parameter can be found within the section of the document that defines a software feature that uses the parameter to support installation or operation of that specific software feature.

Customer configuration parameters in legacy product that are no longer supported:

- Direct Fuel Control Mode
- Engine Oil Weight (C-9 Engine)
- Engine Power Trim

Notes on Programming Parameters

1. Changing parameters protected by factory passwords may void Caterpillar warranty. Consult Industrial Application Support Center contacts before changing.
2. In order for the programmed values to change, the key switch (switched power only) must be cycled off and on.
3. If there is an interlock error (personality module mismatch), then the programmed parameters will not change. It may appear that the parameters are changed, but they will not change until the “personality module mismatch” code is cleared.

3.2 Customer Component Overview

Industrial engines offer a set of application features that can be specified by the customer to meet the application operating requirements. Application of these features requires a different set of customer installed components based on the features selected. Each installation requires the minimum set of customer installed components listed in Table 1. Customer installed components for application specific features are listed in Table 2. See the section identified with each component for more information on component usage and requirements.

Table 1: Required Customer Installed Components

Required Components	Section
Battery	Power and Grounding Considerations
Battery Disconnect Switch	Power and Grounding Considerations
Key Switch	Power and Grounding Considerations
Warning Lamp	Engine Monitoring and Protection
Diagnostic Lamp	Engine Monitoring and Protection
Wait-to-Start Lamp (C7 & C9)	Starting and Stopping the Engine
Speed Demand Input ⁽¹⁾	Engine Speed Demand
Engine Service Tool Connector	Connectors and Wiring Harness Requirements
Inlet Air Heater Battery Connection (C7 & C9)	Cold Starting Aid

⁽¹⁾ Speed Demand input method selected may require components from the optional component list (i.e. throttle position sensor, PTO, etc.)

Table 2: Optional Customer Installed Components

Optional Components	Section
Remote Shutdown Switch	Starting and Stopping the Engine
Air Shutoff Relay	Starting and Stopping the Engine
Throttle Position Sensor	Engine Speed Demand
PTO Set/Resume/Interrupt Switches	Engine Speed Demand
PTO Ramp Up/Down Switches	Engine Speed Demand
Intermediate Engine Speed Switch	Engine Speed Demand
Torque Limit Switch	Engine Speed Demand
Overspeed Verify Switch	Engine Monitoring and Protection
Maintenance Clear Switch	Engine Monitoring and Protection
Maintenance Overdue Lamp	Engine Monitoring and Protection
Coolant Level Sensor	Customer Installed Components
Auxiliary Pressure Sensor	Customer Installed Components
Auxiliary Temperature Sensor	Customer Installed Components
Ether Solenoid	Cold Starting Aid
Exhaust Brake Relay	Exhaust and Compression Brakes
Exhaust Brake Enable Switch	Exhaust and Compression Brakes
Retarder Lo/Med/Hi Switches	Exhaust and Compression Brakes
Retarder Lamp	Exhaust and Compression Brakes
J1939 Data Link	Data Link Support
J1939 Terminating Resistors	Connectors and Wiring Harness Requirements
Industrial Messenger	Operator Displays

3.2.1 Customer Installed Components Diagram

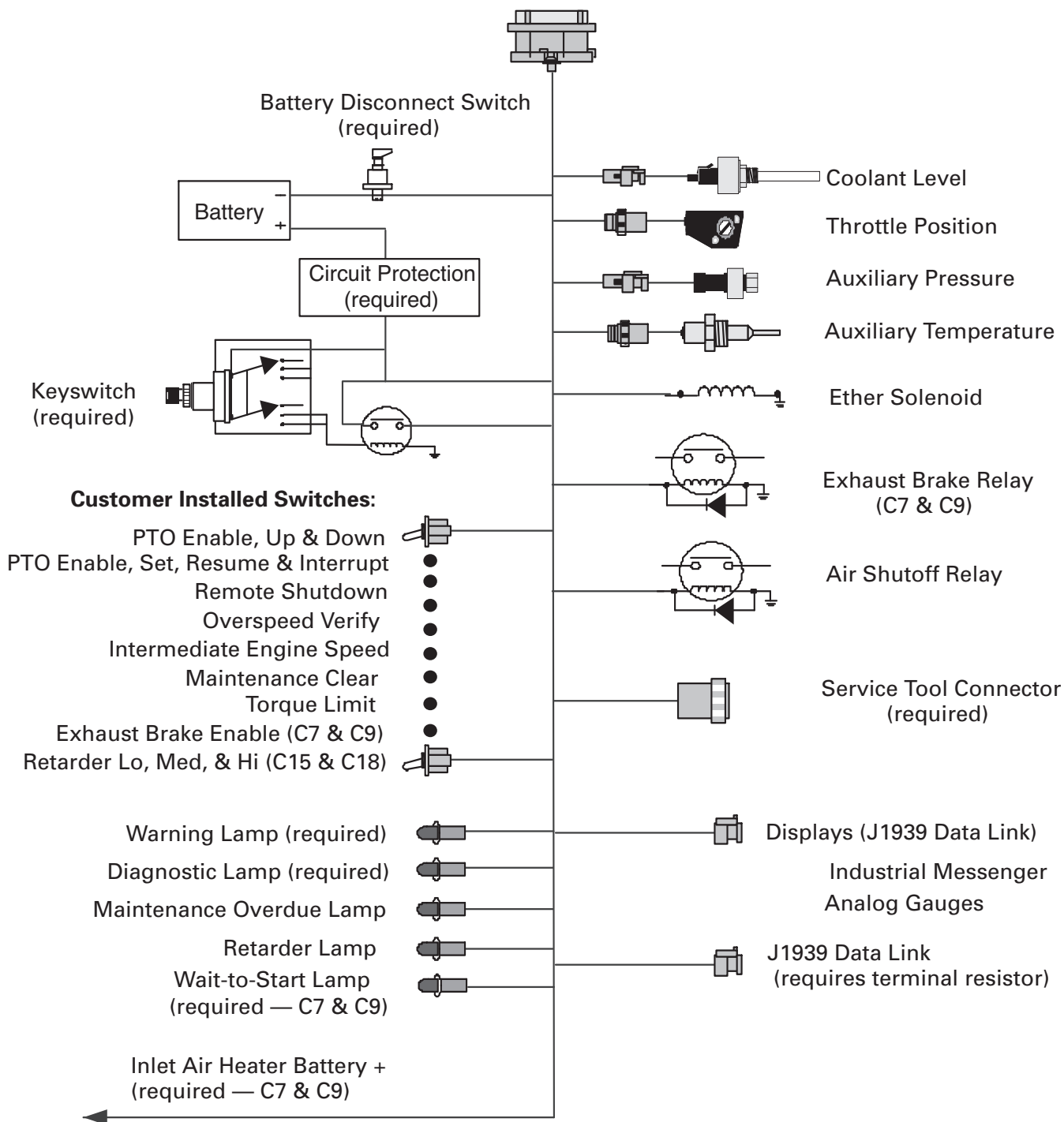

4 Power and Grounding Considerations

4.1 Power Requirements

4.1.1 System Voltage

The electronic control system can operate with either a 12 VDC or 24 VDC electrical system. The switched positive battery and the un-switched positive battery connections to the ECU are made at the P1/J1 customer harness connector.

The minimum battery voltage for the ECU to actuate the fuel injectors, regardless of system voltage (12 VDC or 24 VDC) is 9 VDC. The ECU monitors system voltage input (un-switched power) and triggers a diagnostic code if the voltage drops below 9 VDC and then returns above 9 VDC.

The batteries, charging system, starter, and associated wiring must be sized and designed correctly to allow the starter to crank the engine to an appropriate minimum engine speed to start the engine. The engine installation should meet the minimum cranking speeds at the COLDEST ANTICIPATED TEMPERATURES. For C7 and C9 the typical minimum cranking speed required to start the engine is 150 rpm. For all other engines, the typical minimum cranking speed required to start the engine is 100 rpm. Also reference TMI System Data for Minimum Cranking Speed Data.

4.1.2 Battery (+) Connection

The ECU requires four un-switched battery (+) inputs and an ignition key switch input. When the key switch is in the off position, the ECU is in sleep mode where it draws a very small residual current through the four un-switched battery inputs. When the key switch input is turned on, the ECU will become active, allowing the engine to start and run.

The ignition key switch input (switched power) is made through pin P1/J1-70 and carries approximately 1.2 mA (for a 12 VDC system).

These four un-switched battery (+) input connections are made through pins P1/J1 - 48, 52, 53, and 55. These four inputs should run directly from the P1/J1 connector to the positive side of the battery. These four inputs carry nearly all power to the ECU during peak requirements. These inputs provide the ECU power when the vehicle key switch is in the off position. Refer to Table 3 for more information on ECU current requirements. All four of these un-switched battery (+) inputs must be provided to prolong the service life of the ECU.

Table 3: ECU Current Requirements

Parameter	ADEM III*	ADEM A4**
12V		
Sleep Mode Current (key switch off)	6.7 mA	6.5 mA
Power On with no I/O (key switch on — not running)	550 mA	1500 mA
Inrush Amplitude	35 A	50 A
Inrush Duration	8 ms	4 ms
Normal Operating Current — Peak	20 A	22 A
Normal Operating Current — RMS	7.1 A	7.7 A
24V		
Sleep Mode Current (key switch off)	7.5 mA	12
Power On with No I/O (key switch on — not running)	450 mA	850
Inrush Amplitude	50 A	96 A
Inrush Duration	5.5 ms	3 ms
Normal Operating Current — Peak	16 A	17 A
Normal Operating Current — RMS	2.2 A	4.0 A

*Engines with ADEM III ECU

- BEJ 3126B
- DCS 3126B
- CLJ C-9
- BCX C-10
- BDL C-12
- BEM C-15
- BFM C-16

** Engines covered by this publication have an ADEM A4 ECU

4.1.3 Circuit Protection

Each of these four un-switched battery (+) inputs requires a 10 Amp circuit breaker rated for a continuous duty load of 7 Amp at 12 or 24 VDC. Powering the ECU through dedicated circuits with circuit breakers reduces the possibility of degradation of electronic control system performance. This also minimizes the chance of an engine shutdown due to a short in the electrical system. Additional loads should not be connected between the ECU and the circuit protection for the ECU. Circuit protection wiring is illustrated in Figure 1. Caterpillar prefers the circuit protection to be located in the machine cab (if applicable). If not in the cab, for ease of service, the circuit protection should be located in an easily accessible and documented location.

NOTE: *DO NOT use in-line fuses for circuit protection. Caterpillar recommends the use of circuit breakers for circuit protection. Circuit breakers should be located with other circuit protection in a centrally located, dedicated panel. If circuit breakers that automatically reset are used, consideration of the environment of the location of the breaker is critical and the effect on the trip point is critical. The trip point of some circuit breakers can be significantly reduced below the rated trip point if the circuit breaker is exposed to high temperatures. This can cause intermittent shutdowns that result in the needless replacement of electronic components.*

Figure 1: Battery (+) Wiring and Circuit Protection Diagram

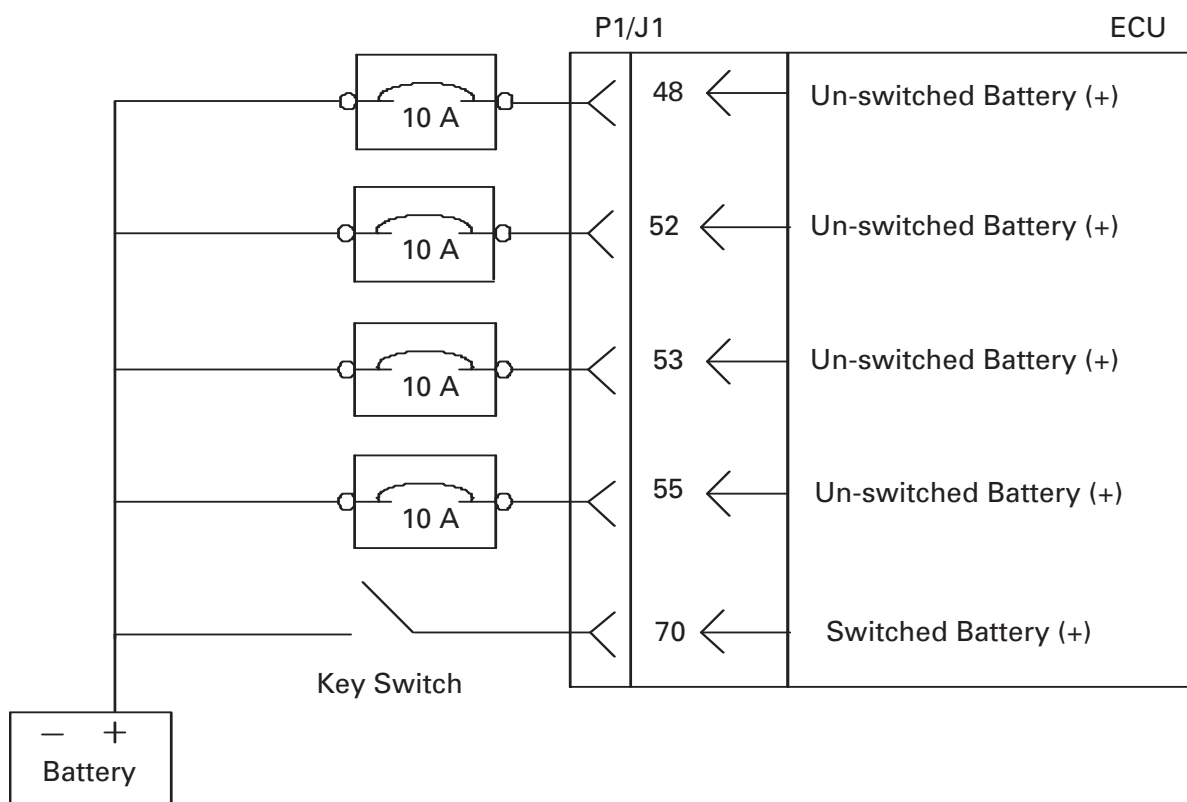

NOTE: *For already installed Tier 3 and earlier applications, four un-switched positive battery connections and four ground connections are recommended but not required. New installations, especially those with HEUI fuel systems, should be designed with all four un-switched positive battery connections.*

NOTE: *For already installed Tier 3 and earlier applications, a single 25 Amp circuit breaker was used. New installations, especially those with HEUI fuel systems, should be designed with four individual 10 Amp circuit breakers.*

4.1.4 ECU Internal Battery

The ECU has an internal battery that powers critical circuits and battery backed memory when all power sources are disconnected from the ECU. The internal battery is expected to meet a 15-year battery life if the ECU is stored, or switched off without any external battery connection, at a storage temperature at or below 30° C. The exact storage life is dependent on temperature. The storage life may fall to as low as 10 years if the storage temperature is elevated to 70° C.

4.2 Engine Grounding

Proper grounding for vehicle and engine electrical systems is necessary for proper performance and reliability. Improper grounding results in unreliable electrical circuit paths. Stray electrical currents can damage main bearings, crankshaft journal surfaces, and aluminum components. They can also cause electrical noise, degrading control system, vehicle, speedometer, and radio performance. These problems are often very difficult to diagnose and repair.

All ground paths must be capable of carrying any conceivable fault currents.

4.2.1 Correct Power Supply Wiring

- ECU battery (+) wires connect directly to battery, not via starter motor
- ECU battery (-) wires connect directly to battery, not via chassis or engine ground
- Power supply wires go to all four positive pins and all four negative pins on the ECU connector
- Engine is grounded and connected directly to battery

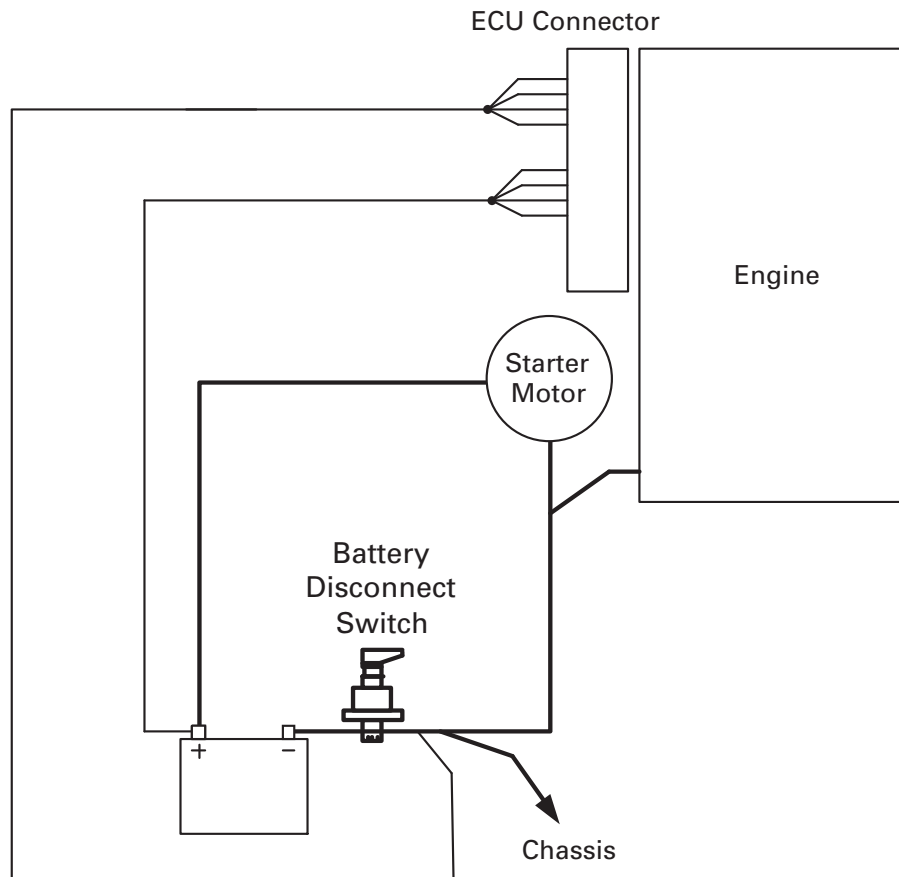

NOTE: Circuit breakers are not shown in the figure above.

4.2.2 ECU Battery (-) Connections

The ECU requires four battery (-) connections to battery (-). These four ECU battery (-) input connections are made through pins J1- 61, 63, 65, and 69. All four of these pins should be connected directly to the negative terminal on the battery, not to the engine ground stud or any other ground location. These connections should be #14 AWG GXL wire.

NOTE: *For already installed Tier 3 and earlier applications, four un-switched positive battery connections and four ground connections are recommended but not required. New installations, especially those with HEUI fuel systems, should be designed with all four un-switched positive battery connections.*

4.2.3 Engine Ground Stud to Vehicle Battery Ground

To ensure proper functioning of the vehicle and engine electrical systems, there must be a direct wire path from the engine ground stud to the battery negative post.

A maximum of three ring terminals are to be connected to the engine ground stud to ensure ground connection integrity. More than three terminals can cause the stud to loosen too easily. Caterpillar recommends splicing like-size wires together as a method of reducing ring terminal congestion at the ground stud.

A connection routed to a main frame ground can also be made if the following guidelines are followed:

1. Connections to the frame must not be made with star washers. Star washers should not be counted on to remove paint from painted surfaces. Use flat washers for this connection, with the paint completely removed in this area.
2. Any paint must be completely removed from the frame rail at the point where the connection is made. Failure to do so reduces the effectiveness of the connection.
3. The ground path is not made through frame cross members. Bolted connections of frame cross members may not always provide required continuity for this critical connection.
4. Conductive grease or other methods used to reduce/eliminate the effect of corrosion on the frame rail connection.

Caterpillar does not recommend a connection from the engine ground stud to the main frame rail at a connection point different than where the battery ground connection is made. A two-point frame rail connection method depends on frame rail connections. Manufacturing process control of frame rail connections is difficult to control. This multiple frame rail connection scheme is also more difficult to troubleshoot.

NOTE: *Refer to Industrial Engine General Dimension Drawings for ground stud location and detail.*

4.3 Air Starter Equipped Vehicles

Refer to the guidelines for connection to the main frame ground in Engine Ground Stud to Vehicle Battery Ground (section 4.2.3).

4.4 Sensor Common Connections

Certain components that interface directly with the ECU are connected to the dedicated sensor returns at the P1/J1 customer connector. Separate sensor returns are provided for analog and digital signals.

4.4.1 Digital Sensor Return

P1/J1 Pin 5 should only be connected to the ground side of the coolant level sensor.

4.4.2 Analog Sensor Return

P1/J1 Pin 3 should only be connected to the ground side of the auxiliary pressure and auxiliary temperature sensors.

NOTE: Do not connect the Throttle Position Sensor (TPS) ground to either the analog or digital sensor return.

4.5 Suppression of Voltage Transients

NOTE: The installation of transient suppression at the source of the transient is required. Caterpillar follows a stringent electrical environment standard that is similar to SAE recommended practices.

The use of inductive devices such as relays and solenoids can result in the generation of voltage transients in electrical circuits. Voltage transients that are not suppressed can exceed SAE specifications and lead to the degradation of the performance of the electronic control system.

Figure 2: Voltage Suppression Diagram

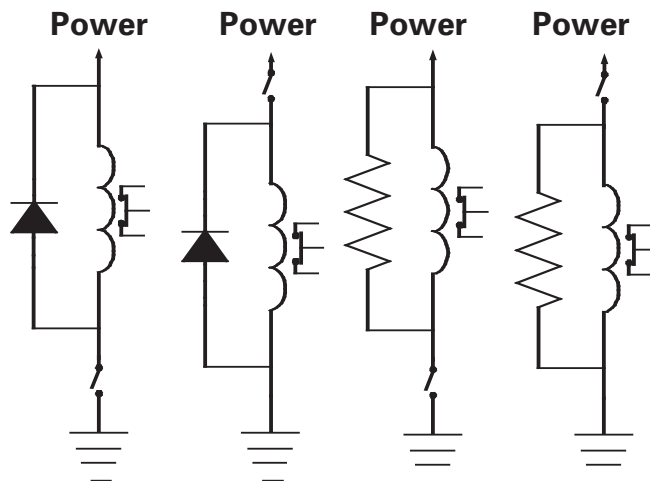

The customer should specify relays and solenoids with built-in voltage transient suppression. Refer to Figure 2 for ways to minimize voltage transients from relays and solenoids without built-in voltage transient suppression. Techniques include the installation of a diode or resistor of the proper size in parallel with the solenoid or the relay coil. Other techniques may also be used.

Inductive devices such as relays or solenoids should be located as far as possible from the components of the electronic control system. Wiring harnesses that are installed by the customer should be routed as far as possible from the wiring harness of the electronic control system in order to avoid problems that are associated with electrical noise.

4.6 Battery Disconnect Switch

The machine OEM should incorporate a battery disconnect switch on the negative battery side of the battery circuit. The purpose of this switch is to disconnect the battery during long-term storage and to prevent electrical shock during machine service. This switch should not be used as an emergency shutdown switch or as an E-stop. Refer to Power Requirements (section 4.1) for information on ECU battery life.

NOTE: *The battery disconnect switch is not an emergency shutdown switch.*

NOTE: *This is a change from previous generations of industrial engines. Previously, Caterpillar recommended that the battery isolation switch be on the battery +.*

5 Connectors and Wiring Harness Requirements

Industrial engines have several attachment options in the price list that provide different options for the customer to interface to the engine ECU. The options are summarized as follows:

- ECU Only (standard option)
- Customer Harness
- Factory Installed Panel

The ECU Only option is included in the base engine pricing arrangement. Customer harness and factory installed panels are price listed options. The ECU Only option provides complete access to all ECU connections and has the customer providing all wiring to the engine. The Customer Harness and Factory Installed Panels provide the 70-pin connection to the ECU, a service tool connector on engine, and a customer interface connection. The customer interface connection can vary depending on which attachment option is selected. Typically the customer connector interface is a Deutsch DRC 40-pin connector.

This section covers component and wiring harness design requirements for the customer to design the required harnessing to interface to the engine. The pinout information for the ECU and customer harness connectors are not included in this section. The pinout information can be found within the section that defines a components installation and also in pinout summary tables in the Appendix.

5.1 Wiring Harness Components

5.1.1 Deutsch DT Connector

The DT connector is the low-cost preferred choice for inline applications. The connector is available in 2, 3, 4, 6, 8, and 12 terminal configurations. It is also intended for SAE J1939 application use. The wire size range the connector will accept is 0.8 mm² (18 AWG), 1.0 mm² (16 AWG), and 2.0 mm² (14 AWG). The plug assembly with interface seal accepts socket terminals and the receptacle assembly accepts pin terminals. Sealing plugs are to be used in unused wire cavities.

The DT connector has a wedge that locks the pins and the sockets in place. The wedge can be removed and replaced without cutting the wires. The wedge removal tool (p/n 147-6456) can be used to aid in the removal of the wedges. When the receptacle is inserted into the plug, a click should be heard as the two halves lock together. The connector should not be able to be pulled apart.

Connectors and Wiring Harness Requirements

The following tables contain the Caterpillar part numbers for DT inline connector plug and receptacle kits for all available number of pin positions. The kit is comprised of the plug or receptacle and the respective locking wedge.

STANDARD DT CONNECTORS		
Positions	Cat Part Number	
	Plug Kit	Receptacle Kit
2	155-2270	102-8802
3	155-2260	102-8803
4	155-2271	197-7565
6	155-2274	102-8805
8	155-2265	102-8806
12	155-2255	102-8801

J1939 DT Connectors (All 3 Position)	
Component	Cat Part Number
Plug Kit	174-0503
Receptacle Kit	176-9299
Plug Resistor	174-3016
Receptacle Resistor	134-2540
Receptacle Tee	133-0970

The connector has also been configured for bulkhead mountings and integral component applications (e.g. lamp housing, engine sensor, etc.). Terminal configurations and mounting configurations vary for these applications. Contact the local Deutsch sales contact for more information on these connectors.

5.1.2 Deutsch HD-10 Connectors

This circular connector is used for inline and bulkhead applications. It is more expensive than other connector choices but easier to adapt to wire harness conduit applications (i.e. CSA, Marine, etc.). The connector is available in 3, 6, and 9 terminal configurations. The wire size range the connector will accept is 0.8 mm² (18 AWG), 1.0 mm² (16 AWG), and 2.0 mm² (14 AWG), and 3.0 mm² (12 AWG). The plug assembly with interface seal accepts socket terminals and the receptacle assembly accepts pin terminals. Sealing plugs are to be used in unused wire cavities.

Ensure that the wires in the plug align with the corresponding wires in the receptacle. Ensure that the index markings on the plug and the receptacle are aligned. Rotate the plug until the plug slips into the receptacle. Rotate the coupling by approximately 90 degrees until a click is heard. Ensure that the plug and the receptacle cannot be pulled apart.

The following table contains the Caterpillar part numbers for HD-10 inline connector plug and receptacle for all available number of pin positions. Most common usage for the HD-10 connector is the 9-position connectors used for Cat service tool interface.

HD-10 CONNECTORS		
Positions	Plug Kit	Receptacle Kit
3	8T-8731	8T-8732
6	8C-3654	7T-3272
9	8T-8735	8T-8736

Interface sealing caps and wire strain reliefs are available for the connectors. Contact the local Deutsch sales contact for more information on these components.

5.1.3 Deutsch DRC/AEC Connector

The connector is available in 24, 40, and 70 terminal configurations. It can be used for inline or bulkhead mountings. The connector is frequently used in electronic box applications. The wire size range the connector will accept is 0.8 mm² (18 AWG), 1.0 mm² (16 AWG), and 2.0 mm² (14 AWG). The plug assembly with interface seal accepts socket terminals and the receptacle (header) assembly accepts pin terminals. Sealing plugs are to be used in unused wire cavities.

The optional Caterpillar customer harness uses the DRC 40 terminal configuration. Customer interface with this harness is the 40-position plug connector (Caterpillar part number 8T-9834). This connector is labeled as P61 on engine wiring schematics. The DRC connectors are keyed to align correctly when the two parts are mated together. An allen head screw holds the two connectors in place. Ensure that the allen head screw is tightened to a torque of 2.25 + 0.25 N•m (20 + 2 lb-in.).

5.1.4 ECU 70-Pin Connector

5.1.4.1 ECU 70-Pin Mating Connector (J1)

The ECU uses an integral rectangular 70-terminal AMP connector to interface to the OEM vehicle wiring harness (AMP part number 776241-1, Caterpillar part number 160-7689). ECU connector screw torque should be 6 Nom ±1 Nom (4.4 lb-ft ± 0.7 lb-ft, 53 lb-in. ± 8.9 lb-in.). Reference Figure 1 for connector picture and placement on the ECU.

5.1.4.2 ECU Connector Endbell

An AMP 776498-1 (Caterpillar part number 237-0336) connector endbell is available to provide additional protection and controlled wire routing for the harness at the ECU. This is a new part number for the ADEM A4 control.

Figure 1: ECU Customer Connector (J1)

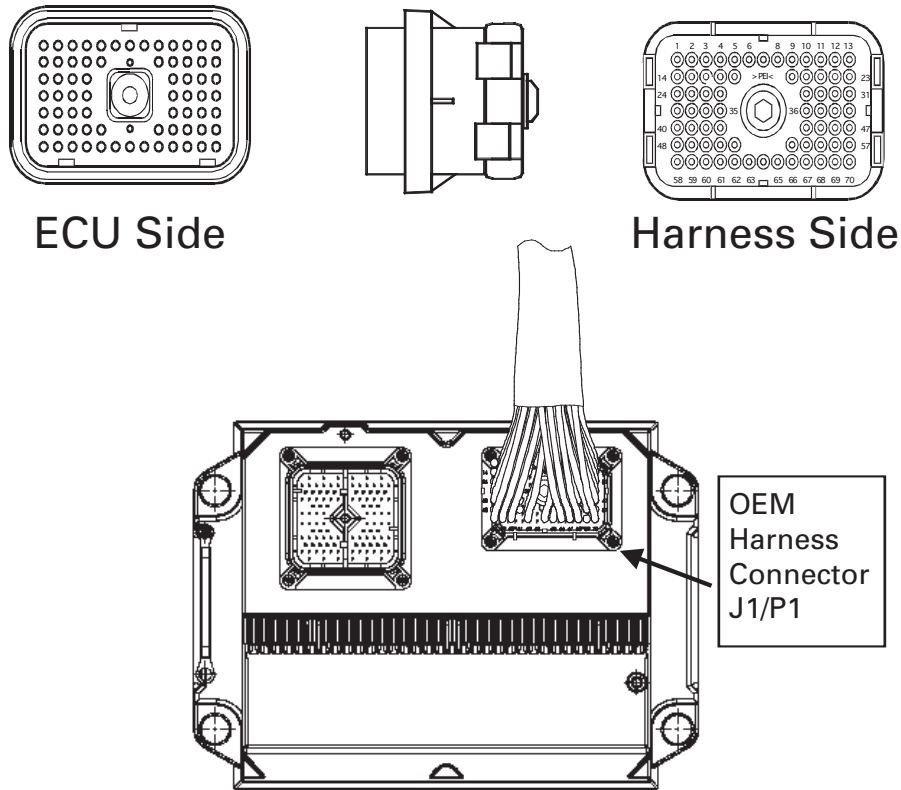

5.1.4.3 ECU Harness Tie-Down Point

The ADEM A4 ECU has a harness mounting bracket (Caterpillar part number 233-0891) mounted to the ECU. The wiring harness exiting the ECU connector (J1) must be secured to the ECU housing mounting bracket using a tie wrap clamp (Caterpillar part number 9X-6772). The wiring harness design is to adhere to design guidelines such that the ECU harness at the J1 connector meets the requirements defined in Wiring Harness Design (section 5.2).

The wire harness for ECU connector J1 must be secured to the engine within 600 mm from the ECU harness bracket, preferably 300 ± 50 mm. The referenced length is measured along the centerline of the harness bundle. The wire harness is not to be pulled tight between the ECU harness bracket and first engine tie-down point such that the mounting interferes with the ECU shock mounting.

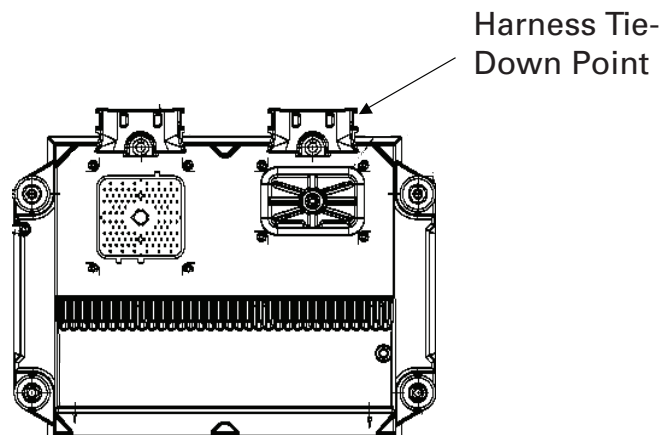

5.1.4.4 ECU 70-Pin Connector Sealing (Weatherproofing)

ECU connector interface seal is serviceable using Caterpillar part number 159-9322.

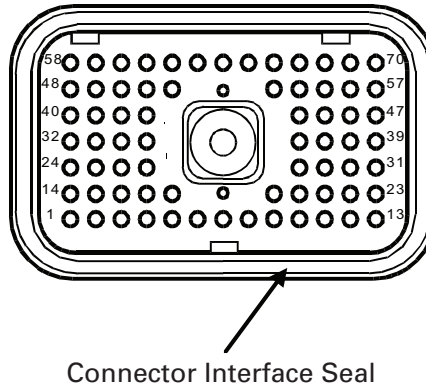

5.1.5 Connector Terminal Contacts

There are two types of terminal contacts available for production use: machined, and stamped and formed. Machined terminal contact, also referred to as a solid contact, is used for low volume harness production and for field repair. Stamped and formed contact is used for high volume harness production and is the lowest cost terminal contact option.

Terminal contacts are available with nickel or gold plating. Gold plating should be used for applications of 5 volts or less and/or less than 100 milliamps. Typically these low level circuits require low resistance at the pin/socket connection and gold plating is the best low-cost choice. Nickel-plated contacts can be used in power-type circuits or circuits where low resistance at the pin/socket connection is not a concern.

Gold-plated contacts can be used in all circuit applications regardless of the voltage and current requirements. Gold plating provides some marginal improvement in vibration versus nickel plating. Caterpillar requires that only gold-plated sockets be used in the ECU connector (J1).

Note: *Deutsch nickel-plated stamped and formed terminals are not recommended for use because of excessive voltage drop experience in laboratory tests.*

Connectors and Wiring Harness Requirements

Wire Usage (AWG-type)	Contact	Type	Plating	Cat P/N
ECU Connector (J1)				
#16/ #18 - SXL and #14/#16/#18 - GXL	Socket	Stamped & Formed	Gold	126-1766
#14 - All	Socket	Machined	Gold	126-1768
#16/#18	Socket	Machined	Gold	9X-3402
HD-10/DT Connector (Standard)				
#14	Socket	Machined	Nickel	9W-0844
#14	Pin	Machined	Nickel	9W-0852
#16/#18	Socket	Machined	Nickel	186-3736
#16#18	Pin	Machined	Nickel	186-3735
#14	Socket	Machined	Gold	126-1768
#14	Pin	Machined	Gold	126-1767
#16/#18	Socket	Machined	Gold	9X-3402
#16/#18	Pin	Machined	Gold	9X-3401
DT Connector (J1939 only)				
#16/#18 (J1939)	Socket (extended)	Machined	Gold	133-0969
#16/#18 (J1939)	Pin (extended)	Machined	Gold	133-0967

5.1.6 Wire Type and Gauge Size

5.1.6.1 Wire Selection

Wire must be of a type suitable for the application. Wire must be selected so that the rated maximum conductor temperature is not exceeded for any combination of electrical loading, ambient temperature, and heating effects of bundles, protective braid, conduit, and other enclosures. Typical factors to be considered in the selection are voltage, current, ambient temperature, mechanical strength, connector sealing range, abrasion, flexure, and extreme environments such as areas or locations susceptible to significant fluid concentrations.

5.1.6.2 Wire Size

The minimum conductor size used on Caterpillar products is 0.8 mm² (18 AWG). Smaller conductors are susceptible to breakage and fatigue failures. SAE J1614, wiring distribution systems for construction, agricultural, and off-road work machines require wire sizes no smaller than 0.8 mm² (18 AWG).

ECU wire size requirements per connection are:

Circuit	Size (AWG)
Battery Negative	14
Positive Battery: Switched	14-18
Positive Battery: Un-switched	14
Digital Sensor Power	16-18
Digital Sensor Return	16-18
Analog Sensor Power	16-18
Cat Data Link ⁽¹⁾	18
J1939 (CAN) Data Link ⁽²⁾	18
Switch to Ground Input	18
Low Side (300 mA) Driver	18
High Side (2 A) Driver	14-16
Active Analog Input	18
Passive Analog Input	16-18
PWM Input	18

⁽¹⁾ 143-5018 Cable (Twisted Pair) ⁽²⁾ 153-2707 Cable (Shielded Twisted Pair)

5.1.6.3 Wire Insulation

NOTE: Thermoplastic Polyvinyl Chloride (PVC) insulation shall not be used in wire harness designs because of its low operating temperature range (-40 to 85° C), and melt and flammability characteristics.

Cross Linked Polyethylene (XLPE) is the primary wire insulation type used in chassis, cab, and engine compartment locations. It has a temperature rating of -50 to 120° C. The voltage rating for Caterpillar 1E0815 wire and SAE J1128, Type SXL is 50 volts. The circuit voltage shall be considered when making wire selections. This wire insulation is also available with 50, 150, 300, or 600-volt ratings.

Outside diameter insulation range is 2.26 to 3.33 mm (0.089 to 0.131 in.). The table below provides insulation diameter range for each gauge and wire type.

ECU CONNECTOR WIRE INSULATION AND GAUGE SIZE		
Wire Type	Wire Gauge	Insulation Diameter
GXL	14	0.114 - 0.125
	16	0.098 - 0.112
	18	0.089 - 0.098
SXL	16	0.116 - 0.131
	18	0.103 - 0.118

METRIC EQUIVALENTS FOR AWG WIRE NUMBERS							
AWG	20	19	18	16	14	12	4
Diameter (mm ²)	0.5	0.65	0.8	1	2	3	19

5.1.6.4 Battery Cable Insulation

The preferred minimum cable size for the starting system is 2/0 AWG wire size with a wire specification that meets SAE J1127 for Low Voltage Battery Cable, type SGX. The start motor to frame ground cable shall be no smaller than the battery cables but may need to be larger for dual starting motor systems. This is to ensure that starting currents will be adequately handled in jump-start conditions.

5.1.7 Connector Seal Plug

All unused cavities for sockets and pins must be filled with seal plugs in order to ensure that the connector is sealed. Two options are available for plugging unused connector cavities. Either the Deutsch 114017 (Caterpillar part number 8T-8737) or PEI Genesis 225-0093-000 (Caterpillar part number 9G-3695) sealing plugs can be used.

Figure 2: Plug Insertion in Unused Connector Cavity

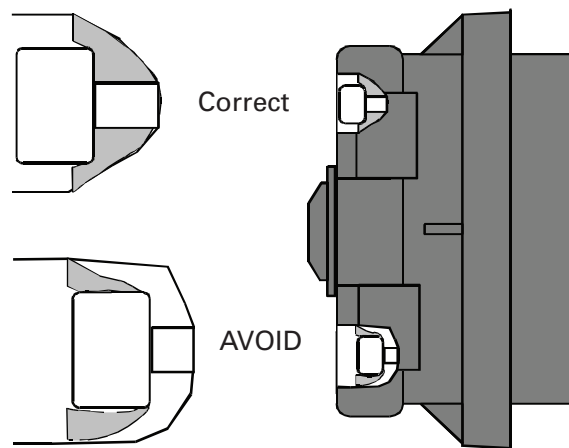

The seal plugs are installed from the wire insertion side of the plug or receptacle. Correct installation of either of these cavity plugs is critical to maintain connector sealing integrity. Figure 2 illustrates the correct insertion of the plug. The seal plug cap is designed to rest against the seal, not inserted in the hole in the seal.

5.2 Wiring Harness Design

5.2.1 Harness Routing

Wiring shall be routed to ensure reliability and to offer protection from the following:

1. Chafing/rubbing/vibrating against other parts.
2. Use as handholds or as support for personal equipment.
3. Damage by personnel moving within the vehicle.
4. Damage by impact, or thrown or falling debris.
5. Damage by battery acid fumes, engine and hydraulic oil, fuel, and coolant.
6. Abrasion or damage when exposed to rocks, ice, mud, etc.
7. Vandalism damage (to the maximum extent practicable).
8. Damage by moving parts.
9. Harsh environment such as nitrite mines, high temperatures, or areas susceptible to significant fluid or fume concentration.

Wire harnesses shall not be located in close proximity to oil and fuel fluid fill areas or below fuel and oil filter locations. If these locations cannot be avoided, additional protective covers and shields must be provided to protect the harness.

Harnesses shall be located a minimum of 50 mm from high heat sources (e.g. exhaust manifolds, turbochargers, hydraulic components, etc.) to avoid insulation and/or connector deterioration.

5.2.2 Maintenance Considerations

The maintainability of the wiring system shall be an important consideration in the selection, design, and installation of harnesses, cable assemblies, and other wiring system components. All wiring components shall be accessible, repairable, and replaceable (i.e. connector terminals).

High-pressure wash systems are now in frequent use by maintenance people. When locating electrical connectors, place them in accessible locations while using other physical elements for protection and prevention of direct exposure to wash systems (e.g. brackets, housings, sheet metal structure, etc.). Where direct exposure to high pressure wash systems cannot be avoided, protective shields will need to be designed and installed.

5.2.3 Appearance

The primary purpose for the wiring system is to provide electrical and electronic component function. There is, however, another important and intangible value to consider when designing the wiring system. The appearance of the wire harness and its routing path should reflect an orderly, well-thought-out design plan. A poorly executed plan can have a negative impact on customer perceptions of the entire product. Use the product's horizontal and vertical lines for routing paths. Design preformed bends into large harnesses to facilitate product assembly and improve appearance. Use other product elements to shield or hide the harness from view. Benchmark new automotive product applications for ideas.

5.2.4 Harness Bends

Routing of the harness should insure connector seals are not stressed because the harness curvature is too close to the connector. This applies to routing of customer lines on or near the engine harness as well as the ECU customer connector (J1/P1).

The minimum bend radius for a braided wire harness as measured from the inside of the bend shall be four times the outer diameter of the harness. Tighter bends are possible if the bend is preformed during harness manufacture. The bend radius size and location must be specified on the wire harness drawing.

Bends in jacketed cables shall be based on manufacturer recommendations. A bend must not adversely affect the operating characteristics of the cable. For flexible coaxial cables, the bend radius must not be less than six times the outside diameter. For semi-rigid coaxial cable, the bend radius must not be less than ten times the outside diameter of the cable.

The minimum bend radius for flexible conduit must be six times the outer diameter of the conduit. Conduit bends shall not cause internal chafing of the wiring.

5.2.5 Harness Bends Near Connectors

Avoid wire harness bends within 25 mm (10 in.) of the connector. When a harness bend is too close to the connector, the connector seal is stretched away from the wire, providing an opening for moisture entry. The wire should exit perpendicular to the connector before curving as necessary for routing. Refer to illustration in Figure 3.

Figure 3: Example of Wire Harness Routing at the ECU Connector

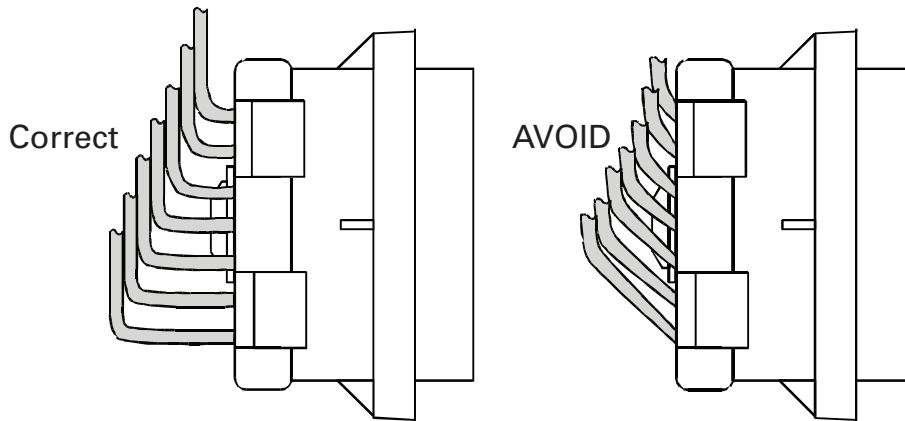

Wire harness bends near a connector must be no less than twice the wire harness diameter. Special consideration shall be given to connectors with large wire counts. Stresses placed upon the retention system of the connector can cause contact retention failures and wire pull-out. In order to avoid this problem consider the following options:

1. Pre-form the harness to the required bend. The harness assembly drawing shall detail the harness bend requirements (e.g. location and radius). The harness braid protection should be applied up to the tangent point of the bend furthest from the connector. Connector orientation to the bend may be necessary and should be specified on the harness print.
2. If harness braiding is used, increase the unbraided harness length to 150 mm. This will allow the wires to fan out when the harness is bent, greatly reducing the forces placed on the connector contact retention system. The connector should also be oriented properly with respect to the harness so that upon installation to the product the harness will not need to be twisted to align the connector.

5.2.6 Drip Loop

When a harness is routed downward to a connector, terminal block, panel, or junction box, a trap or drip loop shall be provided in the harness. This feature will prevent fluids or condensate from running into the above devices.

5.2.7 Sealing Splices and Ring Terminals

Caterpillar requires all ring terminals and splices connected to the engine ECU be sealed using Raychem ES2000 adhesive lined heat shrink tubing or equivalent. Refer to Table 1 for heat shrink tubing sizing information.

Table 1: Heat Shrink Tubing Reference Table

Cat Part Number	I.D. Before Shrink		I.D. After Shrink	
	(mm)	(inch)	(mm)	(inch)
125-7874	5.72	0.225	1.27	0.050
125-7875	7.44	0.293	1.65	0.065
119-3662	10.85	0.427	2.41	0.095
125-7876	17.78	0.700	4.45	0.175

5.2.8 Wire Connection Guidelines

The following requirements ensure the correct installation of solid contacts into connector terminals:

- Do not solder the contact (socket or pin) to the wire.
- Never crimp more than one wire into a contact. Connector contacts are designed to accept only one wire of a specified gauge or gauge range, do NOT insert multiple wires of a smaller gauge.
- All contacts should be crimped on the wires. Use the Crimp Tool (Caterpillar part number 1U-5804) for 12 to 18 AWG wire.
- Perform the pull test on each wire. The pull test is used to verify that the wire is properly crimped in the contact and the contact is properly inserted in the connector terminal. Each contact and connector terminal should easily withstand 45 N (10 lb) of pull such that the wire remains in the connector body.

5.3 Customer Supplied Service Tool Connector (J66) Wiring

A customer-supplied service tool connector is required in applications where the optional Caterpillar customer harness is not utilized. Please note that J63 Service Tool Connectors are similarly wired. However, J63 Service Tool Connectors have been installed and provided by Caterpillar. Cat J63 Service Tool Connectors are typically available as part of an Industrial Price List Optional Attachment called "Harness-ECU Interconnect." The Caterpillar service tool cable (Cat part number 139-4166) has a Deutsch HD 9-position plug connector, thus the customer must supply the mating receptacle on the engine harness.

For an engine compartment-mounted diagnostic connector, Caterpillar recommends grounding the engine data link connector directly to the engine ground stud. It must not be grounded to ECU sensor common connections.

The Caterpillar service tool (Cat ET) communicates with industrial engines via the Cat Data Link (CDL) only. Service tool support is not available on the J1939 data link.

It is recommended that one service tool connector is located in close proximity to the engine, and a second service tool connector is located in the machine cab or at the operator station. Proper wiring of the customer-supplied service tool connector is essential for reliable communications. The maximum length of the Cat Data Link cable is 30 meters (100 ft).

Figure 4 illustrates the pinout location on the Deutsch HD 9-position connector for ease of reference. All customer-supplied wiring shown in Figure 4 is required. This includes power and ground as well as all Cat data link and J1939 data link wiring. Wiring from the ECU to the service tool connector is illustrated in Figure 5. The Cat data link wiring should be twisted two-conductor cable (18 AWG wire) with one twist per 25 mm (approx. 1 inch). Reference Caterpillar service tool cable (part number 143-5018). See section 1.4 for J1939 Data Bus wiring requirements.

NOTE: Industrial engine communication to Cat ET is via Cat Data Link (CDL) only. SAE J1939 data link is not used for Cat ET communication at this time.

Figure 4: Service Tool Connector Pin Locations

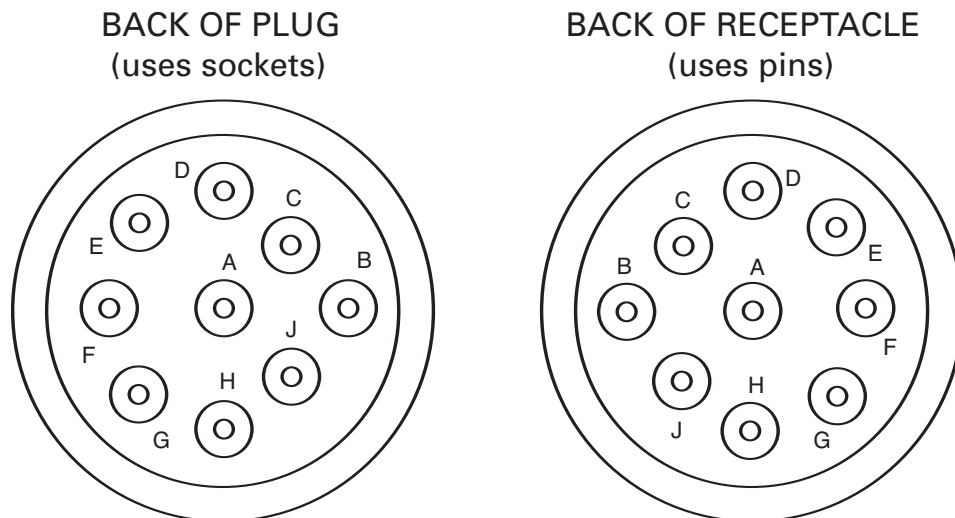
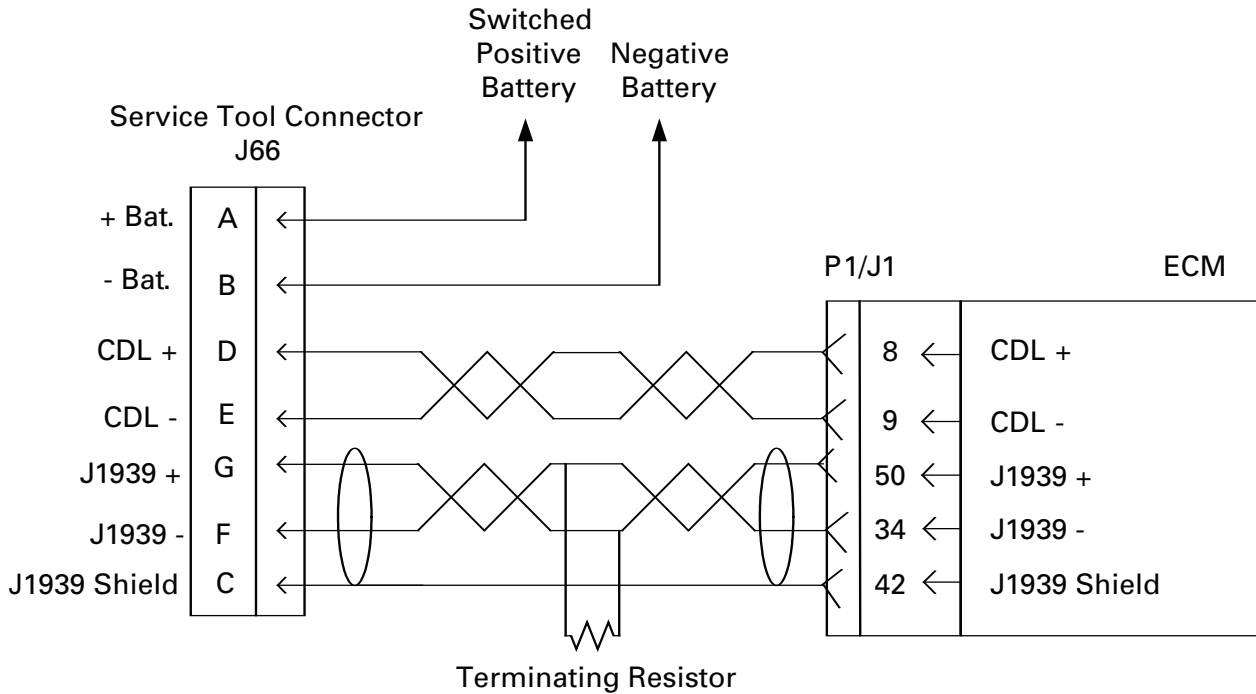

Figure 5: Service Tool Connector Wiring Diagram



NOTE: All 7 wires, J1939, CDL, power and ground as shown in this diagram are required.

5.4 SAE J1939/11 — Data Bus Wiring

5.4.1 J1939 Data Bus Harness Design

The data bus connector that Caterpillar uses is a modified DT connector, special wedge, cable, and extended socket. The harness assembly requirements are unique to typical Caterpillar wire harnesses. Caterpillar recommends 2 conductor shielded cable from Raychem Corp (Raychem part number 2019D0309-0/Cat part number 153-2707) for all J1939 data link wiring. This is twisted pair wiring. If the Caterpillar recommended cable is not used, the cable must meet J1939 specifications for conductors (refer to Table 2). For additional information regarding the electrical system design see the SAE publication J1939/11 "Physical Layer." The minimum bend radius for the data bus cable is 40 mm.

Table 2: J1939 Conductor Specifications

J1939 SPECIFICATIONS FOR CONDUCTORS			
	Minimum	Nominal	Maximum
Impedance (ohm)	108	120	132
Capacitance between conductors (pF/m)	0	40	75
Capacitance between the conductors and the shield (pF/m)	0	70	110

In order that the data bus will function as intended the following requirements must be identified on the customer wire harness print.

1. Remove 75 mm of the outer jacket of data link shielded cable. (Reference Cat part number 153-2707)
2. Remove the foil shield from the exposed wires to within 3 mm of the cable jacket end.
3. Crimp gold-plated socket terminals to the wires and the extended socket terminal to the drain wire.
4. Slide heat shrink tube over the cable end. (Reference Cat part number 125-7876)
5. Install the terminals into the appropriate connector cavity positions.
6. Install the wedge into the connector.
7. Apply the heat shrink tube over the back of the connector body and the jacket of the cable.

The above components and assembly procedures must be used to ensure the cable to connector joint will be sealed. Failure to conform to these requirements will result in cable contamination and result in loss of shield performance. See Figure 6.

Figure 6: SAE J1939 Connector Assembly

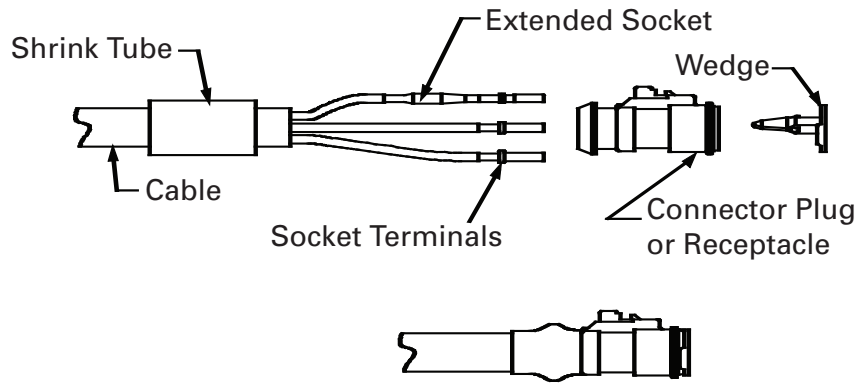

NOTE: Refer to SAE J1939-11 "Physical Layer" document for more information.

5.4.2 Connecting Modules to the CAN Data Link

The SAE J1939 data link is used to communicate engine information to an SAE J1939 compatible display or other desired SAE J1939 compatible modules. Refer to SENR9764 "Installation Guide for Industrial Electronic Engine Displays" for more information on connecting J1939 displays to Caterpillar industrial engines.

The illustration in Figure 7 shows two J1939 modules properly connected to the J1939 data bus. The key components to note are as follows:

- The total length of the data link between terminal resistors must not exceed 40 m (130 ft).
- Length of each branch, or stub length, must not exceed 1 m (3.3 ft). Reference cable assembly (Cat part number 165-0200) that is .15 m long with Deutsch DT 3 pin plug on one end and J1939 signal and shield wires with appropriate crimped socket on the other end for insertion into J1939 module connector.
- All splices and end nodes can be implemented using a connector tee. (Reference Deutsch DT receptacle assembly — Cat part number 133-0970).
- Two terminal resistors must be installed. One resistor is required at each end of the data link in order to ensure proper operation. These two terminal resistors are critical for the proper operation of the network. (Reference Deutsch DT plug with integrated termination resistor — Cat part number 174-3016).

Figure 7: J1939 Multiple Module Installation Example

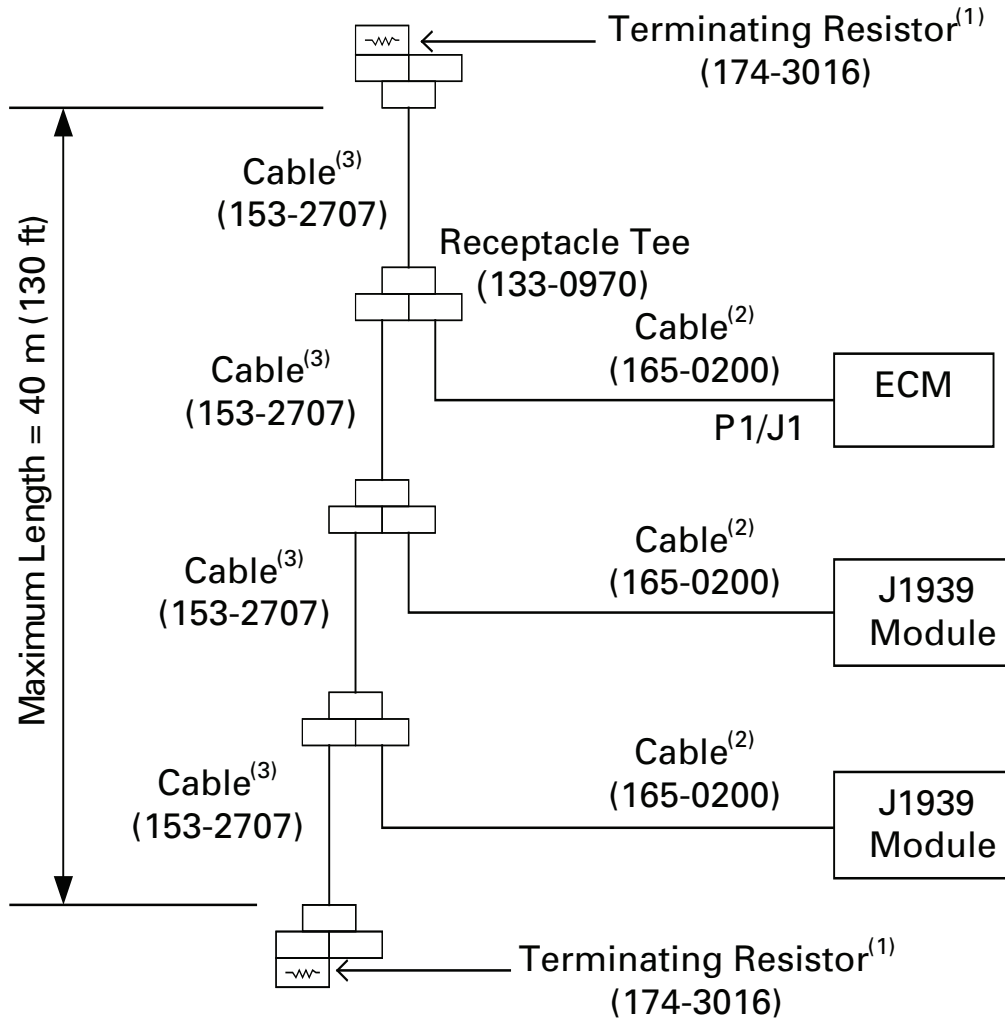

- (1) Two terminal resistors are required Optional Customer Harness provides the resistor at the ECM if installed
- (2) Maximum stub length = 1 m (3.3 ft)
- (3) Fabricate 153-2707 cable to length

NOTE: If the requirements for J1939 data link connections are met, any number of display modules or service tool connectors may be connected to the J1939 data link.

NOTE: One terminal resistor for the J1939 data link is included in the optional customer harness. If the optional customer harness is not present, two terminal resistors must be installed. Any J1939 data link must have a terminal resistor at each end of the data link.

NOTE: A terminal resistor is required at the terminal ends of the data link cable. A terminal resistor is not required at each node on the data link.

6 Customer Equipment I.D. and Passwords

6.1 Equipment Identification

6.1.1 Equipment Identification Operation

Equipment Identification is a configuration parameter that the customer can program in the ECU to uniquely identify an engine installation. Typical uses for the equipment identification parameter include manufacturer model number, machine number, installation location, etc. Configuration of this parameter is optional as the parameter is for customer reference only.

6.1.2 Equipment Identification Configuration

One parameter must be updated with Cat ET to set the equipment ID. The equipment ID defaults to “not programmed” and can be set to a customer-defined identification for the engine. A maximum of 17 characters may be entered in the field. Characters can be any alphanumeric character.

6.2 Customer Passwords

6.2.1 Customer Passwords Operation

Customer passwords are sometimes referred to as “OEM passwords.” Customer passwords may be programmed in order to limit access to certain parameters. There are two customer passwords available. Both customer passwords do not need to be programmed in order to provide protection. If both customer passwords are programmed, then both are required to access and change the password-protected parameters. If a customer password is forgotten or lost, these can be reset, but factory passwords are required to change them.

The following parameters are protected with customer passwords:

- Ether Control
- Ether Configuration
- Throttle Position Sensor
- Air Inlet Heater Installation Status
- Coolant Level Sensor
- Aux Temperature Sensor Installation Status
- Aux Pressure Sensor Installation Status

6.2.2 Customer Passwords Configuration

One or two parameters must be configured in Cat ET prior to using customer passwords:

1. Customer Password #1
2. Customer Password #2

Both passwords default to an empty field. Whether the password is set or not, the display shows “*****”. A maximum of eight alphanumeric characters may be entered for each of the two available customer passwords. These passwords are case sensitive.

6.3 Parameter Lockout

6.3.1 Parameter Lockout Operation

Parameter Lockout changes the protection level of certain parameters from normal Cat ET access to factory password required. If customer passwords are programmed, these will also be required to lock an unlocked parameter in the Parameter Lockout Cat ET screen.

The following configuration parameters can be selected to be locked out:

- High Idle Speed
- Rating Number
- Top Engine Limit
- Maximum Engine Torque Limit
- Intermediate Engine Speed
- Low Idle Speed
- Programmable Monitoring System

6.3.2 Parameter Lockout Configuration

Access the Parameter Lockout screen in the service menu of Cat ET. Customer passwords are required to access this screen if programmed. One or more of the listed configuration parameters can be locked or unlocked in one session. All parameters default to unlocked.

If a locked out parameter must be changed, there are two options:

1. Remove the lockout — In the Parameter Lockout screen, a factory password allows the protection level to be changed back to normal ET access.
2. Retain the lockout — In the Configuration screen, a factory password allows changing the value one time.

7 Factory Configured Parameters

7.1 Engine Serial Number

7.1.1 Engine Serial Number Operation

The engine serial number is programmed in the factory during engine assembly. It is used to identify the engine to electronic monitoring systems and the Cat ET service tool. The programmed engine serial number should match the engine serial number stamped on the engine information plate.

7.1.2 Engine Serial Number Configuration

One parameter must be configured in Cat ET in order to change the engine serial number. The engine serial number defaults to the engine serial number set in the factory. Engine serial number should be programmed to match the engine serial number that is stamped on the engine information plate. If the ECU is replaced, the engine serial number from the engine information plate should be programmed into the new ECU.

7.2 Rating Number

7.2.1 Rating Number Operation

Industrial engine software can support multiple engine ratings in a software flash file. The multiple ratings allow the customer to change the performance and operating characteristics of the engine without changing the engine performance iron. The engine rating and number of ratings supported in the software flash file is specific to a set of engine performance iron. A rating number is assigned to each engine power curve within a software flash file. The rating number is set in the factory to the corresponding number for the rating specified by the customer in the engine order.

NOTE: *The customer should carefully consider the rating required prior to purchase. A rating change after purchase may require an iron update and will incur an up-rate charge for the specified rating or a minimum maintenance fee to update engine documentation.*

7.2.2 Rating Number Configuration

One parameter must be configured in Cat ET in order to change the engine rating. Changing the rating number requires factory passwords. The rating number defaults to the engine rating set in factory and can be set to any other rating supported within the software flash file. The available engine ratings peak torque and rated power are correlated to a rating number that is displayed in the Cat ET configuration screen. All rating changes will result in an up-rate charge for the specified rating or a minimum maintenance fee to update engine documentation.

7.3 FLS (Full Load Setting)

Changing FLS or FTS may void your engine warranty or make your engine non-compliant with applicable emissions regulations. FLS is a number that represents the adjustment to the fuel system that was made at the factory in order to set the engine to a factory-defined nominal power. The correct value for this parameter is stamped on the engine information plate. Factory passwords are required to change FLS. Contact Dealer Support Network prior to changing FLS.

Refer to SEBD9369, Engine News "Responsibilities for Emissions Certified Engines."

7.4 FTS (Full Torque Setting)

Changing FLS or FTS may void your engine warranty or make your engine non-compliant with applicable emissions regulations. FTS is similar to "FLS" in that it is a calibration parameter set at the factory. Factory passwords are required to change FTS. Contact Dealer Support Network prior to changing FTS.

Refer to SEBD9369, Engine News "Responsibilities for Emissions Certified Engines."

8 Customer-Installed Sensors

Customers can install switches, lamps, gauges, displays, and other components on an industrial engine application. Refer to Table 1 and Table 2 in Engine Component Overview (section 2.3) for a complete listing of customer-installed components and the sections in this document where the components are discussed. This section will only cover customer-installed sensors that can be ordered from the industrial engine price list.

Optional sensors that may be installed by the customer include:

- Coolant Level Sensor
- Auxiliary Pressure Sensor
- Auxiliary Temperature Sensor

8.1 Coolant Level Sensor

8.1.1 Coolant Level Sensor Operation

An optional coolant level sensor allows the ECU to monitor the coolant level in the radiator or expansion tank to protect the engine against operation with low or no coolant. The ECU also provides the level status information on the J1939 CAN data link for monitoring and display by off engine devices. Mount the sensor so that it is immersed during all normal operating conditions. If the coolant level sensor is not immersed, then the ECU will take the action configured in the engine monitoring system. The engine must be running at least 60 seconds before any fault condition is triggered. Refer to the coolant level sensor section in Engine Monitoring and Protection (section 15).

8.1.2 Coolant Level Sensor Configuration

One parameter must be configured in Cat ET prior to using a coolant level sensor. In the configuration screen, coolant level sensor defaults to “not installed” and must be set to “installed.”

Programmable monitoring system parameters may be changed to establish the level of protection necessary for the specific installation. Refer to the coolant level sensor section in Engine Monitoring and Protection (section 15).

8.1.3 Coolant Level Sensor Installation

The sensor is supplied with thread sealant on the threads, so it is not necessary to apply thread sealant on a new sensor. If the sensor has been removed, apply pipe sealant (Caterpillar part number 5P-3413) to the threads of the sensor before a reinstallation.

NOTE: Do not splice the sensor signal wire for input to third party devices.

The ECU supplies the sensor with 8 VDC. When coolant is present, the sensor output voltage is approximately 0 VDC (negative battery). When coolant is not present, the sensor output voltage will be greater than 5 VDC. When the sensor is not connected, the voltage on J1/P1 Pin 49 is approximately 12 VDC when referenced to J1/P1 Pin 5.

Recommended connector mounting for component with a pigtail harness:

- The connector interface should never be tied directly to a vibrating member.
- Pigtail wire lead should be tied down on only one side of the connector interface. Choose one of these two locations:
 - midpoint on the sensor pigtail, OR
 - 150 mm from the connector on the harness side.

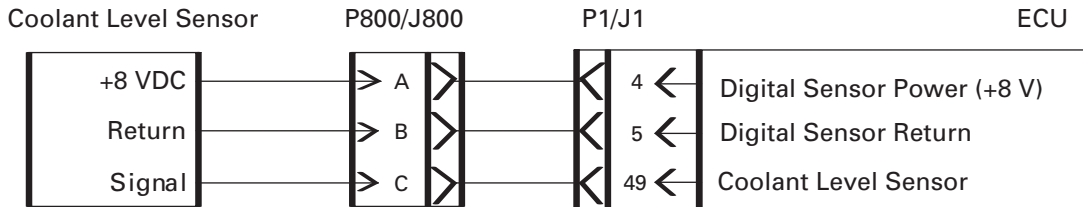

REQUIRED PARTS		
Part Number	Description	Qty
239-9957 ⁽²⁾	Coolant Level Sensor	1
155-2260	Connector Plug Kit	1
9X-3402	Connector Socket	6
N/A	18 AWG Wire	(1)

⁽¹⁾ Fabricated to length

⁽²⁾ 165-6634 was cancelled and replaced by 239-9957

Use of the Caterpillar coolant level sensor is highly recommended. A third-party sensor may not be compatible with the Caterpillar ECU or software. Caterpillar cannot guarantee performance of the any third-party sensor.

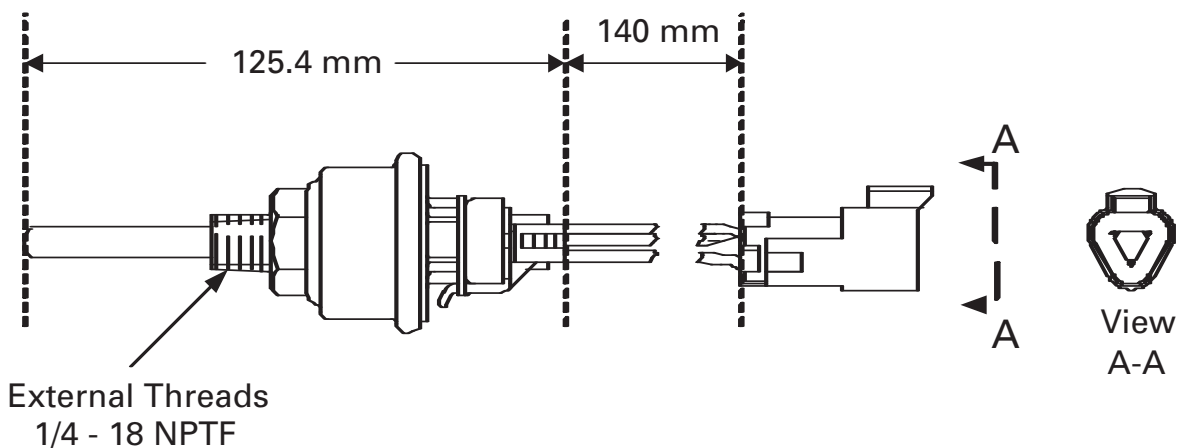

8.2 Auxiliary Pressure Sensor

8.2.1 Auxiliary Pressure Sensor Operation

The auxiliary pressure sensor feature is provided so the engine can monitor any external pressure and provide that pressure information on the J1939 CAN data link. The ECU can also protect the system for excessive pressure by taking any action configured in the engine monitoring system. Refer to the auxiliary pressure sensor section in Engine Monitoring and Protection (section 15).

8.2.2 Auxiliary Pressure Sensor Configuration

One parameter must be configured in Cat ET prior to using an auxiliary pressure sensor. In the configuration screen, Auxiliary Pressure Sensor Installation Status defaults to “not installed” and must be set to “installed.”

Programmable monitoring system parameters may be changed to establish the level of protection necessary for the specific installation. Refer to the auxiliary pressure sensor section in Engine Monitoring and Protection (section 15).

8.2.3 Auxiliary Pressure Sensor Installation

The Caterpillar auxiliary pressure sensor part number must be used in order to accurately measure pressure. Third-party sensors will not be compatible with the hardware and software. The Cat auxiliary pressure sensor is an analog sensor with an operating range of 0 to 3050 kPa (0 to 442 psi).

NOTE: Do not splice the sensor signal wire for input to third party devices.

Recommended connector mounting for component with a pigtail harness:

- The connector interface should never be tied directly to a vibrating member.
- Pigtail wire lead should be tied down on only one side of the connector interface. Choose one of these two locations:
 - midpoint on the sensor pigtail, OR
 - 150 mm from the connector on the harness side.

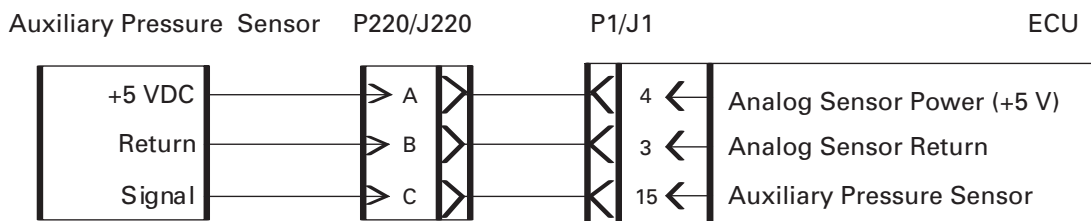

REQUIRED PARTS		
Part Number	Description	Qty
161-9932	Pressure Sensor (Auxiliary)	1
155-2260	Connector Plug Kit	1
9X-3402	Connector Socket	6
N/A	18 AWG Wire	(1)

(1) Fabricated to length

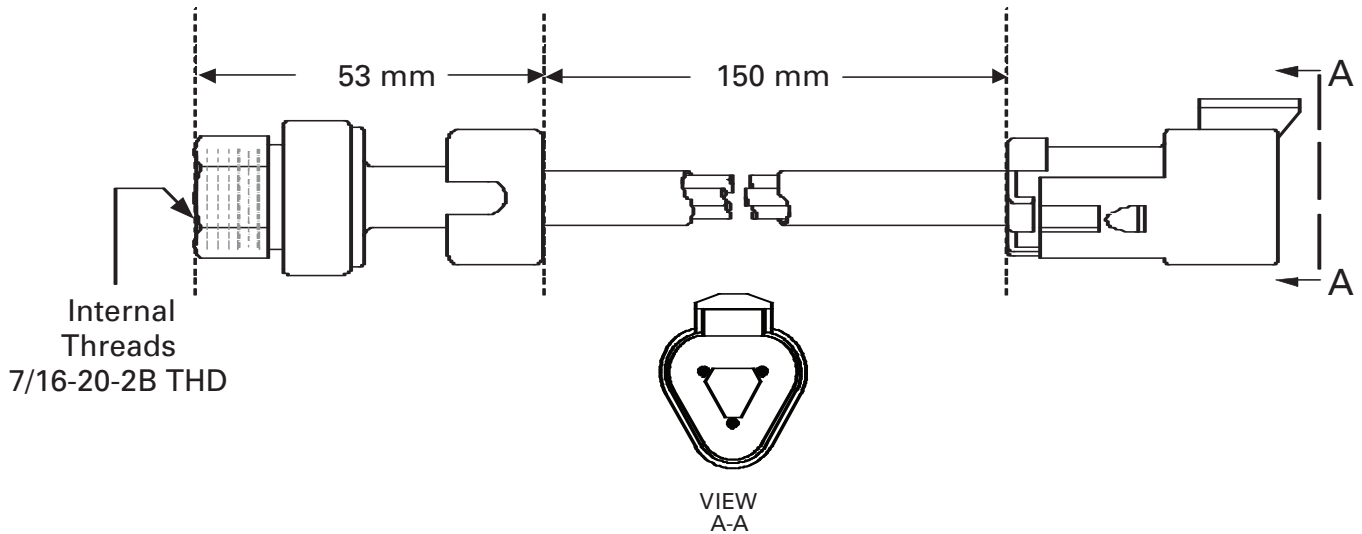

8.3 Auxiliary Temperature Sensor

8.3.1 Auxiliary Temperature Sensor Operation

The auxiliary temperature sensor feature is provided so the engine can monitor any external temperature and provide that temperature information on the J1939 CAN data link. The ECU can also protect the system for excessive temperature by taking any action configured in the engine monitoring system. Refer to the auxiliary temperature sensor section in Engine Monitoring and Protection (section 15).

8.3.2 Auxiliary Temperature Sensor Configuration

One parameter must be configured in Cat ET prior to using an auxiliary temperature sensor. In the configuration screen, Auxiliary Temperature Sensor Installation Status defaults to “not installed” and must be set to “installed.”

Programmable monitoring system parameters may be changed to establish the level of protection necessary for the specific installation. Refer to the auxiliary temperature sensor section in Engine Monitoring and Protection (section 15).

8.3.3 Auxiliary Temperature Sensor Installation

The Caterpillar auxiliary temperature sensor part number must be used in order to accurately measure temperature. Third-party sensors will not be compatible with the hardware and software. The Cat auxiliary temperature sensor is a 0-5 V passive analog sensor with an operating range of -30 to 140°C (-22 to 248°F).

NOTE: Do not splice the sensor signal wire for input to third party devices.

The following harness design and routing guidelines are recommended for best accuracy of passive analog devices:

- Use of gold sockets is strongly recommended
- Sensor wires should be shielded or they should be routed in a separate harness bundle from switching currents that are greater than 100 mA.
- Maximum allowable wire length from the ECU to the sensor is 12 ft (3.65 m).
- Preferred wire gauge is 16 AWG
- The maximum allowable number of connector junctions is two.

Customer-Installed Sensors

Recommended connector mounting for component with a pigtail harness:

- The connector interface should never be tied directly to a vibrating member.
- Pigtail wire lead should be tied down on only one side of the connector interface. Choose one of these two locations:
 - midpoint on the sensor pigtail, OR
 - 150 mm from the connector on the harness side.

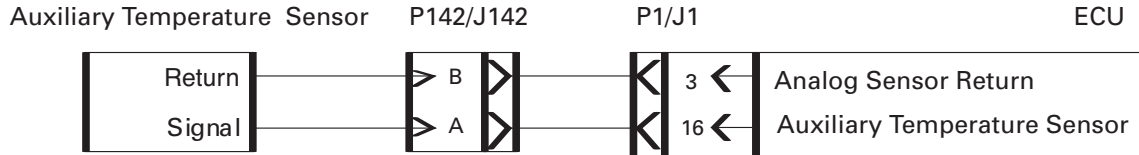

REQUIRED PARTS		
Part Number	Description	Qty
145-7028	Temperature Sensor (Auxiliary)	1
155-2270	Connector Plug Kit	1
9X-3402	Connector Socket (Gold)	4
N/A	16 AWG Wire	(1)

⁽¹⁾ Fabricated to length

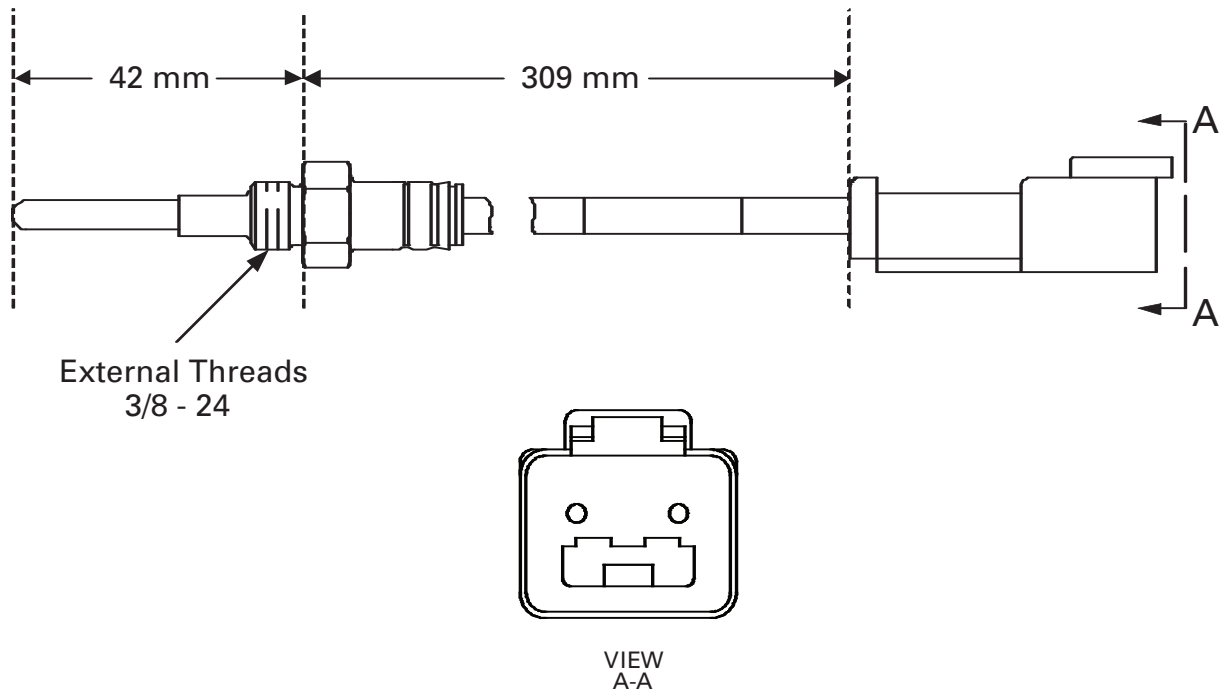

NOTE: Refer to the appropriate Parts Manual for your engine for more information on parts.

9 Starting and Stopping the Engine

9.1 Remote Shutdown Switch

9.1.1 Remote Shutdown Switch Operation

The remote shutdown switch is intended to provide a convenient method of stopping the engine. A ground level remote shutdown switch may be used on large machines, allowing the operator to stop the engine without climbing up to the cab.

On some engines, if the remote shutdown switch is closed to ground, then released, the engine stops. However, if the inertial load keeps the engine turning, the monitoring system will continue to measure sensor outputs (i.e. oil pressure, fuel pressure, etc.) and may record an event code. If the remote shutdown switch is held closed until the engine quits turning, a fault will not be recorded.

When the remote shutdown switch is closed to ground, the ECU disables fuel injection. Under normal conditions, disabling fuel injection stops the engine. However, the remote shutdown switch is not designed to be used as an emergency stop switch. The remote shutdown switch must be opened and the key switch (switched power) must be cycled in order to restart the engine.

NOTE: *The remote shutdown switch is not an emergency stop switch. A large, red, mushroom-type E-stop button should not be used for the remote stop switch. The remote shutdown switch is not designed to be fail-safe. It should not be used to assure the protection of personnel or equipment.*

NOTE: *During a remote shutdown, the air shutoff solenoid is not activated and the ECU remains energized.*

9.1.2 Remote Shutdown Switch Configuration

There is no Cat ET configuration necessary for the remote shutdown switch to function.

9.1.3 Remote Shutdown Switch Installation

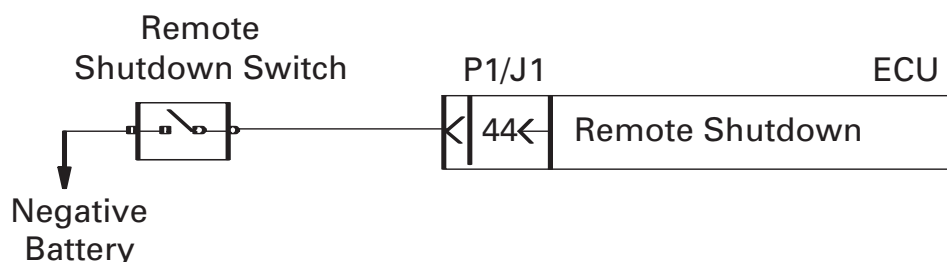

REQUIRED PARTS		
Part Number	Description	Qty
8D-2676	Toggle Switch (spst)	1
9X-3402	Connector Sockets	1
2L-8074	Terminal	2
N/A	18 AWG Wire	(1)

(1) Fabricated to length

9.2 Air Shutoff System

9.2.1 Air Shutoff System Operation

The air shutoff system works in conjunction with the engine overspeed feature. If equipped, an air shutoff system that is controlled by the engine ECU can stop the engine when the engine speed reaches a customer programmed set point. The overspeed verify switch input is available for the customer to test the system at 75 percent of the engine speed configured as the overspeed limit in the engine monitoring system.

When the engine speed exceeds the engine overspeed shutdown value configured in the engine monitoring system, fuel injection will be disabled and the air shutoff solenoid will be activated. Once the air shutoff solenoid is activated, then the key switch (switched power) must be cycled and the air shutoff doors must be manually reset in order to re-start the engine. The air shutoff doors will remain closed until the ECU power has been cycled and the doors have been manually reset.

NOTE: Refer to *Engine Monitoring and Protection (section 15)* for information about the overspeed verify switch.

9.2.2 Air Shutoff System Configuration

One parameter must be configured in Cat ET prior to using air shutoff. In the configuration screen, air shutoff defaults to “disabled” and must be set to “enabled.”

Engine monitoring system parameter for engine overspeed may be changed to establish the level of protection necessary for the specific installation. Refer to the engine overspeed section in *Engine Monitoring and Protection (section 15)*.

9.2.3 Air Shutoff System Installation

Contact the Application Support Center for availability of the air shutoff system hardware. Caterpillar does not offer this hardware on all engine sizes.

NOTE: Source current from the ECU is 2 amps under normal operating conditions. However, under cold operating conditions, the ECU may source as low as 1.0 amp to the relay.

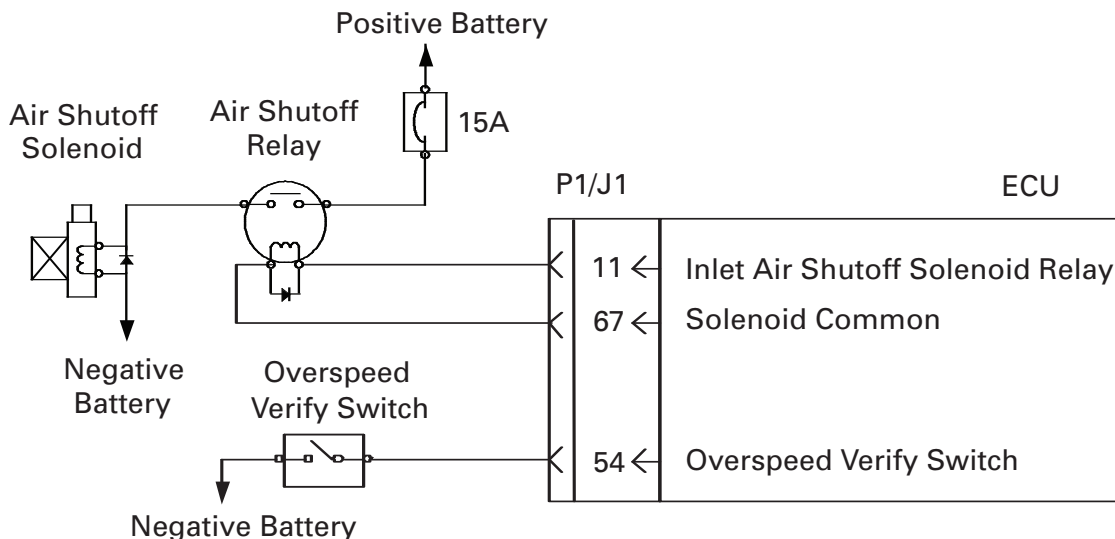

REQUIRED PARTS		
Part Number	Description	Qty
(1)	Air Shutoff System	1
(2)	Relay	1
N/A	Circuit Protection	1
9X-3402	Connector Socket	2
N/A	Terminal (Relay) ⁽²⁾	4
(1)	Terminal (Solenoid)	1
N/A	10 AWG Wire (+ Battery)	(3)
N/A	18 AWG Wire (ECU)	(3)

⁽¹⁾ Refer to the appropriate Parts Manual for your engine.

⁽²⁾ If a third party relay is used, select a relay that will operate between 1.0A and 2.0A.

⁽³⁾ Fabricated to length

9.3 Wait-to-Start (This feature not yet included in all C7/C9 engine software at time of publication)

9.3.1 Wait-to-Start Lamp (C7/C9 engines only) Operation

A Wait-to-Start lamp is provided to support the C7/C9 engine cold start strategy. The operator should not attempt to start the engine when the lamp is illuminated. When the lamp is illuminated, the air inlet heater is on. Refer to air inlet heater operation (Section 16.3.1) for more information.

9.3.2 Wait-to-Start Lamp Configuration

There is no Cat ET configuration necessary for the Wait-to-Start lamp to function.

9.3.3 Wait-to-Start Lamp Installation

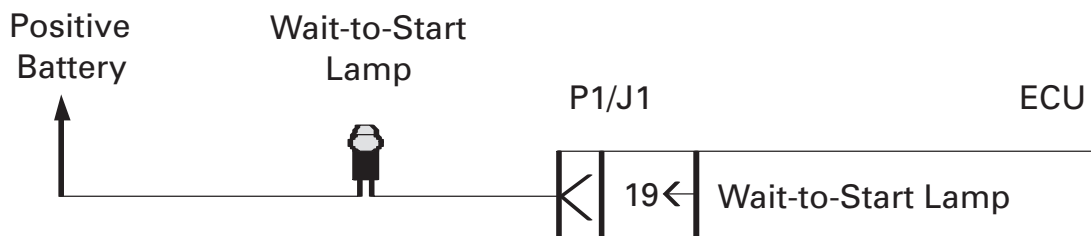

REQUIRED PARTS		
Part Number	Description	Qty
9X-3402	Connector Socket	1
N/A	Lamp	1
N/A	18 AWG Wire (ECU)	(1)

⁽¹⁾ Cut to length

10 Exhaust and Compression Brakes

Exhaust and compression brakes are two forms of engine brake. An engine brake is an auxiliary braking device that essentially turns a diesel engine into air compressor so it absorbs energy instead of producing it. This creates a retarding effect that decreases the engine speed quickly.

10.1 Compression Brake (Available on C15 and C18 Only)

NOTE: *Compression brake cannot be used with all industrial engine models:*

- *C15 — Properly equipped A & B ratings can use a Cat compression brake. C, D, & E ratings CANNOT be used with any compression brake.*
- *C18 — Properly equipped A, B, and C single turbo engines CAN be used with a Cat compression brake. C, D, & E dual turbo ratings CANNOT be used with any compression brake.*

NOTE: *Aftermarket compression brakes are not approved for use on engines covered by this document. Use of these devices VOIDS normal engine warranty.*

A compression brake is a device that attaches to the cylinder head to control exhaust valve position on a piston compression stroke. When enabled, the compression brake holds the exhaust valve open so when the piston descends on what would normally be the power stroke there is no pressure remaining in the cylinder to act on the piston. The engine expends energy to pump air through the engine, thus slowing the engine down drastically. The compression brake also requires a software strategy within the ECU to enable the compression brake and to disable injection when the compression brake is enabled.

Caterpillar offers a Caterpillar designed compression brake as an optional attachment in the Industrial Engine Price List. The Caterpillar compression brake, often referred to as Cat Brake, includes a brake actuator assembly, wiring harness from ECU to brake actuator solenoids, and ECU brake strategy support in the software. The Cat Brake components are installed and tested in the factory when ordered with the engine. Please contact your local Caterpillar dealer for assistance if a compression brake is desired and the engine was NOT ordered with the factory-installed Cat compression brake.

10.1.1 Compression Brake Operation

The Caterpillar compression brake system has one brake actuator assembly per pair of adjacent cylinders. Each brake actuator assembly has one electronically controlled solenoid valve that, when energized, allows the brake actuator to open the exhaust valve for the cylinder that is on its compression stroke. The solenoid valve is controlled directly by a current driver output on the ECU. The Caterpillar compression brake strategy allows one, two, or three brake actuator assemblies to be activated, resulting in two, four, or six cylinder progressive braking.

The ECU software supports the progressive braking strategy by providing four levels of engine braking: Off, Low (two cylinders), Medium (four cylinders), and High (six cylinders). The customer wiring to the “retarder solenoid LO/Hi and MED/Hi” switch inputs on the ECU determines the level of engine braking. The ECU compression brake strategy uses the braking level setting and current engine operating conditions to determine when and which brake actuator to activate.

The compression brake can only be engaged if all of the following conditions are met:

- The engine is NOT in cold mode
- Desired engine speed is equal to LOW IDLE
- Actual engine speed is greater than 1000 rpm
- The engine has a valid speed/timing sensor signal
- There are no diagnostic codes on the throttle signal

The compression brake can be used with the intermediate speed switch enabled or with the PTO switch enabled as long as the resulting desired engine speed is equal to the low idle speed.

The compression brake will be turned off or disabled if any of the following conditions are met during compression brake operation:

- Actual engine speed falls below 950 rpm
- Desired engine speed does not equal LOW IDLE
- The ECU detects a speed/timing sensor diagnostic code
- The ECU detects a throttle signal diagnostic code

NOTE: At publication, compression brake control is not supported for the J1939 data link.

10.1.2 Compression Brake Configuration

Two parameters must be configured in Cat ET prior to using a compression brake.

1. Engine Retarder Enable Command defaults to “disabled” and must be set to “enabled.”
2. Low Idle Speed defaults must be configured to less than or equal to 900 rpm.

10.1.3 Compression Brake Installation

NOTE: The use of a compression brake requires a specific iron set from Caterpillar. Prior to completing installation, ensure that the engine is properly equipped. For more information, consult with the Application Support Center.

Customer installation of the Caterpillar compression brake system requires the following ECU connections:

The two switches connected to the “retarder solenoid LO/HI and MED/HI” inputs on the ECU use the logic input in the following table to determine the level of engine braking to be used by the compression brake control strategy.

COMPRESSION BRAKE SWITCH LOGIC TABLE		
Level	LO/HI	MED/HI
Off	Open Circuit	Open Circuit
Low	Short Circuit	Open Circuit
Medium	Open Circuit	Short Circuit
High	Short Circuit	Short Circuit

Exhaust and Compression Brakes

If the engine is ordered with the factory-installed Cat compression brake, the only additional components needed are:

1. a retarder solenoid selector switch
2. retarder solenoid ON/OFF Switch
3. a retarder lamp

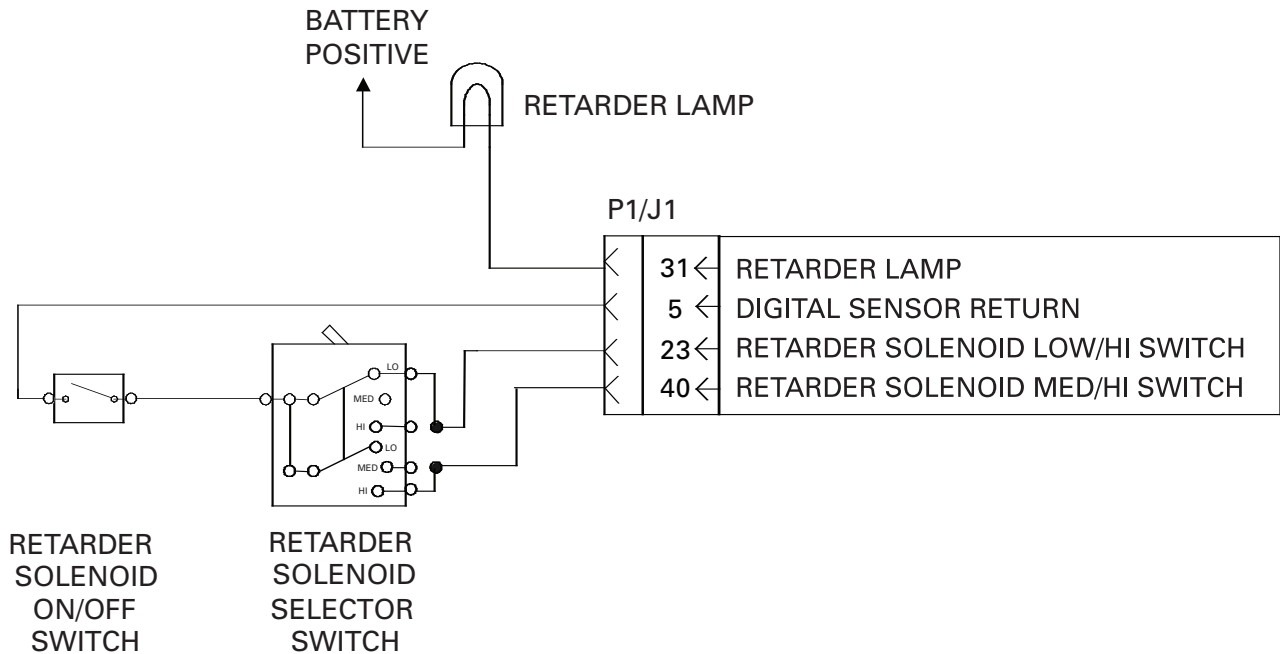

10.2 Exhaust Brake (Available on C7 and C9 Only)

10.2.1 Exhaust Brake Operation

NOTE: At the time of publication, exhaust brake is not available. Exhaust brake is scheduled to be available late 2006.

An exhaust brake, or exhaust retarder, is an auxiliary braking device designed to decrease engine speed. The exhaust brake is a device that restricts exhaust flow downstream of the turbocharger outlet. As the device restricts the flow of exhaust gas, exhaust backpressure at the engine increases, and the piston meets resistance as it tries to push the gases past the brake, resulting in rapid deceleration.

NOTE: Use of an exhaust brake must not exceed the engine's specified exhaust backpressure limit.

10.2.2 Exhaust Brake Modes of Operation

There are two modes of exhaust brake operation:

1. Vehicle Brake Mode
2. Overspeed Protection Mode

10.2.2.1 Vehicle Brake Mode Operation

The engine ECU controls the exhaust brake through a relay. If the exhaust brake enable switch input is in the ON position, then the exhaust brake will be used to brake the vehicle as intended.

The vehicle brake mode will activate when all of the following conditions are met:

- Engine speed is greater than the sum of the desired speed (commanded speed) plus the offset speed. Offset speed is the amount of engine rpm above low idle that will activate the exhaust brake.
- Desired engine speed (commanded speed) is low idle
- The fuel position shown in the Cat ET status screen is less than 2 cubic millimeters in quantity

The vehicle brake mode will not be activated under the following conditions:

- Key switch is in the OFF position
- Remote shutdown has been activated
- An engine monitoring system shutdown has occurred
- An active exhaust brake relay driver diagnostic code

10.2.2.2 Overspeed Protection Mode Operation

The exhaust brake can be used as an engine overspeed protection device. The engine ECU controls the exhaust brake through a relay. If the exhaust brake enable switch input is in the OFF position, then the exhaust brake will be used to protect the engine during an overspeed condition.

The overspeed protection mode will activate when all of the following conditions are met:

- Exhaust brake enable switch input is in the OFF position
- Engine speed is greater than the programmed overspeed trip point
- The fuel position shown in the Cat ET status screen is less than 2 cubic millimeters in quantity

The overspeed protection mode will not be activated under the following conditions:

- Key switch is in the OFF position
- Remote shutdown has been activated
- An engine monitoring system shutdown has occurred
- An active exhaust brake relay driver diagnostic code

10.2.3 Exhaust Brake Configuration

10.2.3.1 Vehicle Brake Mode Configuration

Two parameters must be configured in Cat ET prior to operating in vehicle brake mode.

1. Exhaust Valve Actuation System Installation Status defaults to “uninstalled” and must be set to “installed.”
2. “Offset Speed” defaults to 150 rpm and can be programmed between 50 rpm and 500 rpm.

Offset speed = [the trip point at which the exhaust brake will be activated] - [low idle]

10.2.3.2 Overspeed Protection Mode Configuration

Two parameters must be configured in Cat ET prior to operating in overspeed protection mode.

1. Exhaust Valve Actuation System Installation Status defaults to "uninstalled" and must be set to "installed."
2. Overspeed Trip Speed defaults to 2800 rpm and can be programmed between high idle and PMS max overspeed trip point.

10.2.4 Exhaust Brake Installation

The ECU will source 2.0 amps to drive the exhaust brake relay at normal operating conditions. At cold operating conditions, the ECU may source as low as 1.0 amp to the relay. If a third-party relay is used, select a relay that will operate between 1.0 A and 2.0 A.

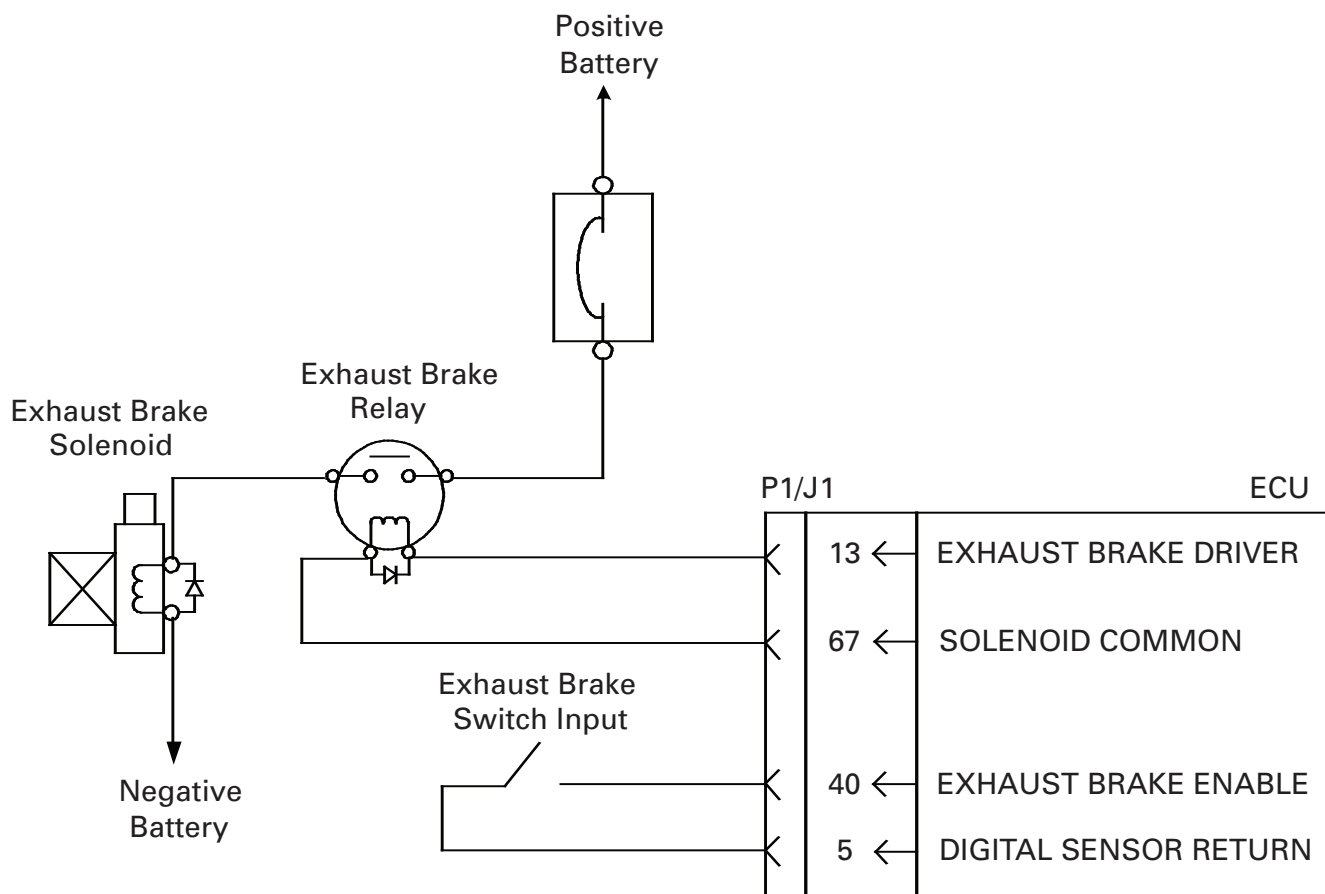

11 Engine Speed Demand

There are several options available to set the desired engine speed used by the control system to control engine speed. The application requirements determine which option, or combination of options, should be selected.

Following are the different methods of controlling the speed of the engine:

- Throttle Position Sensor
- Intermediate Engine Speed Switch
- PTO Mode
- J1939 Speed Control (TSC1)
- ET Override (Dyno Test Mode)

11.1 Throttle Position Sensor (TPS)

11.1.1 TPS Operation

The Throttle Position Sensor (TPS) replaces a mechanical throttle and governor linkages. The TPS delivers an electrical signal to the ECU. The TPS signal and the engine speed/timing signal are interpreted by the ECU to precisely control engine speed. Caterpillar requires a TPS that generates a Pulse Width Modulation (PWM) signal.

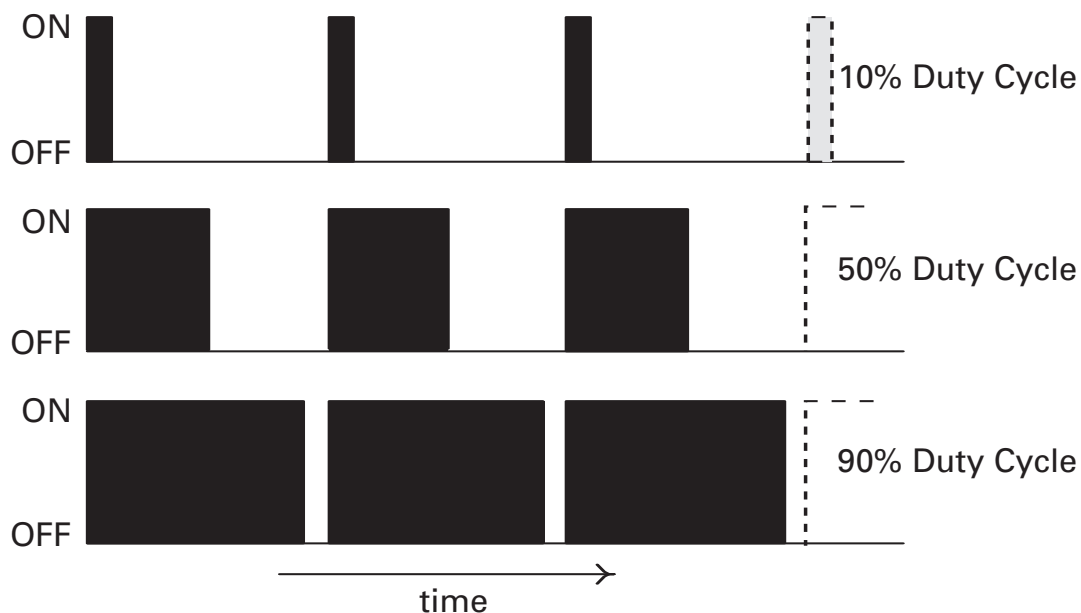

A PWM signal is a square wave. A square wave signal is either full voltage or no voltage — ON or OFF. The percent of time the signal is ON versus the total time is called the duty cycle. Refer to the ECU Interface Requirements section in the Appendix for more information on PWM signal interface requirements with the ECU.

A TPS converts a physical position into a PWM signal. The TPS moves between its minimum and maximum throttle positions, or low idle and high idle positions. When the TPS is at low idle, the TPS generates a PWM signal that is typically 10-15 percent duty cycle. When the TPS is at high idle (maximum travel position), the TPS generates a PWM signal that is typically 85-90 percent duty cycle.

Two programmable parameters are provided in order for the ECU to interface with any PWM TPS. These two parameters are Throttle Input High Idle Duty Cycle and Throttle Input Low Idle Duty Cycle.

- When the ECU receives a PWM signal from the TPS less than or equal to the programmed value for throttle input low idle duty cycle, the engine will govern speed at the programmed value for engine low idle.
- When the ECU receives a PWM signal from the TPS greater than or equal to the programmed value for throttle input high idle duty cycle, the engine will go to full engine speed as dictated by Top Engine Limit (TEL) and high idle programmable parameters.
- The ECU will interpret throttle signals between a PWM duty cycle of 5 percent or less, or 95 percent or more, as invalid and consequently the engine will default to low idle and log a diagnostic code. This is referred to in the PWM throttle set-up diagram (Figure 5) as the upper and lower diagnostic zone.

Figure 4: Throttle Position Sensor Parameter Diagram

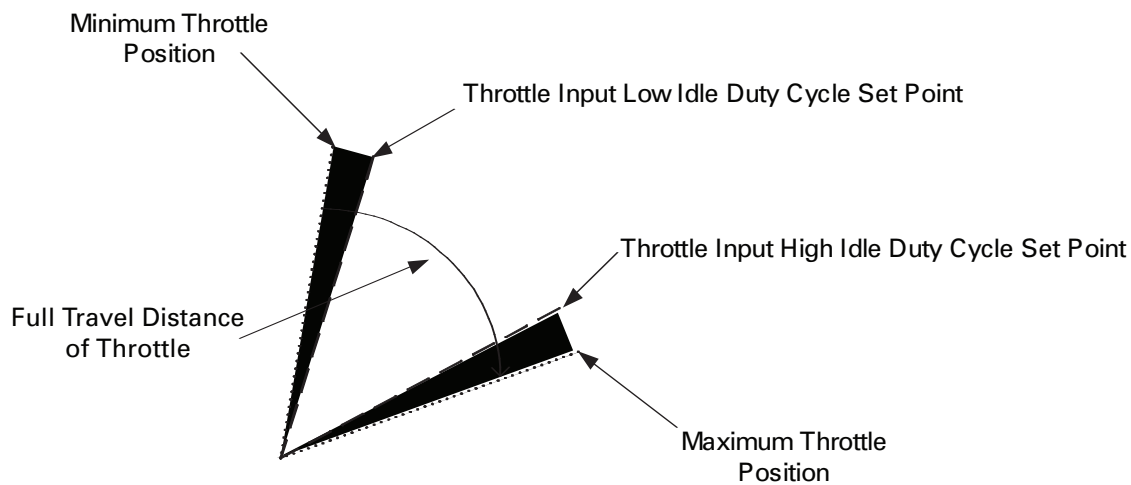

NOTE: *The relationship of engine speed to PWM duty cycle may not be perfectly linear.*

11.1.2 TPS Configuration

Three parameters must be configured in Cat ET prior to using a PWM TPS.

1. TPS programmed to "installed"
2. Throttle Input Low Idle Duty Cycle defaults to 10, can be set from 10 to 4 percent (refer to PWM throttle set-up procedure below to determine proper settings)
3. Throttle Input High Idle Duty Cycle defaults to 90, can be set from 50 to 90 percent (refer to PWM throttle set-up procedure below to determine proper settings)

NOTE: *In previous models, engines used a parameter called desired speed input configuration. This parameter is no longer required.*

PWM Throttle Set-Up Procedure

- Step 1.** Connect the customer TPS to the engine according to the graphic in TPS Installation (section 11.1.3). Connect with Cat ET to the engine. Locate “Throttle Input Duty Cycle” in the Cat ET status screens. It will most likely be status screen 6, but the status screen number can vary depending upon engine model and Cat ET version.
- Step 2.** Be sure the throttle is in the low idle position. It may be necessary to twist against stop or to pull up on a foot pedal, etc. Note the value shown for “Throttle Input Duty Cycle.”
- Step 3.** Add 5 to the “Throttle Input Duty Cycle” value. The sum is the proper value of “Throttle Input Low Idle Duty Cycle.” Write down the value.
- **Note:** *This value cannot be less than 10 percent or greater than 40 percent.*
 - Adding 5 provides a tolerance (deadband) for wear and mechanical variations.
- Step 4.** Be sure the throttle is in the high idle position. It may be necessary to twist against stop or to push down on a foot pedal, etc.). Note the value shown for “Throttle Input Duty Cycle.”
- Step 5.** Subtract 5 from the “Throttle Input Duty Cycle” value. The difference is the proper value of “Throttle Input High Idle Duty Cycle.” Write down the value.
- **Note:** *This value cannot be greater than 90 percent or less than 50 percent.*
 - Subtracting 5 provides a tolerance (deadband) for wear and mechanical variations.
- Step 6.** Enter the values for the two parameters into the configuration screen in ET.

Figure 5: PWM Throttle Set-Up Diagram

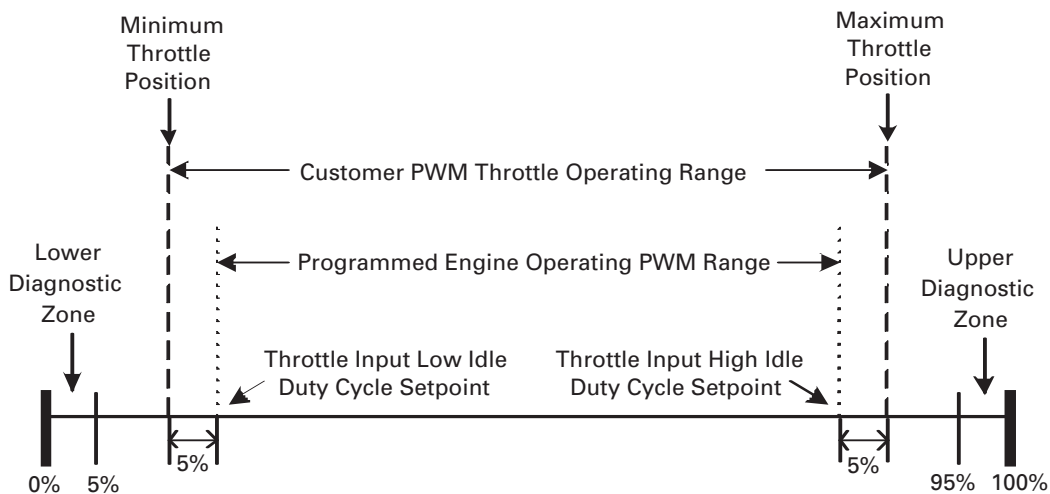

11.1.3 TPS Installation

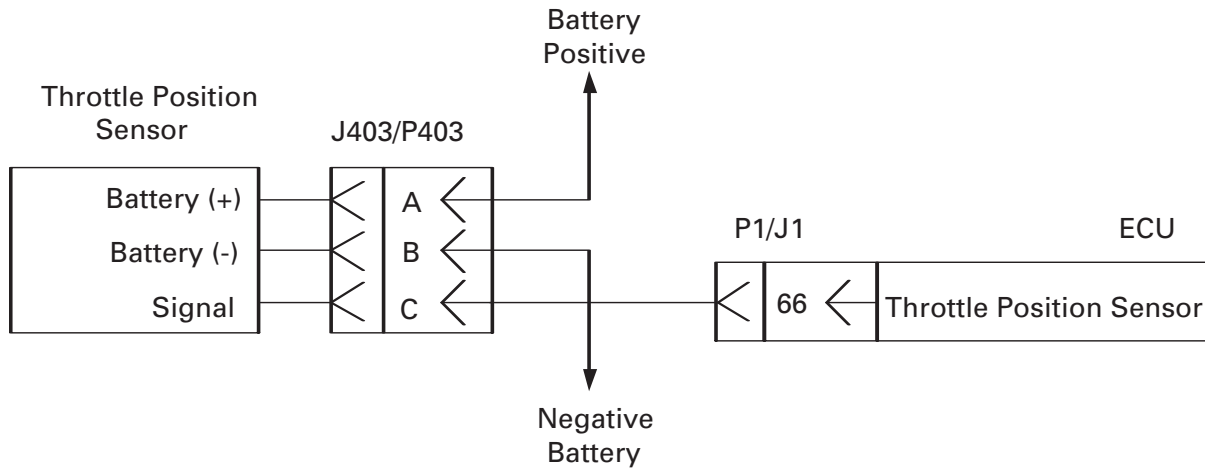

11.2 Dual Throttle Position Sensors

Dual throttle is not available at this time.

11.3 Intermediate Engine Speed

11.3.1 Intermediate Engine Speed Operation

Intermediate engine speed is a feature that can control engine speed to a single set speed by closing one switch to ground input. The set speed can be any speed from low idle speed to TEL.

The intermediate engine speed switch overrides all other engine speed commands. When the intermediate engine speed switch is closed, the engine speed will increase or decrease to achieve the programmed set speed. Engine speed will increase or decrease at the rate defined by the programmed value for engine accel. rate. When engine speed reaches the programmed value, it will govern at exactly that speed unless the engine is overloaded and thus sent into a lug condition. When the intermediate engine speed switch is opened, the engine will immediately revert back (not using engine accel. rate) to any other throttle input signal, or to low idle speed if no other signal is present.

For example, if a throttle position sensor signal is requesting desired engine speed to be different than intermediate engine speed (higher or lower), then (when the intermediate engine speed switch is opened) the engine will accelerate or decelerate immediately (not using the programmed value for engine accel. rate) to that higher or lower speed. If no other engine speed signal is present, the engine will go immediately to low idle.

NOTE: *Engine accel. rate is an rpm per second value and is used for both acceleration and deceleration for both intermediate engine speed and PTO functions.*

11.3.2 Intermediate Engine Speed Switch Configuration

Two parameters must be configured in Cat ET prior to using intermediate engine speed.

1. Intermediate Engine Speed defaults to 1100 rpm; set to the customer's desired speed. The parameter configuration range is from low idle speed to TEL.
2. Engine Acceleration Rate defaults to 500 rpm per second. It can be set from 10 to 1000 rpm per second. Acceleration/deceleration rate should be considered prior to using this feature. This acceleration rate also applies to PTO modes.

NOTE: PTO functions and intermediate speed switch will not work if the min/max governor is selected.

NOTE: When intermediate speed switch is opened, the engine WILL NOT decelerate at the engine accel. rate. Rather, it will immediately drop to low idle or to speed dictated by any other throttle input device that is lower than the programmed intermediate speed.

11.3.3 Intermediate Engine Speed Switch Installation

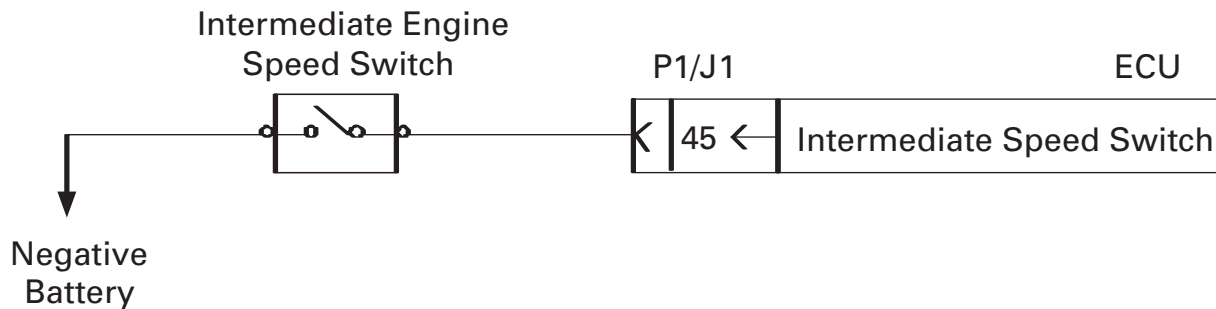

REQUIRED PARTS		
Part Number	Description	Qty
N/A	Toggle Switch (SPST)	1
9X-3402	Connector Socket	1
2L-8074	Terminal	2
N/A	18 AWG Wire	(1)

⁽¹⁾ Fabricated to length

11.4 J1939 Speed Control (TSC1) (Data Link Command)

11.4.1 J1939 Speed Control (TSC1) Operation

J1939 CAN speed control is available via the J1939 data link (TSC1 modes 1 and 3). J1939 CAN data link engine speed control signals will override any engine speed control signal with the exception of intermediate engine speed.

11.4.2 J1939 Speed Control Configuration

There is no configuration required in order to use J1939 speed control. Previous model engines used a parameter called desired speed input configuration. This parameter is no longer required. Refer to J1939 Section for more detail on the J1939 CAN TSC1 message.

11.4.3 J1939 Speed Control Installation

If a customer requires engine control through the SAE J1939 data link, the data link wiring must be properly installed. See the Connectors and Wiring Harness Requirements section for proper data link installation information.

11.5 Power Take Off (PTO) Ramp Up/Down Mode

NOTE: *PTO functions and intermediate speed switch will not work if torque control is selected in the engine primary governor mode.*

11.5.1 PTO Ramp Up/Down Mode Operation

PTO ramp up/ramp down mode uses three switch to ground inputs to enable and control PTO speed demand setting. PTO ramp up/ramp down requires a PTO enable switch. This switch allows PTO ramp up/ramp down to be enabled or disabled. If the PTO enable switch is opened at any speed, the engine will immediately (not using engine accel. rate) revert back to TPS signal or to low idle speed (if a TPS signal is not present).

PTO ramp up/ramp down speed control allows for engine speed to be increased using a single pole, double throw, momentary switch (or a non-momentary type as well). If the switch is held in the ramp up position, the engine will accelerate toward full speed at the programmed engine accel. rate. If the switch is returned to the centered position at any time during the acceleration, engine speed will stabilize and govern at that speed. If the switch is held permanently in position, the engine will achieve and maintain full speed as per top engine limit and high idle parameters. If the switch is held in the ramp down position, the engine will decelerate at the programmed engine accel. rate toward low idle speed. If the switch is returned to the centered position at any time during the deceleration, engine speed will stabilize and govern at that speed.

PTO ramp up/ramp down will be overridden by intermediate engine speed or J1939 speed control. If PTO ramp up/ramp down and a TPS are used, then the ECU will choose the higher of the two speed signals.

NOTE: *Engine accel. rate is an rpm per second value and is used for both acceleration and deceleration for both intermediate engine speed and PTO functions.*

NOTE: *PTO strategy will latch the current speed setting if ramp up/ramp down inputs are selected at the same. This condition will remain until PTO enable switch is cycled.*

11.5.2 PTO Ramp Up/Down Mode Configuration

Two parameters must be configured in Cat ET prior to using PTO ramp up/down.

1. PTO Mode defaults to Ramp Up/Ramp Down. No change is required.
2. Engine Acceleration Rate defaults to 500 rpm per second. It can be set from 10 to 1000 rpm per second. Acceleration/deceleration rate should be considered prior to using this feature. This acceleration rate also applies in intermediate engine speed.

11.5.3 PTO Ramp Up/Down Mode Installation

Refer to the PTO ramp up/ramp down switch status truth table (Table 4) for an overview of the PTO ramp up/ramp down operation for the different switch input state combinations. Following are general tips to consider when wiring to the switch inputs:

- If PTO ramp up/ramp down is the only means of controlling engine speed, the PTO enable circuit may be wired directly to the battery negative.
- P1/J1 Pin 56 or 58 may be switched to battery negative for extended periods of time if the method of control is simply to provide either high idle or low idle.
- If Pin 58 and 60 are both connected to ground at the same time the engine will maintain the current speed and will not allow speed changes until the PTO enable input, Pin 56, is cycled.

Table 4: PTO Ramp Up/Ramp Down Switch Status Truth Table

Switch Status			Speed Demand Status
PTO Enable	Ramp Up	Ramp Down	
Open	Any	Any	Set to the valid throttle speed
Close	Open	Open	Remain at current desired engine speed
Close	Open	Close	Ramp down
Close	Close	Open	Ramp up
Close	Close	Close	Invalid combination — latch speed

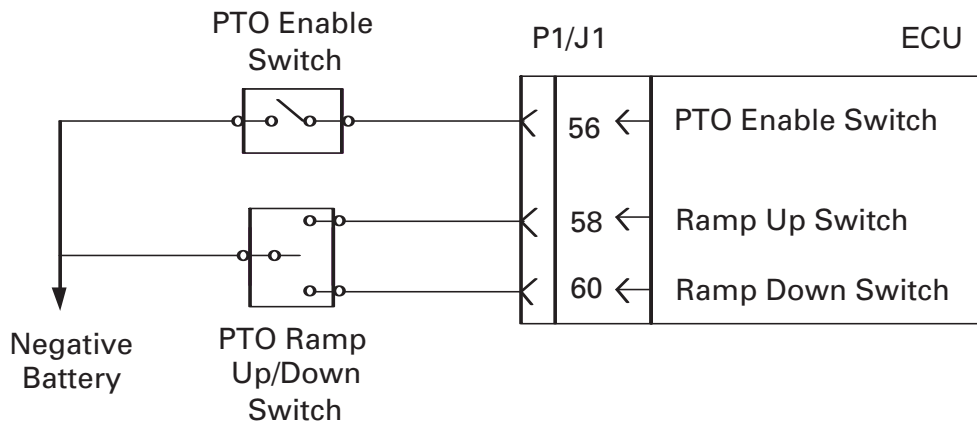

REQUIRED PARTS		
Part Number	Description	Qty
N/A	Toggle Switch (SPST)	1
N/A	Toggle Switch (SPDT Momentary)	1
9X-3402	Connector Socket	3
N/A	Terminal	5
N/A	18 AWG Wire	(1)

⁽¹⁾ Fabricated to length

11.6 PTO Set/Resume Mode

NOTE: PTO functions and intermediate speed switch will not work if torque control is selected in the engine primary governor mode.

11.6.1 PTO Set/Resume Mode Operation

PTO Mode 2: Set/Resume/Interrupt uses four switch inputs to enable and control PTO speed demand setting. PTO set/resume speed control allows for the same control, using the same single pole, double throw, momentary switch as PTO ramp up/ramp down. However, PTO set/resume also allows for more functionality, using momentary inputs in either direction as well as an additional input for interrupting the set speed.

PTO set/resume requires a PTO enable switch. When this switch is closed, PTO ramp up/ramp down functionality becomes available. If the PTO enable switch is opened at any speed, the engine will do two things.

1. Immediately (not using engine accel. rate) revert back to TPS signal or to low idle (if a TPS signal is not present).
2. Lose any engine speed setting which was previously set.

If the set switch is momentarily held (toggled) in the set position, the desired engine speed will be set to the current engine speed. After the desired engine speed is set, toggling the set switch will increase engine speed in increments of 20 rpm.

NOTE: The engine speed set in this fashion is not retained during a key switch power cycle.

If the PTO interrupt switch is opened, engine speed will immediately drop (not using engine accel. rate) to low idle or to the TPS speed signal. However, engine speed prior to opening the interrupt is retained for the next resume cycle.

Last, momentarily toggling the resume switch will send the engine back to the last known value for engine speed using the engine accel. rate.

PTO ramp set/resume will be overridden by intermediate engine speed or J1939 speed control. If PTO ramp set/resume and a TPS are used, then the ECU will choose the higher of the two speed signals.

11.6.2 PTO Set/Resume Mode Configuration

Two parameters must be configured in Cat ET prior to using PTO ramp up/ramp down.

1. PTO Mode defaults to Ramp Up/Ramp Down. It must be programmed to Set/Resume.
2. Engine Acceleration Rate defaults to 500 rpm per second. It can be set from 10 to 1000 rpm per second. Acceleration/deceleration rate should be considered prior to using this feature. This acceleration rate also applies in intermediate engine speed.

11.6.3 PTO Set/Resume Mode Installation

Refer to the PTO set/resume switch status truth table (Table 5) for an overview of the PTO ramp up/ramp down operation for the different switch input state combinations. Following are general tips to consider when wiring to the switch inputs:

- If the PTO is the only means of controlling engine speed, the PTO enable circuit may be wired directly to the negative battery.
- If Pin 58 and 60 are both connected to ground at the same time the engine will maintain the current speed and will not allow speed changes until the PTO enable (Pin 56) input or PTO interrupt (Pin 41) is cycled.
- If Pin 58 and 60 are both connected to ground at the same time the engine will maintain the current speed and will not allow speed changes until the PTO enable input, Pin 56, is cycled.

Table 5: PTO Set/Resume Switch Status Truth Table

Switch Status				Speed Demand Status
PTO Enable	PTO Interrupt	Set/Ramp Up	Resume/Ramp Down	
Open	Any	Any	Any	Set to valid throttle speed
Close	Open	Any	Any	Switch from PTO to valid throttle speed
Close	Close	Open	Open	Enable PTO mode
Close	Close	Open	Close	Resume PTO set speed/ramp down
Close	Close	Close	Open	Set PTO speed/ramp up
Close	Close	Close	Close	Invalid combination — latch speed

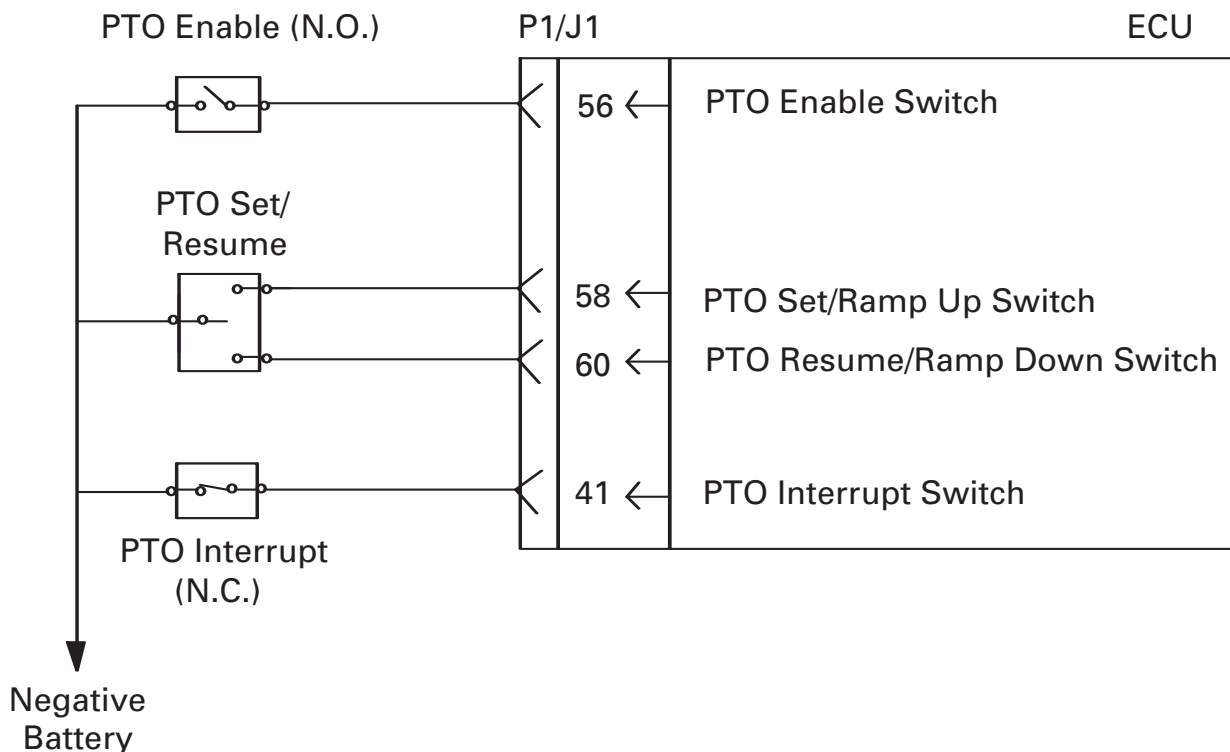

REQUIRED PARTS		
Part Number	Description	Qty
N/A	Toggle Switch (SPST)	2
N/A	Toggle Switch (SPDT, Momentary)	1
9X-3402	Connector Socket	4
N/A	Terminal	7
N/A	18 AWG Wire	(1)

⁽¹⁾ Fabricated to length

11.7 ET Override (Dyno Test Mode)

The ET override (dyno test mode) is only for engine test purposes. This feature may not be supported by all versions of ET.

11.8 Low Idle Speed

11.8.1 Low Idle Speed Operation

Low Idle Speed is a programmable parameter that allows the customer to program the engine's low idle speed. Low idle speed is the minimum allowable operating speed for the engine.

11.8.2 Low Idle Speed Configuration

One parameter must be configured in Cat ET in order to program low idle speed. Low idle speed must be set to the customer's desired minimum operating speed. Typically Low Idle defaults to 700 rpm and can be programmed from 600 to 1400 rpm.

11.9 Top Engine Limit (TEL)

11.9.1 Top Engine Limit (TEL) Operation

Top Engine Limit (TEL) is a programmable parameter that allows the engine's full load (rated hp) speed to be programmed within the top engine speed range. Top engine speed range is displayed on the configuration screen in Cat ET. This top engine speed range has a lower and upper limit and will span either 300 or 400 rpm. It is important to consider that TEL and high idle (another programmable parameter) work together to determine the overrun* portion of the power curve. The overrun portion of the power curve will change as TEL and high idle are modified. The slope of the overrun curve will be determined by the difference between TEL and high idle. Refer to the Engine Governing for more information on engine operation between TEL and high idle speed.

* Some other common terms for overrun are "run out" or "governor curve."

NOTE: TEL is not programmable on agriculture engine ratings.

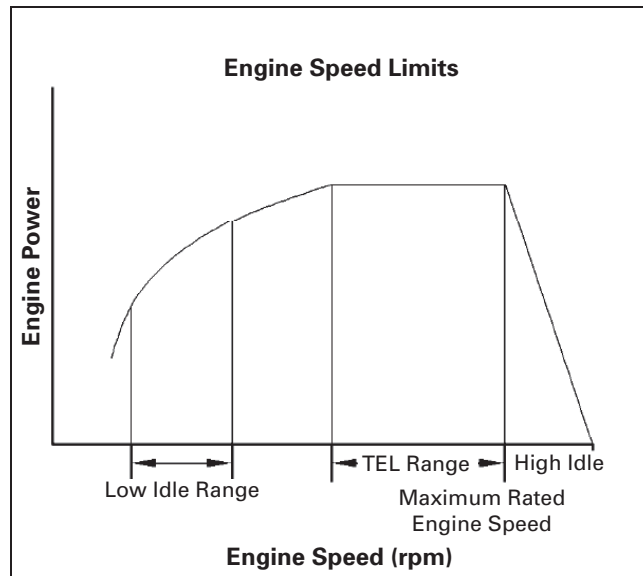

11.9.2 Top Engine Limit (TEL) Configuration

If the customer wants the engine's full load (rated hp) speed to be equal to the high side of the top engine speed range, then no configuration is necessary. The engine will always default to the highest engine speed in the top engine speed range.

If the customer wants TEL to be reduced from the highest engine speed in the top engine speed range, then two parameters must be configured in Cat ET.

1. Run Out Control must be configured to "ON." The key switch (switched power) must be cycled in order to change TEL. Otherwise, TEL will remain unavailable. If Run Out Control is "OFF," then TEL will appear as "UNAVAILABLE" in the ET Configuration screen.
2. Top engine limit must be changed to the customer's desired full load (rated hp) speed. This desired speed must be within the top engine speed range displayed in Cat ET.

11.9.3 Top Engine Limit (TEL) Installation

No installation is necessary.

11.10 High Idle Speed

11.10.1 High Idle Speed Operation

High Idle Speed is a programmable parameter that allows the engine's no load (zero hp) maximum speed to be programmed. The high idle speed parameter applies when controlling engine speed with either PTO functionality or a TPS.

High idle speed must meet two criteria:

- Equal to or greater than TEL
- Less than or equal to 110 percent of the high side of the top engine speed range

Typically, high idle speed is set less than or equal to 110 percent of TEL. It is important to consider that TEL and high idle (another programmable parameter) work together to determine the overrun* portion of the power curve. The overrun portion of the power curve will change as TEL and high idle are modified. The slope of the overrun curve will be determined by the difference between TEL and high idle. Refer to the Engine Governing section for more information on engine operation between TEL and high idle speed.

* Some other common terms for overrun are "run out" or "governor curve."

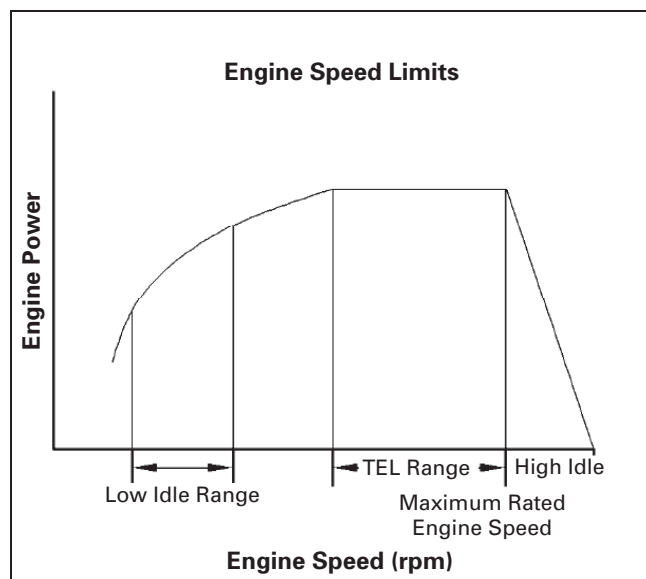

11.10.2 High Idle Speed Configuration

If the customer wants the engine's high idle speed to be 10 percent greater than the high side of the top engine speed range, then no configuration is necessary. High idle speed will always default to be 10 percent greater than the high side of the top engine speed range.

One parameter must be configured in Cat ET in order to program high idle speed.

High idle speed must be programmed to meet two criteria:

- Equal to or greater than TEL
- Less than or equal to 110 percent of the high side of the top engine speed range

11.10.3 High Idle Speed Installation

No installation is necessary.

11.11 Engine Acceleration Rate

11.11.1 Engine Accel. Rate Operation

Engine Accel. Rate is a programmable parameter. It allows the customer to program the acceleration and deceleration rate during PTO and intermediate speed operations. See PTO Ramp Up/Ramp Down, PTO Set/Resume, and Intermediate Engine Speed for further information.

NOTE: *Engine accel. rate has no effect on engine acceleration when using a PWM throttle position sensor.*

11.11.2 Engine Accel. Rate Configuration

Refer to PTO Modes and Intermediate Engine Speed configuration.

11.11.3 Engine Acceleration Rate Installation

No installation is necessary.

11.12 Throttle Arbitration Strategy

11.12.1 Throttle Arbitration Strategy Operation

If more than one speed input device or method is used, then the engine ECU chooses or “arbitrates” between the different input devices.

Strategy summary:

- Different priority signals are present: The engine ECU compares multiple speed input signals and identifies the signal with the highest priority. The highest priority speed input signal is always the signal on which the engine ECU acts.
- Same priority signals are present: If two input signals have the same priority (e.g., PTO and TPS), then the ECU selects the preferred signal based on the arbitration strategy. “Max wins” means the greater (higher rpm) speed input signal is the signal selected by the ECU.

For example: If an engine receives two speed input signals, one from a PTO and one from a TPS, and if the TPS commands a speed above the set PTO speed, the engine responds to the TPS signal.

The strategy for choosing the correct speed input device is also summarized in the table below.

INDUSTRIAL ENGINE THROTTLE ARBITRATION STRATEGY		
Desired Engine Speed Input Method	Priority	Arbitration
ET Override (dyno test mode)	1	-
Intermediate Engine Speed Switch	2	-
SAE J1939 TSC1 (Mode 1)	3	-
PTO (Power Take-Off)	4	Max wins
TPS (Throttle Position Sensor)	4	Max wins

11.12.2 Throttle Arbitration Strategy Configuration

The programmable parameter Desired Speed Input Configuration is no longer necessary. Throttle arbitration strategy eliminated the need for Desired Speed Input Configuration.

11.12.3 Throttle Arbitration Strategy Installation

Throttle arbitration strategy is set within the industrial software and cannot be altered.

12 Torque Limiting

12.1 Torque Limit Switch

12.1.1 Torque Limit Switch Operation

The torque limit switch can be used to limit engine torque output. When the torque limit switch is closed to ground, then the ECU will limit torque to the programmed value. It is important to note that when the torque limit switch is closed to ground, the torque curve is not shifted down. Rather, the torque curve is truncated or chopped at the torque limit value. Essentially, a flat spot is created in the torque curve.

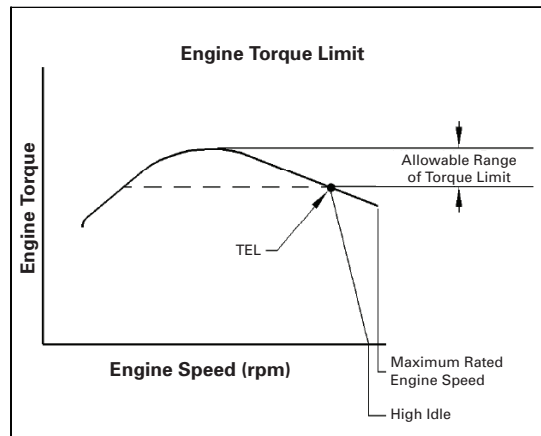

12.1.2 Torque Limit Switch Configuration

One parameter must be configured in Cat ET prior to using torque limit switch. This parameter is Maximum Engine Torque Limit. Maximum engine torque limit default varies with each flash file. This parameter cannot be programmed to less than the torque available at the programmed TEL.

12.1.3 Torque Limit Switch Installation

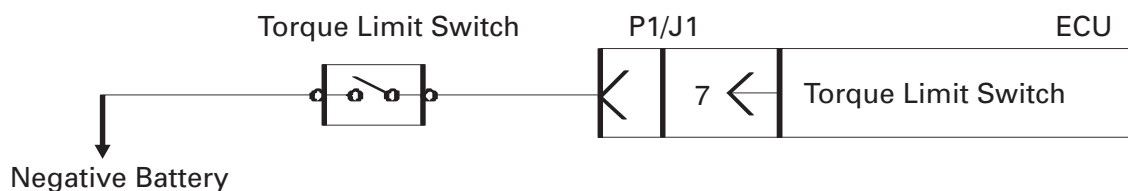

REQUIRED PARTS		
Part Number	Description	Qty
N/A	Toggle Switch (SPST, Momentary)	1
or N/A	or Toggle Switch (SPST)	
9X-3402	Connector Socket	1
N/A	Terminal	2
N/A	18 AWG Wire	(1)

⁽¹⁾ Fabricated to length

13 Engine Governor

An engine governor controls the fuel supply to the engine to control the speed and response of the engine under varying load and throttle conditions. The engine control system has the capability of being configured to utilize either a Full Range Engine Speed Governor or a Min/Max Engine Speed Governor. A Full Range Engine Speed Governor is what has traditionally been utilized on Cat industrial engines.

The terminology below will be used in the following sections to define the operation of the two governor types:

Maximum No-Load Speed or High Idle — The highest engine speed obtainable when the throttle is at the maximum position with no load applied to the engine.

Maximum Full-Load Speed or Rated Speed — The engine speed at which an engine produces maximum power.

Idle or Low Idle — The engine speed setting when the throttle is at the minimum position.

Speed Droop — Represents the increase in engine speed above the rated power setting as the full load is reduced to zero power without adjustments to the governor [i.e. difference between the no-load (high idle) speed setting and the full-load (rated) speed setting]. This is normally expressed as a percentage of rated speed.

Isochronous (Zero Droop) — Where the full-load (rated) and no-load (high idle) speeds are the same.

The governor has a number of operating limits that are referred to frequently in the following sections. Refer to Table 1 for a list of acronyms of commonly used terms. The typical value and range are representative of most software flash file configuration ranges. For exact values refer to the documentation for the flash file in TMI. Refer to the Engine Speed Demand section for more information on Idle and TEL configuration.

Table 1: Governor Parameter Acronym Definitions

Acronym	Parameter Name	Typical Value/Range
RSUL	Rated Speed Upper Limit	2100 rpm
RSLI	Rated Speed Lower Limit	1800 rpm
HIUL	High Idle Upper Limit	2200 - 2400 rpm
HILL	High Idle Lower Limit	1800 rpm
LIUL	Low Idle Upper Limit	1400 rpm
LILL	Low Idle Lower Limit	600 rpm
TEL	Top Engine Limit	RSLI to RSUL
HI	High Idle	HILL to HIUL (but not lower than TEL)
LI	Low Idle	LILL to LIUL
HSG	High Speed Governor	—

13.1 Full Range Engine Speed Governor

13.1.1 Full Range Engine Speed Governor Operation

The Full Range Engine Speed Governor will attempt to hold a constant engine speed for a given throttle position. The Full Range Engine Speed Governor senses engine speed, and perhaps load, and meters the fuel supply to the engine such that speed tends to remain constant or to vary with the load in a predetermined manner. This governor type is recommended for use on applications with constant operating speed (i.e. pumps, compressors, hydrostatic drives, etc.) and applications with manual transmissions. The Full Range Engine Speed Governor is also known as a “variable speed” or “all speed” governor.

The Full Range Engine Speed Governor control strategy calculates the fuel quantity required to keep the actual engine speed equal to a desired engine speed. The desired engine speed is the output of the throttle arbitration strategy defined in the Engine Speed Demand section. The term “full range” is used because the desired engine speed range used by the control strategy covers the “full” engine operating speed range. The governor strategy has control parameters, commonly referred to as governor gains, which determine the response and stability of the engine. The governor gains are “tuned” by Caterpillar in a lab environment for optimum engine performance under steady state and transient operating conditions.

The Full Range Engine Speed Governor used on all industrial engines to date is an isochronous (or zero droop) speed governor. Figure 1 illustrates the isochronous speed governor operation across the engine operating speed range. The curve is bounded by the rating torque curve between LI and TEL engine speeds and the HSG limit curve above TEL engine speed. The vertical lines are engine torque output for a constant throttle position, or constant engine speed demand. Thus, for a fixed throttle position below TEL engine speed, the speed governor will hold engine speed constant until the torque output reaches the torque limit curve, then the engine speed will decrease with torque output at the limit of the rated torque curve. This is also referred to as the torque lug curve.

Isochronous speed governing above the configured TEL speed is limited by the HSG limit curve. This region of operation is often referred to as the overrun region. The HSG limit curve is always below the rated torque curve. This curve is linear where the slope of the line is determined by the configured TEL and HI engine speeds.

Figure 2 illustrates two HSG limit curves with a common HI engine speed and two different TEL engine speed settings. This illustration shows that the torque output with TEL 1 setting is limited at a lower torque than the TEL 2 setting. This also shows that speed governing is isochronous at all operating speeds in the overrun region. The different TEL settings will affect the engine response and stability under varying loads in this speed operating range.

Figure 1: Isochronous Engine Speed Governor — Torque vs. Speed Curve

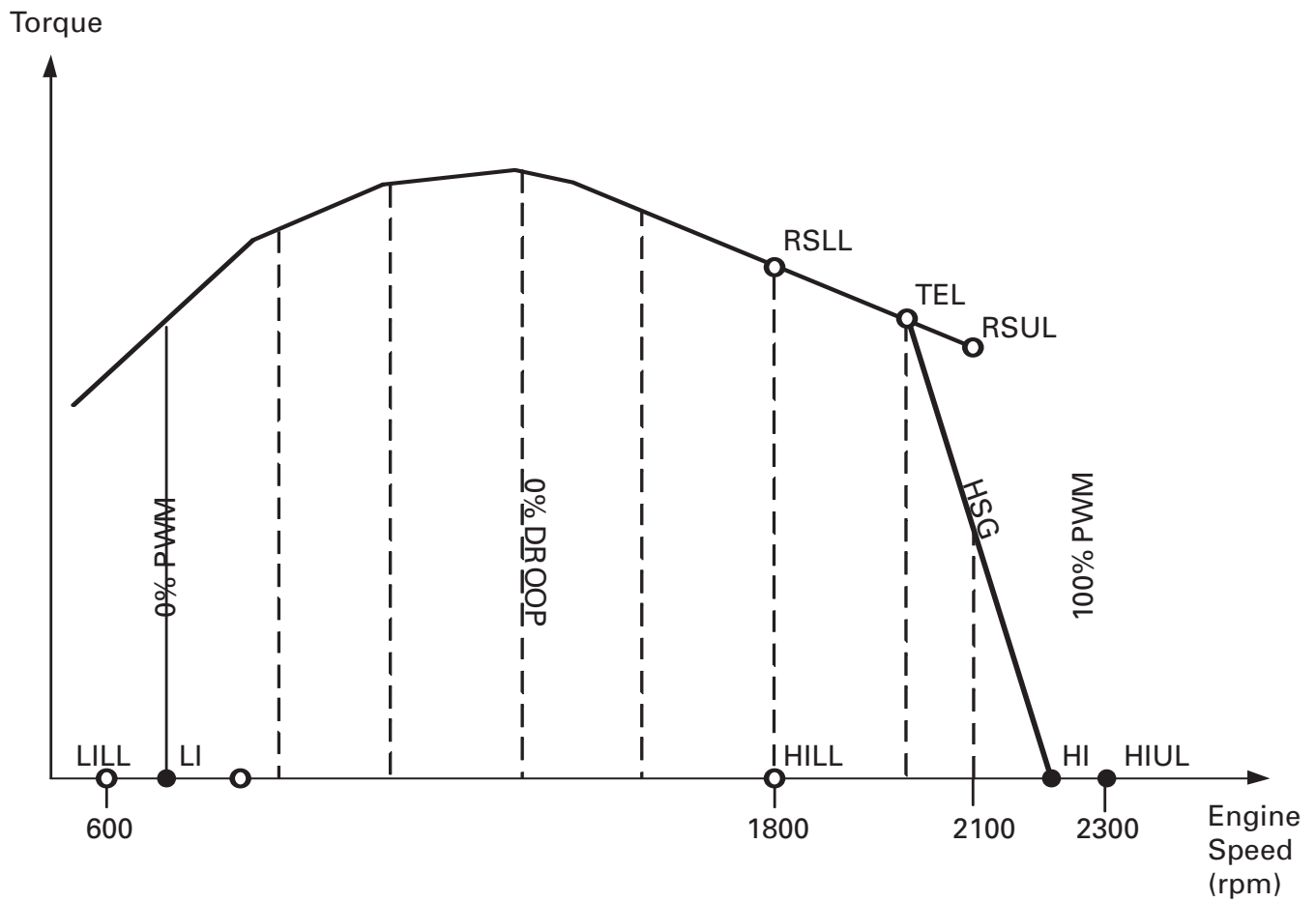
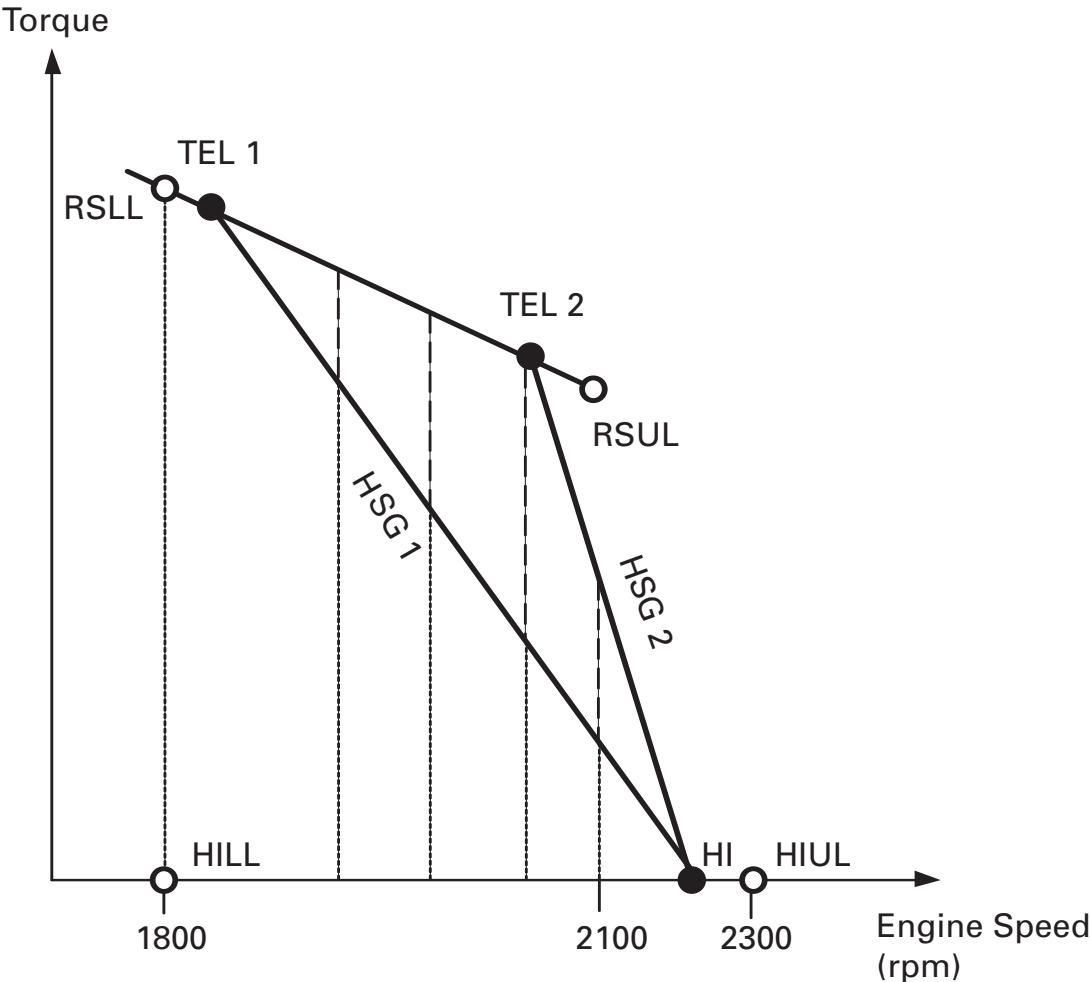

Figure 2: Isochronous Governing in Overrun Region



13.1.2 Speed Governor Configuration

No configuration is required prior to using the speed governor as the configuration parameter Engine Governor Primary Mode Configuration defaults to “Speed Control.”

13.1.3 Speed Governor Installation

The speed governor requires that one of the different methods for controlling the speed of the engine is configured. Refer to the Engine Speed Demand section for more information on configuring engine speed demand inputs.

13.2 Min/Max Governor

13.2.1 Min/Max Governor Operation

Engine Model	Rated Power (hp)	Min/Max Availability	Engine Model	Rated Power (hp)	Min/Max Availability	Engine Model	Rated Power (hp)	Min/Max Availability
C7	225	Available	C13	385	Available	C18	700	Available
C7	250	Not Available	C13	415	Available	C18	765	Not Available
C7	300	Not Available	C13	440	Available	C18	800	Not Available
C9	275	Not Available	C13	475	Available	C27	800	Available
C9	300	Not Available	C13	520	Available	C27	875	Available
C9	325	Not available	C15	440	Not Available	C27	950	Available
C9	350	Available	C15	475	Not Available	C27	1050	Available
C9	375	Not Available	C15	540	Available	C27	1150	Available
C11	325	Available	C15	580	Available	C32	950	Not Available
C11	350	Available	C15	595	Available	C32	1125	Not Available
C11	385	Available	C18	575	Available	C32	1200	Not Available
C11	420	Available	C18	600	Available	C32	1350	Not Available
C11	450	Available	C18	630	Available			

Note: This chart shows availability at the time of publication. For more current information, contact the Caterpillar Application Support Center.

The Min/Max Engine Speed Governor will provide a constant amount of power for a given throttle position. Engine speed is allowed to vary between the low idle and high idle engine speed settings. This governor essentially only “governs” engine speed when at the minimum or maximum allowed engine speed. In between these limits, the throttle position will cause the engine to produce power proportional to its value. The benefit of this type of governor is smoother shifting for engines with electronic automatic/automated transmissions. The Min/Max Governor is also known as the “limiting speed” or “power throttle” governor.

The Min/Max Engine Speed Governor control strategy uses the isochronous speed governor to control the engine speed when operating at the minimum (low idle) and maximum (high idle) speeds. This is the same control strategy used by the Full Range Engine Speed Governor, but with a fixed desired engine speed input of low idle and high idle. The governor control strategy does not try to control fuel delivery and engine speed at the operating speeds between low idle and high idle.

The Min/Max Engine Speed Governor will attempt to maintain a constant engine power output based on the throttle position. This design provides optimized shift quality with automatic transmissions and offers excellent power modulation, which allows the operator to adjust the engine power output to match typical vehicle operating conditions. The engine will accelerate or decelerate to “find” a vehicle load level that matches the engine output commanded by the throttle. If the throttle is commanding more power than the vehicle load will offer, the engine will accelerate to the high idle speed.

Machines that are lightly loaded will achieve a desired acceleration at a lower throttle position than machines that are heavily loaded. Machines with very high power/weight ratios will accelerate at very low throttle positions.

Figure 3 illustrates the Min/Max Engine Speed Governor operation across the engine operating speed range. The curve is bounded by the rating torque curve between LI and TEL engine speeds and the HSG limit curve above TEL engine speed. The horizontal lines are engine torque output for a constant throttle position. For a fixed throttle position, the Min/Max Governor will deliver a constant amount of fuel proportional to the throttle position, the torque output will remain fairly constant, and engine speed will vary with engine load.

Min/Max Governing above the configured TEL speed is limited by the HSG limit curve. This region of operation is often referred to as the overrun region. The HSG limit curve is always below the rated torque curve. This curve is linear where the slope of the line is determined by the configured TEL and HI engine speeds. Different TEL settings can affect the engine stability and performance when operating just below HI in the overrun region.

Figure 3: Min/Max Engine Speed Governor — Torque vs. Speed Curve

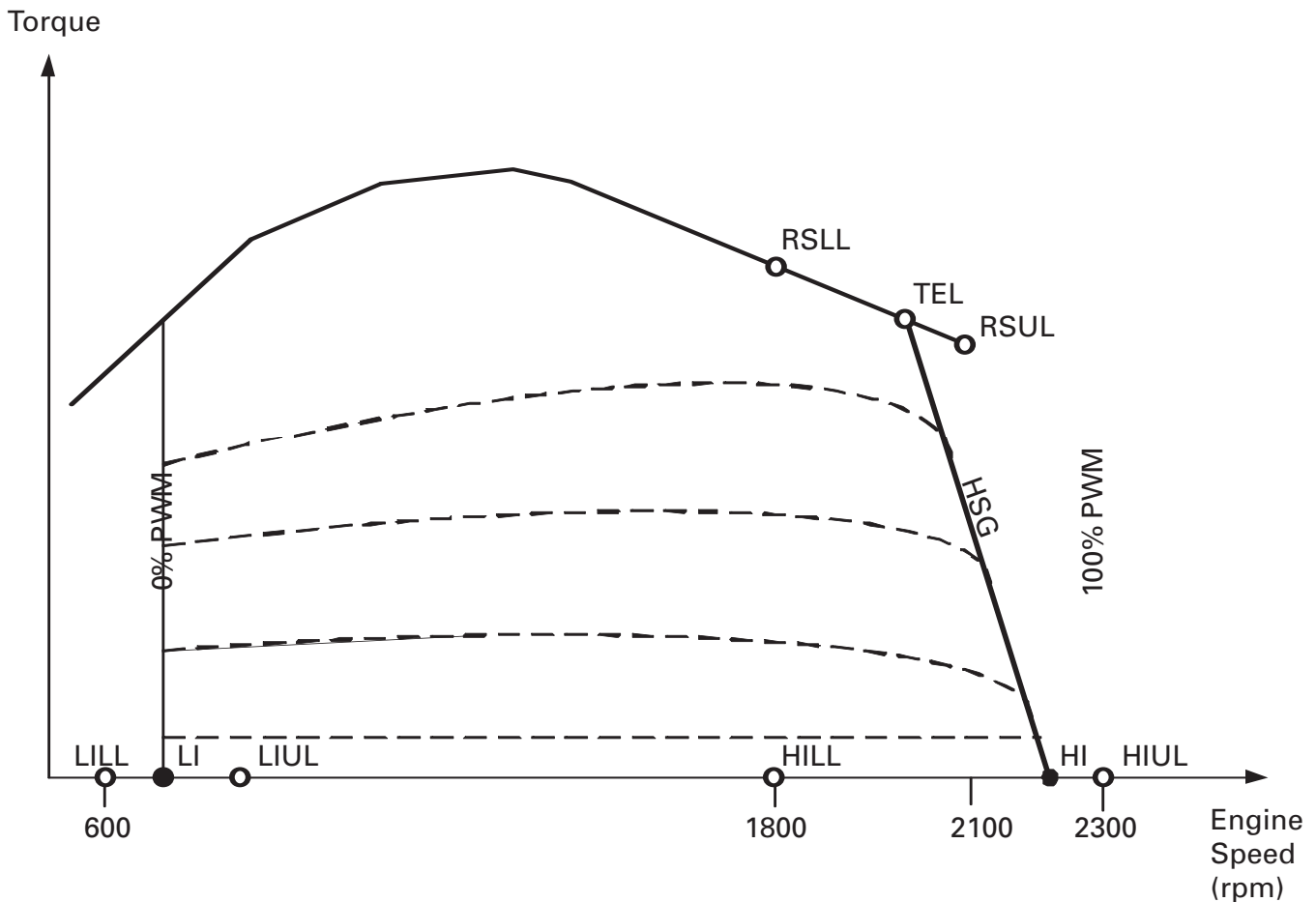

NOTE: PTO Modes, Intermediate Engine Speed, and J1939 Speed Limit Control (Ref. Section 18.1.2.1) are not functional when using the Min/Max Governor (when Engine Governing Primary Mode Configuration is set to Torque Control per Section 13.2.2). Top Engine Limit and High Idle Parameters are active when configured to Torque Control.

13.2.2 Min/Max Governor Configuration

Two parameters must be configured in Cat ET prior to using the Min/Max Governor.

1. In the configuration screen, Engine Governor Primary Mode Configuration defaults to “Speed Control” and must be set to “Torque Control.”
2. Throttle Position Sensor must be programmed to “installed.”

13.2.3 Min/Max Governor Installation

Min/Max Governor requires a Throttle Position Sensor. Refer to section on Throttle Position Sensor installation.

14 Load Calculations

14.1 Load Factor

Load Factor is the percentage of maximum possible load that the engine can produce under the current operating conditions. For example, if the load factor is 50 percent, the engine is currently loaded to 50 percent of the load that it can accept under the current operating conditions. Load factor can be viewed with Cat ET as a current measured value in the Status screen, as an average over the life of the engine in the Current Totals screen, and in 2-D and 3-D histograms over the life of the engine in the Histograms screen.

Average load factor provides a good indication of how hard an engine has worked over the engine operating life. This parameter is calculated using maximum fuel, idle fuel, and fuel used. Following is the equation used to calculate average load factor:

$$\text{Average Load Factor (\%)} = \frac{(\text{Total Actual Fuel Consumed} - \text{Total Idle Fuel Consumed})}{(\text{Maximum Possible Fuel Consumed} - \text{Maximum Possible Idle Fuel Consumed})} * 100$$

Where:

Total Actual Fuel Consumed: time integral of the fuel consumption rate (liters/hr) / 13,623

Total Idle Fuel Consumed: time integral of idle fuel rates (liters/hr) / 13,623 (idle = 550 to 1150 rpm)

Maximum Possible Fuel Consumed: time integral of rated fuel rate (liters/hr) / 13623

Maximum Possible Idle Fuel Consumed: time integral of maximum idle fuel rate (liters/hour) / 13623

NOTE: *Rated Fuel Rate takes into account: fuel temp compensation, torque limit maps, white smoke map, FARC map, turbo outlet pressure, engine speed, atmospheric pressure, and other engine operating conditions.*

14.2 Percent Load

Percent Load provides information on how hard the engine is operating compared to the maximum possible output. It is calculated using maximum fuel, idle fuel, and fuel used. The details of this calculation are shown below:

Below TEL:

$$\text{Percent Load (< TEL) (\%)} = \frac{(\text{Actual Fuel} - \text{No Load Fuel})}{(\text{Current Maximum Fuel} - \text{No Load Fuel})} * 100$$

[Current Max Fuel = Lowest Fuel From (Torque Map, Smoke Map, Cranking Map, etc.)]

TEL and Above:

$$\text{Percent Load (\geq TEL) (\%)} = \frac{(\text{Actual Fuel} - \text{No Load Fuel at High Idle})}{(\text{Maximum Fuel at TEL} - \text{No Load Fuel at High Idle})} * 100$$

15 Engine Monitoring and Protection

The engine control system provides an Engine Monitoring System to monitor critical system parameters for conditions that can damage the engine. The ECU monitors the following sensor signals:

- Auxiliary Pressure Sensor
- Auxiliary Temperature Sensor
- Coolant Level Sensor
- Fuel Pressure Sensor
- Fuel Temperature Sensor
- Engine Coolant Temperature Sensor
- Engine Oil Pressure Sensor
- Engine Speed/Timing Sensors
- Inlet Air Temperature Sensor
- Exhaust Temperature (calculated value)

The monitoring system has programmable settings that give the customer the ability to customize how the engine control system reacts to possible engine, or system, damaging conditions. The settings the customer can program determine when the control system should take action and what level of action the ECU should take in response to the harmful condition. The levels of action the ECU can be configured to take are defined as follows:

- Warning — warn operator of the critical condition
- Derate — reduce engine power to a safe operating level
- Shutdown — shutdown the engine

The level of action the ECU can be configured to take is dependent on the operating condition that is being monitored. Not all action levels are available for each condition. The customer can configure the engine monitoring system to take one, two, or all of the ECU action level options for a specific monitored condition. The ECU action level options for each of the monitored parameters are defined in the following table:

Monitoring System Parameters	Warning	Derate	Shutdown
Low engine oil pressure	•	•	•
High coolant temperature	•	•	•
Engine overspeed	•		•
High intake air temperature	•	•	
Low coolant level	•	•	•
High fuel temperature	•	•	•
High fuel pressure	•		
High auxiliary temperature	•	•	•
High auxiliary pressure	•	•	•
High exhaust temperature		•	

The timing for when the ECU takes action is based on set point and time delay settings. A set point and time delay is defined for each monitored parameter action level available for a monitored parameter. The set point is the lower (or upper) limit of a monitored parameter's normal operating range. The delay time is how long the monitored parameter must exceed the set point before the ECU will take the programmed action (warning, derate, or shutdown). Not all set points and delay times can be configured for each monitored parameter.

The action level, set point, and time delay settings are configured in the Monitoring System Configuration screen in Cat ET. The customer does not have the option to change some of the monitoring system settings for certain monitored parameters. The parameter settings that cannot be configured will default to the setting programmed in the factory. See the subsections within Engine Monitoring and Protection section for each of the monitored parameters for more information on configuring the monitoring system.

The following actions are taken by the ECU when a warning, derate, or shutdown condition is detected:

- ECU logs an event code
- Event code information is broadcast on the J1939 CAN data link
- Event code is available for display on Cat ET
- Warning lamp is turned "ON"
- Diagnostic lamp is turned "ON" (only event codes with flash codes)
- ECU performs specified derate or shutdown action

The monitoring system will reduce rated power when derate or shutdown action is specified. The rated power is reduced as a percentage from the rated power at a given engine speed. The percent derate can be a percentage drop from the rated power curve or a percent reduction towards a default power curve. When using a default curve, the default curve is typically set to 50 percent of the rated power curve. Figure 6 illustrates the power derate using a default power curve.

Figure 6: Torque Curve Derate Curve

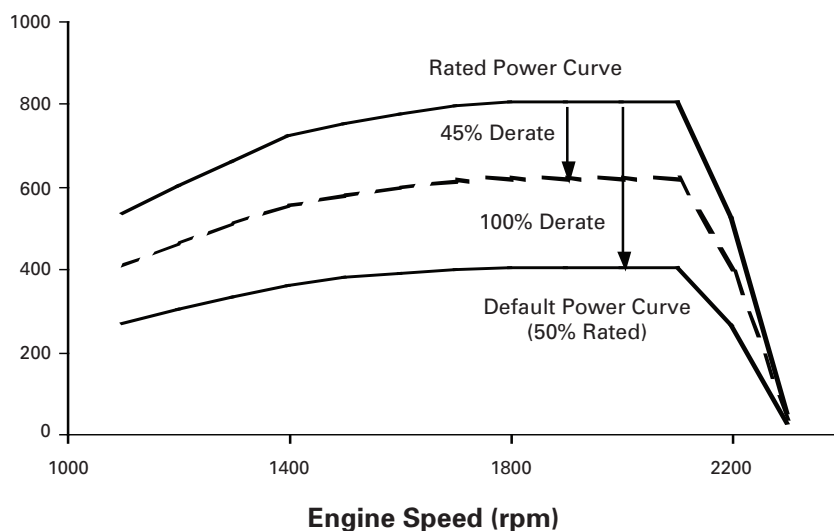

The power rating is limited in a derate condition, so this does not affect performance unless the power demand is for rated power. In other words, if you have a 10 percent derate but you are only using 10 percent of the rated power, you will have no change in operation.

15.1 Engine Monitoring Parameters

15.1.1 Oil Pressure

15.1.1.1 Oil Pressure Monitoring Operation

Engine oil pressure is monitored to automatically protect the engine from operating without sufficient oil pressure. The minimum oil pressure used for low oil pressure monitoring is defined in a graph of minimum oil pressure vs. engine speed. The graph is engine platform specific and has two different curves based on ECU response to low oil pressure condition: Warning curve and Derate/Shutdown curve (refer to graphs below).

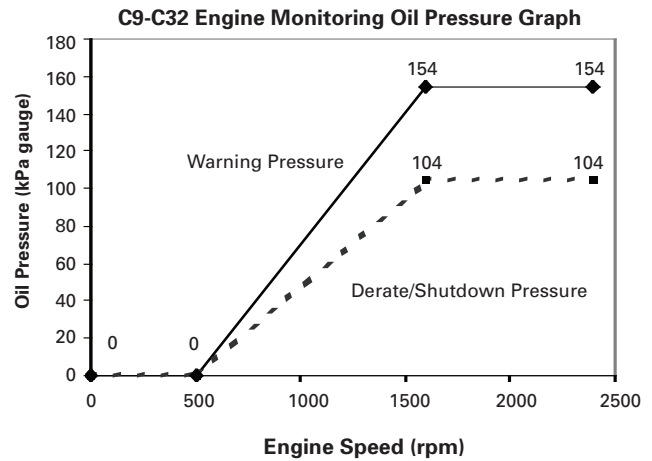
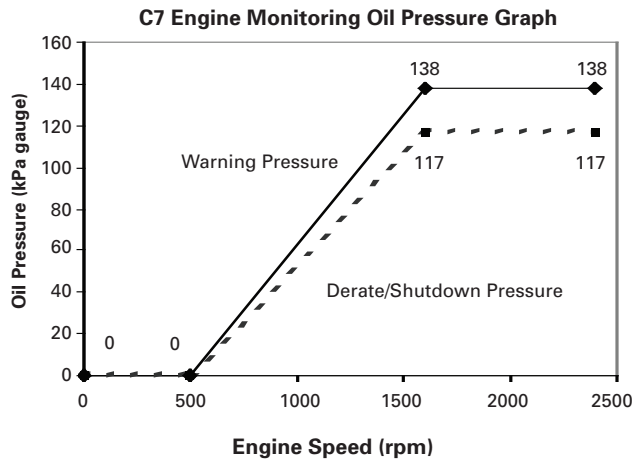

The oil pressure measured by the ECU is compared to the minimum oil pressure specified in the oil pressure graph at the current operating speed. The minimum oil pressure is checked for each ECU action level configured in the monitoring system for oil pressure monitoring. If the oil pressure is below the minimum oil pressure for the specified action level delay time, then the ECU takes the appropriate action to respond to the fault condition. Once the fault is detected, the ECU illuminates the warning and diagnostic lamps and logs the appropriate event code from the following table for the action taken:

Cat ET Description	J1939 Description	Status	SPN	FMI
Low Engine Oil Pressure	Engine Oil Pressure	Warning	100	17
		Derate	100	18
		Shutdown	100	01

The ECU can respond to the low oil pressure condition with any or all of the following actions: Warning, Derate, and Shutdown. The ECU logs an event code and illuminates the lamps for all action levels. The ECU will respond with the following additional actions when the monitoring system is configured to Derate or Shutdown:

- Derate: Engine power is reduced to 35 percent below rated power over two seconds (at a rate of 17.5 percent/second).
- Shutdown: The engine will shut down immediately.

15.1.1.2 Oil Pressure Monitoring Configuration

One parameter can be configured in Cat ET to customize the monitoring system for low oil pressure monitoring. The ECU action level is the only programmable setting for oil pressure monitoring. The ECU action level defaults to “On” for Warning and Derate and “Off” for Shutdown. All actions can be configured to “On” or “Off.”

The time delay and set point are defined by the factory and cannot be modified. The following table summarizes the configuration default settings and configuration ranges for all low engine oil pressure monitoring configuration parameters:

LOW ENGINE OIL PRESSURE MONITORING CONFIGURATION					
Action	Default Value	Time Delay (sec)		Set Points	
		Range	Default	Range	Default
Warning	On	None	8	MAP	Maps are not programmable. ⁽¹⁾
Derate	On		8		
Shutdown	Off		4		

Note: Engine has achieved low idle for 10 seconds before the above Time Delay is triggered.

⁽¹⁾ Maps are engine model specific.

15.1.1.3 Oil Pressure Monitoring Installation

No installation is required for oil pressure monitoring to function.

15.1.2 Coolant Temperature

15.1.2.1 Coolant Temperature Monitoring Operation

Coolant temperature is monitored to automatically protect the engine from exceeding the maximum engine top tank temperature limit. The coolant temperature measured by the ECU is compared to a maximum coolant temperature limit configured in the monitoring system for coolant temperature monitoring. The maximum coolant temperature is checked for each ECU action level configured in the monitoring system. If the coolant temperature is above the maximum coolant temperature for the specified action level delay time, then the ECU takes the appropriate action to respond to the fault condition. Once the fault is detected, the ECU illuminates the warning and diagnostic lamps and logs the appropriate event code from the following table for the action taken:

Cat ET MS Description	J1939 Description	Status	SPN	FMI
High Engine Coolant Temperature	Engine Coolant Temperature	Warning	110	15
		Derate	110	16
		Shutdown	110	00

The ECU can respond to the high coolant temperature condition with any or all of the following actions: Warning, Derate, and Shutdown. The ECU logs an event code and illuminates the lamps for all action levels. The ECU will respond with the following additional actions when the monitoring system is configured to Derate or Shutdown:

- Derate: Engine power is reduced according to the coolant temperature derate graph below. The power is reduced at a rate of one percent/second. The percent derate is a power reduction towards a default power curve. The 100 percent derate is typically 50 percent of the actual rated power at a given speed.

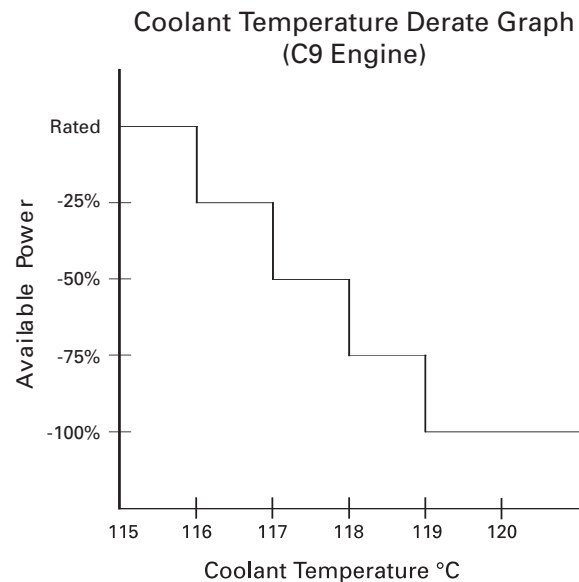
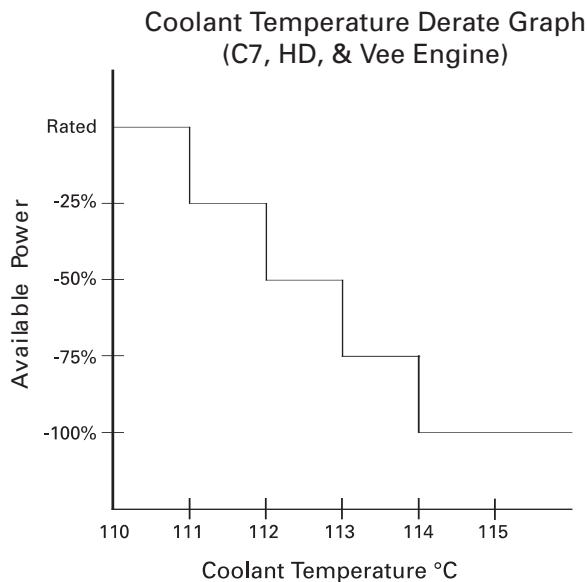

- Shutdown: The engine will shut down immediately.

15.1.2.2 Coolant Temperature Monitoring Configuration

Three parameters can be configured in Cat ET to customize the monitoring system for high coolant temperature monitoring.

1. ECU action for an event code defaults to "On" for Warning and Derate and "Off" for Shutdown. All actions can be configured to "On" or "Off."
2. Time delay to take action defaults to 10 seconds for Warning, Derate, and Shutdown. Time delay to derate or shutdown can be set between one and 120 seconds.
3. Coolant temperature maximum limits default is specific to the engine model and is defined in the configuration table on the next page. The maximum temperature limit for warning, derate, and shutdown can be lowered within the range specified in the configuration table that follows.

The following table summarizes the configuration default settings and configuration ranges for high coolant temperature monitoring:

HIGH COOLANT TEMPERATURE MONITORING CONFIGURATION					
Action	Default Value	Time Delay (sec)		Set Points	
		Range	Default	Range	Default
Warning	On	None	10	C7 85° C to 108° C C9 85° C to 113° C C11 to C32 85° C to 110° C	C7 108° C C9 113° C C11 to C32 110° C
Derate	On	1 to 120s	10	C7 86° C to 111° C C9 86° C to 116° C C11 to C32 86° C to 111° C	C7 111° C C9 116° C C11 to C32 111° C
Shutdown	Off	1 to 120s	10	C7 87° C to 111° C C9 87° C to 116° C C11 to C32 87° C to 111° C	C7 111° C C9 116° C C11 to C32 111° C

Note: Cat ET may allow the Derate Set Point Range to be programmed even though the chart above indicates that it is Not Programmable. If the set point in Cat ET is altered, this will only change the temperature at which an Event Code is logged. The programmed value will NOT change the temperatures at which the engine actually takes action in Derate.

Note: Engine has achieved low idle for 180 seconds before the above Time Delay is triggered.

15.1.2.3 Coolant Temperature Monitoring Installation

No installation is required for coolant temperature monitoring to function.

15.1.3 Engine Speed

15.1.3.1 Engine Speed Monitoring Operation

Engine speed is monitored to automatically protect the engine from exceeding the maximum engine or drivetrain speed limit. The engine speed measured by the ECU is compared to a maximum engine speed limit configured in the monitoring system for engine speed monitoring. The maximum engine speed is checked for each ECU action level configured in the monitoring system. If the engine speed is above the maximum engine speed for the specified action level delay time, then the ECU takes the appropriate action to respond to the fault condition. Once the fault is detected, the ECU illuminates the warning and diagnostic lamps and logs the appropriate event code from the following table for the action taken:

Cat ET Description	J1939 Description	Status	SPN	FMI
Engine Overspeed	Engine Speed	Warning	190	15
Engine Overspeed	Engine Speed	Shutdown	190	00

The ECU can respond to the engine overspeed condition with any or all of the following actions: Warning and Shutdown. The ECU logs an event code and illuminates the lamps for all action levels. The ECU will respond with the following additional actions when the monitoring system is configured to Shutdown:

- Shutdown: The engine will shut down immediately.

15.1.3.2 Engine Speed Monitoring Configuration

Two parameters can be configured in Cat ET to customize the monitoring system for engine overspeed monitoring.

1. ECU action for an event code defaults to "On" for Warning and Shutdown. All actions can be configured to "On" or "Off."
2. Engine speed maximum limit default is specific to the engine model and is defined in the configuration table below. The maximum speed limit for warning and shutdown can be lowered within the range specified in the configuration table below.

The time delay is defined by the factory and cannot be modified. The following table summarizes the configuration default settings and configuration ranges for engine overspeed monitoring:

ENGINE OVERSPEED MONITORING CONFIGURATION					
Action	Default Value	Time Delay (sec)		Set Points	
		Range	Default	Range	Default
Warning	On	None	1.0	C7/C9 1800 to 2600 C11-C15 1800 to 2600 C18 1800 to 2500 C27/C32 1800 to 2600	C7/C9 2600 C11-C15 2600 C18 2500 C27/C32 2600
Shutdown	On	None	1.0	C7/C9 1800 to 2800 C11-C15 1800 to 2800 C18 1800 to 2700 C27/C32 800 to 2800	C7/C9 2800 C11-C15 2800 C18 2700 C27/C32 2800

15.1.3.3 Engine Speed Monitoring Installation

No installation is required for engine speed monitoring to function.

15.1.4 Inlet Air Temperature

15.1.4.1 Inlet Air Temperature Monitoring Operation

Inlet air temperature is monitored to automatically protect the engine from exceeding a maximum inlet air temperature limit. The inlet air temperature measured by the ECU is compared to a maximum inlet air temperature limit configured in the monitoring system for inlet air temperature monitoring. The maximum inlet air temperature is checked for each ECU action level configured in the monitoring system. If the inlet air temperature is above the maximum inlet air temperature for the specified action level delay time, then the ECU takes the appropriate action to respond to the fault condition. Once the fault is detected, the ECU illuminates the warning and diagnostic lamps and logs the appropriate event code from the following table for the action taken:

Cat ET Description	J1939 Description	Status	SPN	FMI
High Inlet Air Temperature	Air Inlet Temperature	Warning	172	15
High Inlet Air Temperature	Air Inlet Temperature	Derate	172	16

Engine Monitoring and Protection

The ECU can respond to the high inlet air temperature condition with any or all of the following actions: Warning and Derate. The ECU logs an event code and illuminates the lamps for all action levels. The ECU will respond with the following additional actions when the monitoring system is configured to Derate:

- Derate: Engine power is reduced according to the inlet air temperature derate graph below. The power is reduced at a rate of one percent/second. The percent derate is a power reduction below the rated power curve.

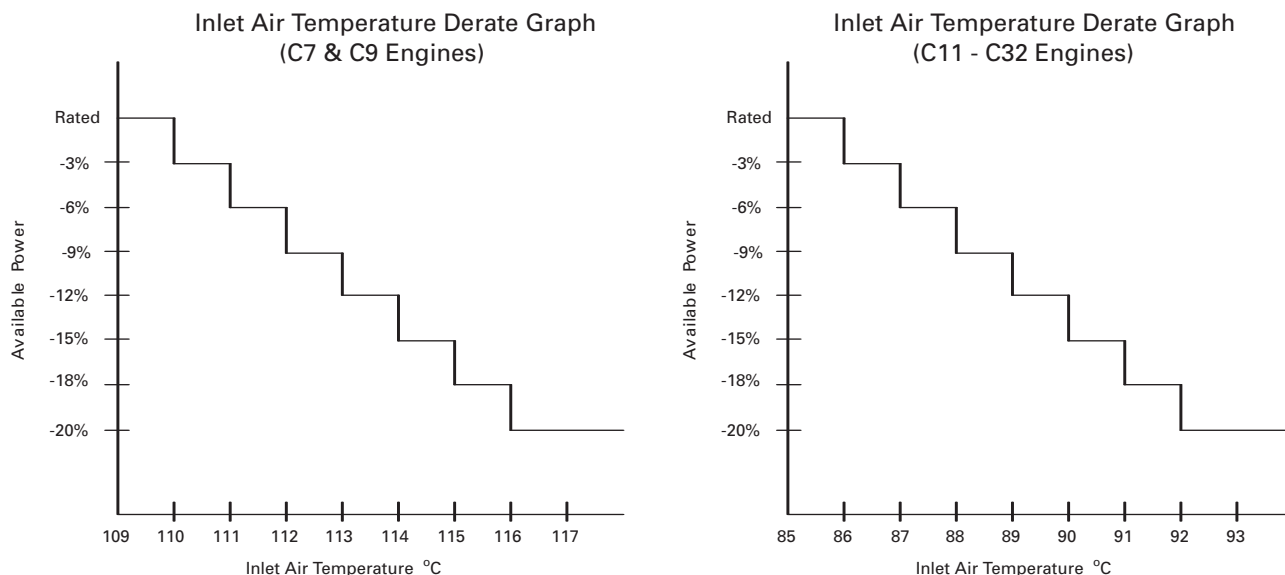

15.1.4.2 Inlet Air Temperature Monitoring Configuration

Two parameters can be configured in Cat ET to customize the monitoring system for inlet air temperature monitoring.

1. ECU action for an event code defaults to "On" for Warning and Derate. All actions can be configured to "On" or "Off."
2. Inlet air temperature maximum limit default is specific to the engine model and is defined in the configuration table below. The maximum temperature limit for warning and derate can be lowered within the range specified in the configuration table below.

The time delay is defined by the factory and cannot be modified. The following table summarizes the configuration default settings and configuration ranges for high inlet air temperature monitoring:

HIGH INLET AIR TEMPERATURE MONITORING CONFIGURATION					
Action	Default Value	Time Delay (sec)		Set Points	
		Range	Default	Range	Default
Warning	On	None	8	C7/C9 65° C to 90° C C11-C32 65° C to 82° C	C7/C9 90° C C11-C32 82° C
Derate	On	None	8	C7/C9 65° C to 110° C C11-C32 65° C to 86° C	C7/C9 110° C C11-C32 86° C

Note: Cat ET may allow the Derate Set Point Range to be programmed even though the chart above indicates that it is Not Programmable. If the set point in Cat ET is altered, this will only change the temperature at which an Event Code is logged. The programmed value will NOT change the temperatures at which the engine actually takes action in Derate.

Note: Engine has achieved low idle for 180 seconds before the above Time Delay is triggered.

15.1.4.3 Inlet Air Temperature Monitoring Installation

No installation is required for inlet air temperature monitoring to function.

15.1.5 Coolant Level

15.1.5.1 Coolant Level Monitoring Operation

The coolant level will be monitored if an optional coolant level sensor is installed. Coolant level is monitored to automatically protect the engine when the coolant level drops below a fixed level determined by the location of the sensor in the cooling system. The coolant level is checked for each ECU action level configured in the monitoring system for coolant level monitoring. If the coolant level is below the minimum coolant level specified for the specified action level delay time, then the ECU takes the appropriate action to respond to the fault condition. The engine must be running at least 60 seconds before any fault condition is triggered. Once the fault is detected, the ECU illuminates the warning and diagnostic lamps and logs the appropriate event code from the following table for the action taken:

Cat ET Description	J1939 Description	Status	SPN	FMI
Low Coolant Level	Coolant Level	Warning	111	17
		Derate	111	18
		Shutdown	111	01

The ECU can respond to the low coolant level condition with any or all of the following actions: Warning, Derate, and Shutdown. The ECU logs an event code and illuminates the lamps for all action levels. The ECU will respond with the following additional actions when the monitoring system is configured to Derate or Shutdown:

- Derate: Engine power is reduced to 35 percent below rated power over two seconds (at a rate of 17.5 percent/second).
- Shutdown: The engine will shut down immediately.

15.1.5.2 Coolant Level Monitoring Configuration

Two parameters can be configured in Cat ET to customize the monitoring system for coolant level monitoring.

1. ECU action for an event code defaults to "On" for Warning and Derate and "Off" for Shutdown. All actions can be configured to "On" or "Off."
2. Time delay to take action defaults to 10 seconds for Warning, Derate, and Shutdown. The time delay to take action on low coolant level event can be set within the range specified in the configuration table below.

NOTE: *The Time Delay for Warning, Derate, and Shutdown are triggered simultaneously. Notice in the table below, that as per Default Time Delays the engine will simultaneously begin Warning and Derate 10 seconds after the Coolant Level Switch changes state. If a customer desires a delay between Warning, Derate, and Shutdown, then the Derate and Warning Time Delay must be increased. For example, if Warning Time Delay is 10 seconds, Derate Time Delay is 20 seconds, and Shutdown Time Delay is 30 seconds. Then the warning will occur 10 seconds after the Coolant Level Switch changes state. The Derate will occur 10 seconds after the Warning begins. Finally, the Shutdown (if turned ON) will occur 10 seconds after the Derate begins.*

The set point is determined by the coolant level sensor position, thus no configuration is required. The following table summarizes the configuration default settings and configuration ranges for low coolant level monitoring:

LOW COOLANT LEVEL MONITORING CONFIGURATION					
Action	Default Value	Time Delay (sec)		Set Points	
		Range	Default	Range	Default
Warning	On	1 to 120s	10	N/A	
Derate	On	1 to 120s	10		
Shutdown	Off	1 to 120s	10		

Note: Engine has achieved low idle for 60 seconds before the above Time Delay is triggered.

15.1.5.3 Coolant Level Monitoring Installation

Coolant level sensor is an optional attachment. Refer to Coolant Level Sensor in the Customer Installed Components section of this document.

15.1.6 Fuel Temperature (C11-C18 Only)

15.1.6.1 Fuel Temperature Monitoring Operation

Only C11, C13, C15, and C18 engines have a fuel temperature sensor included in the standard sensor package. Fuel temperature is monitored to adjust fuel rate calculations and to make fuel temperature power corrections when fuel temperatures exceed 30° C (86° F) to provide constant power. Maximum power correction is achieved at 70° C (158° F). Fuel temperature above 70° C (158° F) is monitored to automatically protect the engine from exceeding a maximum fuel temperature limit. The fuel temperature measured by the ECU is compared to a maximum fuel temperature limit configured in the monitoring system for fuel temperature monitoring. The maximum fuel temperature is checked for each ECU action level configured in the monitoring system. If the fuel temperature is above maximum fuel temperature for the specified action level delay time, then the ECU takes the appropriate action to respond to the fault condition. Once the fault is detected, the ECU illuminates the warning and diagnostic lamps and logs the appropriate event code from the following table for the action taken:

Cat ET MS Description	J1939 Description	Status	SPN	FMI
High Fuel Temperature	Engine Fuel Temperature	Warning	174	15
		Derate	174	16
		Shutdown	174	00

The ECU can respond to the high fuel temperature condition with any or all of the following actions: Warning, Derate, and Shutdown. The ECU logs an event code and illuminates the lamps for all action levels. The ECU will respond with the following additional actions when the monitoring system is configured to Derate and Shutdown:

- Derate: Engine power is reduced according to the fuel temperature derate graph below. The power is reduced at a rate of one percent/second. The percent derate is a power reduction below the rated power curve.
- Shutdown: The engine will shut down immediately.

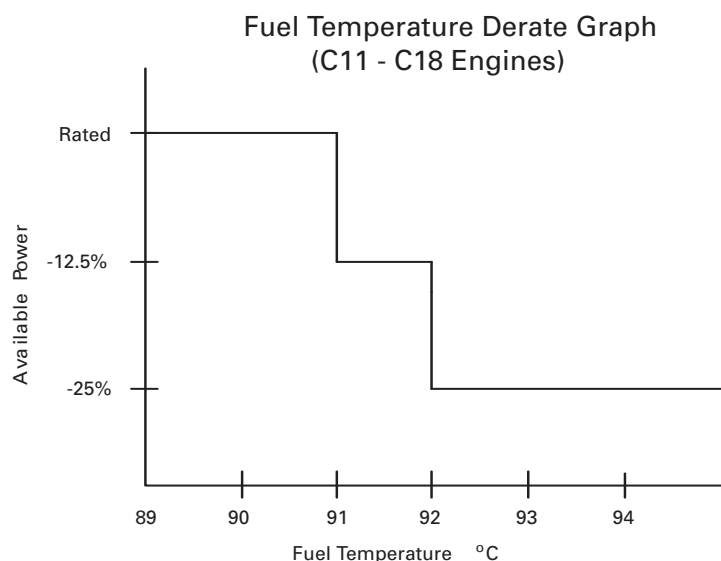

15.1.6.2 Fuel Temperature Monitoring Configuration

Three parameters can be configured in Cat ET to customize the monitoring system for fuel temperature monitoring.

1. ECU action for an event code defaults to "On" for Warning and Derate and "Off" for Shutdown. All actions can be configured to "On" or "Off."
2. Time delay to take action defaults to 30 seconds for Warning and 10 seconds for Derate and Shutdown. The time delay to take action on high fuel temperature event can be set within the range specified in the configuration table below.
3. Fuel temperature maximum limit default for Warning is 90 C° and for Derate and Shutdown is 91 C°. The maximum temperature limit can be lowered within the range specified in the configuration table below.

The following table summarizes the configuration default settings and configuration ranges for high fuel temperature monitoring:

HIGH FUEL TEMPERATURE MONITORING CONFIGURATION					
Action	Default Value	Time Delay (sec)		Set Points	
		Range	Default	Range	Default
Warning	On	1 to 120s	30	70° C to 90° C	90° C
Derate	On	1 to 120s	10	Not Programmable	91° C
Shutdown	Off	1 to 120s	10	71° C to 91° C	

NOTE: *Cat ET may allow the Derate Set Point Range to be programmed even though the chart above indicates that it is Not Programmable. If the set point in Cat ET is altered, this will only change the temperature at which an Event Code is logged. The programmed value will NOT change the temperatures at which the engine actually takes action to Derate.*

NOTE: *Engine has achieved Low Idle for 185 seconds before the above Time Delay is triggered.*

15.1.6.3 Fuel Temperature Monitoring Installation

No installation is required for fuel temperature monitoring to function.

15.1.7 Fuel Pressure

15.1.7.1 Fuel Pressure Monitoring Operation

C7-C32 engines have a fuel pressure sensor included in the standard sensor package. Fuel pressure is monitored to automatically protect the engine from exceeding a maximum fuel pressure limit. The fuel pressure measured by the ECU is compared to a maximum fuel pressure limit configured in the monitoring system for fuel pressure monitoring. If the fuel pressure is above the maximum fuel pressure for the specified warning delay time, then the ECU takes the appropriate action to respond to the fault condition. Once the fault is detected, the ECU illuminates the warning and diagnostic lamps and logs the appropriate event code from the following table for the action taken:

Cat ET Description	J1939 Description	Status	SPN	FMI
High Fuel Pressure	Fuel Delivery Pressure	Warning	94	15

15.1.7.2 Fuel Pressure Monitoring Configuration

One parameter can be configured in Cat ET to customize the monitoring system for high fuel temperature monitoring. The ECU action level is the only programmable setting for fuel temperature monitoring. ECU warning level action defaults to “On” and can be configured to “On” or “Off.”

The time delay and set point are defined by the factory and cannot be modified. The following table summarizes the configuration default settings and configuration ranges for all high fuel pressure monitoring configuration parameters:

HIGH FUEL PRESSURE MONITORING CONFIGURATION					
Action	Default Value	Time Delay (sec)		Set Points	
		Range	Default	Range	Default
Warning	On	None	8	758 kPa (gauge)	

NOTE: Engine has achieved Low Idle for 60 seconds before the above Time Delay is triggered.

15.1.7.3 Fuel Pressure Monitoring Installation

No installation is required for fuel pressure monitoring to function.

15.1.8 Auxiliary Temperature

15.1.8.1 Auxiliary Temperature Monitoring Operation

Auxiliary temperature is monitored to automatically protect a customer-defined system from exceeding the maximum temperature limit of that system. The auxiliary temperature measured by the ECU is compared to a maximum auxiliary temperature limit configured in the monitoring system for auxiliary temperature monitoring. The maximum auxiliary temperature is checked for each ECU action level configured in the monitoring system. If the auxiliary temperature is above the maximum auxiliary temperature for the specified action level delay time, then the ECU takes the appropriate action to respond to the fault condition. Once the fault is detected, the ECU illuminates the warning and diagnostic lamps and logs the appropriate event code from the following table for the action taken:

Cat ET Description	J1939 Description	Status	SPN	FMI
High Auxiliary Temperature	Auxiliary Temperature #1	Warning	441	15
		Derate	441	16
		Shutdown	441	00

The ECU can respond to the high auxiliary temperature condition with any or all of the following actions: Warning, Derate, and Shutdown. The ECU logs an event code and illuminates the lamps for all action levels. The ECU will respond with the following additional actions when the monitoring system is configured to Derate and Shutdown:

- Derate: Engine power is reduced to 25 percent below rated power over 25 seconds (at a rate of one percent/second).
- Shutdown: The engine will shut down immediately.

15.1.8.2 Auxiliary Temperature Monitoring Configuration

Three parameters can be configured in Cat ET to customize the monitoring system for high auxiliary temperature monitoring.

1. ECU action for an event code defaults to “On” for Warning and “Off” for Derate and Shutdown. All actions can be configured to “On” or “Off.”
2. Time delay to take action defaults to four seconds for Warning, Derate, and Shutdown. Time delay to take action can be set between one and 120 seconds.
3. Auxiliary temperature maximum limit default for Warning is 105° C, Derate is 106° C, and Shutdown is 107° C. The maximum temperature limit for each action can be set within the range of 0° C and 140° C.

The following table summarizes the configuration default settings and configuration ranges for high auxiliary temperature monitoring:

HIGH AUXILIARY TEMPERATURE MONITORING CONFIGURATION					
Action	Default Value	Time Delay (sec)		Set Points	
		Range	Default	Range	Default
Warning	On	1 to 120s	4	0° C to 140° C	105° C
Derate	Off	1 to 120s	4		106° C
Shutdown	Off	1 to 120s	4		107° C

NOTE: Engine has achieved Low Idle for 180 seconds before the above Time Delay is triggered.

15.1.8.3 Auxiliary Temperature Monitoring Installation

Auxiliary temperature sensor is an optional attachment. Refer to Auxiliary Temperature Sensor in the Customer Installed Components section of this document.

15.1.9 Auxiliary Pressure

15.1.9.1 Auxiliary Pressure Monitoring Operation

Auxiliary pressure is monitored to automatically protect a customer-defined system from exceeding the maximum pressure limit of that system. The auxiliary pressure measured by the ECU is compared to a maximum auxiliary pressure limit configured in the monitoring system for auxiliary pressure monitoring. The maximum auxiliary pressure is checked for each ECU action level configured in the monitoring system. If the auxiliary pressure is above the maximum auxiliary pressure for the specified action level delay time, then the ECU takes the appropriate action to respond to the fault condition. Once the fault is detected, the ECU illuminates the warning and diagnostic lamps and logs the appropriate event code from the following table for the action taken:

Cat ET Description	J1939 Description	Status	SPN	FMI
High Auxiliary Pressure	Auxiliary Pressure #1	Warning	1387	15
		Derate	1387	16
		Shutdown	1387	00

The ECU can respond to the high auxiliary pressure condition with any or all of the following actions: Warning, Derate, and Shutdown. The ECU logs an event code and illuminates the lamps for all action levels. The ECU will respond with the following additional actions when the monitoring system is configured to Derate and Shutdown:

- Derate: Engine power is reduced to 25 percent below rated power over 25 seconds (at a rate of one percent/second).
- Shutdown: The engine will shut down immediately.

15.1.9.2 Auxiliary Pressure Monitoring Configuration

Three parameters can be configured in Cat ET to customize the monitoring system for high auxiliary pressure monitoring.

1. ECU action for an event code defaults to “On” for Warning and “Off” for Derate and Shutdown. All actions can be configured to “On” or “Off.”
2. Time delay to take action defaults to four seconds for Warning and three seconds for Derate and Shutdown. Time delay to take action can be set between one and 120 seconds.
3. Auxiliary pressure maximum limit default for all events is 1500 kPa. The maximum pressure limit for each action can be set within the range of 0 kPa and 3150 kPa.

The following table summarizes the configuration default settings and configuration ranges for high auxiliary pressure monitoring:

HIGH AUXILIARY PRESSURE MONITORING CONFIGURATION					
Action	Default Value	Time Delay (sec)		Set Points	
		Range	Default	Range	Default
Warning	On	1 to 120s	4	0 kPa to 3150 kPa	1500 kPa
Derate	Off	1 to 120s	3		
Shutdown	Off	1 to 120s	3		

NOTE: Engine has achieved Low Idle for 180 seconds before the above Time Delay is triggered.

15.1.9.3 Auxiliary Pressure Monitoring Installation

Auxiliary pressure sensor is an optional attachment. Refer to Auxiliary Pressure Sensor in the Customer-Installed Components section of this document.

15.1.10 Altitude (Exhaust Temperature)

15.1.10.1 Altitude (Exhaust Temperature) Monitoring Operation

Engine operation at higher altitudes can reduce engine performance because of limited air intake by the engine. When air intake is limited, the fuel delivered to the engine needs to be reduced to minimize engine exhaust temperatures and thermal wear on the exhaust system and turbochargers. Engines with the ADEM A4 ECU have a new altitude derate strategy that reduces fuel quantity delivered to the engine based on a calculated percent exhaust temperature derate. The old altitude derate strategy was based on a calculated percent altitude derate.

The old altitude derate strategy only used the measured atmospheric (barometric) pressure to calculate a percent altitude derate. The new altitude derate strategy uses a calculated exhaust temperature to calculate a percent exhaust temperature derate. The exhaust temperature is calculated using measured atmospheric pressure, inlet air temperature, and engine speed.

The exhaust temperature derate calculation is specific to the engine family, arrangement, and rating. Refer to the published engine performance data for the specific engine rating to determine altitude capability and percent derate at altitude. If the exhaust temperature is above the maximum exhaust temperature, then the ECU takes the appropriate action to respond to the derate condition. Once the fault is detected, the ECU broadcasts the event code in the following table:

Cat ET Description	J1939 Description	Status	SPN	FMI
High Exhaust Temperature	Exhaust Gas Temperature	Derate	173	16

The ECU does not illuminate the warning or diagnostic lamp when a high exhaust temperature derate condition is detected. Cat ET will display “Exhaust Temperature Derate Active” in the status flag area on the status screen.

NOTE: *There is NOT an exhaust temperature sensor on the engine.*

NOTE: *Underground applications and high altitude applications present special application design challenges. Before designing an industrial engine into a machine chassis, consult your dealer and the industrial engine application and installation engineer.*

15.1.10.2 Altitude (Exhaust Temperature) Monitoring Configuration

No configuration is required for the altitude derate protection to function.

15.1.10.3 Altitude (Exhaust Temperature) Monitoring Installation

No installation is required to implement altitude derate protection.

15.2 Engine Monitoring Lamps

15.2.1 Warning Lamp

15.2.1.1 Warning Lamp Operation

The warning lamp is used to alert the operator of an engine operating condition that has the potential to cause engine damage. This warning lamp relates to Section 15 — Engine Monitoring and Protection. Parameters from Section 15 with Warning set to ON will activate this lamp. Installation of a warning lamp is required. An alternative display product can be used instead of a lamp as long as the display alerts the operator of the engine operation condition.

The lamp will illuminate when the ECU detects engine operating parameters exceeding a specified limit. The ECU identifies the operating condition with an event code. The lamp will remain ON as long as the engine operating condition exceeds the specified limit. The illuminated lamp will be solid or flash, depending on the event type and severity. The diagnostic lamp turns OFF when the engine returns to normal operation.

Upon ECU power-up, a self-test of lamp circuits occurs. The lamps will come ON for five seconds when the ECU is first turned on in order to indicate that the lamp circuit is functional.

15.2.1.2 Warning Lamp Configuration

No configuration is required for operation of the warning lamp.

15.2.1.3 Warning Lamp Installation

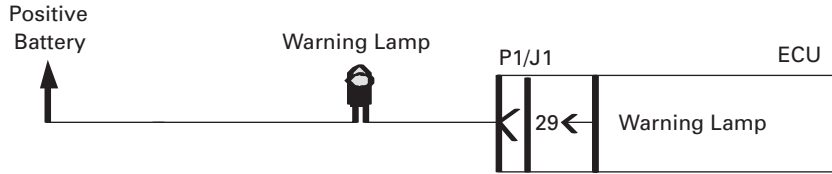

REQUIRED PARTS		
Part Number	Description	Qty
9X-3402	Connector Socket	1
N/A	Lamp	1
N/A	18 AWG Wire (ECU)	(1)

⁽¹⁾ Cut to length

15.2.2 Diagnostic Lamp

15.2.2.1 Diagnostic Lamp Operation

The diagnostic lamp is used to alert the operator of an engine electronic system malfunction. Installation of a diagnostic lamp is required. An alternative display product can be used instead of a lamp as long as the display alerts the operator of the fault status.

The lamp will illuminate when the ECU detects a component operating outside of specified normal operating range. The ECU identifies the failed component with a diagnostic code. The lamp will remain ON as long as the diagnostic code remains active. The diagnostic lamp turns OFF when the suspect component returns to normal operation and the ECU determines the diagnostic code is no longer active.

The diagnostic lamp will flash (cycle ON, then OFF) in a defined sequence to a Caterpillar proprietary two-digit flash code. The sequence of flashes represents the system diagnostic message (flash code). The first sequence of flashes represents the first digit of the flash code. After a two-second pause, a second sequence of flashes, which represents the second digit of the flash code, will occur. Any additional flash codes will follow after a pause. These flash codes will be displayed in the same manner. Flash codes should only be used to indicate the nature of a diagnostic condition. Do not use flash codes to perform detailed troubleshooting. Refer to the Troubleshooting Guide for the engine for more detailed information on diagnostic codes and flash codes.

Upon ECU power-up, a self-test of lamp circuits occurs. The lamps will come ON for five seconds when the ECU is first turned on in order to indicate that the lamp circuit is functional.

15.2.2.2 Diagnostic Lamp Configuration

No configuration is required for operation of the diagnostic lamp.

15.2.2.3 Diagnostic Lamp Installation

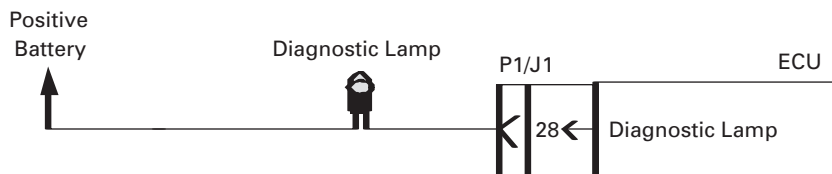

REQUIRED PARTS		
Part Number	Description	Qty
9X-3402	Connector Socket	1
N/A	Lamp	1
N/A	18 AWG Wire (ECU)	(1)

⁽¹⁾ Cut to length

15.3 Engine Monitoring System Tests

15.3.1 Engine Overspeed Verify Switch

15.3.1.1 Overspeed Verify Switch Operation

The overspeed verify switch is provided so that a service technician can test the air shutoff system. The purpose of the overspeed verify switch is to allow the service technician to validate the overspeed protection system on the engine without actually overspeeding the engine. Once the switch is closed to ground, the overspeed protection will be activated at 75 percent of the programmed overspeed value. This overspeed protection may be either disabling fuel injection or activating an air shutoff, depending upon the customer's installation.

If the overspeed verify function is enabled, the warning lamp will turn on and the air shutoffs will close and injection will be disabled when the engine reaches 75 percent of the overspeed warning trip level set in the Programmable Monitoring System.

Once the air shutoff solenoid has been activated, the ECU must be power cycled (key switch off, then on), and the air shutoff doors must be manually reset to re-start the engine. The airshut off doors will remain closed until ECU power has been cycled and the doors have been manually reset.

15.3.1.2 Overspeed Verify Switch Configuration

No configuration is required for the overspeed verify switch to function.

15.3.1.3 Overspeed Verify Switch Installation

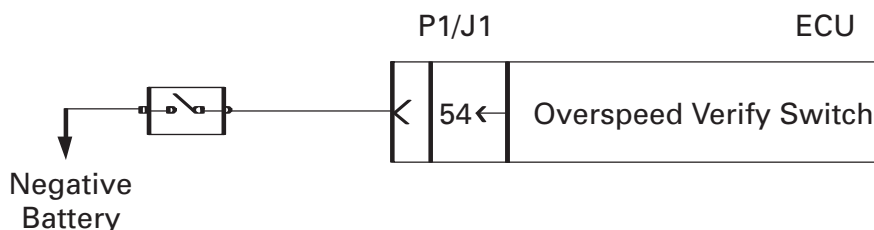

REQUIRED PARTS		
Part Number	Description	Qty
9X-3402	Connector Socket	1
N/A	Switch	1
N/A	18 AWG Wire (ECU)	(1)

⁽¹⁾ Cut to length

15.4 Engine Maintenance Indicator

15.4.1 Maintenance Indicator Operation

The ECU records data that is related to equipment maintenance. The ECU will activate the maintenance indicator lamp when scheduled maintenance is due. The maintenance indicator lamp is reset when the maintenance clear switch is closed to ground. The maintenance interval can be based on operating hours or on fuel consumption. The ECU provides information that pertains to maintenance intervals and the last maintenance that was performed.

15.4.2 Maintenance Indicator Mode Configuration

Two parameters must be configured in Cat ET prior to using the maintenance lamp and maintenance clear switch.

1. "Maintenance Indicator Mode" defaults to OFF; it can be set to:
 - a. OFF
 - b. Auto Fuel
 - c. Auto Hour
 - d. Man Fuel
 - e. Man Hour
2. "PM1 Interval" defaults to 250 hours; it can be set to:
 - a. 100 to 750 hours
 - b. 3785 to 28390 L (1000 to 7500 US gal)

NOTE: If Maintenance Indicator Mode is set to Auto Fuel or Auto Hours, then PM1 Interval does not apply.

15.4.3 Maintenance Indicator Installation

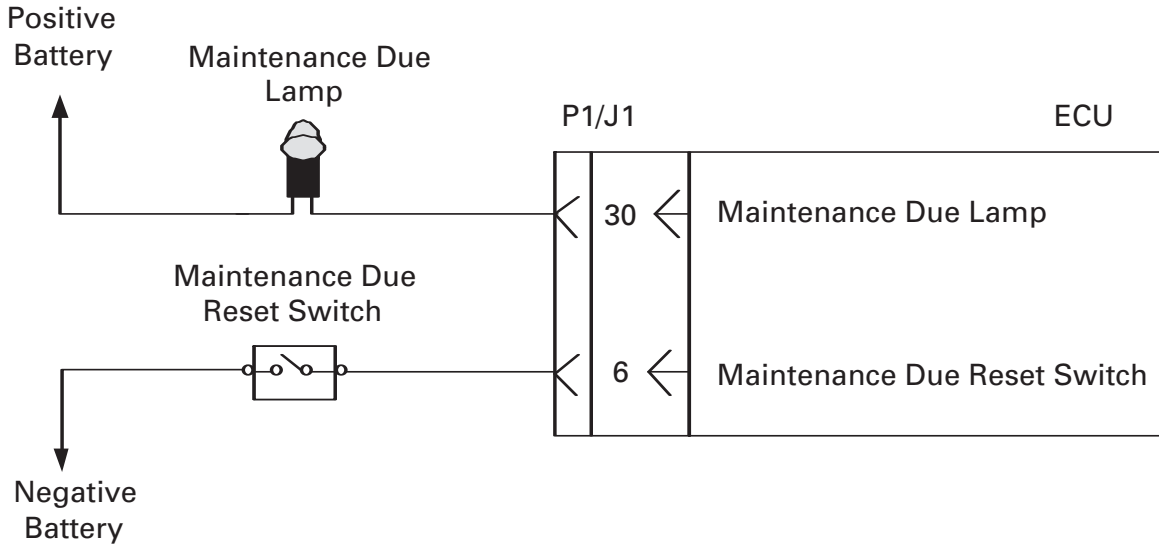

REQUIRED PARTS		
Part Number	Description	Qty
N/A	Toggle Switch (SPST, Momentary)	1
9X-3402	Connector Socket	2
N/A	Terminal	2
N/A	Lamp	1
N/A	18 AWG Wire	(1)

⁽¹⁾ Fabricated to length

16 Cold Starting Aid

Cold start strategies are developed in a laboratory environment (cold room) using worst-case machine parasitic load cases. All possible configurations and load cases cannot be developed and tested. If your particular application has very high parasitic loads, extreme cold (arctic) conditions, or unique engine load or configuration issues, please consult your application engineer prior to purchase.

16.1 Third Party Supplied Ether Injection Systems

Caterpillar strongly recommends the use of ether components supplied via the Caterpillar Industrial Engine Price List. If third party supplied systems are used, contact the Application Support Center for a review of third party supplied components. Caterpillar will review, but not approve the use of third party supplied components for ether injection systems.

16.2 Continuous Flow Ether Starting Aid System

16.2.1 Ether Start Operation

The ether solenoid control is available to drive a relay and/or solenoid to control ether delivery to the intake manifold. The ECU controls the ether solenoid control output when conditions dictate the use of a starting aid. Caterpillar offers an optional ether start system matched to each engine's particular cold start strategy. Please refer to the industrial engine price list for the appropriate parts. Caterpillar Application approval must be obtained. Contact the Application Support Center for this approval.

If there are active faults on both the coolant temperature sensor and the inlet air temperature sensor, the ECU will not activate the ether injection system. If there is an active fault on either the air temperature sensor or the coolant temperature sensor, the valid sensor will be used in the ether control strategy. If both the air temperature and coolant temperature sensor are valid, then the coldest temperature will be used. If both sensors are valid, then usage of a block heater will not affect the ether control strategy.

The ether control strategy establishes ether injection durations based on temperature and altitude. The temperature threshold is not programmable by the customer. If the temperature is below the threshold [0° C (32° F) at sea level] and an attempt is made to start the engine, the ether solenoid control will be enabled until the engine rpm reaches 50 rpm less than low idle. If the engine starts or a condition occurs that prevents fuel from being injected, the ether solenoid control will be disabled.

Ether will only be injected while engine speed is greater than zero. Ether will not be injected prior to cranking the engine.

16.2.2 Ether Start Configuration

Either of two parameters must be configured in Cat ET prior to using ether start.

1. Ether control defaults to "Disabled" and must be programmed to "Enabled."
2. Ether solenoid configuration defaults to "Not Installed" and must be programmed to "Continuous Flow Solenoid."

Which parameter to configure depends on the engine flash file and version of Cat ET.

16.2.3 Ether Start Installation

The continuous flow ether system is available as an optional attachment on the industrial engine price list. The component in the ether system that controls ether quantity and spray angle is the atomizer. The atomizer has a control orifice that is sized for a specific range of intake air flow. Be sure to order the correct ether system to match the engine.

The ECU can activate the ether control valve solenoid with a direct connection from ECU to the solenoid. Older systems required the use of a relay to switch battery supply to the solenoid, but the relay is no longer required due to more efficient solenoids and the higher current capability of the ECU driver.

NOTE: *The ECU will source 2.0 amps at normal operating conditions. At cold operating conditions, the ECU may source as low as 1.0 amp to the solenoid or relay. Caterpillar Industrial Price List components have been selected to operate in this 1.0-2.0 amp range.*

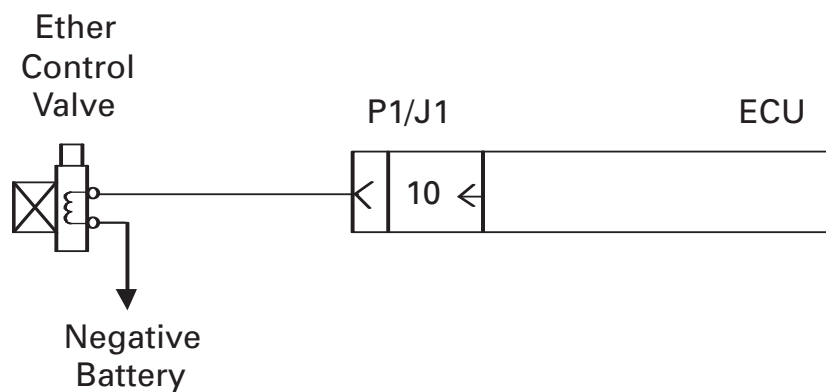

REQUIRED PARTS		
Part Number	Description	Qty
(1)	Ether Control Valve	1
(1)	Terminal	2
9X-3402	Connector Socket	1
N/A	16 AWG Wire	(2)

(1) Refer to the appropriate parts manual for your engine.

(2) Fabricated to length

16.3 Air Inlet Heater (C7 and C9 Engines Only)

16.3.1 Air Inlet Heater Operation

The Inlet Air Heater (IAH) is used to improve cold starting of the engine. The ECU controls the IAH through the inlet air heater relay. The heater and relay are installed on the engine at Caterpillar. An air inlet heater and a continuous flow ether starting aid system can be installed on the same engine. The ECU start aid strategy controls device priority so that these devices cannot operate at the same time.

The Inlet Air Heater operation is determined at five different stages: Power-Up, Preheat, Engine Cranking, Engine Running, and Post Heat. The trip point temperature for the various stages of air inlet heater operation is determined by the sum of the coolant temperature and the inlet air temperature.

NOTE: *If a block heater is used, and if the sum of coolant temperature and air temperature is greater than 64° C, then the air inlet heater will not operate.*

NOTE: *DO NOT convert the sum of the temperatures!!! The temperatures MUST be converted before summing! The ECU adds coolant temperature and inlet manifold air temperature as measured in centigrade. In order to get the correct conversion of the summed value in Fahrenheit, each temperature must first be converted to Fahrenheit and then added together as follows: $([Coolant\ Temperature\ ^\circ C] \times 1.8 + 32) + ([Inlet\ Manifold\ Air\ Temperature\ ^\circ C] \times 1.8 + 32) = \text{sum in Fahrenheit.}$*

Following is an overview of the air inlet heater operation at the five stages of a normal start:

1. Power-up cycle. The heater and wait-to-start lamps will turn ON, and then turn OFF after two seconds if the temperature conditions for preheat are not met. The power-up cycle is essentially a component check. This will happen regardless of the temperatures or engine speed.
2. Preheat cycle. If the sum of the coolant temperature and inlet manifold air temperature is less than 64° C (147° F), the ECU will turn the inlet air heater relay output and wait-to-start lamp ON for up to 30 seconds as a preheat cycle. If the operator attempts to start the engine before the preheat cycle ends, the ECU will continue to control the heater during engine cranking cycle. The wait-to-start lamp will turn OFF when engine speed is detected. The heater and lamp are turned OFF after a maximum of 30 seconds if the engine speed is still 0 rpm, regardless of the temperature.
3. Engine cranking cycle. When the engine is cranking, the heater will turn ON if the sum of the coolant temperature and inlet manifold air temperature is less than 147° F or 64° C and will stay ON while cranking. If the engine fails to start, the preheat cycle is restarted.
4. Engine running cycle. After the engine has achieved low idle speed, the IAH operation is determined by the same combination of both the inlet manifold air temperature and coolant temperature. If the temperature conditions are met, the heater may be ON for a maximum of seven minutes. The inlet air heater will turn OFF anytime the sum of the inlet manifold air temperature and coolant temperature exceeds 147° F or 64° C. If the engine stalls or stops, the preheat cycle is restarted.
5. Post-heat cycle. If after the seven-minute engine running cycle the coolant temperature and air temperature are below 147° F or 64° C, then the heater is cycled on and off for an additional 13 minutes. The cycle is 10 seconds ON and 10 seconds OFF.

If there are logged faults on both the coolant temp sensor and the inlet manifold air temperature sensor, the ECU will not activate the air inlet heater. Whenever there is an active diagnostic code for the coolant temperature sensor, the heater will activate if the inlet manifold air temperature is less than 10° C (50° F). For an active inlet manifold air temperature sensor diagnostic, the heater will activate if coolant temperature is less than 40° C (104° F).

16.3.2 Air Inlet Heater Configuration

The “Air Inlet Heater Installation Status” must be programmed to “Enabled” via Cat ET if an air inlet heater is installed. This allows the ECU to control the inlet air heater. The default on C7 and C9 engines is “Enabled.”

16.3.3 Air Inlet Heater Installation

Install the wait-to-start lamp. Refer to the wait-to-start lamp installation instructions in the “Starting and Stopping the Engine” section.

The customer is responsible for connecting the contact side of the inlet air heater relay to battery voltage. Recommended circuit protection for this connection is 130 amps with a circuit load of 100 amps continuous. The inlet air heater relay has a maximum “ON” time of seven minutes. Minimum required wire size is 4 AWG.

The battery supply wire must be secured and not attached to a fuel line. Secure the wire with the clip before applying the proper torque of 9.0 Newton-Meters (N•m) +/- 1.0 N•m to the wire terminal at the terminal stud. Wire terminal nuts and locking washers are supplied with the relay. Caterpillar recommends the use of a breaking torque wrench such as the Mountz TLS-1360.

CAUTION: *Not meeting the specified torque limit may cause electrical arcing due to a mechanical failure of the relay stud or a loose connection.*

A boot must be installed on the battery connection to the inlet air heater relay to help prevent electrical arcing. This boot must be made of heat-resistant material that can meet the UL94V0 rating for flammability. Choose terminals made of tin-plated brass with a hole size that is closest to the diameter of the stud (5/16 inch). The terminal hole should provide enough clearance to make assembly easy while maintaining contact. Caution must be taken to prevent the terminal from causing a short to chassis ground. Caterpillar recommends that the terminal ring connection to the battery supply wire be made with a bare terminal and then insulated using a sealed heat shrink.

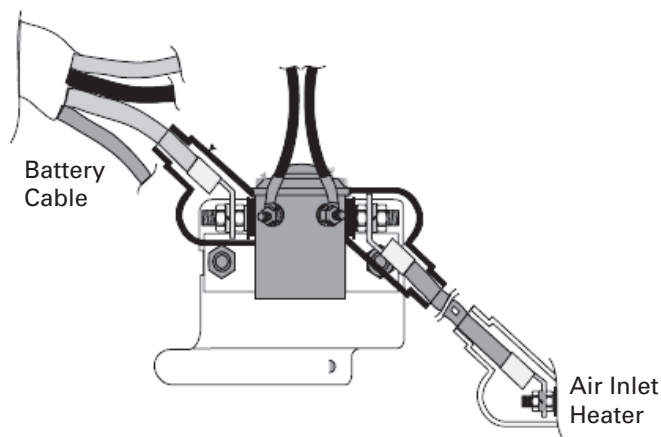

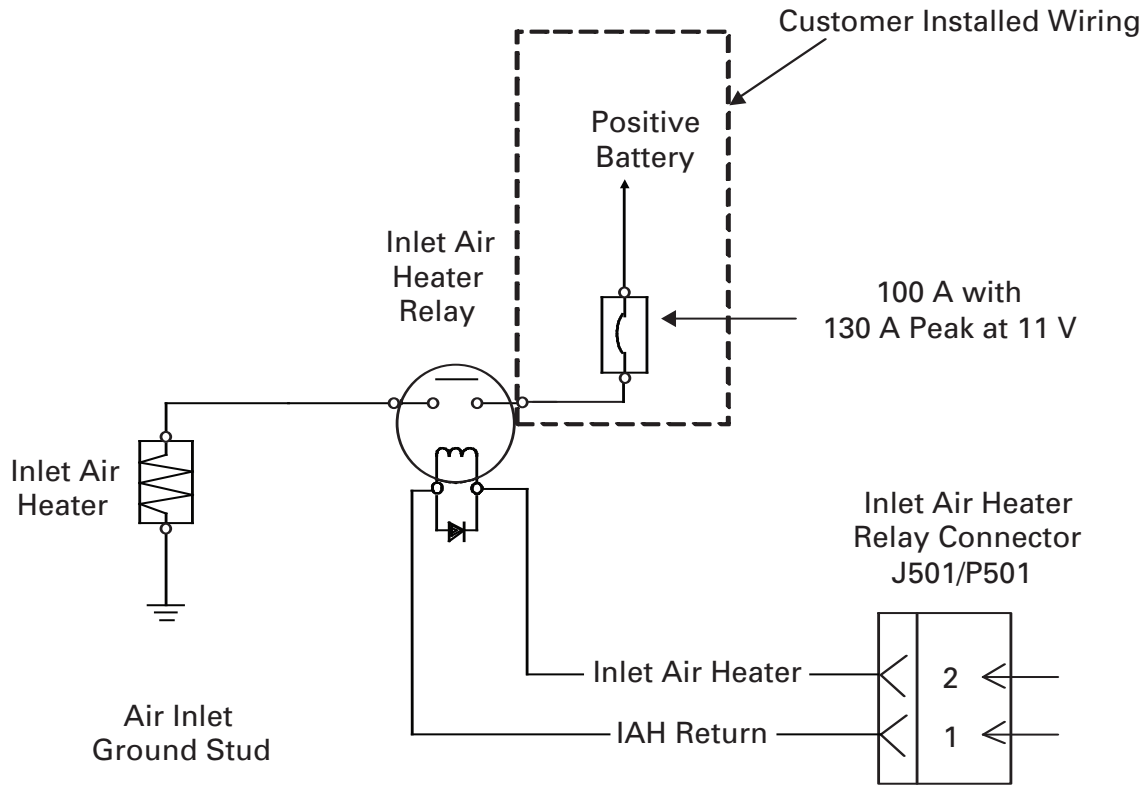

REQUIRED PARTS		
Part Number	Description	Qty
N/A	Circuit Breaker (100 amp)	1
9G-4343	Terminal	3
N/A	4 AWG wire	(1)

⁽¹⁾ Fabricated to length

16.4 Starting Aid Selection Strategy (C7 and C9 Engines Only)

If an ether injection system and an air inlet heater are both installed and configured, the ECU will automatically determine and activate the optimum device for starting. If inlet air temperature or coolant temperature is below 0° C, ether will be activated for starting. The ether will not turn on if the inlet air heater is on.

NOTE: An air inlet heater and an ether injection system can be installed on the same engine, but they will not operate at the same time.

17 Operator Display

17.1 Industrial Messenger

The industrial messenger (Cat part number 243-3820) is a digital LCD display that replaces the EMS display in the Industrial Price List. The messenger display communicates with the ECU on the J1939 data link. For more information on the industrial messenger, refer to REHS1413, "Installation and Operation of the Caterpillar Messenger Driver Information Display."

Parameters Displayed on Industrial Messenger

- Desired Engine Speed
- Engine Speed
- Oil Pressure
- Boost Pressure
- Engine Load
- Battery Voltage
- Coolant Temperature
- Fuel Pressure
- Fuel Temperature
- Fuel Rate
- Auxiliary Temperature
- Auxiliary Pressure
- Intake Temperature
- Engine Hours

Diagnostics Displayed on Industrial Messenger

- Events
- Active Diagnostic Codes
- Logged Diagnostics

18 Data Link Support

The Caterpillar industrial engines provide two data link connections on the engine ECU. OEM communication with the engine is via the CAN bus using SAE J1939 protocol. Caterpillar service tool communication with the engine is via the proprietary Caterpillar Data Link (CDL). Caterpillar recognizes that other CAN bus standards (higher level protocols) do exist and are used in off-highway applications, so the following sections provide some information for users of those standards.

18.1 SAE J1939

The SAE J1939 standard was initially developed for the U.S. truck and bus industry. It has been expanded and is now the most widely used data link standard for industrial powertrains, with compliance from almost all engine manufacturers and most transmission manufacturers.

18.1.1 Summary of Key J1939 Application Issues

This is a summary of key points and answers to frequently asked questions relating to design of a J1939 compatible network. It is intended to give a design overview and does not in any way replace or contradict the recommendations contained in the SAE J1939 standard documents.

18.1.1.1 Physical Layer

- The data rate is 250 KBits/sec.
- Twisted-pair cable, of a 120-Ohm impedance characteristic, should be used throughout. Note that most commercially available twisted-pair cable is not suitable.
- It is recommended that this cable is shielded (as per J1939-11) and that the screen is grounded at a central point in the network. Some machine manufacturers use unshielded twisted-pair cable (as per J1939-15), offering lower cost but lower immunity to electromagnetic noise.
- The bus is linear and should be terminated with 120-Ohm resistors at either end. It is a common mistake to use one 60-Ohm resistor instead of two 120-Ohm resistors. This does not work correctly, however.
- Maximum bus length is 40 m.
- The terminating resistors should not be contained in network nodes.
- Network nodes are connected to the bus via stubs of the maximum recommended length of one meter.

18.1.1.2 Network Layer

- J1939 recommends a bit sample point of 87 percent. This relatively late sample point gives best compromise for immunity to noise and propagation delay. This does restrict the size of the software jump width (SJW).
- All nodes should have the same bit timing.
- Accurate bit timing is essential (4°s +/- 0.2 percent).
- It is recommended that the average bus load not be greater than 40 percent.

- Hardware filtering (masking) of CAN messages should be used under high bus loads to limit demands on processors.
- The engine ECU always assumes a fixed address of 0. It will not change its address in the arbitration process described in J1939-81.
- The transport protocol (described in J1939-21) is used for sending messages with more than eight bytes of data. In the industrial engine application this will be used principally for the diagnostic messages DM1 and DM2.
- Information may be broadcast, at regular intervals, or requested. For example, the engine will broadcast its “current speed” every 20 ms, but it will only send “hours run” information if another node requests it.

18.1.1.3 Application Layer

- Data link messages are used by devices on the CAN bus for monitoring and display of engine information or as control interface between integrated control modules.
- Messages on the J1939 data link are sent in packets of logically grouped system information. These packets, or data link strings, are referenced by the Parameter Group Number (PGN) that is assigned to each message by the SAE standard.
- The PGNs supported by the Caterpillar Industrial ECU are only a subset of the messages described in J1939-71 and J1939-73.
- Some PGNs may be partially supported, i.e. only those bytes for which the ECU has valid data will be supported.
- Unsupported data bytes are generally sent as FF (hex), and incorrect or invalid information is sent as FE.

18.1.2 Supported Parameters — Section 71: Engine System Parameters

This section defines the engine control system support and implementation of parameter groups defined in the vehicle application layer of the SAE J1939 standard (J1939-71).

These parameter groups are used by devices on the CAN bus for engine control and monitoring and display of engine performance and status information.

The message identifier, update rate, and parameter group definition is specified for each supported parameter group. Any deviation from the SAE recommended practice is noted below each parameter group table.

The industrial engine control system supports the parameter group numbers (PGN) listed in the following table:

Parameter Group	PGN		SPN	Parameters Supported
	Dec	Hex		
Torque/Speed Control 1 (TSC1)	0	0000	695	Engine Override Control Mode
			898	Engine Requested Speed/Speed Limit
Electronic Transmission Controller 1 (ETC1)	61442	F002	191	Transmission Output Shaft Speed
Electronic Engine Control 2 (EEC2)	61443	F003	91	Accelerator Pedal Position 1
			92	Engine Percent Load at Current Speed
Electronic Engine Control 1 (EEC1)	61444	F004	513	Actual Engine — Percent Torque
			190	Engine Speed
Auxiliary Analog Information	65164	FE8C	441	Auxiliary Temperature #1
			1387	Auxiliary Pressure #1
Electronic Engine Control 3 (EEC3)	65247	FEDF	515	Engine's Desired Operating Speed
Shutdown	65252	FEE4	1081	Wait-to-Start Lamp
Engine Hours/Revolutions	65253	FEE5	247	Engine Total Hours of Operation
Fuel Consumption	65257	FEE9	250	Engine Total Fuel Used
Engine Temperature	65262	FEEE	110	Engine Coolant Temperature
			174	Engine Fuel Temperature
Engine Fluid Level/Pressure	65263	FEF6	94	Engine Fuel Delivery Pressure
			100	Engine Oil Pressure
			111	Engine Coolant Level
Fuel Economy (Liquid)	65266	FEF2	183	Engine Fuel Rate
Inlet/Exhaust Conditions	65270	FEF6	102	Engine Turbocharger Boost Pressure
			105	Engine Intake Manifold 1 Temperature
Vehicle Electrical Power	65271	FEF7	168	Electrical Potential (Voltage)
			158	Battery Potential (Voltage), Switched

18.1.2.1 Torque Speed Control 1 (TSC1): PGN 0

Identifier	Rate (msec)	PGN	Default Priority	DP	Source	Destination
0C 00 00 xx	10	0000	3	0	xx	00

Send	Receive	Subgroup Name	SPN	Byte	Bit	Length	State	Units	Resolution (unit/bit)	Range	
										Min	Max
		Engine Override Control Mode	695	1	1	2			binary	00b	11b
	X	Override Disabled					00				
	X	Speed Control					01				
		Torque Control					10				
	X	Speed/Torque Limit Control					11				
		Engine Requested Speed Control Conditions	696	1	3	2			binary	00b	11b
		Override Control Mode Priority	897	1	5	2			binary	00b	11b
		Not Defined	—	1	7	2					
	X	Engine Requested Speed/Speed Limit	898	2-3		16		rpm	0.125	0	8032
		Engine Requested Torque/Torque Limit	518	4		8		%	1	-125	125
		Not Defined	—	5-8							

The original SAE design for the TSC1 message was for truck applications as a temporary means for the transmission to override engine speed during gear shifts. More advanced system integration has evolved the use of the TSC1 message for use as a permanent means of controlling engine speed by off engine control systems. This is particularly common in machines that have complex hydraulic systems.

This is a powerful feature, but special care must be taken by the OEM with the implementation of TSC1 to ensure that the speed demanded of the engine is one that is safe and appropriate for the current operating conditions of the engine. It is the responsibility of the OEM to ensure that this is so and to perform the necessary risk assessment validation of the software for the electronic modules on the applications that are transmitting TSC1 speed demand messages to the engine.

Speed Control Mode — The engine control system will allow other modules to request engine speed for any length of time when operating in speed control mode. The TSC1 message will override any other engine speed demand, such as PWM throttle pedal input, to the engine speed governor. The transition from the hard wired speed demand input to CAN override speed demand is controlled by the engine speed governor and the rate of engine speed change is not limited by the engine acceleration rate limit configured via service tool. The one exception to TSC1 message overriding any other speed control is that the Speed Limit Control is nonfunctional when the engine is configured to Torque Governing (refer to Section 13.2). The OEM can control the rate of engine speed change when initiating override by ramping the requested speed from the speed demand prior to initiating override (broadcast in EEC3 message) to the desired speed demand at a controlled rate of change. A similar process can be followed prior to relinquishing override control, but this is only possible if the speed demand input that will regain control is known (i.e. determine from accelerator pedal position broadcast in EEC2).

Speed Limit Mode — The engine control system will allow other modules to limit engine speed for any period of time when operating in speed limit mode. The TSC1 message sets the maximum limit for the speed demand input to the engine speed governor. The transition to or from the requested speed limit is controlled by the engine speed governor and the rate of engine speed change is not limited by the engine acceleration rate limit configured via the service tool. The OEM can control the rate of engine speed change when initiating override by setting the requested speed limit to an engine speed greater than the speed demand prior to initiating override (broadcast in EEC3 message) and ramp the speed limit up or down at a controlled rate of change. Reverse process can be followed when removing the engine speed limit. Ramp the requested engine speed limit until the engine speed demand is no longer limited or speed demand limit is equal to high idle speed.

Destination Address — The engine control system responds to the TSC1 message with destination address 00, but does not monitor the source address of the TSC1 message. No restriction on the TSC1 message source has the following impact to the OEM:

- Messages from modules with any source address are accepted (i.e. TSC1 messages do not necessarily have to be sent by the transmission).
- The control system does not handle TSC1 messages differently based on message source.
- The engine control system has no means to arbitrate between speed requests or limits from more than one source, thus the OEM must ensure that TSC1 messages are not sent from more than one source at a time as failure to do so may result in erratic engine operation.

The engine control system needs to differentiate between the end of a transmission by another controller and an intermittent failure. The engine control expects, therefore, that when a controller no longer wishes to demand engine speed it will terminate with at least one message with the control override bits set to 00.

18.1.2.2 Electronic Transmission Controller 1 (ETC1): PGN 61442

Identifier	Rate (msec)	PGN	Default Priority	DP	Source	Destination
0C F0 02 03	10	F002	3	0	3	—

Send	Receive	Subgroup Name	SPN	Byte	Bit	Length	State	Units	Resolution (unit/bit)	Range	
										Min	Max
		Transmission Driveline Engaged	560	1	1	2			binary	00b	11b
		Torque Converter Lockup Engaged	573	1	3	2			binary	00b	01b
		Transmission Shift in Process	574	1	5	2			binary	00b	01b
		Not Defined	—	1	7	2					
	X	Transmission Output Shaft Speed	191	2-3		16		rpm	0.125	0	8031
		Percent Clutch Slip	522	4		8		%	0.4	0	100
		Engine Momentary Overspeed Enabled	606	5	1	2			binary	00b	11b
		Progressive Shift Disabled	607	5	3	2			binary	00b	11b
		Not Defined	—	5	5	4					
		Transmission Input Shaft Speed	161	6-7		16		rpm	0.125	0	8031
		Source Address of Controlling Device for Transmission Control	1482	8		8		none	1	0	250

Three cases are possible:

1. A transmission is present: If a transmission ECU (Source 3) is present on the CAN and it has sent an ETC1 message, then loss of the ETC1 message from the transmission address will result in a diagnostic from the engine ECU for loss of transmission data link.
2. A transmission is present: If a transmission is present on the CAN, but does not ever send an ETC1 message, then there is no diagnostic for the loss of transmission data link.
3. No transmission is present: If no transmission and therefore no transmission ECU is present, then an ETC1 message will not be sent, and there is no diagnostic for the loss of transmission data link.

18.1.2.3 Electronic Engine Controller 2 (EEC2): PGN 61443

Identifier	Rate (msec)	PGN	Default Priority	DP	Source	Destination
0C F0 03 00	50	F003	3	0	00	—

Send	Receive	Subgroup Name	SPN	Byte	Bit	Length	State	Units	Resolution (unit/bit)	Range	
										Min	Max
		Accelerator Pedal 1 Low Idle Switch	558	1	1	2			binary	00b	10b
		Accelerator Pedal Kickdown Switch	559	1	3	2			binary	00b	11b
		Road Speed Limit Status	1437	1	5	2			binary	00b	01b
		Accelerator Pedal 2 Low Idle Switch	2970	1	7	2			binary	00b	11b
X		Accelerator Pedal Position 1	91	2		8		%	0.4	0	100
X		Engine Percent Load at Current Speed	92	3		8		%	1	0	125
		Remote Accelerator Pedal Position	974	4		8		%	0.4	0	100
		Accelerator Pedal Position 2	29	5		8		%	0.4	0	100
		Vehicle Acceleration Rate Limit Status	2979	6	1	2			binary	00b	11b
		Not Defined	—	6	3	6					
		Not Defined	—	7-8							

Accelerator Pedal Position 1 — Accelerator pedal position broadcast is post arbitration. Only includes linear throttle sensors configured for throttle 1 and 2 inputs.

Engine Percent Load at Current Speed — The percent load calculation is not accurate at low loads or under transient conditions.

18.1.2.4 Electronic Engine Controller 1 (EEC1): PGN 61444

Identifier	Rate (msec)	PGN	Default Priority	DP	Source	Destination
0C F0 04 00	15	F004	3	0	00	—

Send	Receive	Subgroup Name	SPN	Byte	Bit	Length	State	Units	Resolution (unit/bit)	Range	
										Min	Max
		Engine Torque Mode	899	1	1	4			binary	0000b	1110b
		Not Defined	—	1	5	4					
		Drivers Demand Engine — Percent Torque	512	2		8		%	1	-125	125
X		Actual Engine — Percent Torque	513	3		8		%	1	-125	125
X		Engine Speed	190	4-5		16		rpm	0.125	0	8031
		Source Address of Controlling Device for Engine Control	1483	6		8		none	1	0	253
		Engine Starter Mode	1675	7	1	4			binary	0000b	1111b
		Not Defined	—	7	5	4					
		Engine Demand — Percent Torque	2432	8		8		%	1	-125	125

Broadcast Rate — The J1939 standard describes the frequency of transmission of this PGN as engine speed dependant. The ECU actually transmits the message every 15 ms irrespective of engine speed.

Engine Speed — Actual engine speed is set to 0 rpm when there is a fault detected with speed sensor measurement instead of EF00 as defined in standard. This avoids issues on engine crank with controls that do not correctly interpret the error code.

18.1.2.5 Auxiliary Analog Information: PGN 65164

Identifier	Rate (msec)	PGN	Default Priority	DP	Source	Destination
1C FE 8C 00	On req	FE8C	7	0	00	—

Send	Receive	Subgroup Name	SPN	Byte	Bit	Length	State	Units	Resolution (unit/bit)	Range	
										Min	Max
X		Auxiliary Temperature #1	441	1		8		°C	1	-40	210
		Auxiliary Temperature #2	442	2		8		°C	1	-40	210
X		Auxiliary Pressure #1	1387	3		8		kPa	16	0	4000
		Auxiliary Pressure #2	1388	4		8		kPa	16	0	4000
		Auxiliary Level	3087	5-6		16		mm	0.1	0	6425
		Not Defined	—	7-8		16					

18.1.2.6 Electronic Engine Controller 3 (EEC3): PGN 65247

Identifier	Rate (msec)	PGN	Default Priority	DP	Source	Destination
18 FE DF 00	250	FEDF	6	0	00	—

Send	Receive	Subgroup Name	SPN	Byte	Bit	Length	State	Units	Resolution (unit/bit)	Range	
										Min	Max
		Nominal Friction — Percent Torque	514	1	1	8		%	1	-125	125
X		Engine Desired Operating Speed	515	2-3		16		rpm	0.125	0	8031
		Engine Desired Operating Speed Asymmetry Adjustment	519	4		8		ratio	1	0	250
		Estimated Engine Parasitic Losses — Percent Torque	2978	5		8		%	1	-125	125
		Not Defined	—	6-8		24					

Engine Desired Operating Speed — Engine desired operating speed is the speed at which the engine would run if all load were removed and current speed demand conditions maintained. This is also the resulting arbitrated speed demand from all speed demand inputs and CAN override speed.

18.1.2.7 Shutdown: PGN 65252

Identifier	Rate (msec)	PGN	Default Priority	DP	Source	Destination
18 FE E4 00	1000	FEE4	6	0	00	—

Send	Receive	Subgroup Name	SPN	Byte	Bit	Length	State	Units	Resolution (unit/bit)	Range	
										Min	Max
		Engine Idle Shutdown Has Shut Down Engine	593	1	1	2			binary	00b	01b
		Engine Idle Shutdown Driver Alert Mode	594	1	3	2			binary	00b	01b
		Engine Idle Shutdown Timer Override	592	1	5	2			binary	00b	01b
		Engine Idle Shutdown Timer State	590	1	7	2			binary	00b	01b
		Not Defined	—	2	1	6					
		Engine Idle Shutdown Timer Function	591	2	7	2			binary	00b	01b
		A/C High Pressure Fan Switch	985	3	1	2			binary	00b	01b
		Refrigerant Low Pressure Switch	875	3	3	2			binary	00b	01b
		Refrigerant High Pressure Switch	605	3	5	2			binary	00b	01b
		Not Defined	—	3	7	2					
		Engine Wait-to-Start Lamp	1081	4	1	2			binary	00b	01b
X		Off					00				
X		On					01				
		Not Defined	—	4	3	6					
		Engine Protection System Has Shut Down Engine	1110	5	1	2			binary	00b	01b
		Engine Protection System Approaching Shutdown	1109	5	3	2			binary	00b	01b
		Engine Protection System Timer Override	1108	5	5	2			binary	00b	01b
		Engine Protection System Timer State	1107	5	7	2			binary	00b	01b
		Not Defined	—	6	1	6					
		Engine Protection System Configuration	1111	6	7	2			binary	00b	01b
		Engine Alarm Acknowledge	2815	7	1	2			binary	00b	11b
		Engine Alarm Output Command Status	2814	7	3	2			binary	00b	11b
		Engine Air Shutoff Command Status	2813	7	5	2			binary	00b	11b
		Engine Overspeed Test	2812	7	7	2			binary	00b	11b

Shutdown PGN only broadcasts on C7 and C9 engines, and intake air heater control feature is enabled.

Wait-to-Start Lamp — Intake air heater control strategy determines the status of the wait-to-start lamp parameter. The status is set to “ON” when the intake air heater strategy is in preheat mode during which the engine speed should remain at 0 rpm.

18.1.2.8 Engine Hours/Revolutions: PGN 65253

Identifier	Rate (msec)	PGN	Default Priority	DP	Source	Destination
18 FE E5 00	1000	FEE5	6	0	00	—

Send	Receive	Subgroup Name	SPN	Byte	Bit	Length	State	Units	Resolution (unit/bit)	Range	
										Min	Max
X		Engine Total Hours of Operation	247	1-4		32		hr	0.05	0	210,554,060
		Engine Total Revolutions	249	5-8		32		rev	1000	0	4,211,081,215,000

The SAE standard defines this PGN as send “on request.” There are some gauges and displays on the market which require this to be broadcast to display correctly, thus the engine control system will broadcast at a low update rate (1 sec) to ensure compatibility with these devices.

18.1.2.9 Fuel Consumption: PGN 65257

Identifier	Rate (msec)	PGN	Default Priority	DP	Source	Destination
18 FE E9 00	On Req	FEE9	6	0	00	—

Send	Receive	Subgroup Name	SPN	Byte	Bit	Length	State	Units	Resolution (unit/bit)	Range	
										Min	Max
		Engine Trip Fuel	182	1-4	1	32		L	0.5	0	2,105,540,607
X		Engine Total Fuel Used	250	5-8	1	32		L	0.5	0	2,105,540,607

Total Fuel Used — This parameter is not a direct measurement. It is an estimation based on standard test fuel at standard test temperatures. It is recommended, therefore, that this value be taken as an indication only of the fuel used by an engine.

18.1.2.10 Engine Temperature (ET1): PGN 65262

Identifier	Rate (msec)	PGN	Default Priority	DP	Source	Destination
18 FE EE 00	1000	FEEE	6	0	00	—

Send	Receive	Subgroup Name	SPN	Byte	Bit	Length	State	Units	Resolution (unit/bit)	Range	
										Min	Max
X		Engine Coolant Temperature	110	1		8		°C	1	-40	210
X		Engine Fuel Temperature	174	2		8		°C	1	-40	210
		Engine Oil Temperature 1	175	3-4		16		°C	.03125	-273	1735
		Engine Turbocharger Oil Temperature	176	5-6		16		°C	.03125	-273	1735
		Engine Intercooler Temperature	52	7		8		°C	1	-40	210
		Engine Intercooler Thermostat Opening	1134	8		8		%	0.4	0	100

Fuel Temperature — This parameter is only available on C11, C13, C15, and C18 engines.

18.1.2.11 Engine Fluid Level/Pressure (EFL/P1): PGN 65263

Identifier	Rate (msec)	PGN	Default Priority	DP	Source	Destination
18 FE EF 00	500	FEEF	6	0	00	—

Send	Receive	Subgroup Name	SPN	Byte	Bit	Length	State	Units	Resolution (unit/bit)	Range	
										Min	Max
X		Engine Fuel Delivery Pressure	94	1		8		kPa	4	0	1000
		Engine Extended Crankcase Blow-by Pressure	22	2		8		kPa	.05	0	12.5
		Engine Oil Level	98	3		8		%	0.4	0	100
X		Engine Oil Pressure	100	4		8		kPa	4	0	1000
		Engine Crankcase Pressure	101	5		16		kPa	1/128	-250	251
		Engine Coolant Pressure	109	7		8		kPa	2	0	500
X		Engine Coolant Level	111	8		8		%	0.4	0	100

Engine Fuel Delivery Pressure — Fuel delivery pressure is defined in the SAE standard as the fuel in the system as delivered from the supply pump to the injection pump. Caterpillar industrial engines with HEUI and MEUI fuel systems have fuel pressure sensors located in the position specified by the SAE standard, assuming the injector is a form of injection pump.

Engine Coolant Level — This SPN is intended for linear coolant level measurement between minimum and maximum level. The coolant level input to the engine control system is a switch type sensor, thus this sensor can only detect when coolant goes below a fixed level. Legacy product supported this PGN to display coolant level at 0 percent (level low) and 100 percent (level good), thus current product will continue to support this PGN in the same way for any legacy display and monitoring systems. The preferred method to monitor coolant level via a switch input is to monitor DM1 messages for an active diagnostic code when the coolant level low condition is detected.

18.1.2.12 Fuel Economy — Liquid (LFE): PGN 65266

Identifier	Rate (msec)	PGN	Default Priority	DP	Source	Destination
18 FE F2 00	100	FEF2	6	0	00	—

Send	Receive	Subgroup Name	SPN	Byte	Bit	Length	State	Units	Resolution (unit/bit)	Range	
										Min	Max
X		Engine Fuel Rate	183	1-2	1	16		L/hr	0.05	0	3212
		Engine Instantaneous Fuel Economy	184	3-4	1	16		km/kg	1/512	0	125.5
		Engine Average Fuel Economy	185	5-6	1	16		km/kg	1/512	0	125.5
		Engine Throttle Position	51	7	1	8		%	0.4	0	100
		Not Defined	—	8	1	8					

Engine Fuel Rate — The engine control system does not directly measure total fuel flow, thus fuel rate is a calculated parameter based on related engine information. It is recommended, therefore, that this value be taken as an indication only of the fuel quantity injected.

18.1.2.13 Inlet/Exhaust Conditions (IC): PGN 65270

Identifier	Rate (msec)	PGN	Default Priority	DP	Source	Destination
18 FE F6 00	500	FEF6	6	0	00	—

Send	Receive	Subgroup Name	SPN	Byte	Bit	Length	State	Units	Resolution (unit/bit)	Range	
										Min	Max
		Engine Particulate Trap Inlet Pressure	81	1		8		kPa	0.5	0	125
X		Engine Turbocharger Boost Pressure	102	2		8		kPa	2	0	500
X		Engine Intake 1 Manifold Temperature	105	3		8		°C	1	-40	210
		Engine Air Inlet Pressure	106	4		8		kPa	2	0	500
		Engine Air Filter Differential Pressure	107	5		8		kPa	0.05	0	12.5
		Engine Exhaust Gas Temperature	173	6-7		16		°C	.03125	-273	1735
		Engine Coolant Filter Differential Pressure	112	8		8		kPa	.5	0	125

Engine Turbocharger Boost Pressure — The engine control system will limit boost pressure to 0 kPa even though it is possible that a slight depression at the inlet will result in negative boost pressure on some engines when running at low idle speed.

18.1.2.14 Vehicle Electrical Power (VEP): PGN 65271

Identifier	Rate (msec)	PGN	Default Priority	DP	Source	Destination
18 FE F7 00	1000	FEF7	6	0	00	—

Send	Receive	Subgroup Name	SPN	Byte	Bit	Length	State	Units	Resolution (unit/bit)	Range	
										Min	Max
		Net Battery Current	114	1		8		amp	1	-125	125
		Alternator Current	115	1		8		amp	1	0	250
		Alternator Potential (Voltage)	167	3-4		16		V	0.05	0	3212
X		Electrical Potential (Voltage)	168	5-6		16		V	0.05	0	3212
X		Battery Potential (Voltage), Switched	158	7-8		16		V	0.05	0	3212

Battery/Electrical Potential — The engine control system measures voltage between the battery positive and battery negative terminals of the engine control. This value is used for both electrical potential and battery potential parameters.

18.1.3 Supported Parameters — Section 73: Diagnostics

This section defines the engine control system support and implementation of parameter groups defined in the diagnostic application layer of the SAE J1939 standard (J1939-73). These parameter groups are used by devices on the CAN bus for monitoring and displaying engine diagnostic information.

The message identifier, update rate, and parameter group definition is specified for each supported parameter group. Any deviation from the SAE recommended practice is noted below each parameter group table.

18.1.2.15 Engine Configuration: PGN 65251

Identifier	Rate (sec)	PGN	Default Priority	DP	Source	Destination
18 FE E3 00	5	FEE3	6	0	00	—

Send	Receive	Subgroup Name	SPN	Byte	Bit	Length	State	Units	Resolution (unit/bit)	Range	
										Min	Max
X		Engine Speed at Idle, Point 1	188	1-2		2		rpm	.125 rpm/bit	0	8031
X		Percent Torque at Idle, Point 1	539	3		1		%	1%/bit	-125	125
X		Engine Speed at Point 2	528	4-5		2		rpm	.125 rpm/bit	0	8031
X		Percent Torque at Point 2	540	6		1		%	1%/bit	-125	125
X		Engine Speed at Point 3	529	7-8		2		rpm	.125 rpm/bit	0	8031
X		Percent Torque at Point 3	541	9		1		%	1%/bit	-125	125
X		Engine Speed at Point 4	530	10-11		2		rpm	.125 rpm/bit	0	8031
X		Percent Torque at Point 4	542	12		1		%	1%/bit	-125	125
X		Engine Speed at Point 5	531	13-14		2		rpm	.125 rpm/bit	0	8031
X		Percent Torque at Point 5	543	15		1		%	1%/bit	-125	125
X		Engine Speed at High Idle, Point 6	532	16-17		2		rpm	.125 rpm/bit	0	8031
		Gain (Kp) of the Endspeed Governor	545	18-19							
X		Reference Engine Torque	544	20-21		2		N•m	1 N•m/bit	0	64255
		Maximum Momentary Engine Override Speed, Point 7	533	22-23							
		Max. Momentary Override Time Limit	534	24							
X		Req. Speed Control Range Lower Limit	535	25		1		rpm	10 rpm/bit	0	2500
X		Req. Speed Control Range Upper Limit	536	26		1		rpm	10 rpm/bit	0	2500
		Req. Torque Control Range Lower Limit	537	27							
		Req. Torque Control range Upper Limit	538	28							
		Extended Range Req. Speed Control Range Upper Limit	1712								
		Engine Moment of Inertia	1794								
		Default Engine Torque Limit	1846								

The industrial engine control system supports the parameter group numbers (PGN) listed in the following table:

Parameter Group	PGN		SPN	Parameters Supported
	Dec	Hex		
Active Diagnostics Trouble Codes (DM1)	65226	FECA	623	Red stop lamp
			624	Amber warning lamp
			987	Protect lamp
			1214	SPN
			1215	FMI
			1706	SPN conversion method
			1216	Occurrence count
Previously Active Diagnostic Trouble Codes (DM2)	65227	FECE	623	Red stop lamp status
			624	Amber warning lamp status
			987	Protect lamp status
			1214	SPN
			1215	FMI
			1706	SPN conversion method
			1216	Occurrence count
Diagnostic Data Clear/Reset of Previously Active DTCs (DM3)	65228	FECC	—	

18.1.3.1 Active Diagnostics Trouble Codes (DM1): PGN 65226

Identifier	Rate (msec)	PGN	Default Priority	DP	Source	Destination
18 FE CA 00	1000	FECA	6	0	00	—

Send	Receive	Subgroup Name	SPN	Byte	Bit	Length	State	Units	Resolution (unit/bit)	Range	
										Min	Max
X		Protect Lamp	987	1	1	2			binary	00b	01b
X		Amber Warning Lamp	624	1	3	2			binary	00b	01b
X		Red Stop Lamp	623	1	5	2			binary	00b	01b
		Malfunction Indicator Lamp	1213	1	7	2			binary	00b	01b
		Reserved	—	2	1	8					
X		SPN — 8 Least Significant Bits	1214	3	1	8		none	hex	00h	FFh
X		SPN — Second Byte		4	1	8		none	hex	00h	FFh
X		SPN — 3 Most Significant Bits		5	6	3		none	hex	0h	7h
X		FMI	1215	5	1	5		none	hex	00h	1Fh
		SPN Conversion Method	1706	6	8	1			binary	0b	1b
X		Conversion Method 4					0				
		Conversion Method 1-3					1				
X		Occurrence Count	1216	6	1	7		counts	1	0	126

DM1 Broadcast Rate — The engine control system will only broadcast the DM1 message when there is an active fault detected. The message will then be broadcast at a one-second update rate. DM1 only identifies active faults, so a broadcast termination message is sent in the event all faults become inactive. The DM1 termination message is a single fault message with SPN/FMIs set to zero.

DM1 Message Identifier — If a single fault code is present, then DM1 will be sent as a single message with the identifier 18FECA00. If there is more than one fault code present, the DM1 message will be longer than eight bytes and the transport protocol will be used to send the message.

SPN Conversion Method — The SPN conversion method is transmitted as zero. The SPN is transmitted in the preferred format (version 4) described in the J1939-73 specification.

Lamp Status — The engine control system supports the DM1 lamp status parameter byte, but the Caterpillar definition of each lamp parameter differs from the parameter definition in the SAE J1939-73 standard. Caterpillar implementation uses these lamps to indicate levels of warning severity. The Caterpillar strategy defines these as Warning Category Indicators (WCI). There are three levels of warning indicators that have specific actions identified for each level. The engine control system definitions and support for the lamp status parameters are defined in the table on the following page:

Lamp Parameter	SAE J1939-73 Definition	Caterpillar Implementation
Malfunction Indicator Lamp	Lamp used to relay only emissions-related trouble code information.	Not supported
Red Stop Lamp	Lamp used to relay trouble code information that is of a severe enough condition that it warrants stopping the vehicle.	<p>Lamp status "ON" whenever there is at least one diagnostic trouble code with a warning category indicator = 3</p> <p>Generally used to indicate engine shutdown due to fault</p>
Amber Warning Lamp	Lamp used to relay trouble code information that is reporting a problem with the vehicle system, but the vehicle need not be immediately stopped.	<p>Lamp status "ON" whenever there is at least one diagnostic trouble code with a warning category indicator = 2</p> <p>Generally used to indicate engine in derate due to fault</p>
Protect Lamp	Lamp used to relay trouble code information that is reporting a problem with a vehicle system that is most probably not electronic subsystem related. For instance, engine coolant temperature is exceeding its prescribed temperature range.	<p>Lamp status "ON" whenever there is at least one diagnostic trouble code with a warning category indicator = 1</p> <p>Generally used for warning only</p>

18.1.3.2 Previously Active Diagnostic Trouble Codes (DM2): PGN 65227

Identifier	Rate (msec)	PGN	Default Priority	DP	Source	Destination
18 FE CB 00	1000	FECB	6	0	00	—

Send	Receive	Subgroup Name	SPN	Byte	Bit	Length	State	Units	Resolution (unit/bit)	Range	
										Min	Max
X		Protect Lamp	987	1	1	2			binary	00b	01b
X		Amber Warning Lamp	624	1	3	2			binary	00b	01b
X		Red Stop Lamp	623	1	5	2			binary	00b	01b
		Malfunction Indicator Lamp	1213	1	7	2			binary	00b	01b
		Reserved	—	2	1	8					
X		SPN — 8 Least Significant Bits	1214	3	1	8		none	hex	00h	FFh
X		SPN — Second Byte		4	1	8		none	hex	00h	FFh
X		SPN — 3 Most Significant Bits		5	6	3		none	hex	0h	7h
X		FMI	1215	5	1	5		none	hex	00h	1Fh
		SPN Conversion Method	1706	6	8	1			binary	0b	1b
X		Conversion Method 4					0				
		Conversion Method 1-3					1				
X		Occurrence Count	1216	6	1	7		counts	1	0	126

DM2 Broadcast Rate — The engine control system will only broadcast the DM2 message when there is a previously active fault logged in the engine control system's non-volatile memory. The message will then be broadcast at a one-second update rate. DM2 only identifies logged faults, so a broadcast termination message is sent in the event all faults are cleared from memory. The DM2 termination message is a single fault message with SPN/FMIs set to zero.

All other application notes for message identifier, SPN conversion method, and lamp status for DM1 also apply to the DM2 message.

18.1.3.3 Diagnostic Data Clear/Reset of Previously Active DTCs (DM3): PGN 65228

Identifier	Rate (msec)	PGN	Default Priority	DP	Source	Destination
18 FE CC 00	On Req	FECC	6	0	00	—

Send	Receive	Subgroup Name	SPN	Byte	Bit	Length	State	Units	Resolution (unit/bit)	Range	
										Min	Max
X		Request to Clear Fault Codes									

This message is sent as a request PGN. When the ECU receives a DM3 message, it will clear all diagnostic codes but not event codes. The ECU will send an acknowledge (ACK) message to say that this action is complete.

Diagnostic codes are those that relate to faults of the electronic system (e.g. sensor failure). Event codes are those where there is a problem with the engine operation (e.g. coolant temperature high warning).

Event codes can only be cleared with the service tool and require a factory password.

18.1.4 Supported Parameters — Section 21: Data Link Layer

18.1.4.1 Transport Protocol — Connection Management (TP, CM)

Identifier	Rate (msec)	PGN	Default Priority	DP	Source	Destination
1C EC FF 00	—	EC00	7	0	—	—

Support as per J1939-21. Note that the transport protocol is used principally for sending messages larger than eight bytes of data (e.g. diagnostic messages DM1 and DM2). This is achieved by sending a broadcast announce message (TP.CM_BAM) which describes the PGN to be sent, the number of bytes of data, and the number of packets into which it is to be divided. The actual data will follow in data transfer packets (TP.DT) as described in the following sections.

18.1.4.2 Transport Protocol — Data Transfer (TP, DT)

Identifier	Rate (msec)	PGN	Default Priority	DP	Source	Destination
1C EB FF 00	—	EB00	7	0	—	—

If a module is required to decode any information that is sent via the transport protocol, then it must be capable of receiving and processing messages with the same identifier within 50 ms.

18.1.4.3 Acknowledge

Identifier	Rate (msec)	PGN	Default Priority	DP	Source	Destination
18 E8 xx xx	—	E800	6	0	—	—

Both acknowledge (ACK) and negative acknowledge (NACK) are supported as per the J1939 specification.

18.1.4.4 Parameter Group (PG) Request

Identifier	Rate (msec)	PGN	Default Priority	DP	Source	Destination
18 EA xx xx	—	EA00	6	0	—	—

Support as per the J1939 specification. This PGN is sent to the ECU to request parameters that are only sent “on request.” For example, if an electronic module on the machine requires engine hours information, it must send a request PGN for the engine hours/revolutions PGN.

The engine system is to support PGN 59904 (00EA00), providing the capability to respond to requests for parameter group information globally or from a specific destination. This feature will allow any module on the J1939 data link to access information in the engine system supported parameter list. Response to the parameter group request will comply with request response requirements defined in SAE recommended practice for J1939 data link layer (J1939-21).

18.1.5 Supported Parameters — Section 81: Network Management

The engine does support the network initialization requirements as outlined in Specification J1939-81.

This includes the claiming of addresses. The engine will always claim address zero and will not accept any other address.

Most off-highway machines do not implement this section of the specification. If further information on this subject is required, however, please contact the electronic applications team directly.

18.2 Caterpillar Data Link

For industrial engines, the Caterpillar Data Link (CDL) is principally used for service tool support. If an application does have a requirement to communicate with another system on CDL, for example with a Caterpillar transmission or a display, please contact your local applications team for further information.

18.3 Other Data link Standards

18.3.1 CANopen

CANopen may become a popular choice for CAN higher level protocol in off-highway machines that use significant numbers of electro-hydraulic controllers.

If CANopen is used as the main communications standard in a vehicle, then a J1939 gateway is required. A specification for a CANopen to J1939 gateway may be obtained from the website of “CAN in Automation (CIA).”

18.3.2 OEM Proprietary CAN Standards

It is accepted that the J1939 standard cannot meet all the diverse needs of the many specialized applications in the off-highway market. The OEM may have to use a small number of proprietary messages on the same bus as the J1939 messages. If a large number of proprietary messages are required for an application, the machine designer should consider the use of a CAN gateway to isolate the proprietary messages from the J1939 bus. There is also a risk that OEM-defined messages will clash with some of the J1939 standard messages.

A Appendix

Appendix A.1 ECU Interface Requirements

A 1.1 PWM Input

The PWM input measures the frequency and duty cycle of a 500 Hz PWM signal. The input is a single-ended digital input. The signal input is to switch between 0 VDC (max 1.0 VDC) low state and 5 VDC (min 3.75 VDC, max 24 VDC) high state. The normal operating range for the 500 Hz PWM signal duty cycle is 5% to 95% and frequency is 150 Hz to 1000 Hz. Signal operation outside of this range will result in an abnormal signal diagnostic code on the ECU.

Connection of the PWM signal to the ECU should be through wire size of #16 to #18 AWG with a wire specification that meets SAE J1128 for low-tension primary cable, type SXL. Reference Connectors and Wiring Harness Requirements section for more information on wire selection.

A 1.2 Switch to Ground Input

The information in this section is general knowledge for connecting switches to the ECU switch to ground input. Specific information for a particular switch is located with the engine feature to which the switch belongs. Switch to ground inputs on the ECU are all pulled up to an internal power supply.

A 1.2.1 Measuring Voltage in Switch Circuits

Voltage that is supplied from the ECU to the switches will not normally exceed 13 VDC, regardless of the system voltage.

When any of the switch contacts are closed, the voltage drop through the switch circuit must be less than 1.4 VDC. This measurement should be taken at the ECU pin that supplies the switch and at the negative battery input to the ECU. This measurement includes the following values:

- Ground Potential Differences
- Voltage Drop Across the Switch
- Voltage Drop Across the Wiring Harness

When a switch contact is opened or the wiring harness has an open circuit, the internal pull-up voltages of the ECU force the respective input to 13 VDC. Closing an OEM-installed switch must short circuit the switch input to the negative battery ground stud that is located near the ECU customer connector (J1/P1). Refer to the Power and Grounding Considerations section of this publication.

Switch Status	Measured Voltage (VDC)
Closed	< 1.4 VDC
Open	> 2.4 VDC

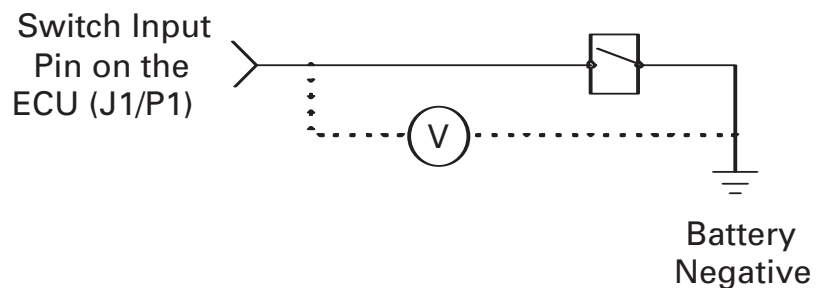

V = voltage measurement with digital multimeter

A 1.2.2 Measuring Current in Switch Circuits

Normal current output from the ECU through the switches ranges from a minimum of 6 mA to maximum of 10 mA. Current may flow through unintended paths. Possible paths for current leakage may exist within the following components:

- Connectors
- Harnesses
- Switches

Switch Status	Measured Current (I)
Closed	6-10 mA
Open	0 mA

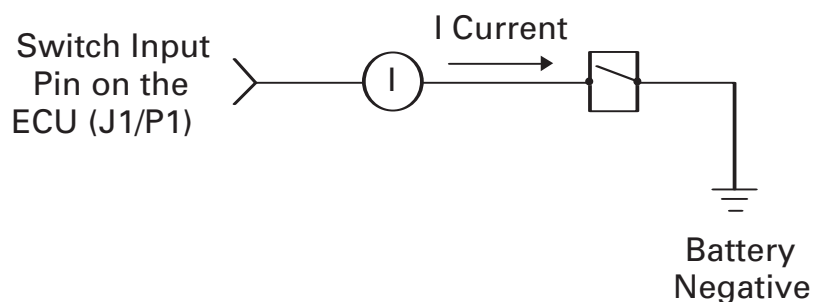

I = current measurement with digital multimeter

A 1.2.3 Measuring Resistance in Switch Circuits

When any of the switch contacts are open, the resistance between the pin that supplies the switch and at the negative battery input to the ECU should be greater than 4,000 ohms.

Switch Status	Measured Resistance (R)
Closed	< 50 ohms
Open	> 4K ohms

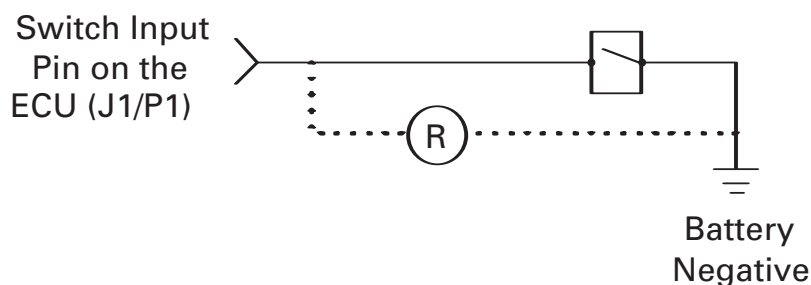

R = resistance measurement with digital multimeter

A 1.3 High-Side Current Driver (2 A) Output

The high-side current driver (2 A) output is a digital output that is switched to battery for driving a source that has a continuous current draw that is less than or equal to 2 A. This output is typically used to control devices such as LEDs, relays, and solenoids that require large amounts of current. These drivers are capable of functioning during engine cranking, jumpstart, and load dump, although the driver output voltage will depend directly upon the instantaneous voltage applied to the ECU battery positive and negative inputs.

The driver sources (delivers) current through the device to a return pin located on the ECU. The amount of current sourced depends on the resistance of the device and on the system battery voltage. The ECU limits the sourced current to approximately 3.5 A to handle “in-rush” conditions. The driver will turn off automatically when a “load dump” is present and will turn back on when the “load dump” has dissipated. Any load connected to the driver should be able to withstand “load dumps.”

The ECU will source 2.0 A at normal operating conditions. The maximum leakage current with the driver off is 1 mA. At cold operating conditions, the ECU may source as low as 1.0 A to the solenoid or relay. Select components that normally operate between 1.0 A and 2.0 A. The driver application must not be designed to source more than 2.0 A. Caterpillar recommends that transient suppression is used on inductive load in addition to the ECU internal protection.

Connection of the high-side current driver output to the ECU should be through wire size of #14 to #16 AWG with a wire specification that meets SAE J1128 for low-tension primary cable, type SXL. Reference Connectors and Wiring Harness Requirements section for more information on wire selection.

A 1.4 Low-Side Current Driver (300 mA) Output

The low-side ECU driver provides a path to the negative battery terminal in order to activate the device (lamp, etc.) that is connected to the circuit. While circuit protection is recommended for the lamp driver circuit, Caterpillar does not require dedicated circuit protection.

When the ECU turns the driver on, the output pin will be within about 1 volt of the ECU negative battery terminal. The driver is designed to sink 300 mA over the ECU operating temperature range. The maximum leakage current with the driver off is 1 mA.

The driver will sink more than 300 mA briefly to handle “in-rush” situations such as turning on incandescent lights. Resistances for incandescent lamps or other dynamic devices are typically 10 percent of the steady state value for up to 150 ms when current is limited to 300 mA. Under these conditions, the driver shall not pulse on and off or current limit until the load reaches steady state resistance.

The ECU is capable of detecting if continuous current exceeds 300 mA. The driver must never be expected to sink more than 300 mA continuous current. The driver will turn off automatically when a “load dump” is present and will turn back on when the “load dump” has dissipated. Any load connected to the driver should be able to withstand “load dumps.”

The lamps are to be connected to battery (+) to provide power to drive the lamps on. If the driver is connected to a discrete load (lamp, buzzer, etc.) the battery (+) connection for the load should be switched. Avoid having battery (+) connected to the load while the ECU is off.

Connection of the low-side driver to the ECU should be through wire size of #16 to #18 AWG with a wire specification to meet SAE J1128 for low-tension primary cable, type SXL. Reference Connectors and Wiring Harness Requirements section for more information on wire selection.

A 2 ECU Connector (J1/P1) Pinout & Load Table

Pin	Wire	Signal	Assignment	Voltage	Current	Pin	Wire	Signal	Assignment	Voltage	Current
1			Unused			36			Unused		
2	18 AWG	Supply	Analog Sensor Power (+5v)	5 VDC	40 mA	37			Unused		
3	18 AWG	Common Ground	Analog Sensor Return			38			Unused		
4	18 AWG	Supply	Digital Sensor Power (+8v)	8 VDC	40 mA	39			Unused		
5	18 AWG	Common Ground	Digital Sensor Return			40	18 AWG	Switch to Ground	Retarder Solenoid Medium/High or Exhaust Brake Enable	13 VDC	6.5 mA
6	18 AWG	Switch to Ground	Maintenance Clear Switch	13 VDC	6.5 mA	41	18 AWG	Switch to Ground	PTO Interrupt Switch	13 VDC	6.5 mA
7	18 AWG	Switch to Ground	Torque Limit Switch	13 VDC	6.5 mA	42	18 AWG	Data Link	J1939 Shield	Per J1939	
8	18 AWG	Data Link +	Cat Data Link (+)	5 VDC	100 mA	43			Unused		
9	18 AWG	Data Link -	Cat Data Link (-)	5 VDC	100 mA	44	18 AWG	Switch to Ground	Remote Shutdown Switch	13 VDC	6.5 mA
10	16 AWG	High Side	Ether Start Valve Solenoid/Relay ⁽¹⁾	Battery	2 Amp	45	18 AWG	Switch to Ground	Intermediate Speed Switch	13 VDC	6.5 mA
11	16 AWG	High Side	Air Shutoff Relay	Battery	2 Amp	46			Unused		
12			Unused			47			Unused		
13	16 AWG	High Side	Exhaust Brake Driver	Battery	2 A	48	14 AWG	Supply	+ Battery Un-switched	Battery	10 Amp
14			Unused			49	18 AWG	Switch to Ground	Coolant Level Switch	5 VDC	10 mA
15	18 AWG	Analog Input	Auxiliary Pressure Sensor	5 VDC	20 mA	50	18 AWG	Data Link	J1939 (+)	Per J1939	
16	16 AWG	Passive Analog Input	Auxiliary Temperature Sensor	5 VDC	10 mA	51			Unused		
17			Unused			52	14 AWG	Supply	+ Battery Un-switched	Battery	10 Amp
18			Unused			53	14 AWG	Supply	+ Battery Un-switched	Battery	10 Amp
19			Wait to Start Lamp		2.0 A	54	18 AWG	Switch to Ground	Overspeed Verify Switch	13 VDC	0.6 mA
20			Unused			55	14 AWG	Supply	+ Battery Un-switched		10 Amp
21			Unused			56	18 AWG	Switch to Ground	PTO Enable Switch	13 VDC	6.5 mA
22			Unused			57			DO NOT USE		
23	18 AWG	Switch to Ground	Retarder Solenoid Low/High	13 VDC	6.5 mA	58	18 AWG	Switch to Ground	PTO Ramp Up/Set Switch	13 VDC	6.5 mA
24	18 AWG	Low Side	Timing Cal Input	Battery	0.3 A	59			Unused		
25			Timing Cal Input		0.3 A	60	18 AWG	Switch to Ground	PTO Ramp Down/Resume	13 VDC	6.5 mA
26			Unused			61	14 AWG	Ground	- Battery		
27			Unused			62			Unused		
28	18 AWG	Low Side	Diagnostic Lamp	Battery	0.3 A	63	14 AWG	Ground	- Battery	- Battery	10 Amp
29	18 AWG	Low Side	Warning Lamp	Battery	0.3 A	64			Unused		
30	18 AWG	Low Side	Maintenance Due Lamp	Battery	0.3 A	65	14 AWG	Ground	- Battery	-Battery	10 Amp
31	18 AWG	Low Side	Retarder Lamp	Battery	0.3 A	66	18 AWG	PWM Input	Throttle Position Sensor	5 VDC	40 mA
32			Unused			67	14 AWG	Common Ground	ASO Solenoid Common	- Battery	10 Amp
33			Unused			68			Unused		
34	18 AWG	Data Link	J1939 (-)	Per J1939		69	14 AWG	Ground	- Battery	- Battery	10 Amp
35			Unused			70	18 AWG	Switch to + Battery	Key Switch Input	Battery	1.2 mA

⁽¹⁾ If Caterpillar industrial engine ether kits are used, no relay is necessary in this circuit. See Section 16.1 for more information.

A 3 Customer Harness Connector (J61/P61) Pinout Table

Description	ECU (J61/P61) Pin	Customer Harness (J1/P1) Pin
Battery (+): Un-switched	1	48
Torque Limit Switch	2	7
Retarder Lamp	3	31
Air Shutoff Solenoid	4	11
Solenoid Common	5	67
Cat Data Link (-)	6	9
Cat Data Link (+)	7	8
Digital Sensor Power (+8v)	8	4
Digital Sensor Return	9	5
Throttle Position Sensor	10	66
Auxiliary Temperature Sensor	11	16
Maintenance Clear Switch	12	6
Maintenance Due Lamp	13	30
Analog Sensor Power (+5v)	14	2
Analog Sensor Return	15	3
J1939 Data Link Shield	16	42
J1939 Data Link (+)	17	50
J1939 Data Link (-)	18	34
PTO Interrupt Switch	19	41
Unused	20	68
Unused	21	59
Ether Start Valve	22	10
Unused — not yet supported	23	35
Diagnostic Lamp	24	28
Warning Lamp	25	29
Battery (+): Switched	26	70
Remote Shutdown Switch	27	44
Intermediate Engine Speed Switch	28	45
PTO Enable Switch	29	56
PTO Ramp Up/Set Switch	30	58
Battery (+): Un-switched	31	52
Battery (+): Un-switched	32	53
Auxiliary Pressure Sensor	33	15
Retarder Solenoid Low/High Switch	34	23
Retarder Solenoid Medium/High Switch (C15 & C18) HEUI Exhaust Brake Enable (C7 & C9)	35	40
Coolant Level Sensor	36	49
Battery (+): Un-switched	37	55
Unused	38	22
PTO Ramp Down/Resume Switch	39	60
Overspeed Verify Switch	40	54

A 4 Customer Configuration Parameter Table

SYSTEM CONFIGURATION PARAMETERS			
Parameter	Available Range or Options	Default	Required Password
ECU Identification Parameters			
Equipment ID	17 Alphanumeric Characters	NOT PROGRAMMED	None
Engine Serial Number	0XX00000 or XXX00000	0XX00000	None
ECU Serial Number	Read Only ⁽¹⁾	Read Only ⁽¹⁾	Read Only ⁽¹⁾
Personality Module PN	Read Only ⁽¹⁾	Read Only ⁽¹⁾	Read Only ⁽¹⁾
Software Gp Release Date	Read Only ⁽¹⁾	Read Only ⁽¹⁾	Read Only ⁽¹⁾
Selected Engine Rating			
Rating Number	Software Dependent	Software Dependent	Customer
Rated Power	Read Only ⁽¹⁾	Read Only ⁽¹⁾	Read Only ⁽¹⁾
Rated Peak Torque	Read Only ⁽¹⁾	Read Only ⁽¹⁾	Read Only ⁽¹⁾
Top Engine Speed Range	Read Only ⁽¹⁾	Read Only ⁽¹⁾	Read Only ⁽¹⁾
Test Specifications	Read Only ⁽¹⁾	Read Only ⁽¹⁾	Read Only ⁽¹⁾
Top Engine Limit	Software Dependent	Software Dependent	Customer
Engine Acceleration Rate	10 to 1000	500	None
Low Idle Speed	600 to 1400	700	None
PTO Mode	Ramp Up/Ramp Down or Set/Resume	Ramp Up/Ramp Down	None
High Idle Speed	Software Dependent	Software Dependent	Customer
Intermediate Engine Speed	Programmed Low Idle to TEL	Programmed Low Idle	None
Maximum Engine Torque Limit	Software Dependent	Software Dependent	None
Customer Password #1	8 Alphanumeric Characters	Blank	Customer ⁽²⁾
Customer Password #2	8 Alphanumeric Characters	Blank	Customer ⁽²⁾
FLS (Full Load Setting)	Factory Programmed	Factory Programmed	Factory
FTS (Full Torque Setting)	Factory Programmed	Factory Programmed	Factory
Ether Control	Enabled or Disabled	Disabled	None
Ether Configuration	Continuous Flow or Uninstalled	Uninstalled	None
Air Inlet Heater Installation Status (C7 and C9 Only)	Installed or Not Installed	Installed	Customer
Air Shutoff	Enabled or Disabled	Disabled	None
Maintenance Indicator Mode	OFF, Auto Fuel, Auto Hour, Man Fuel, or Man Hour	OFF	None
PM1 Interval	100 to 750 Hours or 3785 to 28390 L (1000 to 7500 U.S. gal)	250 Hours or 9463 L (2500 U.S. gal)	None
Throttle Position Sensor	Installed or Not Installed	Not Installed	None
Coolant Level On	Installed or Not Installed	Not Installed	None
Auxiliary Temperature Sensor Installation Status	Installed or Not Installed	Not Installed	None
Auxiliary Pressure Sensor Installation Status	Installed or Not Installed	Not Installed	None
Engine Retarder Enable Command (C15 and C18 Only)	Enabled or Disabled	Disabled	None
Exhaust Valve Actuation Installation Status (C7 and C9 Only)	Installed or Not Installed	Not Installed	None
Throttle Input Low Idle Duty Cycle Setpoint	10% to 40%	10	None
Throttle Input High Idle Duty Cycle Setpoint	50% to 90%	90	None
Engine Governor Primary Mode Configuration	Torque Control or Speed Control	Speed Control	None
Run Out Control	On/Off	Off	None
Total Tattletale	Read Only ⁽¹⁾	Read Only ⁽¹⁾	Read Only ⁽¹⁾

⁽¹⁾ The parameter can be viewed only. No changes are allowed.

⁽²⁾ Factory passwords are required in order to reprogram the customer passwords.

A 5 Customer Configuration Parameter Worksheet

Providing the customer with a printed copy of the “Configuration” and the “Monitoring System” screens from Cat ET is good practice. The following table may be copied for the customer.

Parameter	Value
Equipment ID	
Engine Serial Number	
ECU Serial Number	
Personality Module Part Number	
Software Gp Release Date	
Rating Number	
Rated Power	
Rated Peak Torque	
Top Engine Speed Range	
Test Specifications	
Top Engine Limit	
Engine Acceleration Rate	
Low Idle Speed	
PTO Mode	
High Idle Speed	
Intermediate Engine Speed	
Maximum Engine Torque Limit	
Customer Password #1	
Customer Password #2	
FLS	
FTS	
Ether Control	
Ether Configuration	
Air Inlet Heater Installation Status (C7 and C9 Only)	
Air Shutoff	
Maintenance Indicator Mode	
PM1 Interval	
Throttle Position Sensor	
Coolant Level Sensor	
Engine Retarder Enable Command	
Exhaust Valve Actuation Installation Status (C7 and C9 Only)	
Last Tool to Change Customer Parameters	
Last Tool to Change System Parameters	
Auxiliary Pressure Sensor Installation Status	
Auxiliary Temperature Sensor Installation Status	
Throttle Input High Idle Duty Cycle	
Throttle Input Low Idle Duty Cycle	
Engine Governor Primary Mode Configuration	
Total Tattletale	
Run Out Control	
Information from Engine Information Plate	
Engine Serial Number	
FLS	
FTS	

A 6 Engine Monitoring System Parameter Table

NOTE: For some parameters, start-up delays also apply. Refer to relevant portion of Section 15 for specific start-up time delay information.

Parameter	Action ⁽³⁾	Default Value	Time Delay in Seconds		Set Points	
			Range	Default	Range	Default
Low Engine Oil Pressure	Warning	On	None	8	MAP	Maps are not programmable. ⁽¹⁾
	Derate	On		8		
	Shutdown	Off		4		
High Coolant Temperature	Warning	On	None	10	C7 85° C to 108° C C9 85° C to 113° C C11 to C32 85° C to 110° C	C7 108° C C9 113° C C9 85° C to 113° C
	Derate	On	1 to 120s	10	C7 86° C to 111° C C9 86° C to 116° C C11 to C32 86° C to 111° C	C7 111° C C9 116° C C11 to C32 111° C
	Shutdown	Off	1 to 120s	10	C7 87° C to 111° C C9 87° C to 116° C C11 to C32 87° C to 111° C	C7 111° C C9 116° C C11 to C32 111° C
Engine Overspeed	Warning	On	None	1.0	C7/C9 1800 to 2600 C11 to C15 1800 to 2600 C18 1800 to 2500 C27/C32 1800 to 2600	C7/C9 2600 C11 to C15 2600 C18 2500 C27/C32 2600
	Shutdown	On	None	1.0	C7/C9 1800 to 2800 C11 to C15 1800 to 2800 C18 1800 to 2700 C27/C32 1800 to 2800	C7/C9 2800 C11 to C15 2800 C18 2700 C27/C32 2800
High Intake Air Temperature	Warning	On	None	8	C7/C9 65° C to 90° C C11 to C32 65° C to 82° C	C7/C9 90° C C11 to C32 82° C
	Derate	On	None	8	C7/C9 65° C to 110° C C11 to C32 65° C to 86° C	C7/C9 110° C C11 to C32 86° C
Low Coolant Level	Warning	On	1 to 120s	10	N/A	N/A
	Derate	On	1 to 120s	10		
	Shutdown	Off	1 to 120s	10		
High Fuel Temperature ⁽²⁾	Warning	On	1 to 120s	30	70° C to 90° C	90° C
	Derate	On	1 to 120s	10	71° C to 91° C	91° C
	Shutdown	Off	1 to 120s	10	71° C to 91° C	91° C
High Fuel Pressure	Warning	On	None	8	758 kPa(g)	758 kPa(g)
High Auxiliary Temperature	Warning	On	1 to 120s	4	0° C to 140° C	105° C
	Derate	Off	1 to 120s	4	0° C to 140° C	106° C
	Shutdown	Off	1 to 120s	4	0° C to 140° C	107° C
High Auxiliary Pressure ⁽²⁾	Warning	On	1 to 120s	4	0 kPa to 3050 kPa	1500 kPa
	Derate	Off	1 to 120s	3		
	Shutdown	Off	1 to 120s	3		

⁽¹⁾ The maps may be different. The maps depend on the model of the engine.

⁽²⁾ The engine must be equipped with the appropriate sensor.

⁽³⁾ All of the parameter actions may be turned off in Cat ET.

A 7 Switch Specifications

The OEM supplies all switches. All switches that are provided by the OEM and connected to the Electronic Control Unit (ECU) must be of a two-wire design. These switches must be externally connected to the negative battery ground stud. Do not use switches that are grounded internally to the case.

Momentary opening or closing of the switches and contact chatter should not exceed 100 milliseconds in duration. Vibration or shock that is normally found in the application should not cause opening or closing of the switches.

The plating on the contacts should not be susceptible to corrosion or oxidation. Gold-plated switch contacts are recommended.

If a problem occurs with an undetermined cause, connect Cat ET and observe the status of the switch. Refer to the appropriate troubleshooting service manual for your engine.

A 8 Installation Checklist

Following is a checklist of installation design parameters that result in the majority of start-up issues if not implemented correctly. Use this as a guide when reviewing installation design with the customer or OEM:

• Battery Connections

- Are all battery + and - leads connected to the ECU?
- Is circuit protection adequate (i.e., correct number of circuit breakers that are sized appropriately)?
- Is circuit protection in an easily accessible location?

• Is the engine grounded appropriately?

- Are all ground wires appropriately sized?
- Has any paint or debris been removed at ground stud locations to facilitate grounding?

• Do all relays and solenoids have adequate noise suppression (i.e., flyback diodes)?

• Is the starting system sized appropriately to crank the engine to the minimum required starting speed under anticipated parasitic load conditions and anticipated temperature extremes?

• Are all configuration parameters configured correctly?

- Are throttles appropriately configured and calibrated?

Note: Failure to properly set throttle input duty cycle will cause:

- Failure to reach low idle
- Failure to reach high idle
- Failure to reach full power
- Failure to activate compression brake

- Have configuration parameters been downloaded to a PC and saved? Printed and filed? Written down for future reference?

• Is the Monitoring System configured appropriately for the application?

• Will this application require operation at high altitude or low altitude? If so, contact your application support engineer.

- **Wiring**

- Are all wires sized appropriately?
- Are wire bend radii generous enough so that the connector remains sealed and there is no strain on the wires?
- Do unused pin locations have seal plugs installed?
- Are wiring harnesses routed away from high heat areas on the machine?
- Are wiring harnesses adequately supported? Are harness clips (p-clips or ladder clips) used to support and secure harnesses? Are runs between clip points short enough to allow adequate support?
- Are there any wire harness rub points? Do harnesses route over any sharp edges, corners, or brackets?

- **Is a service tool connector installed in close proximity to the engine? Is it accessible?**

- If the machine is particularly large, or if the cab or operator station is a significant distance from the engine, the OEM customer may want to install additional service tool connectors on the machine.

- **SAE J1939 Data Link Wiring**

- Has shielded wiring been used?
- Is the shield connected?
- Are terminating resistors of the appropriate size installed on either end of the backbone?

A 9 Reference Media Numbers

For additional information, use the following publications:

- Pocket Guide, SEBD0402, "Guidelines for Routing and Installing Wire Harness Assemblies"
- Installation Guide, REHS1413, "Installation and Operation of the Caterpillar Messenger Driver Information Display"

C7 and C9 Industrial Engines:

- Operation and Maintenance Manual, SEBU8089, "C7 Industrial Engines"
- Operation and Maintenance Manual, SEBU7772, "C9 Industrial Engines"
- Troubleshooting, RENR2418, "C7 and C9 Industrial Engines"
- Electrical Schematic, RENR7933, "C7 Industrial Engines"
- Electrical Schematic, RENR7948, "C9 Industrial Engines"

C11 and C13 Industrial Engines:

- Operation and Maintenance Manual, SEBU7901, "C11 and C13 Industrial Engines"
- Troubleshooting, RENR5042, "C11, C13, C15, and C18 Industrial Engines"
- Electrical Schematic, RENR8045, "C11 and C13 Industrial Engines"

C15 and C18 Industrial Engines:

- Operation and Maintenance Manual, SEBU7902, "C15 Industrial Engines"
- Operation and Maintenance Manual, SEBU7899, "C18 Industrial Engines"
- Troubleshooting, RENR5042, "C11, C13, C15, and C18 Industrial Engines"
- Electrical Schematic, RENR8046, "C15 and C18 Industrial Engines"

C27 and C32 Industrial Engines:

- Troubleshooting, RENR9324, "C27 and C32 Industrial Engines"
- Operation and Maintenance Manual, SEBU8097, "C27 and C32 Industrial Engines"
- Electrical Schematic, KENR5072, "C27 and C32 Industrial Engines"

**Caterpillar.
Your Local Resource.
Worldwide.**

Your Cat dealer is prepared to answer any questions you may have about Cat Power Systems, customer support, parts or service capability anywhere in the world. For the name and number of the Cat dealer nearest you, visit our website or contact Caterpillar Inc. World Headquarters in Peoria, Illinois, U.S.A.

World Headquarters:

Caterpillar Inc.

Peoria, Illinois, U.S.A

Tel: (309) 578-6298

Fax: (309) 578-2559

Mailing Address:

Caterpillar Inc.

Industrial Power Systems

P.O. Box 610

Mossville, IL 61552

www.cat-industrial.com

E-mail: cat_power@cat.com

CATERPILLAR®

Materials and specifications are subject to change without notice.

Rating ranges listed include the lowest and highest available for a specific engine or family of engines. Load factor and time at rated load and speed will determine the best engine/rating match.

CAT, CATERPILLAR, their respective logos, ACERT, ADEM, HEUI, Pocket Tec, "Caterpillar Yellow" and the POWER EDGE trade dress, as well as corporate and product identity used herein, are trademarks of Caterpillar and may not be used without permission.

LEBH4623-01 (1-07)

©2007 Caterpillar
All rights reserved.