

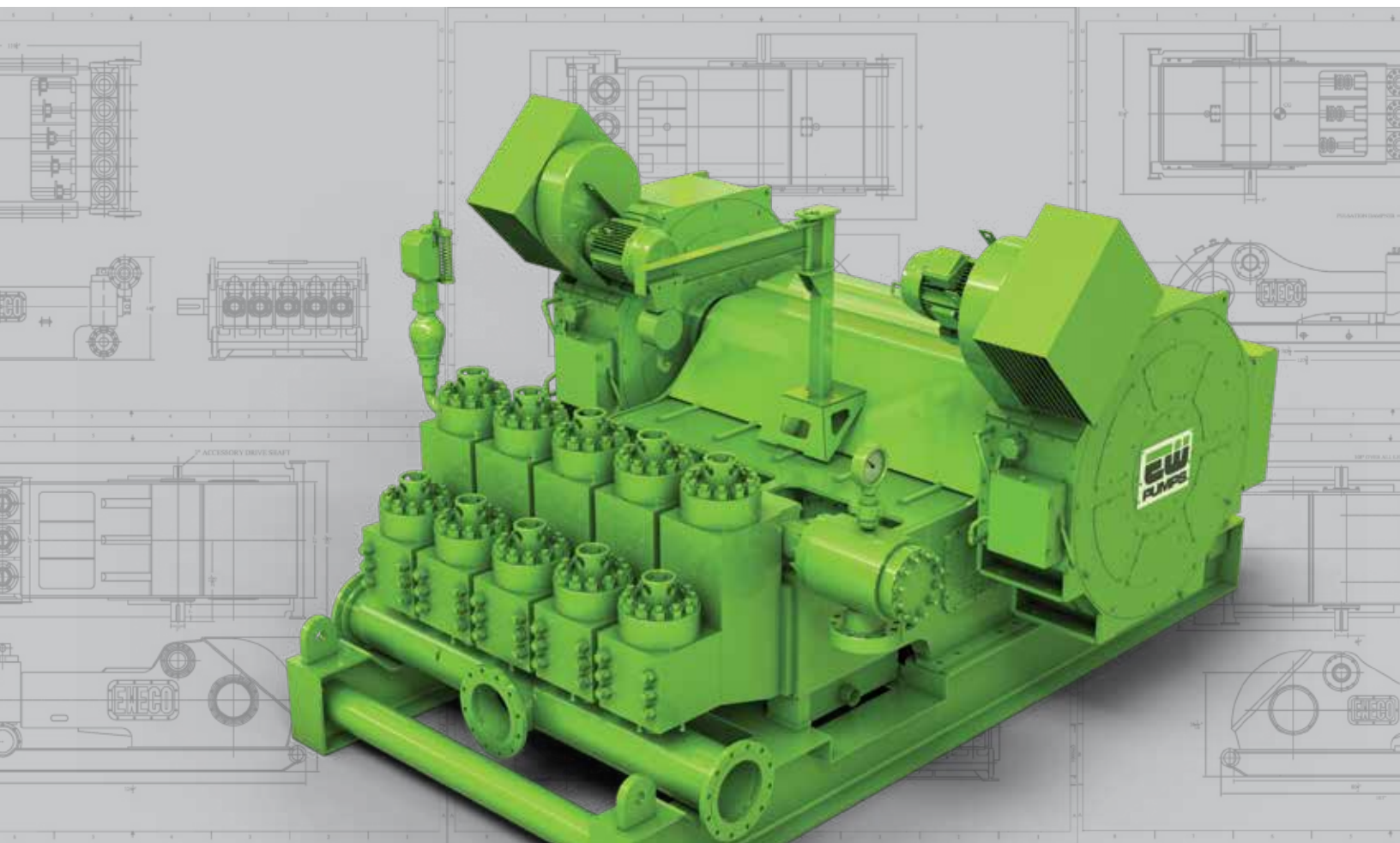

# Ellis-Williams™ Series Mud Pumps



## **EW Pumps**

8901 Gaylord Dr. Suite 200  
Houston, TX 77024  
+1-713-781-6885

**[EWpumps.com](http://EWpumps.com)**

# We Get It.

When your pumps aren't pumping,  
you aren't making money.



Our pedigreed, proprietary offering of Ellis-Williams pumps ranges from the E-447 Triplex to the high-performance EQ-2200 Quintuplex, (EQ-2400 specs available upon request). We have the pump you need at the terms you want. EW Pumps is proud to serve a variety of industries including oil & gas, HDD and mining. Each pump in our comprehensive lineup is built with reliability and performance at the core to make sure that you are successful.

We are here for you whether you need IRM (Inspection, Repair, and Maintenance) for your existing fleet, replacement parts, or if you need to upgrade to one of our pumps. We provide the deep expertise and timely response to keep your operations running smoothly.

## CONTENTS

<b>The Ellis-Williams Advantage</b>	<b>4</b>
<b>Quick Reference Product Guide</b>	<b>7</b>
<b>Single-Acting Quintuplex Pumps</b>	<b>8</b>
<b>EQ-2200</b> 12 in. Stroke Quintuplex Pump	<b>9</b>
<b>EQ-757</b> 7½ in. Stroke Quintuplex Pump	<b>10</b>
<b>Single-Acting Triplex Pumps</b>	<b>11</b>
<b>E-2200</b> 15 in. Stroke Triplex Pump	<b>12</b>
<b>EH-1600</b> 12 in. Stroke Triplex Pump	<b>13</b>
<b>E-1600</b> (7500 psi) 12 in. Stroke Triplex Pump	<b>14</b>
<b>E-1600</b> (5000 psi) 12 in. Stroke Triplex Pump	<b>15</b>
<b>E-1300</b> 10 in. Stroke Triplex Pump	<b>16</b>
<b>E-1100</b> 10 in. Stroke Triplex Pump	<b>17</b>
<b>E-800</b> 8½ in. Stroke Triplex Pump	<b>18</b>
<b>E-600</b> 8½ in. Stroke Triplex Pump	<b>19</b>
<b>E-447</b> 7 in. Stroke Triplex Pump	<b>20</b>
<b>IRM Services</b>	<b>21</b>
<b>Conversion Table</b>	<b>22</b>
<b>Equations</b>	<b>23</b>
<b>Contact Us</b>	<b>24</b>

### Worldwide Applications for Ellis-Williams Pumps

- Offshore drilling
- Land base drilling
- Well servicing/workover
- Water flood
- Cutting re-injection
- Saltwater disposal
- Cementing
- Crude oil transfer
- Hydraulic press water supply
- Horizontal directional drilling
- Water blast and jetting service
- Pressure maintenance
- Metering applications
- Coiled tubing drilling
- Riser boost services

## It's all about performance.

Our Ellis-Williams line comprises premium products featuring the latest technology.

- With their superior design, Ellis-Williams pumps have a longer life expectancy, and are able to work a lot harder, than the competition. All our pumps are rated for 24-hour-a-day, truly continuous duty.
- Our premium pumps are designed to deliver maximum performance with minimum weight at a total cost of ownership that makes sense.
- Higher horsepower pumps with a smaller footprint and lighter weight = reduced overall cost.

Regardless of the size or scope of your project, EW Pumps has the experience and resources to handle the job. At the same time, **you can count on us for fast, flexible and personal service.**

## The Ellis Williams Story

Ellis Williams began his life's work with mud pumps in 1942. Over the next 30 years, Ellis pioneered single-acting, triplex pumps for oilfield drilling while working for Brewster (the Skytop Brewster triplex pumps). Ellis Williams also left his mark on the IDECO and EMSCO mud pump companies. By the 1970s, most pumps in the industry were designed by Ellis Williams. Clearly, he was ready to design and build superior mud pumps under his own banner. And thus, in 1974, the Ellis-Williams Company (EWCO) was born. The Ellis-Williams Engineering Company (EWECO) soon arrived on the scene.

For more than 30 years, the name Ellis Williams was synonymous with efficient, innovative and extremely durable pumps. Ellis Williams originated the use of roller bearings in all bearing locations, fully welded eccentric crankshafts and internal gears for inherently improved balance. Ellis also wrote AGMA Standard (424.01) Practice for Helical and Herringbone

Gearing for Oilfield Mud Pumps. The company became known for designing and building drilling pumps without comparison in the industry.

Weatherford acquired Ellis-Williams in 2008, aiming to leverage Ellis-Williams' years of experience and the tradition of full-service engineering for pumps and pump packages.

As dynamic and rewarding as the Ellis-Williams history has been so far, the most exciting chapters lie ahead. EW Pumps is a privately held company that purchased all of the assets and IP of the Ellis-Williams Pump product line from Weatherford in 2020. The three principles of EW Pumps all are stakeholders in the business and experienced in all aspects of the oilfield service & equipment (OFSE) business, specifically the drilling segment.

Ellis Williams wrote the book on mud pumps — and a new chapter is being written today by EW Pumps.

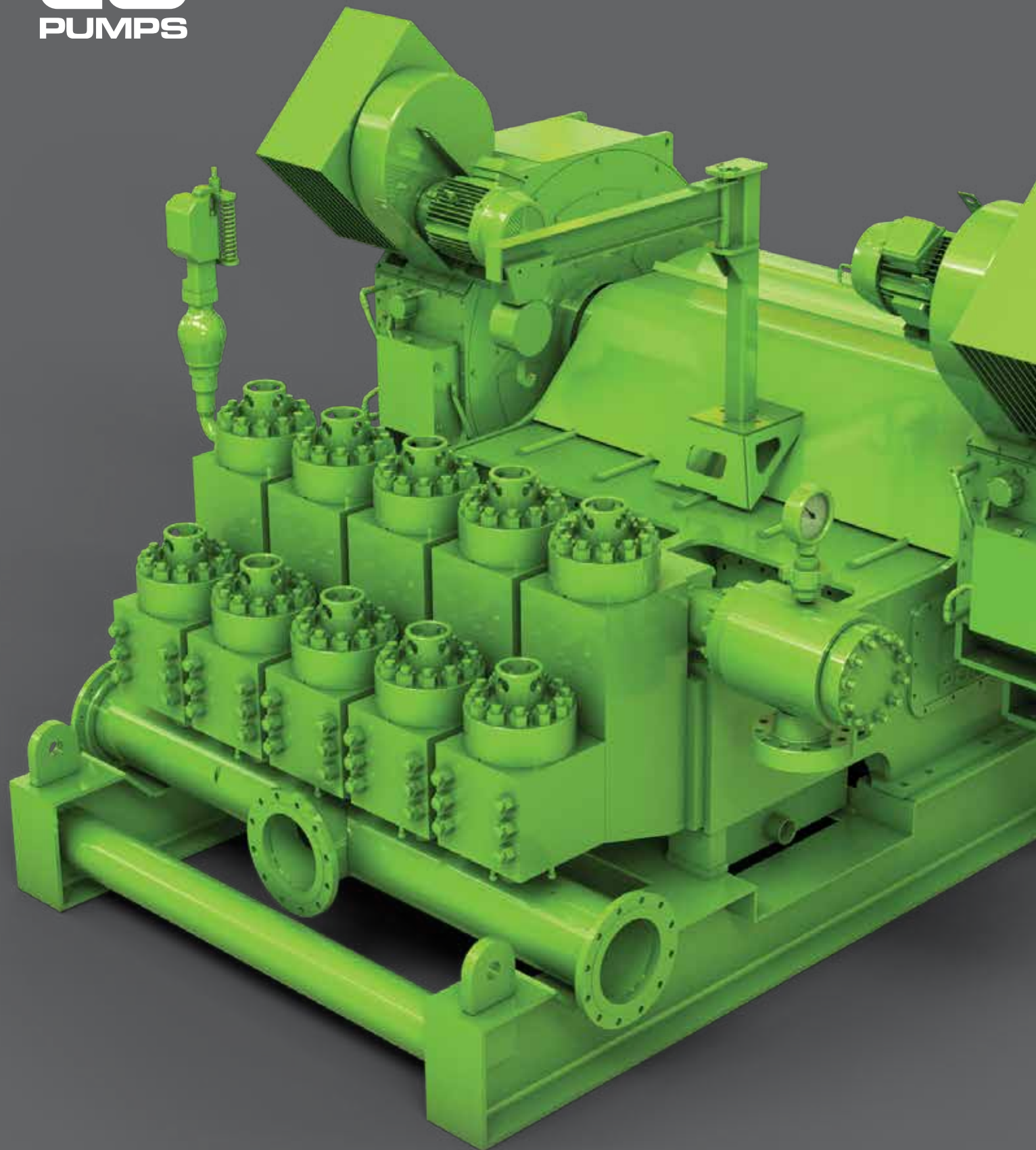

## Quick Reference Product Guide

Pump Type	Pump Model	Diameter and Stroke (in. x in.)	Nominal Maximum Power (HP/kW)	Maximum Pressure (psi/Mpa)	Maximum Flow (gal/min. l/min)	Maximum Speed (RPM)
Single-Acting Quintuplex	EQ-2200	7½ X 12 <sup>(1)</sup>	2,239 1,671	7,500 51.7	1,549 5,863	135
	EQ-757	6½ X 7½ <sup>(2)</sup>	830 619	5,000 34.5	1,185 4,486	220
Single-Acting Triplex	E-2200	9 X 15 <sup>(3)</sup>	2,200 1,641	7,500 51.7	1,301 4,925	105
	EH-1600	7½ X 12 <sup>(4)</sup>	1,627 1,214		929 3,517	135
	E-1600 <sup>(5)</sup> (L-Shaped DM)	7¼ X 12	1,689 1,260		772 2,922	120
	E-1600 <sup>(5)</sup> (V-O-V DM)	7 X 12	1,575 1,175	5,000 34.5	720 2,725	120
	E-1300	7 X 12	1,353 1,009		720 2,725	120
	E-1100	7 X 10	1,115 832		675 2,555	135
	E-800	7 X 8½	847 632		637 2,411	150
	E-600	7 X 8½	632 472		574 2,173	135
	E-447	6½ X 7 <sup>(6)</sup>	440 328		664 2,514	220

**Notes:**

- (1) EQ-2200 - 7½" liner is a special order induction hardened item.
- (2) EQ-757 - 6½" liner is a special order induction hardened item and requires a custom liner retainer.
- (3) E-2200 - 9" liner is a special order induction hardened item and requires a custom liner retainer.
- (4) EH-1600 - 7½" liner is a special order induction hardened item.
- (5) E-1600 is available in a 5000 psi (Valve-Over-Valve) version and a 7500 psi (Two Piece L-Shaped Discharge Manifold) version.
- (6) E-447 - 6½" liner is a special order induction hardened item and requires a custom liner retainer.

# Quintuplex Pumps



EW Pumps' Ellis-Williams patented quintuplex pumps represents the next true evolution of the modern mud pump since the introduction of the single-acting triplex mud pump over 50 years ago. Our EQ Series pumps incorporate the latest in pump-engineering technology, providing the industry with features and benefits not available from existing triplex pumps.

## The Quintuplex Advantage

Suitable for land and offshore drilling, HDD and a range of other applications, the premium Ellis-Williams™ EQ series pumps offer the smoothest, quietest operation of any mud pump in the industry. Featuring a smaller footprint and higher maximum flow rates than traditional triplex pump designs in the same horsepower class, EQ Series pumps improve flow rates by up to 40%. This reduces the number of pumps and total power draw required, leading to CAPEX and ESG benefits for end users.

The single-acting triplex mud pump, that is still the industry standard today, imparts high pressure pulsations into the discharge mud stream as a result of the flow variations generated by the action of three cylinders pumping at 120° increments around the crankshaft. This results in a total flow variation of 23 percent; 6 percent above and 17 percent below the average or mean flow rate. End users have historically used large and expensive pulsation dampening equipment to mitigate these pulsations, which can cause excessive vibration leading to metal fatigue and frequent repair. These pulsations also affect the performance of telemetry systems, requiring complex software algorithms to filter and condition the signal.

With a five-piston system, EQ Series pumps reduce hydraulic 'noise' through pulsation by 25 to 70%. The five-cylinder quintuplex pump delivers smooth output flow by design. Total flow variation is only 7 percent of the average on a quintuplex pump vs. 23 percent on a conventional triplex pump. This translates into a significant drop in mud pressure pulsations created by the pump that are directly transmitted to the pump components, discharge piping, and ultimately the drill string itself. This dramatically reduces the reliance on pulsation dampeners and filtering software to achieve efficient operations and telemetry.

While the basic design and low pulsation advantages of a quintuplex pump have been known for years, the Ellis-Williams EQ Series pumps are the only quintuplex pumps offering internal herringbone gear reduction and full roller-bearing construction throughout, just like the proven triplex pump. In fact, the most significant advantage of the quintuplex pump is its simplicity. It provides all of the advantages highlighted above through the same proven and reliable components used in many of our mature triplex models.

All drawings on the following pages are illustrative only. Final design, dimensions and weights will be confirmed on order.

# EQ-2200

## High-Performance 12 in. Stroke Quintuplex Pump

Piston Size (in.)	Discharge Pressure Rating (psi/Mpa)	Output (gal/rev. l/rev)	Output (gal/min, l/min)					
			Strokes/min (spm)	135	120	110	100	80
7½ <sup>(1)</sup>	2,230	11.475	1,549	1,377	1,262	1,148	918	689
	15.4	43.438	5,863	5,213	4,777	4,346	3,475	2,608
7	2,560	9.996	1,349	1,200	1,100	1,000	800	600
	17.7	37.839	5,106	4,542	4,164	3,785	3,028	2,271
6½	2,975	8.619	1,164	1,034	948	862	690	517
	20.5	32.626	4,406	3,914	3,589	3,263	2,612	1,957
6	3,475	7.344	991	881	808	734	588	441
	24.0	27.800	3,751	3,335	3,059	2,778	2,226	1,669
5½	4,125	6.171	833	741	679	617	494	370
	28.6	23.360	3,153	2,805	2,570	2,336	1,870	1,401
5	5,000	5.100	688	612	561	510	408	306
	34.5	19.306	2,604	2,317	2,124	1,931	1,544	1,158
4½	6,200	4.131	558	496	454	413	330	248
	42.7	15.638	2,112	1,878	1,719	1,563	1,249	939
4	7,500	3.264	441	392	359	326	261	196
	51.7	12.356	1,669	1,484	1,359	1,234	988	742

All output calculations are based on 95% mechanical efficiency and 100% volumetric efficiency.

(1) EQ-2200 – 7½" liner is a special order induction hardened item.

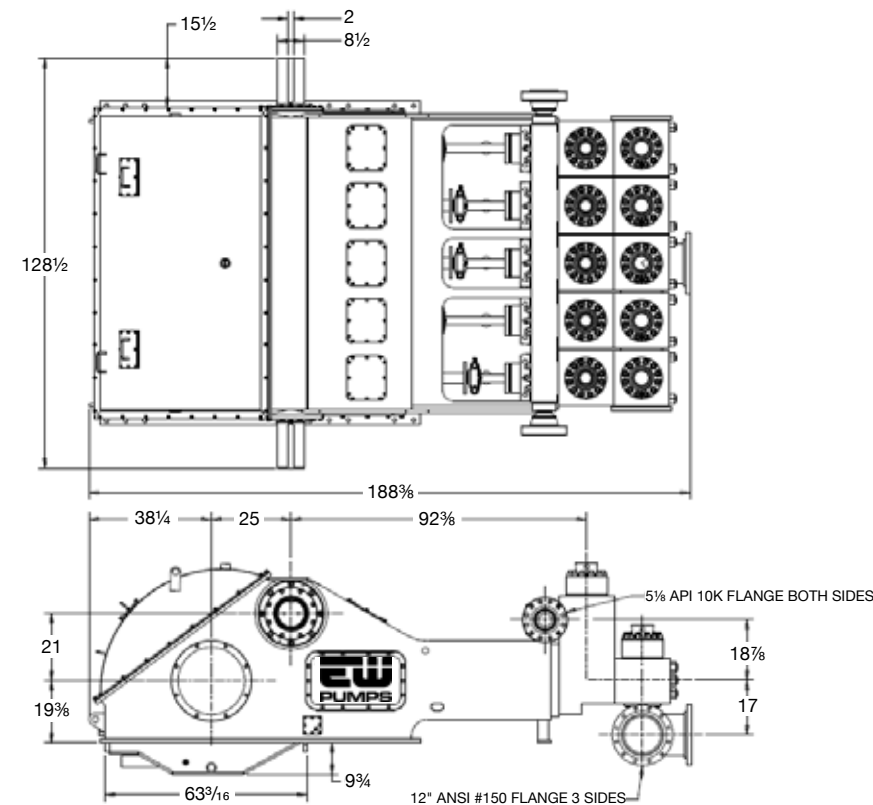

Rated Input Power (HP/kW)	2,239 1,671
Maximum Pump Speed (spm)	135
Stroke Length (in./mm)	12 304.8
Maximum Piston Size (in.)	7½
Fluid-End Pressure Rating (psi/MPa)	7,500 51.7
Fluid-End Style	Ellis-Williams
Valve Size	API-6M
Suction Connection	12 in. Flanged
Discharge Connection	5½ in. Flanged
Gear Ratio	4.43:1
Crankcase Oil Capacity (gal/l)	230 871
Liner Wash Capacity (gal/l)	180 681
Input Shaft Diameter (in./mm)	8.5 215.9
Pump Weight, Less Skid (lb/kg)	74,400 34,020

Piston Size (in.)	Discharge Pressure Rating (psi/Mpa)	Output (gal/rev. l/rev)	Output (gal/min, l/min)					
			220	200	180	150	120	100
6½ <sup>(2)</sup>	1,080	5.387	1,185	1,077	970	808	646	539
	7.4	20.392	4,486	4,077	3,672	3,059	2,445	2,040
6	1,275	4.590	1,010	918	826	689	551	459
	8.8	17.375	3,823	3,475	3,127	2,608	2,086	1,738
5½	1,500	3.857	849	771	694	579	463	386
	10.3	14.600	3,214	2,919	2,627	2,192	1,753	1,461
5	1,825	3.188	701	637	574	478	383	319
	12.6	12.068	2,654	2,411	2,173	1,809	1,450	1,208
4	3,725	2.040	449	408	367	306	245	204
	25.7	7.722	1,700	1,544	1,389	1,158	927	772
3	5,000	1.148	252	229	207	172	138	115
	34.5	4.346	954	867	784	651	522	435

All output calculations are based on 95% mechanical efficiency and 100% volumetric efficiency.

(2) EQ-757 - 6½" liner is a special order induction hardened item and requires a custom liner retainer.

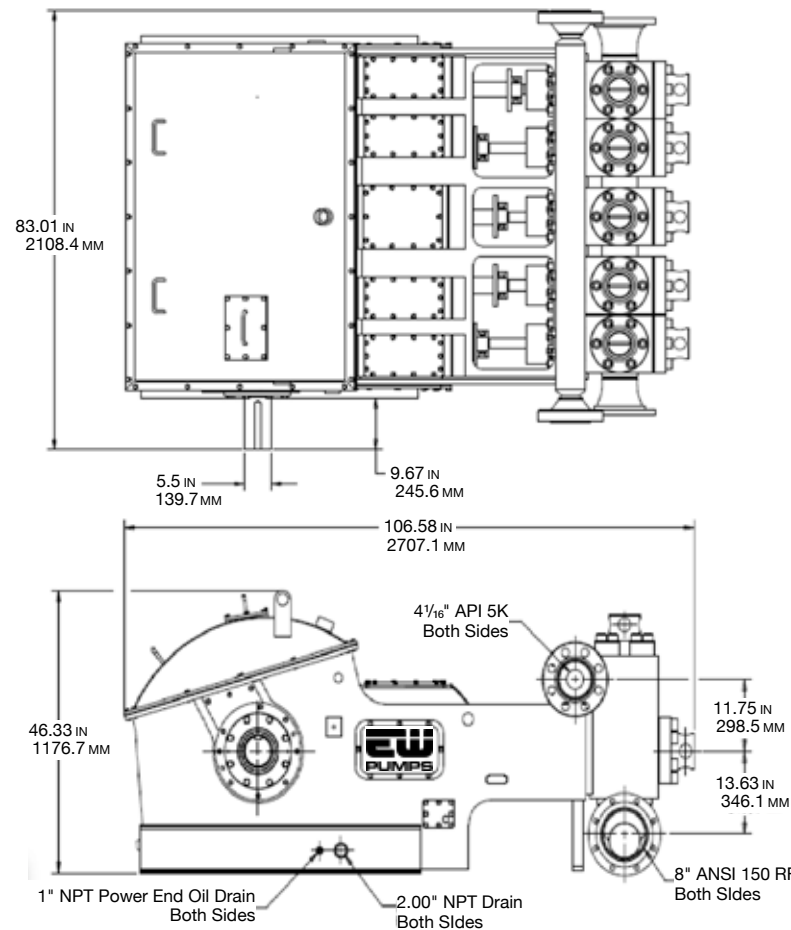

Rated Input Power (HP/kW)	830 619
Maximum Pump Speed (spm)	220
Stroke Length (in./mm)	7.5 190.5
Maximum Piston Size (in.)	6½
Fluid-End Pressure Rating (psi/MPa)	5,000 34.5
Fluid-End Style	Ellis-Williams
Valve Size	API-5
Suction Connection	8 in. Flanged
Discharge Connection	4 1/16 in. Flanged
Crankcase Oil Capacity (gal/l)	55 208
Liner Wash Capacity (gal/l)	40 151
Input Shaft Diameter (in./mm)	5.5 139.7
Pump Weight, Less Skid (lb/kg)	14,000 6,350

# Triplex Pumps

Each Ellis-Williams triplex pump is engineered from the ground up to provide you with continuous, reliable operation you can depend on. From the high-horsepower E-2200 to the handy and compact E-447, our line of triplex pumps comprises a broad range of power, pressure, flow rate, speed, and size specifications. This comprehensive portfolio gives you confidence that we have a triplex pump to fit your specific project scope and objectives.

## The Triplex Advantage

EW Pumps' Ellis-Williams patented triplex piston pumps are built with reliability at the core. Their superior design is backed by our engineering and OEM knowledge, resulting in tried-and-true pumps that last longer and work harder than the competition.

Compared with quintuplex pumps, triplex pumps offer a few distinct advantages. In terms of design, triplex pumps utilize three pistons instead of five, and thus have fewer internal parts and moving components. This simplicity in engineering facilitates easier inspection, repair, and maintenance; of huge importance if you're operating in a remote location or simply want reliable performance without requiring dedicated monthly maintenance. Fewer internal parts also mean a decreased footprint and overall weight; in fact, our EH-1600 mud pump is so light that you can transport it on roads and bridges at any time, day or night, without requiring special load permits.

Additionally, some of our triplex pumps use the same fluid ends and mechanisms as our quintuplex pumps. As a result, your spares investment and resupply stock are much less because the expendables work in either pump.

Built for extreme durability, our triplex pumps feature all-steel construction; an inherently balanced crankshaft design; internal herringbone gear reduction; and full roller-bearing construction throughout. Bearings are designed to API Spec 7K with an L10 life of 20,000 hours with proper lubrication and maintenance.

Regardless of the size or scope of your project, EW Pumps has the triplex pump to handle the job while providing the fast, flexible, and personalized service to keep your operations running smoothly.

All drawings on the following pages are illustrative only. Final design, dimensions and weights will be confirmed on order.

# E-2200

## High-Performance 15 in. Stroke Triplex Pump

Piston Size (in.)	Discharge Pressure Rating (psi/Mpa)	Output (gal/rev. l/rev)	Output (gal/min, l/min)					
			105	100	90	80	70	60
9 <sup>(3)</sup>	2,628	12.393	1,301	1,239	1,115	991	868	744
	18.1	46.913	4,925	4,690	4,221	3,751	3,286	2,816
8½	2,946	11.054	1,161	1,105	995	884	774	663
	20.3	41.844	4,395	4,183	3,766	3,346	2,930	2,510
8	3,326	9.792	1,028	979	881	783	685	588
	22.9	37.067	3,891	3,706	3,335	2,964	2,593	2,226
7½	3,784	8.606	904	861	775	689	602	516
	20.1	32.577	3,422	3,259	2,934	2,608	2,279	1,953
7	4,344	7.497	787	750	675	600	525	450
	30.0	28.379	2,979	2,839	2,555	2,271	1,987	1,703
6½	5,038	6.464	679	646	582	517	452	388
	34.7	24.469	2,570	2,445	2,203	1,957	1,711	1,469
6	5,912	5.508	575	551	496	441	386	330
	40.8	20.850	2,177	2,086	1,878	1,669	1,461	1,249
5½	7,036	4.628	486	463	417	370	324	278
	48.5	17.519	1,840	1,753	1,579	1,401	1,226	1,052
5	7,500	3.825	402	382	344	306	268	230
	51.7	14.479	1,522	1,446	1,302	1,158	1,014	871

All output calculations are based on 95% mechanical efficiency and 100% volumetric efficiency.

(3) E-2200 – 9" liner is a special order induction hardened item and requires a custom liner retainer.

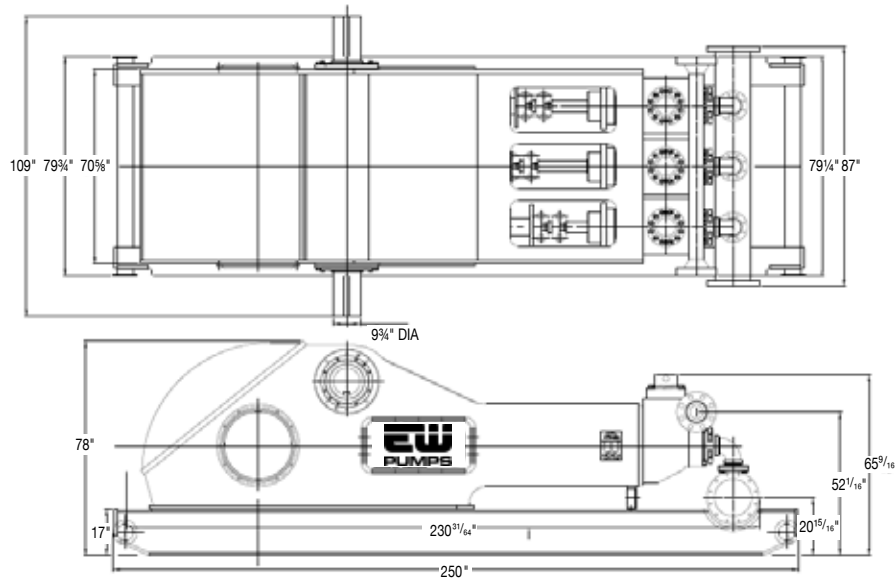

Rated Input Power (HP/kW)	2,200 1,641
Maximum Pump Speed (spm)	105
Stroke Length (in./mm)	15 381.0
Maximum Piston Size (in.)	9
Fluid-End Pressure Rating (psi/MPa)	7,500 51.7
Fluid-End Style	Ellis-Williams
Valve Size	API-7M
Suction Connection	12 in. Flanged
Discharge Connection	5 in. Flanged
Gear Ratio	4.85:1
Crankcase Oil Capacity (gal/l)	210 795
Liner Wash Capacity (gal/l)	170 644
Input Shaft Diameter (in./mm)	9.75 247.7
Pump Weight, Less Skid (lb/kg)	82,490 37,417

# EH-1600

## High-Performance 12 in. Stroke Triplex Pump

Piston Size (in.)	Discharge Pressure Rating (psi/Mpa)	Output (gal/rev. l/rev)	Output (gal/min, l/min)					
			135	130	120	100	80	60
7½ <sup>(4)</sup>	2,703	6.885	929	895	826	689	551	413
	18.6	26.063	3,517	3,388	3,127	2,608	2,086	1,563
7	3,103	5.998	810	780	720	600	480	360
	21.4	22.705	3,066	2,953	2,725	2,271	1,817	1,363
6½	3,598	5.171	698	672	621	517	414	310
	24.8	19.574	2,642	2,544	2,351	1,957	1,567	1,173
6	4,223	4.406	595	573	529	441	353	264
	29.1	16.679	2,252	5,169	2,002	1,669	1,336	999
5½	5,000	3.703	500	481	444	370	296	222
	34.5	14.029	1,893	1,821	1,681	1,401	1,120	840
5	5,000	3.060	413	398	367	306	245	184
	34.5	11.583	1,563	1,507	1,389	1,158	927	697

All output calculations are based on 95% mechanical efficiency and 100% volumetric efficiency.

(4) EH-1600 – 7½" liner is a special order induction hardened item.

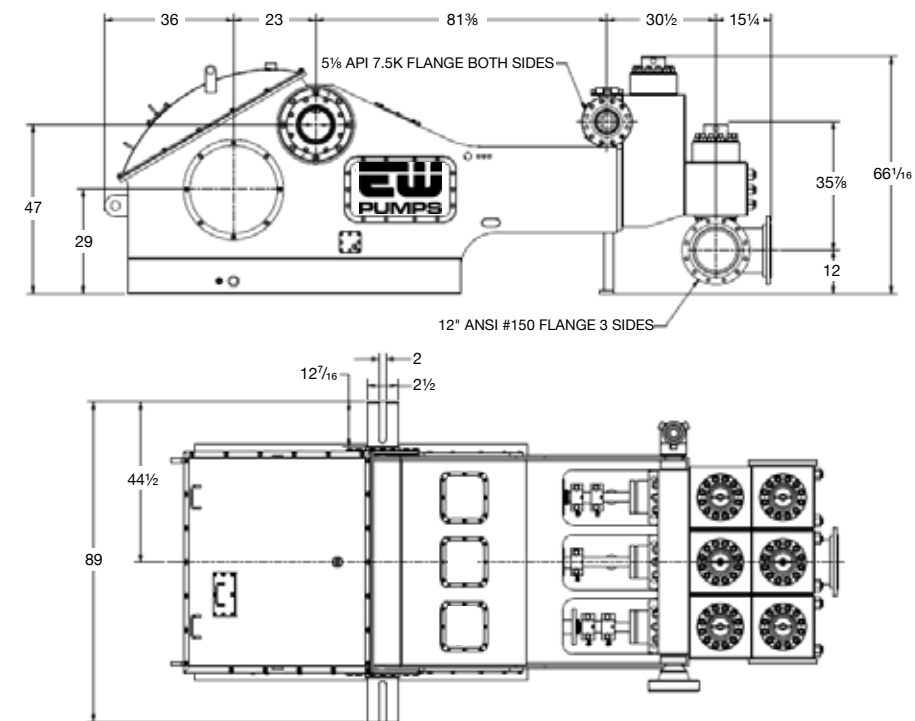

Rated Input Power (HP/kW)	1,627 1,214
Maximum Pump Speed (spm)	135
Stroke Length (in./mm)	12 304.8
Maximum Piston Size (in.)	7½
Fluid-End Pressure Rating (psi/MPa)	7,500 51.7
Fluid-End Style	Ellis-Williams
Valve Size	API-6M
Suction Connection	12 in. Flanged
Discharge Connection	5½ in. Flanged
Gear Ratio	4.21:1
Crankcase Oil Capacity (gal/l)	185 700
Liner Wash Capacity (gal/l)	110 416
Input Shaft Diameter (in./mm)	8.5 215.9
Pump Weight, Less Skid (lb/kg)	43,000 19,504

# E-1600 (7500 psi)

## High-Performance 12 in. Stroke Triplex Pump

Piston Size (in.)	Discharge Pressure Rating (psi/Mpa)	Output (gal/rev. l/rev)	Output (gal/min, l/min)					
			120	110	100	90	70	50
7 1/4	3,375	6.434	772	708	643	579	450	332
	23.3	24.355	2,922	2,680	2,434	2,192	1,704	1,219
7	3,620	5.998	720	660	600	540	420	300
	24.959	22.705	2,725	2,498	2,271	2,044	1,590	1,136
6 1/2	4,198	5.171	621	569	517	465	362	259
	28.944	19.574	2,351	2,154	1,957	1,760	1,370	980
6	4,927	4.406	529	485	441	397	308	220
	33.970	16.679	2,002	1,836	1,669	1,503	1,166	833
5 1/2	5,000	3.703	444	407	370	333	259	185
	34.474	14.017	1,681	1,541	1,401	1,261	980	700
5	5,000	3.060	367	337	306	275	214	153
	34.474	11.583	1,389	1,276	1,158	1,041	810	579
4 3/4	7,500	2.762	331	304	276	249	193	138
	51.7	10.455	1,253	1,151	1,045	943	731	522

All output calculations are based on 95% mechanical efficiency and 100% volumetric efficiency.

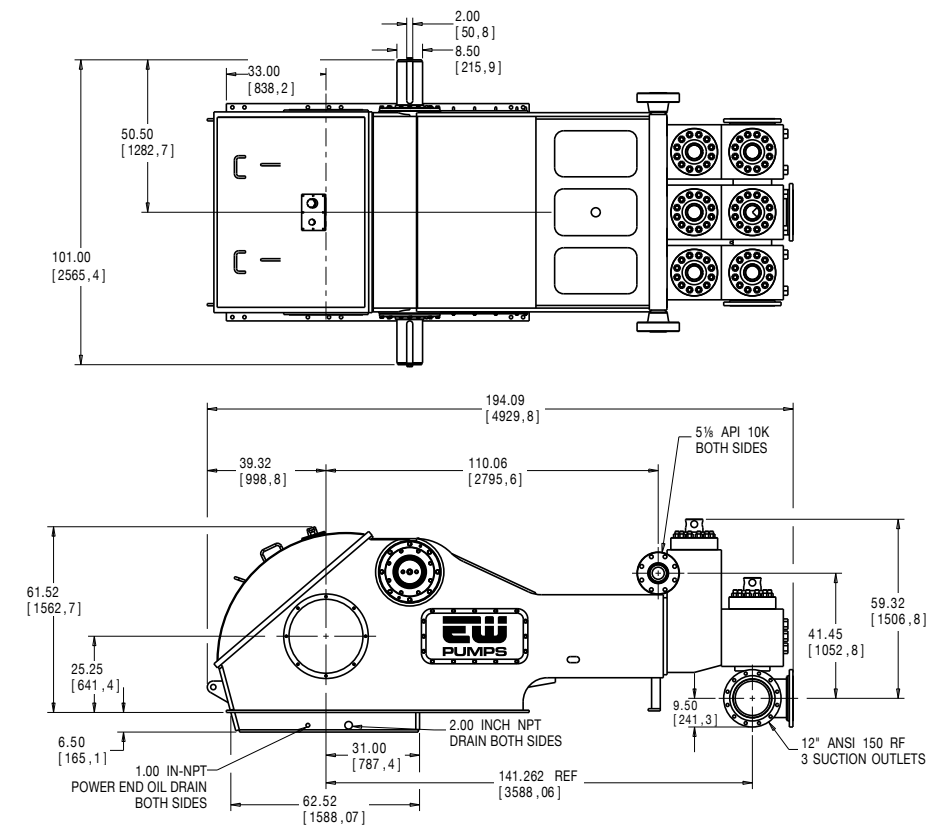

Rated Input Power (HP/kW)	1,689 1,260
Maximum Pump Speed (spm)	120
Stroke Length (in./mm)	12 304.8
Maximum Piston Size (in.)	7 1/4
Fluid-End Pressure Rating (psi/MPa)	7,500 51.7
Fluid-End Style	FC-1600
Valve Size	API-6M
Suction Connection	12 in. Flanged
Discharge Connection	5 1/8 in. Flanged
Gear Ratio	4.47:1
Crankcase Oil Capacity (gal/l)	185 700
Liner Wash Capacity (gal/l)	110 416
Input Shaft Diameter (in./mm)	8.5 215.9
Pump Weight, Less Skid (lb/kg)	64,000 29,030

# E-1600 (5000 psi)

## High-Performance 12 in. Stroke Triplex Pump

Piston Size (in.)	Discharge Pressure Rating (psi/Mpa)	Output (gal/rev. l/rev)	Output (gal/min, l/min)					
			120	110	100	90	70	50
7	3,620	5.998	720	660	600	540	420	300
	25.0	22.705	2,725	2,498	2,271	2,044	1,590	1,136
6 1/2	4,198	5.171	621	569	517	465	362	259
	28.9	19.574	2,351	2,154	1,957	1,760	1,370	980
6	4,927	4.406	529	485	441	397	308	220
	34.0	16.679	2,002	1,836	1,669	1,503	1,166	833
5 1/2	5,000	3.703	444	407	370	333	259	185
	34.5	14.017	1,681	1,541	1,401	1,261	980	700
5	5,000	3.060	367	337	306	275	214	153
	34.5	11.583	1,389	1,276	1,158	1,041	810	579
4 1/2	5,000	2.479	297	273	248	223	174	124
	34.5	9.484	1,124	1,033	939	844	659	469
4	5,000	1.958	235	215	196	176	137	98
	34.5	7.412	890	814	742	665	519	371

All output calculations are based on 95% mechanical efficiency and 100% volumetric efficiency.

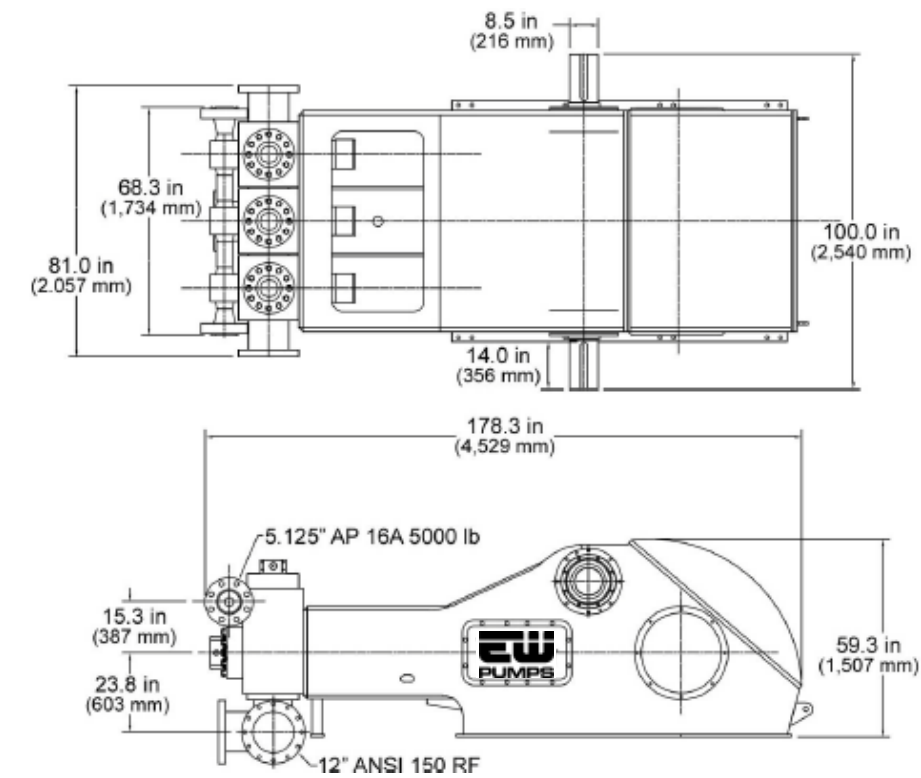

Rated Input Power (HP/kW)	1,575 1,175
Maximum Pump Speed (spm)	120
Stroke Length (in./mm)	12 304.8
Maximum Piston Size (in.)	7
Fluid-End Pressure Rating (psi/MPa)	5,000 34.5
Fluid-End Style	FB-1300/1600
Valve Size	API-7
Suction Connection	12 in. Flanged
Discharge Connection	5 1/8 in. Flanged
Gear Ratio	4.47:1
Crankcase Oil Capacity (gal/l)	185 700
Liner Wash Capacity (gal/l)	110 416
Input Shaft Diameter (in./mm)	8.5 215.9
Pump Weight, Less Skid (lb/kg)	58,500 26,535



# E-1300

## High-Performance 10 in. Stroke Triplex Pump

Piston Size (in.)	Discharge Pressure Rating (psi/Mpa)	Output (gal/rev. l/rev)	Output (gal/min, l/min)					
			120	110	100	90	70	50
7	2,900	5.998	720	660	600	540	420	300
	20.0	22.705	2,725	2,498	2,271	2,044	1,590	1,136
6½	3,400	5.171	621	569	517	465	362	259
	23.4	19.574	2,351	2,154	1,957	1,760	1,370	980
6	4,000	4.406	529	485	441	397	308	220
	27.6	16.679	2,002	1,836	1,669	1,503	1,166	833
5½	5,000	3.703	444	407	370	333	259	185
	34.5	14.017	1,681	1,541	1,401	1,261	980	700
5	5,000	3.060	367	337	306	275	214	153
	34.5	11.583	1,389	1,276	1,158	1,041	810	579

All output calculations are based on 95% mechanical efficiency and 100% volumetric efficiency.

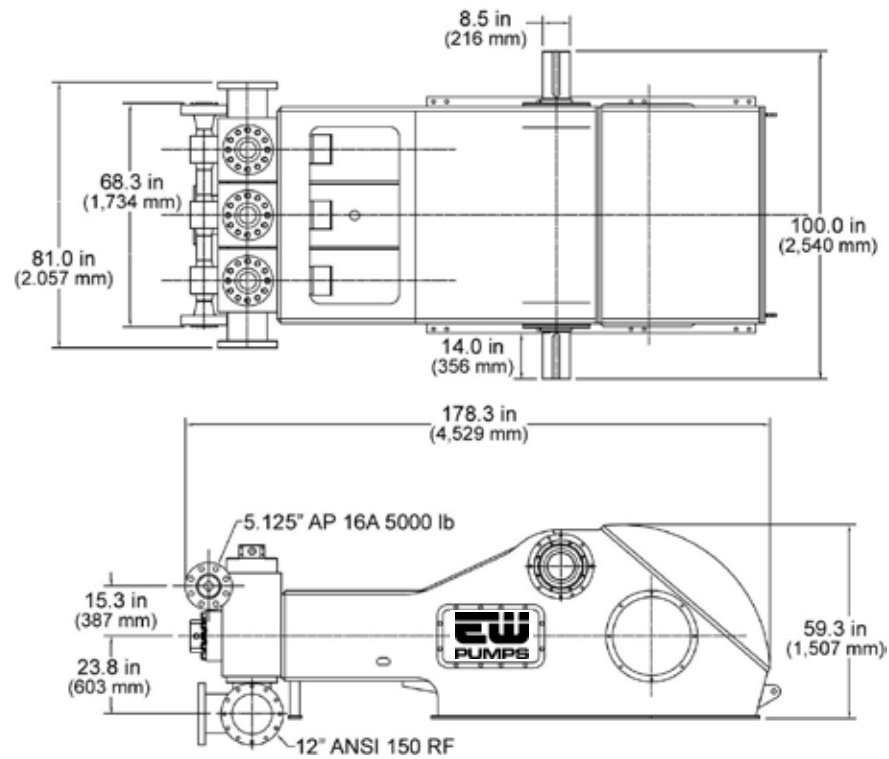

Rated Input Power (HP/kW)	1,353 1,009
Maximum Pump Speed (spm)	120
Stroke Length (in./mm)	12 304.8
Maximum Piston Size (in.)	7
Fluid-End Pressure Rating (psi/MPa)	5,000 34.5
Fluid-End Style	FB-1300/1600
Valve Size	API-7
Suction Connection	12 in. Flanged
Discharge Connection	5½ in. Flanged
Gear Ratio	4.47:1
Crankcase Oil Capacity (gal/l)	185 700
Liner Wash Capacity (gal/l)	110 416
Input Shaft Diameter (in./mm)	8.5 215.9
Pump Weight, Less Skid (lb/kg)	58,500 26,535

# E-1100

## High-Performance 10 in. Stroke Triplex Pump

Piston Size (in.)	Discharge Pressure Rating (psi/Mpa)	Output (gal/rev. l/rev)	Output (gal/min, l/min)					
			135	125	115	105	95	85
7	2,655	4.998	675	625	575	525	475	425
	18.3	18.919	2,555	2,366	2,177	1,987	1,798	1,609
6½	3,079	4.310	582	539	496	452	409	366
	21.2	16.315	2,203	2,040	1,878	1,711	1,548	1,385
6	3,613	3.672	496	459	422	386	349	312
	24.9	13.900	1,878	1,738	1,597	1,461	1,321	1,181
5½	4,300	3.086	417	386	355	324	293	262
	29.6	11.682	1,579	1,461	1,344	1,226	1,109	992
5	5,000	2.550	344	319	293	268	242	217
	34.5	9.653	1,302	1,208	1,109	1,014	916	821

All output calculations are based on 95% mechanical efficiency and 100% volumetric efficiency.

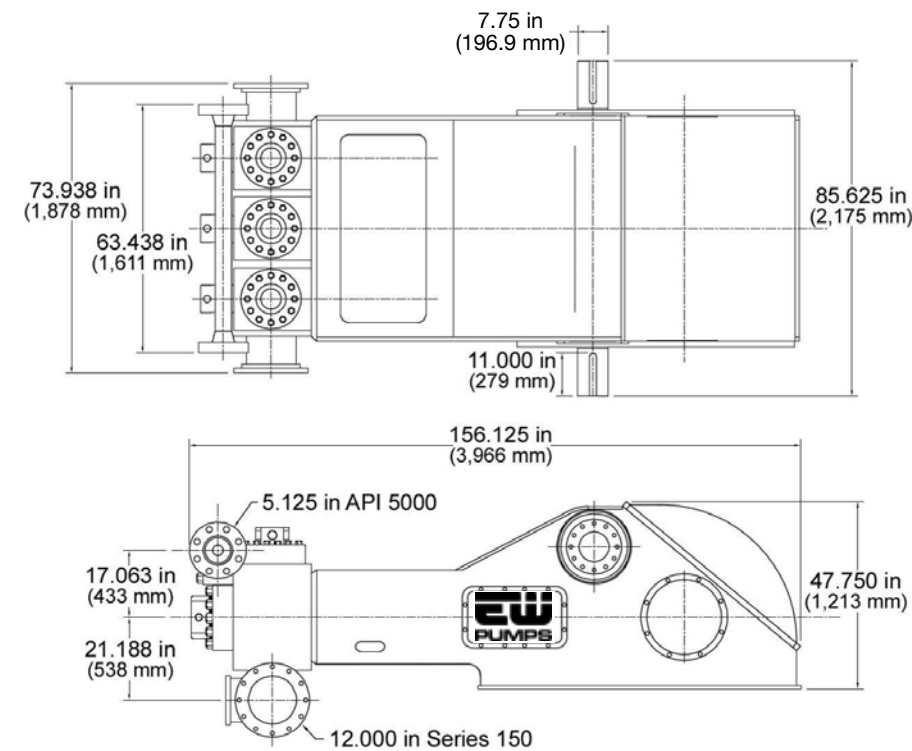

Rated Input Power (HP/kW)	1,115 832
Maximum Pump Speed (spm)	135
Stroke Length (in./mm)	10 254.0
Maximum Piston Size (in.)	7
Fluid-End Pressure Rating (psi/MPa)	5,000 34.5
Fluid-End Style	PZ-11
Valve Size	API-7
Suction Connection	12 in. Flanged
Discharge Connection	5½ in. Flanged
Gear Ratio	4.22:1
Crankcase Oil Capacity (gal/l)	110 416
Liner Wash Capacity (gal/l)	70 265
Input Shaft Diameter (in./mm)	7.75 196.9
Pump Weight, Less Skid (lb/kg)	28,700 13,018

# E-800

## High-Performance 8½ in. Stroke Triplex Pump

Piston Size (in.)	Discharge Pressure Rating (psi/Mpa)	Output (gal/rev. l/rev)	Output (gal/min, l/min)					
			150	130	120	100	80	50
7	2,050	4.248	637	552	510	425	340	212
	14.1	16.080	2,411	2,090	1,931	1,609	1,287	803
6½	2,375	3.663	549	476	440	366	293	183
	16.3	13.866	2,078	1,802	1,666	1,385	1,109	693
6	2,800	3.121	468	406	375	312	250	156
	19.2	11.814	1,772	1,537	1,420	1,181	946	591
5½	3,300	2.623	393	341	315	262	210	131
	22.8	9.929	1,488	1,291	1,192	992	795	496
5	4,000	2.168	325	282	260	217	173	108
	27.6	8.207	1,230	1,067	984	821	655	409
4½	5,000	1.756	263	228	211	176	140	88
	34.5	6.647	996	863	799	665	530	333
4	5,000	1.387	208	180	166	139	111	69
	34.5	5.250	787	681	628	526	420	261

All output calculations are based on 95% mechanical efficiency and 100% volumetric efficiency.

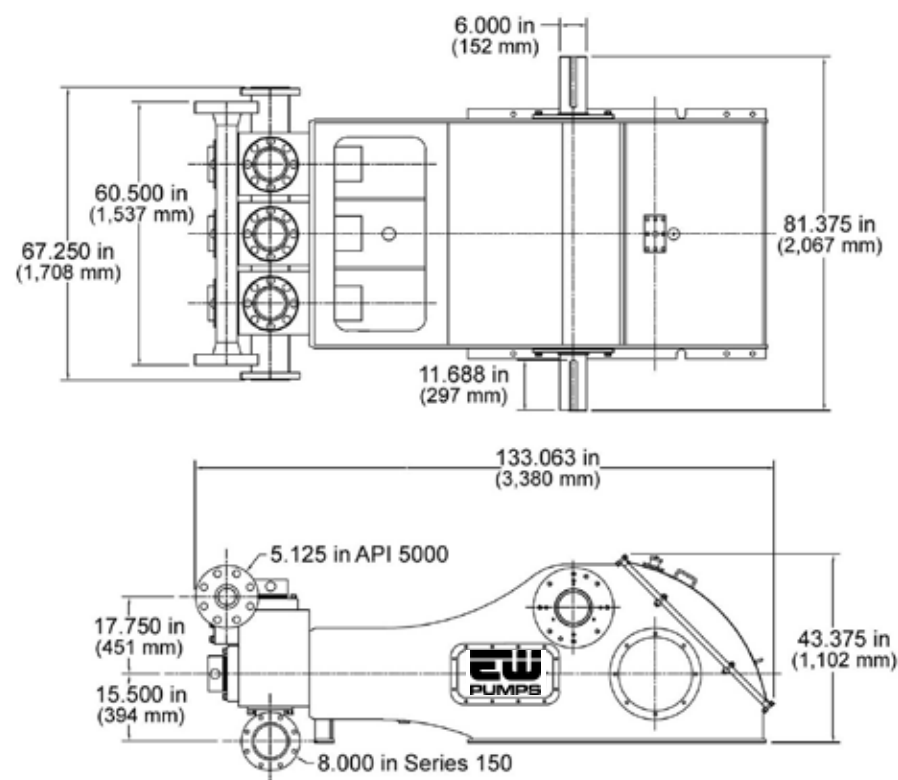

Rated Input Power (HP/kW)	847 632
Maximum Pump Speed (spm)	150
Stroke Length (in./mm)	8.5 215.9
Maximum Piston Size (in.)	7
Fluid-End Pressure Rating (psi/MPa)	5,000 34.5
Fluid-End Style	PZ-9
Valve Size	API-7
Suction Connection	8 in. Flanged
Discharge Connection	5½ in. - 5K Flanged
Gear Ratio	4.04:1
Crankcase Oil Capacity (gal/l)	55 208
Liner Wash Capacity (gal/l)	70 265
Input Shaft Diameter (in./mm)	6 152.4
Pump Weight, Less Skid (lb/kg)	22,500 10,206

# E-600

## High-Performance 8½ in. Stroke Triplex Pump

Piston Size (in.)	Discharge Pressure Rating (psi/Mpa)	Output (gal/rev. l/rev)	Output (gal/min, l/min)					
			135	125	115	105	95	80
7	1,700	4.248	574	531	489	446	404	340
	11.7	16.080	2,173	2,010	1,851	1,688	1,529	1,287
6	2,325	3.121	421	390	359	328	297	250
	16.0	11.814	1,594	1,476	1,359	1,242	1,124	946
5	2,775	2.168	293	271	249	228	206	173
	23.0	8.207	1,109	1,026	943	863	780	655
4½	4,125	1.756	237	219	202	184	167	140
	28.4	6.647	897	829	765	697	632	530
4	5,000	1.387	187	173	160	146	132	111
	34.5	5.250	708	655	606	553	500	420

All output calculations are based on 95% mechanical efficiency and 100% volumetric efficiency.

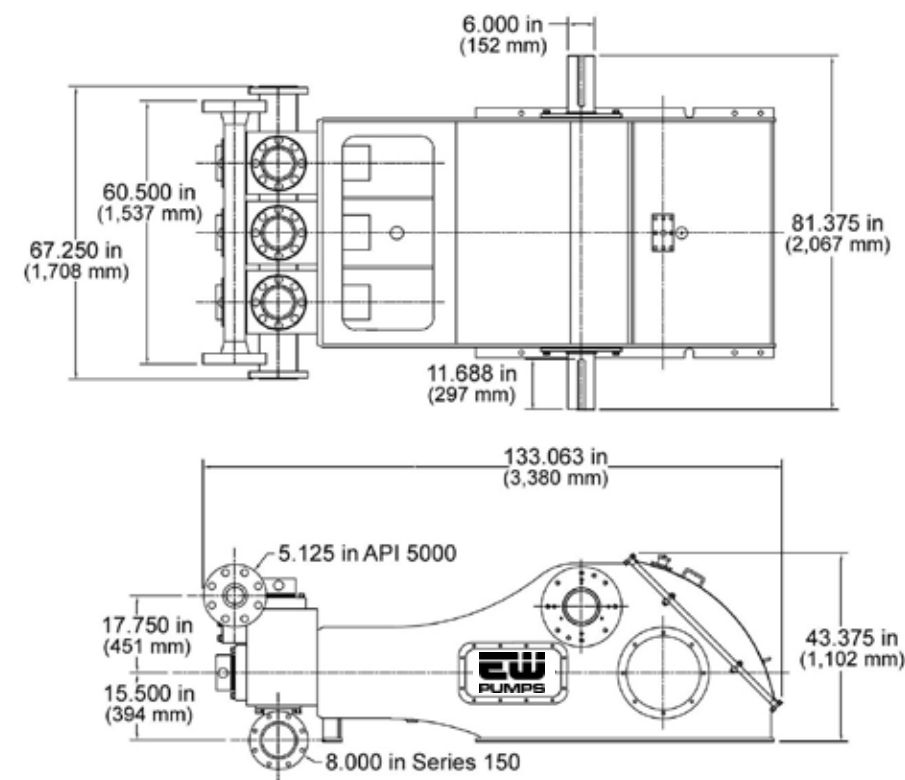

Rated Input Power (HP/kW)	632 472
Maximum Pump Speed (spm)	135
Stroke Length (in./mm)	8.5 215.9
Maximum Piston Size (in.)	7
Fluid-End Pressure Rating (psi/MPa)	5,000 34.5
Fluid-End Style	PZ-9
Valve Size	API-7
Suction Connection	8 in. Flanged
Discharge Connection	5½ in. - 5K Flanged
Gear Ratio	4.04:1
Crankcase Oil Capacity (gal/l)	55 208
Liner Wash Capacity (gal/l)	70 265
Input Shaft Diameter (in./mm)	6 152.4
Pump Weight, Less Skid (lb/kg)	18,500 8,391

Piston Size (in.)	Discharge Pressure Rating (psi/Mpa)	Output (gal/rev, l/rev)	Output (gal/min, l/min)					
			220	200	170	140	110	80
6½ <sup>6</sup>	1,080	3.017	664	603	513	422	332	241
	7.4	11.420	2,514	2,283	1,942	1,597	1,257	912
6	1,275	2.570	565	514	437	360	283	206
	8.8	9.729	2,139	1,946	1,654	1,363	1,071	780
5½	1,500	2.160	475	432	367	302	238	173
	10.4	8.176	1,798	1,635	1,389	1,143	901	655
5	1,825	1.785	393	357	303	250	196	143
	12.6	6.757	1,488	1,351	1,147	946	742	541
4½	2,250	1.446	318	289	260	202	145	101
	15.5	5.474	1,204	1,094	984	765	549	382
4	2,850	1.142	251	228	194	160	126	91
	19.7	4.323	950	863	734	606	477	344
3½	3,725	0.875	192	175	157	122	87	61
	25.7	3.312	727	662	594	462	329	231
3	5,000	0.643	141	129	109	90	71	51
	34.5	2.434	534	488	413	341	269	193

All output calculations are based on 95% mechanical efficiency and 100% volumetric efficiency.  
(6) E-447 – 6½" liner is a special order induction hardened item and requires a custom liner retainer.

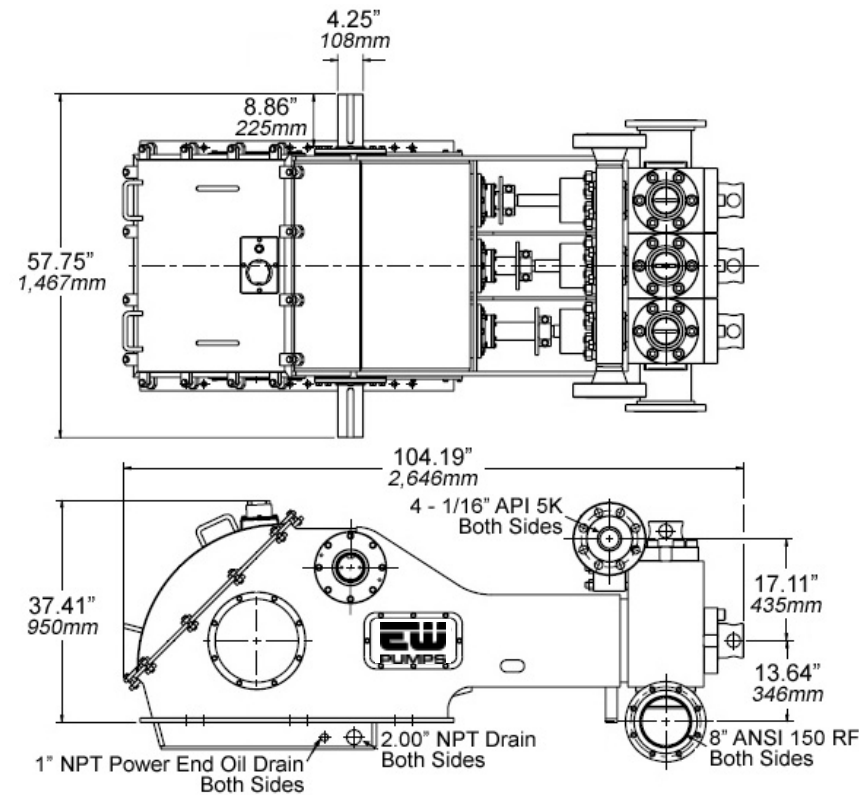

Rated Input Power (HP/kW)	440 328
Maximum Pump Speed (spm)	220
Stroke Length (in./mm)	7 177.8
Maximum Piston Size (in.)	6½
Fluid-End Pressure Rating (psi/MPa)	5,000 34.5
Fluid-End Style	Ellis-Williams
Valve Size	API-5
Suction Connection	8 in. Flanged
Discharge Connection	4½ in. Flanged
Gear Ratio	4.71:1
Crankcase Oil Capacity (gal/l)	40 151
Liner Wash Capacity (gal/l)	40 151
Input Shaft Diameter (in./mm)	4.25 108.0
Pump Weight, Less Skid (lb/kg)	13,000 5,897

# IRM Services



## Pump Inspection

The best way to maximize performance from your pumps is to maintain regular inspections. EW Pumps offers traditional in-shop/in-field inspections, as well as remote inspections for faster certifications while minimizing carbon emissions and HSE risk. Whether you're running an EW Pump or a third-party pump, we have the decades-gained experience, focused expertise, and local and global resources to fully inspect your equipment and maximize its efficiency. We can make sure you are aware of your pumps' condition whether they are in use or in your yard.

### Models Supported

E-447	EQ-757
E-600	EQ-2200
E-800	W-2215
E-1100	W-2214
E-1300	W-1712
E-1600	W-1714
EH-1600	W-446
E-2200	

For other pumps, please call us.



## Pump Repair

When something does go wrong with an onshore or offshore pump, you need fast response from your repair service provider to minimize downtime. You also need a well-designed pump that can be repaired or replaced at your operating site. EW Pumps is the OEM of our pump designs. We own the intellectual property and employ skilled workers who meticulously understand the operating nuances and unique capabilities of our pumps.

We also have the skilled technicians you need to perform expert repair on third-party pumps. Coupled with our agile management and operating structure, we have the local and global resources to deploy quickly, expedite repair and get your pumps — and profits — back online, before your service contract is jeopardized.



## Pump Maintenance

Timely and appropriate maintenance pays dividends for your pumps' service life and your bottom line. Pumps that are well-maintained are safer, more efficient, dependable, and help avoid costly, unanticipated repairs. Keep your equipment running optimally and reliably with EW Pumps' maintenance services. Our team of seasoned maintenance engineers have the technical experience and resources to deliver the scheduled servicing your pumps need to work at consistent, high-performance levels. Whether you're running our pumps or those from a third party, our experienced maintenance team and engineers can ensure more uptime for greater profitability.

# Conversion Table

Conversion Table		
To convert	Multiply by	To obtain
<b>Units of length</b>		
Inches	2.5400	centimeters
Feet	0.3048	meters
Miles	1.6093	kilometers
Kilometers	0.6214	miles
<b>Units of area</b>		
Square inches (in. <sup>2</sup> )	6.4516	square centimeters (cm <sup>2</sup> )
Square centimeters (cm <sup>2</sup> )	0.1550	square inches (in. <sup>2</sup> )
Square feet (ft <sup>2</sup> )	0.0929	square meters (m <sup>2</sup> )
Square meters (m <sup>2</sup> )	10.764	square feet (ft <sup>2</sup> )
<b>Units of volume</b>		
Gallons (U.S.)	3.7854	liters
Gallons (U.S.)	0.003785	cubic meters (m <sup>3</sup> )
Gallons (U.S.)	0.1337	cubic feet (ft <sup>3</sup> )
Cubic meters (m <sup>3</sup> )	264.172	gallons (U.S.)
Cubic feet (ft <sup>3</sup> )	28.317	liters
Cubic feet (ft <sup>3</sup> )	0.02832	cubic meters (m <sup>3</sup> )
Cubic feet (ft <sup>3</sup> )	7.48052	gallons (U.S.)
<b>Units of weight</b>		
Ounces	28.3495	grams
Pounds	453.59	grams
Pounds	0.4536	kilograms
Kilograms	2.2046	pounds
U.S. Tons (short)	907.18	kilograms
U.S. Tons (short)	2,000	pounds

Conversion Table		
To convert	Multiply by	To obtain
<b>Units of flow</b>		
GPM (U.S. gal/min)	0.2271	cubic meters/hours (m <sup>3</sup> /hr)
GPM (U.S. gal/min)	0.0631	liters/sec
GPM (U.S. gal/min)	34.280	BPD (42 US Gallon BBL)/day)
BPD (42 US Gallon BBL)/day)	0.00662	cubic meters/hours (m <sup>3</sup> /hr)
BPD (42 US Gallon BBL)/day)	0.00184	liters/sec
BPD (42 US Gallon BBL)/day)	0.02917	GPM (U.S. gal/min)
<b>Units of pressure</b>		
psi (lb/in <sup>2</sup> )	6.895	kPa (kilopascals)
psi (lb/in <sup>2</sup> )	0.070307	kg/cm <sup>2</sup>
kg/cm <sup>2</sup>	14.2233	psi (lb/in <sup>2</sup> )
Atmospheres	14.6959	psi (lb/in <sup>2</sup> )
Atmospheres	1.0332	kg/cm <sup>2</sup>
Feet of water (20°C)	0.03048	kg/cm <sup>2</sup>
Feet of water (20°C)	0.43353	psi (lb/in <sup>2</sup> )
Bar	1.0197	kg/cm <sup>2</sup>
Bar	14.504	psi (lb/in <sup>2</sup> )
<b>Units of power</b>		
Horsepower (HP)	1.014	metric horsepower
Horsepower (HP)	0.746	kilowatts (kW)
Kilowatts (kW)	1.34	horsepower (HP)
<b>Miscellaneous</b>		
Torque = [(HP)(5252)]/RPM		
Degrees Celsius (°C) = (F-32°)(5/9)		
Degrees Fahrenheit (°F) = (9/5)°C + 32°		
Belt length (pitch diameter pump sheave + pitch diameter driver)		

# Equations

Rod Load Calculation
Plunger load or piston load = $P_d \times \text{face area or piston or plunger}$
Horsepower Calculation, (input HP required at pump pinion shaft or crankshaft)
horsepower for single acting pump =
$\frac{(\text{GPM})(P_d)(100)}{(1714)(E_m)} - \frac{(\text{GPM})(P_s)(E_m - 5\%)}{(1714)(100)}$
horsepower for a double acting pump =
$\frac{(\text{GPM})(P_d - P_s)(100)}{(1714)(E_m)}$

## Nomenclature

$P_d$  = Pump Discharge Pressure, psi

$P_s$  = Pump Suction Pressure, psi

$E_m$  = Pump Mechanical Efficiency, in decimal form (e.g., 95% efficiency = 0.95)

GPM = U.S. gal/min

RPM = Crankshaft revolutions per minute



**EW Pumps**

8901 Gaylord Dr. Suite 200  
Houston, TX 77024

+1-713-781-6885

Solutions@EWPumps.com

If you would like more information about EW Pumps' superior Ellis-Williams pumps and pump packages visit our website at <https://EWPumps.com>

---

EW Pumps, LLC. products and services are subject to the Company's standard terms and conditions. For more information contact an authorized EW Pumps, LLC. representative. Unless noted otherwise, trademarks and service marks herein are the property of EW Pumps, LLC. Specifications are subject to change without notice. EW Pumps sells its products and services in accordance with the terms and conditions set forth in the applicable contract between EW Pumps, LLC. and the client.