

EM2510 with AMNC-F User Pre-installation Guide



Amada America Inc.
7025 Firestone Blvd.
Buena Park CA. 90621
Phone: (714) 739 2111
Fax.: (714) 739 4099
Email info@amada.com

Warning

- ❑ Qualified personnel must complete all work.
- ❑ Do not apply power to the EM2510 until an Amada Engineer is present and has instructed you to do so.
- ❑ Considerable effort has been made to ensure that this manual is free of inaccuracies and omissions. However, as we are constantly improving our product, some of the data contained herein may be out of date. Please check our Internet site, <http://www.amada.com>, for the latest release of this document.

Contents

Introduction.....	4
Motion Package Specifications.....	5
Punching System Specifications	5
AMNC-F Controller	6
Ram Control Features:	6
Electrical Requirements.....	7
Optional Equipment.....	7
Installing the Electrical Power Supply	8
Pneumatic Requirements	9
Optional Equipment.....	9
Installing the Air Supply.....	9
Planning the Location of the Machine	10
Moving the EM2510	10
Plan View – EM 2510 with recommended Maintenance/Safety areas.....	11
Detailed Plan View - EM 2510.....	12
Elevation View – EM 2510	13
Plan View – EM 2510.....	14
Foundation Requirements	15
Foundation Anchoring Procedure.....	16
Ideal Foundation Plan View	17
Ideal Foundation Elevation View.....	17
Alternative Anchoring Method (Amada Machine Mounts with Drilled Hole, Anchor Rod and Adhesive).....	18
Drilled Hole with Anchor Rod and Adhesive Mounting Procedure	19
Removing the Protective Coating	21
Machine Leveling.....	22
Rocking Test	23
Floor Condition: Crowned.....	24
Floor Condition: Sloped.....	25
Leveling Procedure	26

Introduction

This manual describes the tasks that the purchaser of a EM2510 must complete before calling the service organization to complete the installation and operator training.

An overview of the preparations is as follows:

- Plan the location of the EM2510 in the shop, taking into account all the maintenance areas indicated on the floor plan. See page 10, *Planning the Location of the Machine*, for details.
- Prepare the EM2510 floor or foundation as required. See page 15, *Foundation Requirements*, for details.
- Uncrate the EM2510 and place on the foundation.
- Install the electrical supply. See page 7, *Electrical Requirements*, for details
- Install the pneumatic supply. See page 9, *Pneumatic Requirements*, for details.
- Remove the protective coating from the surface of the EM2510 See page 21, *Removing the Protective Coating*, for details.

Note: It is the purchaser's responsibility to install any safety devices to ensure the safety area.

Motion Package Specifications

Travel Method	X and Y axes work piece movement
Control Method	X, Y, T & C
Drive Motors	Fanuc AC Servo (X, Y, T, C, Z1, Z2)
Maximum Sheet Size	50" (Y) x 196.85" (X) with one repositioning cycle. (Additional material support tables required when processing material over 100" in the X-axis)
Maximum Sheet Thickness	0.135"
Maximum Material Weight	110 lb. At F1 (330 lbs. At F4)
Maximum Axis Travel	98.425" (X) by 50" (Y)
Max. Linear Table Speed (X / Y / Combined)	3934 ipm / 3149 ipm / 5039 ipm
Punching Accuracy	±0.004" (±0.0027" in High Accuracy Mode)
Positioning Accuracy	±0.001"
Repeatability	±0.001"

Punching System Specifications

Press Capacity	22 Tons		
Press Stroke	1.456"		
Stroke Rate (X/Y)	Pitch	Stroke	Stroke Rate
	0.079"	0.236"	780/498
	1.000"	0.236"	500/330
Maximum Hole Diameter	4.500"		
Tool Type	Amada Thick Turret		
Turret Rotation Speed	33 RPM		
Feed Clearance	0.984"		
Auto Index Rotation Speed	60 RPM		

AMNC-F Controller

Model	AMNC-F
Control Function	X, Y, T, C, Z1, & Z2
Input Method	Floppy Disk, CD ROM, USB, Ethernet, MDI, DNC
Minimum Command Unit	0.001" (X, Y) 0.01 ⁰ (C)
Minimum Travel Unit	0.001" (X, Y) 0.01 ⁰ (C)
Operating Modes	Automatic, MDI & Manual
Display Modes	Program Contents, Position Information, Program Check, Turret load, Program Set-up, Parameters, Tool Hit Counter, Self Diagnostics
Interlock Displays	Door Open, Clamp Open, X-Gauge block up.

Ram Control Features:

Ram Cycle Patterns	277 Total Punching 3 Nibbling 1 Forming 250 Marking 10 Knockouts 10 Slotting 4
Minimum Programmable Increment	0.001"

Electrical Requirements

EM2510	200 VAC 3 PHASE 60 HZ. $\pm 10\%$, 65 Amps, 22 kVA 230/460 requires step-up transformer (30 KVA recommended)
--------	--

Optional Equipment

Conveyor	208 / 230 / 460 3ph $\pm 10\%$, kVA 2.1 amps @ 208 / 3 / 60 VAC 2.0 amps @ 230 / 3 / 60 VAC 1.0 amps @ 460 / 3 / 60 VAC
MP1225 Loader	200 / 3 / 60 $\pm 10\%$, 10 Kva 29 amps @ 200 / 3 / 60 VAC To operate at 230 / 460 VAC a step up transformer is required with the following service is required 26 amps @ 230 / 3 / 60 VAC 13 amps @ 460 / 3 / 60 VAC

Installing the Electrical Power Supply

The EM2510 should be supplied from a power line separate from those for welding machines or other machines that produce electrical noise.

The EM2510 electrical inlet is 75" above floor level at the rear of the AMNC-F control.

EM2510 electrical enclosure:

POWER CABLE INLET

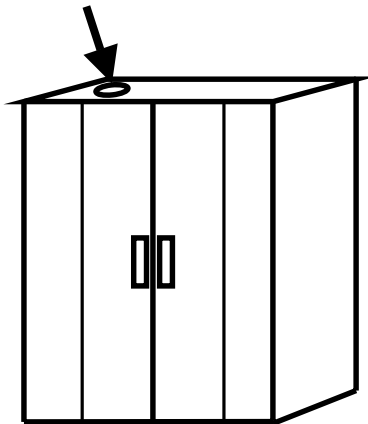

Main power connection



Pneumatic Requirements

EM2510	80 psi @ 8.8 ft ³ /min.
--------	------------------------------------

Optional Equipment

MP1225 Loader	75 psi @ 31.8 ft ³ /min.
---------------	-------------------------------------

Installing the Air Supply

The EM2510 requires connection to a compressed air system by hose or pipe. The compressed air must be clean and dry.

The minimum pipe inside diameter is ½".

The air inlet is approximately 16" above the floor level at the front-left side of the EM2510.

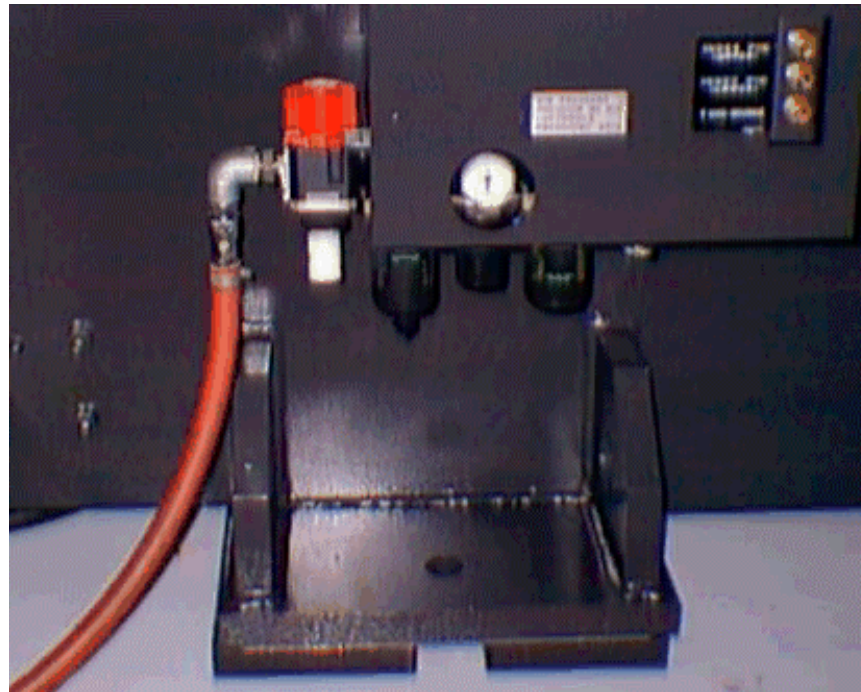

Planning the Location of the Machine

The following diagrams provide the details for positioning the EM2510.

- ❑ No obstacles are allowed in the worksheet travel area and the ceiling must be at least 40" above the top of the EM2510.
- ❑ All of the recommended maintenance areas should be used, but at a minimum the doors of the AMNC-F NC unit must be able to be opened. Any reduction of the listed maintenance areas may increase time and expense of installation and maintenance
- ❑ The EM2510 and AMNC-F control must be protected from direct sunlight or other heat sources. Direct exposure to direct heating sources such as infrared heaters have been shown to affect punch and die alignment.

Moving the EM2510

Lifting or moving of the EM2510 should be done only by professional rigging companies well versed in the moving of large and heavy industrial machinery. Acceptable moving methods include, lifting by overhead crane as shown, wheeled dollies beneath the machine feet, or adequately sized forklift forks beneath the machine frame.

The EM2510 has a relatively high center of gravity and narrow footprint care must be taken to prevent inadvertent tipping of the machine while in motion.

Machine Weight = 20tons (44,000 lbs)

Caution: Extremely Top Heavy Load

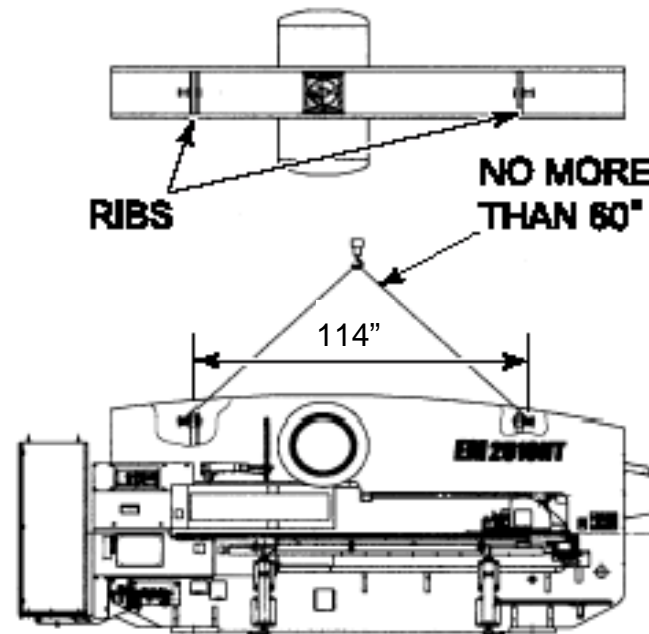
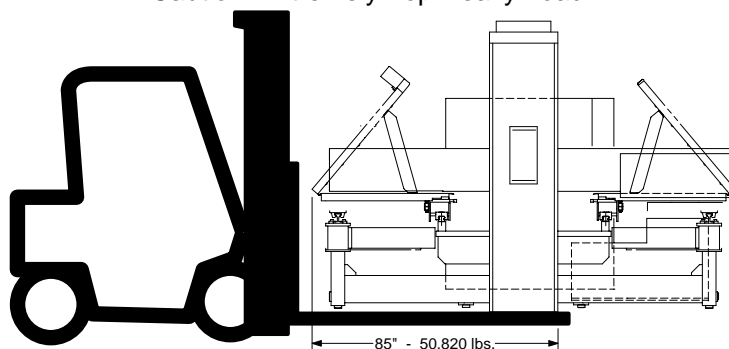

Plan View – EM 2510 with recommended Maintenance/Safety areas.

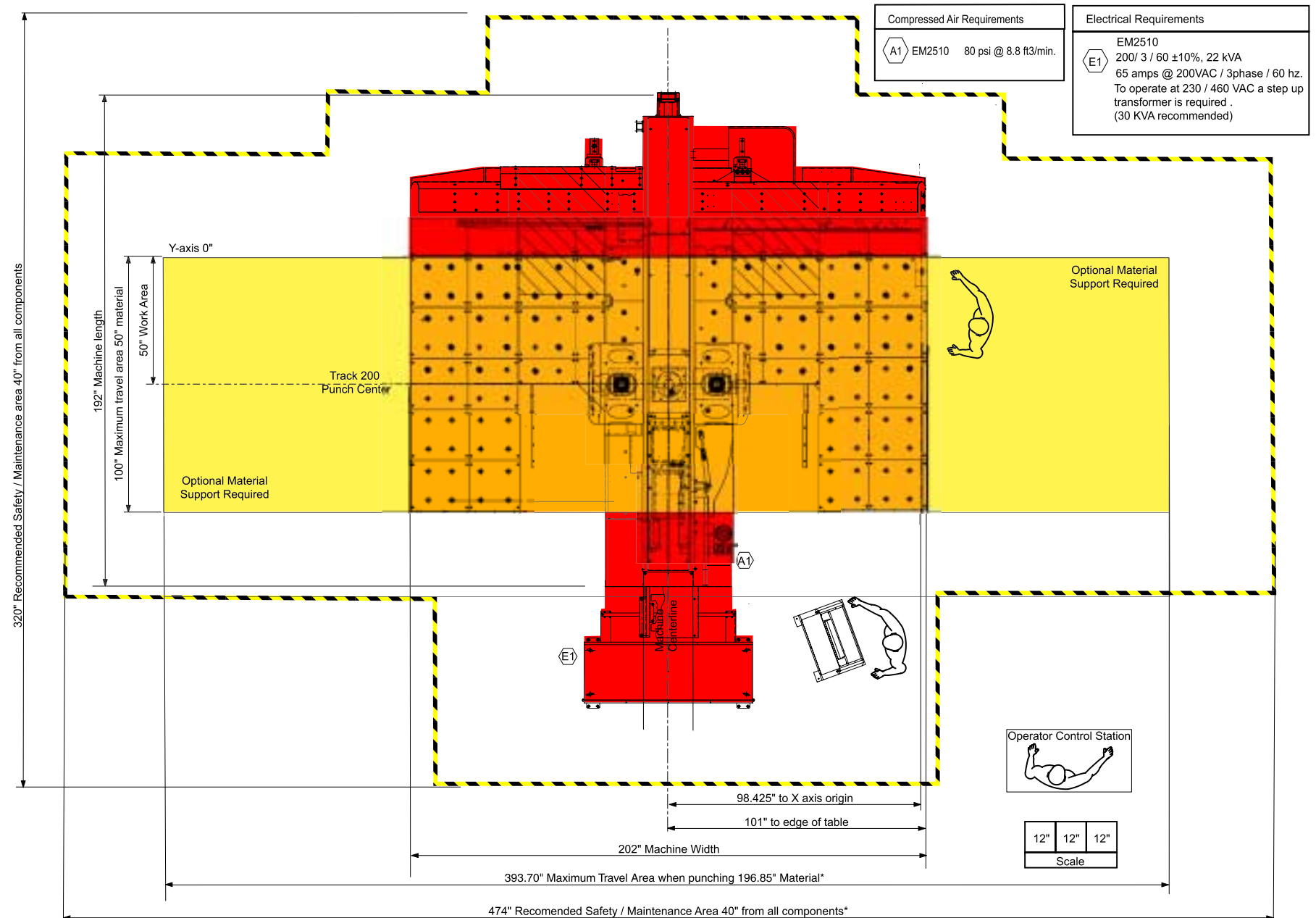

* Actual clearance depends on the maximum size of the material that will be punched
 - Always use sub tables to support sheets larger than 100"

Detailed Plan View - EM 2510

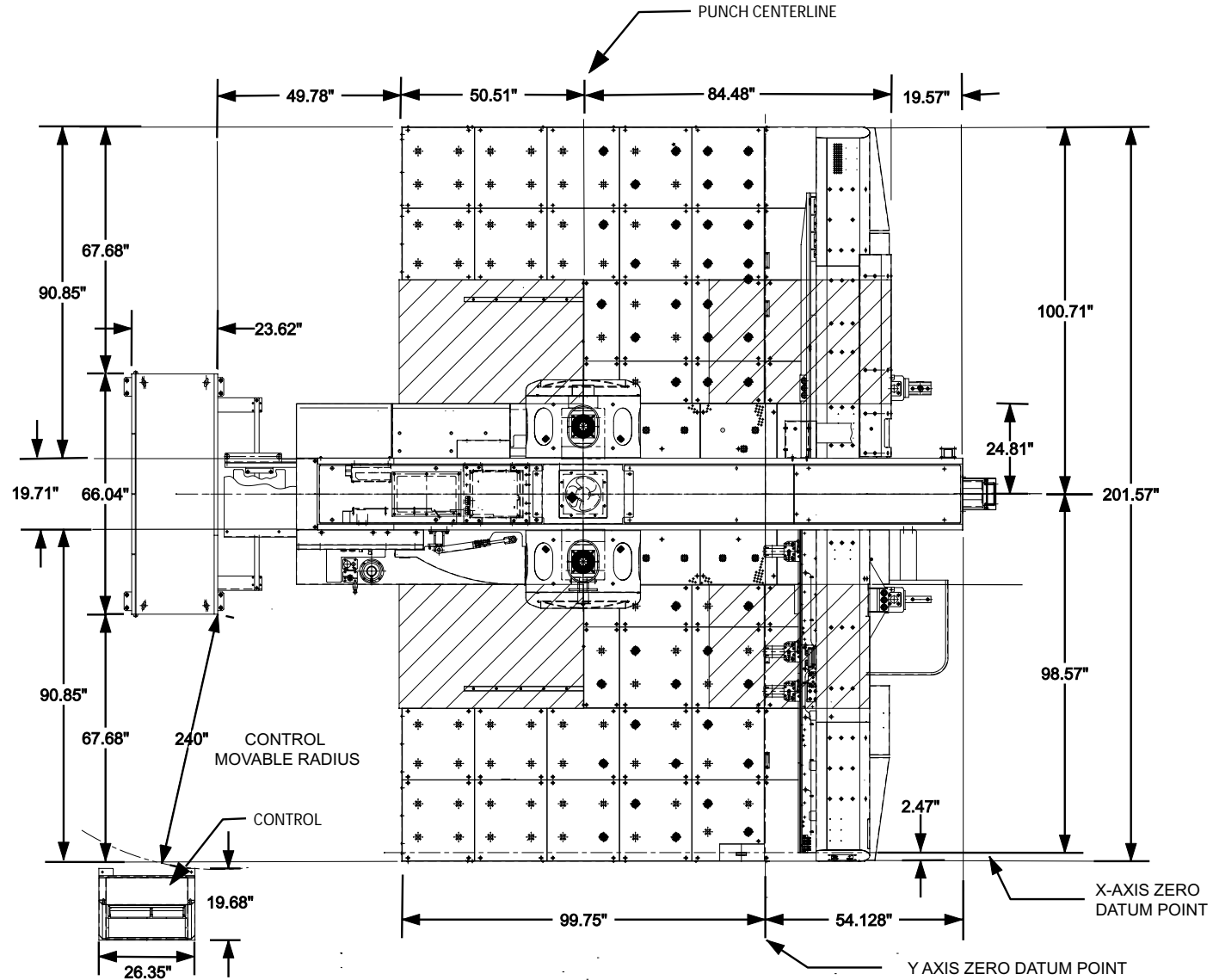

Elevation View – EM 2510

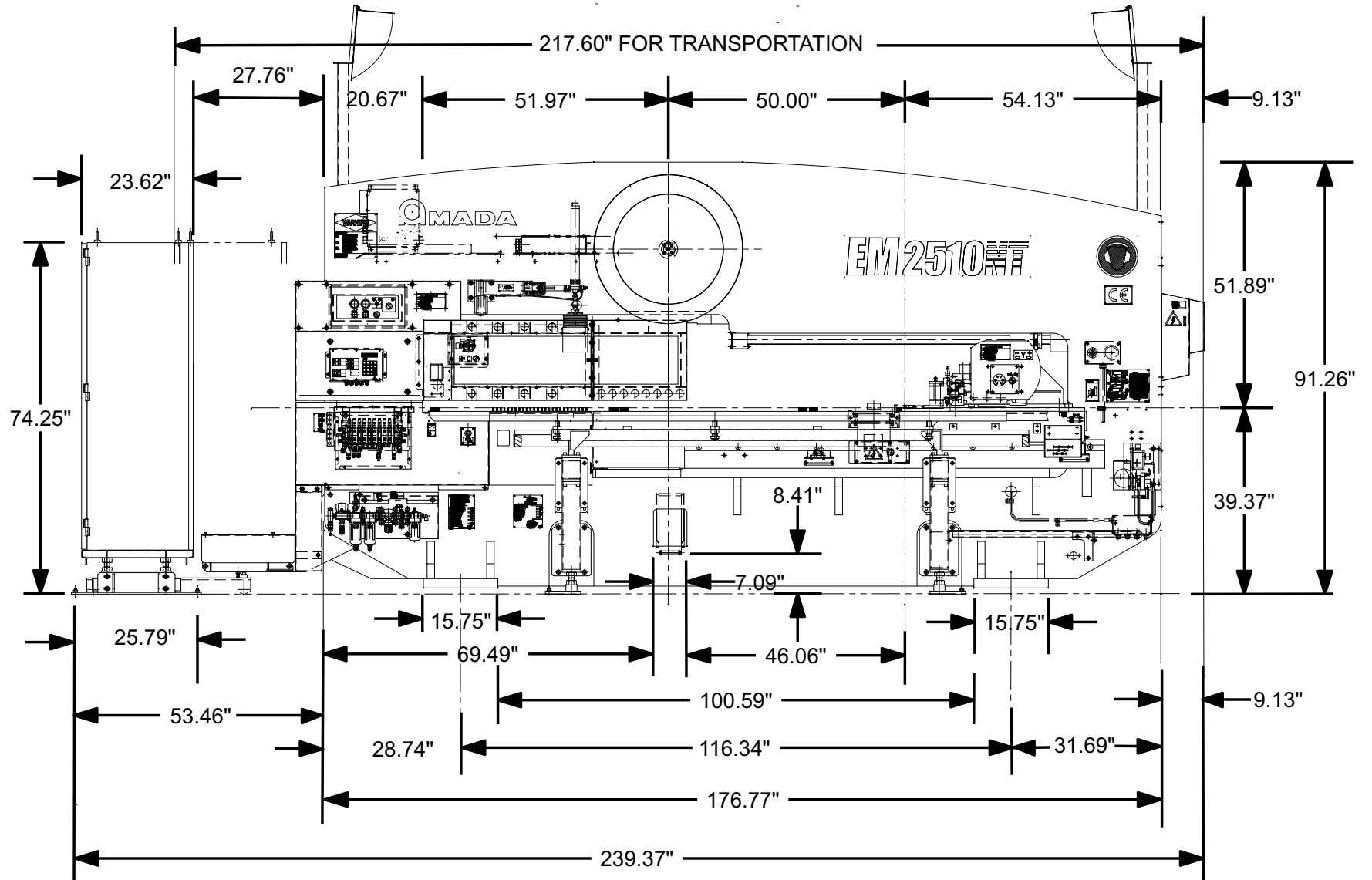

Plan View – EM 2510

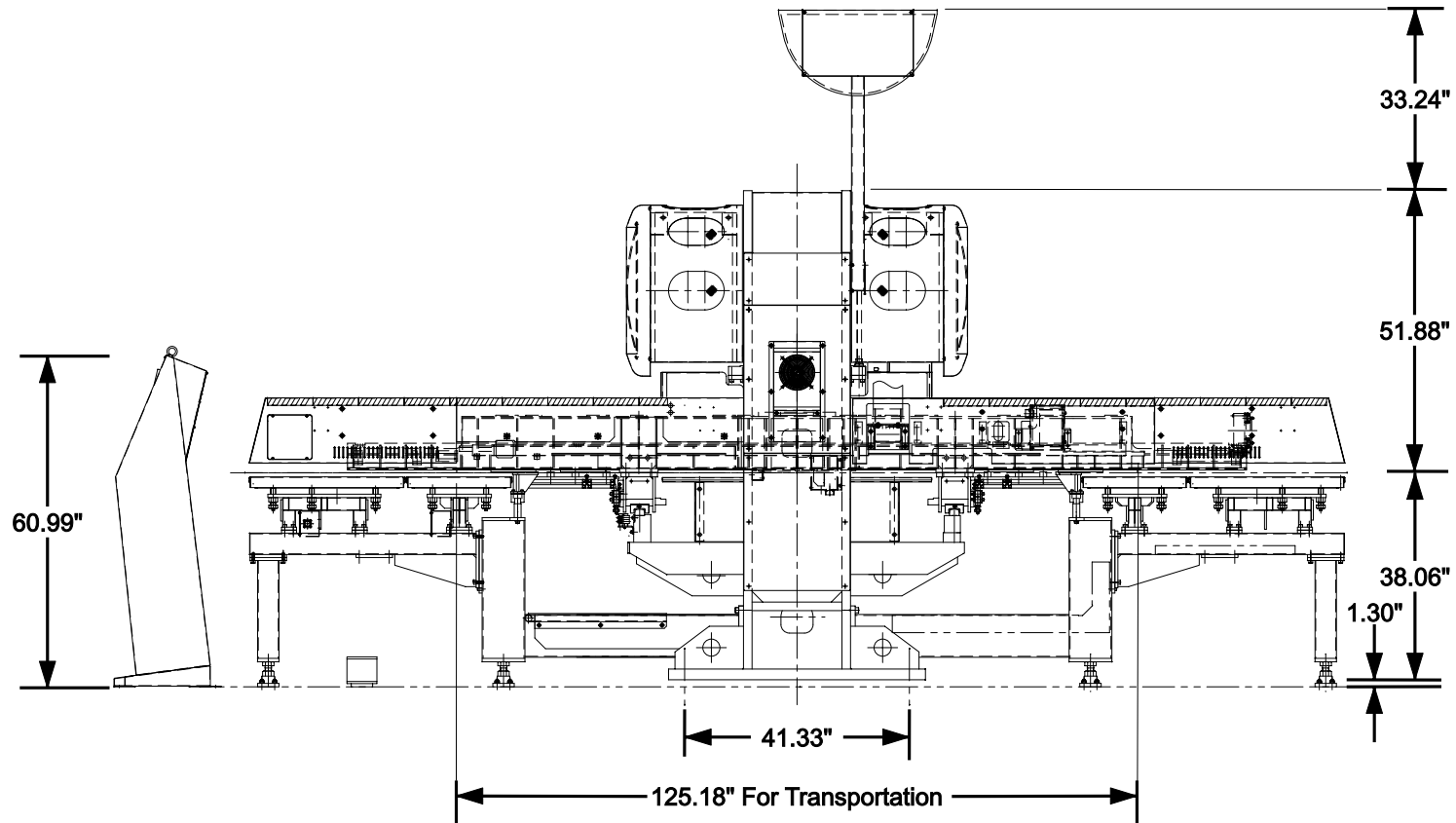

Foundation Requirements

The EM2510 does not require a special foundation to perform as expected, however there are minimum requirements that an existing floor must meet in order to assure machine reliability and tool life. If the existing floor does not meet the following minimum requirements, plans for a recommended foundation are given in the *section Foundation Anchoring Procedure* of this document.

The minimum acceptable floor conditions to assure a successful installation are:

- The area of the floor where the machine frame is to be located must be a single, homogeneous slab in good condition. There must be no cracks or other signs of deterioration of the floor.
- The floor must be 4" to 6" thick.
- The floor must be capable of supporting 3.5 tons/ft².
- The floor must be level to 0.032"/ft.

It is the customer's responsibility to determine that the floor meets these minimum requirements. Placing the machine on an inadequate, cracked floor, or straddling seams in a floor may be grounds for voiding the machine warranty! If there is any question that the floor is not adequate, then a new machine location or new foundation must be considered.

Amada America, Inc. does not recommend the use of vibration isolating mounts under the machine feet, as these devices have been shown to increase the vibration within the machine frame, increasing the likelihood of vibration related problems. Solid leveling devices are acceptable provided they incorporate a means of anchoring the machine to the floor.

Special Note: This document details several methods of anchoring the EM2510 to a new foundation or an existing floor. These methods are designed to install the EM2510 as a stand-alone machine using the "AY" base plates, which are included with the machine, or, installation using optional Amada Machine Mounts (Spherical Seat Wedge Mounts). Installation or use of additional options such as leveling pads or material handling systems may dictate other methods of anchoring or foundation design not shown in this document. Before committing to a specific method of anchoring the EM2510, confirm that the chosen method is compatible with all purchased optional items and planned expansion.

Foundation Anchoring Procedure

An ideal foundation is given on the following pages. This foundation must be used if the existing floor cannot meet the minimum requirements to support the machine.

The foundation must consist of a single, homogeneous slab. The foundation must be level to within 0.032" / ft. Anchoring the EM2510 to the floor using the anchor-bolts supplied is essential to ensure reliable performance. Amada generally recommends that the foundation have a minimum load bearing capacity of 3.5 ton/ft². It is the purchaser's responsibility to determine that the foundation meets these requirements.

Please note the following:

- The machine is shipped with "AY Plates" for anchoring to the floor using customer supplied anchor bolts.
- A second method using optional Amada Machine Mounts (Spherical Seat Wedge Mounts) and epoxy anchor bolts is also available. The Amada Machine mounts make achieving and maintaining the correct level of the machine easier and faster.

Ideal Foundation Plan View

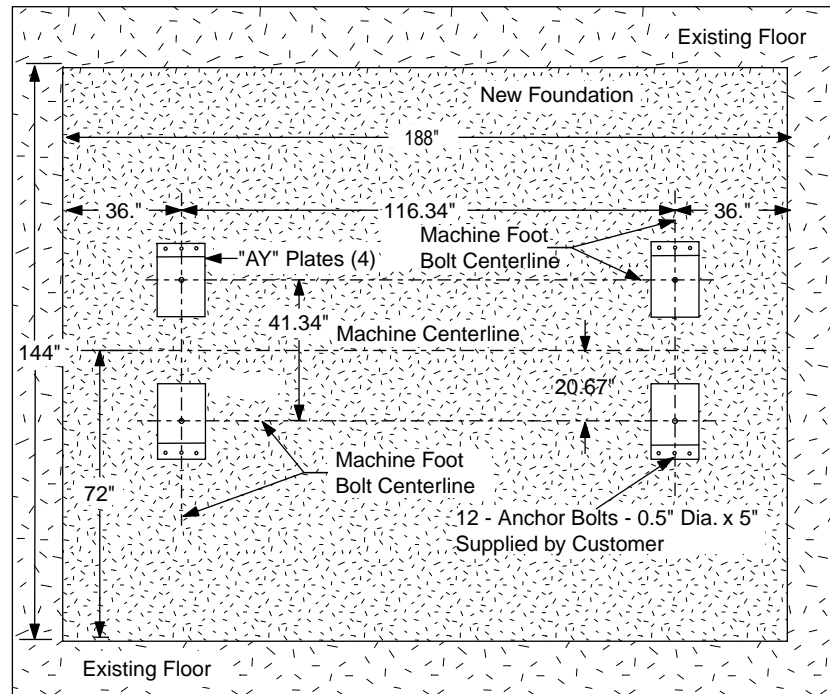

Ideal Foundation Elevation View

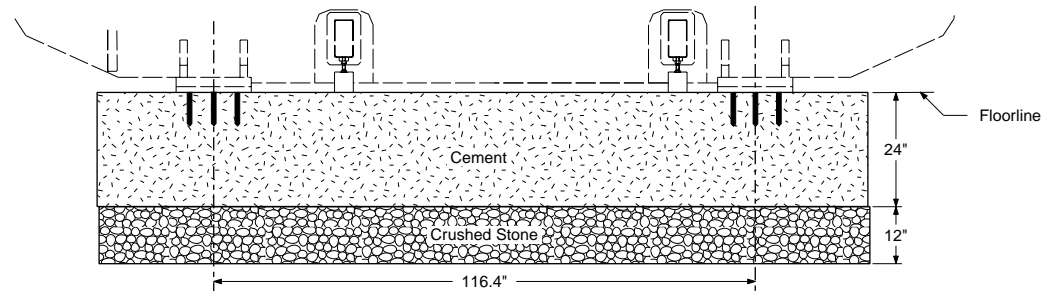

Alternative Anchoring Method (Amada Machine Mounts with Drilled Hole, Anchor Rod and Adhesive)

This machine mounting method should be used with the optional Amada Machine mounts (Spherical Seat Wedge Mounts).

Alternative Floor Bolt Mounting Method Plan View:

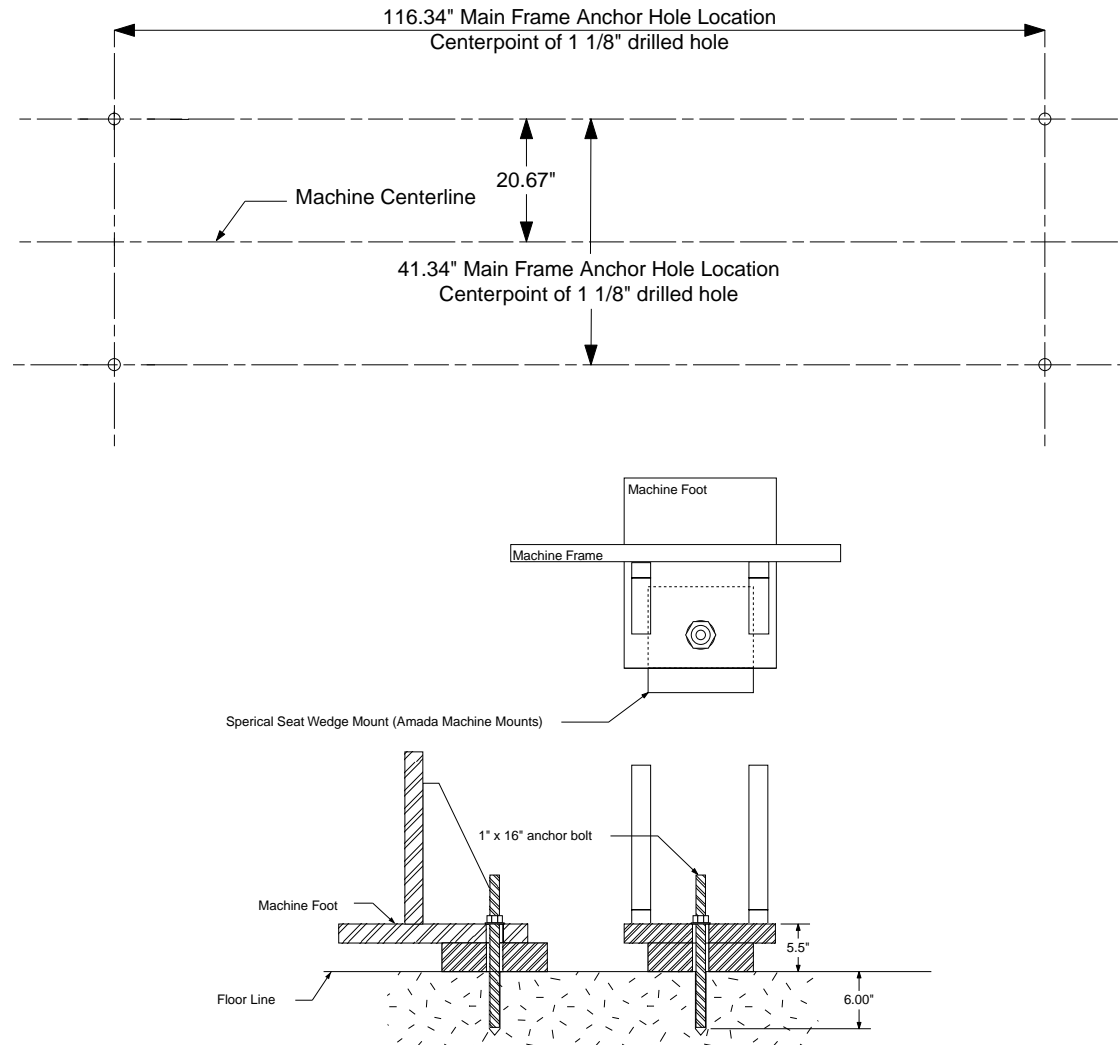

Drilled Hole with Anchor Rod and Adhesive Mounting Procedure

Step 1. Pre-Drill the four Anchor Rod holes in the existing floor prior to placing the machine.

The holes should be drilled approximately 6" deep.

See *Alternative Floor Bolt Mounting Method Plan View (Drilled Hole with Adhesive Anchor Rod)* for correct layout dimensions.

Step 2. Set the Amada Machine Leveling pads over the drilled holes

Step 3. Set the machine on the machine leveling plates.

Step 4. Level the machine frame by adjusting the Amada machine leveling pads.
See *Leveling the Machine* section for correct procedure.

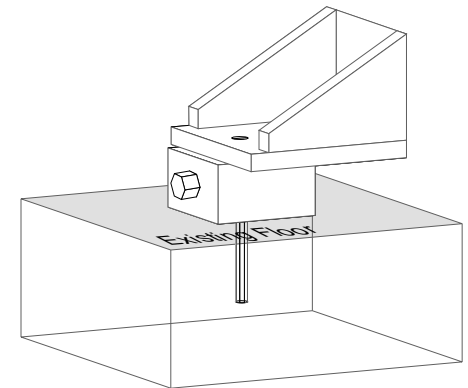
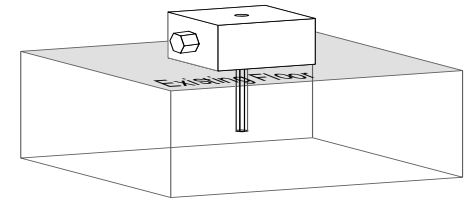
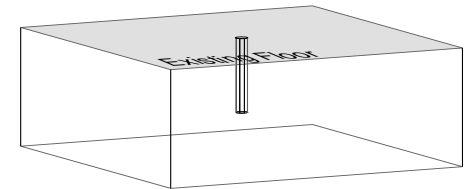

Step 5 Fill each of the Anchor Rod holes to within 2 inches of the floor surface with the Adhesive compound. Do not overfill.

Step 6 Attach the hex nut and flat washer on the Anchor Rod and place the Anchor Rod into the drilled hole.

Using a twisting motion to move the Anchor Rod through the epoxy compound, seat the flat washer and hex nut against the top of the machine foot.

Step 7 Allow the Adhesive to harden for 24 hours.

Step 8. Tighten the 4 hex nuts.

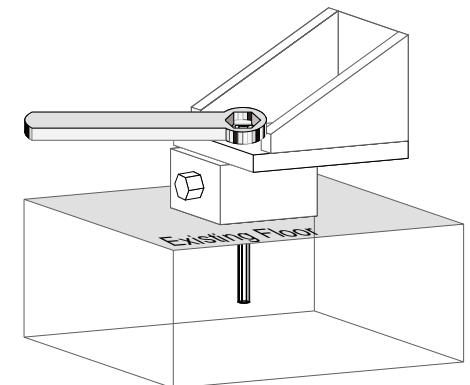
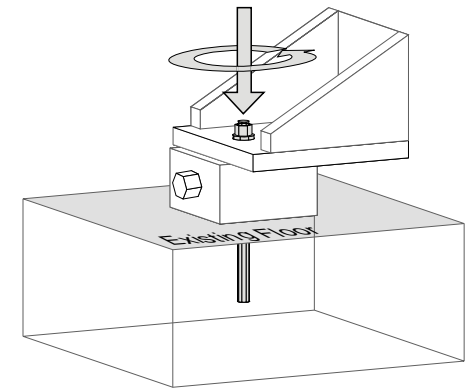
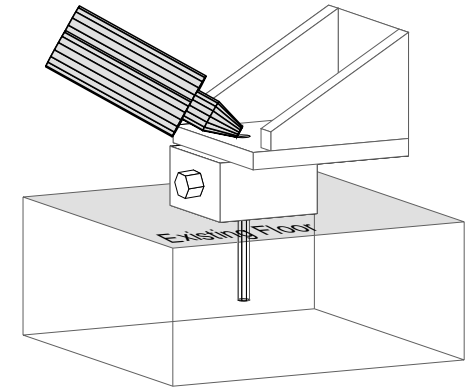

Removing the Protective Coating

The EM2510 must be thoroughly cleaned of protective coating. The sheet metal guards can be removed from around the turret to allow cleaning of the upper and lower turrets, tool bores and die holders.

- Please note the following:
- Remove wrapping paper from the X and Y-axes ball screws, then remove the protective coating.
- Remove the wrapping paper from the X and Y LM guides then remove the protective coating, make sure that you remove the paper from both sides of the carriage.
- Clean die holders one at a time. Remove a die holder, clean and replace it before removing the next die holder. If the die holders are mixed up, serious turret alignment problems may occur.
- A suitable solvent should be used to remove the protective coating.

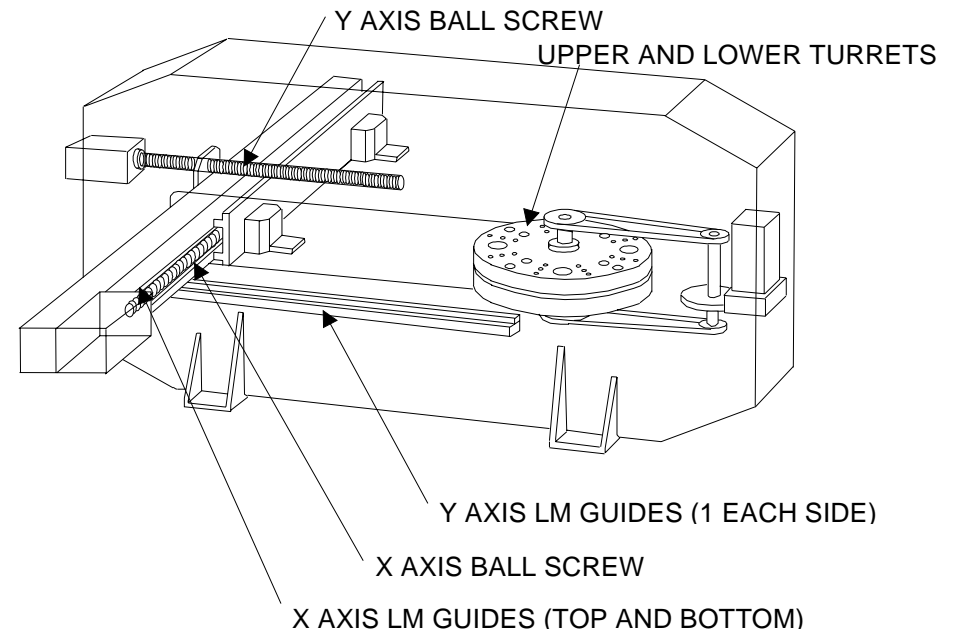

Machine Leveling

Proper Machine leveling is critical to the EM2510 performing as designed.

Materials and tools required:

Supplied with the machine:

- Assorted thickness machine leveling shim stock

- Anchor bolts

Supplied by Amada Service:

- Spirit level capable of reading 0.0005"/ft

- One (1) 12 ton hydraulic bottle jack

Not supplied:

- Additional shim stock of 0.005" thickness may be required to achieve a properly leveled machine.

Rocking Test

After the machine frame has been leveled the use of the following G-code is necessary to determine that the machine frame is properly leveled and balanced.

Should the machine frame vibrate or move excessively during the rocking test the machine frame must be re-leveled using the procedure in this manual.

Should the proper leveling technique not eliminate the excessive frame motion, consideration must be given to relocation of the machine or replacement of the existing floor with an adequate foundation.

Repeat test with X-axis movement values of 0.500", 1.000", and 4.000"

G92X98.425Y50.

G06A.100B0

N1

G91G70X-.25Tttt(Use any valid tool number)

G70X.25

M97P1

G50

Floor Condition: Crowned

The flatness of the floor plays an important step in the leveling procedure of the machine. To properly level the machine the weight bearing points must be as far from the centerline of the machine frame as possible.

Should a condition known as crowning exist the weight bearing points of the machine may not be far enough from the machine centerline to ensure a stable machine.

Under these conditions, a procedure known as *Half-Shimming* should be used.

To move the weight bearing points further from the machine centerline the use of half-shims of .125" thick on top of the base plate as shown is recommended.

After the half-shims are installed and the machine frame is leveled, use the rocking test to determine that the machine frame is stable enough to allow production without damaging the machine.

Under extreme conditions the use of half-shims may not move the machine weight bearing points far enough from the machine centerline to ensure the machine frame is stable.

Under these conditions, a more suitable location must be found for the machine, or a new foundation for the machine will be necessary.

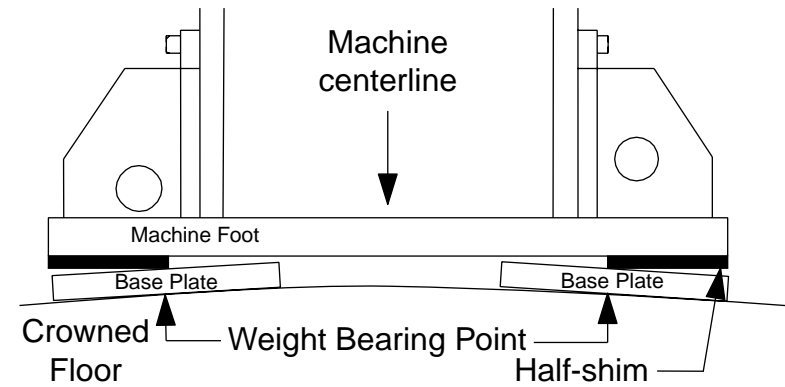
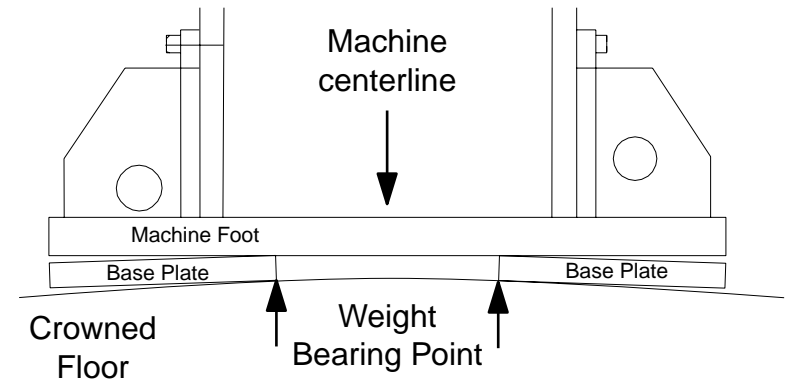

Floor Condition: Sloped

The slope of the floor plays an important step in the leveling procedure of the machine. To properly level the machine the weight bearing points must be as far from the centerline of the machine frame as possible.

Should the floor slope excessively the weight bearing points of the machine may not be far enough from the machine centerline to ensure a stable machine.

Under these conditions, a procedure known as *Half-Shimming* should be used.

To move the weight bearing points further from the machine centerline the use of half-shims of .125" thick on top of the base plate and leveling shims as shown is recommended.

After the half-shims are installed and the machine frame is leveled, use the rocking test to determine that the machine frame is stable enough to allow production without damaging the machine.

Under extreme conditions the use of half-shims may not move the machine weight bearing points far enough from the machine centerline to ensure the machine frame is stable.

Under these conditions a more suitable location must be found for the machine, or a new foundation for the machine will be necessary.

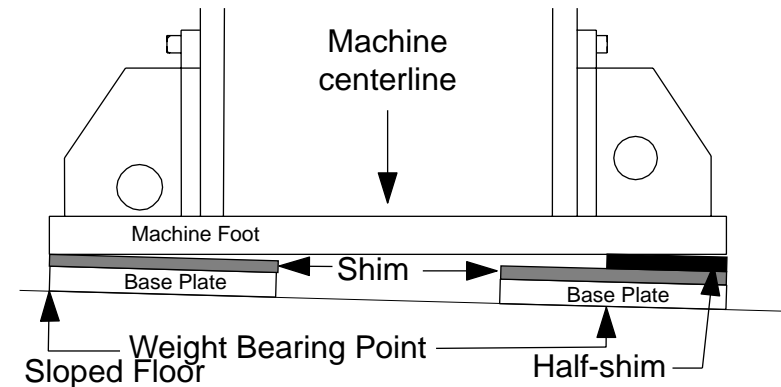
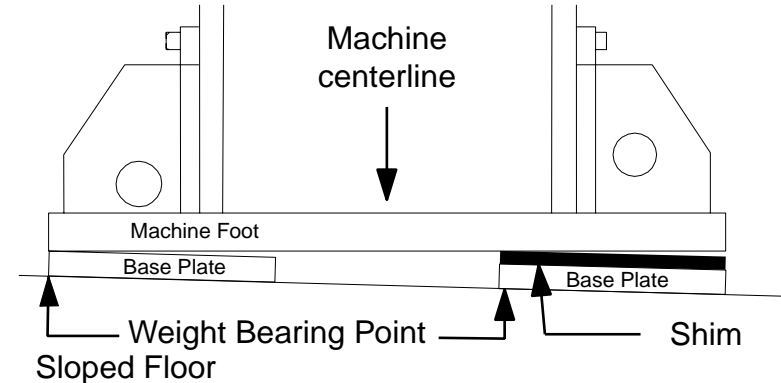

Leveling Procedure

1. Determine the high end of machine frame by placing a spirit level on the turret to measure the level of the machine frame in the y-axis.
2. Use the bottle jack to lift the low end of the machine frame. With the turret end of the machine frame slightly higher than the carriage end. Shim beneath both machine feet and the base plates until the machine frame measures near level on the y-axis.
3. Center the bottle jack under the carriage end of the machine frame. Lift the machine frame until all weight is off the machine feet at the carriage end of the machine frame. Lift the machine frame as little as possible to take the weight off the base plates.
4. With the machine supported on the bottle jack at the carriage end of the machine frame and the machine feet at the turret end of the machine frame, place a spirit level on the turret.
5. Measure and record the level of the turret in the x-axis then lower the machine frame to place all machine feet in contact with the leveling shims and base plates.

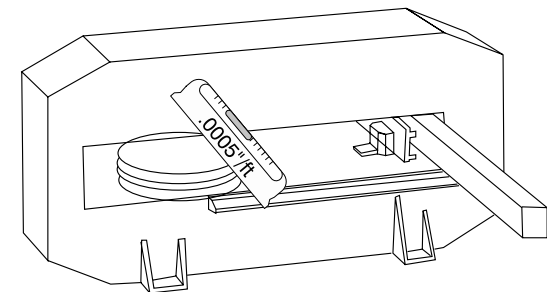
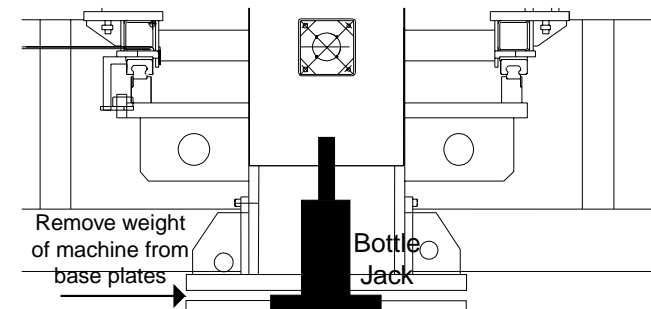
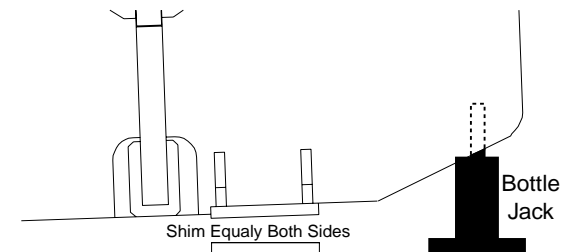
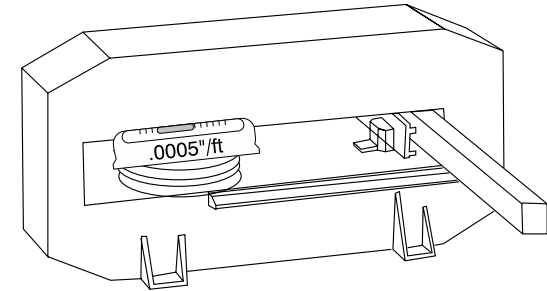

6. Lift the turret end of the machine frame to allow shimming between the machine feet and base plates to level the machine frame in the x-axis.
7. Repeat steps 3 to 5 until the machine frame measures level to 0.0005"/ft in step 5, then continue.
8. With the weight of the carriage end of the machine supported by the bottle jack. Monitor the level of the turret in the x-axis, as the bottle jack is slowly lowered to place the carriage end machine feet in contact with the base plates. Any change in the level indicates that the carriage end of the machine needs to be leveled.
9. Lift the carriage end of the machine frame to allow shimming between the machine feet and base plates to level the carriage end of the machine frame in the x-axis direction.
10. Repeat steps 8 and 9 until no difference in level is noted when the machine weight is on or off of the base plates and shims, then continue.
11. With all of the machine feet setting on the shims and base plates place the spirit level on the turret to measure and note the level of the machine frame in the y-axis.

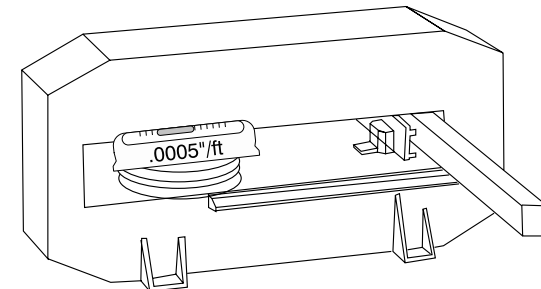
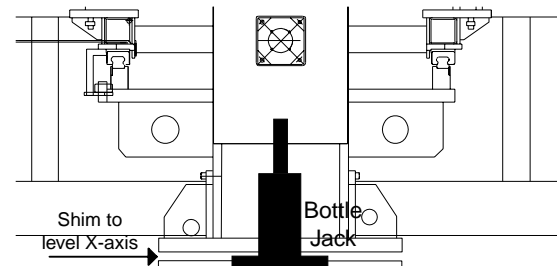
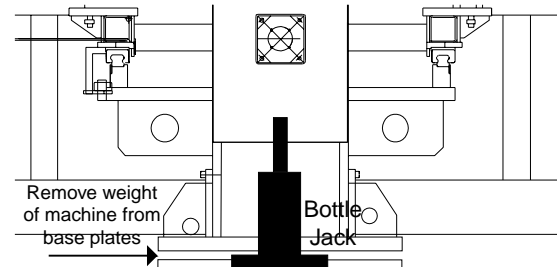
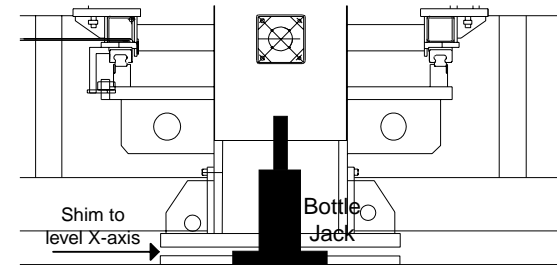

12. Using the bottle jack lift the low end of the machine frame and shim equally under both machine feet to level the machine frame in the y-axis.
13. Repeat step 11 to 12 until the machine frame measures level to 0.0005"/ft in the y-axis then continue.
14. Run the machine using the rocking test G-code to determine that the machine frame is leveled adequately. Should excessive movement of the machine frame be noticed check for the conditions discussed in *Floor Condition Crowned* and *Floor Condition Sloped*.
15. Tighten the anchor bolt nuts to prevent the machine frame from moving when in use. Monitor the machine level while tightening the anchor bolts to assure the machine level is not changed.

