

AC 2007-1472: EMBEDDED DESIGN IN PARAMETRIC MODELING AND CAM

John Irwin, Michigan Tech University

Embedded Design in Parametric Modeling, and CAM

Abstract

The Mechanical Engineering Technology (MET) BS degree recent curriculum enhancements have brought about the development of new courses for the 2006-07 academic year. The present course sequence requires a freshman level introduction to engineering fundamentals course where the Unigraphics NX 3D modeling software and various other engineering software are introduced. Later in the curriculum during upper level courses students are expected to utilize these engineering software programs to create project documentation and/or 3D models for analysis and manufacture. This computer graphics course requires students to become proficient with the graphics software through lecture, demonstration, lab projects, and online tutorials.

Usually, the graphics courses taught in engineering technology programs do not integrate design topics along with the operation of the software. During a recent restructuring of the BSMET program at Michigan Technological University (Michigan Tech) certain traditional courses were eliminated and embedded into new courses. Some of the courses that are not offered as stand alone courses are geometric dimensioning and tolerances, descriptive geometry, manufacturing processes, and machining fundamentals. The new sequence of computer graphics courses in the BSMET curriculum are Technology Computer Applications, Practical Applications in Parametric Modeling, and Computer Aided Manufacturing.

The Technology Computer Applications course introduces the multiple applications of the Unigraphics NX software capabilities in the context of a design project involving modeling, drafting, structures, manufacturing, and motion. The course also introduces applications in the Microsoft Office Suite related to the computer graphics project using Excel, Project, PowerPoint, and Word. The Practical Applications in Parametric Modeling course integrates Unigraphics NX modeling, assemblies, motion and drafting modules also using a design project approach. This course utilizes the smart models tools in the CAD software to apply embedded geometric dimensioning and tolerances on 3D models, uses the drafting and analysis tools to solve descriptive geometry problems, and uses the scenario motion application to solve kinematics/dynamic related problems. Finally, the Computer Aided Manufacturing course utilizes the Manufacturing module to generate virtual tool paths for verification, machine tooling interference checking, and post processing while creating design projects that integrate manufacturing processes and principles.

Upon completion of the courses in the computer graphics sequence the goal is that students will be better prepared to accomplish tasks required during the senior project capstone courses. The pedagogical challenges, advantages, and disadvantages, as well as student reaction to the computer graphics courses will be discussed. Actual examples of student design projects will be presented as examples to illustrate the embedded nature of the integration of design related topics in the graphics courses curricula.

Introduction

At Michigan Tech, the School of Technology (SOT) is home to six Bachelor of Science Degree Programs; Computer Network and System Administration, Construction Management, Electrical Engineering Technology, Industrial Technology, Surveying Engineering, and Mechanical Engineering Technology (MET). The SOT is one-sixth the size of the College of Engineering in which the majority of the university’s approximately 5,500 undergraduate students are enrolled. The MET program is an ABET-accredited program and enrolls the most students of any SOT program—approximately 200 students. The SOT started offering Baccalaureate degrees in 1994 and recently stopped offering Associate’s Degrees. This administrative decision was based partly on the desire to not compete with what community colleges do best; delivering well-qualified technicians to the workforce. Along with the elimination of the Associate degree option, the MET curriculum was redesigned based on extensive benchmarking of comparable university degree offerings, industry needs, and advisory input. Table 1 provides a summary of the computer graphics course descriptions and the impact they have on the program and students.

Table 1 Computer Graphics Courses

Course Number and Title	Course Description	Impact on Program and Students
<i>TE 1010 Technology Computer Applications</i>	<i>An introduction to parametric modeling and will act as a foundation for additional studies in solid modeling</i>	<i>Foundation to parametric modeling. Skill set to be used in following courses.</i>
<i>MET 2400 Practical Application in Parametric Modeling</i>	<i>Expand student knowledge of computer modeling techniques, and introduce advanced assemblies and GD&T concepts. Investigate advanced concepts available to the designer.</i>	<i>Intermediate course critical to all program concentrations. Provides student with skill set not previously integrated into program</i>
<i>MET4550 Computer Aided Manufacturing</i>	<i>Course designed to apply techniques used in parametric modeling and student design courses to produce machine code and manufacture components utilizing CAM methods.</i>	<i>Course added and deemed critical by employers, Industrial Advisory Board and Students. Course required for concentrations in Manufacturing and Computer-Aided Engineering</i>

At Michigan Tech the present MET degree has three focus areas that students can choose electives during their junior and senior year which are: Manufacturing, Computer Aided Engineering (CAE), or Fluids and Power Systems. The three courses; Technology Computer Applications, Practical Applications in Parametric Modeling, and Computer Aided Manufacturing (CAM) are included in both the Manufacturing and CAE focus areas. The CAM course is described as a course designed to apply techniques used in parametric modeling (CAD) and convert this information to all phases of production

planning, machining, scheduling and quality control. An earlier course in the curriculum which serves as one of the prerequisites is Integrated Design and Manufacturing, which focuses on practical aspects of design and manufacturing incorporating CAM tools. It covers fundamentals of manufacturing processes and includes weekly lab providing hands-on experiences with manufacturing issues that influence component design. These courses prepare students for the Computer Numerical Control (CNC) and CAM skills necessary to model and manufacture parts required for production during later courses in the curriculum.

As a capstone experience at Michigan Tech, senior year MET students from each of the focus areas are required to complete a team-based senior design project. Students progress through a two semester sequence starting with Product Design and Development presenting integrated methodologies that examine marketing, manufacturing, and cross-functional teams including concurrent engineering and projects utilizing CAD systems, and ending with a Senior Project course including evaluation and design optimization methods for efficient and cost-effective designs requiring an oral/written report and comprehensive exam. In the capstone sequence the student teams first generate the design, optimize the design and document the design. Then, during the last semester the teams plan for production, manufacture and assemble components, and test their design using the skills acquired through the computer-aided engineering and manufacturing related courses taken in earlier semesters.

Embedded Design Rational

The rationale for the curriculum enhancement has been communicated to Michigan Tech from our industrial partners. These companies approached higher education to say, “We need the super engineer—one that can **design, develop, and manufacture** using today’s technology.” The Society of Manufacturing Engineers (SME) supports their assertion (Society of Manufacturing Engineers, 2002)⁴. Also, the National Association of Manufacturers recently identified critical key competency gaps in graduating manufacturing engineers and technologists (Deloitte, National Association of Manufacturers and the Manufacturing Institute, 2005)². These gaps indicate U.S. engineering technology graduates have a poor understanding of manufacturing processes and principles. One of the strategies used to accomplish this goal is to embed design into the computer graphics course sequence.

According to the Merriam Webster’s Online Dictionary the definition of the term embedded is to make something an integral part of the topic, which is the objective in all three of the courses in the computer graphics sequence. The theoretical basis for using the embedded approach in these courses is illustrated in an article by Sutton, (2004)⁵, at Purdue University involving problem-solving research outside of technology education to help examine the relationship between problem representations, understanding the problem, and learning transfer to new situations. The purpose of this study is to provide the key components of a problem-solving model that may be useful for developing a theoretical framework for future research in the technology education field.

The underlying principle in the article is that problem solving in technology education merges the positive aspects of both behaviorism and constructivism. The author explains that even though much emphasis in the last two centuries has been focused on problem-solving curriculum development in technology education only a few studies have been focused on the problem-solving process in itself. The principles that guide the design of the article are based on cognitive psychology, which is to determine how information is stored and accessed in the memories of individuals called the representation of information.

The results of the research are presented in the contexts of problem representation and understanding, transfer of learning, and a model called the “Problem-solving Triad”. The first important facet of problem solving is the understanding of the problem, which is necessary before the learner moves to the solving process. Transfer of learning in problem solving situations was reported in several studies to help subjects focus on relevant strategies when presented with related problems, but when presented with different problem contexts it appeared to interfere with transfer. The cognitive science and mathematics education literature researched in this study suggest that the problem solving process involves three major facets: the solvers’ representation of the problem, the solvers’ background experiences, and the solvers’ understanding of the problem and its structure. The Problem-Solving Traid, (Hayes & Simon, 1974)³ is a model, which is represented by the base of the triangle as the experiences and representations depicting these characteristics as the foundation to problem solving. At the center of the triangle is learning transfer, where once the learner completely understands the problem and its structure, the transfer of learning can occur.

Embedded design projects focus on the notion of the learner constructing new ideas or concepts based upon their current and/or past knowledge, which encourages students to construct principles by themselves. The task of the teacher is to translate the information into a format appropriate to the learners’ state of mind and organize the materials in a spiral manner, (Bruner, 1966)¹. The spiral manner in which these materials are sequenced are achieved through revisiting the capabilities of the computer graphics software to model, analyze and document engineering projects during the introduction, intermediate and advanced courses.

Pedagogical Challenges

Of course the most difficult aspect of embedding a CAD or CAM project that involves design into an introductory or intermediate course is that it takes special care to ensure that students have the prerequisite skill context to understand the problem. The projects that are embedded in the courses change depending on the semester and instructor, but the concepts are similar.

➤ Technology computer Applications

In this course a project involving a mechanism in motion is used to introduce the applications of the computer graphics and word processing software. The students will be introduced to the basics of modeling while creating the components of the mechanism. The mechanism will then be assembled to reinforce the need for parametric relationships

necessary to constrain part location and orientation. Motion parameters are assigned to check for kinematics relationships of rotation and/or translation of parts and interference conditions. To further investigate the function of the design dynamic forces are extracted from the model to assess the loads at specific joints in the mechanism. Students at this time have not had courses in Statics and Strengths of Materials or Dynamics, so the problem is kept very basic. For example, the operation of a four bar linkage mechanism used as an automatic bottle opener as shown in Figure 1. The students create a basic CAM program for a contour milling operation on a part, and perform a basic FEA analysis given a load at a specific point in the mechanism. This data collected through modeling and simulation is entered in an MS Excel spreadsheet, MS Project is used to track the tasks assigned in the project, MS Word is used to create a report, and MS PowerPoint is used to create a presentation of the project to the class. This course then serves as the foundation for laboratory courses utilizing CAD and MS Office software tools.

Figure 1 – Bottle Opener Assembly

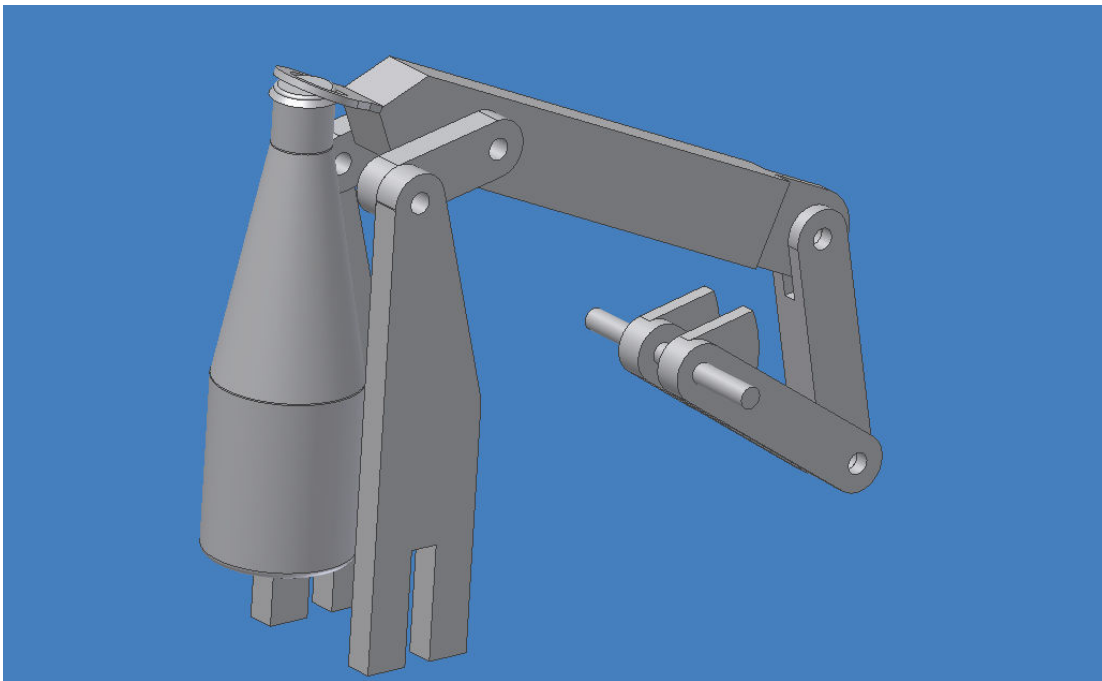

➤ Practical Applications in Parametric Modeling

The parametric modeling course integrates geometric dimensioning and tolerances, and descriptive geometry while creating 3D parametric models, assemblies and associative drawings. The theme of embedding design solutions in the computer graphics courses is continued in this course while students are presented with a scenario in which multiple parts of an assembly are manufactured in different facilities and part tolerances have to be specified so that the parts will fit within specified tolerances. An example of a project is a mounting flange and wheel hub assembly where true position tolerances are used to ensure the holes and wheel studs will align at assembly. Students use smart model tools in Unigraphics NX, as shown in Figure 2, to apply embedded GD&T notation to the 3D

model that can be extracted in the associative drafting layout. After applying the necessary tolerances to the product the students design a functional gage that is required to check for the true position of the holes in the part.

Figure 2 – Embedded Geometric dimensioning & Tolerances

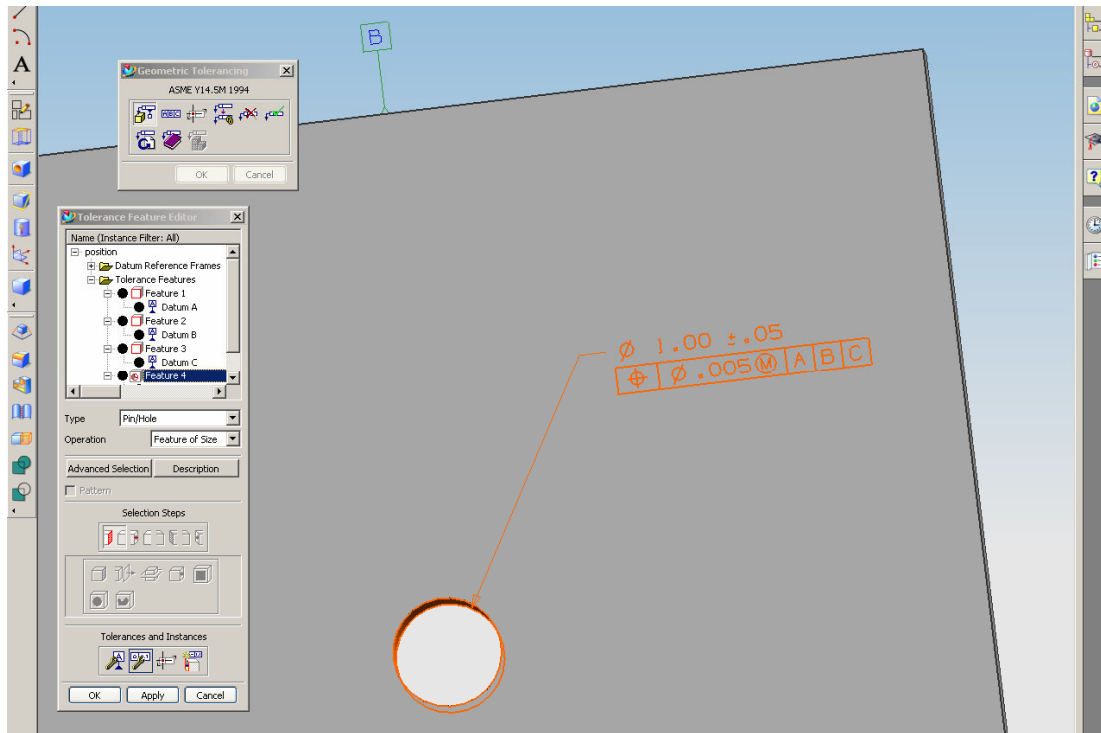

The descriptive geometry problems presented require students to analyze parts for true length, true angle, shortest distance, and model the geometry to solve the problem. An example of a descriptive geometry problem is to design a flexible connector between two non-parallel, non-perpendicular pipes that are at a designated distance apart. The connector will isolate the movement of each pipe, and can be easily fitted on and off the pipes. Students at this intermediate level have not had courses in Integrated Design and Manufacturing or Machine Design, so the part designs are very basic.

➤ Computer Aided Manufacturing

The previous MET curriculum included a machining course, which is no longer part of the curriculum. During the curriculum revision process, the machining course was dropped because the intention of the MET program was not to provide skilled machinists—instead, the goal was to provide engineering technologists skilled in hi-tech machining and manufacturing evaluation capabilities. Additionally, with the degree program growing in size it became increasingly difficult to offer an intensive hands-on introductory laboratory class to 50 new students every year. With the elimination of the machining course, manual lathes and milling machines were also removed.

So, without a manual machining course, the challenge in the curriculum design was how to create experiences for students to learn manufacturing processes and principles. A CAM course utilizing CNC capable mill and lathe machines was added to fill this gap. This CNC laboratory (presently under development), combined with the new CAM course curriculum also allows students to learn manufacturing principles and processes in an embedded project approach. As identified in the Manufacturing Engineering publication (Waurzyniak, Patrick, 2003)⁶, in recent years CAD/CAM developers have continued to add more functionality aimed at machining solid models, high speed machining, automatic feature recognition, tool path verification/simulation, and estimating job costs. As in the example shown in Figure 3 students use Unigraphics software to model the part, create the tool-path, simulate the tool-path, and check for machine/tooling interferences before post processing the program for the CNC mill or lathe. The students attend a lab section where they operate the CNC lathe and mill to support the lessons learned through the simulation of the machining process.

One of the embedded design problems used in the CAM course is to design a bottle opener using an aluminum blank size of .5 x 2 x 5 that is unique in it's shape, but can still be manufactured using a simple profile milling operation. Students designed several shapes that were functional as bottle openers, fit a standard milling fixture, but each had unique design characteristics. The varied designs required students to plan and validate their tool paths while checking for tool and clamping clearances.

Figure 3 – Tool-path machine tool interference checking

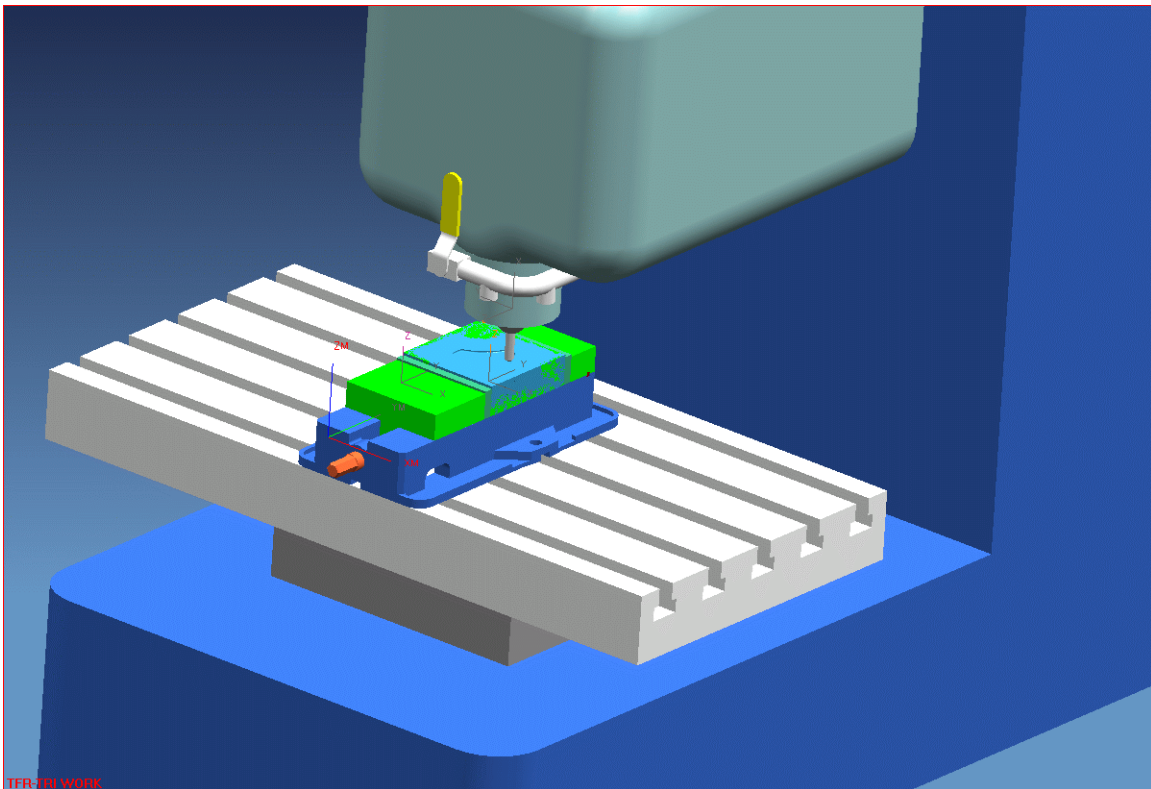

Advantages and Disadvantages

The advantage of the projects embedded in the computer graphics courses is that it allows students to apply what they are learning while solving a problem. The students are motivated to learn the process of creating the models and analyzing results, because they want to solve the problem presented. Students progress through the mechanics of how to operate the software quickly so that they can reach the goal of solving the problem sooner. Students retain the knowledge of using the computer graphics software, because they make a connection to how the software can be used in a design problem.

The difficulty with embedding the design problems into the courses is matching the complexity of the problem with the skill level and experience of the students. Also, estimating the amount of time to allow for the projects is challenging, because of the fact the students are still learning how to operate the software. The instruction technique used is to integrate the demonstration of how operate the software when it is most important to the student to solve a particular problem, and at that time the student is motivated to learn.

Results

The computer graphics courses are evaluated based upon student participation in classroom discussion/problem solving, individual solutions to design problems, timeliness and quality of project tasks counting towards 50% of their grade. The remaining 50% of the student's grade is determined by exams, group presentations, and project reports. Forty students were enrolled in the 2006-07 fall semester Parametric Modeling course, and 12 students in the CAM course.

The students were surveyed for their course satisfaction, and perception of the course content. The results of student satisfaction yielded an average of 4.6 on a scale of 5 as highly satisfied. Results obtained via informal student formative evaluation resulted in very positive feedback. Students feel very prepared to participate in their senior project sequence. Some students indicated that 2 hours was not enough time to complete the midterm and final modeling projects, so the final is now being delivered over two class settings.

Conclusions and Recommendations

The intention of embedding design in parametric modeling and CAM courses is to improve the competency gaps of U.S. engineering technology graduates, which have been indicated as having a poor understanding of manufacturing processes and principles. The future successes or failures of students in senior capstone courses will indicate whether the computer graphics courses are preparing BSMET students to apply the design skills in an industrial type situation. Also, long term studies are necessary to assess whether employers and students are satisfied with the preparation of BSMET students who have experienced the embedded design projects in the computer graphics courses.

References

1. Bruner, J. (1966). *The Process of Education*. Cambridge, MA: Harvard University Press.
2. Deloitte, National Association of Manufacturers and the Manufacturing Institute (2005). *2005 Skills Gap Report*. On the internet at <http://www.nam.org/2005skillsgap> (visited November 26, 2006).
3. Hayes J. R., & Simon H. A. (1974). Understanding written problem instructions. In Gregg L. W. (Ed.), *Knowledge and cognition*. Potomac MD: Lawrence Erlbaum Associates.
4. Society of Manufacturing Engineers (2002). *Manufacturing Education Plan, Phase III: 2001-2002 Critical Competency Gaps*, on the internet at http://www.sme.org/downloads/foundation/competency_gap.pdf (visited November 26, 2006).
5. Sutton, M.J. (2004). Problem presentation, understanding, and learning transfer implications for technology education. *Journal of Industrial Teacher Education*, 40(4), Retrieved August 17, 2004 from <http://scholar.lib.vt.edu/ejournals/JITE/v40n4/sutton.html>.
6. Waurzyniak, Patrick (2003). Software Boosts Shop Efficiencies. *Manufacturing Engineering*, 131(2) on the Internet at <http://www.sme.org> (visited March 6, 2006).