



EMC TEST REPORT

Authorized under Declaration of Conformity

According to

- | | |
|-----------------------------------|--------------------------------------|
| EN 55022 : 2010/AC:2011 (Class B) | EN 55024 : 2010 |
| EN 61000-6-3: 2007/A1:2011 | EN 50130-4: 2011 |
| EN 61000-3-2 : 2014 | IEC 61000-4-2 : 2008 |
| EN 61000-3-3 : 2013 | IEC 61000-4-3 : 2006+A1:2007+A2:2010 |
| | IEC 61000-4-4 : 2012 |
| | IEC 61000-4-5 : 2005 |
| | IEC 61000-4-6 : 2008 |
| | IEC 61000-4-8 : 2009 |
| | IEC 61000-4-11 : 2004 |

Applicant : Panasonic India Pvt. Ltd.
Address : 6th Floor, "SPIC BUILDING" Annexe, No. 88, Mount Road, Guindy, Chennai - 600 032.
Equipment : Network Bullet Camera
Model No. : PI-SPW403L
Trade Name : Panasonic

I HEREBY CERTIFY THAT :

The sample was received on Apr. 27, 2015 and the testing was carried out on May. 24, 2015 at CerpPASS Technology Corp. The test result refers exclusively to the test presented test model / sample. Without written approval of CerpPASS Technology Corp., the test report shall not be reproduced except in full.



EMC TEST REPORT

Issued by:

CerpPASS Technology (Suzhou) Co.,Ltd

No.66,Tangzhuang Road, Suzhou Industrial Park, Jiangsu 215006, China

Tel:86-512-6917-5888

Fax:86-512-6917-5666

The test record, data evaluation & Equipment Under Test configurations represented herein are true and accurate accounts of the measurements of the samples EMC characteristics under the conditions specified in this report.

The above equipment was tested by CerpPASS Technology Corp. for compliance with the requirements of technical standards specified above under the EMC Directive **2014/30/EU**. The results of testing in this report apply only to the product/system, which was tested. Other similar equipment will not necessarily produce the same results due to production tolerance and measurement uncertainties

Approved by:

Miro Chueh
EMC/RF B.U. Manager

Laboratory Accreditation:

CerpPASS Technology Corporation Test Laboratory

NVLAP LAB Code:	200954-0
TAF LAB Code:	1439

CerpPASS Technology(SuZhou) Co., Ltd.

NVLAP LAB Code:	200814-0
CNAS LAB Code:	L5515



Contents

1. Summary of Test Procedure and Test Results	6
2. Immunity Testing Performance Criteria Definition	8
3. Test Configuration of Equipment under Test	9
3.1. Feature of Equipment under Test	9
3.2. Test Manner	9
3.3. Description of Support Unit	10
3.4. General Information of Test	11
3.5. Measurement Uncertainty	12
4. Test of Conducted Emission	14
4.1. Test Limit	14
4.2. Test Procedures	15
4.3. Typical Test Setup	15
4.4. Measurement Equipment	16
4.5. Test Result and Data	17
4.6. Test Photographs of Power Port	22
4.7. Test Photographs of Telecommunication Port	23
5. Test of Radiated Emission	24
5.1. Test Limit	24
5.2. Test Procedures	25
5.3. Typical Test Setup	25
5.4. Measurement Equipment	26
5.5. Test Result and Data (30MHz ~ 1GHz)	27
5.6. Test Result and Data (1GHz ~ 6GHz)	29
5.7. Test Photographs (30MHz~1GHz)	31
5.8. Test Photographs (1GHz~6GHz)	32
6. Harmonics Test	33
6.1. Limits of Harmonics Current Measurement	33
6.2. Measurement equipment	34
6.3. Test Result and Data	35
6.4. Test Photographs	37
7. Voltage Fluctuations Test	38
7.1. Test Procedure	38
7.2. Measurement Equipment	38
7.3. Test Result and Data	39
7.4. Test Photographs	41
8. Electrostatic Discharge Immunity Test	42
8.1. Test Procedure	42
8.2. Test Setup for Tests Performed in Laboratory	43
8.3. Test Severity Levels	44
8.4. Measurement Equipment	44
8.5. Test Result and Data	45
8.6. Test Photographs	47
9. Radio Frequency electromagnetic field immunity test	50



- 9.1. Test Procedure 50
- 9.2. Test Severity Levels 50
- 9.3. TEST SETUP 51
- 9.4. Measurement Equipment..... 52
- 9.5. Test Result and Data..... 53
- 9.6. Test Photographs 55
- 10. Electrical Fast Transient/ Burst Immunity Test 56**
 - 10.1. Test Procedure 56
 - 10.2. Test Severity Levels 56
 - 10.3. TEST SETUP 57
 - 10.4. Measurement Equipment..... 58
 - 10.5. Test Result and Data..... 59
 - 10.6. Test Photographs 61
- 11. Surge Immunity Test..... 63**
 - 11.1. Test Procedure 63
 - 11.2. Test Severity Level 63
 - 11.3. TEST SETUP 64
 - 11.4. Measurement Equipment..... 64
 - 11.5. Test Result and Data..... 65
 - 11.6. Test Photographs 68
- 12. Conduction Disturbances induced by Radio-Frequency Fields 69**
 - 12.1. Test Procedure 69
 - 12.2. Test Severity Levels 69
 - 12.3. TEST SETUP 70
 - 12.4. Measurement Equipment..... 70
 - 12.5. Test Result and Data..... 71
 - 12.6. Test Photographs 73
- 13. Power Frequency Magnetic Field Immunity Test..... 74**
 - 13.1. Test Setup 74
 - 13.2. Test Severity Levels 74
 - 13.3. Measurement Equipment..... 74
 - 13.4. Test Result and Data..... 75
 - 13.5. Test Photographs 76
- 14. Voltage Dips and Voltage Interruptions Immunity Test Setup 77**
 - 14.1. Test Conditions..... 77
 - 14.2. TEST SETUP 77
 - 14.3. Measurement Equipment..... 77
 - 14.4. Test Result and Data..... 78
- 15. EUT Photographs 79**



1. Summary of Test Procedure and Test Results

EMISSION[EN 55022: 2010/AC:2011]			
Standard	Item	Result	Remarks
EN55022: 2010/AC:2011	Conducted (Power Port)	PASS	Meet Class B Limit Minimum passing margin(AV) is -2.14 dB at 0.3339 MHz
	Conducted (Telecom port)	PASS	Meets Class B Limit Minimum passing margin(AV) is -2.37 dB at 0.3220 MHz
	Radiated	PASS	Meets Class B Limit Minimum passing margin(QP) is -3.67 dB at 84.3200 MHz
EN 61000-3-2: 2014	Harmonic current emissions	PASS	Meet Class A Limit
EN61000-3-3:2013	Voltage fluctuations & flicker	PASS	Meets the requirements

IMMUNITY[EN 55024:2010]			
Standard	Item	Result	Remarks
IEC 61000-4-2: 2008	ESD	PASS	Meets the requirements of Performance Criterion A
IEC 61000-4-3: 2006+A1:2007+A2:2010	RS	PASS	Meets the requirements of Performance Criterion A
IEC 61000-4-4: 2012	EFT	PASS	Meets the requirements of Performance Criterion A
IEC 61000-4-5:2005	Surge	PASS	Meets the requirements of Performance Criterion A
IEC 61000-4-6:2008	CS	PASS	Meets the requirements of Performance Criterion A
IEC 61000-4-8:2009	PFMF	PASS	Meets the requirements of Performance Criterion A
IEC 61000-4-11:2004	Voltage dips & voltage variations	N/A	N/A



IMMUNITY[EN 50130-4: 2011]			
Standard	Item	Result	Remarks
IEC 61000-4-2: 2008	ESD	PASS	Meets the requirements of Performance Criterion A
IEC 61000-4-3: 2006+A1:2007+A2:2010	RS	PASS	Meets the requirements of Performance Criterion A
IEC 61000-4-4: 2012	EFT	PASS	Meets the requirements of Performance Criterion A
IEC 61000-4-5:2005	Surge	PASS	Meets the requirements of Performance Criterion A
IEC 61000-4-6:2008	CS	PASS	Meets the requirements of Performance Criterion A
IEC 61000-4-11:2004	Voltage dips & voltage variations	N/A	N/A



2. Immunity Testing Performance Criteria Definition

- A. Normal performance within limits specified by the manufacture, requestor or purchaser;
- B. Temporary loss of function or degradation of performance which ceases after the disturbance ceases, and from which the equipment under test recovers its normal performance, without operator intervention;
- C. Temporary loss of function or degradation of performance, the correction of which requires operation intervention;
- D. Loss of function or degradation of performance which is not recoverable, owing to damage to hardware or software, or loss of data.



3. Test Configuration of Equipment under Test

3.1. Feature of Equipment under Test

Product Name:	Network Bullet Camera	
Model Name:	PI-SPW403L	
Adapter	Model No.:	ADS-12B-12 12012Gz
	INPUT:	100-240V~ 50/60Hz 0.3A Max.
	OUTPUT:	12V, 1.0A

Note: Please refer to user manual.

I/O PORT:

I/O PORT TYPE	Quantity
1). RJ45 Port	1

3.2. Test Manner

- a. During testing, the interface cables and equipment positions were varied according to Europe Standard EN55022 Class B.
- b. Turn on the power of all equipment.
- c. The complete test system included Notebook PC and EUT for EMI&EMS test.
- d. The test mode as follow(CE):
 - Test Mode 1. Normal Operation
 - Test Mode 2. Normal Operation for POE Mode
 - The "Test Mode 1,2" were reported as final data.
- e. The test mode as follow(RE/H&F/EMS):
 - Test Mode 1. Normal Operation
 - The "Test Mode 1" were reported as final data.
- f. The maximum operating frequency is above 108MHz, the test frequency range is from 1GHz to 6GHz.



3.3. Description of Support Unit

EMI & EMS:

No	Device	Manufacturer	Model No.	Description
1	Notebook PC	SONY	PCG-71811P	Non-Shielded,1.5m (R33021)

Use Cable:

No	Cable	Quantity	Description
A	LAN Cable	1	Non-Shielded>3.0 m



3.4. General Information of Test

<input type="checkbox"/>	Test Site	<p>CerpPASS Technology Corporation Test Laboratory Address: No.10, Ln. 2, Lianfu St., Luzhu Dist., Taoyuan City 33848, Taiwan (R.O.C.) Tel:+886-3-3226-888 Fax:+886-3-3226-881 Address: No.68-1, Shihbachongsi, Shihding Township, New Taipei City 223, Taiwan, R.O.C. Tel: +886-2-2663-8582</p>
	FCC	TW1079, TW1061,390316, 228391, 641184
	IC	4934B-1, 4934E-1, 4934E-2
	VCCI	T-2205 for Telecommunication Test C-4663 for Conducted emission test R-3428, R-4218 for Radiated emission test G-812, G-813 for radiated disturbance above 1GHz
<input checked="" type="checkbox"/>	Test Site	<p>CerpPASS Technology (Suzhou) Co.,Ltd Address: No.66,Tangzhuang Road, Suzhou Industrial Park, Jiangsu 215006, China Tel: +86-512-6917-5888 Fax: +86-512-6917-5666</p>
	FCC	331395
	IC	7290A-1, 7290A-2
	VCCI	T-1945 for Telecommunication Test C-2919 for Conducted emission test R-2670 for Radiated emission test G-227 for radiated disturbance above 1GHz
Frequency Range Investigated:		Conducted: from 150kHz to 30 MHz Radiation: from 30 MHz to 6000MHz
Test Distance :		The test distance of radiated emission below 1GHz from antenna to EUT is 10 M. The test distance of radiated emission above 1GHz from antenna to EUT is 3 M.



3.5. Measurement Uncertainty

Where relevant, the following measurement uncertainty levels have been estimated for tests performed on the EUT as specified in CISPR 16-4-2:

Measurement	Frequency	Uncertainty
Conducted emissions(LINE)	0.09MHz-30MHz	+/- 0.6888 dB
Conducted emissions(NEUTRAL)	0.09MHz-30MHz	+/- 0.7002 dB

Measurement	Polarity	Frequency	Uncertainty
Radiated emissions (below 1GHz)	H	30MHz ~ 200MHz	+/- 4.0677dB
		200MHz ~1000MHz	+/- 3.9131dB
	V	30MHz ~ 200MHz	+/- 4.0678dB
		200MHz ~1000MHz	+/- 3.9142dB
Radiated emissions (above 1GHz)	H	1000MHz ~18000MHz	+/- 3.8904 dB
		18000MHz ~40000MHz	+/-3.9356dB
	V	1000MHz ~18000MHz	+/- 3.8896dB
		18000MHz ~40000MHz	+/- 3.8766dB

Measurement	Uncertainty
ESD—Rise time tr	6.4%
ESD—Peak current Ip	6%
ESD—Current at 30 ns	6%
ESD—Current at 60 ns	6%
ESD- Charging voltage	1%
RS above 1GHz	±2.28dB
RS under 1GHz	±3.62dB
EFT—Rise time tr	4%
EFT—Peak current Ip	4%
EFT—Current	4%
Surge—Rise time tr	4%
Surge—Peak current Ip	4%



Surge—Current	4%
CS-CND	±0.80dB
CS-Clamp	±1.06dB

This uncertainty represents an expanded uncertainty expressed at approximately the 95% confidence level using a coverage factor of k=2.

Consistent with industry standard (e.g. CISPR 22: 2008, clause 11, Measurement Uncertainty) determining compliance with the limits shall be base on the results of the compliance measurement. Consequently the measure emissions being less than the maximum allowed emission result in this be a compliant test or passing test.



4. Test of Conducted Emission

4.1. Test Limit

Conducted Emissions were measured from 150 kHz to 30 MHz with a bandwidth of 9 kHz and return leads of the EUT according to the methods defined in European Standard EN 55022. The EUT was placed on a nonmetallic stand in a shielded room 0.8 meters above the ground plane as shown in section 4.2. The interface cables and equipment positioning were varied within limits of reasonable applications to determine the position producing maximum conducted emissions.

Table 1 Conducted Emission Limits (dB μ V):

Frequency range (MHz)	Class A Equipment		Class B Equipment	
	Quasi Peak	Average	Quasi Peak	Average
0.15 to 0.50	79	66	66 to 56	56 to 46
0.50 to 5	73	60	56	46
5. to 30.	73	60	60	50

Note 1: The lower limits shall apply at the transition frequencies.
 Note 2: The limit decreases linearly with the logarithm of the frequency in the range 0.15 MHz to 0.5MHz.

Table 2 - Limits of conducted common mode (asymmetric mode) disturbance at telecommunication ports in the frequency range 0.15 MHz to 30 MHz(dB(μ V)).

Frequency range (MHz)	Class A Equipment				Class B Equipment			
	Voltage		Current		Voltage		Current	
	Quasi Peak	Avg.	Quasi Peak	Avg.	Quasi Peak	Avg.	Quasi Peak	Avg.
0.15 to 0.5	97~ 87	84~74	53~43	40~30	84~74	74~64	40~30	30~20
0.5 to 5	87	74	43	30	74	64	30	20
5 to 30	87	74	43	30	74	64	30	20

Note 1: The limits decrease linearly with the logarithm of the frequency in the range 0.15 to 0.5 MHz.
 Note 2 : The current and voltage disturbance limits are derived for use with an impedance stabilization network (ISN) which presents a common mode (asymmetric mode) impedance of 150 Ω to the telecommunication under test (conversion factor is $20 \log_{10} 150/1 = 44\text{dB}$).

4.2. Test Procedures

- a. The EUT was placed on a desk 0.8 meters height from the metal ground plane and 0.4 meter from the conducting wall of the shielding room and it was kept at least 0.8 meters from any other grounded conducting surface.
- b. Connect EUT to the power mains through a line impedance stabilization network (LISN).
- c. All the support units are connecting to the other LISN.
- d. The LISN provides 50 ohm coupling impedance for the measuring instrument.
- e. The CISPR states that a 50 ohm, 50 micro-Henry LISN should be used.
- f. Both sides of AC line were checked for maximum conducted interference.
- g. The frequency range from 150 kHz to 30 MHz was searched
- h. Set the test-receiver system to Peak Detect Function and Specified Bandwidth with Maximum Hold Mode.

4.3. Typical Test Setup

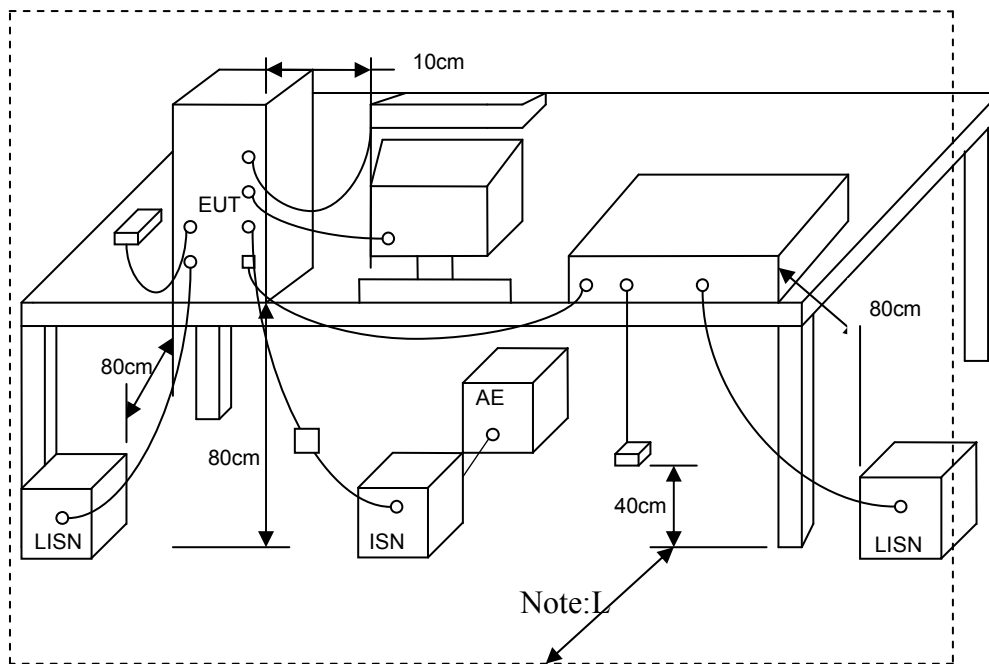



4.4. Measurement Equipment

Instrument/Ancillary	Manufacturer	Model No.	Serial No.	Calibration Date	Valid Date.
Test Receiver	R&S	ESCI	100565	2015.03.29	2016.03.28
AMN	R&S	ESH2-Z5	100182	2014.09.04	2015.09.03
Two-Line V-Network	R&S	ENV216	100325	/	/
ISN	FCC	FCC-TLISN-T2-02	20379	2015.03.29	2016.03.28
ISN	FCC	FCC-TLISN-T4-02	20380	2015.03.29	2016.03.28
ISN	FCC	FCC-TLISN-T8-02	20381	2015.03.29	2016.03.28
ISN	TESEQ	ISN ST08	30175	2015.03.29	2016.03.28
Current Probe	R&S	EZ-17	100303	2015.03.29	2016.03.28
Passive Voltage Probe	R&S	ESH2-Z3	100026	2015.03.29	2016.03.28
Pulse Limiter	R&S	ESH3-Z2	100529	2015.03.29	2016.03.28
Temperature/ Humidity Meter	Zhicheng	ZC1-11	CEP-TH-004	2015.04.02	2016.04.01
EZ-EMC	Fala	Ver CT3A1	N/A	N/A	N/A



4.5. Test Result and Data

4.5.1 Conducted Emission for Power Port Test Data

Test Mode :	Mode 1: Normal Operation		
AC Power :	AC 230V/50Hz	Phase :	LINE
Equipment :	Network Bullet Camera	Model No :	PI-SPW403L
Temperature :	24°C	Humidity :	53%
Pressure(mbar) :	1002	Date :	2015/05/22

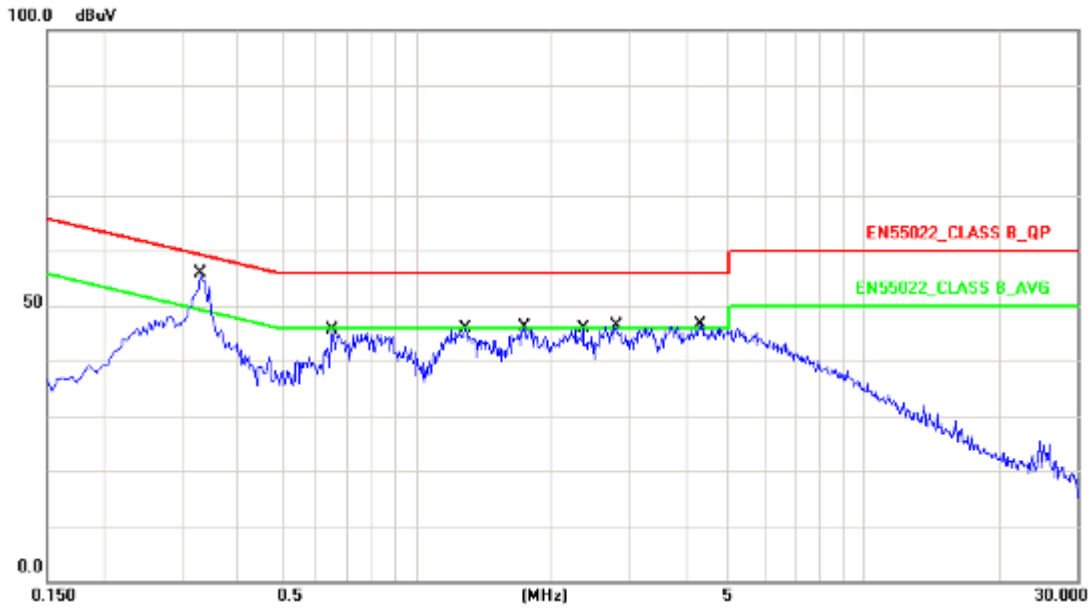

No.	Frequency (MHz)	Factor (dB)	Reading (dBuV)	Level (dBuV)	Limit (dBuV)	Margin (dB)	Detector
1	0.3300	10.27	41.85	52.12	59.45	-7.33	QP
2	0.3300	10.27	29.72	39.99	49.45	-9.46	AVG
3	0.6500	10.31	30.99	41.30	56.00	-14.70	QP
4	0.6500	10.31	17.85	28.16	46.00	-17.84	AVG
5	1.2940	10.30	31.12	41.42	56.00	-14.58	QP
6	1.2940	10.30	20.06	30.36	46.00	-15.64	AVG
7	1.7460	10.30	30.85	41.15	56.00	-14.85	QP
8	1.7460	10.30	19.67	29.97	46.00	-16.03	AVG
9	2.3699	10.30	29.20	39.50	56.00	-16.50	QP
10	2.3699	10.30	18.21	28.51	46.00	-17.49	AVG
11	2.8020	10.30	29.90	40.20	56.00	-15.80	QP
12	2.8020	10.30	19.05	29.35	46.00	-16.65	AVG
13	4.3260	10.29	30.07	40.36	56.00	-15.64	QP
14	4.3260	10.29	18.33	28.62	46.00	-17.38	AVG

Note: Measurement Level = Reading Level + Correct Factor



Test Mode :	Mode 1: Normal Operation		
AC Power :	AC 230V/50Hz	Phase :	NEUTRAL
Equipment :	Network Bullet Camera	Model No :	PI-SPW403L
Temperature :	24°C	Humidity :	53%
Pressure(mbar) :	1002	Date :	2015/05/22

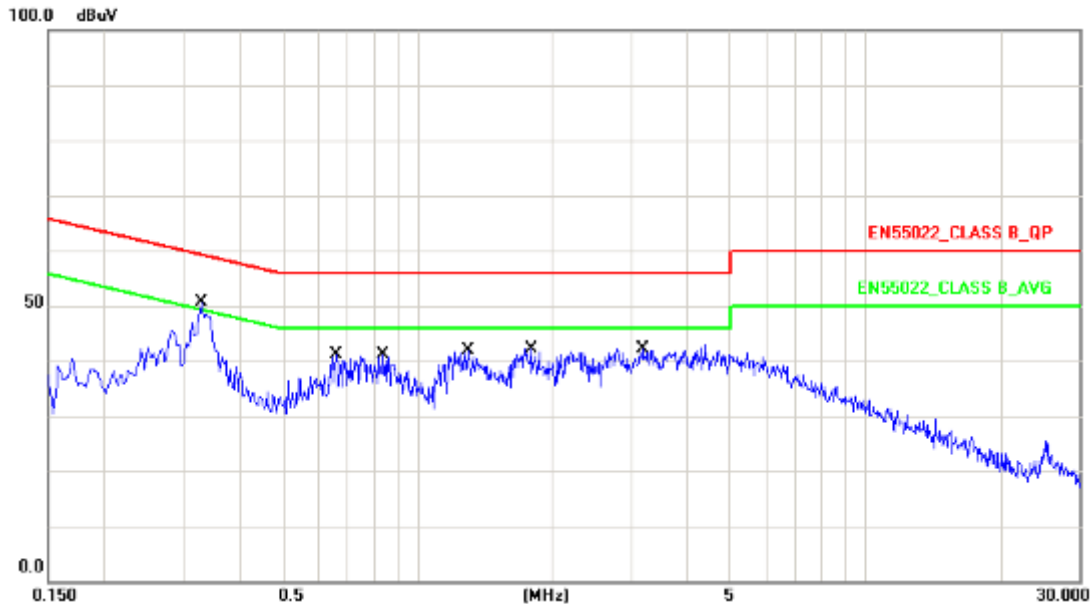

No.	Frequency (MHz)	Factor (dB)	Reading (dBuV)	Level (dBuV)	Limit (dBuV)	Margin (dB)	Detector
1	0.3300	10.24	35.40	45.64	59.45	-13.81	QP
2	0.3300	10.24	23.28	33.52	49.45	-15.93	AVG
3	0.6580	10.27	25.26	35.53	56.00	-20.47	QP
4	0.6580	10.27	13.46	23.73	46.00	-22.27	AVG
5	0.8420	10.30	25.00	35.30	56.00	-20.70	QP
6	0.8420	10.30	14.31	24.61	46.00	-21.39	AVG
7	1.2980	10.40	25.39	35.79	56.00	-20.21	QP
8	1.2980	10.40	14.36	24.76	46.00	-21.24	AVG
9	1.7940	10.47	24.78	35.25	56.00	-20.75	QP
10	1.7940	10.47	13.83	24.30	46.00	-21.70	AVG
11	3.1820	10.51	24.55	35.06	56.00	-20.94	QP
12	3.1820	10.51	13.38	23.89	46.00	-22.11	AVG

Note: Measurement Level = Reading Level + Correct Factor



Test Mode :	Mode 2: Normal Operation for POE Mode		
DC Power :	DC 48V	Phase :	POE
Equipment :	Network Bullet Camera	Model No :	PI-SPW403L
Temperature :	24°C	Humidity :	53%
Pressure(mbar) :	1002	Date :	2015/05/22

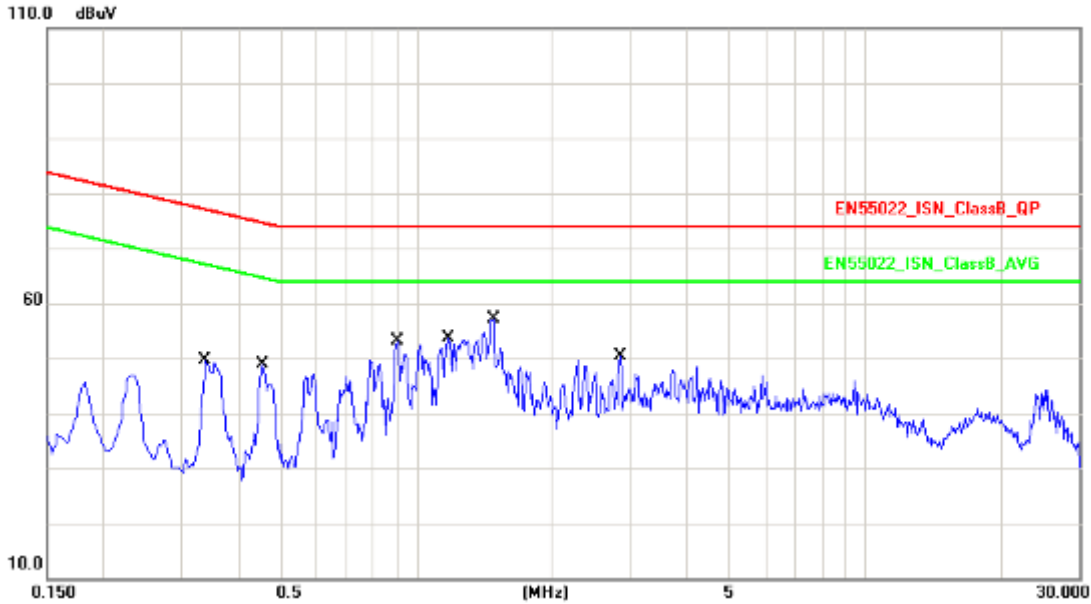

No.	Frequency (MHz)	Factor (dB)	Reading (dBuV)	Level (dBuV)	Limit (dBuV)	Margin (dB)	Detector
1	0.3379	19.62	26.89	46.51	78.63	-32.12	QP
2	0.3379	19.62	18.65	38.27	68.63	-30.36	AVG
3	0.4540	19.60	27.51	47.11	75.31	-28.20	QP
4	0.4540	19.60	18.34	37.94	65.31	-27.37	AVG
5	0.9060	19.38	31.89	51.27	74.00	-22.73	QP
6	0.9060	19.38	21.14	40.52	64.00	-23.48	AVG
7	1.1740	19.28	32.40	51.68	74.00	-22.32	QP
8	1.1740	19.28	22.05	41.33	64.00	-22.67	AVG
9	1.4860	19.25	25.70	44.95	74.00	-29.05	QP
10	1.4860	19.25	17.98	37.23	64.00	-26.77	AVG
11	2.8460	19.34	22.30	41.64	74.00	-32.36	QP
12	2.8460	19.34	12.33	31.67	64.00	-32.33	AVG

Note: Measurement Level = Reading Level + Correct Factor

Test engineer: Seben



4.5.2 Conducted Emission for Telecommunication Port Test Data

Test Mode :	Mode 1: Normal Operation		
AC Power :	AC 230V/50Hz	Phase :	10M
Equipment :	Network Bullet Camera	Model No :	PI-SPW403L
Temperature :	24°C	Humidity :	53%
Pressure(mbar) :	1002	Date :	2015/05/22

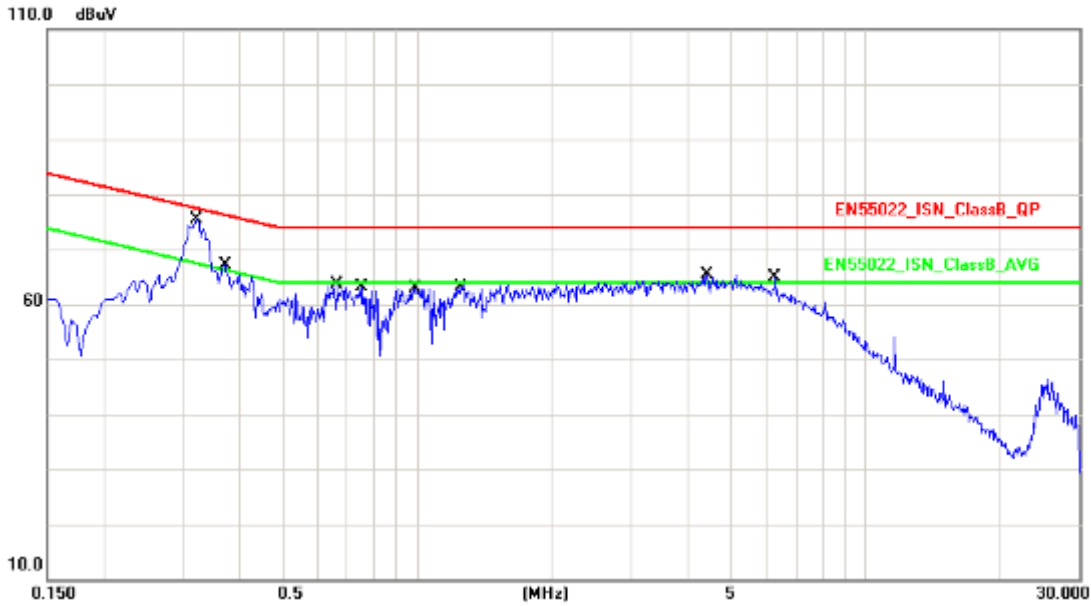

No.	Frequency (MHz)	Factor (dB)	Reading (dBuV)	Level (dBuV)	Limit (dBuV)	Margin (dB)	Detector
1	0.3220	19.62	54.25	73.87	79.08	-5.21	QP
2	0.3220	19.62	45.67	65.29	69.08	-3.79	AVG
3	0.3740	19.61	45.97	65.58	77.60	-12.02	QP
4	0.3740	19.61	37.27	56.88	67.60	-10.72	AVG
5	0.6660	19.57	41.47	61.04	74.00	-12.96	QP
6	0.6660	19.57	31.54	51.11	64.00	-12.89	AVG
7	0.7580	19.50	39.89	59.39	74.00	-14.61	QP
8	0.7580	19.50	29.72	49.22	64.00	-14.78	AVG
9	0.9900	19.31	40.56	59.87	74.00	-14.13	QP
10	0.9900	19.31	31.57	50.88	64.00	-13.12	AVG
11	1.2500	19.27	40.84	60.11	74.00	-13.89	QP
12	1.2500	19.27	31.66	50.93	64.00	-13.07	AVG
13	4.4500	19.61	39.45	59.06	74.00	-14.94	QP
14	4.4500	19.61	30.84	50.45	64.00	-13.55	AVG
15	6.3060	19.49	38.88	58.37	74.00	-15.63	QP
16	6.3060	19.49	31.44	50.93	64.00	-13.07	AVG

Note: Measurement Level = Reading Level + Correct Factor



Test Mode :	Mode 1: Normal Operation		
AC Power :	AC 230V/50Hz	Phase :	100M
Equipment :	Network Bullet Camera	Model No :	PI-SPW403L
Temperature :	24°C	Humidity :	53%
Pressure(mbar) :	1002	Date :	2015/05/22

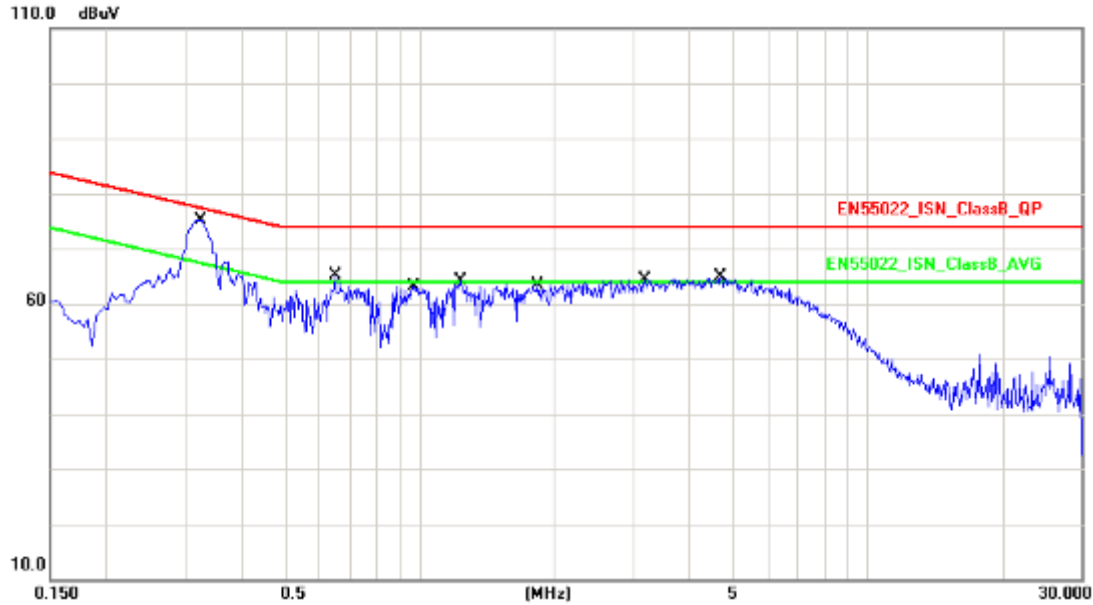

No.	Frequency (MHz)	Factor (dB)	Reading (dBuV)	Level (dBuV)	Limit (dBuV)	Margin (dB)	Detector
1	0.3260	19.62	53.84	73.46	78.97	-5.51	QP
2	0.3260	19.62	44.68	64.30	68.97	-4.67	AVG
3	0.6500	19.57	40.63	60.20	74.00	-13.80	QP
4	0.6500	19.57	29.32	48.89	64.00	-15.11	AVG
5	0.9700	19.32	40.33	59.65	74.00	-14.35	QP
6	0.9700	19.32	31.17	50.49	64.00	-13.51	AVG
7	1.2380	19.27	40.85	60.12	74.00	-13.88	QP
8	1.2380	19.27	31.76	51.03	64.00	-12.97	AVG
9	1.8420	19.21	39.75	58.96	74.00	-15.04	QP
10	1.8420	19.21	30.27	49.48	64.00	-14.52	AVG
11	3.2020	19.40	39.86	59.26	74.00	-14.74	QP
12	3.2020	19.40	30.54	49.94	64.00	-14.06	AVG
13	4.6979	19.65	39.39	59.04	74.00	-14.96	QP
14	4.6979	19.65	30.49	50.14	64.00	-13.86	AVG

Note: Measurement Level = Reading Level + Correct Factor

Test engineer: Seben



4.6. Test Photographs of Power Port

Front View



Rear View





4.7. Test Photographs of Telecommunication Port

LAN

Front View



Rear View





5. Test of Radiated Emission

5.1. Test Limit

The EUT shall meet the limits of below Table when measured at the measuring distance R in accordance with the methods described in European Standard EN 55022 Clause 10. If the reading on the measuring receiver shows fluctuations close to the limit, the reading shall be observed for at least 15 s at each measurement frequency; the highest reading shall be recorded, with the exception of any brief isolated high reading, which shall be ignored.

Table 1 – Limits for radiated disturbance at a measuring distance of 10 m (dB(μV/m))

Frequency range(MHz)	Class A Equipment		Class B Equipment	
	Quasi-peak		Quasi-peak	
30 to 230	40		30	
230 to 1000	47		37	
NOTE 1 The lower limit shall apply at the transition frequency.				
NOTE 2 Additional provisions may be required for cases where interference occurs.				

The EUT shall meet the limits of below Table when measured in accordance with the method described in European Standard EN 55022 Clause 10 and the conditional testing procedure described below.

Table 2 – Limits for radiated disturbance at a measuring distance of 3 m (dB (μV/m))

Frequency range (MHz)	Class A Equipment		Class B Equipment	
	Avg.	Peak	Avg.	Peak
1 to 3	56	76	50	70
3 to 6	60	80	54	74
NOTE The lower limit applies at the transition frequency.				

• **Conditional testing procedure:**

The highest internal source of an EUT is defined as the highest frequency generated or used within the EUT or on which the EUT operates or tunes.

If the highest frequency of the internal sources of the EUT is less than 108 MHz, the measurement shall only be made up to 1 GHz.

If the highest frequency of the internal sources of the EUT is between 108 MHz and 500 MHz, the measurement shall only be made up to 2 GHz.

If the highest frequency of the internal sources of the EUT is between 500 MHz and 1 GHz, the measurement shall only be made up to 5 GHz.

If the highest frequency of the internal sources of the EUT is above 1 GHz, the measurement shall be made up to 5 times the highest frequency or 6 GHz, whichever is less.

5.2. Test Procedures

- a. The EUT was placed on a rotatable table top 0.8 meter above ground.
- b. The EUT was set 3/10 meters from the interference receiving antenna which was mounted on the top of a variable height antenna tower.
- c. The table was rotated 360 degrees to determine the position of the highest radiation.
- d. The antenna is a half wave dipole and its height is varied between one meter and four meters above ground to find the maximum value of the field strength both horizontal polarization and vertical polarization of the antenna are set to make the measurement.
- e. For each suspected emission the EUT was arranged to its worst case and then tune the antenna tower (from 1 M to 4 M) and turn table (from 0 degree to 360 degrees) to find the maximum reading.
- f. Set the test-receiver system to Peak Detect Function and specified bandwidth with Maximum Hold Mode.
- g. If the emission level of the EUT in peak mode was 3 dB lower than the limit specified, then testing will be stopped and peak values of EUT will be reported, otherwise, the emissions which do not have 3 dB margin will be repeated one by one using the quasi-peak method and reported.

5.3. Typical Test Setup

Below 1GHz Test Setup

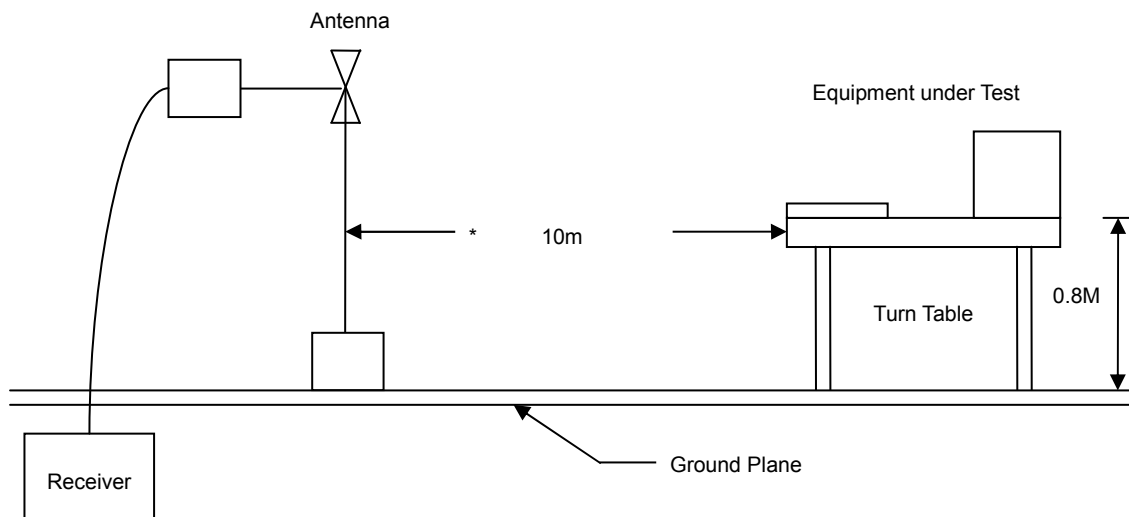

Above 1GHz Test Setup

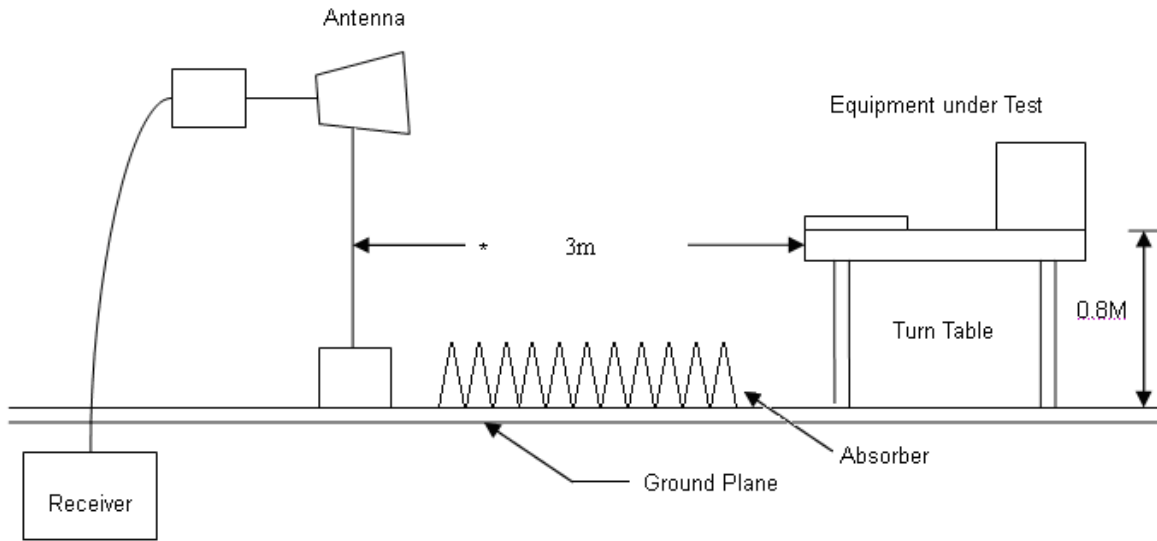

5.4. Measurement Equipment

Instrument/Ancillary	Manufacturer	Model No.	Serial No.	Calibration Date	Valid Date.
EMI Test Receiver	R&S	ESC17	100968	2014.06.11	2015.06.10
Preamplifier	Agilent	87405B	My39500554	2015.03.29	2016.03.28
Preamplifier	Agilent	8449B	3008A02342	2015.03.29	2016.03.28
Bilog Antenna	Sunol Science	JB1	A072414-3	2014.08.05	2015.08.04
Broad-Band Horn Antenna	Schwarzbeck	BBHA9120D	9120D-619	2015.04.20	2016.04.19
Spectrum Analyzer	R&S	FSP40	100324	2015.03.29	2016.03.28
Temperature/ Humidity Meter	Zhicheng	ZC1-11	CEP-TH-001	2015.04.02	2016.04.01
EZ-EMC	Fala	Ver CT3A1	N/A	N/A	N/A



5.5. Test Result and Data (30MHz ~ 1GHz)

Test Mode :	Mode 1: Normal Operation		
AC Power :	AC 230V/50Hz	Ant. Polarization:	Horizontal
Equipment :	Network Bullet Camera	Model No :	PI-SPW403L
Temp :	23°C	Humidity :	50%
Pressure(mbar) :	1002	Date :	2015/05/19

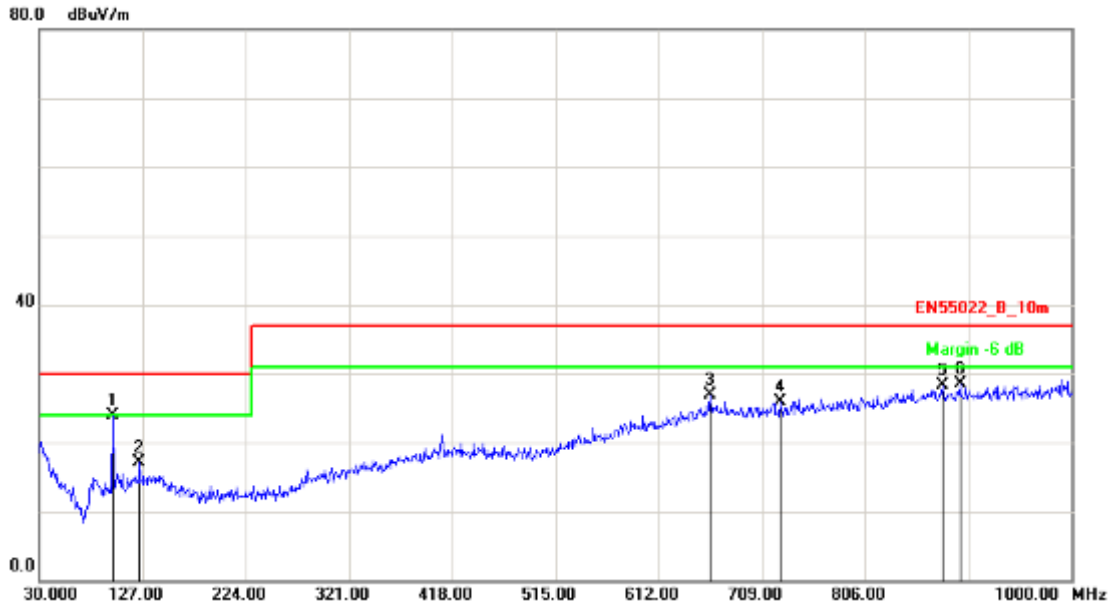

No.	Frequency (MHz)	Factor (dB/m)	Reading (dBuV)	Level (dBuV/m)	Limit (dBuV/m)	Margin (dB)	Det.	Height (cm)	Azimuth (deg)
1	98.8700	-13.06	36.94	23.88	30.00	-6.12	QP	265	0
2	124.0900	-9.82	26.91	17.09	30.00	-12.91	QP	100	304
3	660.5000	0.32	26.56	26.88	37.00	-10.12	QP	400	320
4	726.4600	0.27	25.70	25.97	37.00	-11.03	QP	233	0
5	878.7500	2.07	26.23	28.30	37.00	-8.70	QP	400	349
6	895.2400	2.20	26.27	28.47	37.00	-8.53	QP	400	132

Note: Measurement Level = Reading Level + Correct Factor



Test Mode :	Mode 1: Normal Operation		
AC Power :	AC 230V/50Hz	Ant. Polarization:	Vertical
Equipment :	Network Bullet Camera	Model No :	PI-SPW403L
Temp :	23°C	Humidity :	50%
Pressure(mbar) :	1002	Date :	2015/05/19

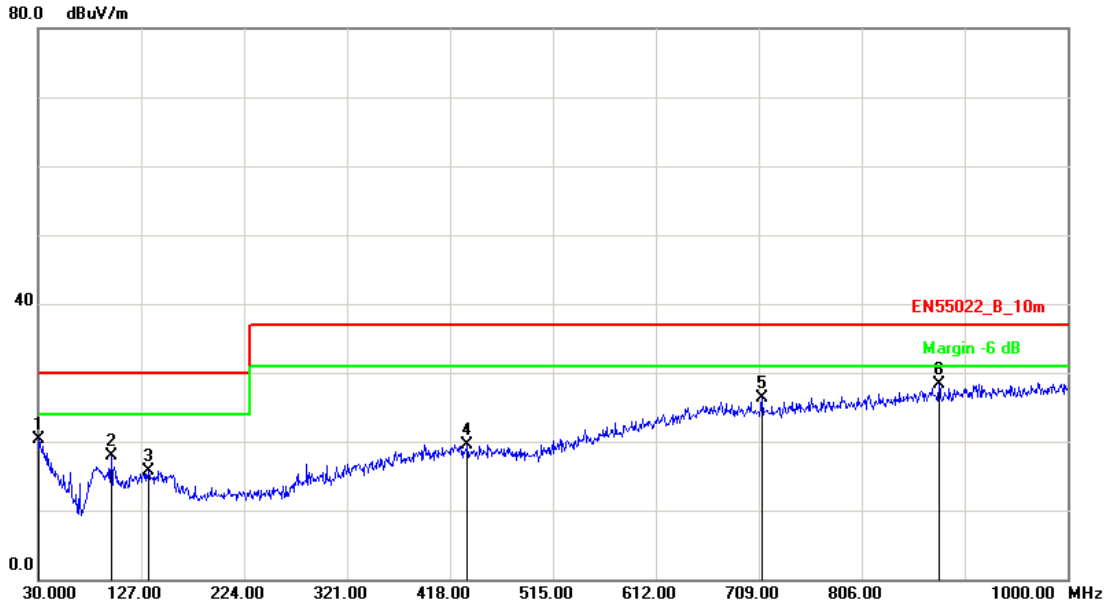

No.	Frequency (MHz)	Factor (dB/m)	Reading (dBuV)	Level (dBuV/m)	Limit (dBuV/m)	Margin (dB)	Det.	Height (cm)	Azimuth (deg)
1	30.9697	-5.75	26.14	20.39	30.00	-9.61	QP	100	123
2	98.8700	-13.06	30.89	17.83	30.00	-12.17	QP	100	9
3	133.7898	-9.83	25.61	15.78	30.00	-14.22	QP	100	48
4	434.4900	-5.37	24.89	19.52	37.00	-17.48	QP	400	119
5	711.9098	0.19	26.07	26.26	37.00	-10.74	QP	100	241
6	878.7500	2.08	26.20	28.28	37.00	-8.72	QP	400	152

Note: Measurement Level = Reading Level + Correct Factor

Test engineer: Seben



5.6. Test Result and Data (1GHz ~ 6GHz)

Test Mode :	Mode 1: Normal Operation		
AC Power :	AC 230V/50Hz	Ant. Polarization:	Horizontal
Equipment :	Network Bullet Camera	Model No :	PI-SPW403L
Temp :	23°C	Humidity :	50%
Pressure(mbar) :	1002	Date :	2015/05/19

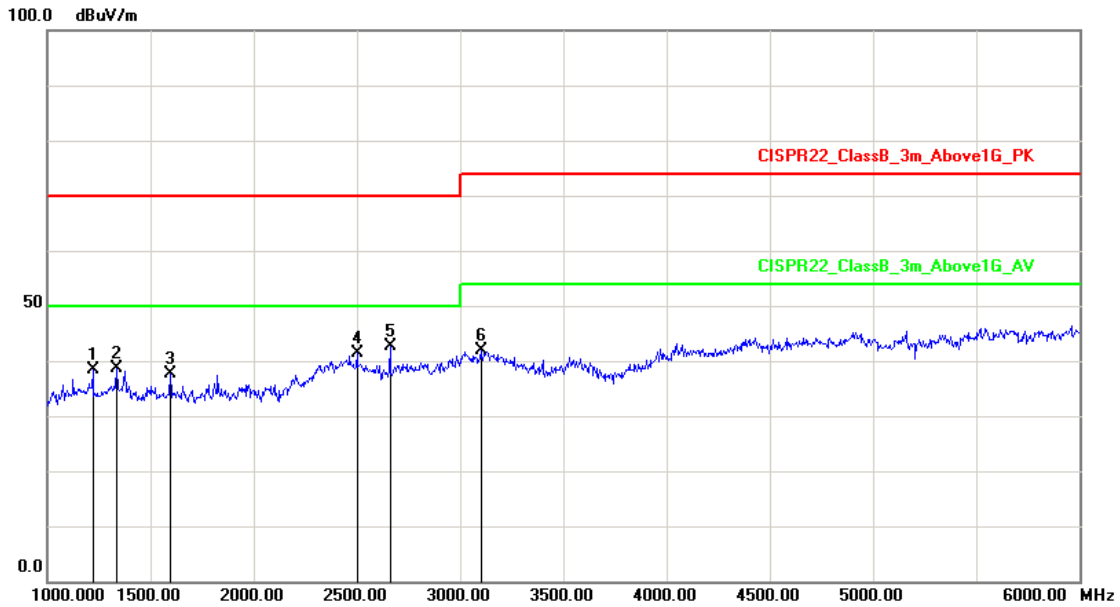

No.	Frequency (MHz)	Factor (dB/m)	Reading (dBuV)	Level (dBuV/m)	Limit (dBuV/m)	Margin (dB)	Det.	Height (cm)	Azimuth (deg)
1	1220.000	-14.29	52.66	38.37	70.00	-31.63	peak	400	349
2	1335.000	-13.11	51.66	38.55	70.00	-31.45	peak	300	255
3	1595.000	-12.02	49.59	37.57	70.00	-32.43	peak	200	137
4	2500.000	-3.86	45.31	41.45	70.00	-28.55	peak	200	90
5	2660.000	-4.68	47.25	42.57	70.00	-27.43	peak	100	184
6	3100.000	-2.37	44.33	41.96	74.00	-32.04	peak	100	0

Note: Measurement Level = Reading Level + Correct Factor



Test Mode :	Mode 1: Normal Operation		
AC Power :	AC 230V/50Hz	Ant. Polarization:	Vertical
Equipment :	Network Bullet Camera	Model No :	PI-SPW403L
Temp :	23°C	Humidity :	50%
Pressure(mbar) :	1002	Date :	2015/05/19

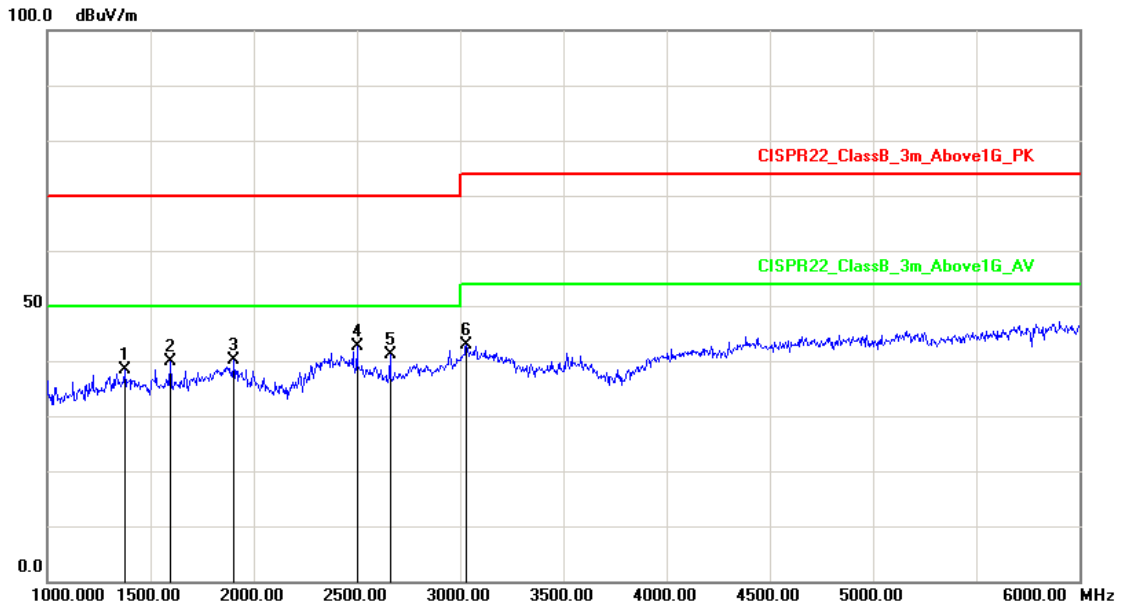

No.	Frequency (MHz)	Factor (dB/m)	Reading (dBuV)	Level (dBuV/m)	Limit (dBuV/m)	Margin (dB)	Det.	Height (cm)	Azimuth (deg)
1	1375.000	-12.83	51.31	38.48	70.00	-31.52	peak	100	169
2	1595.000	-12.02	51.78	39.76	70.00	-30.24	peak	300	226
3	1905.000	-9.79	49.86	40.07	70.00	-29.93	peak	100	318
4	2500.000	-3.86	46.60	42.74	70.00	-27.26	peak	100	6
5	2660.000	-4.68	45.86	41.18	70.00	-28.82	peak	100	10
6	3030.000	-2.54	45.49	42.95	74.00	-31.05	peak	200	214

Note: Measurement Level = Reading Level + Correct Factor

Test engineer: Seben



5.7. Test Photographs (30MHz~1GHz)

Front View



Rear View

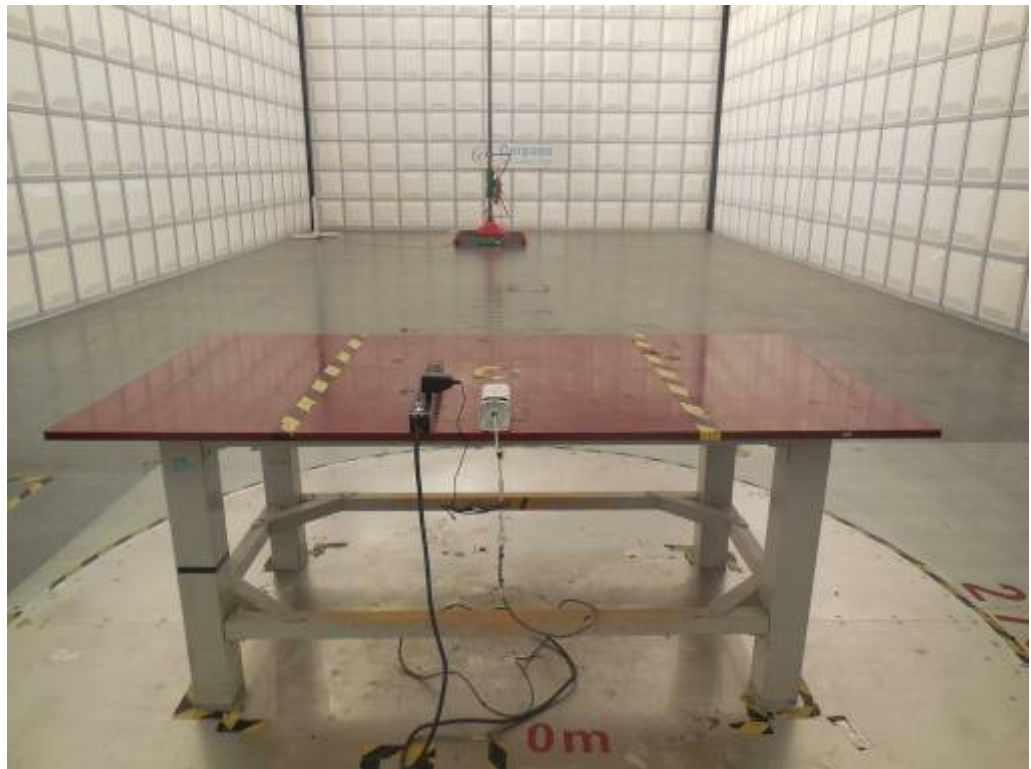



5.8. Test Photographs (1GHz~6GHz)

Front View



Rear View

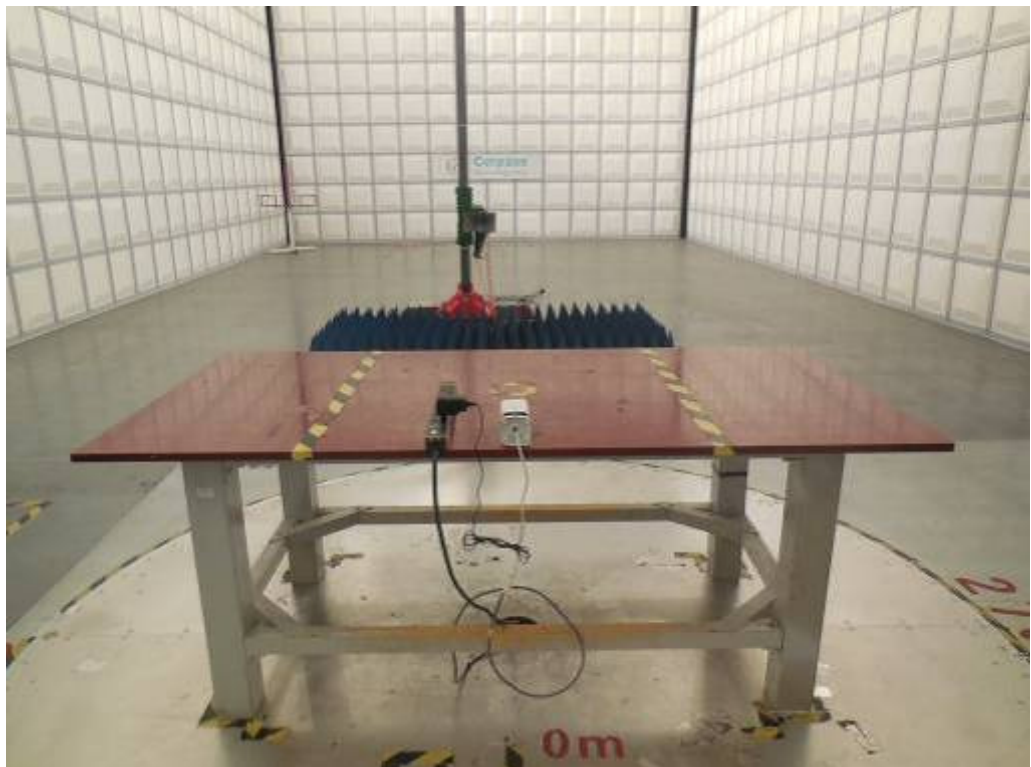



6. Harmonics Test

6.1. Limits of Harmonics Current Measurement

Limits for Class A equipment

Harmonics Order n	Max. permissible harmonics current A	Harmonics Order n	Max. permissible harmonics current A
Odd harmonics		Even harmonics	
3	2.30	2	1.08
5	1.14	4	0.43
7	0.77	6	0.30
9	0.40	8 ≤ n ≤ 40	0.23x8/n
11	0.33		
13	0.21		
15 ≤ n ≤ 39	0.15x15/n		

(b) Limits for Class B equipment

For Class B equipment, the harmonics of the input current shall not exceed the values given in Table that is the limit of Class A multiplied by a factor of 1,5.

(c) Limits for Class C equipment

Harmonics Order n	Maximum permissible harmonic current expressed as a percentage of the input current at the fundamental frequency %
2	2
3	$30 \cdot \lambda^*$
5	10
7	7
9	5
11 < n < 39 (odd harmonics only)	3

* λ is the circuit power factor

(d) Limits for Class D equipment

Harmonics Order n	Maximum permissible harmonic current per watt mA/W	Maximum permissible harmonic current A
3	3.4	2.30
5	1.9	1.14
7	1.0	0.77
9	0.5	0.40
11	0.35	0.33
11 < n < 39 (odd harmonics only)	3.85/n	See limit of Class A

NOTE: According to section 7 of EN 61000-3-2, the above limits for all equipment except for lighting equipment having an active input power > 75 W and no limits apply for equipment with an active input power up to and including 75 W.



6.2. Measurement equipment

Instrument/Ancillary	Manufacturer	Model No.	Serial No.	Calibration Date	Valid Date.
EMC Emission Tester	EMCPARTNER	Harmonics-1000	159	2015.04.02	2016.04.01
Temperature/ Humidity Meter	Zhicheng	ZC1-11	CEP-TH-004	2015.04.02	2016.04.01
POWER SOURCE	Pacific	140AMX-UP12/S	1792	2014.09.04	2015.09.03
HARCS	EMC Partner AG	Ver 4.18	N/A	N/A	N/A



6.3. Test Result and Data

Basic Standard	:	EN 61000-3-2
Final Test Result	:	PASS
Test Mode	:	Mode 1
Equipment	:	Network Bullet Camera
Model No.	:	PI-SPW403L
Temperature	:	22°C
Humidity	:	49%
Atmospheric Pressure	:	100 kPa
Test Date	:	May 19, 2015

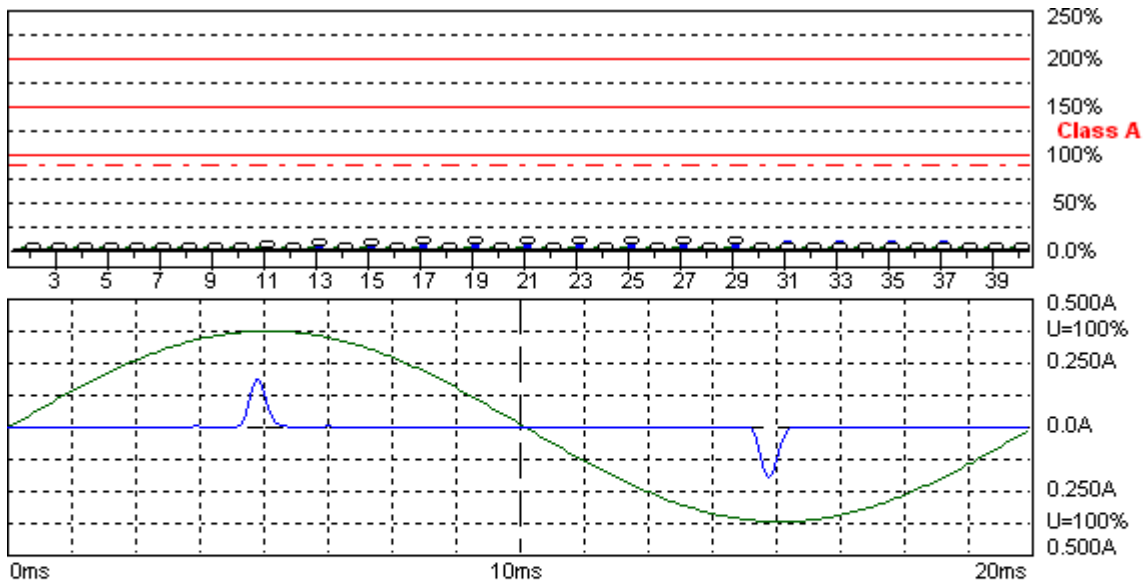

Harmonic Emission - IEC 61000-3-2 , EN 61000-3-2 , (EN60555-2)

2015-5-19 17:13:04 harmonic.hsu

Urms = 229.9 V P = 2.601 W THC = 0.033 A
 Irms = 0.032 A pf = 0.351

Range: 0.5 A
 V-nom: 230 V
 TestTime: 15 min (100%)

IPC-HFW4421EP
 MODE3

Test completed, Result: PASSED

HAR-1000 EMC-Partner

Full Bar : Actual Values

Empty Bar : Maximum Values

Blue : Current , Green : Voltage , Red : Failed

Urms = 229.9V Freq = 50.013 Range: 0.5 A

Irms = 0.032A Ipk = 0.204A cf = 6.326

P = 2.601W S = 7.409VA pf = 0.351

THDi = 94.4 % THDu = 0.20 % Class A

Test - Time : 15min (100 %)

Test completed, Result: PASSED



6.4. Test Photographs





7. Voltage Fluctuations Test

7.1. Test Procedure

The equipment shall be tested under the conditions of **Clause 5**.

The total impedance of the test circuit, excluding the appliance under test, but including the internal impedance of the supply source, shall be equal to the reference impedance.

The stability and tolerance of the reference impedance shall be adequate to ensure that the overall accuracy of $\pm 8\%$ is achieved during the whole assessment procedure.

7.2. Measurement Equipment

Instrument	Manufacturer	Model No.	Serial No.	Calibration Date	Valid Date
EMC Emission Tester	EMCPARTNER	Harmonics-1000	159	2015.04.02	2016.04.01
Temperature/ Humidity Meter	Zhicheng	ZC1-11	CEP-TH-004	2015.04.02	2016.04.01
POWER SOURCE	Pacific	140AMX-UP12/S	1792	2014.09.04	2015.09.03
HARCS	EMC Partner AG	Ver 4.18	N/A	N/A	N/A



7.3. Test Result and Data

Basic Standard	:	EN 61000-3-3
Final Test Result	:	PASS
Test Mode	:	Mode 1
Equipment	:	Network Bullet Camera
Model No.	:	PI-SPW403L
Temperature	:	22°C
Humidity	:	49%
Atmospheric Pressure	:	100 kPa
Test Date	:	May 19, 2015

Flickermeter 1000-4-15 for 230V/50Hz

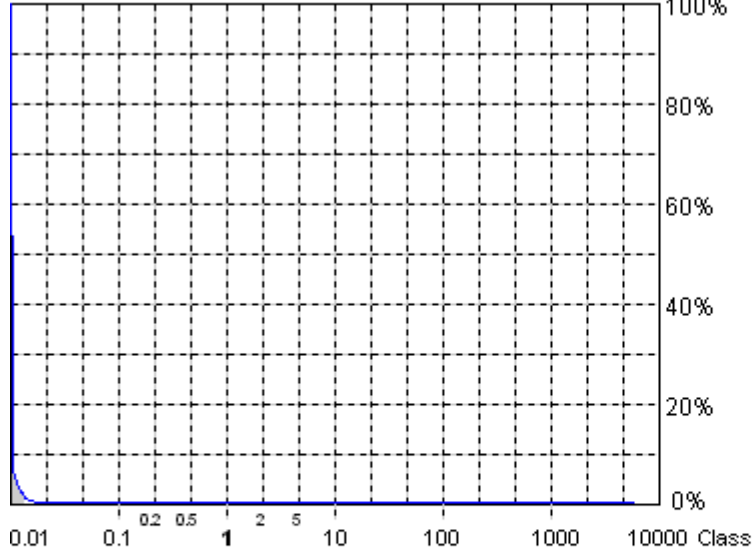

Actual Flicker (Fli): 0.01
Short-term Flicker (Pst): 0.07
 Limit (Pst): 1.00
Long-term Flicker (Plt): 0.07
 Limit (Plt): 0.65
Maximum Relative Volt. Change (dmax): 0.00%
 Limit (dmax): 4.00%
Relative Steady-state Voltage Change (dc): 0.03%
 Limit (dc): 3.30%
Maximum Interval exceeding 3.30% (dt): 0.00ms
 Limit (dt>Lim): 500ms

Flicker Emission - IEC 61000-3-3 , EN 61000-3-3 , (EN60555-3)

2015-5-19 17:23:57 harmonic.hsu

Urms = 229.9 V P = 2.601 W
 Irms = 0.032 A pf = 0.348

Range: 0.5 A
 V-nom: 230 V
 TestTime: 10 min (100%)

IPC-HFW4421EP
 MODE3

Test completed, Result: PASSED

HAR-1000 EMC-Partner

- Full Bar : Actual Values
- Empty Bar : Maximum Values
- Circles : Average Values
- Blue : Current , Green : Voltage , Red : Failed



Urms = 229.9V Freq = 50.000 Range: 0.5 A
Irms = 0.032A Ipk = 0.202A cf = 6.233
P = 2.601W S = 7.465VA pf = 0.348

Test - Time : 1 x 10min = 10min (100 %)

LIN (Line Impedance Network) : No LIN

Limits : Plt : 0.65 Pst : 1.00
dmax : 4.00 % dc : 3.30 %
dtLim: 3.30 % dt>Lim: 500ms

Test completed, Result: PASSED

Test engineer: 



7.4. Test Photographs





8. Electrostatic Discharge Immunity Test

8.1. Test Procedure

- a. In the case of air discharge testing the climatic conditions shall be within the following ranges:
 - ambient temperature: 15°C to 35°C;
 - relative humidity : 30% to 60%;
 - atmospheric pressure : 86 KPa (860 mbar) to 106 KPa (1060 mbar).
- b. Test programs and software shall be chosen so as to exercise all normal modes of operation of the EUT. The use of special exercising software is encouraged, but permitted only where it can be shown that the EUT is being comprehensively exercised.
- c. The test voltage shall be increased from the minimum to the selected test severity level, in order to determine any threshold of failure. The final severity level should not exceed the product specification value in order to avoid damage to the equipment.
- d. The test shall be performed with both air discharge and contact discharge. On reselected points at least 10 single discharges (in the most sensitive polarity) shall be applied on air discharge. On reselected points at least 25 single discharges (in the most sensitive polarity) shall be applied on contact discharge.
- e. For the time interval between successive single discharges an initial value of one second is recommended. Longer intervals may be necessary to determine whether a system failure has occurred.
- f. In the case of contact discharges, the tip of the discharge electrode shall touch the EUT before the discharge switch is operated.
- g. In the case of painted surface covering a conducting substrate, the following procedure shall be adopted :
 - If the coating is not declared to be an insulating coating by the equipment manufacturer, then the pointed tip of the generator shall penetrate the coating so as to make contact with the conducting substrate.
 - Coating declared as insulating by the manufacturer shall only be submitted to the air discharge.
 - The contact discharge test shall not be applied to such surfaces.
- h. In the case of air discharges, the round discharge tip of the discharge electrode shall be approached as fast as possible (without causing mechanical damage) to touch the EUT . After each discharge, the ESD generator (discharge electrode) shall be removed from the EUT. The generator is then retriggered for a new single discharge. This procedure shall be repeated until the discharges are completed. In the case of an air discharge test, the discharge switch, which is used for contact discharge, shall be closed.

8.2. Test Setup for Tests Performed in Laboratory

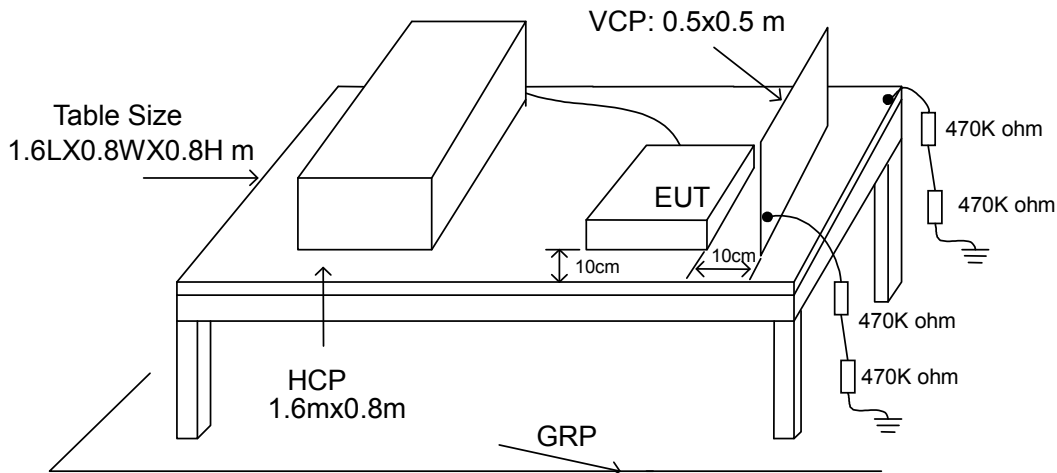

The test setup consists of the test generator, EUT and auxiliary instrumentation necessary to perform DIRECT and INDIRECT application of discharges to the EUT as applicable, in the follow manner :

- a. Contact Discharge to the conductive surfaces and to coupling plane;
- b. Air Discharge at insulating surfaces.

The preferred test method is that of type tests performed in laboratories and the only accepted method of demonstrating conformance with this standard. The EUT was arranged as closely as possible to arrangement in final installed conditions.

A ground reference plane was provided on the floor of the test site. It was a metallic sheet (copper or aluminum) of 0.25 mm, minimum thickness; other metallic may be used but they shall have at least 0.65 mm thickness. In the CerpPASS Technology Corp., we provided 1 mm thickness stainless steel ground reference plane. The minimum size of the ground reference plane is 2.5 m x 2.5 m, the exact size depending on the dimensions of the EUT. It was connected to the protective grounding system.

The EUT was arranged and connected according to its functional requirements. A distance of 1m minimum was provided between the EUT and the wall of the lab. and any other metallic structure. In cases where this length exceeds the length necessary to apply the discharges to the selected points, the excess length shall, where possible, be placed non-inductively off the ground reference plane and shall not come closer than 0.2m to other conductive parts in the test setup.

Where the EUT is installed on a metal table, the table was connected to the reference plane via a cable with a 470k ohm resistor located at each end, to prevent a build-up of charge. The test setup was consist a wooden table, 0.8m high, standing on the ground reference plane. A HCP, 1.6 m x 0.8 m, was placed on the table. The EUT and cables was isolated from the HCP by an insulating support 0.5 mm thick. The VCP size, 0.5 m x 0.5 m.



8.3. Test Severity Levels

Contact Discharge		Air Discharge	
Level	Test Voltage (KV) of Contact discharge	Level	Test Voltage (KV) of Air Discharge
1	±2	1	±2
2	±4	2	±4
3	±6	3	±8
4	±8	4	±15
X	Specified	X	Specified

Remark: "X" is an open level.

8.4. Measurement Equipment

Instrument/Ancillary	Manufacturer	Model No.	Serial No.	Calibration Date	Valid Date.
ESD Simulator	EM Test	dito	V0714102399	2015.03.29	2016.03.28
Tonometer	shanghaifengyun	DYM3	3251	2014.12.01	2015.11.30
Dehumidifier	ZEDO	ZD-220LB	CEP-TH-01	N/A	N/A
Humidifier	YADU	YZ-DS251C	CEP-TH-02	N/A	N/A
Temperature/ Humidity Meter	feiyang	N/A	102	2015.04.02	2016.04.01



8.5. Test Result and Data

Basic Standard : IEC 61000-4-2
 Product Standard : EN 50130-4: 2011
 Product Standard : EN 55024 : 2010
 Equipment : Network Bullet Camera
 Model No. : PI-SPW403L
 Final Test Result : PASS
 Temperature : 22 °C
 Relative Humidity : 46 %
 Atmospheric Pressure : 101 kPa
 Test Date : May 22, 2015

Test Mode 1

For EN 55024: 2010

Test Voltage: AC 230V/50Hz

Test Voltage: 230V/50Hz																
	Contact Discharge								Air Discharge							
	25 times / each								10 times / each							
Voltage	2 kV		4 kV		6 kV		8 kV		2 kV		4 kV		8 kV		10 kV	
Point\Polarity	+	-	+	-	+	-	+	-	+	-	+	-	+	-	+	-
HCP	A	A	A	A	---	---	---	---	---	---	---	---	---	---	---	---
VCP	A	A	A	A	---	---	---	---	---	---	---	---	---	---	---	---
1-21	A	A	A	A	---	---	---	---	---	---	---	---	---	---	---	---
22-27	---	---	---	---	---	---	---	---	A	A	A	A	A	A	---	---

For EN 50130-4: 2011

Test Voltage: 230V/50Hz																
	Contact Discharge								Air Discharge							
	25 times / each								10 times / each							
Voltage	2 kV		4 kV		6 kV		8 kV		2 kV		4 kV		8 kV		10 kV	
Point\Polarity	+	-	+	-	+	-	+	-	+	-	+	-	+	-	+	-
HCP	A	A	A	A	A	A	---	---	---	---	---	---	---	---	---	---
VCP	A	A	A	A	A	A	---	---	---	---	---	---	---	---	---	---
1-21	A	A	A	A	A	A	---	---	---	---	---	---	---	---	---	---
22-27	---	---	---	---	---	---	---	---	A	A	A	A	A	A	---	---



Test Voltage:195.5V/50Hz																
	Contact Discharge								Air Discharge							
	25 times / each								10 times / each							
Voltage	2 kV		4 kV		6 kV		8 kV		2 kV		4 kV		8 kV		10 kV	
Point\Polarity	+	-	+	-	+	-	+	-	+	-	+	-	+	-	+	-
HCP	A	A	A	A	A	A	---	---	---	---	---	---	---	---	---	---
VCP	A	A	A	A	A	A	---	---	---	---	---	---	---	---	---	---
1-21	A	A	A	A	A	A	---	---	---	---	---	---	---	---	---	---
22-27	---	---	---	---	---	---	---	---	A	A	A	A	A	A	---	---

Test Voltage:253V/50Hz																
	Contact Discharge								Air Discharge							
	25 times / each								10 times / each							
Voltage	2 kV		4 kV		6 kV		8 kV		2 kV		4 kV		8 kV		10 kV	
Point\Polarity	+	-	+	-	+	-	+	-	+	-	+	-	+	-	+	-
HCP	A	A	A	A	A	A	---	---	---	---	---	---	---	---	---	---
VCP	A	A	A	A	A	A	---	---	---	---	---	---	---	---	---	---
1-21	A	A	A	A	A	A	---	---	---	---	---	---	---	---	---	---
22-27	---	---	---	---	---	---	---	---	A	A	A	A	A	A	---	---

Test engineer: Seben



8.6. Test Photographs



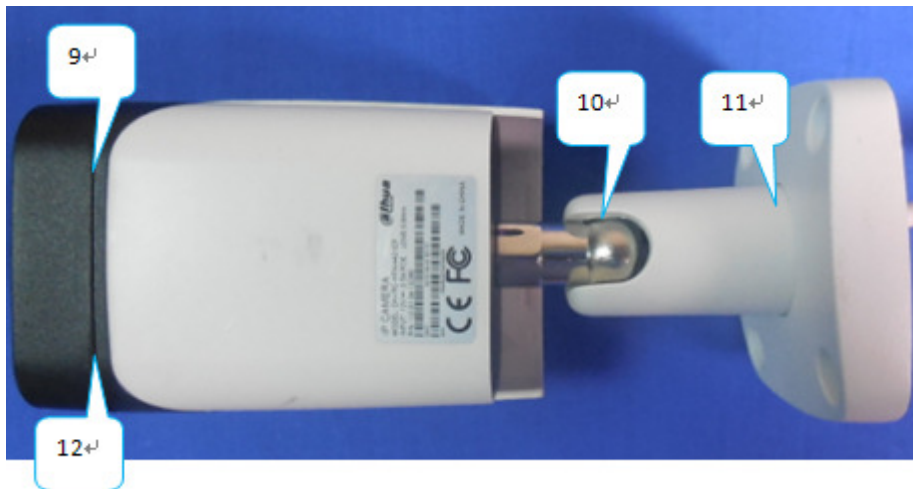
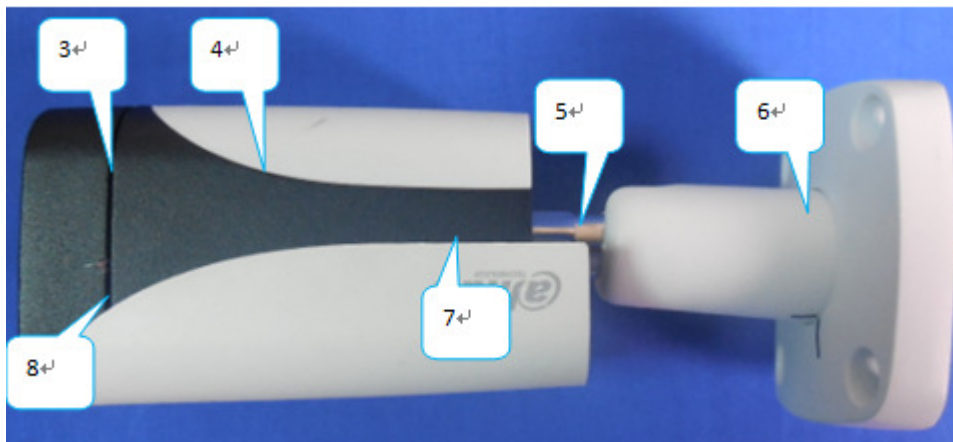
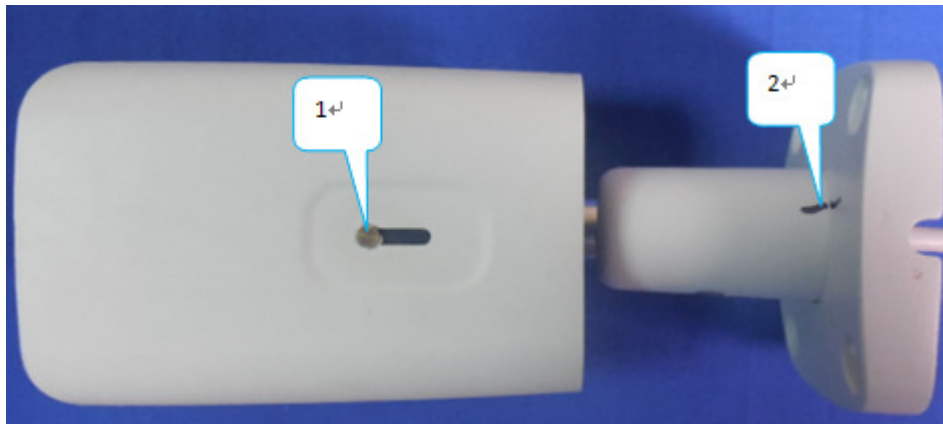

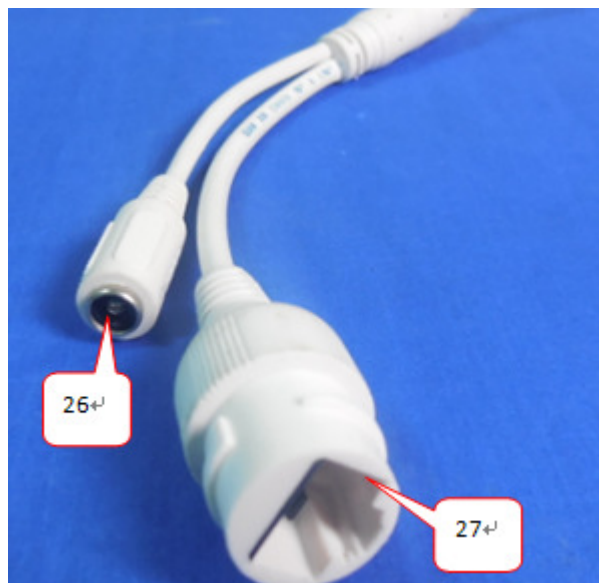
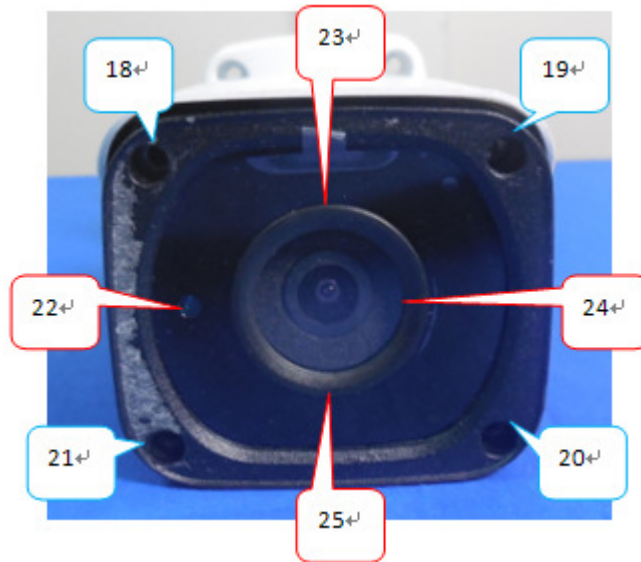
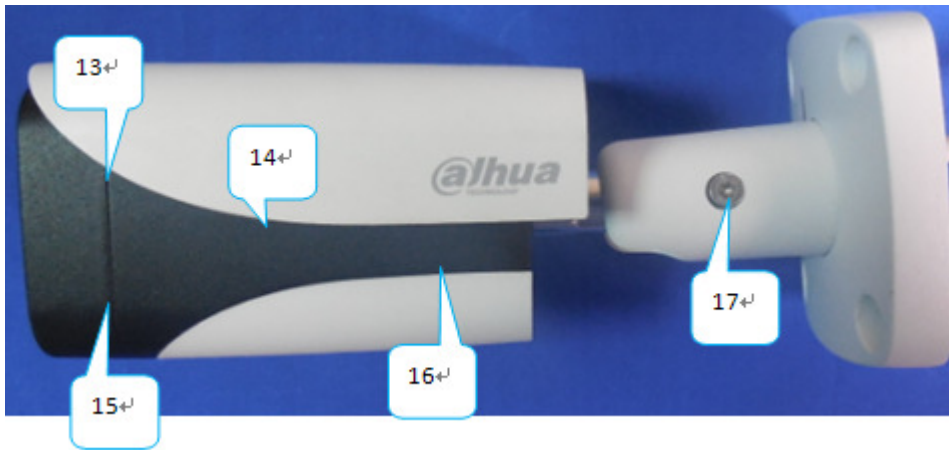



9. Radio Frequency electromagnetic field immunity test

9.1. Test Procedure

- a. The equipment to be tested is placed in the center of the enclosure on a wooden table. The equipment is then connected to power and signal leads according to pertinent installation instructions.
- b. The antenna which is enabling the complete frequency range of 80-1000 MHz is placed 3m away from the equipment. The required field strength is determined by placing the field strength meter(s) on top of or directly alongside the equipment under test and monitoring the field strength meter via a remote field strength indicator outside the enclosure while adjusting the continuous-wave to the applicable antennae.
- c. The test is normally performed with the antenna facing the most sensitive side of the EUT. The polarization of the field generated by the bucolical antenna necessitates testing each position twice, once with the antenna positioned vertically and again with the antenna positioned horizontally. The circular polarization of the field from the log-spiral antenna makes a change of position of the antenna unnecessary.
- d. At each of the above conditions, the frequency range is swept 80-1000 MHz, pausing to adjust the R.F. signal level or to switch oscillators and antenna. The rate of sweep is in the order of $1.5 \cdot 10^{-3}$ decades/s. The sensitive frequencies or frequencies of dominant interest may be discretely analyzed.

9.2. Test Severity Levels

Frequency Band : 80-1000 MHz	
Level	Test field strength (V/m)
1	1
2	3
3	10
X	Specified
Remark: "X" is an open class.	

9.3. TEST SETUP

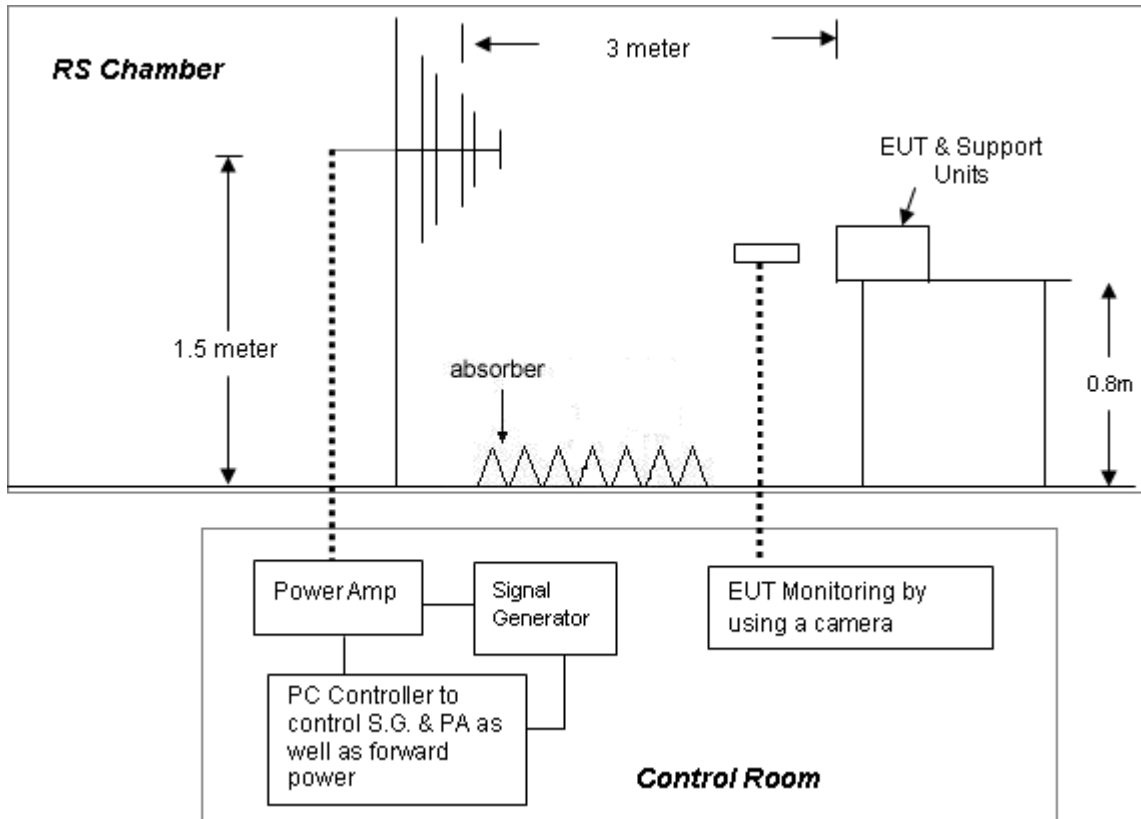

- For the actual test configuration, please refer to the related item – Photographs of the Test Configuration.

NOTE:

TABLETOP EQUIPMENT

The EUT installed in a representative system as described in section 7 of IEC 61000-4-3 was placed on a non-conductive table 0.8 meters in height. The system under test was connected to the power and signal wire according to relevant installation instructions.

FLOOR STANDING EQUIPMENT

The EUT installed in a representative system as described in section 7 of IEC 61000-4-3 was placed on a non-conductive wood support 0.1 meters in height. The system under test was connected to the power and signal wire according to relevant installation instructions.



9.4. Measurement Equipment

Instrument/Ancillary	Manufacturer	Model No.	Serial No.	Calibration Date	Valid Date.
Signal Generator	R&S	SML03	103287	2015.03.29	2016.03.28
Power Sensor	R&S	NR P-Z91	100383	2015.03.29	2016.03.28
Power Sensor	R&S	NRP-Z91	100384	2015.03.29	2016.03.28
Power Meter	R&S	NRP	101206	2015.03.29	2016.03.28
Power Amplifier	BONN	BLWA0830-16 0/100/40D	076659	2015.03.29	2016.03.28
Istropic Electric Field Probe	EST.LINDGRE N	HI-6105	137445	2014.09.01	2015.09.01
EMS Antenna	R&S	HL046E	100028	N/A	N/A
Temperature/ Humidity Meter	feiyang	N/A	101	2015.04.02	2016.04.01
EMC-32	Rohde&Schwa rz	Ver 6.10.0	N/A	N/A	N/A



9.5. Test Result and Data

Basic Standard : IEC 61000-4-3
 Product Standard : EN 50130-4: 2011
 Product Standard : EN 55024 : 2010
 Equipment : Network Bullet Camera
 Model No. : PI-SPW403L
 Final Test Result : PASS
 Temperature : 23°C
 Relative Humidity : 52 %
 Atmospheric Pressure : 101 kPa
 Test Date : May 23, 2015

Test Mode 1

For EN 55024: 2010

Test Voltage: AC 230V/50Hz

Modulation : AM 80% , 1KHz sine wave , Dwell time: 3.0 S				
Frequency Step Size : 1 % of preceding frequency value				
Frequency (MHz)	Antenna Polarization	face	Field strength (V/m)	Result
80~1000	Horizontal &Vertical	Front	3 V/m	A
80~1000	Horizontal &Vertical	Rear	3 V/m	A
80~1000	Horizontal &Vertical	Left	3 V/m	A
80~1000	Horizontal &Vertical	Right	3 V/m	A

For EN 50130-4: 2011

Test Voltage: AC 230V/50Hz

Modulation : AM 80% , 1KHz sine wave , Dwell time: 3.0S				
Frequency Step Size : 1 % of preceding frequency value				
Frequency (MHz)	Antenna Polarization	face	Field strength (V/m)	Result
80~2700	Horizontal &Vertical	Front	10 V/m	A
80~2700	Horizontal &Vertical	Rear	10 V/m	A
80~2700	Horizontal &Vertical	Left	10 V/m	A
80~2700	Horizontal &Vertical	Right	10 V/m	A



Test Voltage: AC 195.5V/50Hz

Modulation : AM 80% , 1KHz sine wave , Dwell time: 3.0 S				
Frequency Step Size : 1 % of preceding frequency value				
Frequency (MHz)	Antenna Polarization	face	Field strength (V/m)	Result
80~2700	Horizontal &Vertical	Front	10 V/m	A
80~2700	Horizontal &Vertical	Rear	10 V/m	A
80~2700	Horizontal &Vertical	Left	10 V/m	A
80~2700	Horizontal &Vertical	Right	10 V/m	A

Test Voltage: AC 253V/50Hz

Modulation : AM 80% , 1KHz sine wave , Dwell time: 3.0 S				
Frequency Step Size : 1 % of preceding frequency value				
Frequency (MHz)	Antenna Polarization	face	Field strength (V/m)	Result
80~2700	Horizontal &Vertical	Front	10 V/m	A
80~2700	Horizontal &Vertical	Rear	10 V/m	A
80~2700	Horizontal &Vertical	Left	10 V/m	A
80~2700	Horizontal &Vertical	Right	10 V/m	A

Test engineer: Seben



9.6. Test Photographs

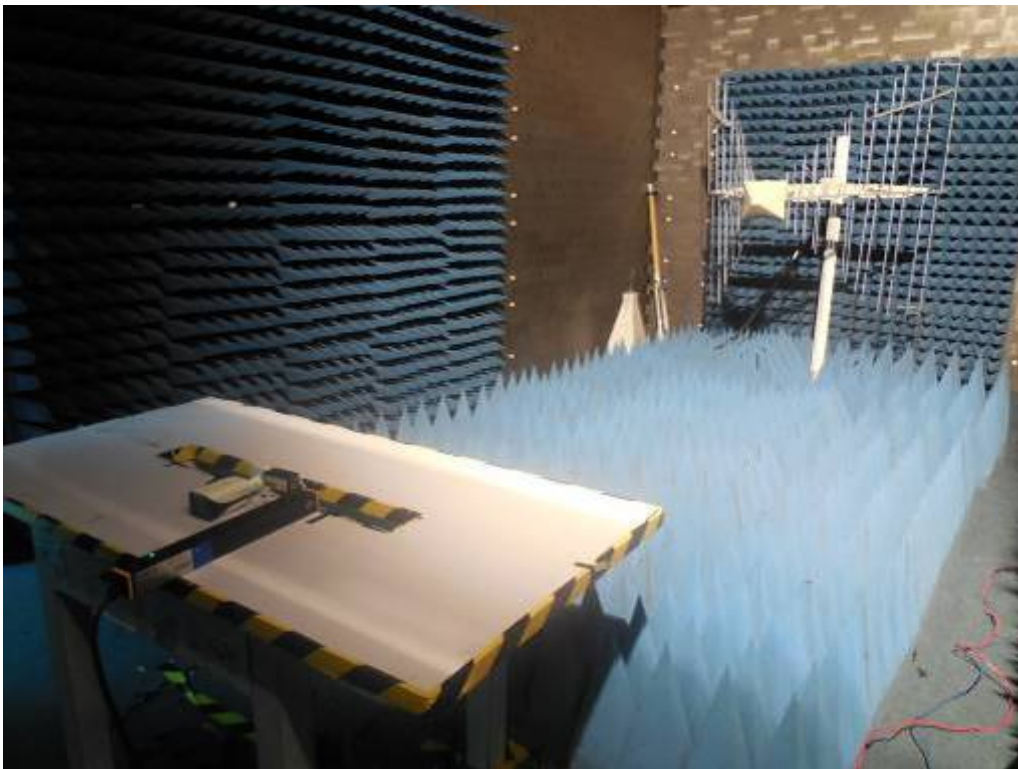
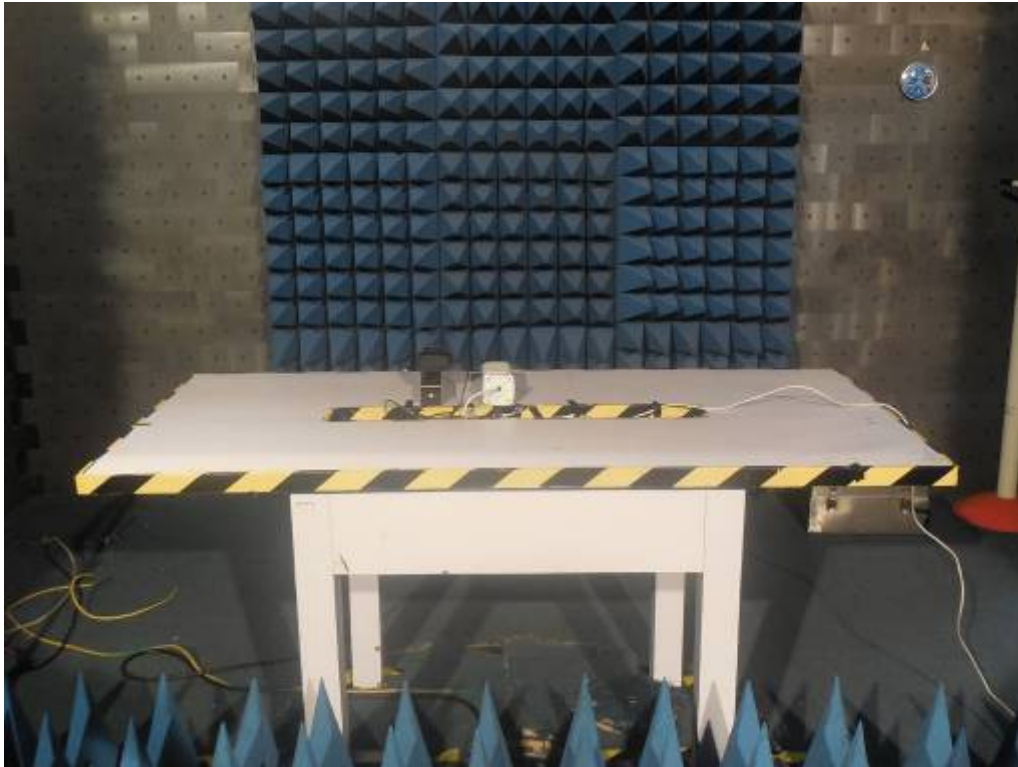



10. Electrical Fast Transient/ Burst Immunity Test

10.1. Test Procedure

- a. In order to minimize the effect of environmental parameters on test results, the climatic conditions when test is carrying out shall comply with the following requirements:
 - ambient temperature: 15°C to 35°C;
 - relative humidity : 45% to 75%;
 - Atmospheric pressure: 86 Kpa (860 mbar) to 106 Kpa (1060 mbar).
- b. In order to minimize the effect of environmental parameters on test results, the electromagnetic environment of the laboratory shall not influence the test results.
- c. The variety and diversity of equipment and systems to be tested make it difficult to establish general criteria for the evaluation of the effects of fast transients/bursts on equipment and systems.
- d. Test on Power Line:
 - The EFT/B-generator was located on the GRP.
For floor standing equipment 1,0 m
For table top equipment 0,5 m
 - The EFT/B-generator provides the ability to apply the test voltage in a non-symmetrical condition to the power supply input terminals of the EUT.
- e. Test on Communication Lines
 - The coupling clamp is composed of a clamp unit for housing the cable (length more than 3 m), and was placed on the GRP.
 - The coupling clamp provides the ability of coupling the fast transient/bursts to the cable under test.
- f. The test results may be classified on the basic of the operating conditions and the functional specification of the equipment under test, according to the following performance criteria :
 - Normal performance within the specification limits.
 - Temporary degradation or loss of function or performance which is self-recoverable.
 - Temporary degradation or loss of function or performance which requires operator intervention or system reset.
 - Degradation or loss of function which is not recoverable due to damage of equipment (components).

10.2. Test Severity Levels

The following test severity levels are recommended for the fast transient/burst test :

Open circuit output test voltage $\pm 10\%$		
Level	On Power Supply	On I/O signal, data and control line
1	0.5 KV	0.25 KV
2	1.0 KV	0.50 KV
3	2.0 KV	1.00 KV
4	4.0 KV	2.00 KV
X	Specified	Specified

Remark : “ X ” is an open level. The level is subject to negotiation between the user and manufacturer or is specified by the manufacturer.

10.3. TEST SETUP

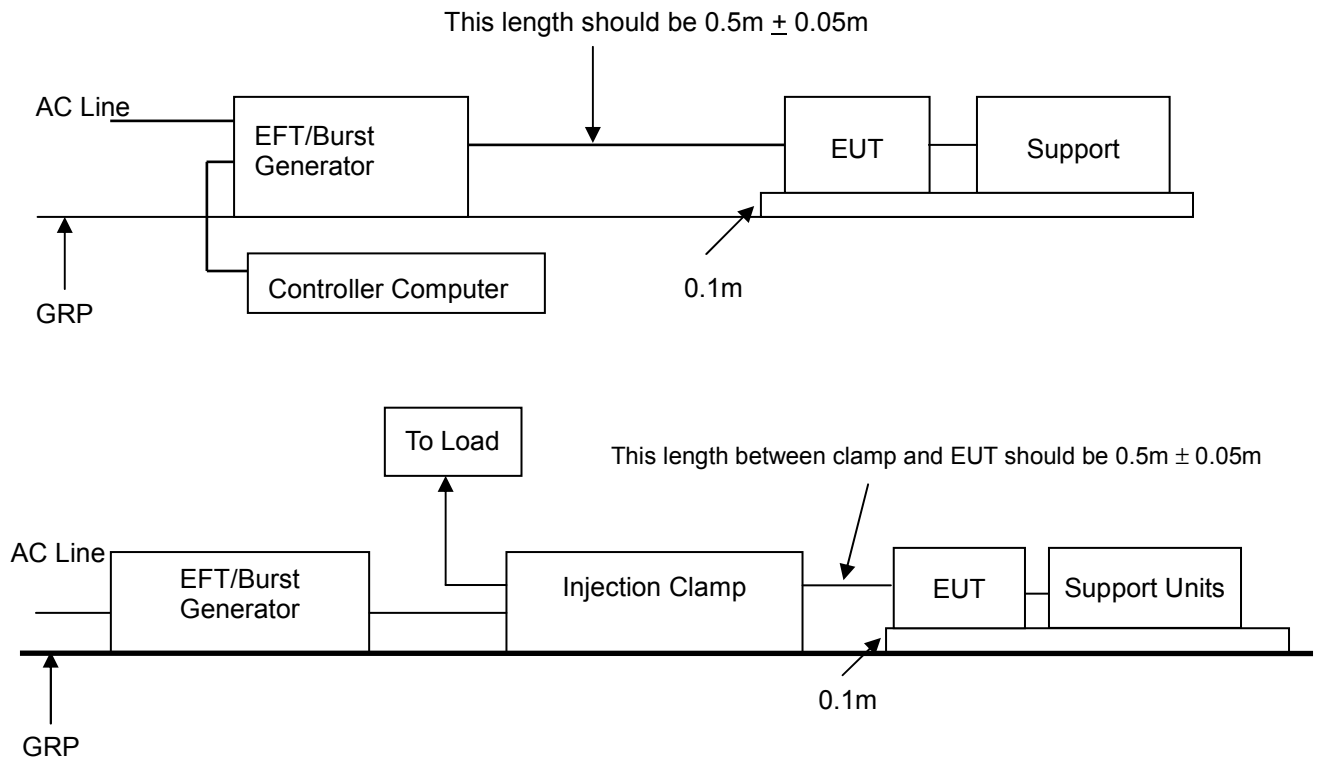

- For the actual test configuration, please refer to the related item – Photographs of the Test Configuration.

NOTE:

TABLETOP EQUIPMENT

The configuration consisted of a wooden table (0.1m high) standing on the Ground Reference Plane. The GRP consisted of a sheet of aluminum (at least 0.25mm thick and 2.5m square) connected to the protective grounding system. A minimum distance of 0.5m was provided between the EUT and the walls of the laboratory or any other metallic structure.

FLOOR STANDING EQUIPMENT

The EUT installed in a representative system as described in section 7 of IEC 61000-4-4 and its cables, were isolated from the Ground Reference Plane by an insulating support that is 0.1-meter thick. The GRP consisted of a sheet of aluminum (at least 0.25mm thick and 2.5m square) connected to the protective grounding system.



10.4. Measurement Equipment

Instrument/Ancillary	Manufacturer	Model No.	Serial No.	Calibration Date	Valid Date.
TRANSIENT	EMCPARTNER	TRA2000IN6	901	2015.03.29	2016.03.28
CDN	EMCPARTNER	CDN2000-06-32	121	2015.03.29	2016.03.28
Coupling clamp	EMCPARTNER	CN-EFT1000	547	2015.03.29	2016.03.28
Temperature/ Humidity Meter	Zhicheng	ZC1-11	CEP-TH-005	2015.04.02	2016.04.01



10.5. Test Result and Data

Basic Standard : IEC 61000-4-4
 Product Standard : EN 50130-4: 2011
 Product Standard : EN 55024 : 2010
 Equipment : Network Bullet Camera
 Model No. : PI-SPW403L
 Final Test Result : PASS
 Temperature : 24 °C
 Relative Humidity : 49 %
 Atmospheric Pressure : 100 kPa
 Test Date : May 24, 2015

Test Mode 1

For EN 55024: 2010

Pulse : 5/50 ns		Repetition Rate: 5 kHz			
Burst : 15m/300ms		Test time : 1 min/each condition			
Voltage/ Mode/ Polarity/ Result/ Phase		<u>0.5 kV</u>		<u>1.0 kV</u>	
		+	-	+	-
Power Line	L	---	---	A	A
	N	---	---	A	A
	L-N	---	---	A	A
Signal Line	RJ45	A	A	---	---

For EN 50130-4: 2011

Test Voltage: AC 230V/50Hz

Pulse : 5/50 ns		Repetition Rate: 5/100 kHz			
Burst : 15m/300ms		Test time : 1 min/each condition			
Voltage/ Mode/ Polarity/ Result/ Phase		<u>1 kV</u>		<u>2.0 kV</u>	
		+	-	+	-
Power Line	L	---	---	A	A
	N	---	---	A	A
	L-N	---	---	A	A
Signal Line	RJ45	A	A	---	---



Test Voltage: AC 195.5V/50Hz

Pulse : 5/50 ns		Repetition Rate: 5/100 kHz			
Burst : 15m/300ms		Test time : 1 min/each condition			
Voltage/ Mode/ Polarity/ Result/ Phase		1 kV		2.0 kV	
		+	-	+	-
Power Line	L	---	---	A	A
	N	---	---	A	A
	L-N	---	---	A	A
Signal Line	RJ45	A	A	---	---

Test Voltage: AC 253V/50Hz

Pulse : 5/50 ns		Repetition Rate: 5/100 kHz			
Burst : 15m/300ms		Test time : 1 min/each condition			
Voltage/ Mode/ Polarity/ Result/ Phase		1 kV		2.0 kV	
		+	-	+	-
Power Line	L	---	---	A	A
	N	---	---	A	A
	L-N	---	---	A	A
Signal Line	RJ45	A	A	---	---

Test engineer: Seben



10.6. Test Photographs

Main

Front

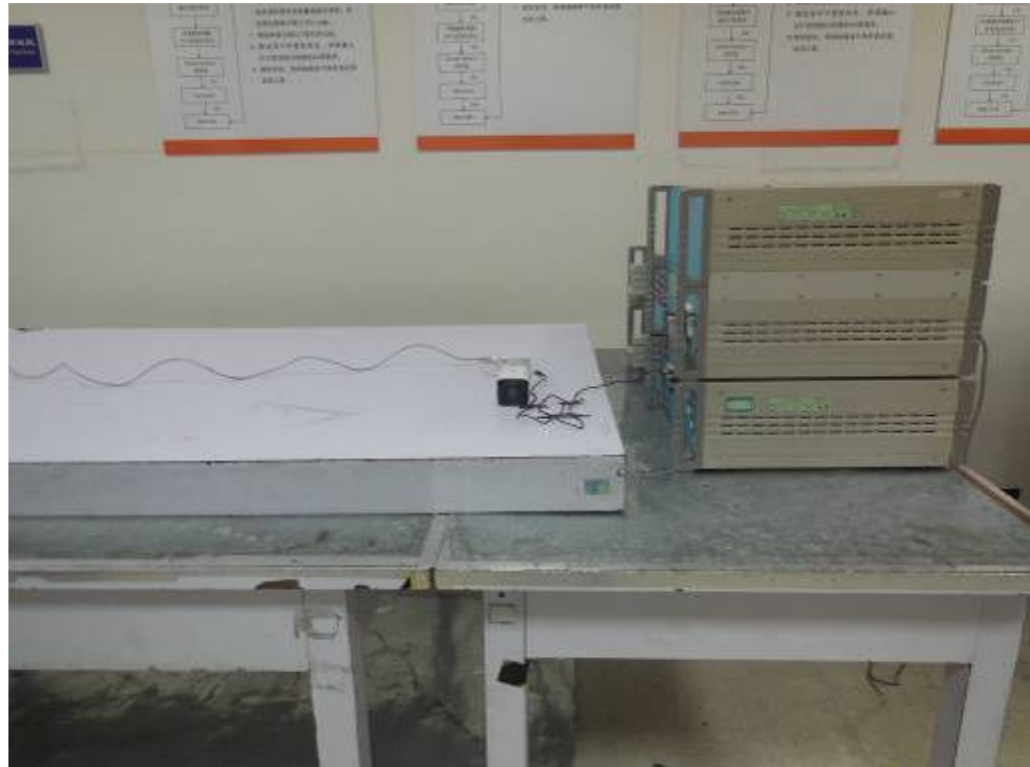

Rear

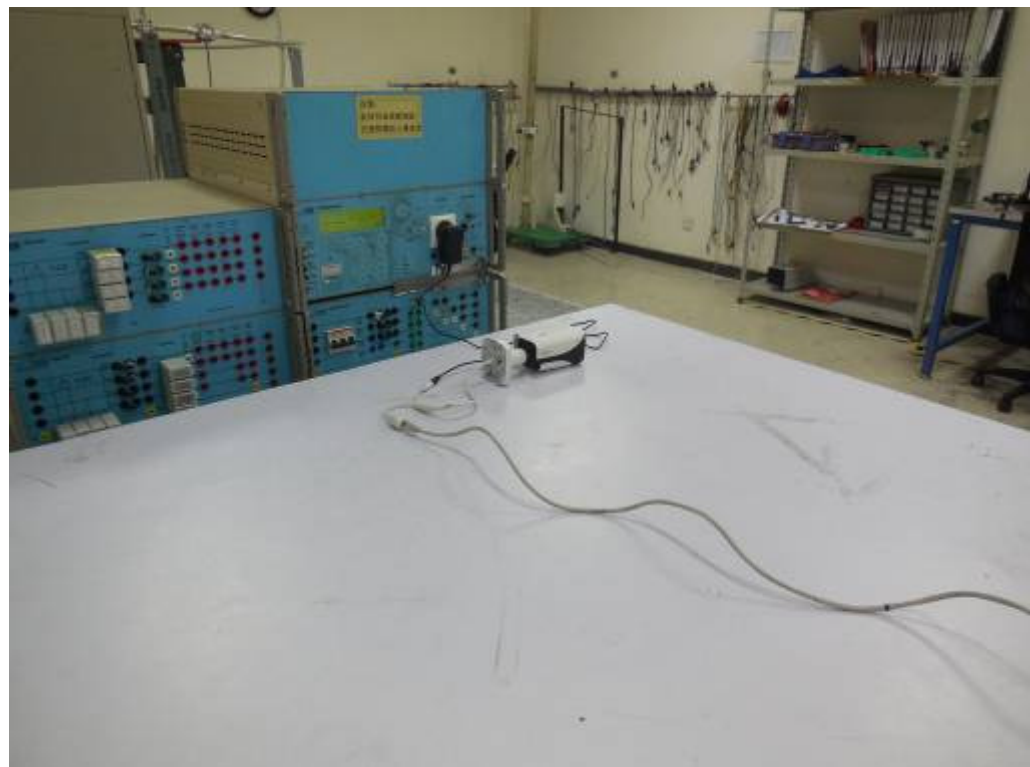



LAN

Front



Rear





11. Surge Immunity Test

11.1. Test Procedure

- a. Climatic conditions
The climatic conditions shall comply with the following requirements :
 - ambient temperature : 15 °C to 35 °C
 - relative humidity : 10 % to 75 %
 - atmospheric pressure : 86 kPa to 106 kPa (860 mbar to 1060 mbar)
- b. Electromagnetic conditions
the electromagnetic environment of the laboratory shall not influence the test results.
- c. The test shall be performed according the test plan that shall specify the test set-up with
 - generator and other equipment utilized;
 - test level (voltage/current);
 - generator source impedance;
 - internal or external generator trigger;
 - number of tests : at least five positive and five negative at the selected points;
 - repetition rate : maximum 1/min.
 - inputs and outputs to be tested;
 - representative operating conditions of the EUT;
 - sequence of application of the surge to the circuit;
 - phase angle in the case of AC. power supply;
 - actual installation conditions, for example :
 - AC : neutral earthed,
 - DC : (+) or (-) earthed to simulated the actual earthing conditions.
- d. If not otherwise specified the surges have to be applied synchronized to the voltage phase at the zero-crossing and the peak value of the AC. voltage wave (positive and negative).
- e. The surges have to be applied line to line and line(s) and earth. When testing line to earth, the test voltage has to be applied successively between each of the lines and earth, if there is no other specification.
- f. The test procedure shall also consider the non-linear current-voltage characteristics of the equipment under test. Therefore the test voltage has to be increased by steps up to the test level specified in the product standard or test plan.
- g. All lower levels including the selected test level shall be satisfied. For testing the secondary protection, the output voltage of the generator shall be increased up to the worst-case voltage breakdown level (let-through level) of the primary protection.
- h. If the actual operating signal sources are not available, that may be simulated. Under no circumstances may the test level exceed the product specification. The test shall be carried out according to a test plan.
- i. To find all critical points of the duty cycle of the equipment, a sufficient number of positive and negative test pulses shall be applied. For acceptance test previously unstressed equipment shall be used to the protection devices shall be replaced.

11.2. Test Severity Level

Level	Open-circuit test voltage, $\pm 10\%$, KV
1	0.5
2	1.0
3	2.0
4	4.0
X	Specified
NOTE: "X" is an open class. This level can be specified in the product specification.	



11.3. TEST SETUP

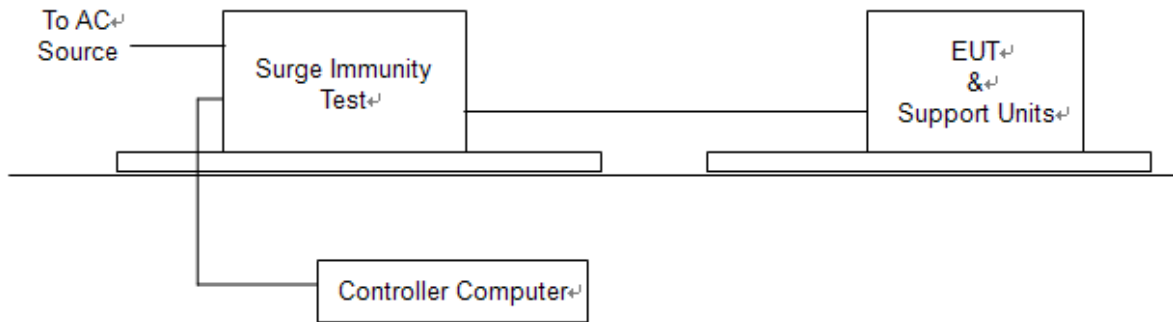

For the actual test configuration, please refer to the related item – Photographs of the Test Configuration.

11.4. Measurement Equipment

Instrument/Ancillary	Manufacturer	Model No.	Serial No.	Calibration Date	Valid Date.
TRANSIENT	EMCPARTNER	TRA2000IN6	901	2015.03.29	2016.03.28
CDN	EMCPARTNER	CDN-UTP8	021	2015.03.29	2016.03.28
CDN	EMCPARTNER	CDN2000-06-32	121	2015.03.29	2016.03.28
Temperature/ Humidity Meter	Zhicheng	ZC1-11	CEP-TH-005	2015.04.02	2016.04.01



11.5. Test Result and Data

Basic Standard : IEC 61000-4-5
 Product Standard : EN 50130-4: 2011
 Product Standard : EN 55024 : 2010
 Equipment : Network Bullet Camera
 Model No. : PI-SPW403L
 Final Test Result : PASS
 Temperature : 24 °C
 Relative Humidity : 49 %
 Atmospheric Pressure : 100 kPa
 Test Date : May 24, 2015

Test Mode 1
 For EN 55024: 2010

Power Port

Test Voltage:230V/50Hz						
Waveform : 1.2/50µs(8/20µs) Repetition rate : 60 sec Time : 20 time/each condition						
/Phase Voltage / Mode / Polarity / Result			0°	90°	180°	270°
<u>0.5/1.0 kV</u>	L-N	+	A	A	A	A
		-	A	A	A	A

Signal Port

Waveform :10/700µs Repetition rate : 60 sec Time : 5 time/each condition					
Voltage		<u>0.5 kV</u>		<u>1 kV</u>	
Mode / Polarity / Result		+	-	+	-
RJ45		A	A	A	A



For EN 50130-4: 2011

Power Port

Test Voltage:230V/50Hz						
Waveform : 1.2/50µs(8/20µs) Repetition rate : 60 sec Time : 20 time/each condition						
/Phase Voltage / Mode / Polarity / Result			0°	90°	180°	270°
<u>0.5/1.0 kV</u>	L-N	+	A	A	A	A
		-	A	A	A	A

Signal Port

Waveform : 1.2/50µs(8/20µs) Repetition rate : 60 sec Time : 5 time/each condition					
Voltage		<u>0.5 kV</u>		<u>1 kV</u>	
Mode / Polarity / Result		+	-	+	-
RJ45		A	A	A	A

Waveform : 10/700µs Repetition rate : 60 sec Time : 5 time/each condition					
Voltage		<u>0.5 kV</u>		<u>1 kV</u>	
Mode / Polarity / Result		+	-	+	-
RJ45		A	A	A	A

Power Port

Test Voltage:195.5V/50Hz						
Waveform : 1.2/50µs(8/20µs) Repetition rate : 60 sec Time : 20 time/each condition						
/Phase Voltage / Mode / Polarity / Result			0°	90°	180°	270°
<u>0.5/1.0 kV</u>	L-N	+	A	A	A	A
		-	A	A	A	A



Signal Port

Waveform : 1.2/50µs(8/20µs) Repetition rate : 60 sec Time : 5 time/each condition					
Voltage		<u>0.5 kV</u>		<u>1 kV</u>	
Mode / Polarity / Result		+	-	+	-
RJ45		A	A	A	A

Waveform : 10/700µs Repetition rate : 60 sec Time : 5 time/each condition					
Voltage		<u>0.5 kV</u>		<u>1 kV</u>	
Mode / Polarity / Result		+	-	+	-
RJ45		A	A	A	A

Power Port

Test Voltage:253V/50Hz						
Waveform : 1.2/50µs(8/20µs) Repetition rate : 60 sec Time : 20 time/each condition						
/Phase Voltage / Mode / Polarity / Result			0°	90°	180°	270°
<u>0.5/1.0 kV</u>	L-N	+	A	A	A	A
		-	A	A	A	A

Signal Port

Waveform : 1.2/50µs(8/20µs) Repetition rate : 60 sec Time : 5 time/each condition					
Voltage		<u>0.5 kV</u>		<u>1 Kv</u>	
Mode / Polarity / Result		+	-	+	-
RJ45		A	A	A	A

Waveform : 10/700µs Repetition rate : 60 sec Time : 5 time/each condition					
Voltage		<u>0.5 kV</u>		<u>1 kV</u>	
Mode / Polarity / Result		+	-	+	-
RJ45		A	A	A	A

Test engineer: 



11.6. Test Photographs





12. Conduction Disturbances induced by Radio-Frequency Fields

12.1. Test Procedure

- a. The EUT shall be operated within its intended climatic conditions. The temperature and relative humidity should be recorded.
- b. This test method test can be performed without using a sell shielded enclosure. This is because the disturbance levels applied and the geometry of the setups are not likely to radiated a high amount of energy, especially at the lower frequencies. If under certain circumstances the radiated energy is too high, a shielded enclosure has to be used.
- c. The test shall be performed with the test generator connected to each of the coupling and decoupling devices in turn while the other non-excited RF-input ports of the coupling devices are terminated by a 50 ohm load resistor.
- d. The frequency range is swept from 150 KHz to 80 MHz, using the signal levels established during the setting process, and with the disturbance signal 80% amplitude modulated with a 1KHz sign wave, pausing to adjust the RF-signal level or to switch coupling devices as necessary. The rate of sweep shall no exceed 1.5×10^{-3} decades/s. Where the frequency is swept incrementally, the step size shall no exceed 1% of the start and thereafter 1% of the preceding frequency value.
- e. The dwell time at each frequency shall not be less than the time necessary for the EUT to be exercised, and able to respond. Sensitive frequencies e.g. clock frequency (ies) and harmonics or frequencies of dominant interest shall be analyzed separately.
- f. An alternative test procedure may be adopted, wherein the frequency range is swept incrementally, with a step size not exceeding 4% of the start ad thereafter 4% of the preceding frequency value. The test level should be at least twice the value of the specified test level.
- g. In cases of dispute, the test procedure using a step size not exceeding 1% of the start and thereafter 1% of preceding frequency value shall take precedence.
- h. Attempts should be made to fully exercise the EUT during testing, and to fully interrogate all exercise modes selected for susceptibility.
- i. The use of special exercising programs is recommended.
- j. Testing shall be performed according to a Test Plan, which shall be included in the test report.
- k. It may be necessary to carry out some investigatory testing in order to establish some aspects of the test plan.

12.2. Test Severity Levels

Level	Voltage Level (e.m.f.)
1	1 V
2	3 V
3	10 V
x	Specified
NOTE - x is an open class. This level can be specified in the product specification.	

12.3.TEST SETUP

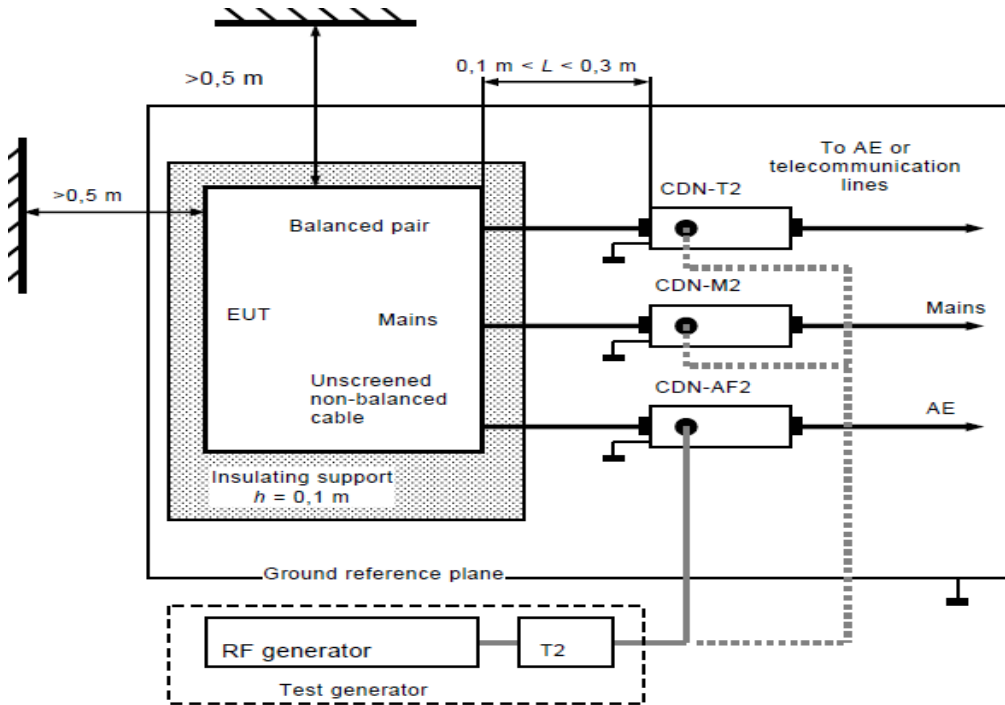

- Note:**
1. The EUT is setup 0.1m above Ground Reference Plane
 2. The CDNs and / or EM clamp used for real test depends on ports and cables configuration of EUT.
 3. For the actual test configuration, please refer to the related item – Photographs of the Test Configuration.

12.4.Measurement Equipment

Instrument/Ancillary	Manufacturer	Model No.	Serial No.	Calibration Date	Valid Date.
Conducted immunity test system	FRANKONIA	CIT-10/75	102D1294	2015.03.29	2016.03.28
EM Injection clamp	FCC	F-203I-23MM	536	2015.03.29	2016.03.28
CDN	FRANKONIA	CDN-T2	A3010029	2015.03.29	2016.03.28
CDN	FRANKONIA	CDN-T4	A3015017	2015.03.29	2016.03.28
CDN	FRANKONIA	CDN-T8	A3022010	2015.03.29	2016.03.28
CDN	FRANKONIA	CDN-M2	A3002037	2015.03.29	2016.03.28
CDN	FRANKONIA	CDN-M2+M3	A3011102	2015.03.29	2016.03.28
CDN	FCC	CDN-M5/32	A3013024	2015.03.29	2016.03.28
6 dB Attenuator	FRANKONIA	N/A	N/A	2015.03.29	2016.03.28
Temperature/ Humidity Meter	Zhicheng	ZC1-11	CEP-TH-005	2015.04.02	2016.04.01
EN61000-4-6	Hubert GmbH	Ver 2.21	N/A	N/A	N/A



12.5.Test Result and Data

Basic Standard : IEC 61000-4-6
 Product Standard : EN 50130-4: 2011
 Product Standard : EN 55024 : 2010
 Equipment : Network Bullet Camera
 Model No. : PI-SPW403L
 Final Test Result : PASS
 Temperature : 24 °C
 Relative Humidity : 49 %
 Atmospheric Pressure : 100 kPa
 Test Date : May 24, 2015

Test Mode 1

For EN 55024: 2010

Test Voltage: AC 230V/50Hz

Frequency : 0.15~80MHz, Modulation : AM 80%,1KHz sine wave, Dwell time: 3.0s Frequency Step Size : 1 % of preceding frequency value			
Frequency	Test mode	Voltage(V)	Result
0.15 ~ 80MHz	Power(M2)	3	A
0.15 ~ 80MHz	RJ45	3	A

For EN 50130-4: 2011

Test Voltage: AC 230V/50Hz

Frequency : 0.15~100MHz, Modulation : AM 80%,1KHz sine wave, Dwell time: 3.0s Frequency Step Size : 1 % of preceding frequency value			
Frequency	Test mode	Voltage(V)	Result
0.15 ~ 100MHz	Power(M2)	10	A
0.15 ~ 100MHz	RJ45	10	A



Test Voltage: AC 195.5V/50Hz			
Frequency : 0.15~100MHz, Modulation : AM 80%,1KHz sine wave, Dwell time: 3.0s			
Frequency Step Size : 1 % of preceding frequency value			
Frequency	Test mode	Voltage(V)	Result
0.15 ~ 100MHz	Power(M2)	10	A
0.15 ~ 100MHz	RJ45	10	A

Test Voltage: AC 253V/50Hz

Frequency : 0.15~100MHz, Modulation : AM 80%,1KHz sine wave, Dwell time: 3.0s			
Frequency Step Size : 1 % of preceding frequency value			
Frequency	Test mode	Voltage(V)	Result
0.15 ~ 100MHz	Power(M2)	10	A
0.15 ~ 100MHz	RJ45	10	A

Test engineer: Seben



12.6. Test Photographs

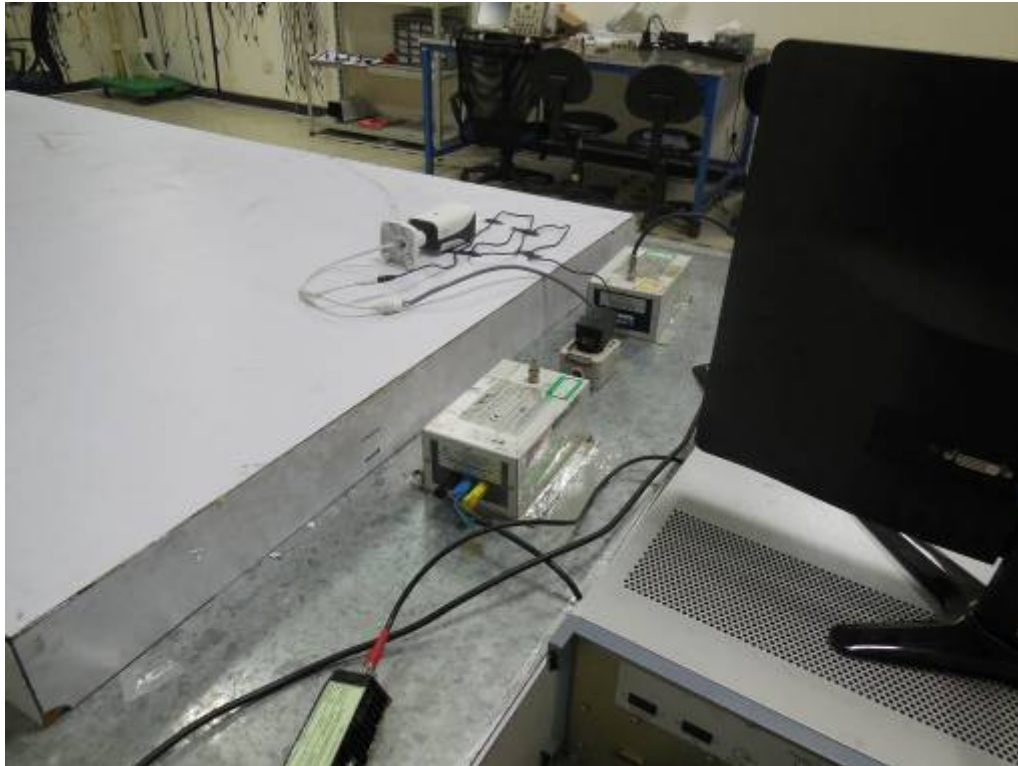

13. Power Frequency Magnetic Field Immunity Test

13.1. Test Setup

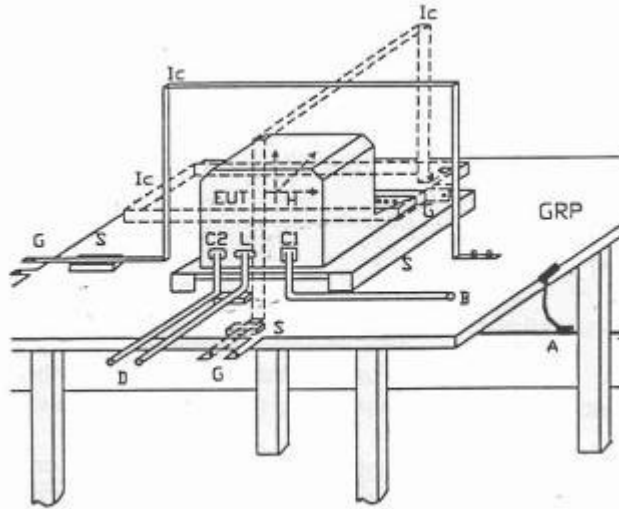

- GPR : Ground plane
- A : Safety earth
- S : Insulating support
- EUT : Equipment under test
- Lc : Induction coil
- E : Earth terminal
- C1 : Power supply circuit
- C2 : Signal circuit
- L : Communication line
- B : To power supply source
- D : To signal source, simulator
- G : To the test generator

13.2. Test Severity Levels

Level	Magnetic field strength (A/m)
1	1
2	3
3	10
4	30
5	100
X ¹⁾	special

NOTE 1 "X" is an open level. This level can be given in the product specification.

13.3. Measurement Equipment

Instrument/Ancillary	Manufacturer	Model No.	Serial No.	Calibration Date	Valid Date.
TRANSIENT	EMCPARTNER	TRA2000IN6	901	2015.03.29	2016.03.28
H-Filed-Loop	EMCPARTNER	MF1000-1	144	2015.03.29	2016.03.28
Temperature/ Humidity Meter	Zhicheng	ZC1-11	CEP-TH-005	2015.04.02	2016.04.01



13.4. Test Result and Data

Basic Standard : IEC 61000-4-8
 Product Standard : EN 55024 : 2010
 Equipment : Network Bullet Camera
 Model No. : PI-SPW403L
 Final Test Result : PASS
 Temperature : 24°C
 Relative Humidity : 49 %
 Atmospheric Pressure : 100 kPa
 Test Date : May 24, 2015

Test Mode 1

Power Frequency Magnetic Field : <u>50</u> Hz, <u>1</u> A/m		
Coil Orientation	Testing duration	Results
X-axis	1.0 Min	A
Y-axis	1.0 Min	A
Z-axis	1.0 Min	A
Power Frequency Magnetic Field : <u>60</u> Hz, <u>1</u> A/m		
Coil Orientation	Testing duration	Results
X-axis	1.0 Min	A
Y-axis	1.0 Min	A
Z-axis	1.0 Min	A

Test engineer: Seben



13.5. Test Photographs

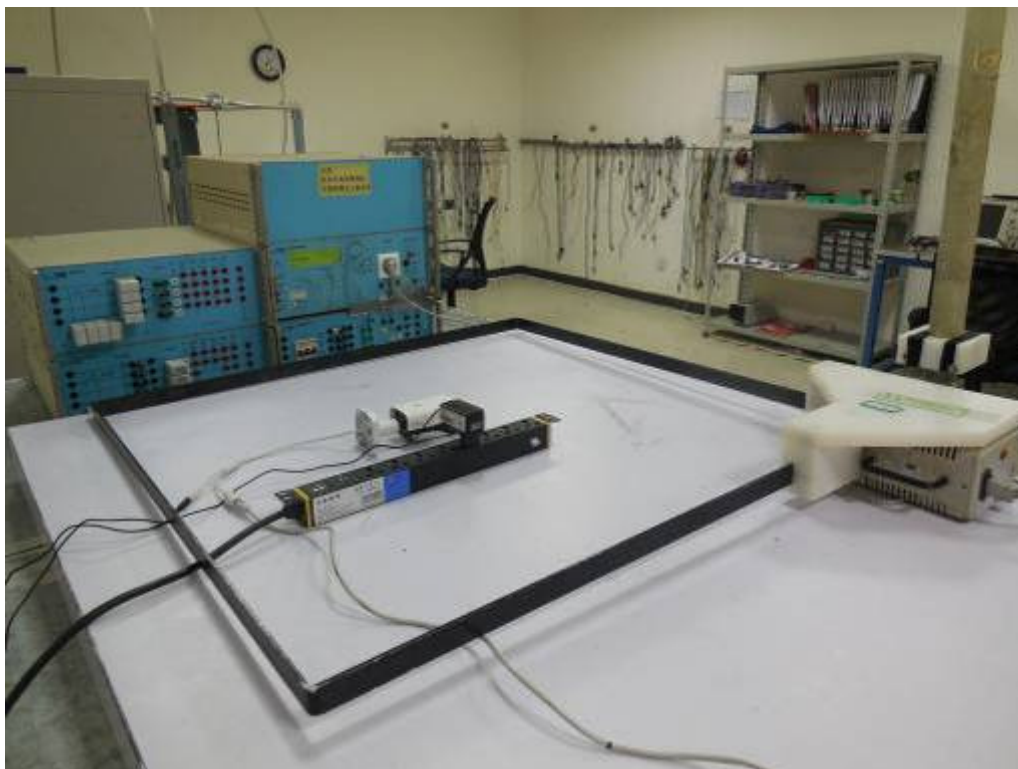

14. Voltage Dips and Voltage Interruptions Immunity Test Setup

14.1. Test Conditions

1. Source voltage and frequency : AC 100/230/240V / 50Hz, Single phase.
2. Test of interval : 10 sec.
3. Level and duration : Sequence of 3 dips/interrupts.
4. Voltage rise (and fall) time : 1 ~ 5 μ s.
5. Test severity :

Voltage dips and Interrupt reduction (%)	Test Duration (period)
>95%	250
30%	25
>95%	0.5

14.2. TEST SETUP

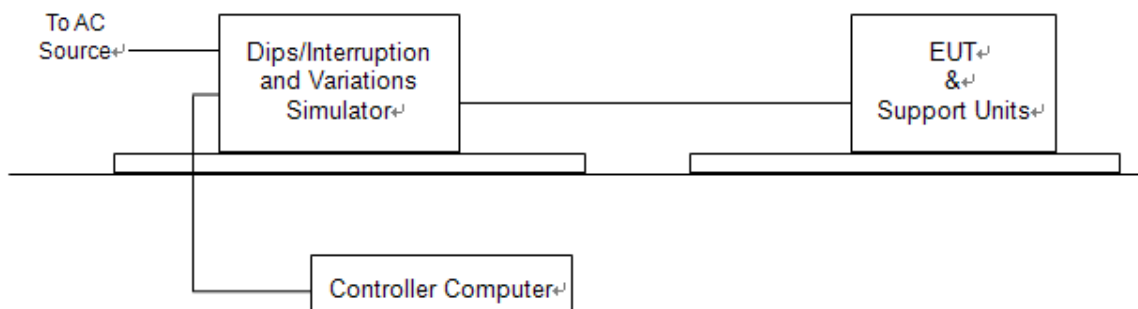

For the actual test configuration, please refer to the related item – Photographs of the Test Configuration.

14.3. Measurement Equipment

Instrument/Ancillary	Manufacturer	Model No.	Serial No.	Calibration Date	Valid Date.
TRANSIENT	EMCPARTNER	TRA2000IN6	901	2015.03.29	2016.03.28
Temperature/ Humidity Meter	Zhicheng	ZC1-11	CEP-TH-005	2015.04.02	2016.04.01



14.4. Test Result and Data

This project does not need to test.



15. EUT Photographs

1) EUT Photo



2) EUT Photo





3) EUT Photo



4) EUT Photo

