



ENERGY SAVINGS

TMEiC
We drive industry

METALS INDUSTRY

The steel industry is energy intensive with many opportunities to apply advanced controls to save energy. Some of the possible energy saving applications in a steel mill and the potential annual savings are illustrated here.

Energy saving systems typically use Variable Frequency Drives (VFD), mill feedback data, and expert mill operation knowledge to precisely control and reduce the energy flow through the equipment.

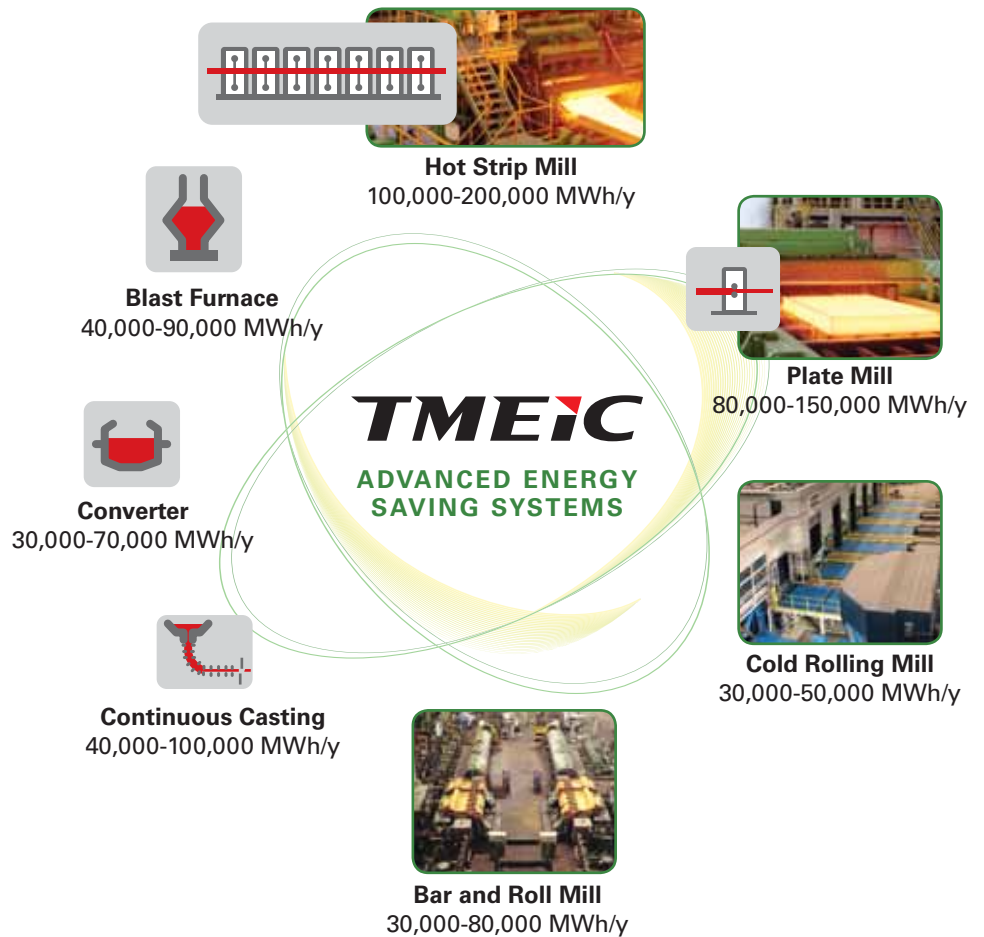

SAVINGS ACHIEVED

Some of the actual savings achieved by TMEiC on hot strip mills in Japan are shown here.

Main Motor Cooling Fan

Energy savings of 7,761 MWh/y through speed control of the cooling fan based on the load on the motor, winding temperature, and air temperature.

Fume Exhaust Fan

Energy savings of 3,973 MWh/y through fan speed control based on the exhaust air flow.

Auxiliary Motor Cooling

Energy savings of 2,176 MWh/y through speed control of the cooling fan based on the load on the motor, winding temperature, and air temperature.

Scale Pit Pump

Energy savings of 1,319 MWh/y through pump speed control based on the position of the slab relative to the descaler.

Cooling Water Pump

Energy savings of 5,017 MWh/y through pump speed control based on the tank level and calculated flow of cooling water to the run-out table.

Motor Cooling Fan Control

The large main motors on rolling mills are air-cooled and have an overhead heat exchanger supplied with cooling water. Generally, the cooling fan runs continuously at a constant speed using large amounts of energy, even when the motor is lightly loaded and does not need much cooling. This energy waste can be avoided.

To reduce the amount of wasted energy, a variable frequency drive (VFD) can be used to power the cooling fan motor. With the VFD, the fan speed can be reduced when motor loading is low and cooling is not required, and increased when the load is high, thereby considerably reducing fan energy consumption.

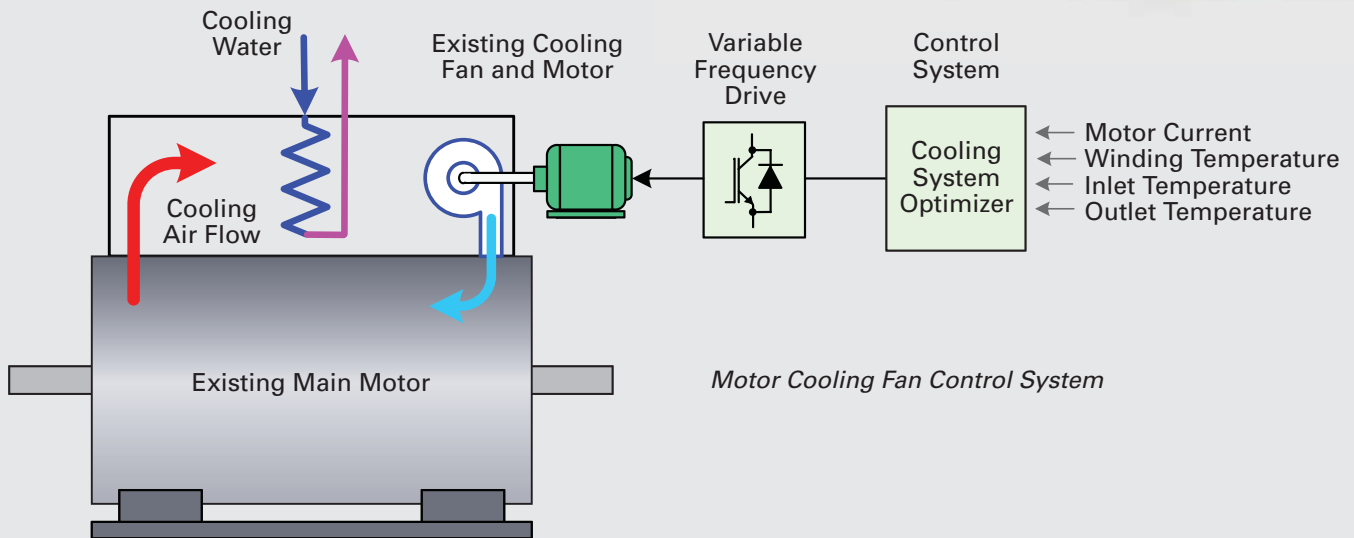

Motor Cooling Fan Control System

In the diagram above, the cooling system optimizer determines the speed of the motor cooling fan to obtain the required main motor cooling air flow. To do this the optimizer estimates the temperature rise of the main motor based on the real-time current, winding temperature, inlet temperature, and outlet temperature, and then adjusts the speed of the fan motor to produce the desired cooling flow.

Actual system tests were run on six main motors driving six finishing mills and five motors on three roughing mills. Results show that energy savings of 7,760 MWh/y can be achieved with this control method. Using ten cents per kWh electric cost, this is \$776,000 saved per year.

Similar tests on 14 smaller auxiliary mill motors showed that 2,170 MWh/y can be saved, representing \$217,000 per year.

METALS INDUSTRY

Cooling Water Flow Control on a Hot Strip Mill

On a hot strip mill, several run-out table pumps feed cooling water to the header tank, which supplies the laminar flow cooling tubes. Constant water level in the header tank produces a constant pressure at the flow control valves in the laminar flow lines and allows good flow control. If too much flow enters the header tank, the surplus water overflows into the scale water pit and wastes pumping energy.

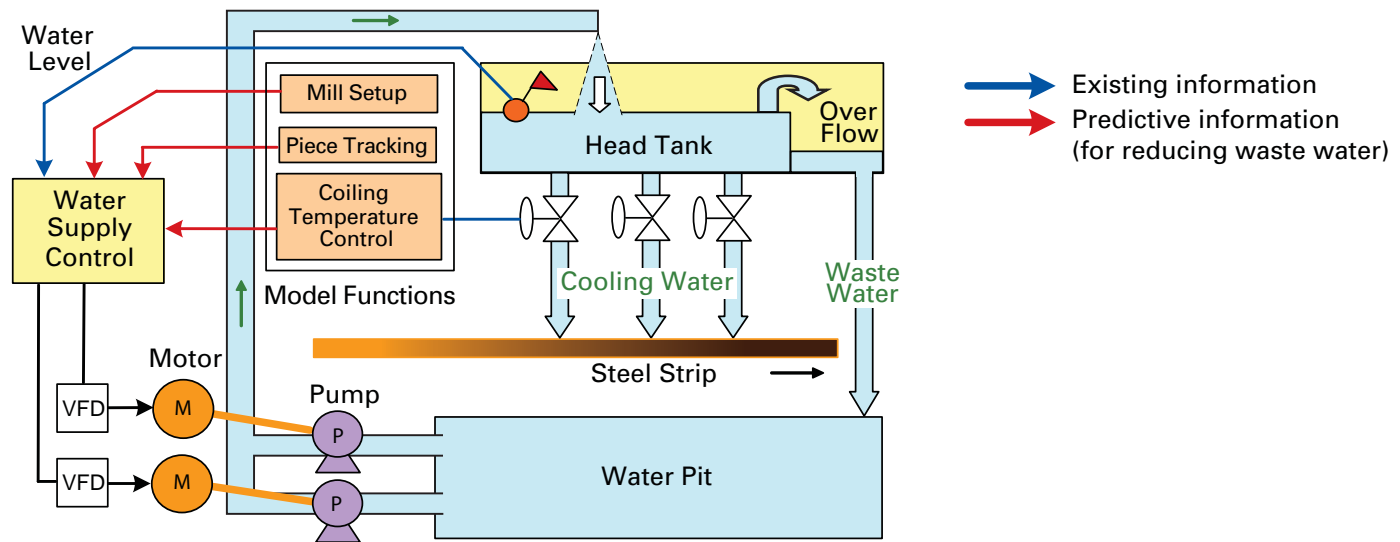

In order to improve this situation, a water supply control system has been developed, which uses existing control information and predictive information from the strip mill models. This control sets the speed of VFD's connected to the pump motors, and operates as follows:

- The Coiling Temperature Control (CTC) computer calculates the required flow of the cooling water in advance.
- The water supply controller receives the required cooling water flow data from the CTC computer, and the mill setup and piece tracking models.

- The water supply controller predicts the water volume using this information and determines the speed of the run-out table feed pumps.
- During a roll change, the run-out table feed pumps are stopped or slowed.

Using this system, pump energy savings of 5,010 MWh/y were realized on a steel mill coiling temperature control. With an electric cost of 10 cents per kWh, this represents a saving of \$501,000 per year.

Descaler Pump Energy Savings

In hot strip rolling mills, high pressure water jets are used to remove scale from the steel bars just before they enter the rolling mill. The descaler pump runs at a constant speed, and the high pressure water is bypassed to the water pit when no bar is present. Running the pump at a constant speed wastes energy and water and heavy maintenance is required on the motor, bypass valves, and the pump. If the roughing mill is reversing, there are descaler nozzles on either side, using even more energy.

An energy saving solution is to place a VFD on the pump to automatically reduce the water flow when the bar has left the descale area, thus reducing the load on the motor, the energy consumption, and water usage.

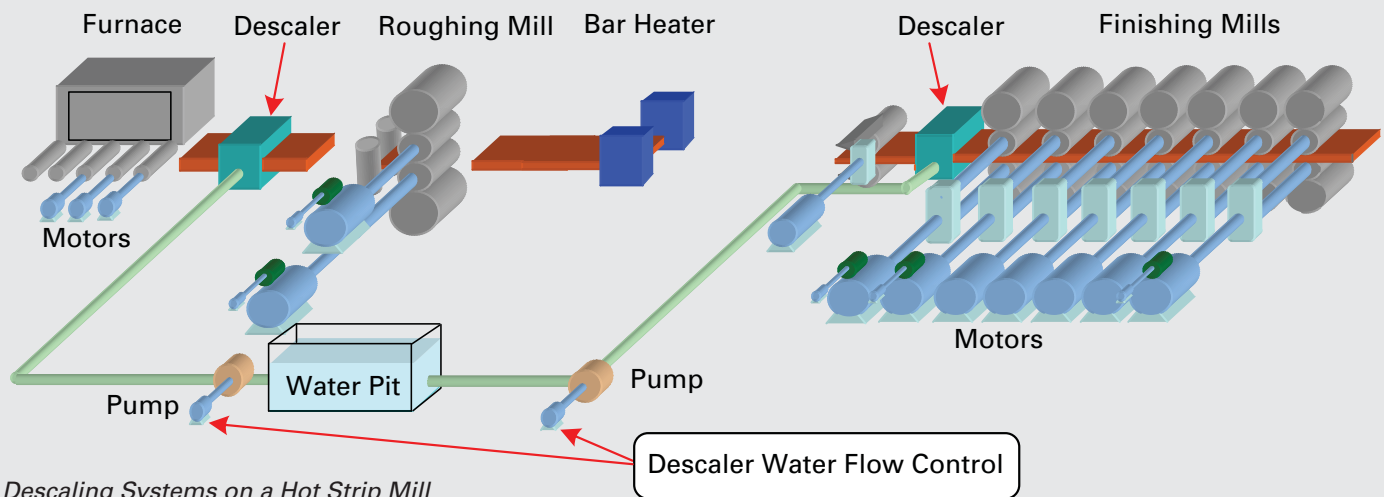

Descaling Systems on a Hot Strip Mill

In the above illustration there is a descaler before the roughing mill and a descaler before the finishing mill. The control system allows the bypass valve to be activated at lower pump speed and pressure. During mill delays the pump speed can be reduced, and during a roll change the pump can be stopped. Because pump power is proportional to speed cubed, when pump speed is reduced to 70%, the power drops to 35%, generating large energy savings.

In addition to energy savings, other advantages of the descaler control system using variable speed pump drives are:

- When the pump speed is reduced to 70%, the water pressure is reduced to 49%. At the lower pressure the pump and valve life is dramatically increased.

- Reducing the flow when descale is not in use economizes up to 40% of the water used. Clean water that will not clog up the descale nozzles is a valuable commodity in hot strip mills.
- VFD's avoid motor overloads during on-line starting and avert the resulting large voltage fluctuations, which can affect other sensitive equipment in the steel mill.

Control system tests in a steel mill show that annual electrical savings of 1,320 MWh/y can be achieved. If electric power cost is 10 cents per kWh, this represents electric power savings of \$132,000 per year.

WASTE HEAT RECOVERY SYSTEM



TMEIC's Waste Heat Recovery (WHR) system is an Organic Rankine Cycle (ORC)-based electrical generator powered by hot exhaust gas from a large industrial combustion process. The installation generates power from the waste heat, saving money, and may qualify for government monetary awards for clean energy.

Applications

The WHR system recovers heat energy lost through the exhaust stack from industrial combustion installations such as:

- Steel reheat furnaces
- Cement kilns
- Gas turbine and diesel generators
- Glass furnaces

The diagram to the right shows how furnace waste heat is captured and converted to electric power in a turbine generator. There are two closed loops, a hot liquid loop transferring heat, and an organic loop feeding the turbine (expander).

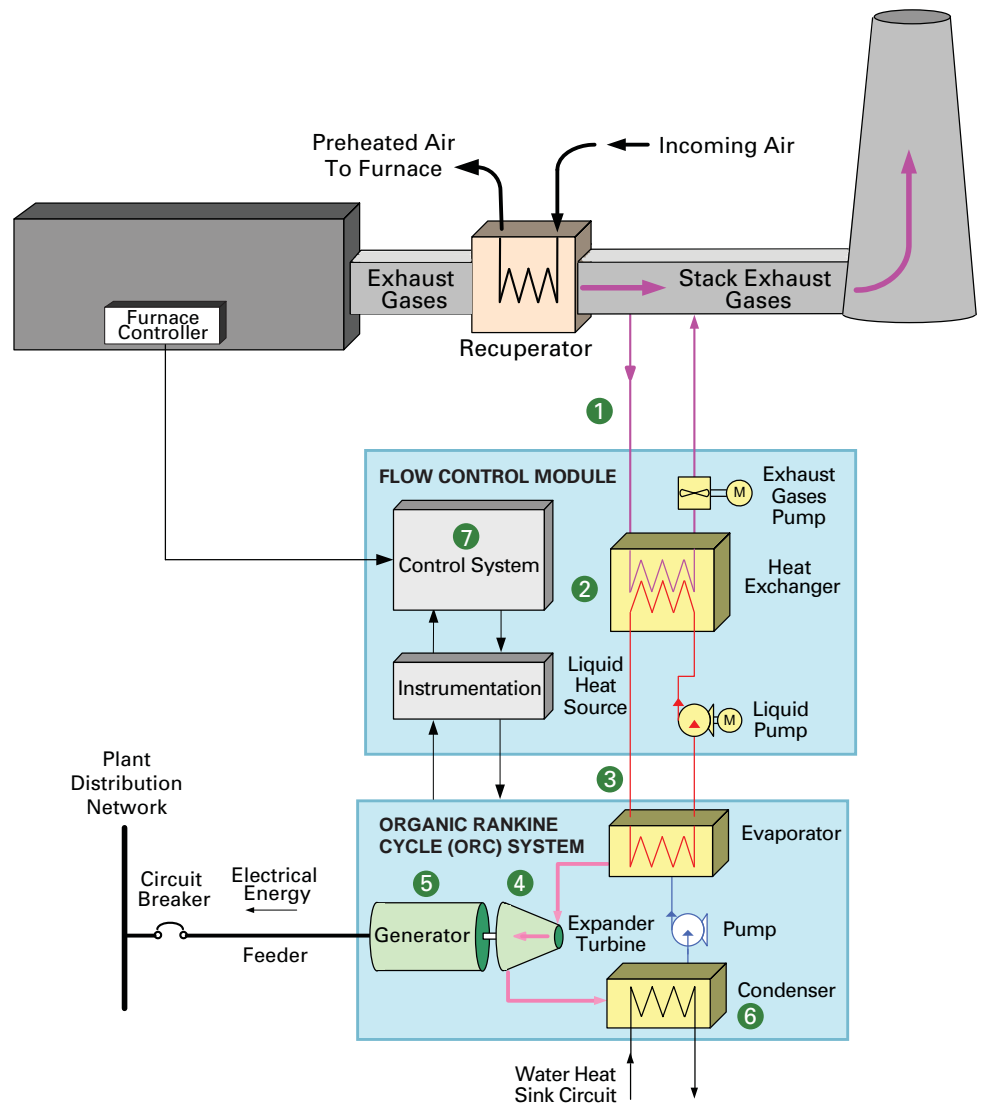

Waste Heat Recovery Energy Solution

System Operation

The process to capture the waste heat and generate electrical power are illustrated in the system diagram on page 6. Briefly, the steps are:

- 1 Hot exhaust gases are passed through the heat exchanger.
- 2 In the exchanger, heat is transferred from the hot exhaust gases to a liquid such as pressurized water/ glycol or thermal oil.
- 3 This hot liquid is pumped to the heat recovery evaporator in the Organic Rankine Cycle (ORC) system.
- 4 The refrigerant is boiled in the ORC evaporator and fed to an expander turbine, which drives the electrical generator.
- 5 The turbine generator generates electrical power, which is fed to the plant distribution network.
- 6 The exhaust refrigerant is condensed, using plant water as a heat sink and pumped back to the evaporator to repeat the cycle.
- 7 The master controller monitors system variables such as flow, pressure, temperature, and electrical power and controls the variable speed pumps for optimum thermal performance.



Steel Slab Exiting Furnace

POWER LEVELS AND SAVINGS

Waste Heat Recovery systems come in a wide range of sizes and power levels starting from 250 kW to several megawatts. For example, a typical steel reheat furnace with 320 metric tons per hour capacity would provide up to 2.25 MW (or 18,000,000 kWh per year) recoverable energy. The energy savings, at \$0.10 per kWh electric cost, amount to \$1,800,000 per year.

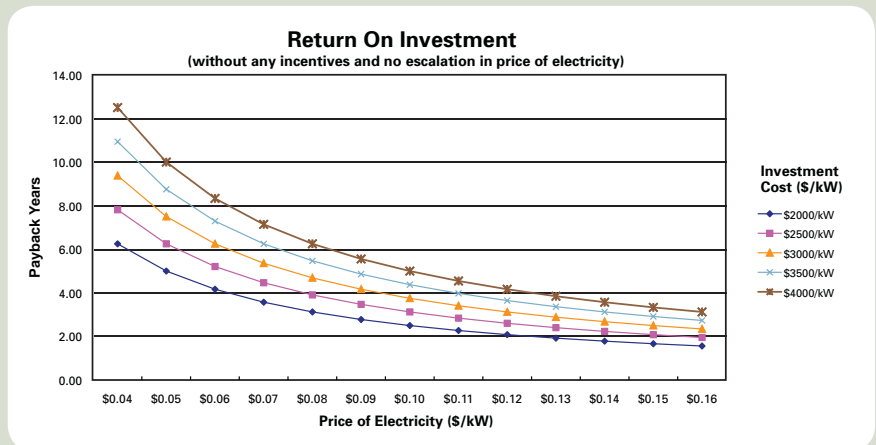

WOUND ROTOR INDUCTION MOTOR

Large Wound Rotor Induction Motors (WRIM) have been used in some industries for decades. In the cement and mining industries, high horsepower WRIM's operate on large grinding mills, where controlled starting characteristics and adjustable speed capability are advantages. These motors are also used on large pumps in the water and waste industry for the same reasons.

The motor has a 3-phase wound stator that is usually connected directly to the power system. The rotor has a 3-phase winding with the three terminals connected to separate slip rings.

The slip rings are normally connected to a liquid rheostat or resistor bank. The rheostat is used for starting and can be disconnected once the motor is up to speed. By changing rotor resistance with the rheostat, the motor speed can be changed.



Wound Rotor Induction Motor Driving a Grinding Mill

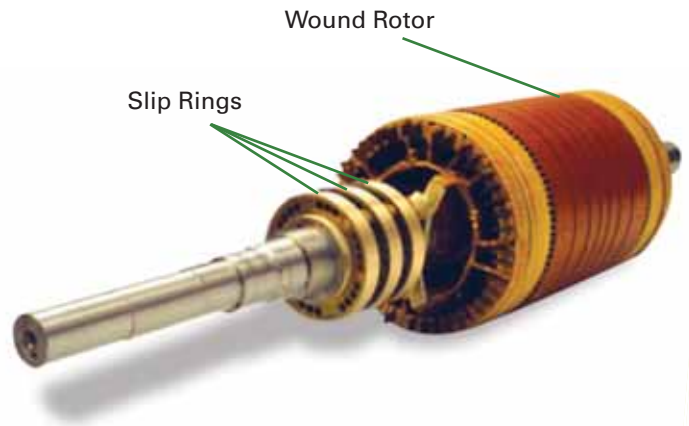

In the past, the power dissipated in the rheostat was lost as heat; however, using a variable frequency drive connected in place of the rheostat, the slip power can be recovered and returned to the utility supply, thus saving energy. By using the drive to increase the power taken off the rotor, the motor speed can be reduced. As a bonus, by putting power into the rotor through the drive, the motor can be run above synchronous speed, as long as the speed is within the motor design limits.

The slip power recovery system uses a state-of-the-art low voltage Pulse Width Modulated drive. This new implementation builds on the standard line of TMEIC low voltage induction motor drives used in the process industries such as metal processing and paper making. The hardware is very reliable and familiar and is appropriate for new or existing motors. The slip power is low voltage and only a small portion of the total motor power, so the drive required is low capacity and lower cost than a full size medium voltage drive.

Calculations for a 5,000 hp WRIM running at 90% full speed show that the recovered energy is 360 kW, worth over \$300,000 per year. Retrofit of an existing WRIM is straight forward, and the rheostat is left in place for starting.

FAN FLOW CONTROL

Large energy savings can be realized by changing the flow control on air handling machines such as large fans used on boilers and cement kilns. Many older fans have louvers, dampers, or inlet guide vanes for controlling the air flow. Inlet vanes are moving vanes built into the suction portion of the fan, which restrict and guide the air flow into the fan. These vanes and dampers restrict the flow area and generate a pressure drop. The increased fan pressure puts more load on the constant speed motor causing a large energy loss.



To avoid the energy loss, the best solution is to remove the dampers to eliminate all flow resistance and control the fan speed. A variable frequency drive, which controls the frequency of the power, is connected to the motor.

This way the motor speed can be adjusted to match the desired fan speed and flow. The energy used is much less than using an output damper to control flow.

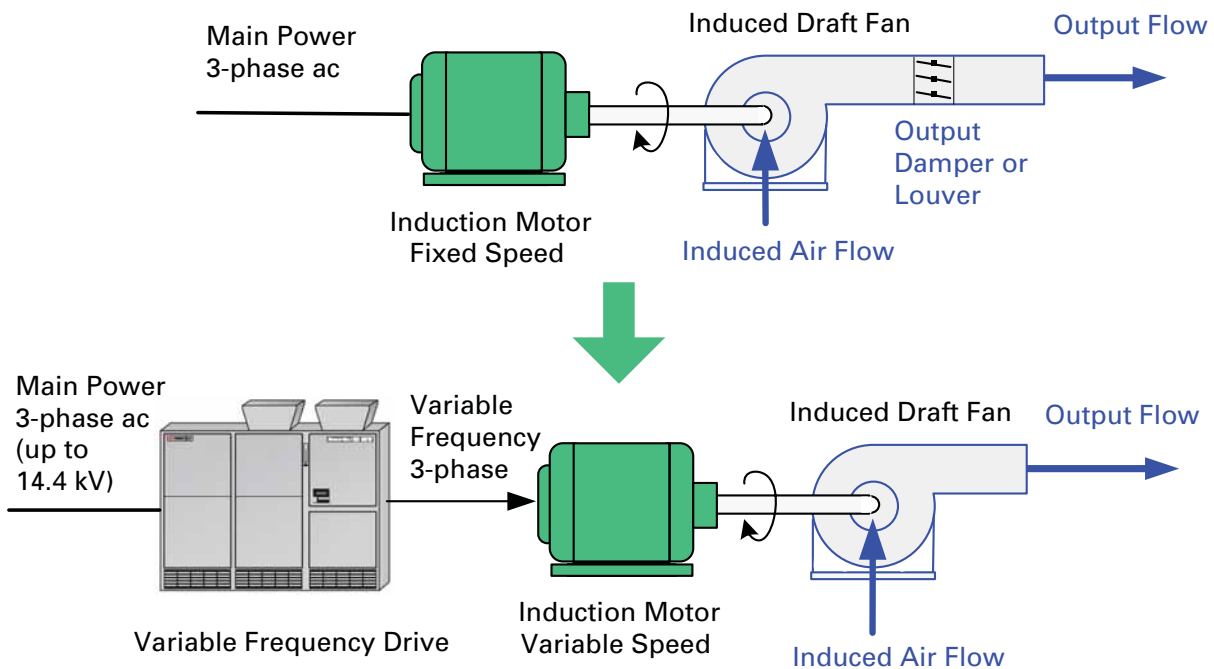

The variable frequency drive solution can save a considerable amount of energy, especially with large motors. For example, a nominal 1,000 hp fan running at 90% speed, savings are worth over \$170,000 per year. The

drive can be easily added to supply power to existing fans, and generally the dampers do not have to be removed but just left open. A typical project has a short payback period based on the energy savings.

PUMP SPEED CONTROL

High-power pumps, such as circulating water pumps and boiler feed pumps, are used in utilities. In older pumping systems, significant energy is lost in the throttling valve, which controls the water flow.

Energy savings can be realized by replacing the flow control valve with a variable frequency drive and motor to power the pump.



The following example is for a pump supplying water to a process, driven by a fixed-speed electric motor. The water flow is controlled with a diaphragm-operated control valve, controlled by a signal from the process control system (PLC or DCS). If less flow is required, the valve is partially closed, which reduces the flow and increases the pump pressure while the pump runs at the same speed. This is called flow throttling, and the pressure drop across the valve causes flow energy to be lost. Also, since the pump is working against a higher pressure, more energy is required from the motor.

The situation is much improved if the motor is supplied by a VFD. The control valve is no longer required since the flow is varied by changing the motor speed. The VFD is supplied by 50 or 60 Hertz 3-phase power and creates a 3-phase output of any desired frequency. The motor changes speed to match the frequency supplied to it, which drives the pump to produce the desired flow.

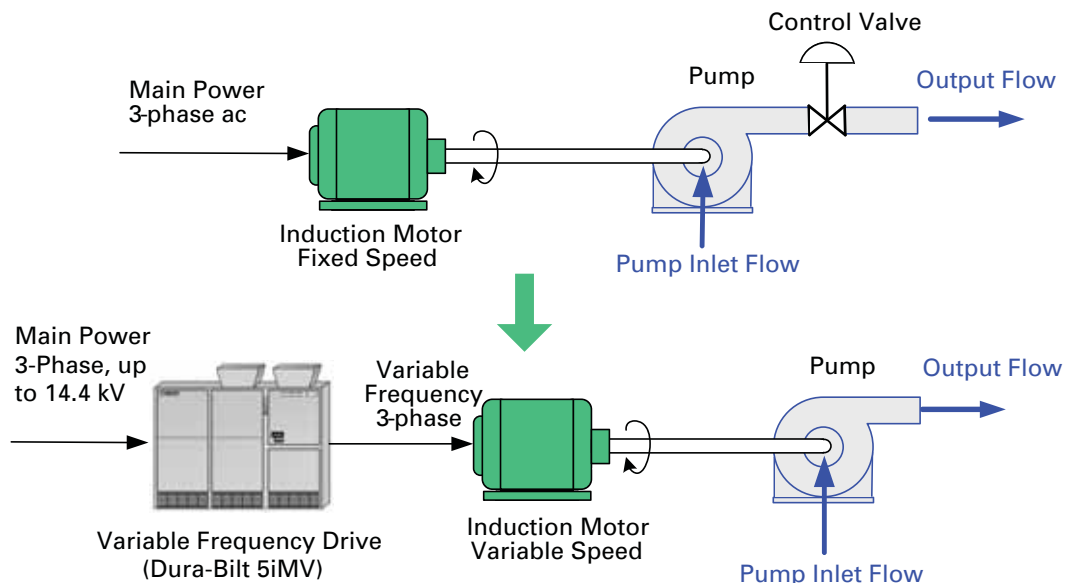

The pump supplies flow against a much lower pressure, so the motor power is much less. The reduced motor power

results in significant energy savings, especially if the reduced flow is required for an extended period.

ENERGY SAVING SYSTEM FOR RUBBERTIRE GANTRY CRANES

The MaxFuelSaver™ RTG energy saving system is installed on Rubber Tire Gantry cranes in a number of ports. The system uses a special diesel engine speed regulator, which interfaces with the existing diesel generator control module (ECM) and optimizes engine speed at every load. The regulator also interfaces with the crane controller, which controls the high-efficiency variable frequency drives connected to the main crane motors.



Control System

The system uses a standard TMEIC TMdrive-10 converter supplying DC power to the constant voltage bus for the crane drives and a standard TMdrive-10 inverter configured as a regenerative power supply to auxiliary loads such as the brakes, pumps, air conditioning, etc. It should be noted the system does not reduce the acceleration time of the hoist.

Main System Benefits

- Reduced crane fuel consumption by optimizing engine speed at every load
- Extended diesel engine life
- Reduced engine emissions and audible noise
- Reduced engine maintenance cost

Energy Savings

Tests on a MaxFuelSaver™ fuel-efficient control on two large rubber tire gantry cranes at the Chinese port of Yantai have yielded impressive energy savings. The tests, conducted on a Tier 3 (low NO_x emission) diesel powered crane over two months, compared an older RTG and the new MaxFuelSaver RTG, and showed diesel fuel savings of 24-42%, depending on operating conditions. As a result, this system generates tens of thousands of dollars per year in fuel cost savings for each RTG. An option to include batteries for regenerative energy storage yields even higher savings.

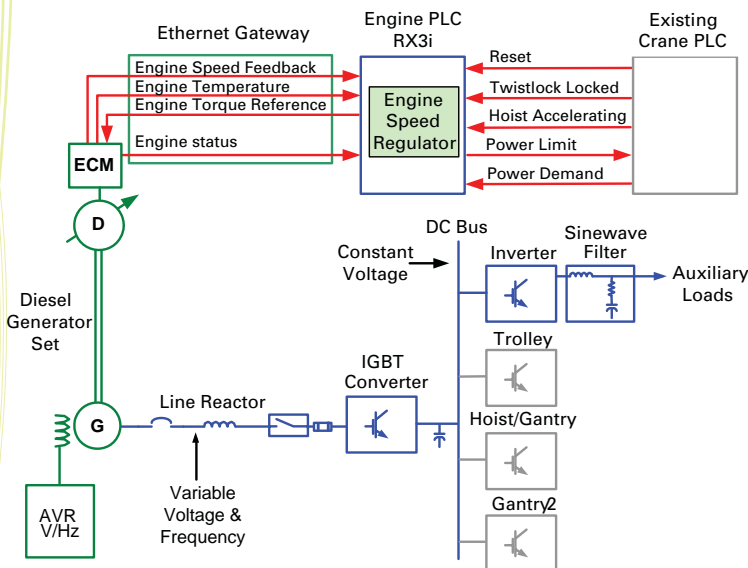



Motors



Automation



Drives

Global Office Locations:

TMEIC Corporation

Office: 1325 Electric Road, Suite 200
Roanoke, VA, United States 24018
Mailing: 2060 Cook Drive
Salem, VA, United States 24153
Tel.: +1-540-283-2000
Fax: +1-540-283-2001
Web: www.tmeic.com
Email: info@tmeic.com

TOSHIBA MITSUBISHI-ELECTRIC INDUSTRIAL SYSTEMS CORPORATION

Mita 43 MT Bldg.
13-16 Mita 3 chome, Minato-ku Tokyo
108-0073 Japan
Tel.: +81-3-5444-3828
Fax: +81-3-5444-3820
Web: www.tmeic.co.jp

TMEIC Europe Limited

6-9 The Square, Stockley Park
Uxbridge, Middlesex, United Kingdom
UB11 1FW
Tel.: +44 870 950 7220
Fax: +44 870 950 7221
Web: www.tmeic.com
Email: info@tmeic.eu

TMEIC Industrial Systems India Private Limited

Unit # 03-04, Third Floor,
Block 2, Cyber Pearl, HITEC City, Madhapur,
Hyderabad, 500081, Andhra Pradesh, India
Tel.: +91-40-4434-0000
Fax: +91-40-4434-0034
Web: www.tmeic.in
Email: inquiry_india@tmeic.com

TOSHIBA MITSUBISHI-ELECTRIC INDUSTRIAL SYSTEMS (BEIJING) CORP

21/F, Building B, In.do Mansion
48 Zhichunlu A, Haidian District,
Beijing 100098, PRC
Tel.: +86 10 5873-2277
Fax: +86 10 5873-2208
Email: sales@tmeic-cn.com

TMEIC is a registered trademark of Toshiba Mitsubishi-Electric Industrial Systems Corporation.

TMdrive is a registered trademark of Toshiba Mitsubishi-Electric Industrial Systems Corporation.

All other products mentioned are registered trademarks and/or trademarks of their respective companies.

All specifications in this document are subject to change without notice. The above brochure is provided free of charge and without obligation to the reader or to TMEIC Corporation. TMEIC Corporation does not accept, nor imply, the acceptance of any liability with regard to the use of the information provided. TMEIC Corporation provides the information included herein as is and without warranty of any kind, express or implied, including but not limited to any implied statutory warranty of merchantability or fitness for particular purposes. The information is provided solely as a general reference to the potential benefits that may be attributable to the technology discussed. Individual results may vary. Independent analysis and testing of each application is required to determine the results and benefits to be achieved from the technology discussed. If you have any questions regarding your project requirements, please contact TMEIC Corporation at 540-283-2000.