



DEPARTMENT OF ARTS, CULTURE, SCIENCE AND TECHNOLOGY

ANNUAL REPORT 2000/2001



www.dacst.gov.za

Mission Statement

To realize the full potential of arts, culture, science and technology in social and economic development, in nurturing creativity and innovation, and promoting the diverse heritage of our nation.

Corporate Goals

The Department will support

- *the arts, culture and heritage, by valuing diversity and promoting economic activity;*
- *the linguistic diversity of our country as a resource in empowering all South Africans to participate fully in their country's social, political and economic life;*
- *the equitable development and preservation, conservation, protection, promotion and making known of our collective history, national symbols and heritage;*
- *the development of science and technology through the enabling mechanism of the national system of innovation, for communities, researchers, industry and government; and*
- *its own transformation and organization ensuring lifelong learning and accessibility to South African citizens.*

**I have the honour of submitting the 2000/2001 Annual Report of the
Department of Arts, Culture, Science and Technology**

A handwritten signature in black ink, appearing to read 'RM Adam', with a horizontal line extending to the right.

Dr RM Adam

**Director-General of the Department of
Arts, Culture, Science and Technology**

English Edition

**This report is also available
in the following languages:**

- Afrikaans
- isiZulu
- Setswana
- Tsivenda

INTRODUCTION	1
INFORMATION ON THE MINISTRY	10
Legislative mandate	19
ARTS AND CULTURE BRANCH	20
ARTS AND CULTURE	21
CULTURAL DEVELOPMENT	25
CULTURAL INDUSTRIES GROWTH STRATEGY	25
Poverty Alleviation	27
Cultural Tourism	35
CREATIVE ARTS AND EDUCATION	38
Arts Education and Training	39
Creative Arts	47
HERITAGE	50
Planning and Evaluation	51
Living Heritage	52
Heritage Institutional Governance	54
Geographical Place Names	55
ARTS AND CULTURE INTERNATIONAL LIAISON	60
Projects with Africa	62
Arts Institutional Governance	65
NATIONAL ARCHIVES	68
The Bureau of Heraldry	74
NATIONAL LANGUAGE SERVICE	76
Language Planning	76
Terminology Coordination	78
Translation and Editing	81



SCIENCE AND TECHNOLOGY BRANCH	86
SYSTEMS, EVALUATION AND RESOURCING	89
RESEARCH AND TECHNOLOGY DEVELOPMENT	98
INTERNATIONAL S&T COOPERATION	104
SCIENCE AND SOCIETY	108
META-INFORMATION	113
SCIENCE AND TECHNOLOGY COORDINATION	114
CORPORATE COMMUNICATION UNIT	116
Communication	118
Events	119
HUMAN RESOURCES MANAGEMENT	122
Information Technology	122
Security and Office Services	123
FINANCIAL MANAGEMENT	136
Financial Control	136
Financial Administration	137
Provisioning Administration	137
Internal Audit	137
Legal Services	138
FINANCIAL INFORMATION	139



*Dr Ben Ngubane,
Minister of the
Department of Arts,
Culture, Science
and Technology.*



*Ms Brigitte Mabandla,
Deputy Minister of
the Department.*

Looking back over the past year there have been notable successes within the very diverse DACST portfolio. These range from the recognition of cultural industries in job creation to large-scale leveraging of international resources in equipment-intensive research programmes. The key challenges for the portfolio as whole have been (i) the development of a cooperative approach to corporate governance (how to play as a team within the performing arts sector or the research sector) and (ii) how to contribute towards and be leveraged by wider government-led programmes in a coordinated manner (fitting into the so-called cluster system).

In the technology sector there are key indicators which we will need to address in the medium term as a country. Some of these are

- The relatively large annual technology balance of payments deficit (R1,5 billion);
- The low number of researchers as a percentage of the workforce (0,07%) in comparison with international norms (Spain = 0,3%, Australia = 0,7%);
- The relatively low percentage of GDP spent on research and development (0,7%, OECD average = 2,15%);

- The extremely low rate of formation of biotechnology companies.

In the area of arts and culture, there are some central issues where government needs to provide leadership:

- The search for a new national artistic identity in the context of relatively static resources;
- The creation of a robust intellectual property framework for artists;
- The translation of theory into action in terms of the contribution of the cultural industries to job creation.

Regarding language the main issue is how to give practical expression to the constitutional requirement for linguistic parity and diversity within an era of globalization and fiscal constraints.

CORPORATE GOVERNANCE

The past year has seen significant changes in how DACST views itself. We are a Department which spends approximately 90% of our roughly R1 billion budget on external rather than internal programmes. The institutions that lie within DACST's



Dr Rob Adam, Director-General of the Department

ambit and that receive subsidies from this 90% range from organizations performing scientific research, to the Pan South African Language Board, to museums and performing arts bodies. To create coherence in an extremely diverse portfolio we have begun to develop a common fabric of institutional governance.

The tendency in the past was to draw a line between the Department and its associated

institutions. What went on beyond this line was none of our business, as long as the very broad policy framework was in place. Recent difficulties (for example at the State Theatre) and triumphs (for example the establishment of the SA Large Telescope) have brought home the advantages of working in an integrated way and the disadvantages of not doing so. The creation of the posts of Chief Financial Officer (at the level of Deputy Director-General) and of Director: Arts Institutional Governance underscores our commitment towards responsible governance within a policy framework and subject to the Public Finance Management Act.

A recent study commissioned by us to determine progress in transformation across our portfolio indicates that since 1994 the average percentage of blacks in senior management positions in science councils has risen from under 4% to 28%. The performing arts institutions are more or less in line with this figure, but the various heritage institutions (with the exception of the Robben Island Museum) do less well. It is imperative that a ring-fenced transformation budget be allocated to deal with this issue in a

coordinated way. Within DACST itself the percentage of black managers is over 70%, which underscores the need for government to play a leading role in the parastatal sector too.

DACST WITHIN THE CLUSTER SYSTEM OF GOVERNMENT

During the 2000/2001 financial year the business of government became increasingly organized into clusters of departments cooperating to achieve aggregate objectives. From the perspective of the Department of Arts, Culture, Science and Technology, the key clusters are (i) the Economic, (ii) the Social and (iii) the International Relations, Peace and Security clusters. Towards the end of 1999 customer-focused business units dedicated to these three clusters were conceptualized. The appointment of key managers to operationalize these units took place during the financial year being reported on. It is still too early to pronounce on the success of this management framework. Nevertheless, it will be used as the basis for describing a range of thrusts (by no means exhaustive), selected to illustrate the work of the Department.

ECONOMIC CLUSTER

The 2000/2001 financial year saw the recognition of both the cultural and the scientific legs of the Department from the perspective of economic strategy.

At the January 2001 Cabinet Lekgotla it was affirmed that cultural industries such as crafts, music and film would in future be embedded in economic programmes from the twin perspectives of growth and job creation. It has become increasingly apparent that the cultural industries can play as important a role in catch-up economies as more traditional industries such as mining and agriculture. Countries as diverse as Sweden and Mexico provide sustained evidence of this.

Also at the January Lekgotla it was affirmed that research and development (R&D), together with infrastructure and human resources, was the key cross-cutting ingredient in economic growth. It is an obvious but infrequently articulated fact that rapidly developing sectors of the economy are more heavily dependent on research than highly evolved and mature sectors. During the past five years we have witnessed the phenomenal impact

of information technology and more recently of biotechnology on the global economy. Clearly the implication is that indigenous R&D in these sectors must be escalated to meet these challenges.

Some of the key programmes that illustrate the work underpinning our contribution to this cluster over the past year have been:

- **Sustaining the national research and development base**

The strong leveraging effect of research and development on economies has been advocated anecdotally for decades. Recently more rigorous arguments based on shadow price calculations on many economies have emerged. The South African

Government's R&D investment portfolio is concentrated in the eight science councils and other instruments such as the Innovation Fund. This portfolio needs continuous monitoring and optimization in terms of local needs and international trends. To assist in this process, appropriate reviews and investigations (e.g. Foresight) in collaboration with the National Advisory Council on Innovation, line departments and research institutions have been carried out. Evidence is that the current annual state investment of approximately R2,5 billion will need to be at least doubled over the next decade (as will the roughly equal private sector figure). Our current national investment of 0,7% of GDP is about a third of the OECD average and (significantly) an even smaller fraction of the equivalent figure for newly industrialized countries such as South Korea and Finland.

- **Technology transfer and diffusion**

Proper utilization of the best available technology is potentially the most important contributor to lowering input costs to the economy. Creating mechanisms through which knowledge and technology can be

transferred to businesses (especially SMMEs) are therefore needed. A programme has been set up involving the establishment of technology stations, technology incubators, technology demonstration centres and innovation support centres that create an environment for the production of knowledge in the context of its application in industry.

- **Promotion of cultural industries**

In the music and craft sector, a range of initiatives have been undertaken with the aim to significantly increase craft and music exports to foreign markets. One such project was initiated early in 2001 in collaboration with the organizers of Celebrate South Africa at the High Commission in London. The impact of developing the craft component of the event created linkages between UK-based craft buyers and South African crafters. Projects such as South African Music Week and South African Design Week generated increased awareness of the importance of these industries and created a platform for project-based industry/government partnerships. In Film, the National Film and Video Foundation has begun to mediate the involvement of the local film industry, government and international players

in co-production agreements. DACST continued to interact with provincial partners and Spatial Development Initiatives (SDI) managers to enhance the potential of cultural tourism to create employment for cultural producers in the three targeted SDI areas, to develop a consistent, revenue-generating link between local artists and the tourism sector.

SOCIAL CLUSTER

The Department's programmes during the 2000/2001 financial year covered a wide span of activities located in the social cluster. These range from the public understanding of science and the establishment of an HIV vaccine programme to the development of a national language policy and the establishment of an oral history programme in the archives. Key flagship initiatives endorsed by Cabinet at the January 2001 Lekgotla lie within the heritage sector. In particular, "symbolic reparation" embodied in Freedom Park is given the highest priority.

- **Conservation and development of heritage**

Heritage is a key component of national identity. South Africa has a well-developed although

skewed heritage infrastructure (i.e. museums, regulatory bodies). The transformation of this infrastructure is important for both economic and cultural reasons.

The amalgamation of five museums in Cape Town (natural history, cultural history and three galleries) and three in Gauteng (natural history, cultural history and military history) has been consolidated and significant efficiency gains have already been realized.

The amalgamation of two long-standing (natural history, cultural history) and one new (Ncome/Blood River) museum in KwaZulu-Natal and three museums (natural history, gallery, military history) in the Free State and Northern Cape is now underway. The consolidation of the SA Heritage Resources Agency (replaces the National Monuments Council) has proceeded according to plan under new management.

The Robben Island Museum has made significant progress over the past three years. To consolidate and build on this progress there is a need for new infrastructure investment. Fiscal constraints indicate a

fundraising route. The Legacy Projects were approved by Cabinet in 1997 to initiate the drive towards a more representative national heritage portfolio. The establishment of the Samora Machel Monument, the Nelson Mandela Museum, the Ncome Monument, the Anglo-Boer War Centenary Commemoration and the Women's Monument has been achieved. In the 2001 - 2002 financial year the development of the Albert Luthuli heritage site and the Khoisan project will be completed and significant progress will have been registered in the establishment of Freedom Park.

- **National Language Plan**

A National Language Plan has been developed and presented to Cabinet. The Plan is informed by the principle of parity between South Africa's 11 official languages as guaranteed by the Constitution. This principle is given practical expression by means of an equitable system of rotation between the languages in official usage. In terms of the Plan, each department is expected to establish a language unit to promote implementation of language

diversity. The cost implications of the Plan are currently being assessed by the National Treasury.

- **Indigenous Knowledge Systems**

Indigenous knowledge is on the one hand a potential source of growth and development. On the other hand it is under threat of unscrupulous international exploitation without compensation to the communities that "own" the knowledge. Ethnomedicine and ethnopharmacology, sustainable utilization of plant, animal and cultural resources by traditional practitioners and the respective industries, indigenous foods, traditional agricultural systems, culture value systems, and commercialization of inventions are key impact areas. A fund to promote research into indigenous knowledge has been placed at the National Research Foundation. Legislation is being drafted under the auspices of the Human Sciences Research Council to promote and protect indigenous knowledge.

INTERNATIONAL RELATIONS, PEACE AND SECURITY CLUSTER

Both the Arts and Culture and the Science and Technology Branches are playing an increasing role in South Africa's international relations. During the 1980s, for somewhat distorted reasons, South Africa had a reputation of technological competence at an international level. To some extent the message that we have retained and even extended this competence has been lost. The Department's involvement in the Celebrate South Africa Campaign in London was therefore conceptualized to embody both cultural and technological dimensions. Our involvement on the International Marketing Council has reinforced the important role that the DACST portfolio can play in

forging the South African "brand". The "wild life, mine dancing and beaches" image sought after by government before 1994 in terms of its tourism strategy has been replaced by a more sophisticated approach which sees tourism and investment as intertwined. Segmentation studies of the international tourism market indicate that culture is possibly

the most important drawcard, and a reputation for technological innovation is a clear winner in terms of investor confidence.

How have these ideas translated into action during the past year? Some examples are:

- **The Hidden Edge**

Minister Ngubane commissioned a book to be written on South Africa's technological innovations. The result was "The Hidden Edge", published by the Engineering Association of South Africa. "The Hidden Edge" is being used in a range of imaging contexts, including "Celebrate South Africa".

- **The Southern African Large Telescope (SALT)**

SALT will be the largest telescope in the Southern hemisphere. The international consortium consisting of institutions in Germany, the United States of America, Poland, the United Kingdom and New Zealand launched the construction of SALT at Sutherland in September 2000. First light will be in 2004.



*Model of
South African Large
Telescope (SALT).*

During the past year a more sophisticated strategy has emerged in terms of aligning South African interests with those of our international partners. For example, significant assistance with respect to technology transfer to small businesses is being obtained from the European Union, whereas our engagement with India is based on crafts, developing our film industry and on information technology and indigenous knowledge systems. In the case of the Russian Federation, we are beginning to tap into the huge reservoir of scientific human resources that country has to offer. In the case of SADC countries, it is crucial to examine our resources and technological needs holistically. This approach has been extended to the countries involved in the Millennium Africa Recovery Programme (MAP), where a scientific exchange programme is being set up to optimize and conserve the continent's scientific human resources in the context of increasing global mobility and the consequent threat of a brain drain.

TRANSFORMATION OF THE DEPARTMENT

A very solid top management structure is being developed in the Department, led by the Minister,

Deputy Minister and Director-General. A system of regular management meetings and a system of reporting are in place and the human resource management portfolio has received vigorous attention as a result of the actions of a new HR management team. As the Human Resources report indicates, all management representativity targets have been met.

MAIN OPERATIONAL GOAL FOR THE NEW FINANCIAL YEAR

We believe that the key goal for all sectors (science, arts, heritage, language) covered by DACST will be to build an integrated management approach based on shared interests, a common vision and mutual respect and loyalty.

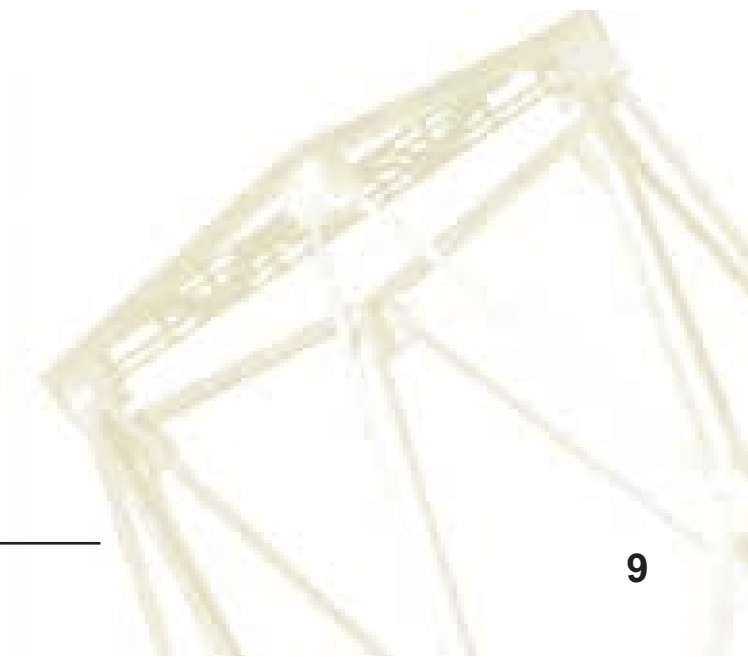



*Dr Ben Ngubane, Minister of the
Department of Arts, Culture, Science
and Technology.*



*Ms Brigitte Mabandla, Deputy
Minister of
the Department.*



There are a number of entities that were declared Cultural Institutions by the Minister of Arts, Culture, Science and Technology in terms of the Cultural Institutions Act, 1998, and which report to the Minister.

PUBLIC ENTITIES

These institutions must formulate policy to receive and preserve all property, of whatever kind, in their care, including specimens, collections or other movable property. They must also manage any movable property that belongs or has been given to government or the people of South Africa.

The following public entities currently report to the Minister of Arts, Culture, Science and Technology:

- Northern Flagship Institution
- Southern Flagship Institution
- Natal Museum, Pietermaritzburg
- National Museum, Bloemfontein
- Die Afrikaanse Taalmuseum, Paarl
- The National English Literary Museum, Grahamstown
- Voortrekker Museum, Pietermaritzburg
- War Museum of the Boer Republics, Bloemfontein
- Robben Island Museum, Cape Town
- William Humphreys Art Gallery, Kimberley
- Engelenburg House Art Collection, Pretoria
- Nelson Mandela Museum, Umtata
- National Zoological Gardens of South Africa
- Foundation for Education, Science and Technology

Eleven other institutions, some governed by their own Acts, also report to the Ministry:

SOUTH AFRICAN HERITAGE RESOURCES AGENCY

The South African Heritage Resources Agency was established in terms of the National Heritage Resources Act, 1999. Its aims include introducing an integrated and interactive system of the national heritage resources and empowering civil society to conserve its heritage resources for future generations. It established the South African Heritage Resources Agency, which together with its Council, coordinates and promotes the management of heritage resources at national level.

ARTS INSTITUTIONS

Arts institutions (in terms of section 21 of the Companies Act, 1973) assist in creating a sustainable performing arts industry based on access, excellence, diversity and redress. They encourage the development of the full range of performing arts. The

institutions include:

- State Theatre
- KwaZulu-Natal Performing Arts Company
- Artscape
- Market Theatre
- Performing Arts Council of the Free State

BUSINESS ARTS SOUTH AFRICA

Business Arts South Africa is a Section 21 company aimed at encouraging sponsorship of the arts by the business sector through the introduction of a matching grant scheme.

NATIONAL FILM AND VIDEO FOUNDATION

In terms of the National Film and Video Foundation Act, 1997, the Foundation develops and promotes the film and video industry. It provides and encourages the

provision of opportunities for persons from disadvantaged communities to participate in the industry. The Foundation also promotes local film and video products, supports the development of and access to the industry, and addresses historical imbalances in infrastructure, skills and resources in the industry.

NATIONAL ARTS COUNCIL

In terms of the National Arts Council Act, 1997, the Council facilitates opportunities for people to practice and appreciate the arts. The Council also promotes general application of the arts in the community, fosters the expression of a national identity by means of the arts, promotes freedom in the practice of the arts, and gives historically disadvantaged people greater access to the arts. Other functions include addressing historical imbalances in the provision of infrastructure and promoting national and international liaison.

NATIONAL ARCHIVES COMMISSION

The National Archives Commission advises the Minister on any matter related to the National Archives Commission Act, 1996. The Commission

also assists the National Archivist in carrying out the functions of the National Archives, promotes the coordination of archival policy at national and provincial levels, approves the appraisal policy of the National Archives and monitors its implementation. The Commission maintains a national list of non-public records in South Africa.

PAN SOUTH AFRICAN LANGUAGE BOARD

The Board actively promotes an awareness of multilingualism as a national resource, and supports the previously marginalized languages by developing, administering, and monitoring access, information and implementation programmes. These activities are in accordance with the provisions of the Pan South African Language Board Act, 1999.

State Archives, Hamilton Street, Pretoria. An official receives an archives group from a client office.



HUMAN SCIENCES RESEARCH COUNCIL (HSRC)

The Council provides for the promotion of research and the extension of knowledge in the field of the human sciences in terms of the Human Sciences Research Act, 1968. During the period under review the HSRC's core business was sharpened with the integration of its former Centre for Science Development with the Foundation for Research Development (resulting in the formation of the National Research Foundation), and by the transfer of its Centre for the Evaluation of Educational Qualifications to the South African Qualifications Authority. In addition, two research units - Psychological Assessment Instrument Development, and Education and Training Assessment - were consolidated in order to achieve greater synergy.

NATIONAL RESEARCH FOUNDATION (NRF)

The Foundation provides for the promotion of research, both basic and applied, and the extension and transfer of knowledge in the

field of science, technology and indigenous technology, in terms of the National Research Foundation Act, 1998. During the course of the period under review the NRF underwent a serious restructuring exercise. This included both structural alterations to the building to accommodate former HSRC staff relocated in terms of the mandate the institution acquired following the demise of the former Foundation for Research Development (FRD) as well as the formulation of a new research support strategy. The NRF has responsibility for strategic and administrative oversight of national facilities, namely the South African Astronomical Observatory, the Hartebeeshoek Radio Astronomy Observatory and the National Accelerator Centre. Responsibility was acquired for a new national facility, the JLB Smith Institute of Ichthyology.

AFRICA INSTITUTE OF SOUTH AFRICA

The Africa Institute is a Section 21 company that carries out in-depth analysis of Africa's current affairs and addresses issues of the future of the continent, the African Renaissance and change in general.

NATIONAL LASER CENTRE (NLC)

The NLC was created from laser competencies at both the CSIR and the Nuclear Energy Corporation of South Africa. Its goal is to promote South African competitiveness in the area of lasers, particularly with regard to application in manufacturing, telecommunication, health, and safety and security.

INNOVATION FUND TRUST

The Innovation Fund Trust was established in April 2000 with the objective of giving strategic direction on the Innovation Fund. The Innovation Fund is one of the Science and Technology White Paper (1996) initiatives and was designed to encourage collaborative research and technology development programmes, requiring a multidisciplinary approach to problem solving to address problems/challenges serious enough to impede socio-economic development or affect our ability to compete in products and services. Projects are supported in the areas of Biotechnology, Advanced Materials and Manufacturing, Value Adding to SA indigenous fauna and flora, and Information and Communications Technology.





State Archives, Hamilton Street, Pretoria. An official, Miss A Simelane looks at a map in the map strongroom.

LIBRARIES

Libraries preserve and promote awareness of the national documentary heritage, and provide for matters connected therewith. They include the South African Library for the Blind, which provides library and information services to blind and print-handicapped readers, and for matters connected herewith. The institutions include:

- National Library
- South African Library for the Blind

- South African Blind Workers' Organisation (Section 21 company).

BILLS SUBMITTED

The Minister submitted three Bills to the Legislature during the report period, i.e.

- Cultural Laws Amendment Bill
- Cultural Laws Second Amendment Bill
- National Council for Library Information Services Bill

OFFICIAL VISITS ABROAD

Minister BS Ngubane

Dates	Countries visited	Purpose
7 - 14 April 2000	Cuba	Non-aligned summit
7 - 12 May 2000	Canada	Commonwealth Science Council
19 - 26 May 2000	Greece and Spain	Ministerial Network on Cultural Policy
21 - 29 June 2000	Paris and Germany	OECD Conference & Commonwealth Science Council
11 - 22 July 2000	Israel, Palestine and France	Commemoration of South Africans who fought in Second World War
20 - 30 September 2000	Algeria	SA-Algeria Binational Meeting
27 - 29 September 2000	Greece	Ministerial Network on Cultural Policy & Commonwealth Science Council
24 - 26 October 2000	Hong Kong, China and Japan	Binational Meetings
12 - 17 November 2000	London and France	Commonwealth Science Council & UNESCO Meeting
28 November - 2 December 2000	Mozambique & Mexico	SADC Ministers Meeting & Inauguration of newly elected Mexican President
10 - 13 December 2000	France	Olympiad of the Mind
28 February - 4 March 2001	Jamaica	Commonwealth Science Council
10 - 18 March 2001	India & United Arab Emirates	Binational Meetings & meeting with Minister's counterpart
24 - 31 March 2001	Cuba	Accompanying President Mbeki

Deputy Minister, BS Mabandla

Date	Countries visited	Purpose
22 - 29 March 2000	China and Japan	Accompanied the Minister of Foreign Affairs to strengthen cultural ties between SA and the two countries
25 April - 4 May 2000	USA	Youth stabilization and development; delivered speech during Freedom Day celebrations in Washington and met with the University of Michigan to discuss the training of museologists
3 - 9 September 2000	Singapore and India	Meeting with stakeholders in Arts and Culture with emphasis on Indigenous Knowledge Systems and Film
13 - 19 September 2000	France and Belgium	Attended the Caen International Trade Fair and met with the EU in Brussels to discuss the EU-SA Film Summit
25 - 30 September 2000	Greece	International Network on Cultural Policy
11 - 14 March 2001	Nigeria	SA-Nigeria Binational Commission

Legislative Mandate

The following Acts are administered by the Department:

- National Archives of South Africa Act
- Heraldry Act
- Woordeboek van die Afrikaanse Taal Act
- Pan South African Language Board Act
- Human Sciences Research Act
- Natural Scientific Professions Act
- Culture Promotion Act
- National Arts Council Act
- National Film And Video Foundation Act
- Legal Deposit Act
- National Advisory Council on Innovation Act
- The SA Geographical Names Council Act
- Cultural Institutions Act
- Culture Promotion Act
- National Library for the Blind Act
- National Library of South Africa Act
- National Research Foundation Act
- National Heritage Council Act
- National Heritage Resources Act
- National Advisory Council on Library Information Services Act





The Women's Monument was unveiled by President Thabo Mbeki on 9 August, 2000.

MISSION STATEMENT

The Arts and Culture Branch of the Department aims to ensure equal opportunities to all South Africans for artistic and cultural participation and expression, to conserve and promote the heritage of all people of the country and the film industry of the RSA, and to promote cultural relations internationally.

The Branch facilitates equal opportunity for artistic and cultural participation through ensuring a rational policy and institutional framework such as the National Arts Council (NAC) for financing appropriate artistic organizations. Different programmes provide financial assistance to declared institutions such as museums and heritage and conservation bodies like the South African Heritage Resources Agency.

In the light of the sizeable property portfolio managed on behalf of the Department by the different institutions, the Arts and Culture Branch also comprises a strong capital works budget which is aimed at the maintenance of infrastructure of the arts and culture institutions.



*Mr Themba Wakashe
Deputy Director-General
Arts and Culture*

STRATEGIC DIRECTION

There are six main areas that are imperative in defining the strategic direction of the Branch. These are Arts Institutional Governance, Cultural Development, Heritage, International Liaison, National Language Service and National Archives. Important issues are the delivery of services and more alignment in the budgeting controls for the institutions in the arts and culture sector. In addition to this, DACST is developing more structured complementary activities for the promotion and enhancement of cultural tourism in the country. Human Resources Development, in particular the training of arts managers and administrators for the associated institutions, continues to receive urgent attention.

Since the cultural industries are embedded in the core of the government strategy for development, DACST will be focusing attention on this sector. This means developing public and private partnerships, creating a framework for the development of export councils, as well as delivering to the music and film industries, two key economic drivers for the cultural industries.

The conservation and promotion of heritage provides a platform to create a balanced representation in the cultural landscape of South Africa. The development of a national plan for the rejuvenation of museums in the areas of programming, exhibitions, service delivery and educational programmes is another area of focus with a potential for vibrant programmes in the portrayal of South African heritage.



*Mr Frans Basson
Chief Director: Arts and Culture
Branch Coordination*

BRANCH OBJECTIVES

- To develop the economic potential of arts and culture, thereby alleviating poverty.
- To develop the creative potential of the arts through education and training and support for a wide range of arts activities.
- To create sustainable performing arts industry based on access, excellence, diversity and redress, to encourage the development and to celebrate the full range of South Africa's performing arts heritage.
- To create access to the arts especially for the previously disadvantaged communities: gender equality, the youth and the disabled.
- To foster a national identity and the protection of rights by preserving a national archival and audio-visual heritage for the use of the people and government of South Africa at a national level.
- To promote an efficient, accountable and transparent government through the proper management and care of government records.
- To promote multilingualism and language development and manage language diversity through language policy and planning activities.
- To ensure equitable development and preservation, conservation, protection, promotion and making known of our collective history, national symbols and heritage:
- To develop a standardized operational framework for the Boards of performing arts institutions.
- To ensure South Africa's presence in the international arena of arts and culture, and service bilateral and multilateral agreements, as well as facilitating exchanges emanating from these agreements.

Arts and Culture

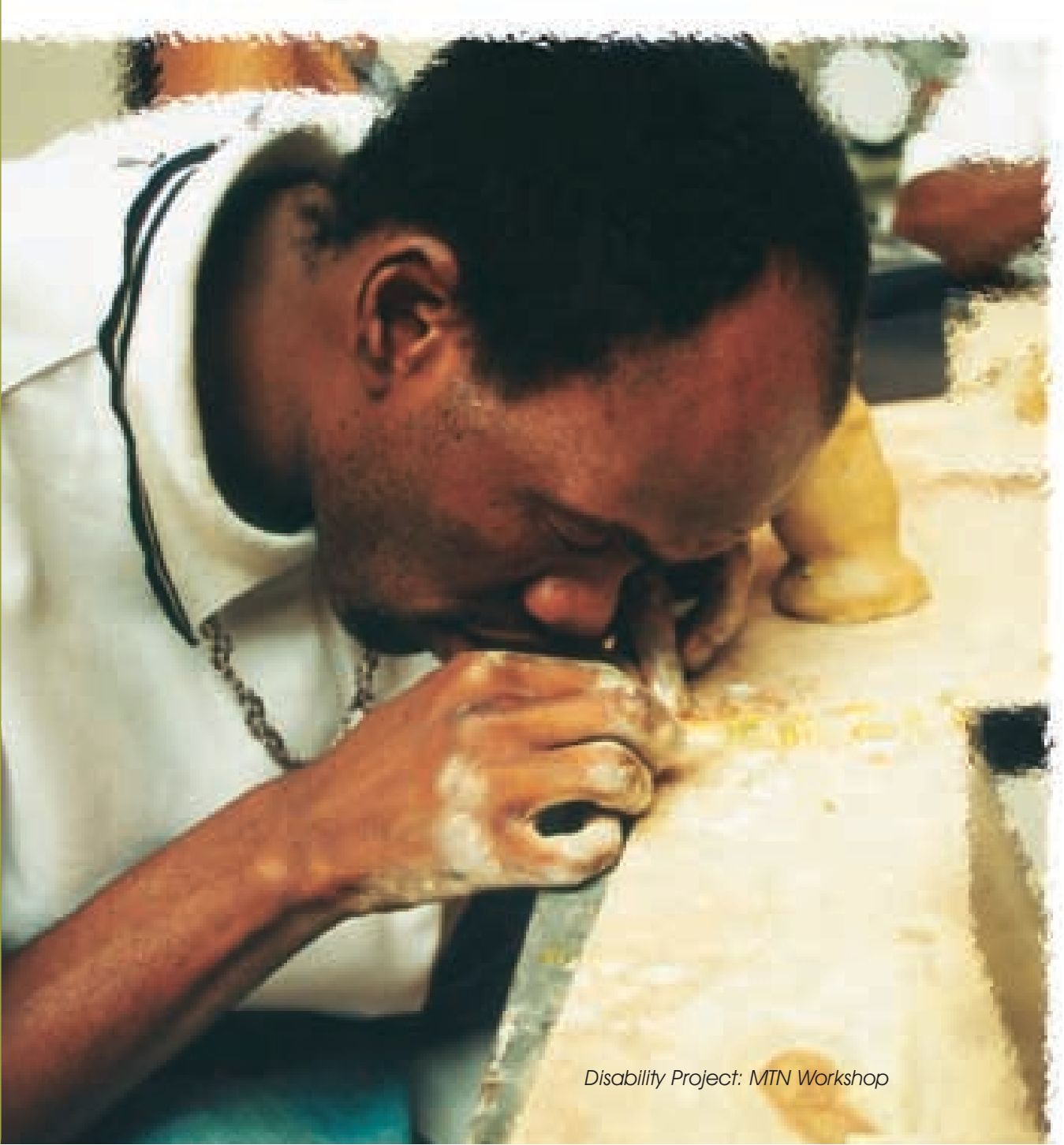

Arts and Culture

CULTURAL DEVELOPMENT

CULTURAL INDUSTRIES GROWTH STRATEGY

Policy developments

The Cultural Industries Growth Strategy (CIGS) was initiated in 1997 to investigate and capitalize on the potential of the craft, music, film and television, and publishing industries to contribute positively to the development of the South African economy. After two years of intensive research, it became clear the areas where government intervention would yield the greatest impact were:

- The development of public private partnerships.
- The creation of a coherent and coordinated education and training environment.
- Market development.
- Advocacy projects for the four industries.
- Research.
- The utilization of culture as a tool for urban regeneration.

Over the past two years the Department has initiated a number of important processes and supported projects that include:

- The Music Industry Task Team process.
- The establishment of the Print Industry Cluster Council.
- South African Music Week.
- Laying the foundation for the development of export councils in the cultural industries.
- Identifying strategic opportunities for exporting craft products at venues such as SIAO in Burkina Faso, and Celebrate South Africa in London.
- Supporting the National Craft Development Initiative.
- Conducting research that includes the development of a handbook for crafters, a feasibility study into glass bead manufacturing and an impact assessment of South African music week.

The Department has broadened the CIGS focus to include strategic partnerships in cross-cutting

Arts and Culture



*Mr Steven Sack
Director: Cultural
Development*

national policy areas working closely with other government departments in areas such as:

- Poverty Alleviation,
- Urban Renewal through the arts,
- Amendment of copyright legislation in collaboration with the Department of Trade and Industry (DTI),
- Sector Skills Development for Arts and Culture as part of the SETA Process, led by the Department of Labour, and
- Complimentary intervention in the Design Sector

Cultural Industries Research

DACST commissioned significant studies in the area of cultural industries. The original Cultural Industries Growth Strategy (CIGS) Reports were completed in 1998. These became base documents for the economic value of the cultural industries in South Africa. The company KPMG launched their study, "The South African Music Industry Facts - Trends - Future", at the beginning of SA Music week in August 2000.

The Department also commissioned a study by PricewaterhouseCoopers on the potential of the South African film industry. The results of the study, titled "Profile 2000 - Towards a viable South African Film Industry", were announced in November 2000 during the SA-EU Film Symposium, which was held in Johannesburg.

Music Industry Task Team Report

In March 2000 Dr Ben Ngubane, Minister of Arts, Culture, Science and Technology, appointed the Music Industry Task Team (MITT) to investigate issues pertaining to the music industry and to advise him on how to address these challenges.

Arts and Culture

The Task Team had the following brief:

- To receive written submissions from stakeholders, consult and recommend to the Minister various strategies that can be adopted to address the problems of the industry;
- To examine the adequacy of the legislative framework governing the industry and to make recommendations;
- To appraise the various systems, such as contracts with musicians, piracy, recording, distribution, publishing of music, royalty collection and distribution, "needle time", etc. and identify actions which will address problem areas;
- To advise on what the role of government should be regarding the music industry; and
- To advise on any other action that will assist in developing the music industry.

Public hearings were held in Johannesburg, Durban, Cape Town, Port Elizabeth, Bloemfontein and Pietersburg. Following the consultative process a report was drafted and handed to the Minister. DACST has already initiated processes to address

some of the priority areas which came out of the MITT recommendations.

Poverty Alleviation

In 2000 DACST was for the first time allocated funding from the Poverty Alleviation Programme by the National Treasury. There is an emerging realization, both in South Africa and in the rest of the world, that culture has a critical role to play in development whether through sustaining built and lived heritage, encouraging the contemporary cultural industries or recognizing the impact that culture has in defining identity and fostering a sense of empowerment. The benefits of culture as a tool for development are numerous, but can be summarized as follows:

- Employment can be created at a relatively low cost.
- Culture has the potential to develop identity and community ties among South Africans.

Arts and Culture



Thandi Gam of the Philani Flagship project in Cape Town showcasing textile prints.

- Culture is a clean industry.
- Creating opportunities for revenue generation employment in culture is sustainable.
- Culture has the potential to develop "liveable" communities.
- Projects that promote indigenous art forms
- Projects that promote cultural performances and cultural festivals in rural areas as stimulants for cultural tourism activities
- Projects that provide business training for cultural practitioners
- Projects that develop community-based infrastructure such as resource centres, cinemas and small batch production units that will enhance the social and economic aspects of communities

Targets

The aspect of human resource development, as well as training in product development and business skills, was regarded as a critical component in all the projects.

The following categories of projects were identified for funding:

- Craft development projects
- Music development projects

Projects

The following projects were funded from the R9 million received by DACST for Poverty Alleviation:

Arts and Culture

CULTURAL INDUSTRIES DEVELOPMENT	
Project	Description
KhumbulaZulu Craft	This project focused on the top-quality reproduction of traditional Zulu crafts such as beadwork, woodcarving, metal work, wirework, basketry, shield making, bone and horn carving and pottery.
CSIR projects	The CSIR was appointed to formalize craft production into manufacturing units and also to provide a niche for craft development in communities. The projects encompassed a number of processes: <ul style="list-style-type: none"> ● Product development ● Business training ● A historical exhibition of crafts of the Northern Province
Eastern Cape Special Project	This project was located at the PE Technikon and involved the students of the Technikon in skills development linked to income generation.
Northern Cape Craft Feasibility Study	Following the craft audit in the Western Cape, a similar study was undertaken in the Northern Cape. The study examined the situation in the province in relation to the infrastructure available, the products, equipment and materials utilized, the training programmes and the markets
Recording facilities at Playhouse, Durban	State-of-the-art recording equipment was installed at the Playhouse to encourage recording artists to record locally instead of going to Johannesburg and also to give lesser known artists the opportunity to record their music for promotion purposes.
Apollo Theatre	The existing 1950s Apollo Cinema in Victoria West was restored and developed into a cinema, museum and tuckshop. The youth of the town are responsible for the running of the theatre.

Arts and Culture



Alson Zuma with his burnt-decorated wood carvings, which he displayed in the tent at the Celebrate South Africa event in London.

CULTURAL TOURISM

Research conducted by DACST in 1998 into opportunities for cultural tourism in the Lubombo, Wild Coast and Maputo Corridor SDIs provided the base for developing these projects.

Project	Description
Lubombo, Maputo and Wild Coast Cultural Tourism development projects	A range of activities aimed at facilitating culturally based social and economic activities were undertaken. These included the entertainment, education and capacity building of local inhabitants, as well as job creation and facilitating sustainable cultural tourism economic activities. Cultural performances and festivals were organized.
African Cuisine Project	The Mpumalanga Parks Board initiated this project whereby vendors will sell a limited number of typical African foods to tourists.

Arts and Culture

HERITAGE INFRASTRUCTURE DEVELOPMENT

There is much evidence that heritage and museum developments can play a significant role in plans for economic development, whether as part of general tourism initiatives, or more specifically in relation to the regeneration of regions of great industrial decline and change.

Project	Description
Khoi-San Community Legacy Project Feasibility Study	DACST proposes to develop two or three centres that provide infrastructure to rural communities, facilitate human resource development and link to national projects such as the promotion of heritage and tourism. The location of the resource centre has been assessed through a thorough front-end study undertaken by the Institute for Historical Research at the University of the Western Cape. The study took into consideration issues such as viability, tourism impact, and service provision to the poorest of the poor.

BASIC BUSINESS SKILLS TRAINING

Project	Description
IMM Training	Participants underwent training in business skills and marketing at the IMM. In turn the trainees were paid to impart their learning to other members of the community.

Arts and Culture

Further funding

In December 2000 DACST was allocated further funding for a period of three years for projects that have the potential to create jobs and reduce poverty.

Craft Export Council

DACST proposed in 2000 that a partnership with the Department of Trade and Industry (DTI) be formed to facilitate a process to

establish a craft export council in 2001. An allocation of R200 000 will be made available in the 2001/2002 financial year to assist this process.

- **The Northern Province Special Project (NPSP)**

The NPSP is a special presidential rural development project that aims to use crafts and heritage and linking it to a tourism development strategy.

Nelson Mathonsi of the Nukain Mabuza Memorial Project in Mpumalanga demonstrating his skill at the Bernie Spain Gardens - Thames River London, during the "Celebrate South Africa" event.



Department of Arts, Culture, Science and Technology

Arts and Culture

Selected crafts projects in the Northern Province are receiving training in areas such as product development and quality control, business management, and market access and marketing through the Council for Scientific and Industrial Research (CSIR).

- **Information Handbook for crafters**

DACST appointed the National Craft Council of SA (NCCSA) through a tender process to develop a user-friendly craft information handbook and craft directory. The handbook aims to address the problem of access and difficulty in accessing information for crafters.

- **Glass Bead Manufacturing Facility**

DACST contracted the CSIR to do a feasibility study on the establishment of a glass bead manufacturing facility here in South Africa. The study was completed and submitted to DACST. The conclusion reached was that it is both necessary and feasible to establish such a facility. DACST, the CSIR and the Industrial Development Corporation (IDC) hosted a presentation where these findings were publicized and business proposals called for.

- **The 7th International Arts and Crafts Trade Show of Ouagadougou (SIAO 2000)**

DACST coordinated South Africa's first participation in the Arts and Crafts Trade Show of Ouagadougou (SIAO 2000). Fifteen crafters representing a variety of craft genres were taken to SIAO to showcase and promote South Africa's crafts.

The South Africa Stand won second prize for the overall best country stand. A ceramist from the Potter's Shop in Cape Town won second prize in the pottery division and the Zulu baskets made by the Ndwandwe family in KwaZulu-Natal won first prize in the basketry division in the special creativity exhibition.

- **Beadwork and Embroidery Project and Craft Mobile Clinic (Mpumalanga)**

The Mpumalanga Provincial Government through the Crafts and Visual Arts Section submitted a proposal to DACST requesting assistance to equip and develop a mobile craft clinic. Through the craft mobile clinic the Craft and Fine Art Section is conducting craft and art workshops to Mpumalanga crafters in outlying rural areas.



Minister Ngubane at the Craft Exhibition at the Wild Coast Cultural Festival.



Craft Exhibition at the Wild Coast Cultural Festival.

Arts and Culture

Furthermore, the provincial government was able to secure a contract with the architect of the new Mpumalanga Government complex. A group of 60 women were trained in beadwork, embroidery, colour combination and quality control to produce a textile panel on the history of Mpumalanga Province. The textile panel now hangs in the newly built Mpumalanga Legislative Assembly building.

- **ATA Market Readiness Training**

DACST provided R25 000 to fund two craft practitioners to attend the Aid to Artisan's (ATA) Market Readiness Training programme in the USA. ATA are renowned for their work with craft organisation, particularly in developing countries. Their expertise ranges from product development, quality, European and American market trends, marketing, business skills and management.

- **Celebrate South Africa**

DACST was involved and supported the Celebrate South Africa event in London for the international promotion of South Africa's art and culture, and craft and technology. This event achieved significant notice and positive imaging for South Africa.

Arts and Culture

CULTURAL TOURISM

Wild Coast Spatial Development Initiative (SDI), Eastern Cape

DACST made available R500 000 for the capacity development of performers and crafters and the

implementation of a cultural festival. Thirty crafters underwent intensive training in business management, skills and product development for 10 days. Performers underwent 20 days of training and formed a production ensemble.

The Wild Coast Festival was held on 6 and 7 April 2001 at Port St Johns.



Arts and Culture

*Edna Nxcongo -
KwaZulu Natal palm leaf.*



Lubombo Spatial Development Initiative (SDI)

DACST made available R850 000 for the development and promotion of cultural tourism in the Lubombo SDI, Northern KwaZulu-Natal. The programme involves training of crafters, music groups and cultural dancers.

Crafters were selected for a training and mentorship programme that lasted 12 months. The highlight was on 6 and 7 April during the craft convention. Several craft buyers and dealers were in attendance. Crafters sold their wares, secured orders and made deals. The convention will be an annual event focusing on crafters from the mentorship programme.

Maputo Corridor

DACST made R850 000 available to the Mpumalanga Provincial Government for the purpose of developing cultural tourism projects. Satellite festivals were held in different regions of the province between October and

Arts and Culture



December 2000. The best groups and individual artists performed at a two-day main festival in Badplaas in February 2001.

Policy developments relevant to cultural industries

In December 2000 the government identified cultural industries as a key sector for economic growth and job creation. The crafts, film and music industries have been targeted and will receive special attention.

Cultural Industries Growth Strategy - Projects

SA Music Week

The model created by South African Music Week has proved to be a successful mechanism to draw various stakeholders into collaborative projects aimed at the broader development of the music industry. DACST will continue to support South African Music Week on the grounds that it draws industry together towards a common goal and promotes sales of South African music.

Print Industry Cluster

The Print Industry Cluster has proved to be a successful medium for the development of the print industry. The Cluster has successfully organized working groups that have initiated projects and secured wider support of the industry.

Urban Regeneration through the arts

GIS System - Mapping creative South Africa

DACST commissioned the HSRC to develop a map and database of cultural infrastructure in the public, private and community sectors. This will be available to the public in September 2001.

International Network on Cultural Policy (INCP)

The INCP is an initiative of cultural ministers from countries all over the world. Cultural diversity has been identified as a critical issue that faces the development of culture both globally and at a national level. South Africa has participated in the working group of officials that was formed to take the development of international policy on cultural diversity forward. DACST will be hosting the gathering of the INCP in September 2002.

Creative Arts and Education



Creative Arts and Education

ARTS EDUCATION AND TRAINING

Policy Developments

The Subdirectorate: Arts Education and Training is a new component and during 2000/2001 the identification of key developmental issues affecting the sector as well as the training needs were prioritized. Consultants [Succinct] were appointed to assist in facilitating and defining a skills development strategy and process for arts, culture and entertainment and their recommendations were submitted to DACST and the Media, Advertising, Print, Paper and Packing Sector Education and Training Authority [MAPPP-SETA] for implementation. The project deliverables included:

- The scoping of community development projects in the sector
- The scoping of employers and employees in the sector
- The scoping of providers in the sector
- The facilitation and development of sector skills plans

- Recommendations on demand-driven learnerships and skills development programmes
- Recommendations on other growth and development initiatives
- Networking and liaison with SAQA, SARS and the applicable SETAs
- Tabling concerns and recommendations

Training Needs Prioritized

The Succinct Report articulated and prioritized workplace training needs for the Creative Industries. The table below identifies the possible skills programmes extracted from the input they received during the sessions they facilitated around the country, as well as needs that emerged from the research into national priorities and from discussions with strategic players in the sector.

Creative Arts and Education



*The Mason Lincoln Identity
Photo Workshop.*

HIGH DEMAND (Required by 7 - 9 sectors)	MEDIUM DEMAND (Required by 3 - 5 sectors)	LOW DEMAND (Required by 1 - 2 sectors)
ABET	Packaging and Presenting	Public Relations
Literacy	Fundraising	Quality Assurance
Computer Skills	Financial Skills	Customer Service
Marketing Skills	Contracting and Copyright	Negotiation
Business Skills	Entrepreneurial Skills	
Management Skills across all sectors with an elective component that deals with the context of those skills	Assertiveness Skills	
Product development and design	Audience Development	
Audience Analysis	Proposal writing and pitching	
	Mentoring and Coaching	

In determining which learnerships should be prioritized, the following criteria were applied:

- Job creation possibilities
- Contributions to the economy
- The export potential of a product inflow of foreign exchange

Creative Arts and Education

The following learnerships emerged from the research:

DISCIPLINE	SUGGESTED LEARNERSHIP TITLE
FILM AND VIDEO PRODUCTION	<ul style="list-style-type: none"> ● Television Studio Operations ● Technical TV Operations ● TV Engineering
CONTEMPORARY MUSIC	<ul style="list-style-type: none"> ● Artist Management ● Music Management ● Music
MUSIC	<ul style="list-style-type: none"> ● Orchestra
DANCE	<ul style="list-style-type: none"> ● Marketing/Research Management ● Choreographers ● Production Management ● Technical Management ● Director of Dance Company
LIVE EVENTS	<ul style="list-style-type: none"> ● Theatre Administration ● Production Management ● Theatre Management
TECHNICAL SUPPORT	<ul style="list-style-type: none"> ● Technical Support· Lighting Design ● Rigging
DESIGN	<ul style="list-style-type: none"> ● Jewellery Design
CRAFT	<ul style="list-style-type: none"> ● The business of craft ● Arts and Craft Management
VISUAL ART	<ul style="list-style-type: none"> ● Curators/Directors of Art Galleries ● Gallery Management
CREATIVE LITERARY ART	<ul style="list-style-type: none"> ● Page layout ● Reproduction ● Proof-reading and editing ● Creative Writing

These findings will be used by DACST and MAPPP-SETA to motivate for funding from the National Skills Fund for training in the Creative Industries.

Creative Arts and Education



The Deputy Minister, Ms B Mabandla, visits the Visual Arts Studio in Durban.

Disability Programme

Having realized that the Department has been silent and relatively inactive in the area of Disability, the Department started engaging various Disabled Peoples' Organizations (DPOs) and the Office on the Status of Disabled Persons(OSDP) early in 2000. To ensure that this area was not neglected, a sum of R600 000 was budgeted.

Through collaboration with the sector and its representatives the original idea of celebrating only 3 December (International

Day of the Disabled Person), was extended to include a National Disability Awareness Campaign that would lead up to that specific day.

A national technical committee, comprising the various DPOs and government bodies, identified four themes to be implemented in four of the provinces:

Creative Arts and Education

- Economic Empowerment,
- Cultural Empowerment,
- Universal Access, and
- Education and Training

KwaZulu-Natal was chosen to be the site for implementing the National Cultural Empowerment Programme. The Department was chosen to spearhead this programme, and the Provincial Government contributed R50 000 towards the Campaign. Owing to a shortage of capacity, the South African Federal Council on Disability (SAFCD) was invited to partner us in implementing our objectives. R200 000 was transferred to the SAFCD to cover the running expenses.

Tshwaragano - In Touch Integrated Dance Project

The British Council approached the Department to fund this project. This was a national event that involved all the provinces. The week-long workshop was facilitated by Jill Waterman, and led by Adam Benjamin, the internationally acclaimed choreographer. Mr Benjamin worked with an integrated group of both able and disabled

(varying disabilities) bodies. This workshop included an in-school component, where participants, having worked with Mr Benjamin and his assistants, shared the knowledge and skills that they had acquired.

Workshops

A series of workshops, costing R50 000, were taken to schools and other public places such as libraries and shopping malls. Loren Kaplan from the Visual Arts and Crafts Academy (VACA) conducted visual arts and photographic workshops and facilitated other workshops that involved the MTN's Art Institute. MTN came on board with their Blind Alphabet Exhibition, and Gcina Mhlope was contracted to present story-telling workshops.

Music Festival

VSA (a disability in the arts organisation) ran an Adult Music Festival titled 'A Nite to Remember' on 18 November 2000. R12 000 was directed into this project to assist with performance rates of professional groups within the province. Although the age groups and disabilities varied, it did not include mental disabilities.



Creative Arts and Education

Story telling workshop, conducted by Gcina Mhlope.

Exhibitions

The Tatham Art Gallery organized the Bonnie Ntshalintshali Retrospective Exhibition on 16 November 2000. DACST contributed a sum of R10 000 towards this exhibition, which was opened by Benny Palime from the President's Office.

The launch of the Dan Rakgoathe Exhibition was facilitated by Carol Brown of the Durban Art Gallery on 20 November 2000. Donve Langhan's biography 'The Unfolding Man' was also launched. Rakgoathe's prints were made accessible to the blind through raised relief. The MTN's Braille Alphabet was also on exhibition. A major setback was the inaccessibility of the exhibition space for people in wheelchairs. This is a clear indication that old buildings or monuments need to be upgraded in terms of accessibility.

Mandla Mabila, Tommy Motswa and Elvis Ntombela's works were exhibited at the Bat Centre. All three artists in some way depicted the world through the eyes of a disabled person.



Dan Rakgoathe Exhibition: The Visual Arts made accessible to the blind through raised relief.

Creative Arts and Education

Women and Disability

A Focus on Women and Disability took place at the Bat Centre and comprised a poetry recital performed by three women who had written the poems. This was followed by a play called "Insignificant Others" performed by Anthea Carolus. The play dealt with issues on how the media influence the image of women and how women succumb to this negative image.

Theatre

The play called "Have you Heard?" performed by the NEA Communication House reverses the roles of hearing and deaf, such that it is abnormal to be

hearing in a deaf society. This short comedy was funded by DACST to go to the Deaf Drama Festival in Madrid shortly before our Campaign.

Dance

The Cape Town-based Remix Dance Project held an integrated wheelchair dancing workshop that resulted in a 15-minute dance piece that was included in the Gala Concert Programme.

Creative Arts and Education



A Celebration of Disability at the Gala Concert in Durban.

Debate

The Access-ability Debate was well received and there was much audience interaction especially from the deaf community. The way forward was seen to be more lobbying to ensure physical and social integration into society through accessibility to buildings, information and processes that determine the welfare of the disabled sector.

The Gala Concert - A Celebration of Ability

The gala concert was the crowning event that displayed the talents of the country's disabled artists from across the spectrum of our diverse cultures and provinces. The Playhouse, where the concert was held, had been made accessible for wheelchairs.

The Minister announced the introduction of the Disability Award. This will be awarded to proactive organizations that ensure accessibility for disabled people. The first award of R50 000 went to the South African Federal Council on Disability (SAFCD), and was received by Philip Thompson.

Creative Arts and Education

The Minister also announced that R5 million would be allocated to the NAC specifically for Disability Projects.

CREATIVE ARTS

Policy Development

In its policy development, the Subdirectorate focused on the requirements for developing cross-cultural programmes in as much as they involve awareness of each people's own way of life reflected in values, institutions and practices, i.e. technical facts vis-à-vis funda-

mental values. Policy development included planning, implementation, and monitoring, i.e. to develop cultural analysis through questioning assumptions, connections, and impact.

Description of Services

In the financial year 2000/2001 a number of programmes were supported to the amount of R650 000, in priority areas such as HIV/AIDS, the empowerment of women, youth stabilization and human resource development, and crime prevention.

Disability Programme: Art Workshop

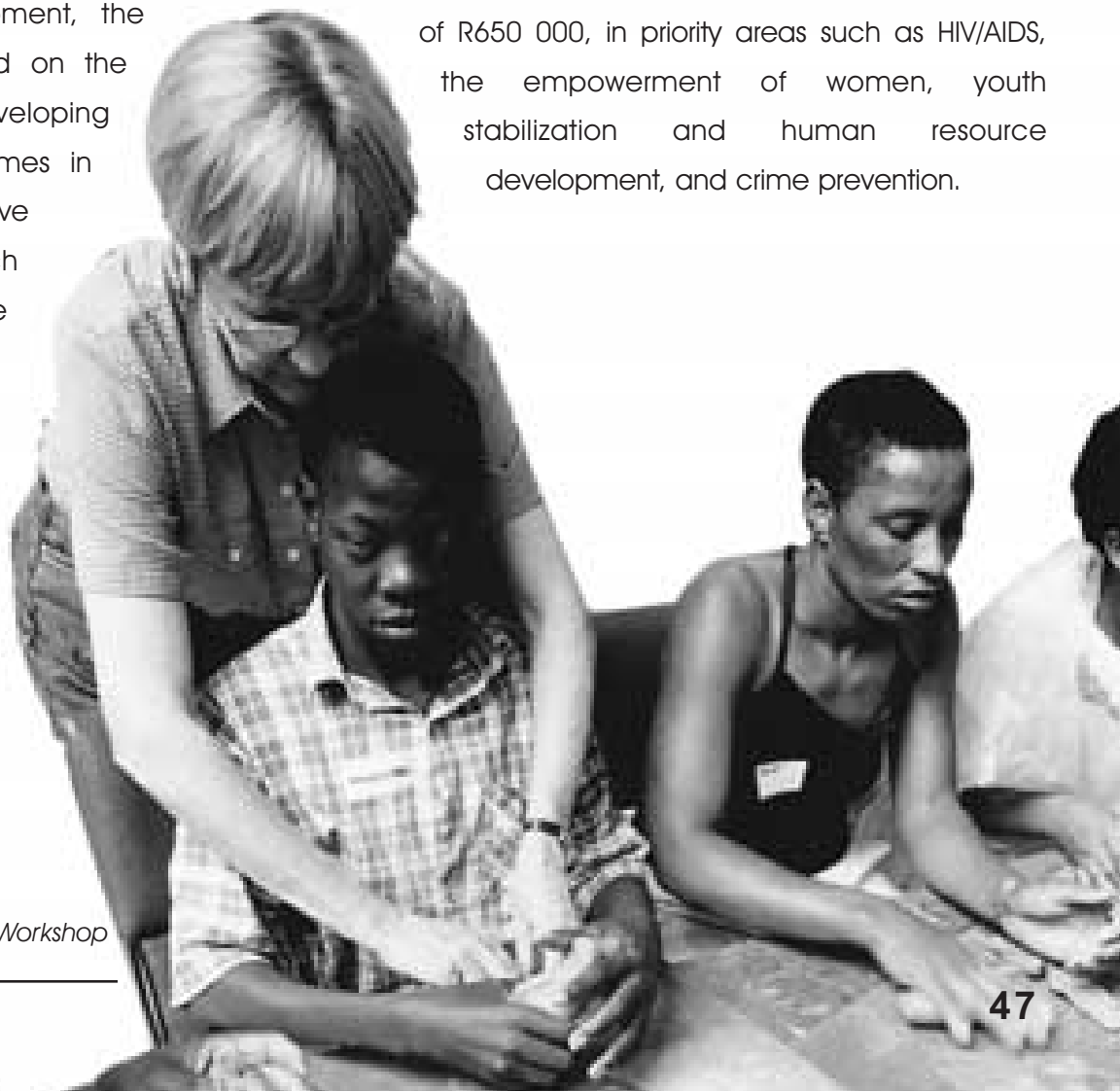



Creative Arts and Education

A disabled artist at the Gala Concert in Durban.

PRIORITY AREA	OBJECTIVES	PROGRAMME or PROJECT	DELIVERABLES	PERFORMANCE INDICATORS
	<ul style="list-style-type: none"> ■ To ensure equitable funding to arts practitioners at a national level ■ Policy Formulation 	National Arts Council	<ul style="list-style-type: none"> ■ Developing & supporting the arts ■ Reconstruction and development of the art form 	<ul style="list-style-type: none"> ■ Increase organizational capacity ■ Project development ■ Bursaries
	Facilitating & promoting partnerships between business and the arts	BASA	Job/wealth creation	<ul style="list-style-type: none"> ■ Matching grant funding ■ Establish synergy between business and the arts ■ Develop sustained business arts partnerships ■ Provide incentives to business to sponsor the project
Empowerment of women	To monitor cultural sensitivity and to determine the impact of the programmes in terms of gender roles relevant to development initiatives	(i) National Conference on Women in Writing	<ul style="list-style-type: none"> ■ Creating a forum for female & student writers. ■ To get a global view on the status of women in literature. ■ Participation in National Women's Day 	<ul style="list-style-type: none"> ■ Facilitating networking ■ Publication of presentations ■ Evaluating the involvement of rural women ■ Determine the feasibility to establish a women's publishing house
Crime Prevention and Criminal Diversion	<p>To plan and implement programmes that are sustainable because they are integrated in the recipient culture</p> <p>To use cultural opportunities for innovative and participatory programme facilitation, communication and advertisement</p>	(i) Stop Crime Drama Campaign	<ul style="list-style-type: none"> ■ To launch a successful festival with a strong anti-crime message ■ Utilizing new markets (venues) to attract new and bigger audiences ■ Reaching the community ■ Promoting criminal diversion through theatre 	<ul style="list-style-type: none"> ■ Stakeholders to buy in ■ Facilitate different levels of engagement to increase the impact of arts on the social fabric
HIV/AIDS Empowerment of Women Human Resource Development	To plan and implement programmes that are sustainable because they are integrated in the recipient culture	(i) XIII International Conference on Aids (ii) Satellite Conference Breaking the Silence (iii) Paper prayers (iv) Artists for Human Rights Billboards	<ul style="list-style-type: none"> ■ Women's Arts festival ■ People living with Aids ■ Story telling ■ Gender Forum Launch ■ Theatre Production ■ Workshops on the Play Process ■ Community Conference ■ Exhibition (R20 000) ■ Workshops ■ National Exposure 	<ul style="list-style-type: none"> ■ To determine the economic impact arts make in addressing social issues ■ Provide a platform for expression ■ Break the silent divides between participants and the population of KwaZulu-Natal ■ Provide edutainment ■ Networking

Creative Arts and Education

Youth stabilization	To promote, develop and implement programmes that are sustainable because they are integrated in the recipient culture	Abuy' Amathonga Project: Zulu Cultural Orchestra	<ul style="list-style-type: none"> ■ Ensure that all cultures occupy their rightful place in society ■ Promoting the objectives of the African Renaissance 	<ul style="list-style-type: none"> ■ Establish linkages and promote partnerships ■ Production of indigenous musical instruments ■ Highlight social problems through song, dance, poetry, story telling & entertainment ■ Launch of the orchestra
Human Resource Development Capacity Building	To predict cultural constraints in terms of programme implementation and to devise tools for identifying potential conflicts and for managing conflict	Performing Arts Management & Training Programme	To develop a strategy to enhance the performing arts managerial skills of various NGOs & art centres at a national level	<ul style="list-style-type: none"> ■ Needs analysis ■ Coordinating a training programme ■ Facilitating networking ■ Working groups ■ Monitoring & consolidation ■ Follow-up & projections for future developments
Urban Regeneration Human Resource Development	<ul style="list-style-type: none"> ■ To plan and implement programmes that are sustainable because they are integrated in the recipient culture ■ To open up new markets with innovative designs & products, thereby impacting on the economy ■ Restore community identity through design process ■ Economic, environmental and social regeneration of the community 	To recreate and uplift community identity by using design as a transformative tool to bring about healing & restoration	<p>Promoting the objectives of the African Renaissance</p> <p>Establish design as critical in addressing social issues</p>	Identify and establish partnerships to maximize programmes and facilities
Children at risk Stabilization of Youth Crime Prevention	To plan and implement programmes that are sustainable because they are integrated in the recipient culture	(i) Karos & Kambro (ii) Performing Art School for Children (iii) Youth Development Outreach	<ul style="list-style-type: none"> ■ Launching a pilot project with a view to national implementation with children at risk that would serve as a case study on the impact of theatre in bridging trauma and conveying life skills ■ Establishing a permanent facility for underprivileged youth while building opportunities to address low self-esteem and misdirected energy ■ To launch a pilot project for trial awaiting juveniles in which the performing arts are used as a medium to restore a sense of belonging within society 	<ul style="list-style-type: none"> ■ Evaluate the effect of the performing arts as a tool to prevent children at risk from turning to crime ■ Arts and culture development ■ Research & publications
Servicing Cultural Agreements	Exchange following a cultural Agreement	South Sea Jazz Festival	Promoting cultural exchange	A three-day jazz festival

Heritage

The Minister speaks at Women's Day Celebrations at the Union Buildings in Pretoria, 9 August 2000.



Heritage

PLANNING AND EVALUATION

Women's Monument

The Department initiated the development of the Women's Monument project to identify and construct a suitable commemorative structure to the 1956 women's anti-pass march to the Union Buildings. The Monument is a low structure that consists of an Imbokhodo (grinding stone), symbolizing the power of women, nestled in a bronzed plate on the vestibule between the east and west wings of the Union Buildings. Stairs that lead to the monument have been inscribed with gold lettering, reflecting an extract from the petition that was to be handed to Prime Minister J G Strydom.

The Women's Monument was unveiled at the Union Buildings by President TM Mbeki on 9 August 2000. The theme of the event was "Towards the 21st Century: Women in Action for Equality and a Better Life", and was attended by veterans of the 1956 anti-pass march. The Human Sciences Research Council (HSRC) produced a booklet highlighting prominent South African women who advanced the role of women in their respective fields.

Anglo-Boer South African War (ABSAW)

The Anglo-Boer War began on 11 October 1899 between Britain and two former republics, the Zuid-Afrikaansche Republic (Transvaal) and the Orange Free State.

Although the War has been portrayed as a conflict between Britain and the Boers, a large number of black South Africans residing in the two former republics were drastically affected by this War and died in large numbers. A national conference on the theme of black participation in the Anglo-Boer South African War was held in October 2000, attended by about 200 people. The role of the conference was to highlight the role black people played in the War.

The Khoi-San Project

Government initiated the Khoi-San project to acknowledge and promote the commemoration of the history and culture of Khoi-San peoples in South Africa. A workshop was held in December 2000 with representatives of Khoi-San communities and organizations to identify a suitable commemorative structure. The meeting decided to develop a national Khoi-San heritage route that

Heritage

will link historical, archaeological and culturally significant Khoi-San sites and objects.

Freedom Park Project

The Cabinet approved a portfolio of Legacy Projects that acknowledge and celebrate South Africa's multicultural heritage. Freedom Park has at its core the struggle for human rights and democracy in South Africa. It will represent, in a visible, experiential, and interactive manner, our developing national consciousness and identity. The Salvokop site in Pretoria has been approved

by Cabinet in May 2000 as the location for Freedom Park.

LIVING HERITAGE

Indigenous Music

In April 2000 Minister Ngubane appointed a panel of experts to advise on a national strategy for the collection, preservation, protection, development and promotion of South African indigenous music. The panel consulted with provinces and other stakeholders.

The consultative process culminated in a national conference in October 2000 where practitioners and representatives from other key national stakeholders such as the South African Music Rights Organisation (SAMRO), the Association of the



A serious-faced little girl at Women's Day Celebrations, 9 August 2000.

Heritage

South African Music Industry (ASAMI) and the Music Union of South Africa (MUSA), participated.

Minister Ngubane endorsed the draft strategy. A priority emanating from these recommendations is a research project to identify and collect indigenous music.

National Heritage Day, 24 September 2000

The Constitution recognizes 11 official languages for South Africa. The theme for National Heritage Day 2000 was "Celebrating Our Multilingualism" and the event was held at the Pietersburg Rugby Stadium in the Northern Province. As multilingualism is reflected in our variety of cultures, the day's activities consisted of a cultural programme with both local and cultural groups from other provinces performing, using all the South African languages. The National Sports Commission demonstrated two indigenous games: Marabaraba and Dibeke.

National Heritage Indaba

DACST introduced an integrated and interactive system for national heritage resource management through the establishment of the

South African Heritage Resource Agency (SAHRA), the Flagship Institutions (museums) and the South African Geographical Names Council.

Progress towards transformation of the heritage sector, through redress programmes and meaningful change within existing institutions has, however, been limited. DACST consequently held a National Heritage Indaba on 16 and 17 March 2001 that focused on the following key issues in the heritage sector: people, collections and exhibitions, networking, optimal utilization of existing resources, and attracting audiences. The findings of this Indaba are currently being developed into a corporate plan for the development and transformation of the sector over the next three to five years.

The President, Mr Thabo Mbeki, presents a speech at the Union Buildings. Women's Day, 9 August 2000.





Mr Vusithemba Ndima
Director: Heritage

Heritage

HERITAGE INSTITUTIONAL GOVERNANCE

The Subdirectorate: Institutional Governance administers 13 Declared Cultural Institutions (DCI). DCIs are cultural institutions that have been declared as such in terms of the Cultural Institutions Act, 1998. Each DCI is a corporate body and falls under the control,

management and direction of a council appointed by the Minister. Full annual reports are compiled by the institutions and are available from the institutions themselves. DACST subsidizes these institutions annually.

Subsidies paid over to the Declared Cultural Institutions:

DCI	SUBSIDY
Northern Flagship Institution*	R 22 026 000
Southern Flagship Institution*	R 24 263 000
National Museum, Bloemfontein	R 9 691 000
Natal Museum, Pietermaritzburg	R 4 909 000
William Humphreys Art Gallery, Kimberley	R 1 282 000
Afrikaans Language Museum and Language Monument, Paarl	R 1 034 000
National English Literary Museum, Grahamstown	R 1 887 000
National Zoological Gardens of South Africa, Pretoria	R 10 809 000
Engelenburg House Art Collection, Pretoria	R 84 000
War Museum of the Boer Republics, Bloemfontein	R 2 204 000
Voortrekker Museum, Pietermaritzburg	R 3 466 000
Robben Island Museum, Robben Island	R 21 238 000
Nelson Mandela Museum, Umtata	R 4 677 000

Heritage

South African Heritage Resources Agency

The South African Heritage Resources Agency (SAHRA) is a corporate body that is governed by a council appointed by the Minister. It has been established in terms of the National Heritage Resources Act, 1999. The object of SAHRA is to coordinate the identification and management of the national estate. SAHRA received a subsidy of R6 421 000 from DACST for the 2000/2001 financial year.

- To receive, investigate and recommend new geographical names and changes to existing names submitted by the PGNCs and other parties for approval by the Minister
- To liaise with national and international organizations, cultural, historical and linguistic organizations and the PGNCs
- To compile and publish official lists of approved names

GEOGRAPHICAL PLACE NAMES

Overview of the Council

The Minister of Arts, Culture, Science and Technology established the South African Geographical Names Council in terms of the South African Geographical Names Council Act, 1998.

Objectives

- To facilitate and set guidelines to establish a provincial geographical names committee (PGNC) in each province

Policy Documents

The following four policy documents have been approved by the Council:

- Business Plan
- Guidelines for the Establishment of Provincial Structures
- Guidelines for the Review of Existing Names

Heritage



The crowd at Women's Day, 2000, listens to the speech by President Thabo Mbeki.

Geographical Names recommended for approval

At each meeting the Council scrutinizes lists of names submitted for approval by the post office, local authorities, property developers and other interested parties. There are 142 names that have been approved by the Minister and published in the following Gazettes:

- Vol. 423, No. 21566 dated 22 September 2000; and

- Vol. 428, No. 22047 dated 16 February 2001.

Database

The Department is required to establish and implement a national database of approved geographical names in digital format to fulfil its brief to the Council.

Four existing databases were considered for use in order to compile a national database:

- The Place Names database of the Human

Heritage

Sciences Research Council (about 90 000 records of names);

- The National Place Names Committee database (about 5 000 records);
- The Chief Directorate of Surveys and Mapping database (91 600 names);
- The United States Board on Geographic Names Gazetteer of South Africa (about 120 000 names).

Review of Existing Names

The Council has commenced the review of names that have not previously been submitted for approval. Names that appear to have offensive and racist connotations have been referred to relevant authorities and communities for comment and suggested substitutes.

The draft fourth edition of the Toponymic Guidelines for South Africa, compiled by the United Nations Group of Experts on Geographical Names (UNGEGN), was submitted to the Council in May 2000. These guidelines cover the orthographies of the languages of South Africa and their application to geographical names. The Council

has made amendments to the draft, and it has been submitted to the National Language Bodies that have been established by the Pan South African Language Board, with the request that the orthographic rules should be brought into line with the most recent standardized orthographies.

Provincial Geographical Names Committees

The South African Geographical Names Council has been assigned the responsibility to facilitate the establishment of Provincial Geographical Names Committees (PGNC). At the meeting of the Minister and MECs Council (MINMEC) on 21 November 2000, the MECs agreed that the provincial structures should be set up as a matter of urgency. This process is expected to be completed by June 2001.

International Activities

• New York

In January 2000 the chairperson of the Council and a representative from the Department attended a two-week conference of UNGEGN in New York. South Africa was requested to convene a meeting of the Africa South Division and try to revive UNGEGN practices in those countries. The



Africa South Division is made up of the following countries: Zambia, Malawi, Zimbabwe, Mozambique, Angola, Namibia, Botswana, Lesotho, Swaziland and South Africa. This mandate has not yet been met as we are still grappling with our own transformation issues.

- **Korea**

The chairperson attended the 29th International Geographical Congress in Seoul, Korea, from 14 to 18 August 2000. The theme of the congress was "Living With Diversity". The subtheme in which the UNGEGN members were involved was titled Geography and Place Names. The chairperson's paper was entitled: "Eradicating Indigenous People's History and Heritage Through Naming: A South African Experience". This paper highlights geographical names that exist in other countries in the world which were enforced in our country at the expense of indigenous ones. Indigenous names had meaning in terms of history and heritage for the indigenous people of South Africa; therefore removing them means removing people's culture and heritage.

Heritage

OUTPUTS AND SERVICE DELIVERY TRENDS

Subprogrammes (Subdirectorates)	Outputs	Service delivery Indicators	Actual performance
Planning and Evaluation	Women's Monument Project	Monument is constructed	<ul style="list-style-type: none"> ● Monument is unveiled in August 2000
	Freedom Park	Monument will be constructed by 2004	<ul style="list-style-type: none"> ● Freedom Park Trustees appointed ● Salvokop Site approved by Cabinet in May 2000 ● Landwop initiated between DPW and Transnet
	Khoi-San Project	Suitable commemorative structure developed	<ul style="list-style-type: none"> ● Workshop and consultation with affected communities in December 2000 ● Heritage Trail identified as suitable commemorative project
	Anglo-Boer War/ South African War	Commemorate the War and highlight themes	<ul style="list-style-type: none"> ● Conference to highlight the role of black people participating in the War
Living Heritage	Promotion of indigenous music	Strategies in place for the protection; promotion and development of indigenous music	<ul style="list-style-type: none"> ● Appointed panel with mandate to devise a national strategy ● Conference hosted in October 2000 with stakeholders
	Promotion of Heritage Day	National Heritage Day celebrated	Heritage Day celebrated in the Northern Province under the theme "Celebrating Our Multilingualism"
	Promotion of African Renaissance	Promotion of Africa Week as a vehicle to promote indigenous music; dance and languages	Africa Week celebrated in September 2000
Transformation of the Heritage Sector	Effecting the transformation of the heritage sector	Transformation of museums & exhibitions in the Declared Cultural Institutions is ongoing and complies with international best practices	<ul style="list-style-type: none"> ● National Heritage Indaba hosted to promote issues of transformation; equity and redress
Institutional Governance	Administering the DCIs and ensuring effective sustainability of the DCI	DCIs are financially sustainability	<ul style="list-style-type: none"> ● Southern Flagship Institution undertakes institutional review of all museums under its management ● Appointed managers for the SFI and NFI ● Feasibility studies undertaken to develop the KwaZulu-Natal Flagship and the Bloemfontein/ Kimberley Flagship
Geographical Place Names	Ensuring standardization of place names	Ongoing restoration of proper geographical place names	<ul style="list-style-type: none"> ● Subcommittees established to streamline and support the work of the Council ● Establishment of consolidated database is being investigated ● 142 names approved and gazetted ● Two trips undertaken to ensure the SAGPNC is in line with international best practices

Arts and Culture International Liaison

*Traditional costumes at Kwaggafontein.
Freedom Day, 27 April 2000.*



Arts and Culture International Liaison

The key deliverables are servicing agreements, signing of new agreements, participation in exchange programmes and also to create opportunities for Human Resource Development. The Directorate is mandated to identify and compile a database of Overseas Development Assistance (ODA) and training and developmental opportunities for art and culture.

The Minister of Arts, Culture, Science and Technology accompanied the President during his visit to Cuba. Discussions included cooperation in the field of Arts, Culture, Science and Technology which culminated in the signing of an Arts and Culture Agreement in April 2001.

The Director-General of DACST, Dr R Adam, and his counterpart signed a Programme of Cooperation during the official visit of Minister B S Ngubane to India. The signed POC will be implemented in September/October 2001 by sending an Indian handicraft exhibition to South Africa.

Freedom Day Celebrations

In an attempt to market South African arts and culture overseas, the Department supported South African Embassies or Missions overseas to

celebrate Freedom Day. The following cultural groups represented South Africa:

Jamaica: Zamambo Cultural group conducted workshops in schools and shared expertise with the Jamaicans.

Venezuela: Two muralists, Mr Steven Maqashela and Ms Florence Nzimande, were invited to paint a mural depicting the history of murals and its usage in exposing the evils of apartheid in South Africa.

Hungary: Thula Sizwe Group conducted workshops in schools and also performed to raise funds for promotion of South African culture in Hungary.

Mauritius: In an attempt to sell South African jazz music the artist Jimmy Dlodlu was invited to Mauritius. Workshops were also conducted in an attempt to promote SA talent and experience.

Malawi: Exposing South African female artists falls within the objective of the International Liaison Directorate and that of the Department. The group Women Unite was identified to represent SA at the occasion.

Arts and Culture International Liaison



*Mr Victor Julius
Director: Arts and Culture
International Liaison*

Cultural Exchanges

Activities related to cultural exchanges with other countries stem from the content of our signed Programme of Cooperation and Arts and Culture Agreements.

- People's Republic of China - The Jiangzi Cultural Troupe visited four provinces in SA as part of the POC signed in 1999.

- Russian Federation - the content of the POC is being negotiated, as is as the establishment of cultural centres.
- People's Republic of China - South Africa was invited to present a paper on the "Preservation and promotion of national culture in the developing face of the movement towards political and economic integration".
- Mexico - POC that will focus mainly on training and development of expertise was signed in April 2001.
- Malawi - The group Candy N'wayingwani was identified and participated in the exchange programme.

PROJECTS WITHIN AFRICA

In pursuance of the objectives of the African Renaissance and the Millennium African Programme, the Department participated in a number of events and activities:

Arts and Culture International Liaison

Ma-Afrika

Ma-Afrika is an annual competition for the people of Africa, specifically women, organized by the Benoni Publicity Association (BPA). The aim of the competition is to recognize and reward the efforts of dedicated women in Africa. The Department has decided to associate itself with the international part of the project within the scope of the African Renaissance programme of action. DACST has contributed advisory and financial support for the project since 1999.

SADC Inter-Ministerial Conference on Culture

DACST coordinated South Africa's participation in the Conference. The Conference was funded by cooperating partners, namely the Swedish International Development Agency (SIDA), the Ford

Foundation, World Intellectual Property Organization (WIPO) and Norwegian Agency for Development Cooperation (NORAD). South Africa was represented by delegates from the following institutions: The Pan South African Language Board (PANSALB), Market Theatre Foundation, National Film and Video Foundation (NFVF), South African Museums Association (SAMA) and DACST. During the deliberations of the Conference, it was recommended that a SADC Culture Trust Fund be established.

Arts and Culture International Liaison



Bright colours at Kwaggafontein. Freedom Day Celebrations, 27 April, 2000.

Tenth Session of SADC Ministers of Culture, Information and Sport, Mauritius

The tenth session of the meeting was hosted by Mauritius during April and May 2001.

The second meeting, which was scheduled for 28 to 30 May 2000 in Mauritius was attended by officials from DACST and Dr Devan Pillay from GCIS.

Africa Day Celebrations, 25 May 2000

The commemoration of Africa Day is marked by a celebratory reception hosted by the Department of Foreign Affairs (DFA) and DACST, being responsible for the Cultural

Manifestation Programme. This function was hosted at the Presidential Guest House and was attended by African diplomats, business leaders, government officials and Ministers.

The Department's prime responsibility is to involve and feature more sectors such as NGOs, research institutes and provincial departments of Arts and Culture in the celebrations.

JOINT BINATIONAL COMMISSIONS

The Third Session of the SA-Tunisia Binational Commission was held in Tunis, Tunisia, from 1 to 3 April 2001. The JBC was coordinated by

Arts and Culture International Liaison

the Department of Foreign Affairs and the SA delegation was led by Minister Nkosazana Dlamini-Zuma. During meetings with their counterparts, the delegation discussed possible areas of cooperation in the fields of arts, culture, science and technology.

The Third Session of the SA-Nigeria Binational Commission (BNC)

The Third Session of the South Africa Nigeria Binational Commission was held in Abuja, Nigeria, from 6 to 12 March 2001. The BNC was coordinated by the Department of Foreign Affairs. The DACST delegation was led by Deputy Minister Bridgette Mabandla. The cultural agreement on arts and culture signed by the Deputy President focused on archives, institutional exchange, restoration of monuments and historic sites, performing arts and linguistic diversity.

ARTS INSTITUTIONAL GOVERNANCE

Establishment

The Directorate: Arts Institutional Governance oversees all nine arts institutions associated with the Department. These institutions are the State

Theatre, the Playhouse, ArtsCape, Pacof's, the Market Theatre, Windybrow Centre for the Arts, the National Arts Council, Business and Arts South Africa and the National Film and Video Foundation. This Directorate was specifically established by the Department to ensure that there is proper transformation, in line with government objectives, and that the arts institutions remain accountable for public funds. The institutions have been established by the Department as agents for transformation, promotion and development of the arts. They also have an added responsibility of distributing governmental funding for the arts, marketing the country internationally and creating access for opportunities in the arts for all South African communities.



Arts and Culture International Liaison



Traditional dances at Kwaggafontein. Freedom Day, 27 April 2000.

Legislation administered

- Cultural Institutions Act (House of Assembly), 1989
- Cultural Institutions Act, 1969
- Culture Promotion Act, 1989
- National Arts Council Act, 1997
- National Film and Video Foundation Act, 1997

Policy developments

National plan for the Performing Arts in South Africa

Prior to 1994, government resources for the arts were channelled to Performing Arts Councils (PACs), while other practitioners were left to fend for themselves. In addressing these cultural imbalances the democratic government engaged in comprehensive consultative and research processes that began with the Arts and Culture Task Group

Arts and Culture International Liaison

(ACTAG) and resulted in the White Paper for Arts, Culture and Heritage. The White Paper spells out the process of downsizing of funding to the PACs with emphasis on their transformation into playhouses. The implication of the playhouse concept is that theatres will make their infrastructures accessible to arts practitioners. The government will subsidize the core infrastructure, core staff and essential activities of the PACs.

The essence of the performing arts policy is to ensure that these transformation imperatives are achieved and remain sustainable. The Department is currently consulting stakeholders in the new plan to ensure that inputs are solicited to finalize the policy.

Delivery

- Implementation of the White Paper on PACs

During July 2000 the Minister appointed the National Advisory Board to advise on the

implementation of the National Policy for the Performing Arts and devise a plan for the reopening of the State Theatre. In addition, the Committee was tasked to develop an implementation strategy for the national plan for the performing arts. The strategy has been completed and the process of consultation with stakeholders has begun.

- Business Plan and reopening of the State Theatre

A new business plan that positions the State Theatre as a playhouse has been drafted. This and other positive developments paved the way for its reopening on the 4 April 2001. This will represent a new beginning for the performing arts in South Africa.

- National Arts Council new funding criteria

The National Arts Council developed new funding criteria which positioned it as a structure that funds projects of national significance. Workshops to explain and clarify the criteria were held in all nine provinces.

National Archives



State Archives, Hamilton Street, Pretoria. An official supplying documents to the reading room.

National Archives

Policy

In 2000 steady progress was made with the practical implementation and legal interpretation of the legislative framework within which South Africa's transformed public archives system is being developed. The National Archives of South Africa Act, 1996, and the National Archives Regulations provide the statutory framework for this process.

Other interlinking pieces of legislation operate together with the Act to delineate and define the country's public archives system. During 2000 legislation relating to legal deposit, national heritage and open democracy was promulgated. The National Archives participated in their drafting processes in the report year 1999, most notably in the Promotion of Access to Information Act, 2000. In addition, all provinces were assisted with the drafting of their own archival legislation, as determined in Schedule 5 of the Constitution. Only the Free State and Mpumalanga have passed their own legislation.

The National Film, Video and Sound Archives were instrumental in the process of refining the Legal Deposit Act and the Regulations for the Act. The

Head has been appointed to serve on the Legal Deposit Committee of South Africa.

National Archives Commission

In this report year problems were encountered with regard to the functions of this body and allocation of resources. Amendments to the relevant legislation are being prepared to resolve the issues.

Services and projects

Repositories and record centres

Public records with enduring value are preserved in repositories and record centres in six different cities throughout South Africa. As was reported in 1999 severe budgetary restraints have resulted in most of the facilities experiencing an acute shortage of space. Additionally, they lack equipment essential to executing some aspects of their mandatory services to government and the public. A case in point was the Johannesburg Records Centre, which could not be sustained. Hence between April and December 2000 the records that were housed there were systematically transferred to the National Archives and the Records Centre was closed.

National Archives

State Archives, Hamilton Street, Pretoria. An official receives an archives group from a client office.

It was reported in 1999 that a proposal for a major expansion of the National Archives Repository, Pretoria, was under consideration. Correspondence in this regard was exchanged between the Directors-General of the two Departments concerned. Funds for the construction have been requested for 2001/2002. In the previous report year a proposal for the re-equipping of the National Film, Video and Sound Archives was approved. Work is in progress.

Transfer of public records

The National Archives are experiencing difficulties with managing a controlled, systematic transfer of public records into archival custody for the reasons mentioned above. Many transfers have had to be deferred because of space problems.

National Oral History Programme

The National Archives of South Africa Act

requires the National Archives to emphasize in their collecting activities the acquisition of such non-public records as would fill gaps in their holdings of public records. The National Archives have embarked on various oral history projects to ensure that orality, as a cultural tradition and heritage resource, is not lost. In 2000 the National Oral History Programme, spearheaded by the Department and coordinated by the National Archives, was launched. This was the culmination of the pilot oral history project reported on in 1999.

Outreach Programmes

There are still considerable barriers to access of records, caused historically by the apartheid system. Hence the Act obliges the National Archives to find ways of addressing this problem by emphasizing corrective endeavours aimed at reaching out to less privileged members of society. All repositories

National Archives

that make up the National Archives embarked on numerous outreach programmes in the year 2000. These included extended opening hours to accommodate working people, group visits, exhibitions, lectures at tertiary institutions, presentation of conference papers, workshops, media interviews, joint projects with other organizations, the staging of open days to coincide with national public holidays and the running of shows of audio-visual material (film and video).

Archives Educational Kit

The National Archives designed an archives educational kit that serves to introduce the high school student to the National Archives. During 2000 this educational kit was given a pilot run in very diverse schools in two provinces. It is currently a joint project with the Department of Education. It is envisaged that the kit will be launched by the end of 2001.

National automated registers

The Act requires the National Archives to maintain national automated registers. In 2000 eight new guides to the national registers, four gravestone

guides and nine lists of books were finalized. These publications improve the reference services and the retrieval of records.

NAAIRS

In 2000 a considerable amount of work was done to produce an archives web site in order to expand and refine the retrieval system nationally as well as to make the national public archives service known and encourage the growth of its clientele. The web site will serve as the portal for access to the National Automated Archival Information Retrieval System (NAAIRS). NAAIRS was web-enabled in a major project in March 2001. It is envisaged that the web site will be officially launched at the beginning of the next report year.

Guidelines for the Management of Electronic Records in Governmental Bodies

In terms of the Act, the National Archives play a vital role in regulating current record-keeping of government. The interventions to promote sound records management have a number of objectives. Firstly, to ensure efficient administration and service delivery. Secondly, transparency and accountability, and to comply with the Promotion



*Dr Graham Dominy
Chief Director:
National Archives*

National Archives

of Access to Information Act, 2000. And thirdly, they seek to ensure that archival records are identified and preserved for posterity. The National Archives have taken proactive steps to accommodate the changing nature of record-keeping in the electronic environment and have produced Guidelines for the Management of Electronic Records in Governmental Bodies. Ties were forged with the State Information Technology Agency (SITA) to work towards establishing standards for electronic records systems used in government. Available resources are however inadequate to match the actual need for records management services, particularly in the light of the loss of records

State Archives, Hamilton Street, Pretoria. An official, Miss A Simelane looks at a map in the map strongroom.

management expertise within the public service. Therefore the National Archives have given special attention to the training of records managers and registry clerks, and to the revision of directives and guidelines, such as the Archives Instructions. This material was also placed on the National Archives' web site.

Provincialization

The problems experienced in effecting the constitutional mandate for the provincialization of archives are of major concern. The National Archives lack the capacity to implement effective records management at provincial and local levels. Capacity-building for provinces is therefore essential.

International liaison

The National Archives have continued to play an active role in the international archival community since their readmission to the International Council on Archives (ICA) in 1993. A special focus has been placed on a consistent interaction, particularly with the

Department of Arts, Culture, Science and Technology



National Archives

Eastern and Southern African archives community (ESARBICA). Active membership of the ICA and other international bodies has been maintained.

Members of staff attended professional gatherings in Germany, Australia, Spain, Poland, Norway, the United States and Tanzania. Professionals from Swaziland, Malawi, Botswana, China, the United Kingdom and the United States of America visited South Africa. At the end of March 2001 the new National Archivist headed a DACST delegation on the binational commission to Tunisia.

Other international activities of the National Archives were:

- Participation in a joint South Africa-US Partnership Programme designed to support heritage endeavours in South Africa
- Providing professional archival training (internships) to staff from archives in the eastern and southern Africa region, for example from Botswana.

Flagship projects

Project 1: Expanding the services of records management in support of the operations of the Truth and Reconciliation Commission

In 2000 the National Archives continued to advise



and assist the Truth and Reconciliation Commission (TRC) with its final stages of the amnesty process. This was achieved in a number of ways: the facilitation of research, interrepository transfer of public records for the convenience of the TRC, and technical advice and assistance to the support staff of the TRC. In this report year records management support services to the TRC were extended, with National Archives staff spending protracted periods of time at the Cape Town offices of the TRC in order to assist with its records management programme, as well as with various aspects of the preparation and processing of a TRC archive. Finally, a task team spent time in Cape Town to plan the transfer of the TRC records to the National Archives.

National Archives

Project 2: Training in functional literacy for cleaning and ground staff

In 2000 a project was undertaken for the first time to include cleaning staff and ground workers in formal training endeavours that correlate with the operational goals of the organisation. From February to October 2000 15 learners participated in an Adult Basic Education and Training programme (ABET). The course articulates with the National Qualifications Framework (NQF) and was highly successful. Thirteen of the 15 candidates who sat for the examination passed and eight of the previously non-literate candidates had either articles or letters published in the internal staff journal of the National Archives, Archives News.

General

On 30 September 2000 the National Archivist had to retire due to ill-health. She had held the post of Director. On 1 March 2001 a new National Archivist assumed duty at the level of Chief Director. A new head of the National Film, Video and Sound Archives was appointed at the level of Deputy Director on 1 December 2000.

THE BUREAU OF HERALDRY

The Bureau of Heraldry is responsible for the registration of coats of arms, badges and other emblems such as flags, seals, medals and insignia of rank, office or order, and the names and uniforms (colours) of associations and institutions such as universities, schools and clubs, and for advising on heraldic and related matters.

The Bureau maintains a high standard of heraldic design and finished artwork and is regarded as one of the world's leading exponents of heraldic design.

The distinctive South African heraldic idiom incorporates many symbols from our culturally diverse society and has become a hallmark for international heraldic development.

During 2000 the Bureau responded to a constant stream of enquiries about heraldic, flag and genealogical matters from both within South Africa and from abroad.

Policy

The Heraldry Council formulates the Bureau's

National Archives

policy. From the ranks of the Heraldry Council, a Heraldry Committee is appointed which decides on matters referred to it by the State Herald. It considers objections to applications for registration, for example. The question of graphic national symbols is an integral part of the brief of the Heraldry Council.

During the year 2000, the Heraldry Council met twice. At the first of these meetings, the Council formulated its comments on proposals for a new national coat of arms, for consideration by Cabinet.

Research

The year 2000 saw ongoing research to foster the development of a distinctive South African heraldic idiom. The political changes from apartheid to democracy have impacted on heraldic requirements. A focus of research is therefore to address these changing requirements, with continued research being conducted into South African honours and awards as well as indigenous symbols and symbolism. The focus has been broadened to accommodate ethnic art, design and symbolism.

Flagship project

In January 1999 Cabinet decided that a new national coat of arms should be introduced with effect from 1 January 2000. For a number of reasons this process took longer than originally anticipated, and the new national coat of arms was introduced on 27 April 2000. The Government Communications and Information System (GCIS) is responsible for the process of implementation of the new national coat of arms.

International liaison

Regular contact is maintained with heraldic, flag and related authorities in the international heraldic community. Hence the provision of advice on heraldic and related matters to overseas bodies is an integral part of the Bureau's work. The Assistant State Herald attended an international congress in France, where he delivered a paper on the new provincial and national coats of arms.

General

During the report year the State Herald retired, but was requested to continue in that capacity on a part-time basis until a successor is appointed.



*Dr Nonhlanhla Mkhulisi
Director: National Language Service*

National Language Service

LANGUAGE PLANNING

The primary objectives of the Language Planning Subdirectorates are to promote multilingualism and advise government on the development and implementation of language policy.

Policy developments

Language Policy and Plan for South Africa and the South African Languages Draft Bill

The main objective of a Language Policy and Plan for South Africa is to facilitate individual and national empowerment by promoting the use of all the official languages to ensure that South Africans have the freedom of using the official language of their choice.

The Minister appointed an advisory panel to prepare a final draft of the Language Policy and Plan for South Africa which was presented, with its concomitant draft Bill, to stakeholders at the Second Language Indaba in Durban in March 2000. After incorporating their comments, the Language Policy and Plan for South Africa was presented to the

Cabinet Committee for the Social Sector on 13 September 2000. The Committee recommended that a further discussion document on the matter be submitted, taking into account the priorities of the country and broad financial implications.

Following these recommendations a comprehensive survey was conducted in national government departments and the provinces to determine the status of available language infrastructure. A cost estimate of the proposed policy is being done in collaboration with the National Treasury. A revised document will be submitted to Cabinet in September 2001.

SA Language Practitioners' Council Draft Bill

In response to the Language Policy and Plan the South African Language Practitioners' Council Draft Bill was prepared in collaboration with the Pan South African Language Board (PANSALB) and debated at the Second Language Indaba in March 2000. The main objective of the proposed Bill is to establish a body that will regulate the language facilitation profession by managing

National Language Service

the accreditation and registration of language workers such as translators, editors, interpreters and terminologists.

Human Language Technologies

The field of Human Language Technologies (HLT) relates to the design and use of tools for specific human computer interaction and offers solutions to problems arising from those activities. The Subdirectorate developed a strategic plan on HLT for South Africa in collaboration with PANSALB and HLT experts. A draft document, "The Development of Human Language Technologies in South Africa: Strategic Planning", was prepared which argues the case for a dedicated policy in respect of HLT.

Study tour to the European Union

Following a request by a Parliamentary interest group on language policy, representatives of the NLS, members of the Minister's Advisory Panel on Language Policy, and members of PANSALB paid a visit to the European Union (EU) in March 2001 to attend a conference with EU representatives in Brussels on the management of multilingualism in the EU. In view of the imminent finalization of the Language Policy and Plan for South Africa an

important aim of the visit was to study the applicability to South African circumstances of the manner in which the EU manages multilingualism and in particular how practical concerns such as the cost of multilingualism are addressed.

Language awareness

The Subdirectorate was involved in the organisation of the Heritage Day 2000 celebrations on 24 September. The theme of Heritage Day 2000 was "Celebrating our multilingualism" and the national event was held in the Northern Province, which is home to some of the most marginalized indigenous languages of South Africa, e.g. Tshivenda and Xitsonga. Our linguistic diversity was celebrated with performances by various cultural and language groups and the presentation of the PANSALB awards to acclaimed writers writing in the indigenous languages.

Support of a multilingual booklet

The Subdirectorate collaborated with the Unit for Language Facilitation and Empowerment of the University of the Free State in producing a booklet on social security issues in all the official



Language Indaba, 2000.

languages. Some 500 complimentary copies of the booklet in each official language were distributed at the Heritage Day 2000 celebrations in Pietersburg.

Spellcheckers for African languages

The Subdirectorates commissioned a process to develop spellcheckers for the ten official indigenous languages in collaboration with an expert in corpus linguistics.

UNESCO World Languages Report

The Subdirectorates commissioned a groundbreaking survey to gather information on all the official languages as well as the Khoe, San and Nama languages of South Africa for the UNESCO World Languages Report which will be published in 2001. The aim of the UNESCO World Languages Report is to describe the linguistic diversity of the world and to establish proper management of the world's linguistic heritage.

The survey addresses a wide variety of aspects regarding the languages used in South Africa, such as geographical

National Language Service

information, varieties and number of speakers of each language, economic activity of speech communities and literacy traditions. This information has been included in the Subdirectorates' database on South African language matters.

Database on South African language matters

The Subdirectorates maintained and updated a comprehensive database on language matters in South Africa. It includes a list of language and language-related legislation in South Africa, translation and interpreting services/bureaux, freelance language workers and translator training institutions, language interest groups, stakeholders and language committees.

TERMINOLOGY COORDINATION

The Terminology Subdirectorates' main objective is to coordinate the production of terminologies and external terminological contributions, forge partnerships with collaborators and stakeholders and disseminate term lists to users, clients and collaborators.

National Language Service

Terminology projects include

School projects

A primary focus in the Subdirectorates is documenting and developing terminologies for the learning areas of Mathematics, Science and Technology to serve as supportive aids in education, whereby the learners' conceptualization and the teachers' actions of transporting knowledge to learners could be facilitated.

- Mathematics

This project is focused on terms used in the foundation phase of education. Approximately 1 500 terms have been excerpted and documented.

- Science

This project is focused on terms used in the intermediate learning phase. Approximately 2 000 terms have been identified, excerpted, defined and documented in a low register to encourage and promote mother tongue education for all South African learners.

- Geography

Approximately 2 200 terms have been documented for this project at the intermediate education levels of grades 4 to 6. Core terminology has been defined.

These endeavours should benefit both learners and teachers.

Multilingual Building Dictionary

Attention was given to the subfields of Industrial Safety, Site Preparation and Management, Building Bye-laws and Labour Relations, Natural Stone Construction, Concrete Technology and innovational construction practices, which resulted in more than 13 000 terms with numerous definitions and explanatory notes.

Terminology for Human Resource Management

Transformation in the public service in the field of human resource management is generating many new terms. This database contains more than 2 000 entry terms with enriched terminological information such as context, definitions, and example sentences. Equivalents in

National Language Service

certain target languages have also been added for some of the term records.

Dietetics Dictionary

The bilingual terminological data have been finalized. The additional introductory dictionary components forming the front matter of the dictionary were also completed. Means are currently being investigated to give users electronic access to the information in the database.

Dictionary of Statistics

Having reached international status, the terminology is still being developed and updated, in particular through the addition of African language equivalents and definitions.

Physics Dictionary

The dictionary has now been completed and the terminology content has been transferred to the MultiTerm terminology management software program. Appendices containing the correct usage and form of symbols used in Physics and Astronomy, as well as

metric and Standard International units are being finalized.

Dictionary of Political and Related Science

The database content is in the final editing stage.

Collaboration and Liaison

Cooperation and liaison with all bodies, including PANSALB, tertiary institutions and provincial language services, is a priority. Collective terminology development is of great importance for optimizing service delivery and accelerating the expansion of the National Termbank. The Subdirectorates participated in the monthly activities of the African Languages Terminology Initiative (ALTI) under the auspices of the Greater Johannesburg Metropolitan Council, and in the project on Legal Terminology in African Languages under the auspices of the Centre for Legal Terminology in African Languages.

Part of the Subdirectorates' collaboration activities lead to its hosting of two terminology workshops in March 2000, namely:

National Language Service

- **Workshop on road safety terms** in which the Department of Transport collaborated. Expert officials from the traffic departments of local governments played an important role in providing explanations of traffic signs and road safety concepts.
- **Workshop on parliamentary terminology** Translators from the national Hansard office and the provincial language offices were given the opportunity to discuss the exact meaning of terms with subject specialists, and to decide on acceptable equivalents.

Audit of terminology projects in South Africa

In June and July 2000 the Subdirectorate conducted an audit of terminology projects in South Africa with a view to coordinating and facilitating terminology projects and ensuring the documentation and dissemination of standardized multilingual terminologies. It is envisaged that terminology created by various bodies will be captured in the National Termbank of the NLS.

Participation in the 5th TermNet symposium: "TAMA 2001"

An assistant director attended the 5th TermNet symposium "TAMA 2001" (Terminology in Advanced Mobile Computing Applications) in Antwerp, Belgium, in February 2001. The aim of the TAMA 2001 symposium was to facilitate international sharing of terminological knowledge with a multilingual content and the interoperability in multimedia and cross-media environments.

TRANSLATION AND EDITING

The aim of the Subdirectorate is to provide a translation and editing service in the 11 official languages and foreign languages to national government departments.

African Languages Section

A variety of documents were submitted by government departments, statutory bodies and also provincial departments for translation: notices, letters, questionnaires, advertisements, brochures, legislation, white papers, green papers and general documents.

National Language Service

TABLE 1: Number of documents translated in-house and outsourced by African Languages Section

Language	Documents outsourced	In-house translations	Total
Setswana	21	76	97
Sepedi	30	81	111
IsiNdebele	13	74	87
siSwati	25	66	91
Xitsonga	35	67	102
Tshivenda	33	93	126
Sesotho	77	80	157
IsiXhosa	176	15	191
IsiZulu	67	113	180
TOTAL	477	665	1 142

National Language Service

English/Afrikaans Section

As in the past the Section dealt with documents across a broad spectrum of subjects, ranging from legislation to information pamphlets. This diversity is reflected by the following examples of work done this year:

- Natural Scientific Professions Bill
- National Forest and Fire Laws Amendment Bill
- Regulations on circumcision in the Eastern Cape
- Regulations on major hazardous installations
- South Africa Yearbook 2000/01
- Discussion document on traditional leaders and institutions
- Strategic plan for the National Film, Video and Sound Archives
- Administration manual for conducting bilateral international scientific and technological cooperation

National Language Service

TABLE 2: Number of pages translated and edited in-house and outsourced by English/Afrikaans Section

Language	No. of pages in-house		No. of pages outsourced		Total
	Translation	Editing	Translation	Editing	
Afrikaans	1 384,57	1 586,46	548,72	223,52	3 743,27
English	1 355,84	3 377,05	330,19	1 877,98	6 941,06
TOTAL	2 740,41	4 963,51	878,91	2 101,50	10 684,33

Language examinations

The Section was also responsible for conducting language examinations for the NLS. A total of 63 examinations for the selection of language practitioners at

all levels were conducted. In addition to internal requirements, this service was also provided to the South African Police Service, the Free State Province and the National Defence Force.

National Language Service

Clients

The Section provided its services to virtually all national departments. The Department of Labour was again the Section's biggest client, closely followed by DACST. Work done for Labour included bargaining council agreements, regulations, and the annual reports of the Department, the Compensation Fund and the Unemployment Fund. Other departments that made regular use of the Section's services included Justice, Health, Trade and Industry, and Welfare. Work was also done for the Government Communication and Information Service, Statistics South Africa and the Council for Geoscience.

Foreign Languages Section

A total number of 2 462 documents were received for translation and/or editing during the period under review, of which 1 926 were dealt with in-house and 536 outsourced. These included translations from and into major European languages (French, Spanish, Portuguese, German), and translations from Eastern European languages (Polish, Russian, Romanian, Czech, Serbo-Croat), Nordic languages (Danish and Lithuanian), languages from the Middle East (Arabic, Hebrew,

Farsi), the Far East (Japanese, Chinese, Thai, Korean) and elsewhere in Africa (Swahili, Somali, Lingala).

Documents in French continued to top the list. Its representation grew from 47% in 1999 to 65,8% for the corresponding period January to December in 2000. Spanish also showed a sharp increase. Ranked 4th in 1999 (8,4%) it rose to 2nd place (22,6%) in 2000.

Types of documents

The Foreign Languages Section received on a regular basis reports, dispatch letters, general correspondence, bilateral agreements, legislation, articles, questionnaires, records of court proceedings, and requests for extradition and/or international police/judicial assistance. The large number of agreements submitted is an indication of South Africa's growing international relations. Bilateral agreements were received in the fields of taxation, health matters, maritime matters, aviation, police matters, trade as well as animal and plant health in languages including Lithuanian, Spanish, French, Chinese, Arabic and Farsi.



*Dr Tau-Mzamane
Deputy Director-General
Science and Technology*

Foresight Launch, 23 March, 2000. Theatrical Performance by the Victory Songqoba Theatre Company.



The Science and Technology Branch of the Department strives towards introducing measures that put science and technology to work to make an impact on growth and development in a sustainable manner, in areas that matter to all the people of South Africa.

This includes focused interventions, networking and acting as a catalyst for change in terms of both the productive components of our economy, making it competitive in a globally liberalized environment, and also in respect of the huge development backlog existing among the poorest components of our society. The goal of realizing this vision is underpinned by development and resourcing strategies for the formation of science, engineering and technology human capital, democratization of state and society, promotion of an information society and ensuring environmental sustainability in development programmes.

Strategic Direction

Maintaining an adequate science base and translating it into jobs and growth poses some major challenges. The approach of National System of Innovation (NSI) in recognizing the non-

linearity of innovation - where performance is a function not only of the innovation in individual organizations but also of the relationships and networks between institutions - is increasingly driving government towards the **role of catalyst, facilitator and strategic investor**.

It is against this backdrop that the Branch set out in November 2000 to review the performance and strategic vision of each of the directorates that currently exist within the Branch to meet the objectives outlined below. The role that the Branch is currently perceived to be playing by all Branch staff was critically examined, particularly to identify whether it was regarded as "passenger or driver" in respect of the NSI. It was an exercise that was well worth the time spent. It served to affirm the effectiveness of the work that is happening, the areas where directorates can do better as well as gaps where new and different capacities are needed to meet the growing responsibilities of the Department in respect of the broader national development agenda.

Science and Technology



*Ms Marjorie Pyoos,
Chief Director: Research and
Technology Development*

Branch objectives

- Maximizing the contribution of Science, Engineering and Technology (SET) institutions to the achievement of the goals encompassed by the adoption of a National System of Innovation strategy for development.
- Promoting public awareness, appreciation, critical evaluation and understanding of SET through systemic, coherent and coordinated projects.
- Strengthening the extent and nature of private sector articulation within the NSI.
- Managing the establishment of new institutional infrastructure where such ventures demonstrate potential for impacting positively on development at a sectoral or macro level.
- Improving and strengthening the level of collaboration within the broader research community.
- Promoting engagement by South Africa's research community with strategic partners/collaborators within the international science and technology community.
- Internationalizing/branding South Africa's SET capabilities
- Improving the quality and depth of SET statistical information to support development and investment decision making as well as to drive improvements in the quality of SET activities against the backdrop of internationally recognized benchmarks.
- Promoting access to and utilisation of information as a strategic resource.
- Advancing information literacy to facilitate science literacy.

Science and Technology

SYSTEMS, EVALUATION AND RESOURCING

The activities of the Directorate are shaped by the goals of the National System of Innovation (NSI) of improving South Africa's competitive position in a globalized economy and an improved quality of life for all South Africans. These goals are underpinned by development and resourcing strategies for human resource development, promotion of an information society and development of institutional platforms for achieving the NSI's goals. Some of the more important activities that the Directorate engaged in during the period under review included:

- Management of the Science Vote process (distribution of parliamentary grant funding across the Science and Technology base of South Africa);
- Management of the Innovation Fund;
- Introduction of an Equipment Placement Programme for science councils;
- Activities designed to raise the level of debate around the statistical measurement of science,

engineering and technology performance (particularly in the developing country context).

■ The Science Vote

This amounts to R1,5 billion of parliamentary grant funding for disbursement to institutions such as the CSIR, the SABS, the Agricultural Research Council, Mintek, the Council for Medical Research, the HSRC, the National Research Foundation, the Council for Geoscience, the Africa Institute and the Innovation Fund. The strategy introduced by the White Paper on Science and Technology and driven hard since 1999 has seen a decisive 8% shift of the funding away from the core operations of the science councils into a competitive framework, the Innovation Fund. This programme has as its primary objective the harnessing of research and technology development capacity for addressing major problems/challenges that require a multidisciplinary research effort and the security of a medium-term financial commitment.

Other critical shifts are reflected in the rate of increase in the resources directed to the National Research Foundation (NRF), a statutory body mandated to develop research capacity

Science and Technology

primarily within the higher education sector. The NRF was also provided with resources (mobility grant funding) to enable researchers within the higher education sector to access equipment and infrastructure at the National Laser Centre, a new institution set up by DACST during the year 2000 to drive technology development in the laser field.

Also on a high growth path is the Medical Research Council (MRC). With an acknowledged underfunding in medical and health systems research the MRC received a 36% increase in its budget for the period

under review. It is expected that by 2003/2004 it will have trebled from the 1999/2000 funding base. Included in the support are ring-fenced funds for a research programme in HIV/Aids vaccines.

■ The Innovation Fund

Following the adoption of the White Paper on Science and Technology, with its identification of the need for government to support the National System of Innovation, a number of important steps

The Minister, Dr. Ben Ngubane, presents the President, Mr Thabo Mbeki, with the outputs of the Foresight Project, 23 March 2000.



Science and Technology

were taken. One of these was to set aside funds to be accessed through competitive bidding. These funds constitute the Innovation Fund. The Innovation Fund is a programme of support that addresses problems "serious enough to impede socio-economic development or affect our ability to compete in products and services". The funds are intended for large-scale projects and involve a significant component of R&D. The period under review saw the Innovation Fund grow by as much as 66% from its 1999/2000 funding base of R75 million. The Innovation Fund Trust has been set up to give strategic direction to the programme and it is envisaged that the operational management will be transferred to an organization such as the NRF which has infrastructure appropriate to a grant-funding agency. Some of the three-year projects included in the programme are:

- Biotechnology-based vaccines: Newcastle disease - impact on small-scale poultry farmers.
- Application of probiotic technology to improve existing baby and young children cereals for prevention of diarrhoea (the leading cause of death among children under the age of five in SA).
- Vaccine to reduce the incidence of cervical cancer (predominant in women from previously disadvantaged communities).
- Biotechnology to address "wood splitting" of Eucalypts: SA's most extensively grown hardwoods (problem renders them only good enough for pulping).
- Biotechnology - drought and disease-resistant crops.
- Exploiting our natural flora for the generation of "super drugs" (addressing acquired multiple drug resistance problems).
- Biological control agents as opposed to chemical methods for controlling insects, weeds and crop disease.
- Identification and characterization of moulds (fungal strains) capable of producing fibrolytic enzymes that can specifically improve digestibility of SA animal feed formulations.
- Developing the official languages of SA through speech technologies: SA English, isiZulu, isiXhosa, Sesotho and Afrikaans - pilot with the hospitality industry.

Science and Technology

- Seasonal weather forecasting through computer-based modeling of climatic systems.
- Ultrasonic technology resulting from military work with unique algorithms and methodology for developing low-cost Doppler waveform analysis (DWA) for specific application by registered nurses in antenatal clinics.

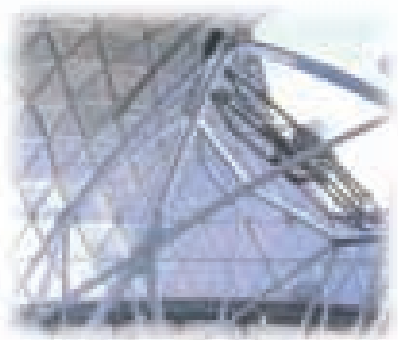

- Development of national on-line vehicle identification system based on metallurgical fingerprinting.
- Communications infrastructure consisting of satellite broadcasting for Internet downloads, distribution into villages via wireless technology and uplink via a GSM service provider - powered utilizing renewable energy such as biogas and solar power.
- South African Integrated Spatial Information System (ISIS 2000) for the new millennium: Access to agriculture (soil, climate, water and environmental factors), biodiversity and coastal zone related information is critically important to the research community, decision makers and civil society in terms of land use planning and development.
- Development of low-maintenance, self-sustaining biological (passive) systems for the treatment of contaminated mine and industrial effluent.
- Recycling polythylene terephthalate (PET: one of the only plastics that is truly

Science and Technology

recyclable) for the production of second generation products such as fibres, fibre-fill, carpets, strapping, automotive parts and many more consumer products.

- Development and implementation of an advanced process for refining PWG zinc to special high-grade zinc: technology to facilitate low processing costs for increasing SA proportion of world production.
- Establishment of technologies for the development of a local titanium metal industry: beneficiation of one of the country's most significant natural resources.
- Development of special zirconia products from dissociated zircon: SA has 45% of the world's zircon deposits.
- Development of technologies and capabilities in high-pressure die-casting (HPDC) for aluminium: producing components of high integrity for automotive components.
- Closed Loop Automated Manufacturing (CLAM) technology: cast to form hollow back tooling in a closed loop environment: manufacturing tooling across most conversion technologies, including injection moulding and pressure die-castings without the laborious conventional metal hogging process.
- Novel food fortification product from fish waste: using fish heads - normally regarded as waste - for the production of a powder rich in omega-3 fatty acids, protein and calcium to be used in the fortification of a staple diet.
- Anti-malarial medicines from the medicinal plants of Southern Africa - new agro-processing businesses for the supply of extracted plant material to be used in development of novel anti-malarial drugs.

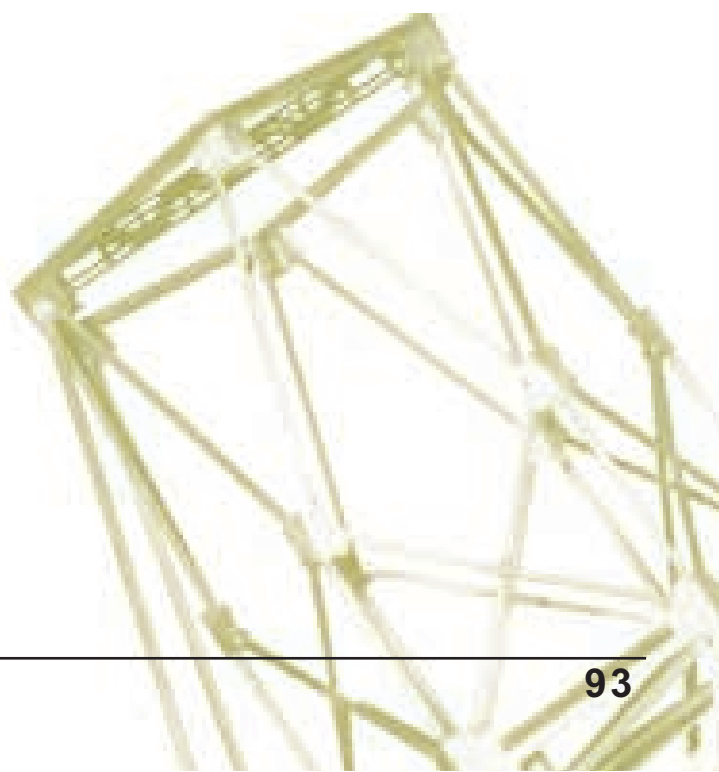

Science and Technology

■ Equipment Placement Programme

DACST launched this programme with the objective of addressing the deficit in state-of-the-art equipment/technology infrastructure at SET institutions. An earlier survey of South African research institutions, higher education, private and public sector laboratories established that by the year 2002 half a billion rand's worth of SA scientific research equipment would become obsolete. In the face of shrinking budgetary allocations to science councils, DACST committed funding to strategic investments in equipment and technology platforms (facilities). Some of the highlights include:

A laboratory facility in Port Elizabeth for non-woven and bonding equipment to meet the needs of the formal and informal textile sectors. This sector is targeted as a potential high-growth area. The facility will be utilized by 25 to 30 researchers from the CSIR, industry, universities and technikons.

Placement at Mintek of Dynamic Reaction (Collision) Cell ICP Mass

Spectrometer. Mining and minerals beneficiation are acknowledged as key growth areas for Economic Action Plan. Limitations of present ICP-MS instrumentation include the inability to determine environmentally sensitive elements. Ten researchers at Mintek will be fully trained along with approximately 24 students. Indirectly up to 10 researchers from Mintek and other institutions will use the equipment.

Placement at HartRAO of a hydrogen maser. HartRAO is the only radio telescope in Africa and is in constant demand to participate in Very Long Baseline Interferometry (VLBI) projects. Radio astronomy is used for determining changes in global warming, for example.

Sutherland, SALT and smiles are synonymous.



Systems, Evaluation and Resourcing

Establishing a mobile phone testing facility at the SABS. There is a need for an accredited laboratory to conduct tests on radiation levels of mobile phones. The facility will also allow for research to develop standards for radiation levels and codes of practice.

■ SET statistical indicators

A highly successful seminar on the measurement of innovation activities in developing and emerging economies was organized by DACST, in conjunction with the OECD, on 28 - 29 March 2001. The seminar was organized in line with DACST's observer status on the CSTP of the OECD and as part of OECD initiatives to increase interaction with non-member and developing countries. It was designed to bring together experts from OECD and non-OECD countries to exchange experiences in the measurement of technological innovation.

The stated objectives of the seminar, which were unanimously acknowledged as being met, were:

- consider a broader use of innovation surveys as a complementary means of measuring science and technology activities. The question on everyone's mind was whether a different approach to measuring development and more particularly innovation should be used, this in the context of developing countries. To provide an exchange of experiences between OECD members and those non-OECD countries which have conducted innovation surveys.
- To make OECD countries' experience in the measurement of innovation available to a broader range of countries.

In all 132 delegates attended the seminar and 29 papers were presented in the five seminar sessions. The seminar drew participants from multilateral bodies such as the OECD, World Bank, Eurostat, European Union (EU), the Ibero American Network of Science and Technology Indicators (RICYT) and the SADC. Country-specific participation included delegates

Systems, Evaluation and Resourcing

from Argentina, Brazil, Russia, Hungary, Canada, the Netherlands, Tanzania, and the Peoples Republic of China (PRC). There was enthusiastic local participation from SA government departments, science councils, business and academic institutions.

Some of the key outcomes and recommendations emanating from the seminar were:

- A forthcoming publication on the proceedings of the seminar.
- The output of this seminar to initiate a process that would see non-OECD countries making a significant input into the revision of the OSLO manual (the primary framework for conducting innovation surveys).
- To investigate statutory mechanisms that would ensure high response rates to surveys and thereby ensure the provision of good-quality data by organizations.



Systems, Evaluation and Resourcing

- To develop a coordinated and integrated approach to data collection across related state organs.
- To consider developing surveys of regional systems of innovation.
- The necessity for continued research in defining innovation due to the complexity of innovation process in developing economy context.
- The urgent need for meaningful surveys to be developed for the services sector.
- The need for continuous surveys to ensure good-quality data to assess impact on and of policy and instruments.
- The necessity for better resourced and planned surveys to increase response rates.

Research and Technology Development



Technology Research and Development

The South African manufacturing industry, the service sector (communications, finance, hospitality industry, security, etc.) and the knowledge industry (higher education, research institutions, etc.) are increasingly finding that they operate within a technology environment that is incredibly fast paced and highly competitive. The work of this Directorate focuses on:

- driving the Science, Engineering and Technology (SET) community, both private and public, into the technology areas that are emerging as core technology areas of the future;
- introducing interventions that facilitate technology transfer and diffusion, particularly for small, medium and micro enterprises (SMMEs);
- introducing interventions for transfer of appropriate technology to accelerate economic development, growth and an improved quality of life within rural communities.

Important activities and initiatives that are underway to reach these objectives include the following:

THE NATIONAL SCIENCE AND TECHNOLOGY FORESIGHT EXERCISE AND FOLLOW-UP

- **Dissemination of the recommendations of the Report**

The National Research and Technology Foresight (NRTF) study report was officially launched in March 2000. This exercise projected 15 to 20 years into the future, and identified a suite of technologies and trends in technology development that are likely to have the largest impact on South Africa's economic and social development. The findings of the study were fully reported in a composite report which brought together all the recommendations from the various sectors as well as for individual sectors of industry, namely agriculture and agro-processing, biodiversity, financial services, energy, environment, health, information and communication technologies, manufacturing and materials, mining and metallurgy, crime and crime prevention, tourism, and youth.

Follow-up activities entailed dissemination of the recommendations from the various sectors

Research and Technology Development

delivered a suit of technologies that have the potential to impact positively on the socio-economic needs of our country, it became necessary to focus on a shorter term, and develop roadmaps that must be followed to realize the immediate potential inherent in some of the technologies.

Three areas were chosen for the roadmaps, namely Information and Communication Technologies (ICT), Advanced Materials, and Biotechnology and Bioinformatics. These areas were chosen because of the importance of the technology developments in these areas and also because of the tremendous impact they have on a wide range of other technologies included in the Foresight study. The objective is to formulate, in all three sectors, the linkage between technology resources that need to be developed, and the exploitation of future market opportunities. Technology Roadmapping is understood for these purposes to be a planning tool and seeks to identify, select and develop technology alternatives by technology generators and users, including industry, academia and

to as many people as possible within SA. Foresight roadshows were therefore arranged and successfully presented to representatives from academia, civil society, industry and government. The full set of the Foresight reports, including copies of the macro-scenarios synthesized for use during the study, were also distributed. To date, the following areas have been covered: Cape Town, Pietersburg, Port Elizabeth, East London, Durban and Bloemfontein.

- **Technology Roadmaps**

While the focus of the National Research and Technology Foresight (NRTF) study was 15 to 20 years into the future, and

Technology Research and Development

government, who pool their resources to drive developments in the agreed areas. Expected outputs from the Technology Roadmapping include national research strategies, revised SET human resource development strategies and SET infrastructure investment strategies. A steering committee to oversee the project has been established and consensus was achieved in terms of the methodology for achieving the objectives. Progress on the project will follow in the next period of reporting.

- **GODISA programme**

As part of its foreign aid programme the European Commission made a grant available for the support of the development of SMMEs in South Africa. With DACST as partner, this programme, the GODISA programme, will support the establishment of technology incubators, and pilot projects in technology demonstration centres and innovation support centres. During the period under review a programme management unit was set up to support DACST with implementation. Progress was also achieved in finalizing the selection of the organizations for the projects. A report on achievements of the units described below will be presented in the next review period.

Technology Demonstration Centre

A consortium led by Mintek was selected to establish a technology demonstration centre (TDC). This Centre will be dedicated to the small-scale mining and associated value added sectors. Its main purpose will be to demonstrate and encourage the use of new and appropriate mining and associated technologies within this sector.

Innovation Support Centre

A consortium led by the University of Natal was selected to establish an innovation support centre (ISC). This Centre will focus on embedded systems and information technologies. Its main purpose will be to optimize and commercialize innovative technologies in this sector.

Technology Incubator

A consortium led by the CSIR was selected to establish a technology incubator (TI). This incubator will focus on information and communication technologies, with the core emphasis being on smart software for wireless

Research and Technology Development

applications. Its main purpose will be to house, stimulate, grow and launch technology-rich start up businesses in this sector by providing a protected environment in which these businesses can grow.

TECHNOLOGY DIFFUSION

There are a number of technology transfer/diffusion models for providing support to the SMME community with a focus on demonstration and training in the new technologies and to a large extent on business management and marketing. DACST recognized that a gap existed in terms of outreach programmes that included:

- Support for technology assessment;
- Technology audits in focused SMME sectors;
- Technical assistance, for example funding for two weeks' services of a process engineer for particular SMMEs;
- Linkage with knowledge/technology sites such as technikons and universities.

The programme that has been designed to address these issues is the Technology Stations Programme (TSP). The technikon community was recognized as the best platform from which to establish a knowledge/technology site link with technology-based SMMEs. The programme offers shared-use cooperative arrangements for equipment that forms part of the technikons' technology infrastructure in a specific technology area, e.g. electronics, and also for equipment that the DACST programme may place there for dual benefit (technikons and SMMEs). The first technikons to come into the TSP programme included Technikon North West in Chemicals, Mangosotho Technikon in Chemicals, Pretoria Technikon in Electronics and Free State Technikon in Metals/Value-adding. During the year 2000 newcomers included Peninsula Technikon in Textiles, Vaal Technikon in Composites and Port Elizabeth Technikon in Automotive components: mechanical engineering.

Technology Research and Development

POVERTY RELIEF, INFRASTRUCTURE INVESTMENT AND JOB SUMMIT

- **Agro-processing**

The specific focus of this programme is on value addition to available local resources, most of which fall within the agricultural sector. Hence most of the projects focus on processing natural animal fibres, plant fibres and indigenous foods. The products envisaged to be manufactured from these projects all have allocations in niche markets, which represent higher value products. All of the projects have been designed to form a holistic value chain, which comprises of growing, processing, value addition and marketing of the end product. Furthermore, the process has been developed so that every part of the value chain is sustainable and profitable.

- **Phumani Paper-Hand Paper Technologies Programme (HPTP)**

The project involves developing appropriate technologies to convert locally available biological resources to paper pulp, which is

then converted into paper products of various kinds (the biological resources used depend on the region). It also involves training unemployed people from target communities in the use of these technologies and establishing local manufacturing facilities (craft factories) and training participants in the project in the required business skills to develop their newly acquired technological capacity into sustainable businesses.

- **The acquisition of superior cattle genetic material**

The project's purpose is to buy indigenous Nguni cattle bulls of superior genetic quality that can be distributed to selected rural communities to improve the quality of their cattle types. Such distribution will be done in cooperation with the provincial Departments of Agriculture of the Northern Province (NP) and Eastern Cape (EC). The project directly addresses the problem of consumptive and passive rural economy that falls dismally short of the present and growing socio-economic needs of these areas.

International S&T Cooperation

A model of the South African Large Telescope (SALT).

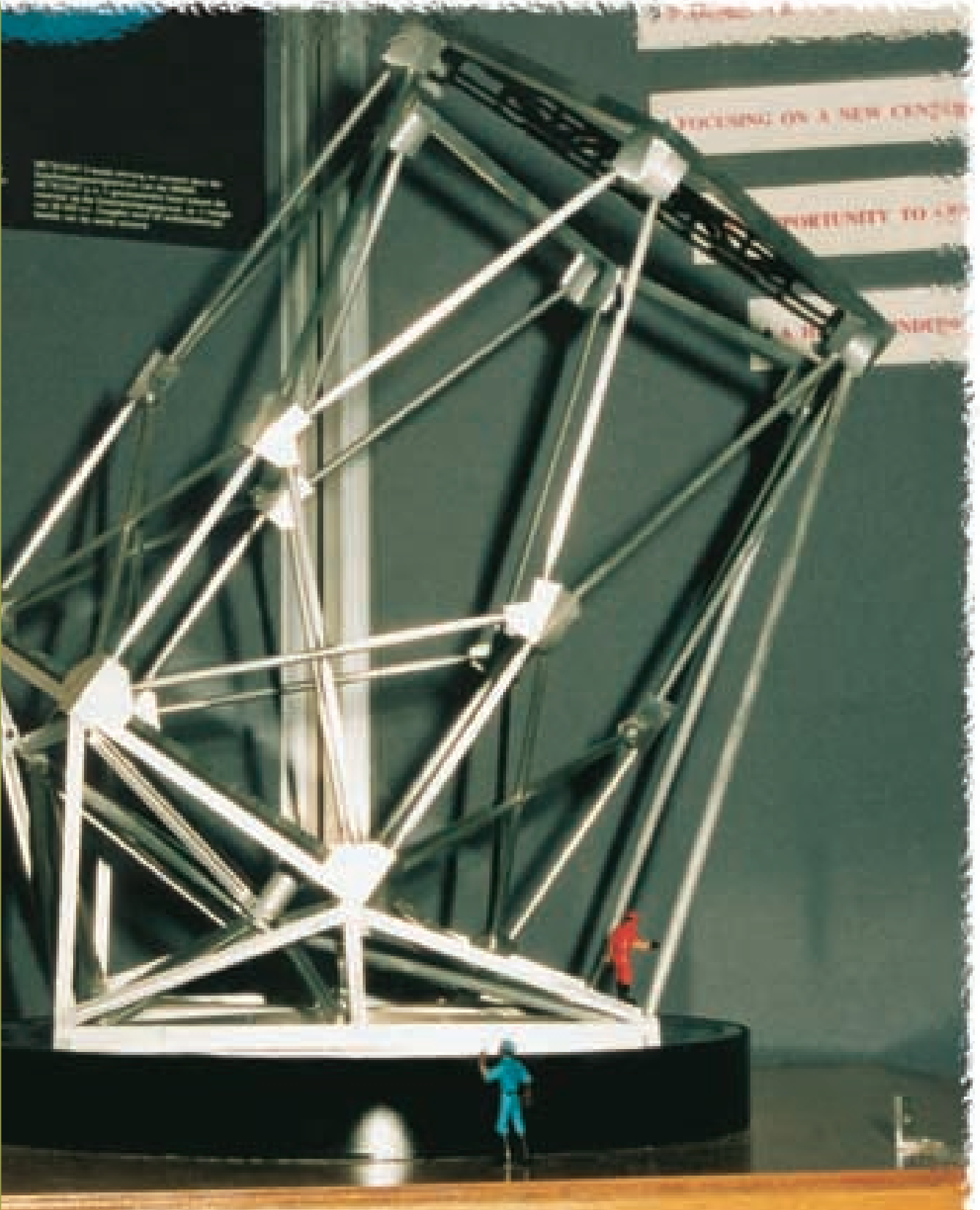

International S&T Cooperation

The mission of the Directorate is to support national objectives and priorities through proactive bilateral and multilateral engagement in the fields of science and technology (S&T). The Directorate views its main priorities in this regard as -

- leveraging international support for S&T skills development and national S&T initiatives;
- benchmarking the quality of national research and development (R&D);
- knowledge creation and dissemination; and
- internationalizing South African S&T.

Important activities and initiatives undertaken by the Directorate during the period under review include:

- **The establishment of a framework for a more integrated national approach to international relations in science and technology**

The establishment of the Science and Technology Cooperation Committee (SATCCOM). This body includes all relevant government departments and has as its main objective the promotion and coordination of S&T at state administrative level.

- **Improved administrative systems**

The development of the Administration Manual

for the Purpose of Conducting Bilateral International Scientific and Technological Cooperation. The aim of the manual is to support the implementation of the Policy on Bilateral International S&T Cooperation.

- **Developing an "intelligence" in matters related to international cooperation**

Surveying South Africa's R&D potential and S&T involvement in international multilateral organizations (IMOs). The survey is intended to assist DACST and other relevant departments in the development of common S&T approaches and strategies vis-à-vis these organizations. The Directorate is currently preparing an overview of the role of the provincial governments in national R&D and the extent of their involvement internationally.

- **New International Agreements**

During the period January 2000 to March 2001 this Directorate initiated and facilitated the signing of bilateral agreements on scientific and technological cooperation with the Islamic Republic of Iran, Nigeria and Cuba. Negotiations were also pursued with 22 potential partners in this domain, including Australia, Japan, Spain, Norway, Brazil and Senegal.

International S&T Cooperation



*Dr Chris Scheffer
Director: International Science
& Technology Cooperation*

- **Promoting International cooperation and collaboration**

During this period bilateral and multilateral exchanges on S&T cooperation were held with countries and organizations such as Germany, France, the European Union (EU), Iran, the Organization for Economic Co-operation and Development (OECD), Nigeria, Algeria, the People's Republic of China, the Indian Ocean Rim Association for Regional Co-operation (IOR-ARC) and Japan.

Science and Technology Agreements Committee (STAC) Fund. Since its inception in 1996, STAC has through the offices of the FRD (now NRF) effectively serviced inter-governmental S&T agreements and multilateral activities. For the period January 2000 to March 2001 the STAC budget allocation exceeded R9 million and serviced over 27 bilateral and multilateral agreements.

Lead Programmes Fund. This Fund was established to enhance existing international cooperation in the fields of biotechnology, new materials, information

International S&T Cooperation

and communication technology, environmental management, rural development, and urban renewal. During the first round (1999 - 2001), the Lead Programmes Fund successfully leveraged international R&D support and established viable consortia between South African science councils and CIRAD (France), ALCOA (USA), Rolls Royce (United Kingdom) and IVL (Sweden), among others.

Regional Science and Technology Programme.

This programme was established to facilitate and promote science and technology cooperation between South Africa and other SADC countries and stimulate collaboration between South African institutions and partners in the SADC and Africa with the view to contributing to capacity building and development of R&D infrastructure. The main priorities identified under the Regional S&T Programme include water management, cross-border pollution, food technology, indigenous knowledge systems, information and communication technologies, soil management, HIV/AIDS, etc. During the first round (2000 - 2003) of this Programme DACST received in excess of 80 project proposals of which eight received funding.

• International Ventures

This period also witnessed the ground-breaking ceremony of the international astronomy project The Southern African Large Telescope (SALT) on 1 September 2000 at Sutherland. Government and academic institutions in several countries have become partners of South Africa in SALT, including the Hobby-Eberly Telescope Board (USA) and Poland.

The launch of the Satellite Laser Ranging System at the Hartebeeshoek Radio Astronomical Observatory in Partnership with NASA, on 20 November 2000.

The SAFARI 2000 survey of pollutants over the SADC region in August 2000. The project involved international partners, including scientists from SADC member states.

Science and Society



National Science, Engineering and Technology Week, 2000.



Department of Arts, Culture, Science and Technology

Science and Society

The Directorate: Science and Society positions itself at the crossroads of science, engineering and technology (SET) and society. Its main goal is to promote public awareness, appreciation, critical evaluation and understanding of science, engineering and technology through systematic, coherent and coordinated projects. A range of very focused activities that require a high degree of public participation have been designed in broad consultative processes and implementation by this Directorate in partnership with the nine provinces, a number of SET organizations and many other interest groups.

PUBLIC UNDERSTANDING OF SCIENCE, ENGINEERING AND TECHNOLOGY (PUSET) ACTIVITIES

- **National Science, Engineering and Technology (SET) Week 2000**

SET Week has proved to be a path-breaking initiative aimed at raising public awareness around SET. The success of the Year of Science and Technology in 1998 (YEAST '98) served as a platform for the Department to continue to raise public awareness around SET issues. The implementation strategy for SET Week centres on a

three-year cycle with three provinces per year assigned to host SET Week within this cycle. The host provinces for the year 2000 were North West Province, the Western Cape and the Northern Cape. For 2001 it has been KwaZulu-Natal, the Eastern Cape and the Northern Province; and for 2002 it will be Gauteng, the Free State and Mpumalanga. This strategy is important in that it allows optimum utilization of a thin resource base.

The theme for the project is "Taking Science, Engineering and Technology to our people". The thrusts are indigenous knowledge systems, outreach science, engineering and technology, and building community partnerships through science, engineering and technology. The target audience included learners, educators, women, rural communities and the general public.

The project was run from 20 - 25 March 2000 and again from 5 - 10 March 2001.

Sponsors of SET Week March 2000 included ARMSCOR, the SABC, Sunday World newspaper, Burgers Park Hotel, Hewlett Packard and Sonovision Studios, and SET Week March 2001 included BUSISIWE Personnel and Construction, Sasha Signs, Burgers Park Hotel, the SABC and Sunday World.

Science and Society

The Foundation for Education Science and Technology (FEST) served as partners with DACST in implementing the project.

- **The National Science and Technology Camps for Girls 2000**

The idea behind the National Science and Technology Camps for Girls is to ensure that they are motivated and influenced before they reach the critical stage of choosing their careers. In 2000 Camps were held in three centres simultaneously. The nine provinces were divided into three clusters with one province acting as host. The host provinces included the Free State, the Eastern Cape and Mpumalanga. Girls that were targeted for these Camps were from grade 6 to 10. Two hundred and seventy girls (30 per province) and 18 teachers (male and female with two from

National Science and Technology Camp for Girls, 2000



each province) were involved in the project. The themes around which the 2000 Camp activities were programmed included:

- Minerals and Energy
- Gender dimensions of SET
- HIV/Aids
- Careers in SET
- Role modelling

Sponsors of the Girls Camp 2000 included Telkom and ESKOM. The DACST partner in implementing the Girls Camp 2000 was PROTEC.

- **Reference Group for Women in Science and Technology**

The Directorate has initiated a number of processes to redress the severe **under-representation of Women** in the Science and Technology career arena.

DACST has established a task team of stakeholders to initiate a

Science and Society

The Deputy Minister at FEST. Dr Puris, CEO of FEST stands next to her

Reference Group for Women in Science and Technology. The Reference Group will determine research priorities and programme interventions that will minimize the gender-biased challenges in the science and technology arena. This will have a direct impact on effecting the human resource development policies of government. The Reference Group will also play a lobbying and advocacy role in ensuring that adequate resources are committed to research and development that will have as an outcome a definite improvement in the quality of life of women. Efforts are currently being concentrated on research prioritization and on developing a constitution for the Reference Group.

- **Science Communication Workshops**

Scientific research needs to be communicated in the most effective manner and format to various communities and stakeholders for various reasons - be it to inform, request cooperation, partnerships, support, need for clarification, raise basic awareness, elicit responses, etc. The aim of this project is to encourage the communication of scientific work by both scientists and public information officers in a planned and managed

way in order to transfer the message to various targets effectively and efficiently. As part of the basic principle of the Public Understanding of SET, one-day Science Communication Planning and Media Skills Workshops are hosted.

These workshops are unique in South Africa and come at a crucial time in opening up science and technology to the public. Six workshops were run for science councils, universities and parastatals in South Africa.

- **Science and Technology Journalism Awards**

During the Year of Science and Technology (1998) the Science and Technology Journalism awards were launched as a collaboration project between the eight science councils and DACST.

The Science and Technology Journalism awards were launched to:

- Encourage journalists to report on science and technology and to give recognition to those journalists making the best contribution in this field.



*Ms Kebogile Dilotsohle
Director: Science and Society*

Science and Society

- Sensitize journalists and the public to the fact that science and technology constantly presents us with new research findings that show significant possibilities and impact in our daily lives.
- Highlight the coverage of science and technology in the media.

Since 1998 there have been seven categories, including national original newspaper, community newspaper, specialist periodical, best hard news item in any media, best radio programme or contribution to a radio programme, best television programme or contribution to a television programme and best contribution in a consumer publication, including magazines. Two extra awards, namely the best indigenous language contribution and the most highly commended, have been introduced recently. The overall award was received by the Mail & Guardian in 1999 and the Financial Mail in 2000.

- **DACST Science Radio Programmes**

One of the lessons learnt in 1998 was that radio is a very powerful tool especially when

attempting to reach rural communities. Ten science programmes were co-produced by the Science & Society Directorate and SABC Radio between November 2000 and January 2001. The programmes were broadcast in February 2001 in the nine indigenous languages. The content of the programmes was mainly based on the activities of the Ministry and the Science and Technology Branch. The programmes were produced at a cost of a million rand. In addition to these programmes the Science and Society Directorate has positioned the Science and Technology Branch and some research councils, e.g. the CSIR, ARC and NRF, through free slots offered by Lesedi FM, Motsweding FM and Ukhozi FM.

- **Expo for Young Scientists**

One of the numerous awards that the Directorate is involved in, is the floating shield for Outstanding Communication of Science that was awarded at the National Finals of the Expo for Young Scientists in 1999. This annual award encourages not only the development of scientific thought in our youth but goes further to encourage the effective sharing of

Science and Society

scientific knowledge. The award will be presented annually for the next 10 years at the National Finals of the Expo for Young Scientists. The first two sets of recipients of this award came from Mpumalanga and the North West Province, respectively.

META-INFORMATION

To a large degree the year 2000 activities of the Subdirectorate focused on legislative and regulatory interventions to facilitate the achievement of the goals defined for Meta-information systems and management. The activities of the Subdirectorate included:

- Matters related to bringing into effect the South African Library for the Blind Act, 1998, and its Regulations on 1 April 2000. This Act acknowledges the right of access to information for the visually disabled.
- The Regulations of the Legal Deposit Act, 1997, were amended to clarify requirements regarding the legal deposit of audio-visual documents.
- A Progress Report on library and information services (LIS) in South Africa as submitted to

MINMEC on 24 August 1999 was published in January 2000. The Report deals with the constitutional implications of the national/provincial relationship on LIS matters, the identification of priorities and optimal utilization of scarce resources, and the improvement of levels of support for rendering library and information services.

The Department facilitated the process to clarify matters relating to the development of new provincial legislation for the provision of library and information services to communities. This was necessary to bring provincial legislation in line with Schedule 5, Part A, of the Constitution of the Republic of South Africa, which stipulates that "libraries other than National Libraries" are a functional area of exclusive provincial legislative competence.

The in-house journal, Meta-info bulletin, published quarterly, is aimed at disseminating information on the activities of the Subdirectorate and Meta-information matters in general. The Subdirectorate's web site was expanded and upgraded and the full texts of various publications were added.



Mr Arno Webb
Director: Science
and Technology
Programme
Coordination

Science and Technology Coordination

The Directorate for Science and Technology Coordination was established to coordinate the manifold activities of the Branch.

Its objectives include coordinating DACST inputs into interdepartmental projects, reports and high-level committees such as the Committee of Heads of Science Councils and providing a secretariat for such committees where appropriate. The Secretariat of the National Advisory Council on Innovation is accommodated in the Directorate.

LEGISLATION ADMINISTERED

The following Acts are administered by the Directorate:

- Human Sciences Research Act, 1968
- National Library of South Africa Act, 1998
- National Research Foundation Act, 1998
- Natural Scientific Professions Act, 1993



National Science, Engineering and Technology Week, 2000.

Science and Technology Coordination

- Public Finance Management Act, 1999
- South African Library for the Blind Act, 1998

POLICY DEVELOPMENTS

The Directorate coordinated the Business Plan activities of the Branch.

Project monitoring and development of science and technology (S&T) policy processes were managed by the Directorate through e.g. Pulse Rate Meetings, Strategic Planning Workshops, National Science and Technology Awards, and gala dinners, and the administration of financial assistance towards projects promoting the development of the S&T system.

The National Advisory Council on Innovation had four meetings during the reporting year. Its Executive Committee as a rule meets once a month.

The most important issues dealt with by the Council during the reporting year included:

- The distribution of the Science Vote, guided by

visits to science councils, analysis of their annual reports and meeting of national imperatives.

- The assessment of the National System of Innovation through the hosting of a workshop ("Innovation and the Knowledge Economy" facilitated by Jim Mullin, a Canadian expert of international stature).

- A joint study with the NSTF on growth and innovation. The study concentrated on the perspectives on the interaction between economic growth, science, technology and human capital.



Mr Andile Xaba,
Chief Director:
Corporate
Communication

Corporate Communication Unit

The Corporate Communication Unit came into being as a result of the implementation of the Department's Integrated Implementation Programme (IIP). The process saw the merging of the Directorate: Communication and the Subdirectorate: Events Management.

Goals and Objectives

The Chief Directorate aims to market, promote and publicize the profile and role of the Department, Minister and Deputy Minister, both nationally and internationally.

Strategic objectives include:

- Releasing accurate, honest, relevant and high-quality communication products;
- Regular interaction with the media to ensure optimal and fair coverage of the activities of the Department, in order to create a positive awareness of the Department as one aimed at service delivery;
- Regular communication with the different programmes attached to the two branches of the Department, and

- Integrating the above-mentioned communication activities with the conceptualizing, planning, coordination and management of events.

Restructuring

The establishment of the Corporate Communication Unit, while adhering to the needs of the Department in terms of the Integrated Implementation Programme, also had to keep in mind the COMTASK proposals for restructuring the communication function of the government in general. (COMTASK was a task group formed by the then Deputy President in 1995 to investigate and to make recommendations on Government Communication).

The restructuring process, started during 1999, was completed during 2000 when the Management Plan for the Corporate Communication Unit was approved.

The structure eventually approved for the Corporate Communication Unit accommodated both the guidelines provided by the GCIS (based on the

Corporate Communication Unit

COMTASK recommendations) and the requirements contained in the IIP.

The structure provides for a Directorate: Communication and a Subdirectorate: Events Management, both reporting to the Chief Director: Corporate Communication, as head of the Unit.

With its structure approved during the year under review, the Unit assumed the core functions of managing events and conducting communication on behalf of the Department by -

- exploring, assessing and executing communication opportunities;
- coordinating communication activities;
- designing communication plans for such activities, and
- producing suitable products to support the communication function.

The activities involved are categorized as:

- Conferences and Workshops;
- International Festivals;
- Awareness Projects and Events;
- Launches and Openings;
- Public Holidays (e.g. Freedom Day, Women's Day and Heritage Day), and
- Special Projects.

Activities for 2000 - 2001

During the period under review the Department was responsible for a wide variety of projects, in regard to which the Unit assisted with the necessary media arrangements and management of events.



Corporate Communication Unit

Dr Ben Ngubane and Mrs Sheila Ngubane arrive at a DACST event.

COMMUNICATION

Activities of this Directorate included issuing statements, inviting the media, arranging radio and TV interviews, placing articles in newspapers and compiling media packages.

Projects included:

- Parliamentary Media Briefing for the Minister, Cape Town, 10 February 2000;
- Unveiling of the Nelson Mandela Museum at Umtata, Qunu and Mveso, 11 February 2000;
- African Renaissance Colloquium, Johannesburg, 21 February 2000;
- Music Industry Task Team (MITT) hearings, Johannesburg, 23 February 2000;
- Announcing the winners of the competition for the design of the Women's Monument, Pretoria, 8 March 2000;
- The announcement of the research results of the National Science, Engineering and Technology Foresight Study, Pretoria, 14 March 2000;
- The Launch of the Science, Engineering and Technology Week, Pretoria, 10 March 2000;
- Freedom Day, Kwaggafontein, 27 April 2000;
- The Budget Vote function of the Minister, Cape Town, 16 May 2000;
- Africa Day Celebrations, Pretoria, 25 May 2000;
- Announcement of Freedom Park Board of Trustees, Pretoria, 31 May 2000;
- The Launch of the Crime Prevention Research Unit, Pretoria, 28 June 2000;
- Unveiling of the Women's Monument, Pretoria, 9 August, 2000;
- Ground-breaking Ceremony of the Southern African Large Telescope (SALT), Sutherland, 1 September 2000;
- Parliamentary Media Briefing for the Minister, Cape Town, 19 September 2000;
- Heritage Day, Pietersburg, 24 September 2000;

Corporate Communication Unit

- Launch of the Satellite Laser Ranging Facility, Hartebeeshoek, 20 November 2000;
- Disabled Artists Concert, Durban, 25 November 2000.

The celebrations around Women's Day, Heritage Day and Freedom Day had special media impact, and was covered live by both the electronic and print media. The Chief Directorate had positive interaction with the media during these events.

There are initiatives to continue building relationships with the media by frequent formal and informal interaction.

EVENTS

The Subdirectorates managed or assisted with a number of events in both urban and rural areas. Events and projects included the following:

- EXPO 2000 in Hannover, Germany (June 2000)
- Anglo-Boer South African War Conference, Durban (29 - 31 August, 2000)

- EU/SA Film Symposium
- Disability in the Arts Concert, Durban
- Launch of Decade of Mobilization against Racism (16 December 2000)
- Arts, Culture and Heritage Publication (ARTS 2000)
- The unveiling of the Women's Monument, Pretoria (9 August 2000)
- Heritage Day 2000 (24 September 2000)
- Ma Afrika 2000 (27 October 2000)
- Opening of the Nelson Mandela Museum (11 February 2000)
- SADC Council of Ministers Meeting (February 2000)
- MOBILAS-6 at HartRAO (20 November 2000)
- Southern African Large Telescope (SALT) - Ground-breaking Ceremony, Sutherland (1 September 2000)
- Kopano Conference at Dikhololo in Brits, North West Province (20 - 25 July 2000)



A crowd at a DACST event.

Corporate Communication Unit

- OECD Seminar, CSIR Conference Centre (28 - 29 March 2001)
- Freedom Day 2000 at the Kwaggafontein Stadium in Mpumalanga
- Indigenous Music Conference, Durban Playhouse (5 - 7 October 2000)
- Africa Day 2000

Some of these events deserve special mention. The date of the opening of the Nelson Mandela Museum coincided with the 10th anniversary of former President Nelson Mandela's release from prison. The event took place at three venues, namely Mvezo (Nelson Mandela homestead), Qunu (ground-breaking ceremony for the Nelson Mandela Youth and Heritage Centre), and Umtata (museum at the Bhunga Building). The function in Umtata was attended by approximately 30 000 people, which proves that a large number of South African citizens were reached.

The Arts, Culture and Heritage Guide, an annual publication that promotes and exposes South African arts, culture and

heritage nationally and internationally, includes a list of festivals, arts, cultural and heritage events and places of interest. Three thousand copies of Arts 2000 were distributed as complimentary copies to various institutions, government departments, embassies, and arts, culture and heritage organizations. Mail & Guardian, the producers, distributed the publication for sale to bookshops across the country. High schools and students in tourism and travel agencies received complimentary copies.

The National Aeronautics and Space Administration (NASA) of the USA developed MOBLAS-6 and supplied it to South Africa. NASA approached the Department of Arts, Culture, Science and Technology (DACST) to fund the installation and operation of MOBLAS-6 at HartRAO, in accordance with discussions at the US-SA Binational Commission. The role of DACST was to co-fund and organize the launch at HartRAO on 20 November 2000. The Events Management Subdirectoriate was responsible for organizing the entire event.

Another event of importance to the scientific community of South Africa was the ground-

Corporate Communication Unit

breaking ceremony at the proposed site for the Southern African Large Telescope (SALT) at Sutherland on 1 September 2000. South Africa, together with international partners, plan to construct SALT, a 10 m class telescope for optical/infrared astronomy. SALT, based on the design of the Hobby-Eberly Telescope (HET), which was recently completed at the McDonald Observatory in Texas, will give South Africa and its partners access to the single most powerful optical telescope in the Southern Hemisphere. The scientific scope of SALT will extend from searching for planets around neighbouring stars to the study of the most distant objects in the Universe.

The role of the Department was to fund and organize the SALT Ground-breaking Ceremony. The Events Management Subdirectorates was responsible for the organization in terms of normal arrangements like facilitating transfer of funds, invitations, catering, protocol, transportation and the programme.

Kopano (meaning coming together/ gathering) was the initiative of the International Arts and Culture Directorate in the Arts and Culture Branch to promote cooperation between South African and the Southern African Region. This was the first

opportunity where countries and provinces could talk about matters of common interest, where they could exchange ideas and for the first time share common ground that will lead to bilateral exchanges between countries and the South African provinces and their neighbours.

Kopano took place from 20 - 25 July 2000 at Dikhololo in Brits, North West Province. The Events Management Subdirectorates arranged the conference and took responsibility for all the arrangements once the delegations arrived in South Africa. On 22 and 23 July a cultural programme was arranged for the delegates. The cultural excursions included places like the Sterkfontein Caves, a cultural concert, and a visit to Gold Reef City.

Through its Communication Unit, the Department was positioned and enabled to be involved at all levels of government, namely national, provincial and local.



*Ms Nobubele Ngele,
Director:
Human Resources
Management*

Human Resources Management

This programme provides human resource management, information technology, security, office and legal services to the Department.

Human Resource Management has responded to the challenges and changes brought about by the new management service framework with a major shift in thinking from the previous focus on rules to a new, more proactive focus on deliverables. Deliverables focused the attention on outcomes, results and value creation using the Public Service Regulations and White Papers dealing with human resource issues.

The key areas of work undertaken by the Directorate were:

1. Creating strategic clarity

- Developing HR systems and practices that drove employees' behaviours consistent with the departmental strategy.
- Developing a training and development plan that provided skills for delivering the strategy.

2. Acting as change agent

Redesigned HR systems to be congruent with changes.

3. Creating Intellectual Capital

- Crafted HR practices and policies that support employees.
- Developed measures for managing conflict.
- Recruited new talent to the Department and invested in employee learning.
- Developed measures to retain employees who are critical to the Department's success.

INFORMATION TECHNOLOGY

The key areas of work undertaken were:

- The establishment of the National Automated Archival Information Retrieval System (NAAIRS). This was achieved through a collaborative project involving SITA and the Department. It is a technological breakthrough achievement for the National Archives, who are in the vanguard of e-government, the rendering of public service via the Internet.
- The database was developed for the Technology Top 100 Awards and the

Human Resources Management

President's Award for Export Achievement. An evaluation process took place with various companies and the results of the survey were captured on the database. The reports generated from the database were published in the Business Day.

- Extensive developments were made with regard to the implementation of the workflow and document management project. The perpetual changing business dynamics are incorporated into the workflow processes on a regular basis.

SECURITY AND OFFICE SERVICES

The key areas of work undertaken were:

- Installation of the new automated security systems.
- Implementation of tighter security measures for information and document management.
- Provision of security support services during national events, such as Freedom Day, Heritage Day and the inauguration of the Mandela Museum.

HUMAN RESOURCES MANAGEMENT

TABLE 1: Employment and Vacancies

TABLE 1.1 - APPROVED ESTABLISHMENT BY PROGRAMME

PROGRAMME	APPROVED ESTABLISHMENT
Office of the Director-General	16
Office of the Minister	10
Office of the Deputy Minister	7
Programme 1 (Corporate Services)	156
Programme 2 (Arts and Culture)	77
Programme 3 (National Archives of SA)	200
Programme 4 (National Language Service)	74
Programme 5 (Science and Technology)	46
TOTAL	586

Human Resources Management

TABLE 1.2 - EMPLOYMENT AND VACANCIES BY PROGRAMME

PROGRAMME	NUMBER OF EMPLOYEES	VACANCY RATE	ADDITIONAL TO THE ESTABLISHMENT
Office of the Director-General	12	4	-
Office of the Minister	9	1	-
Office of the Deputy Minister	4	3	-
Programme 1 (Branch: Corporate Services)	114	42	1
Programme 2 (Branch: Arts and Culture)	62	15	-
Programme 3 (National Archives of SA)	166	34	-
Programme 4 (National Language Service)	48	26	-
Programme 5 (Branch: Science and Technology)	35	11	3
TOTAL	450	136	4

Human Resources Management

TABLE 1.3 - EMPLOYMENT AND VACANCIES BY SALARY BAND

PROGRAMME	NUMBER OF EMPLOYEES	VACANCY RATE	ADDITIONAL TO THE ESTABLISHMENT
Salary levels 1 - 2	52	22	1
Salary levels 3 - 5	91	27	-
Salary levels 6 - 8	192	43	-
Salary levels 9 -12	96	38	-
Senior Management Service	19	6	3
TOTAL	450	136	4

Human Resources Management

TABLE 1.4 - EMPLOYMENT AND VACANCIES BY NATURE OF APPOINTMENT

	NUMBER OF EMPLOYEES	VACANCY RATE	ADDITIONAL TO THE ESTABLISHMENT
Permanent	396	136	1
Probation	47		
Contract	3		3
Temporary	2		
Part time	2		
TOTAL	450	136	4

Human Resources Management

TABLE 2: Job Evaluation

TABLE 2.1 - JOB EVALUATION

	ESTABLISHMENT	NUMBER OF JOBS EVALUATED	NUMBER OF POSTS UPGRADED	NUMBER OF POSTS DOWNGRADED
Salary levels 1 - 2	74	0	0	0
Salary levels 3 - 5	118	4	4	0
Salary levels 6 - 8	235	1	1	0
Salary levels 9 - 12	134	4	4	0
Salary levels 13 - 14 (Professionals)	0	0	0	0
Senior Management Service	25	2	2	0
TOTAL	586	11	11	0

Human Resources Management

TABLE 3.1 - ANNUAL TURNOVER RATES BY SALARY BAND

SALARY BAND	APPOINTMENTS AND TRANSFERS	TERMINATIONS AND TRANSFERS	TURNOVER %
Level 1 - 2	0	7	13,46
Level 3 - 5	3	9	6,59
Level 6 - 8	1	10	5,21
Level 9 - 12	3	7	3,13
Professionals(13 - 14)	0	0	0
Senior Management Service	0	0	0
TOTAL	7	33	5,11

Human Resources Management

TABLE 3.2 - REASONS WHY STAFF LEFT THE DEPARTMENT

TERMINATION TYPE	NUMBER
Death	1
Resignation	18
Expiry of contract	0
Dismissal (operational changes)	0
Dismissal (misconduct)	0
Dismissal (inefficiency)	0
Dismissal due to ill health	2
Retirement	10
Other (transfer out of Persal)	1

DESIGNATION	SALARY LEVEL	WHITE		COLOURED		INDIAN		AFRICAN		DISABILITY		SUBTOTAL		TOTAL
		M	F	M	F	M	F	M	F	M	F	M	F	
Director-General	16	1										1		1
Deputy Director-General	15							1	1			1	1	2
Chief Director	14	2			1			1				3	1	4
Director	13	4		1				4	3			9	3	12
Deputy Director/Chief State Herald/ Legal Administration Officer	11 - 12	12	9		1	1	1	11	6			24	17	41
Assistant Director/ Chief Training Officer/ Chief Work Study Officer/ Control Industrial Technician/ Chief Language Practitioner/ Principal State Herald/ Principal Planner/ Chief Planner/ Principal Techno-Economist/ Control Personnel Officer	9 - 10	9	20	2	2		2	8	10			19	34	53
Senior Personnel Practitioner/ Chief Personnel Officer/ Senior Provisioning Administration Officer/ Senior Security Administration Officer/ Senior State Accountant/ Senior Administrative Officer/ Principal Archivist/ Principal Communication Officer/ Principal Cultural Officer/ Chief Industrial Technician/ Principal Language Practitioner/ Principal Librarian/ Senior State Herald/ Chief Programmer/ Chief Network Controller/ Senior Planner/ Senior Techno-Economist	8	12	43	1	2	2	2	9	9		1	24	56	80
Chief: Data Capturing/ Personnel Practitioner/ Principal Personnel Officer/ Provisioning Administration Officer/ Chief Provisioning Administration Clerk/ Chief Accounting Clerk/ State Accountant/ Chief Registry Clerk/ Security Administration Officer/ Training Officer/ Chief Typist/ Work Study Officer/ Administrative Officer	7	3	7		3			10	6			13	16	29
Accounting Clerk/ Data Typist/ Typist/ Personnel Officer/ Provisioning Administration Clerk/ Secretary/ Telecom Operator/ Artisan/ General Foreman/ Administration Clerk/ Internal Auditor/ Archivist/ Communication Officer/ Language Practitioner/ Library Assistant/ Librarian/ Programmer/ Network Controller/ Auxiliary Services Officer/ Security Officer/ Principal Security Officer	2 - 6	14	46	13	10	1	2	53	46	2	2	81	104	185
Cleaner/ Driver/ Messaenger/ Operator/ Food Services Aid/ Ground Man/ Security Guard	1 - 2			4	2			23	20			27	22	49
SUBTOTAL		57	125	21	21	4	7	120	101	2	3	202	254	456
		182		42		11		221		5		456		
		39,9%		9,2%		2,4%		48,4%						

TABLE 4: Affirmative Action
TABLE 4.1: PROGRESS MADE WITH AFFIRMATIVE ACTION

Human Resources Management

Human Resources Management

TABLE 5: Performance Rewards

TABLE 5.1 - PERFORMANCE REWARDS BY RACE, GENDER AND DISABILITY

Beneficiary Profile			
	Number of beneficiaries	Number of employees	% of total
African			
Male	61	119	51,26
Female	43	100	43
Asian			
Male	2	4	50
Female	3	7	42,86
Coloured			
Male	8	21	38,09
Female	10	21	47,61
White			
Male	29	57	50,87
Female	77	125	61,6
Employees with a disability (included above)	3	5	60
TOTAL	233	454	51,32

Human Resources Management

TABLE 5.2 - PERFORMANCE REWARDS BY SALARY LEVEL

Salary Level	Beneficiary Profile		
	Number of beneficiaries	Number of employees	% of total
Levels 1 - 2	23	53	43,4
Levels 3 - 5	58	91	63,74
Levels 6 - 8	110	192	57,29
Levels 9 - 12	42	99	42,42
Total	233	435*	53,56

*Excluding the Senior Management Service.

Human Resources Management

TABLE 6: Skills Development

TABLE 6.1 - SKILLS DEVELOPMENT BY SALARY BAND AND TYPE OF TRAINING, 1 APRIL 2000 - 31 MARCH 2001

GRADE (SALARY BAND)	TYPE OF TRAINING	NUMBER OF BENEFICIARIES
Levels 1 - 2	ABET Seminar	25
	BATHO PELE	11
	ABET Training	24
Levels 3 - 5	1. Provisioning Administration 1	6
	2. PERSAL	5
	3. Archives	4
	4. Staff practices	2
	5. Secretaries	13
	6. Computer training	30
	7. Programmers	6
	8. Records management	3
	9. Language training General EnglishGerman	1 2
Levels 6 - 8	1. Performance management	4
	2. Provisioning Admin.	3
	3. Human Resources Management	17
	4. Job Evaluation training	4
	5. PERSAL	2
	6. Computer training	10
	7. Protocol	5
	8. Language training	2
	- German - French - Advanced FrenchOrientation	5 1 5
LEVELS 9 -12	1. Orientation	4
	2. People management	20
	3. Programme development	1
	4. Project management	3
	5. VULINDLELA training	1
	6. Disciplinary codes	1
	7. Change management	20
Senior Management Service	1. Leadership training	1
	2. Senior Executive Programme	1
	3. Financial management Systems	4
TOTAL		245

Human Resources Management

TABLE 6.2 - BURSARIES GRANTED BY SALARY LEVEL

Salary Level	Beneficiary Profile			Cost
	Number of beneficiaries	Number of employees	% of total	
Levels 1 - 2	2	53	3,77	R 4 750,00
Levels 3 - 5	39	91	42,86	R117 860,00
Levels 6 - 8	100	192	52,08	R349 661,00
Levels 9 - 12	20	99	20,2	R211 875,00
Professionals (13 - 14)	0	0	0	0
Senior Management Service	3	19	15,79	R 55 750,00
TOTAL	164	454	36,12	R739 896,00

Human Resources Management

TABLE 6.3 - BURSARIES GRANTED BY RACE, GENDER AND DISABILITY

	Beneficiary Profile			Cost
	Number of beneficiaries	Number of employees	% of total	
African				
Male	72	119	60,5	R306 890,00
Female	37	100	37,0	R201 808,00
Asian				
Male	4	4	100	R 21 975,00
Female	6	7	85,71	R 32 920,00
Coloured				
Male	1	21	4,76	R 5 280,00
Female	6	21	28,57	R 22 060,00
White				
Male	20	57	35,09	R 60 453,00
Female	18	125	14,4	R 88 510,00
Employees with a disability (included above)	3		5	60,0
TOTAL	164	454	36,12	R739 896,00

Financial Management

The main objective of the Directorate is to exercise control over state moneys and state assets as well as to implement systems which are conducive to economy, efficiency and effectiveness within the regulating and policy framework of the Public Finance Management Act, 1999 (PFMA), the Treasury Regulations the Preferential Procurement Policy Framework asct and the State Tender Board Act. The Directorate consists of the following main components:

FINANCIAL CONTROL

The Subdirectorate provides the Accounting Officer and programme managers with financial information and facilities, provides budgeting and expenditure information for management at a macro and micro level, as well as to the Treasury and Parliament. Furthermore, the Subdirectorate manages the Department's spending and monitors the outflow of funds from the Department and associated institutions and reports on it to Cabinet by means of the Early Warning System. During the course of 2000 this Subdirectorate took the appropriate steps to ensure the effective implementation of the PFMA.



*Mr Mike Rennie
Director:
Financial Management*

Financial Management

FINANCIAL ADMINISTRATION

The aim of the Subdirectorate is to provide effective and efficient financial administrative services to all officers in the Department. It also provides for their training needs in general financial administration. It ensures accurate funding reconciliation of all income and expenditure transactions and reports thereon for the financial year in compliance with the annual budget cycle. During the course of 2000 this Subdirectorate took the appropriate steps to ensure the effective implementation of the PFMA.

PROVISIONING ADMINISTRATION

The aim of the Provisioning Administration Subdirectorate is to procure goods and services for departmental officers, enabling them to carry out their tasks in a working environment appropriate to the level of their work.

The mission of the Subdirectorate is to promote the efficient, economic and effective use of material resources. To achieve this, it has complied with all mandatory prescripts issued by various control bodies, i.e. the Department of State Expenditure, the State Tender Board and the Auditor-General,

and other departmental directives issued from time to time.

The Subdirectorate acts as a facilitator for all officers, advising them on the acquisition of goods and services, obtaining tenders for goods and services through the Departmental Tender Committee, and approving the disposal or re-employment of movable state property (furniture, equipment and labour-saving devices) through the Disposal Board.

During 2000 the Subdirectorate translated from the Manual Provisioning Administration System to the LOGIS system. The appropriate steps were also taken to ensure the effective implementation of the PFMA.

INTERNAL AUDIT

During the past year the Internal Audit Component appointed an assistant director and established the Department's Audit Committee in terms of the PFMA and its related Treasury Regulations.

Internal Audit has been involved in various ad hoc investigations and conducted various regularity audits within the Department in terms of the Component's activity plan.

Financial Management

The Head: Internal Audit also acted as Loss Control Officer for the Department in this period and administrated all losses of and claims against the Department.

The Internal Audit Component was responsible for the coordination of the restructuring process at the State Theatre and also coordinated forensic investigations conducted at certain associated institutions of the Department as well as certain Legacy Projects.

LEGAL SERVICES

The following Bills were submitted to the Legislature during the report period:

- Cultural Laws Amendment Bill
- Cultural Laws Second Amendment Bill
- National Council for Library Information Services Bill

A number of Bills have been in the drafting process for submission to the Legislature:

- Repeal of the "Woordeboek van die Afrikaanse Taal" Act Bill

- Africa Institute of South Africa Bill
- Academy of Science of South Africa Bill
- Natural Scientific Professions Bill
- Institute for the Promotion of Science Bill
- South African Languages Bill
- South African Language Practitioners' Council Bill
- Cultural Industries Bill
- Innovation and Research Promotion Bill
- National Museums Bill
- Performing Arts Council Bill
- National Council for Innovation Amendment Bill
- Indigenous Knowledge Systems Bill
- Science Laws Amendment Bill

Audited Reports

NATIONAL DEPARTMENT: ARTS, CULTURE, SCIENCE AND TECHNOLOGY

REPUBLIC OF SOUTH AFRICA

ANNUAL FINANCIAL STATEMENTS: 31 MARCH 2001

CONTENTS	Page
Report of the Auditor-General	140 - 141
Report of the Audit Committee	142
Management Report and Approval	142 - 150
Statement of Accounting Policies and Related Matters	151 - 153
Income Statement (Statement of Financial Performance)	154 - 155
Notes to the Income Statement	156 - 159
Cash Flow Statement	160
Notes to the Cash Flow Statement	161
Balance Sheet (Statement of Financial Position)	162
Notes to the Balance Sheet	162-163
Statement of Foreign Aid Assistance	163

REPORT OF THE AUDITOR-GENERAL ON THE FINANCIAL STATEMENTS OF VOTE 4 - ARTS, CULTURE, SCIENCE AND TECHNOLOGY FOR THE YEAR ENDED 31 MARCH 2001

1. AUDIT ASSIGNMENT

The financial statements as set out on pages 154 to 163, for the year ended 31 March 2001, have been audited in terms of section 188 of the Constitution of the Republic of South Africa, 1996 (Act No. 108 of 1996), read with sections 3 and 5 of the Auditor-General Act, 1995 (Act No. 12 of 1995). These financial statements, the maintenance of effective control measures and compliance with relevant laws and regulations are the responsibility of the accounting officer. My responsibility is to express an opinion on these financial statements and the compliance with relevant laws and regulations, applicable to financial matters, based on the audit.

2. REGULARITY AUDIT

2.1 Nature and scope

2.1.1 Financial audit

The audit was conducted in accordance with generally accepted government auditing standards which incorporate generally accepted auditing standards. These standards require the audit to be planned and performed to obtain reasonable assurance that the financial statements are free of material misstatement. An audit includes:

- examining, on a test basis, evidence supporting the amounts and disclosures in the financial statements,
- assessing the accounting principles used and significant estimates made by management, and
- evaluating the overall financial statement presentation.

Due to the nature of the prescribed accounting practice, the audit was performed within a financial reporting framework which does not at this stage necessarily result in a fair presentation of the results of operations, financial position and cash flows for any financial period.

I believe that the audit provides a reasonable basis for my opinion.

2.1.2 Compliance audit

Furthermore, an audit includes an examination, on a test basis, of evidence supporting compliance in all material respects with the relevant laws and regulations which came to my attention and are applicable to financial matters.

I believe that the audit provides a reasonable basis for my opinion.

2.2 Audit opinion

2.2.1 Financial audit

In my opinion, the financial statements fairly present, in all material respects, the financial position of the department at 31 March 2001 and the results of its operations and cash flows for the year then ended in accordance with prescribed accounting practice and in the manner required by the relevant act.

2.2.2 Compliance audit

Based on the audit work performed, nothing has come to my attention that causes me to believe that material non-compliance with laws and regu-

lations, applicable to financial matters, has occurred.

3. EMPHASIS OF MATTER

Without qualifying the audit opinion expressed above, attention is drawn to the following matter:

3.1 Transfer payments

3.1.1 The State Theatre and Performing Arts Council of the Free State

In paragraphs 3.3.1 and 3.3.2 on page 3 of the previous report [RP 114/2000], it was mentioned that the above two institutions had incurred losses as a result of high-risk investments. The department indicated on 18 July 2001 that these matters were still being investigated by the special investigating unit.

4. APPRECIATION

The assistance rendered by the staff of the department during the audit is sincerely appreciated.



S A FAKIE

Auditor-General

Pretoria

26/07/2001

REPORT OF THE AUDIT COMMITTEE OF THE DEPARTMENT OF ARTS, CULTURE, SCIENCE AND TECHNOLOGY

This report has been prepared in terms of Treasury Regulation 3.1.10.

The Audit committee was appointed by the Executive Authority, Minister BS Ngubane on 8 December 2000. The Committee met for the first time on 20 February 2001 and subsequently on 5 June 2001.

The Committee consists of Messrs S Kajee (Chairman), RM Adam (Accounting Officer), P Benade, K Moloi and N Frick.

Persons in attendance include the Head of Internal audit and the (acting) Chief Financial Officer and representatives of the Office of the Auditor-General and National Treasury are invited.

The committee has reviewed the annual financial statements audited by the Office of the Auditor-General and is satisfied that these statements are reasonable and accurate.

The committee has also reviewed the reports of the Office of the Auditor-General and the internal audit department. In the context of

the committee's understanding of the risks facing the department, the committee is satisfied that the internal controls managing the major financial risks of the Department are effective.

MANAGEMENT REPORT: 31 MARCH 2001

1. General review of the state of financial affairs

Amount voted	R 969 303 000,00
Actual expenditure	R 948 386 477,98
Surplus	<u>R 20 916 522,02</u>

The net surplus relates to only 2,15% of actual expenditure against the voted funds for the 2000/2001 financial year. The majority of this underspending is in respect of Science and Technology projects which, due to unforeseen problems could not be paid out but where contractual agreements had already been finalised before the end of the financial year.

In order to improve financial management the Department during 1998/1999 established a component to explicitly manage its funds more

efficiently and effectively. The nett result has been that surpluses have significantly dropped since the 1998/99 financial year. The Department also established a Science and Technology co-ordination component in 1999/2000 in order to, amongst other issues enhance the management of funds done by the Directorate: Financial Management. A similar component was established in the Arts and Culture Branch at the end of the 2000/2001 financial year.

2. Services rendered by the Department:

2.1 National Archives

2.1.1 Type of service

The National Archives makes archival material available to the public which can be reproduced for further use. Although the actual availability of the archival documentation is free of charge the public is charged for reproducing the material. This reproduction entails film as well as paper reproduction. Publications are also sold and the public is charged for the transfer of data by means of magnetic medium.

2.1.2 Tariff policy

The tariffs are determined by the National Archivist taking into account the current

market rates. The tariffs are also approved by the National Treasury.

2.2 National Film-, Video and Sound Archives

2.2.1 Type of service

The National Film-Video and Sound Archives collects, preserves and provide access to audio-visual records created by both governmental and private bodies or private individuals. It aims to:

- * To preserve public and non-public audio-visual records, or documents, with enduring value, for use by the public and the State.
- * To make such records accessible and promote their use by the public.
- * To ensure the proper management and care of all public audio-visual records.
- * To collect non-public audio-visual and related records with enduring value of national significance, which cannot be more appropriately preserved by another institution.
- * To maintain national registers of non-public records with enduring value, and to promote cooperation and

coordination between institutions having custody of such records.

- * To generally promote the preservation and use of our national archival heritage.

2.2.2 Tariff policy

The tariffs are determined by the National Archivist taking into account the current market rates. The tariffs are also approved by the National Treasury.

2.3 Bureau for Heraldry

2.3.1 Type of service

Registration of heraldic representations, names special names and uniforms of associations and institutions. It also renders advice on heraldic and related matters and provides financial assistance to institutions, boards, committees or other public bodies or persons in order to promote the functional objectives of the Bureau of Heraldry.

2.3.2 Tariff policy

The tariffs are determined by the State

Herald in consultation with the National Archivist taking into account the current market rates. The tariffs are also approved by the National Treasury.

3. Public Entities

The following Public Entities were funded by the Department together with an indication of their allocation for the 2000/2001 financial year.

3.1 Declared cultural institutions: R119 301 999,40

The following institutions were declared as Cultural Institutions by the Minister of Arts, Culture, Science and Technology in terms of the Cultural Institutions Act of 1998. They must formulate policy to receive and preserve all property, of whatever kind, in their care, including specimens, collections or other movable property. They must also manage any movable property that belongs or has been given to Government by the people of South Africa.

• Northern Flagship Institution	R 23 551 416,04
• Southern Flagship Institution	R 24 263 000,00
• Natal Museum, Pietermaritzburg	R 4 909 000,00
• National Museum, Bloemfontein	R 9 691 000,00
• Die Afrikaanse Taalmuseum, Paarl	R 1 034 000,00
• The National English Literary Museum, Grahamstown	R 1 887 000,00
• Voortrekker Museum, Pietermaritzburg	R 3 575 912,18
• War Museum of the Boer Republics, Bloemfontein	R 2 204 000,00
• Robben Island Museum, Cape Town	R 21 238 000,00
• William Humphreys Art Gallery, Kimberley	R 1 432 000,00
• Nelson Mandela Museum, Umtata	R 2 000 000,00
• National Zoological Gardens of South Africa	R 10 809 000,00
• Foundation for Education, Science and Technology	R 7 597 000,00
• Freedom Park	R 4 936 671,18
• Voortrekker Monument	R 425 000,00
• 1820 Foundation	R 1 440 000,00
• Huguenot Monument	R 9 000,00
• Louis Trichardt Remembrance Garden	R 23 000,00
• Vegkop Battle Field	R 50 000,00
• Bien Donne Manor House	R 60 000,00

3.2 South African Heritage Resources Agency: R9 718 000

The South African Heritage Resources Agency was established in terms of the National Heritage Resources Act of 1999 to:

- Introduce an integrated and interactive system for the management of the national heritage resources
- Promote good government at all levels
- Empower civil society to conserve its heritage resources for future generations
- Lay down general principles for heritage resources management
- Introduce an integrated system for the identification, assessment and management of the heritage resources of South Africa
- Establish the South African Heritage Resources Agency, together with its Council, to coordinate and promote the management of heritage resources at national level
- Set norms and maintain essential national standards for the management of heritage resources in South Africa
- Protect heritage resources of national significance
- Control the export of nationally significant heritage object and the import into South Africa of cultural property illegally exported from foreign countries
- Enable the provinces to establish heritage authorities, which must adopt powers to protect and manage certain categories of heritage resources
- Provide for the protection and management of conservation-worthy places and areas by local authorities

3.3 Art institutions: R101 180 000

The arts institutions (establishment in terms of Section 21 of the Companies Act of 1973) assist in creating a sustainable performing arts industry based on access, excellence, diversity and redress. They encourage the development of the full range of performing arts. The institutions are:

- State Theatre R 31 891 000,00
- Playhouse Company R 21 060 000,00
- Cape Performing Arts Board R 21 920 000,00
- Provincial Arts Council of the Free State R 16 024 000,00
- Market Theatre R 8 000 000,00
- Wendybrow Theatre R 2 285 000,00

3.4 Business Arts South Africa: R2 000 000

Business Arts South Africa is a Section 21 Company aimed at encouraging sponsorship of the arts by the business and private

sector through the introduction of a matching grant scheme

3.5 National Film and Video Foundation: R8 330 066

In terms of the National Film and Video Foundation Act of 1997, the Foundation develops and promotes the film and video industry. It provides and encourages the provision of opportunities for persons from disadvantaged communities to participate in the industry. The Foundation also promotes local film and video products; supports the development of and access to the industry; and addresses historical imbalances in infrastructure, skills and resources in the industry.

3.6 National Arts Council: R23 200 000

In terms of the National Arts Council Act of 1997, the Council facilitates opportunities for people to practice and appreciate the arts. The Council also promotes the general application of the arts in the community, fosters the expression of a national identity by means of the arts, promotes freedom in the

practice of the arts, and gives historically disadvantaged people greater access to the arts. Other functions include addressing historical imbalances in the provision of infrastructure and promoting national and international liaison.

3.7 National Archives Commission

The National Archives Commission advises the Minister on any matter related to the National Archives Commission Act of 1996. The Commission also assists the National Archivist in carrying out the functions of the National Archives, promotes the coordination of archival policy at national and provincial levels, approves the appraisal policy of the National Archives and monitors its implementation. The Commission maintains a national list of non-public records in South Africa. The National Archives Commission did not have an approved budget for the 2000/2001 financial year and all expenditure relating to work done by the Commission was booked against

Programme 3: National Archives of South Africa.

3.8 Pan South African Language Board: R13 020 000

The Board actively promotes an awareness of multilingualism as a national resource, and supports the previously marginalised languages by developing, administering and monitoring access, information and implementation programmes. These activities are in accordance with the provisions of the Pan South African Language Board Act of 1999.

3.9 Woordeboek van die Afrikaanse Taal: R2 017 000

A Bureau for the Woordeboek van die Afrikaanse Taal was established in terms of Act 50 of 1973.

- the continuous and comprehensive collecting, arranging and storing in a lexicographically workable form, of the vocabulary of the Afrikaans language;

- the editing of the collected material according to lexicographical principles in the form of a dictionary of definitions in consecutive parts; and
- granting access to the language material and sources of the bureau to researchers according to the policy of the board.

3.10 General Dictionary Unit of South African English: R610 000

The Dictionary Unit of South African English is a Section 21 Company which objectives are in line with that of the "Woordeboek van die Afrikaanse Taal" but for the English language.

3.11 Human Sciences Research Council: R61 452 000

The Council provides for the promotion of research and the extension of knowledge in the field of the human sciences in terms of the Human Sciences Research Council Act of 1968.

3.12 National Research Foundation: R272 884 000

The Foundation provides for the promotion of

research, both basic and applied, and the extension and transfer of knowledge in the field of sciences, technology and indigenous technology, in terms of the National Research Foundation Act of 1998.

3.13 Council for the Africa Institute of South Africa: R7 351 000

The Council is a Section 21 Company that carries out in-depth analysis of Africa's current affairs and addresses issues of the future of the continent the African Renaissance and change in general.

3.14 Libraries: R21 228 000

Libraries preserve and promote awareness of the national documentary heritage, and provide for matters connected therewith. They include the South African Library for the Blind, which provides library and information services to blind and print-handicapped readers, and for matters connected therewith. The institutions are:

- National Library R 17 621 000,00
- South African
Library for
the Blind R 3 041 000,00
- South African
Blind Worker's
Organisation
(Section 21
company) R 566 000,00

4. Risk management and fraud prevention:

The Department of Arts, Culture, Science and Technology has invited tenders for a consultant to conduct a risk assessment for the department and to develop a fraud prevention plan. The tender will be awarded in August 2001.

The risk assessment will form the basis of the Department's three year strategic internal audit plan which in turn will be used to compile the annual internal audit plan. It will be the responsibility of DACST's internal audit component to ensure that the identified risks

are properly addressed by management. This will be accomplished by using departmental resources and/or consultants.

The Department's fraud prevention plan will form part of the DACST fraud strategy which will include prevention, detection and action. As an attachment to the fraud prevention plan the Department will also establish a hotline in 2001/2002 as another preventative measure to combat fraud and corruption.

The attached financial statements set out in pages 154 to 163 have been approved by



DR R M ADAM
DIRECTOR-GENERAL (ACCOUNTING OFFICER)
DATE: 31/07/01

STATEMENT OF ACCOUNTING POLICIES AND RELATED MATTERS: 31 MARCH 2001

1 Basis of accounting

The financial statements have been, unless otherwise indicated, prepared on the historical cost basis in accordance with the under mentioned policies which have been applied consistently in all material respects.

1.1 Underlying assumptions

The financial statements have been prepared on the cash basis of accounting except where stated otherwise. Under the cash basis of accounting transactions and other events are recognised when cash is received or paid. This basis of accounting measures financial results for a period as the difference between cash receipts and cash payments. Reliance is placed upon the fact that the Department is a going concern.

However, where appropriate and meaningful, additional information has been disclosed to enhance the usefulness of the financial statements and to comply with the

statutory requirements of the Public Finance Management Act, Act 1 of 1999 (as amended by Act 29 of 1999) and the Treasury Regulations for Departments and Constitutional Institutions issued in terms of the Act.

1.2 Revenue

Revenue of the State and/or departmental receipts are paid over to the principal receivers of revenue. Unexpended voted funds are surrendered to the National Revenue Fund.

1.3 Expenditure

The income statement includes both current and capital expenditure. Unauthorised expenditure is not accounted for as expenditure until such expenditure is either authorised by Parliament, recovered from a third party, or funded from the following year's appropriation.

1.4 Assets

Physical assets (fixed assets, moveable assets and inventories) are written off in full

when they are paid for and are accounted for as expenditure in the Income Statement. The Balance Sheet therefore excludes physical assets unless stated otherwise.

1.5 Receivables and payables

Receivables and payables are not normally recognised under the cash basis of accounting. However, receivables and payables included in the balance sheet arise from cash payments which are recoverable and cash receipts which are due to either the National Revenue Fund or another party.

2 Comparative figures

The comparative figures shown in these financial statements are limited to the figures shown in the previous year's audited financial statements and such other comparative figures that the department may reasonably have available for reporting in terms of the Public Finance Management Act.

3 Unauthorised, irregular, and fruitless and wasteful expenditure

Unauthorised, irregular, and fruitless and

wasteful expenditure is treated as a current asset in the balance sheet until such expenditure is either recovered, authorised by Parliament, or set off against future voted funds.

4 Debt write-off policy

The Department only writes off debts after the official responsible for authorising the writing off of a particular debt as determined in the Department's financial delegations has convinced herself/himself that the debt is irrecoverable owing to the following:

Amounts exceeding R10 000

- the debtor having neither assets nor income, or
- all reasonable efforts to trace the debtor have failed, or
- the State's claim is against an insolvent estate or an estate that is being administered as insolvent, having been proved properly and in good time and the dividend of the creditors being insufficient to meet the debt, or
- the Accounting Officer is satisfied that on account of the weak

financial position of an estate, the danger exists that if the debt is proved a contribution will have to be paid to the estate (where there is any doubt, the State Attorney should be consulted) and

- there is no possibility now or in the foreseeable future of collection; or
- the debtor is no longer a resident in South Africa, and there are no apparent means of collecting the debt and there is no evidence that the debtor has a family or business concerns in South Africa that could lead to the debtor returning to South Africa; or
- the evidence of the debt has been lost or destroyed and the debtor denies that a debt exists; or
- the debtor is deceased and there is no known estate

Amounts not exceeding R10 000

- the recovery of the debt would be uneconomical; or
- the recovery of the debt would cause undue hardship to the debtor or the debtor's dependants because they would be deprived of the minimum essential means of livelihood; or

- the assets of the debtor or of the estate of the debtor are indispensable to the debtor's dependents or are of relatively little value; or
- it would be to the advantage of the State to effect a settlement of its claim or to waive such claim.

The Department does not write off debts owed by its employees or cases of debt that originated or became irrecoverable owing to fraud, theft, willful damage, negligence or delay on the part of any of its employees.

The Department's financial delegations provide for the writing off of debt to the following positions within the Department:

Director-General	: Debts in excess of R30 000
Chief Financial Officer	: Debts up to R30 000
Director Financial Management	: Debts up to R10 000

The Department has written off debt to the amount of R2 827,53 during the 2000/01 financial year according to the above-mentioned principles.

Income Statement

INCOME STATEMENT (Statement of Financial Performance)
for the year ended 31 MARCH 2001
(all figures R 000)

Previous Year R 000 Actual	INCOME	Note	Current year		
			R 000 Actual	Voted amount	Variance Over/(under) collection
845 103	Voted funds		966 444	969 303	(2 859)
567	Other receipts	1	643		643
<u>845 670</u>			<u>967 087</u>	<u>969 303</u>	<u>(2 216)</u>
			Actual	Voted amount	Variance Over/(under) expenditure
835 810	EXPENSES		948 387	969 303	20 916
<u>9 860</u>	NET SURPLUS/ (DEFICIT) FOR THE YEAR		<u>18 700</u>	<u>18 700</u>	<u>18 700</u>
			Actual		
567	Income transferable to Revenue Fund	2	643		
9 293	Voted funds to be surrendered to Revenue Fund/(Deficit)		18 057		
<u>9 860</u>			<u>18 700</u>		

Income Statement

EXPENSES PER PROGRAMME		3	Actual	Voted amount	Variance Over/(under) expenditure
25 377	Programme 1: Administration		30 466	28 378	(2 088)
295 033	Programme 2: Arts and Culture		303 290	303 450	160
17 241	Programme 3: National Archives of South Africa		18 178	18 895	717
25 695	Programme 4: National Language Services		26 380	27 319	939
472 464	Programme 5: Science, Technology and Meta-Information		570 073	591 261	21 188
<u>835 810</u>			<u>948 387</u>	<u>969 303</u>	<u>20 916</u>
EXPENSES PER STANDARD ITEM			Actual		
50 690	Personnel expenditure		54 628	57 159	2 531
16 925	Administrative expenditure		20 292	16 553	(3 739)
2 384	Inventory		2 741	3 178	437
3 999	Equipment	4	3 392	4 109	717
11 013	Professional and special services	5	12 166	11 990	(176)
749 949	Transfer payments	6	854 633	875 163	20 530
850	Miscellaneous	7	535	1 151	616
<u>835 810</u>			<u>948 387</u>	<u>969 303</u>	<u>20 916</u>
Previous year R 000 actual	ECONOMIC CLASIFICATION OF EXPENDITURE		Current year R 000 actual	Current year % of total	
453	Capital expenditure		1 407	0.1%	
85 408	Current expenditure		92 347	9.7%	
1 208	Capital transfers		1 208	0.1%	
748 741	Current transfers		853 425	90.0%	
<u>835 810</u>			<u>948 387</u>	<u>100%</u>	
PRIOR YEAR EXPENDITURE ALLOWED DURING CURRENT YEAR					
Previous year	Reason(s) why previously disallowed	Nature of expenditure	Amount		
-	The Standing Committee on Public Accounts has not made a decision that the unauthorised expenditure in respect of the guards of the former Deputy Minister, Mrs NW Madikizela-Mandela be authorised. This amount has been authorised in the Finance Act, 2000	Travel and subsistence expenditure	109		
<u>-</u>			<u>109</u>		

Notes to the income statement

NOTES TO THE INCOME STATEMENT for the year ended 31 MARCH 2001 (all figures R 000)

1 Other receipts

Description	Actual Estimate	Adjusted Over/ (under) collected	Variance
Gifts, donations and sponsorships received	20	-	20
Other			
Stale cheques written to income	31	-	31
Recoverable revenue received	61	-	61
Repayment on loans in respect of the Subsidised Motor Vehicle Scheme	23	-	23
Commission	43	-	43
Previous year expenditure recovered	165	-	165
Services rendered - National Archives of South Africa	209	-	209
Unspecified miscellaneous expenditure	91	-	91
Total	643	-	643

2 Income transferable to Revenue Fund

Description	Actual
Transfers i.r.o. previous year	38
Transfers i.r.o. current year	609
Current year transfers outstanding	34
Total [To agree with Income Statement]	643

3 Expenses per programme and explanation of material differences

	Actual	Voted	Variance
Programme 1: Administration	30 466	28 378	(2 088)
Sub programme: Minister	730	518	(212)
Sub programme: Deputy Minister	571	421	(150)
Sub programme: Management	3 588	3 349	(239)
Sub programme: Corporate services	25 577	24 024	(1 553)
Sub programme: Government motor transport	-	66	66
Programme 2: Arts and Culture	303 290	303 450	160
Sub programme: Arts, cultural and heritage institutions	113 703	113 703	-
Sub programme: Conservation bodies	9 718	9 718	-
Sub programme: Promotion of arts and culture in the RSA	138 063	144 564	6 501
Sub programme: Foundations, councils and associations for arts and culture	23 200	23 200	-
Sub programme: Administration	18 606	12 265	(6 341)
Programme 3: National Archives of South Africa	18 178	18 895	717
Sub programme: National archives	16 974	17 881	907
Sub programme: National Archives Commission	256	-	(256)
Sub programme: Bureau of Heraldry	948	1 014	66
Programme 4: National Language Services	26 380	27 319	939
Sub programme: Translating, editing and planning	6 455	6 960	505
Sub programme: National terminology	5 236	5 394	158
Sub programme: Pan South African Language Board	13 020	13 020	-
Sub programme: South African Geographical Names Council	159	400	241
Sub programme: Administration	1 510	1 545	35

Notes to the income statement

Programme 5: Science, Technology and Meta-Information	570 073	591 261	21 188
Sub programme: Science, technology and knowledge system development and maintenance	169 906	188 278	18 372
Sub programme: Technology development	13 353	19 534	6 181
Sub programme: Science and society	5 290	10 752	5 462
Sub programme: Support for institutions active in science, technology and information service activities	370 472	370 472	-
Sub programme: Administrative support services	11 052	2 225	(8 827)

Explanation of material differences

Programme 1: Administration

Excess due to the increased travel cost of the Minister and Deputy Minister. Their portfolio covers a broad range of activities, which includes Arts and Culture, Science & Technology, Language, Archives and Heraldry. Increasingly these areas are seen as primary drivers of economic development and quality of life. The Minister has been invited to participate in a number of these cluster structures in Government. These clusters include Economic Affairs and Employment, Social Sector, International Affairs and Investment and Employment.

Programme 2: Arts and Culture

Saving due mainly to vacancies not filled which, will be utilised for the excess at Programme 1: Administration

Programme 3: National Archives of South Africa

Saving due mainly to vacancies not filled which, will be utilised for the excess at Programme 1: Administration

Programme 4: National Language Services

Saving due mainly to vacancies not filled which, will be utilised for the excess at Programme 1: Administration

Programme 5: Science, Technology and Meta-Information

Saving due mainly to funds provided for projects such as the Lead projects, Technology Incubators and Innovation Fund which, will be rolled over to 2001/2002 financial year

4 Equipment

Description	Actual
Current (Rentals, maintenance and sundry)	1 985
Capital	1 407
Totals	<u>3 392</u>

5 Professional and special services

Description	Actual
Auditors' remuneration	387
Contractors	2 672
Consultants and advisory services	5 570
Other	3 537
Totals	<u>12 166</u>

6 Transfer payments

Transferee	Purpose	Actual	Adjusted Estimate	Variance Under/ (over) expenditure
Northern Flagship Institution	Current subsidy	23 551	24 598	1 047
Southern Flagship Institution	Current subsidy	24 263	24 263	-
Natal Museum, Pietermaritzburg	Current subsidy	4 909	4 909	-
National Museum, Bloemfontein	Current subsidy	9 691	9 691	-
Die Afrikaanse Taalmuseum, Paarl	Current subsidy	1 034	1 034	-
The National English Literary Museum, Grahamstown	Current subsidy	1 887	1 887	-
Voortrekker Museum, Pietermaritzburg	Current subsidy	3 576	3 466	(110)

Notes to the income statement

War Museum of the Boer Republics, Bloemfontein	Current subsidy	2 204	2 204	-
Robben Island Museum, Cape Town	Current subsidy	21 238	21 238	-
William Humphreys Art Gallery, Kimberley	Current subsidy	1 432	1 432	-
Engelenburg House Art Collection, Pretoria	Current subsidy	84	84	-
Nelson Mandela Museum, Umtata	Current subsidy	2 000	2 000	-
Constitutional Hill: Johannesburg	Current subsidy		500	500
Albert Luthuli Project	Current subsidy		500	500
Khoi-San Project	Current subsidy		2 000	2 000
Freedom Park: Pretoria	Current subsidy	4 937	1 000	(3 937)
Voortrekker Monument: Pretoria	Current subsidy	425	425	-
1820 Foundation: Grahamstad	Current subsidy	1 440	1 440	-
Huguenot Monument: Franschhoek	Current subsidy	90	90	-
Louis Trichardt Remembrance Garden : Maputo	Current subsidy	23	23	-
Vegkop battle field: Heilbron	Current subsidy	50	50	-
Bien Donne Manor House: Franschhoek	Current subsidy	60	60	-
National Zoological Gardens of South Africa: Pretoria	Current subsidy	10 809	10 809	-
South African Heritage Resources Agency	Current subsidy	9 718	9 718	-
State Theatre	Current subsidy	31 891	31 891	-
Playhouse Company	Current subsidy	21 060	21 060	-
Cape Performing Arts Board	Current subsidy	21 920	21 920	-
Performing Arts Centre of the Free State	Current subsidy	16 024	16 024	-
Market Theatre	Current subsidy	8 000	8 000	-
Windybrow Theatre	Current subsidy	2 285	2 050	(235)
Business Arts South Africa	Current subsidy	2 000	2 000	-
National Film and Video Foundation	Current subsidy	8 330	6 511	(1 819)
National Arts Council	Current subsidy	23 200	23 200	-
Financial assistance projects: Promote arts and culture in the RSA	Current subsidy	6 883	6 451	(432)
Financial assistance projects: Promote arts and culture internationally	Grant-in-aid	2 897	2 800	(97)
Financial assistance projects: Promote the film industry in the RSA	Grant-in-aid	2 452	4 471	2 019
Financial assistance projects: Promote heritage in the RSA	Grant-in-aid	1 102	1 417	315
RDP Project: Stabilisation of the Youth	Grant-in-aid	1 884	2 406	522
Poverty relief: Culture and development group of projects	Grant-in-aid	11 335	12 000	665
National Archives Commission	Grant-in-aid	-	-	-
National Archives: Financial assistance projects	Current subsidy	-	1	1
Pan South African Language Board	Grant-in-aid	13 020	13 020	-
Woordeboek van die Afrikaanse Taal (WAT)	Current subsidy	2 017	2 017	-
General Dictionary Unit for SA English	Current subsidy	610	610	-
Financial assistance projects: Promotion of Language	Current subsidy	220	260	40
Human Sciences Research Council	Grant-in-aid	61 452	61 452	-
National Research Foundation (Current expenditure)	Current subsidy	272 844	272 844	-
Council for the Africa Institute of South Africa	Current subsidy	7 351	7 351	-
Foundation for Education, Science and Technology	Current subsidy	7 597	7 597	-
National Library	Current subsidy	17 621	17 621	-
South African Library for the Blind	Current subsidy	3 041	3 041	-
South African Blind Worker's Organisation (Section 21 company)	Current subsidy	566	566	-
Innovation Fund	Current subsidy	113 320	119 000	5 680
Financial assistance projects: Science, technology and knowledge systemdevelopment and maintenance:	Grant-in-aid	35 958	42 100	6 142
Poverty Relief: Agricultural Processing Group	Grant-in-aid	18 000	18 000	-
Technology development: Financial assistance project	Grant-in-aid	11 630	15 378	3 748
Science and society: Financial assistance projects	Grant-in-aid	4 702	8 683	3 981
Totals		854 633	875 163	20 530

Notes to the income statement

6.1 Report of written assurance obtained from entities regarding the implementation of effective, efficient and transparent financial management and internal control systems in terms of Section 38(1)(j) of the Public Finance Management Act

The Department has requested the information from its institutions and has received some returns in this regard. The institutions are being funded for a number of years and effective, efficient and transparent financial management and internal control systems do exist at the institutions. The Department also received the new Treasury Regulations with regard to Public Entities and will obtain the outstanding information as requested in

Section 38(1)(j) of the Public Finance Management Act during the 2001/02 financial year.

7. Miscellaneous

Description	Actual
Stabilisation fund	351
Other losses written off	108
Debts written off	3
Gifts, donations and sponsorships made	66
Other	7
Totals	<u>535</u>

7.1 Gifts, donations and sponsorships paid in cash

Paid to	Purpose	Amount
Estate of late MS Velalo	Contribution to funeral expenses	10
William Komla Amoako	Contribution towards the work done by Prof WK Amoako on the Music Industry Task Team	5
Ray Ntlokwana benefit fund	Contribution to funeral expenses	10
Estate of late BR Hermanus	Contribution to funeral expenses	10
Estate of late Wendy Mseleku	Contribution to funeral expenses	10
Estate of late BG Dube	Condolence to Dube family	1
Estate of late M Maseko	Contribution to funeral expenses	4
Totals		<u>50</u>

7.2 Gifts, donations and sponsorships made in kind

Made to	Purpose	Value
The Department presented numerous gifts to various foreign and local dignitaries during official visits and other functions. These gifts consisted of local books, CD's artifacts and crafts. In the majority of cases these gifts have a monetary value of less than R100,00 and is thus not practical and in certain cases not possible due to the fact that the recipients are unknown to list all the gifts presented during the financial year	It is customary to exchange/present gifts during official visits and other functions. This not only promotes the Department, but also South Africa in general as all gifts that are presented are of local content	16
Totals		<u>16</u>

Cash Flow Statement

CASH FLOW STATEMENT
for the year ended 31 MARCH 2001
 (all figures R 000)

CASH FLOWS FROM OPERATING ACTIVITIES	Note	R 000
Net cash flow from operating activities excluding capital items	1	20 107
CASH FLOW FROM INVESTING ACTIVITIES		(1 407)
Purchase of plant and equipment		(1 407)
Net cash flows from operating and investing activities		18 700
CASH FLOWS FROM FINANCING ACTIVITIES		(2 881)
Movements on receivables, prepayments, advances, payables and provisions	2	(2 881)
Net increase/(decrease) in cash and cash equivalents		15 819
Cash and cash equivalents at beginning of period	3	423
Cash and cash equivalents at end of period	4	16 242

Notes to the Cash Flow Statement

NOTES TO THE CASH FLOW STATEMENT

for the year ended 31 MARCH 2001

(all figures R 000)

	2000/2001
1. Net cash flow from operating activities excluding capital items	
Net surplus as per Income Statement	18 700
Deduct from net surplus:	
Proceeds from sale of capital items	<u>18 700</u>
Add to net surplus:	
Purchase of capital items	1 407
Net cash flow from operating activities excluding capital items	<u><u>20 107</u></u>
2. Movement on receivables, prepayments, advances, payables and provisions	
Finance required to increase receivables/decrease payables	(16 934)
Finance generated by increases payables/decreases receivables	14 053
Net funds required to finance receivables and payables/or Net funds generated by receivables and payables	<u><u>(2 881)</u></u>
3. Cash and cash equivalents beginning of period	
Paymaster general account	411
Cash on hand	<u>12</u>
Total	<u><u>423</u></u>
4. Cash and cash equivalents end of period	
Paymaster general account	16229
Cash on hand	<u>13</u>
Total	<u><u>16 242</u></u>

Balance Sheet at 31 March 2001

BALANCE SHEET: (Statement of Financial Position)
at 31 MARCH 2001
(all figures R 000)

Previous year R 000		Current year R 000
15 556	ASSETS	
	Current assets	33 147
109	Unauthorised, irregular, and fruitless and wasteful expenditure	-
423	Cash and cash equivalents	16 242
13 753	Receivables	15 476
1 229	Prepayments and advances	1 406
42	Loans	23
15 556	Total assets	33 147
	LIABILITIES	
15 556	Current liabilities	33 147
38	Revenue to be surrendered	34
9 293	Voted funds to be surrendered	18 058
6 225	Payables	15 055
15 556	Total Liabilities	33 147

NOTES TO THE BALANCE SHEET
at 31 MARCH 2001 (all figures R 000)

1. Cash and cash equivalents

Description	Amount
Paymaster General Account	16 229
Cash with commercial banks	
Cash in transit	
Cash on hand	13
Short-term investments	
Total	16 242
1.1 Paymaster General Account	
Balance as per National Accounting Office	19 811
Add: Outstanding deposits	1 149
PMG adjustment account	324
EBT control account	
Sub total	21 284
Deduct:	
Claims payable: National Treasury	
Orders payable	5 019
PMG adjustment account	
Electronic funds payable	

ACB control account		31	
EBT control account		5	
Balance above		<u>16 229</u>	
2. Receivables - current			
Description		Amount	
Staff debts		751	
Other loans and debts		<u>14 725</u>	
Total		<u>15 476</u>	
2.1 Age analysis			
Less than one year		(2 444)	
One to two years		(3 535)	
More than two years		<u>21 455</u>	
Total		<u>15 476</u>	
3. Prepayment and advances			
Nature of prepayments/advances			
Persal salaries and stoppages		176	
Advances paid to departments for the rendering of services		135	
Travel and subsistence advances issued to officials		<u>1 095</u>	
Total		<u>1406</u>	
4. Loans			
Description	Purpose		Amount
Granted to C. Hoch			
	Purchase of subsidised vehicle under old Subsidised Motor Vehicle Scheme		
Total			<u>23</u>
5. Payables - current			
Description			Amount
Persal salaries and stoppages			47
Outstanding income in respect of interest bearable debt owed to the South African Revenue Services			303
Electronic Banking transfers to still to be debited against PMG Account.			<u>14 705</u>
Total			<u>15 055</u>
6. Contingent liabilities			
Liable to	Nature of contingent liability		
Various banking institutions	Housing guarantees		1 790
Stannic	Motor vehicle finance scheme guarantees		<u>591</u>
Total			<u>2,381</u>

PENDING APPLICATIONS FOR ASSISTANCE		
Source of assistance	Intended use	Amount
European Union	Technology Incubators	35 000
Total		35 000

Minister

Dr Ben Ngubane (012) 337-8373

Deputy Minister

Ms Brigitte Mabandla (012) 337-8334

Director-General

Dr Rob Adam (012) 337-8297

CORPORATE SERVICES

Deputy Director-General: Corporate Services

Mr Peter Pedlar (012) 337-8000

Chief Director: Corporate Communication Unit

Mr Andile Xaba (012) 337-8497

Director: Human Resources Management

Ms Nobubele Ngele (012) 337-8408

Director: Financial Management

Mr Mike Rennie (012) 337-8236

SCIENCE AND TECHNOLOGY BRANCH

Deputy Director-General: Science and Technology

Vacant

Chief Director: Research and Technology Development

Ms Marjorie Pyoos (012) 337-8221

Chief Director:S&T Cooperation and Promotion

Dr Bothale Tema (012) 337-8008

Director: Bilateral Science and Technology Cooperation

Dr Chris Scheffer (012) 337-8142

Director: Branch Coordinator

Mr Arno Webb (012) 337-8357

Director: Multilateral Science & Technology Cooperation

Dr Neville Arendse (012) 337-8292

Director: Science and Society

Ms Kebogile Dilotsotlhe (012) 337-8370

Director: Science Budget Planning and Management

Vacant

Director: Research and Technology Development

Dr Joseph Matjila (012) 337-8467

ARTS AND CULTURE BRANCH

Deputy Director-General: Arts and Culture

Mr Themba Wakashe (012) 337-8275

Chief Director: Arts and Culture Branch Coordination

Mr Frans Basson (012) 337-8283

Director: Arts Institutional Governance

Mr Sydney Selepe (012) 337-8006

Director: Arts and Culture International Liaison

Mr Victor Julius (012) 337-8130

Director: Cultural Development

Mr Steven Sack (012) 337-8371

Director: Heritage

Mr Vusithemba Ndima (012) 337-8032

Chief Director: National Archives

Dr Graham Dominy (012) 323 5300

Director: National Archives

Ms Mandy Gilder (012) 323 5300

Director: National Language Service

Dr Nonhlanhla Mkhulisi (012) 337-8081

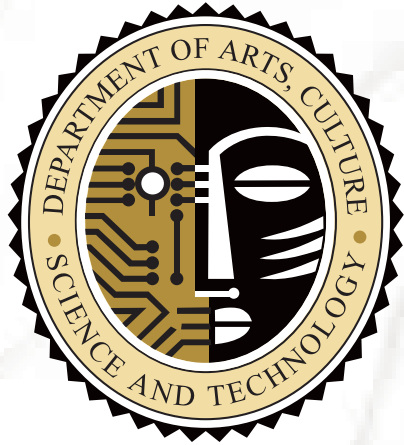

ISBN 0-7970-3934-1