

Thomasville

F L O O R I N G®

Engineered Hardwood Flooring

Installation, Care and Warranty Guide

Warranty coverage may be lost due to failure to strictly abide by all the installation instructions and recommendations in this manual. This includes the use of improper tools and materials.

Read all instructions carefully.

Part I INSTALLATION AND CARE

Product Description

Thomasville engineered hardwood flooring planks are designed for use in multiple locations, such as basements, ground floors or high-rise buildings; whether floating on or directly glued to a concrete sub-floor or direct nailing or gluing to wooden sub-floors. The multi-ply engineered flooring is made of a 5/64" (2.2 mm) wear layer of solid wood lamella mounted under high pressure to produce premium quality flooring. The products are pre-finished under ideal conditions that meet or exceed industry standards.

Recommended Use

Grade Type	Nail Down	Glue Down	Float
Above Grade	Yes	Yes	Yes
On Grade	Yes	Yes	Yes
Below Grade	No	No	Yes



Sub-floor Type	Nail Down	Glue Down	Floating
Concrete	No	Yes	Yes
Plywood & OSB*	Yes	Yes	Yes
Old wooden floor, particleboard, pressed board & other non-wood sub-floor	No	No	Yes

* As defined by NWFA Hardwood Flooring Installation Guidelines-Section V for moisture testing. Concrete moisture readings: Not to exceed 4.5% on Tramex Concrete Moisture Encounter meter. Calcium Chloride Test: Not to exceed 3 lbs. per 1000 square feet in 24 hours.

** Plywood must be CDX-rated at least 3/4" thick. OSB must be 3/4", PS2 rated, sealed side down.

Radiant Heating

- Prior to installation, radiant heat system must have been tested and in operation for a few weeks.
- Do not raise or lower temperature of subfloor radiant heat system by more than 5°F per day when turning system on and off. The wood surface temperature must never exceed 80°F.
- The heating system must be buried in concrete.
- Glue down installation is the ONLY recommended method over radiant heat.

How Much Flooring to Order

Depending on the location and installation type, order 5% to 10% more flooring than needed to compensate for cutting losses.

IMPORTANT: Examine each plank carefully. Contact the dealer immediately if the material is not acceptable. Materials installed with visible defects are not covered under warranty. Manufacturer will not assume any responsibility for installed materials. Product liability will not be implemented for damages caused by unsuitable tools or the improper use of materials.

Crucial Points to Remember

1. Installation should not be started until the wood has been at the jobsite for at least 4 days, but materials should be allowed to acclimate for as long as necessary to meet minimum installation requirements for moisture content in your area.
2. Install your floor under good lighting conditions. Installation site should be warmed up for 5 to 6 days before wood delivery regardless of the season to remove residual moisture in the sub-floor. The floor surface must never be warmer than 85⁰F (29.5⁰C) or colder than 50⁰F (10⁰C) during or after installation.
3. Plan your project by making an installation sketch. Determine the installation starting point. Consider if it is one regular-shaped room, a number of rooms with landings, or rooms on one floor, including a hall or main room. Think about how to get the most out of your pocket. If in doubt, ask your dealer for advice.
4. Choose the floor plank direction. It is strongly recommended that you install boards at a 45⁰ or 90⁰ angle to the joist direction. Not applicable for installation on concrete.
5. Take precautions at all times not to damage the finish. For example, place tools on a protective mat during installation. Vacuum or sweep floor frequently to eliminate sawdust and abrasives. Do not use vacuums with beater bars or hard plastic attachments.
6. Before starting installation, cut the bottom moldings around door frames to insert the floor planks underneath. Expansion joint is necessary to allow the wood to react to changes in ambient humidity. The expansion joint will be hidden by wood flooring moldings, such as T-molding, quarter round, etc., which will be nailed to the walls and not the floor.

Jobsite Preparation

Laying the floor should be the last step of your installation. Prior to the delivery of your flooring, make sure that:

- The jobsite is properly enclosed, with all doors and windows installed.
- Concrete, plaster, paint and the sub-floor are completely dry.
- The heating or ventilation system is working properly and that the conditions inside your home have been kept at an approximate temperature of 60-70⁰F (20⁰C) and a relative humidity of 35% to 50% for at least two weeks.
- The floor of the crawl space (if there is one) is completely covered by 6-8 mil black polyethylene film and has adequate cross ventilation.

Wood Sub-floor

The sub-floor (plywood or OSB) moisture content should be between 6-10%, but not exceed 12%, and the difference in moisture between the sub-floor and floor planks should not be greater than 4% of the floor planks. If the difference is too high, do not carry out installation. Please refer to the Equilibrium Moisture Content of Wood Map to determine acceptable moisture levels for your area. Wooden sub-floors must be securely screwed down to joists to prevent any movements or squeaks. Inspect existing subfloor and replace subfloor that exhibits signs of water damage or structural weakness.

Concrete Sub-floor

For concrete sub-floors, a minimum of 45 days drying time for a reliable moisture reading is necessary. As defined by NWFA, moisture readings must not exceed 4.5% with a moisture meter for concrete (Tramex Moisture Encounter). In the presence of moisture, perform a calcium chloride test. The moisture level measured using the calcium chloride test must not exceed 3 lb/1,000 sq. ft./24 hours. If the reading exceeds 3 lb. but is below 7 lb., install a waterproof membrane, such as Bostik MVP or equivalent.

IMPORTANT: When it comes to floor installation, moisture is an important element that should be emphasized. The installer and homeowner are jointly responsible for checking the sub-floor moisture content. If the moisture content is too high,

postpone floor installation. Never install a hardwood floor on concrete if the calcium chloride moisture test reading exceeds 7 lb/1,000 sq.ft./24 hours, or on wood sub-floor if moisture test reading exceeds 12%. Any responsibility for failures or deficiencies related to job site quality is declined by the manufacturer.

Installation Work

Once ambient conditions are correct, bring the cases of floor planks to the installation site. Open a case to check that product species, grade, color, size, and quality are correct. If all job-site conditions are in order, set the un-opened cartons indoors and spread across sub-floor. Do not lay boxes directly on concrete floors. Once product is properly acclimated, you may start installation. Open several cartons of flooring at the same time as this can let you balance plank length, color and wood-grain variation in the wood, and ensure planks can be arranged to reflect a homogenous floor covering.

Please advise your dealer immediately if any problems occur, our in-house installation team could be contracted to take over the installation if required. To avoid any variation in internal wood moisture levels before installation, avoid exposing the cases to rain or snow. Never store planks in unsuitable locations such as a shed, unheated garage, or basement.

IMPORTANT: Prior to installing the floor, installer and homeowner must ensure that the installation site and sub-floor meet the conditions in this document. Installer and homeowner are responsible for inspecting floor planks prior to installing them. Depending on the type of installation, you may also need special moldings for your floor such as nosing and reducer strips.

NAIL DOWN INSTALLATION

Nail installation is only used with PS-2 rated oriented strand board (OSB) or plywood sub-floors. Manufacturer recommends using 3/4" (18 mm) OSB or plywood on joists spaced no more than 19.2" (450 mm) apart, center-to-center. OSB or plywood must be structurally sound.

Recommended tools

1. Moisture Meter
2. Hardwood Flooring Cleat-Nailer with ½" adapter plate (L-cleats only)
3. Chalk reel
4. Tape measure
5. Hammer
6. Pull bar
7. Knocking block
8. Electric Drill and 3/32" bit
9. Finishing spiral nails, and nail set
10. Use non-tarred felt paper on sub-floor surface to reduce normal mechanical friction, and a 6 mil. Poly sheeting, if additional moisture protection is required.
11. Speed square
12. Floor screws
13. Electric saw or Hand saw

Preparing and leveling the sub-floor:

- The sub-floor must be firmly fixed to the joists to avoid any panel movement that could cause creaking. Use flooring screws if necessary to prevent creaking.
- The sub-floor surface must be level. The difference in level must not exceed 3/16" (5 mm) over a distance of 6' (1830 mm). Eliminate small surface irregularities with a sander or floor leveler.

- The surface must be clean. Remove glue residue and staples, and drive in protruding nails.
Remove debris and dust with a broom or vacuum.
- It is recommended that you use non-tarred felt paper on the sub-floor surface to reduce normal mechanical friction between materials and facilitate installation. Lay the felt paper in the direction of the boards using staples, overlapping the ends by 3" to 4". Drive in staples.

Using the nailer:

- Practice using the floor nailer on a scrap plank. Follow the safety tips and instructions of the nailer manufacturer.
- Clean the nail base plate regularly to ensure it does not damage the finish.
- If you are using a pneumatic nailer, adjust the compressor air pressure for the hardness of the species and to insure proper nail placement in tongue (about 80-90 psi). Follow the safety tips and instructions of the nailer manufacturer.

Nail Down Installation Steps

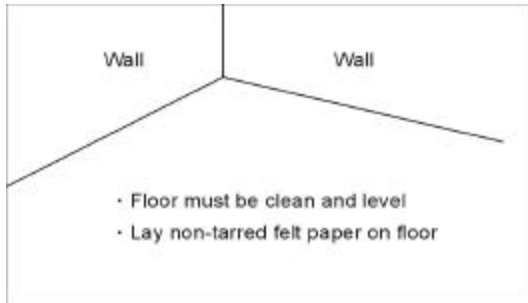

Lay 15 lb non-tarred felt paper or equivalent (with 3" to 4" overlapping end) in the direction of the boards using staples. This will reduce the normal mechanical friction between materials and facilitate installation.

Felt paper is not required if floor has an acoustic membrane.

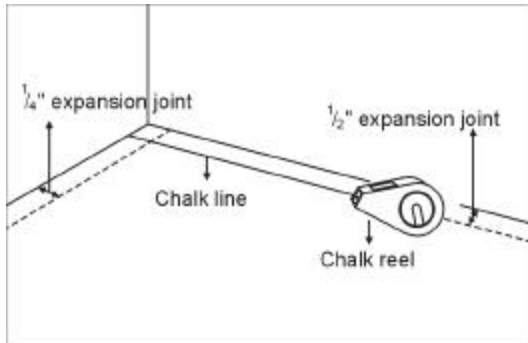

Use chalk line to trace starting line with 1/2" expansion joint at the side and 1/4" at row end.

Lay out 4 to 5 rows of planks ahead of time that match in terms of joints and color. Cut out imperfections on planks or place them in less visible areas.

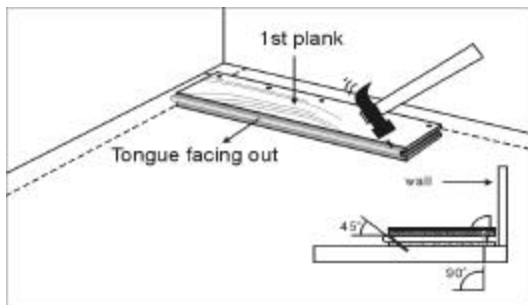

Install the 1st plank along the starting line with the tongue facing out and groove facing the wall.

1st row must be hand-nailed. Drill holes at a 90° angle on the surface of the plank. Drive nails head in with a nail driver. Then drill holes at a 45° angle in the tongue and fasten with spiral nails.

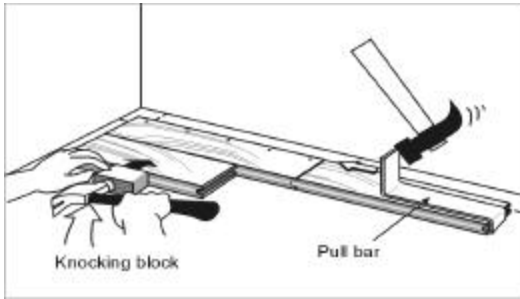

Cut plank to fit end row, allowing for $\frac{1}{4}$ " expansion gap and fasten with pull bar.

Start subsequent row using the remainder of the cut-off end plank from previous row. The remainder should be at least 6". Fasten with knocking block at the side.

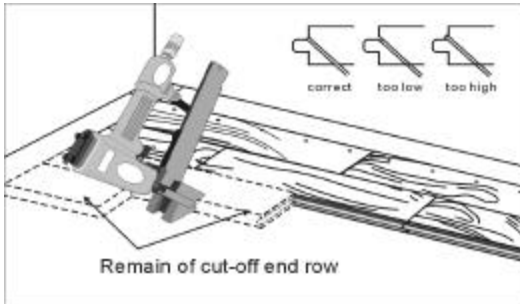

Use manual or pneumatic nailer for subsequent rows. Each plank should be nailed every 6". Do not nail less than 2" from plank end to prevent the tongue from splitting. Fasten each plank with at least 2-nails. For best results, stagger the joints 6" to 8" from the previous row and alternate board lengths.

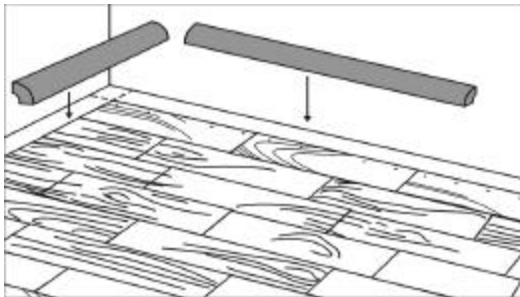

The final planks should be installed the same way as the 1st plank.

You may have to rip the last row lengthwise to leave a $\frac{1}{2}$ " for expansion joint.

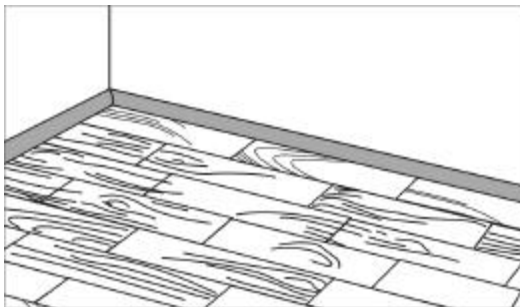

Complete installation with moldings.

GLUE DOWN INSTALLATION

Thomasville engineered flooring can be glued directly to a concrete sub-floor, wood sub-floor, or terrazzo on the ground floor and second floor. Must not be installed over any type of vinyl; vinyl must be removed. Subfloor must be free of wax, paint, oil and debris. Terrazzo floors must be cleaned and stripped of all polishes.

Recommended tools

1. Moisture Meter
2. Bostik BEST or equivalent moisture-cured urethane adhesive
3. Bostik MVP moisture barrier (if required)
4. Notched Trowel-- follow Glue Manufacturer's guidelines for recommended size
5. Bostik Ultimate Adhesive remover or wipes
6. Guide Strip
7. Chalk reel
8. Tape measure
9. Hammer
10. Pull bar
11. Knocking block
12. Speed square
13. Flooring straps
14. 100 lb Roller
15. Electric saw or Hand saw

IMPORTANT: Do not apply any tape to the surface of your floor at any time during installation, or thereafter. This includes "special" tapes that say they are made for wood flooring.

Preparing and leveling the sub-floor:

- The sub-floor should be free of any surface defect. If it is not, fill gaps with a Portland-based leveling cement (for concrete floors only) or sand down uneven areas.
- The sub-floor must be level, i.e., a slope of no more than 3/16" (5 mm) over 10' (3048 mm).
- The surface must be clean and free of debris and contaminants such as wax, paint, grease, dust, oil, nails, staples, etc
- For concrete installation, ensure that the concrete is not low-density (below 3000 psi) or friable.

Glue Down Installation Steps

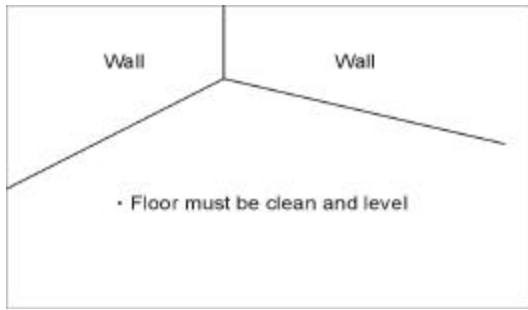

Lay out 4 to 5 rows of planks ahead of time that match in terms of joints and color. Cut out imperfections in planks or place them in less visible areas. For concrete installation, ensure concrete is not low-density (below 3000 psi.).

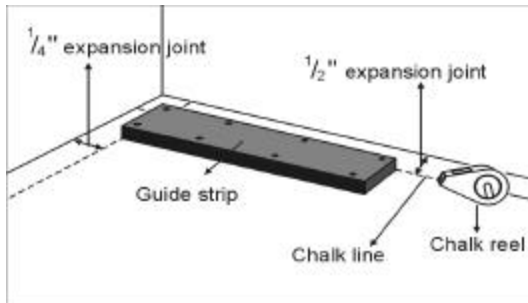

Use chalk line to trace starting line with $\frac{1}{2}$ " expansion joint at the side and $\frac{1}{4}$ " at row end. Nail the guide planks along the starting line. The plank will serve as a guide for the 1st row of plank. Width of the guide plank will be the same as the width of the flooring you choose.

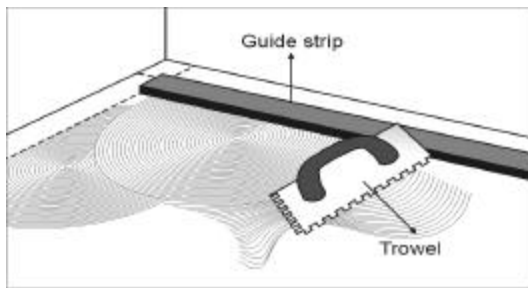

Use the trowel and apply adhesive at a 45° angle from the starting line outward. Install the first plank along the guide strip with tongue facing you and the groove facing the starting wall. The adhesive should not be applied if the subfloor or room temperature is above 85°F (29.6°C) or below 50°F (10°C).

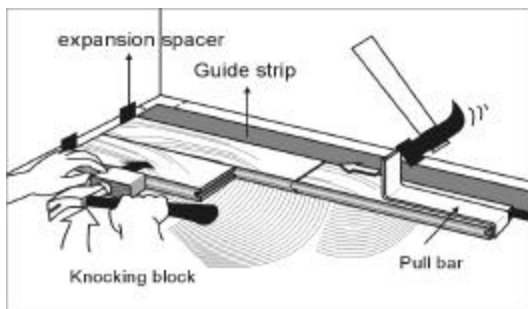

Proceed from left to right to install other planks in the rows. Do small sections to ensure adhesive does not dry before the planks are laid. Use knocking block and pull bar to fasten the joint. As you work, immediately clean any adhesive from the wood surface

Start subsequent row using the remainder of the cut-off end plank from previous row. The remainder should be at least 6".

Insert the tongue end into the groove and lower the plank as close as possible to the adjacent one, avoiding contact with the adhesive as much as possible.

For best results, stagger the joints 6" (150 mm) to 8" (200 mm) from the previous row and alternate board

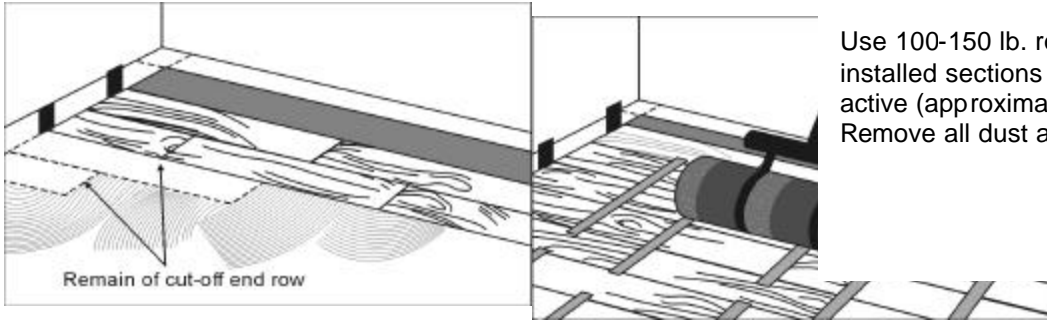

Use 100-150 lb. roller to apply pressure to installed sections while the adhesive is still active (approximately 45-60 min). Remove all dust and debris prior to rolling.

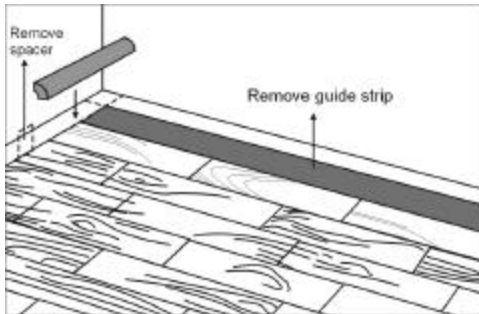

When the surface is covered, remove the expansion spacers and replace with flooring.

Remove the expansion spacer to install the expansion joint.

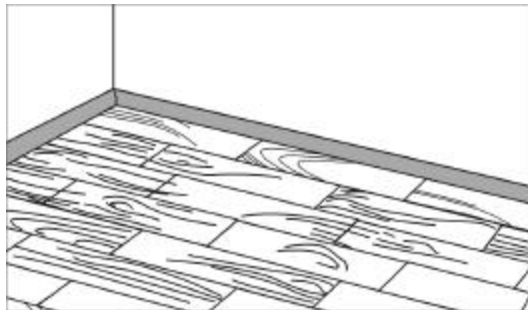

Complete installation with moldings.

Do Not walk or place any personal belongings on newly installed floor for at least 24 hours, this will enable Adhesive to properly cure.

IMPORTANT: During Installation, immediately wipe any adhesive from the floor surface using Bostik's Ultimate solvent and/or wipes.

FLOATING INSTALLATION

Thomasville engineered floor is suitable for floating installation at any grade level, be it above grade, on grade or even below grade onto a concrete sub-floor, wood sub-floor, ceramic tiling, or linoleum with proper site preparation.

Recommended tools

1. Moisture Meter
2. 6 mil. Polyfilm and Foam underlayment OR 2-in-1 foam underlayment
3. Poly or Duct tape
4. Titebond Tongue & Groove wood glue
5. Flooring straps
6. Expansion Spacers
7. Chalk reel
8. Tape measure
9. Hammer
10. Pull bar
11. Tapping block
12. Speed square
13. Electric saw or Hand saw

Preparing and leveling the sub-floor:

- The sub-floor must be level, i.e., a slope of no more than 3/16" (5 mm) over 10' (3048 mm).
- The surface should be clean and free of particles.
- If below grade, lay a 6-mil Polyfilm with seams overlapping 8" (200 mm).
- Fasten seams every 18" to 24"(450 to 600 mm) with duct tape or poly tape.
- Run 4" (100 mm) of poly-film up against the perimeter of wall.
- Lay foam underlayment by butting edges and duct tape the full length of the seam.

Floating Installation Steps

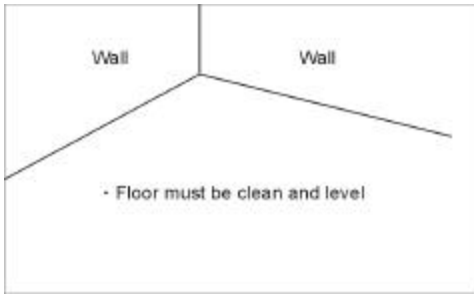

The sub-floor should be free from any surface defect. If it is not, fill gaps with Leveling material designed for your subfloor type.
Lay out 4 to 5 rows of planks ahead of time that match in terms of joints and color.
Cut out imperfections in planks or place them in less visible areas.

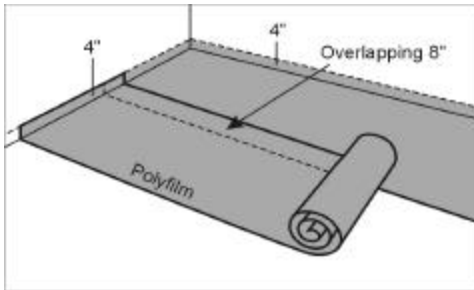

Lay out a layer of 6 mil Polyfilm and layer of foam underlayment OR 2-in-1 foam underlayment.
Run 4" of the Polyfilm up against the perimeter walls.

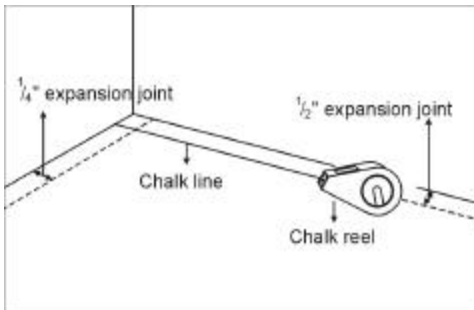

Use chalk line to trace starting line with $\frac{1}{2}$ " expansion joint at the side and $\frac{1}{4}$ " at row ends.
Place expansion spacers every 12" along walls to prevent movement during installation.

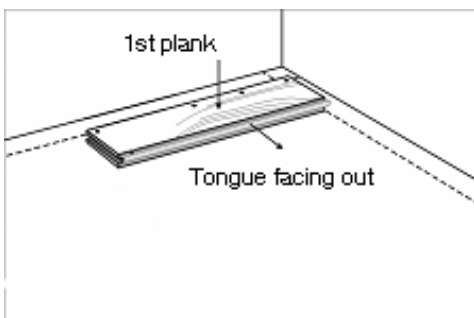

Install 1st plank along the starting line with the tongue facing out.
Start installation on right side of room.

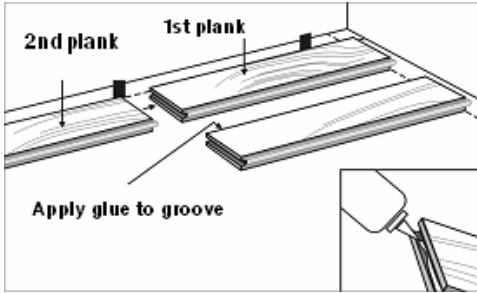

Install from right to left.

Apply bead of Titebond T & G glue to upper inside of groove.

Never apply glue to tongue.

As you work, immediately clean any adhesive from the wood surface.

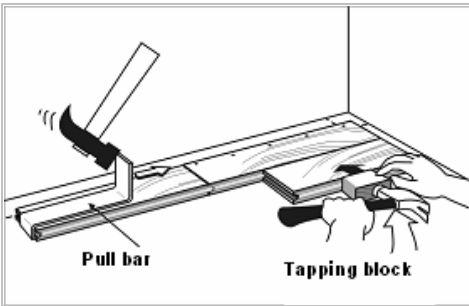

Use pull bar to tighten end joint and knocking block for the side.

Use flooring straps if needed, but Do Not over tighten, this will cause undue stress to joint, and prevent proper adhesion.

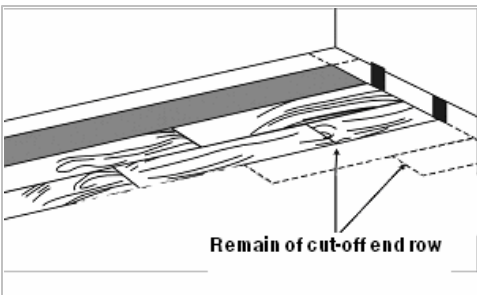

Start subsequent row using the remainder of the cut-off plank from previous row.

The remainder plank must be at least 6" in length.

For best results, stagger the joints 6" to 8" from the previous row and alternate board lengths.

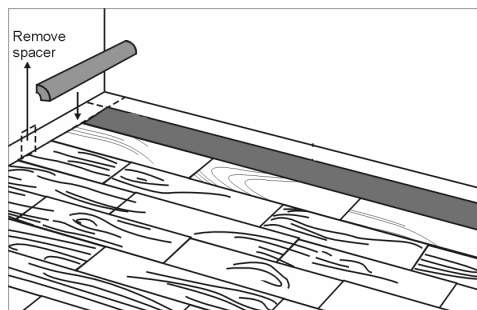

Once the entire surface is covered, remove the expansion spacers to install molding to cover the expansion joint.

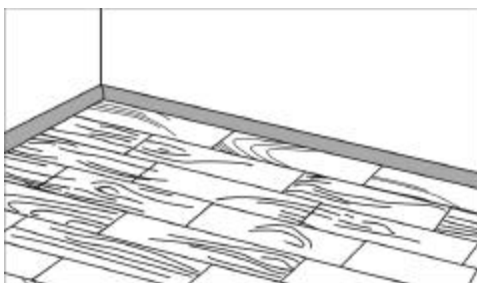

Complete installation with moldings.

Do Not walk or place any personal belongings on newly installed floor for at least 24 hours, this will enable Adhesive to properly cure.

IMPORTANT: During Installation, immediately wipe any adhesive from the floor surface.

Part II – MAINTENANCE & CARE

Finishing & Maintenance

You can hide the small holes left by finishing nails with wood putty.

1. Fill the hole.
2. Wipe excess wood putty immediately with a clean cloth and cleaner.
3. Apply a thin coat of urethane to the clean surface of the putty.
4. Let it dry for about 1 hour.

Regular Maintenance

Clean your wood floors with a damp cloth or terrycloth mop/applicator. Wipe in the direction of the grain (length of the boards.)

Waxing is NOT recommended. Just dust, mop or vacuum your wood floor as needed. Never wet-mop, or flood your floor with water.

Never use cleaners that contain oil soaps or surfactants.

Set up precautions and a regular maintenance program depending on your specific traffic conditions.

Preventive Maintenance

- Install floor protectors on all furniture legs, especially if it has the potential of moving on the wood. Make sure you use the correct size and pad thickness for the weight and size of the furniture.
- Clean and replace felt pads yearly or sooner if they are thinning out or damaged.
- Gritty sand and dirt are abrasive to wood floors. Use protective mats at doorways.
- Use rugs (non rubber-back) in high traffic areas, such as at all exterior doors, in front of refrigerator, dishwasher and sink.
- Keep floors clean and free of dirt & sand. Dust mop and/or vacuum as needed. Do not use a vacuum that has a beater bar, metal wheels, and/or metal or hard plastic attachments. Best to use felt or fine brush attachments. Make sure plastic wheels are free of dirt prior to vacuum.
- Wipe up spills immediately.

- NEVER clean your floor with water or cleaners that mix with water.
- NEVER clean your floors with water or a dampened sponge mop.
- NEVER use furniture duster sprays on wood floors.
- NEVER use cleaners that contain oil soaps or surfactants.
- NEVER use a Sharp Steamer or any other type of steam cleaning machine on wood floors.
- Some types of high heel shoes may cause indentations in wood floors. High-heels worn by an average woman can exert 8,000 pounds per square inch!
- All dogs, especially large dogs, will cause scratches and dents in a wood floor.

Part III WARRANTY

Duty and Responsibility of Installer and Homeowner

Though the manufacturer conducts meticulous quality tests to ensure the floor planks comply with the established criteria, installers must use discretion when choosing planks, omit certain planks, place them in a less visible area, or cut those with serious defects as needed, regardless of their origin. If installers have doubts about the grade and finish or manufacturing quality and can neither place the planks in a less visible area nor eliminate the imperfection, they should not install them. Planks that have been installed are considered having been accepted by the installer and homeowner. The manufacturer will decline any responsibility for failure to strictly follow all installation instructions and recommendations and / or the use of improper materials and tools.

Warranty covers the wood flooring only. Labor and labor costs incurred by the buyer are excluded.

Industrial Norm

Thomasville engineered wood flooring planks are made of natural wood and, as with all natural materials, certain imperfection may or may not exist. Your purchase is subject to rigorous quality standards and complies with current wood industry standards, which stipulate an accepted imperfection rate within 5% of the floor planks. This includes natural imperfections in the wood as well as manufacturing and grade selection defects.

Only products with a defect rate above the acceptable 5% level will be replaced. Warranty will not be applicable for cases of careless installation of product or the poor judgment of installers.

Labor and installation costs will not be covered when the warranty is in practice.

Structural Warranty

The manufacturer warrants that the engineered wood flooring wear layer will not wear-through in 30 years under normal residential traffic. This applies to structural manufacturing defects in lamination when used under normal residential traffic conditions. Proper job site pre-inspection, installation and maintenance procedures must be followed. Adhesion breakdown caused by moisture damage and/or water damage is not covered under this warranty. Engineered wood flooring, being a natural product, will constantly expand and contract over time. Properly installed floors may consequently experience some separation between planks; the planks are not covered under this warranty. This limited warranty extends only to the original purchaser(s) of this product for as long as they own their home and is not transferable.

Finish Warranty

The manufacturer warrants that the engineered wood flooring finish will not wear-through in 15 years from the time of purchase under normal residential traffic. Proper job site pre-inspection, installation and maintenance procedures must be followed. Adhesion breakdown caused by moisture damage and/or water damage is not covered under this warranty. This limited warranty extends only to the original purchaser(s) of this product for as long as they own their home and is not transferable.

Warranty Disclaimers and Exclusions

Color variations are natural due to species, age, character of wood and exposure to sunlight. New and replacement planks may not match display samples or existing flooring.

Matching of flooring to other wood products such as cabinets, stair railings and moldings is the responsibility of the purchaser.

Naturally occurring wood characteristics such as wood grain, color, mineral streaks and knots are not considered defects.

Normal exposure to sunlight will result in changes in shades and colors. Variation of shades between covered and uncovered areas is common. This is not a product defect. Jatoba is a photosensitive wood species.

Rubber-backed rugs may cause finish discoloration.

Gloss reduction is common due to various reasons, including surface wear.

Adhesion breakdown caused by moisture damage and/or water damage is not covered under this warranty.

Engineered flooring must only be used indoors. This warranty will not apply if the flooring is used in any outdoor applications.

Engineered flooring must be properly maintained in accordance with the enclosed maintenance instructions. Any wear-through warranty must not have occurred as a result of improper maintenance, refinishing or accidents, such as damages caused by scratching, impacting or cutting.

Any attempt to repair the engineered flooring will void this warranty.

This warranty does not apply to water damage caused by flooding, standing water or hydrostatic pressure.

General Disclaimer

This warranty excludes indentations, scratches, stains or damages caused by negligence, fire, water, moisture, excessive heat or excessive dryness, erosion, pebbles, sand or other abrasives, pets, insects, high heeled shoes, weather conditions or natural disasters, color variations, naturally occurring wood characteristics, failure to follow the written installation and maintenance instructions, improper maintenance, insufficient protection, misuse or improper alterations of the original manufacturer's product.

This warranty does not cover natural product expansion and contraction through time resulting in separation between planks or damage due to exposure to excessive low or high humidity for a long period of time.

This warranty only applies to the purchase through The Home Depot with legal proof. It does not cover downgraded or discounted purchase.

Any and all representatives, promises, warranties or statements by agents that differ in any manner from this terms of limited warranty shall be void and in no force unless in written form and signed by a duly authorized party.

All claims shall be reviewed on whether the finding should be justified to be conducted by an independent flooring inspector. If the defect is due to other factors, a written reply shall be issued to the claimer together with reasons.

Should a third party inspector be required, the claimer will be required to make a payment for the inspection. The payment will be determined by the company of the independent inspector. The inspector will perform an on-site inspection and will provide a full report to both parties. The inspector must be licensed, and certified in wood flooring inspection.

Should the report not be justified for claim, the case will be considered dissolved and the claimer will have to bear the cost of the inspection. If justification is claimable, the manufacturer will provide suggestion to claimer to reach an agreement for reimbursement and settlement.

Limitations on Liability

Consumer exclusive remedy and manufacturer's sole liability on any claim, whether in tort, contract, or breach of warranty, shall be limited to the repair or replacement of the defective goods for the affected area only which are proven to manufacturer's satisfaction to be defective in manufacture or the refund of the applicable purchase price. In no event and for no cause whatsoever, including any breach or default by manufacturer, shall manufacturer have any other liability (including without limitation incidental or consequential damages) or any monetary liability to consumer in excess of the contract price or prices of the pertinent products in question. All charges should be submitted to the Customer Relations Department for evaluation and review.

**Customer Relations Department
Warranty Service Line: 800-278-8204**