

CITY OF
FORT WALTON BEACH

ENGINEERING STANDARDS MANUAL



CITY OF FORT WALTON BEACH
ENGINEERING STANDARDS MANUAL

TABLE OF CONTENTS

SECTION 1.00 – INTRODUCTION3

SECTION 2.00 – POLICY.....3

SECTION 3.00 - EROSION AND SEDIMENTATION CONTROL3
EROSION AND SEDIMENTATION CONTROL STANDARD DETAILS
 ESM- 3.01 Silt Fence..... 4
 ESM -3.02 Floating Turbidity Barrier..... 5
 ESM -3.03 Inlet Protection..... 6

SECTION 4.00 – STORMWATER7
4.01 – Design Standards7
4.02 – Stormwater As-builts8
STORMWATER STANDARD DETAILS
 ESM - 4.01 Retention Pond..... 9
 ESM - 4.02 Detention Pond..... 10
 ESM - 4.03 Type “C” Catch Basin 11
 ESM - 4.04 Type “D” Catch Basin 12
 ESM - 4.05 Type “E” Catch Basin..... 13
 ESM - 4.06 Oil Skimmer for Outfall Structure 14
 ESM - 4.07 Mitered End Section and Concrete Collar 15
 ESM - 4.08 Standard Saddle Curb Inlet 16
 ESM - 4.09 Standard French Drain 17
 ESM - 4.10 Standard Underdrain Exfiltration 18

SECTION 5.00 – STREETS.....19
5.01 – Street Layout19
5.02 – Pavement Design19
5.03 – Curb & Gutter20
STREETS STANDARD DETAILS
 ESM - 5.01 2-Lane City Street (60’ ROW)..... 21
 ESM - 5.02 4-Lane Undivided City Street (96’ ROW) 22
 ESM - 5.03 4-Lane Divided City Street (112’ ROW)..... 23
 ESM - 5.04 Standard Cul-de-sac..... 24
 ESM - 5.05 Standard Offset Cul-de-sac 25
 ESM - 5.06 Standard T – Turn Around 26
 ESM - 5.07 Standard 2’ Ribbon Curb..... 27
 ESM - 5.08 Standard Drop Curb 28
 ESM - 5.09 Standard Squareback Curb 29
 ESM - 5.10 Standard Rollback Curb & Gutter 30

SECTION 6.00 PARKING & VEHICULAR ACCESSABILITY31

Attachment: Engineering Standards Manual Draft (2016 : Approval of the Engineering Standards Manual)

6.01 – Off Street Vehicle Parking31

6.02 – Off Street Vehicle Loading31

6.03 – Bicycle Parking.....31

6.04 – Parking Lot Design Standards31

PARKING AND VEHICULAR ACCESSABILITY STANDARD DETAILS

ESM - 6.01 Bicycle Parking 32

SECTION 7.00 SIDEWALKS, MULTI-USE PATHS & DRIVEWAYS33

7.01 – Sidewalk Design Standards.....33

7.02 – Multi-use Path Design Standards.....33

7.03 – Driveway Design Standards34

SIDEWALKS, MULTI-USE PATHS & DRIVEWAY STANDARD DETAILS

ESM - 7.01 Standard Sidewalk 35

ESM - 7.02 Multi-use Path 36

ESM - 7.03 Standard Residential Driveway 37

ESM - 7.04 Standard Commercial Driveway 38

ESM - 7.05 Standard Commercial Driveway with Sidewalk at Back of Curb 39

ESM - 7.06 Standard Driveway Turnout Curb & Gutter 40

SECTION 8.00 ROADSIDE APPENDITURES41

8.01 – Solid Waste Receptacle Pads41

ROADSIDE APPENDITURE STANDARD DETAILS

ESM - 8.01 Standard Concrete Dumpster Pad 42

SECTION 9.00 UTILITIES43

9.01 – Utility Easements43

9.02 – Potable Water43

9.03 – Sanitary Sewer.....44

9.04 – Drainage.....45

9.05 – Reclaimed Water45

9.06 – Utility As-builts45

UTILITY STANDARD DETAILS

ESM - 9.01 Numbers to Call for Line Spots and Other Utility Information 46

ESM - 9.02 Standard Utility Section 47

ESM - 9.03 Standard Utility Locations..... 48

ESM - 9.04 Water & Sewer Main Crossing/Separation..... 49

ESM - 9.05 Typical Reclaimed Water/Potable Water Crossing..... 50

ESM - 9.06 Concrete Arch & Encasement..... 51

ESM - 9.07 Standard Utility Patch Restoration 52

ESM - 9.08 Trench – Type “A” Bedding..... 53

ESM - 9.09 Trench – Type “B” Bedding..... 54

ESM - 9.10 Standard Thrust Block..... 55

ESM - 9.11 Gate Valve – 12” & Smaller..... 56

ESM - 9.12 Standard Fire Hydrant..... 57

ESM - 9.13 ¾” – 2” Water Meter Installation 58

ESM - 9.14 4” & Larger Water Meter Installation..... 59

ESM - 9.15 Sanitary Sewer Service Lateral..... 60

ESM - 9.16 Standard Sewer Cleanout 61
 ESM - 9.17 Standard Sewer Manhole 62
 ESM - 9.18 Standard Sewer Manhole with Drop Connection..... 63

APPENDIX 9A APPROVED MATERIALS FOR UTILITY CONSTRUCTION

9A-1 Approved Materials for Potable Water Construction 65
 9A-2 Approved Materials for Sanitary Sewer Construction..... 67
 9A-3 Approved Materials for Drainage Construction 68

1.00 INTRODUCTION

The 2012 City of Fort Walton Beach Land Development Code was adopted on March 23, 2012 and became effective on May 1, 2012. Many requirements contained in the previous Land Development Code will now be located in the Engineering Standards Manual (ESM) of Fort Walton Beach. The ESM is referenced throughout the Land Development Code, containing uniform minimum standards for the design and construction of required improvements acceptable within the City of Fort Walton Beach.

2.00 POLICY

The Engineering Standards Manual shall serve as the official document that contains the minimum standards for design and construction of required improvements throughout the City of Fort Walton Beach. The Engineering and Utility Services Director shall establish and maintain the Engineering Standards Manual and such other standards for work within the public rights-of-way.

3.00 EROSION AND SEDIMENTATION CONTROL

Erosion and sedimentation control measures shall be installed around the perimeter of all construction sites that disturb the existing topography. Unless otherwise noted in City standard details, all erosion control measures shall comply with the latest version of the Florida Department of Transportation's (FDOT) Design Standards and the Florida Department of Environmental Protection's (FDEP) Florida Stormwater Erosion Control and Sedimentation Control Inspector's Manual. All development shall provide for erosion and sedimentation control as follows:

- a. An erosion control plan is required as part of the Stormwater Management Plan.
- b. Before the commencement of construction activity, erosion control measures must be installed.
- c. Silt fencing shall be installed around the perimeter of the site to provide for erosion control and define the limits of construction activity.
- d. Onsite and downstream inlets shall be protected by temporary inlet protection.
- e. All soil stockpiles shall be protected against dusting and erosion.
- f. At all times during and after construction, disturbed areas shall be stabilized. Final stabilized areas shall be sodded/seeded and established prior to project closeout.
- g. The requirements of an erosion and sedimentation control may be waived by the City for developments less than one-half (1/2) acre in size and are not located upstream from adjacent properties.

(This section left intentionally blank)

SILT FENCE

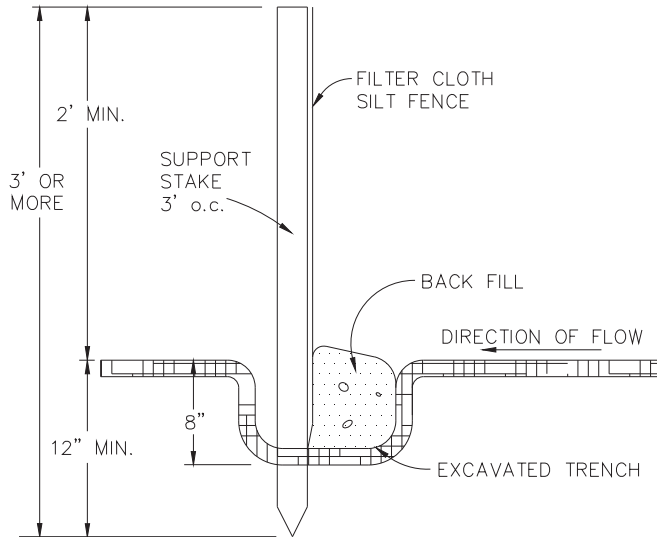

NOTE:
SILT FENCE TO BE CONSTRUCTED AND MAINTAINED AROUND ALL INLETS; ALSO ACROSS DRAINAGE COURSE AT EDGE OF SITE.

EROSION NOTES:

1. ALL SILT FENCING SHALL BE INSTALLED AND SPACED ACCORDING TO FDOT INDEX #102.
2. EROSION PROTECTION, SUCH AS STAKED BALED HAY AND SILT FENCE BARRIERS, MUST BE INSTALLED PRIOR TO START OF CONSTRUCTION.
3. SILT FENCE BARRIER SHALL BE INSTALLED AS SHOWN ON PLANS, AND IN ALL AREAS SUBJECT TO SOIL EROSION SEDIMENTATION, SPECIFICALLY ADJACENT TO ALL BODIES OF WATER AND WETLAND AREAS WHERE THERE IS A POTENTIAL FOR DOWNSTREAM WATER QUALITY DEGRADATION.
4. SEDIMENT AND EROSION CONTROL DEVICES SHALL REMAIN IN PLACE THROUGHOUT CONSTRUCTION AND SHALL BE REMOVED AT COMPLETION OF THE PROJECT.

City of Fort Walton Beach Engineering Standards	SILT FENCE	SCALE: NTS	6-26-2012 KJN	DRAWING # ESM-3.01
--	------------	---------------	------------------	-----------------------

Plotted Tuesday, October 18, 2005 11:03:12 AM - C:\Users\KNITZM~1\FWB\AppData\Local\Temp\VASC64903E65.DWG

Attachment: Engineering Standards Manual Draft (2016 : Approval of the Engineering Standards Manual)

FLOATING TURBIDITY BARRIER

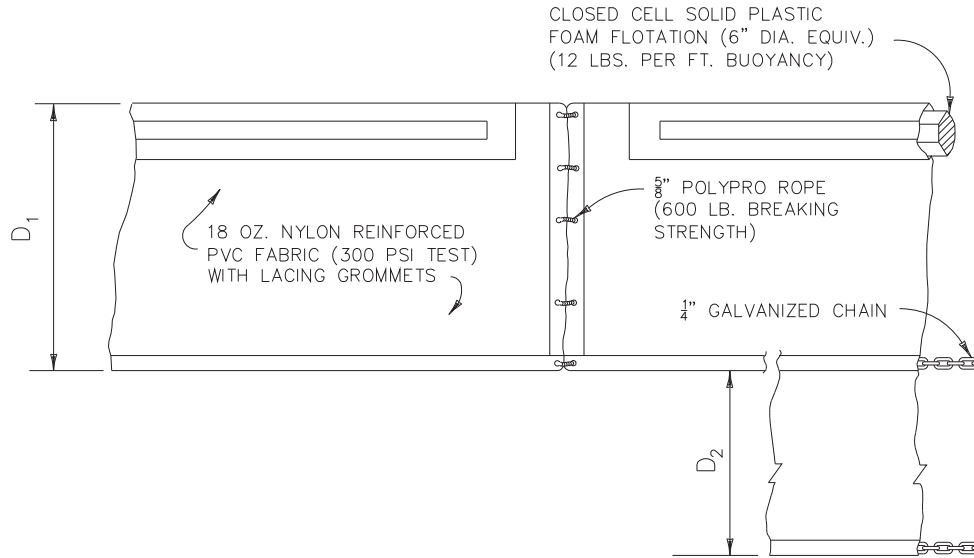

GENERAL NOTES:

1. ALL TURBIDITY BARRIERS SHALL BE INSTALLED ACCORDING TO FDOT INDEX #103.
2. TURBIDITY BARRIERS SHALL BE PROVIDED WHERE CONSTRUCTION ACTIVITIES HAVE BEEN PERMITTED AND WHERE SEDIMENT MOVEMENT INTO TIDAL AND NON-TIDAL WATERCOURSES IS UNAVOIDABLE.
3. TURBIDITY CURTAINS SHALL BE INSTALLED PARALLEL TO TIDAL AND NON-TIDAL FLOWS.
4. UNDER NO CIRCUMSTANCE SHALL PERMITTED LAND DISTURBING ACTIVITIES CREATE VIOLATIONS OF STATE WATER QUALITY STANDARDS.

City of Fort Walton Beach Engineering Standards	FLOATING TURBIDITY BARRIER	SCALE: NTS	6-28-2012 KJN	DRAWING # ESM-3.02
--	----------------------------	---------------	------------------	-----------------------

Plotted Tuesday, October 18, 2005 11:03:12 AM - C:\Users\KNITZM-1\FWB\AppData\Local\Temp\AS096E03C7.DWG

Attachment: Engineering Standards Manual Draft (2016 : Approval of the Engineering Standards Manual)

INLET PROTECTION

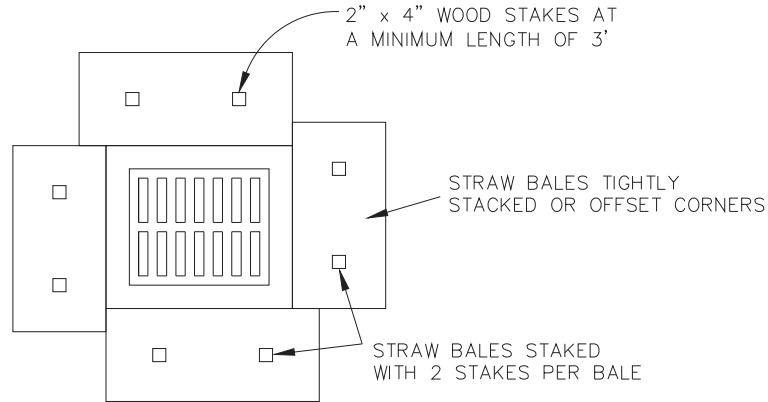

PLAN VIEW

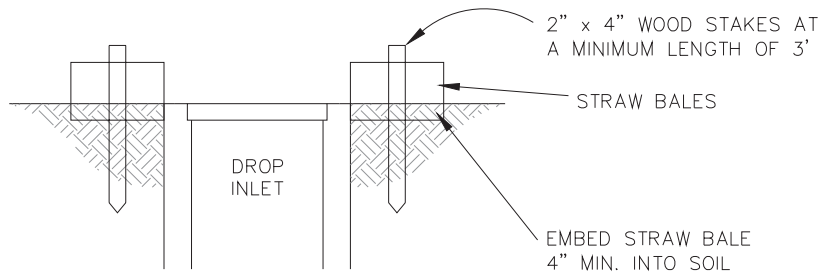

SECTION VIEW

GENERAL NOTES:

1. ALL INLET PROTECTION SHALL BE INSTALLED AND SPACED ACCORDING TO FDOT INDEX #102.
2. THE DRAINAGE AREA SHALL BE NO LARGER THAN 1 ACRE.
3. A SILT FENCE BARRIER IS AN ACCEPTABLE ALTERNATIVE TO STRAW BALES.

City of Fort Walton Beach Engineering Standards	INLET PROTECTION	SCALE: NTS	6-28-2012 KJN	DRAWING # ESM-3.03
--	------------------	---------------	------------------	-----------------------

Plotted Tuesday, October 18, 2005 11:03:12 AM - C:\Users\KNITZM~1\FWB\AppData\Local\Temp\VASCO50F05AF.DWG

Attachment: Engineering Standards Manual Draft (2016 : Approval of the Engineering Standards Manual)

4.00 STORMWATER

4.01 Design Standards

In order to ensure the objectives and performance standards of this article will be met, the design, construction and maintenance of drainage systems shall be consistent with the following standards:

- a. All developments shall treat the first one (1) inch of runoff on-site and assure that the post development run-off rate will not exceed the pre-development runoff rate for a 25-year storm event, up to and including an event with a 24-hour duration.
- b. Developments that directly discharge into tidally influenced surface waters of the state must still meet treatment volume requirements but are not required to provide attenuation.
- c. For the purpose of design, the published FDOT 25-year: 1-hour, 2-hour, 4-hour, 8-hour, and 24-hour rainfall distributions shall be used to demonstrate stormwater compliance. The City reserves the right to require compliance with additional storm events and water quality standards in areas of special concern as designated by the City.
- d. Channeling runoff directly into water bodies shall be prohibited. Instead, runoff shall be routed and treated through vegetative swales and other systems designed to remove pollutant loads and sediment.
- e. Natural watercourses shall not be dredged or altered.
- f. Wetlands and other water bodies shall not be used as sediment traps during or after development.
- g. Runoff from parking lots shall be treated to remove oil and sediment before it enters receiving waters.
- h. Detention and Retention Areas – The purpose of a detention/retention pond is to serve as a buffer to attenuate peak flows and capture excess runoff from developed areas. The minimum criteria for detention/retention ponds are as follows:
 1. Detention and retention areas shall be designed so that shorelines are sinuous rather than straight and so that the length of shoreline is maximized, thus offering more space for the growth of vegetation.
 2. Detention areas shall be sloped no steeper than four (4) feet horizontal to one (1) foot vertical (4:1) at a minimum of two (2) feet below the water control elevation. Retention areas shall be sloped entirely no steeper than 4:1. As an alternative, three (3) feet horizontal to one (1) foot vertical (3:1) slope is acceptable provided the pond is fenced or somehow safeguarded against public access. Ponds that are fenced must provide adequate room for maintenance activities. The purpose of this requirement is to safeguard against drowning, personal injury, or other accidents.
 3. A minimum of ten percent (10%) of the average pond depth or six inches (6") is required as pond freeboard, whichever is less. Compliance with this requirement must be demonstrated on each required 25-yr storm event.
 4. The pond bottom for all retention areas shall be a minimum of two (2) feet above the estimated ground water table obtained from a signed and sealed geotechnical report.
 5. Percolation rates utilized in stormwater calculations shall be obtained from a signed and sealed geotechnical report. In any circumstance, the maximum design percolation rate is not to exceed twenty-four (24) inches per hour.

6. The treatment volume retained in retention ponds must be designed to percolate within seventy-two (72) hours after a storm event. For detention ponds, a bleed down orifice must be properly sized to drawdown one-half the treatment volume between forty-eight (48) and sixty (60) hours.
7. Although the use of wetlands for detention and purifying water is encouraged, care must be taken not to overload their capacity, thereby harming the wetlands and transitional vegetation. Wetlands should not be damaged by the construction of detention ponds.

4.02 Stormwater As-builts

Upon completion of a project, the Contractor shall produce and submit a signed and sealed full as-built produced by a Florida Registered Land Surveyor. The amount of detail on the record drawings shall include but is not limited to graphic scale, building footprints, grades and contours of the stormwater system, pipe materials, pipe sizes, location of appurtenances, and any other information deemed necessary by the City. The acceptance of the record drawings by the City does not release the Contractor from the liability of the construction. The City reserves the right to verify the record drawings/as-builts prior to acceptance.

(This section left intentionally blank)

RETENTION POND

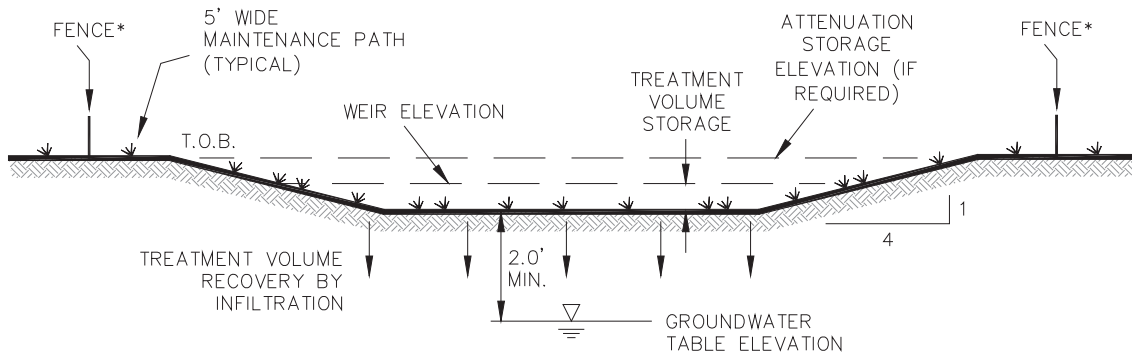

GENERAL NOTES:

1. ENTIRE DISTURBED AREA TO BE SODDED AND SEEDED.
 2. RETENTION POND MUST BE DESIGNED TO RECOVER WITHIN 72 HOURS.
- * IF REQUIRED DUE TO SLOPES EXCEEDING 4:1

City of Fort Walton Beach Engineering Standards	RETENTION POND	SCALE: NTS	6-28-2012 KJN	DRAWING # ESM-4.01
--	----------------	---------------	------------------	-----------------------

Plotted Tuesday, October 18, 2005 11:03:12 AM - C:\Users\KNITZM-1\FWB\AppData\Local\Temp\A\$C00241BD9.DWG

Attachment: Engineering Standards Manual Draft (2016 : Approval of the Engineering Standards Manual)

DETENTION POND

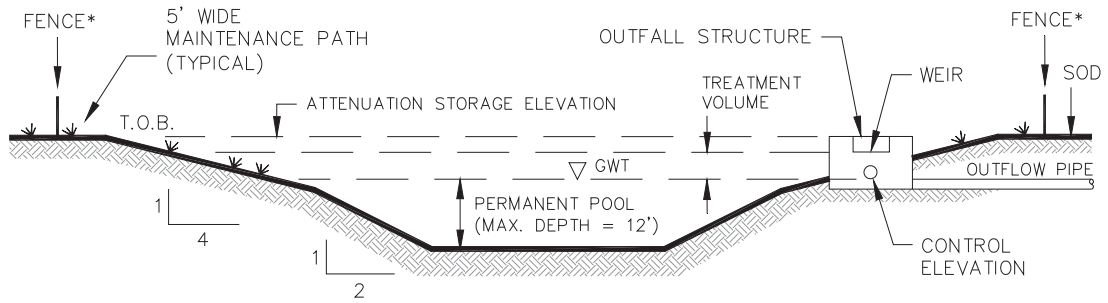

GENERAL NOTES:

1. DETENTION PONDS SHALL BE DESIGNED TO DRAW DOWN BETWEEN 48 AND 60 HOURS.
 2. 4:1 SLOPES SHALL EXTEND NO LESS THAN 2 FEET BELOW THE OBSERVED GROUND WATER TABLE.
- * IF REQUIRED DUE TO SLOPES EXCEEDING 4:1

City of Fort Walton Beach Engineering Standards	DETENTION POND	SCALE: NTS	6-28-2012 KJN	DRAWING # ESM-4.02
--	----------------	---------------	------------------	-----------------------

Plotted Tuesday, October 18, 2005 11:03:12 AM - C:\Users\KNITZM-1\FWB\AppData\Local\Temp\ASCO209419D.DWG

Attachment: Engineering Standards Manual Draft (2016 : Approval of the Engineering Standards Manual)

TYPE "C" CATCH BASIN

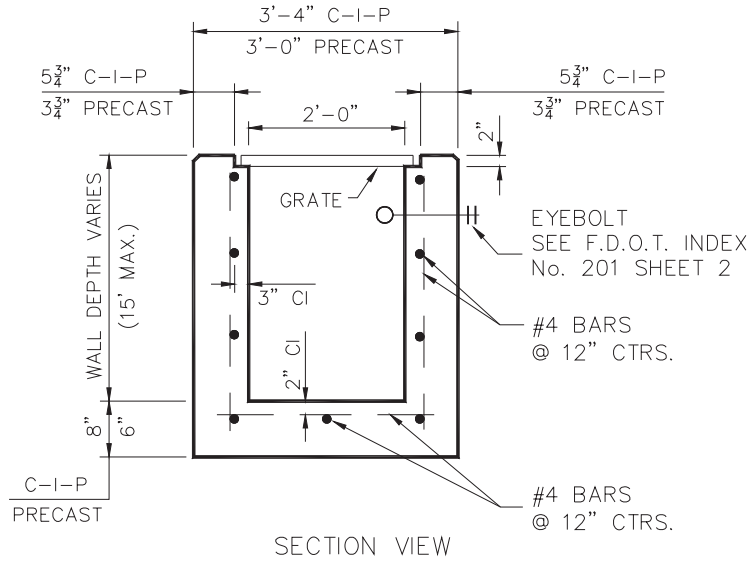
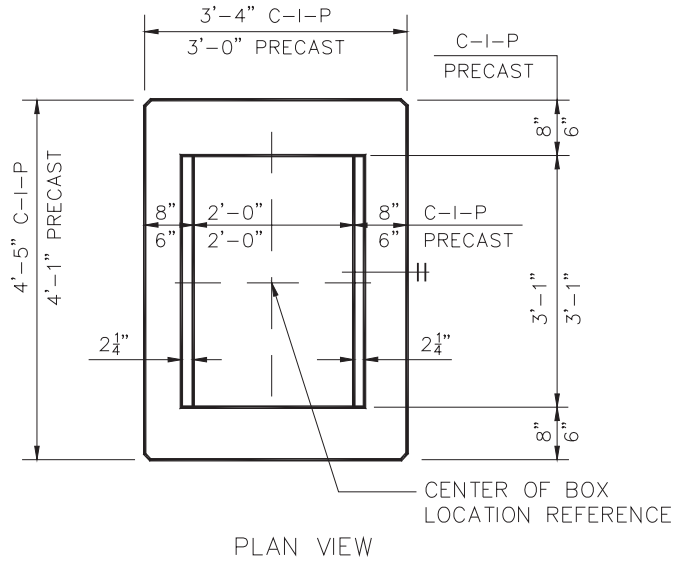

TYPE "C" CATCH BASIN DETAIL
(F.D.O.T. INDEX No. 232)

City of Fort Walton Beach Engineering Standards	TYPE "C" CATCH BASIN	SCALE: NTS	6-28-2012 KJN	DRAWING # ESM-4.03
--	----------------------	---------------	------------------	-----------------------

Plotted Tuesday, October 18, 2005 11:03:12 AM - C:\Users\KNITZM~1\FWB\AppData\Local\Temp\A5C6F4C10A7.DWG

TYPE "D" CATCH BASIN

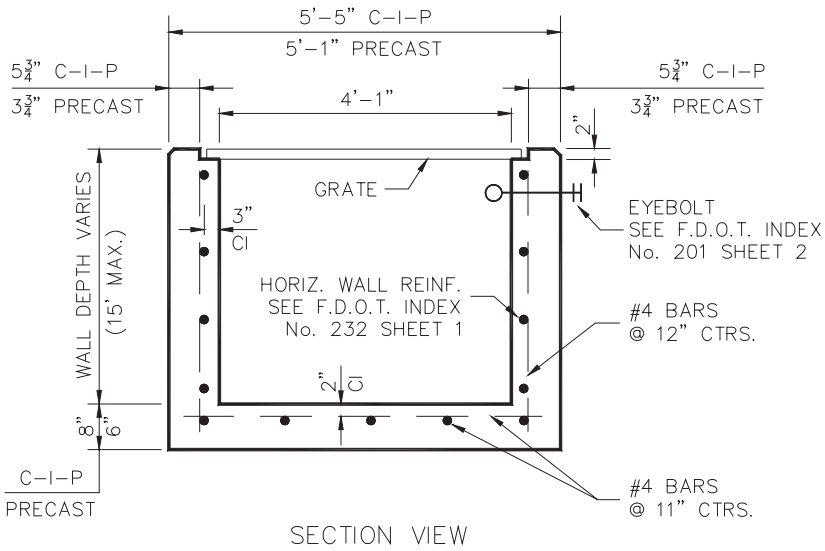
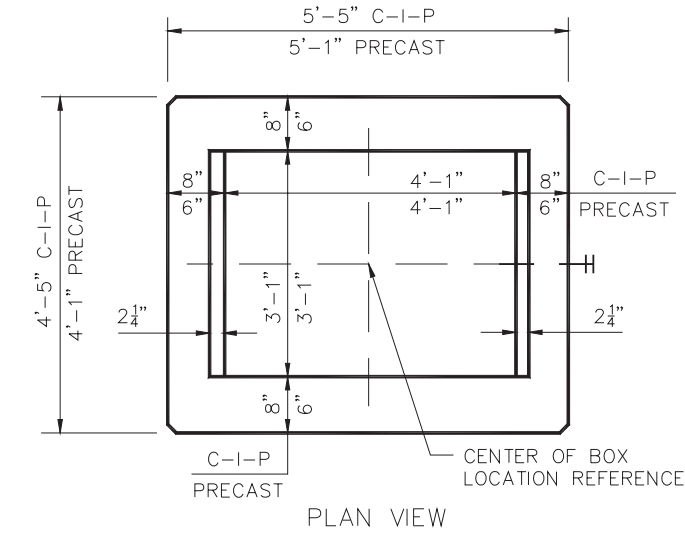

TYPE "D" CATCH BASIN DETAIL
(F.D.O.T. INDEX No. 232)

City of Fort Walton Beach Engineering Standards	TYPE "D" CATCH BASIN	SCALE: NTS	6-28-2012 KJN	DRAWING # ESM-4.04
--	----------------------	---------------	------------------	-----------------------

Plotted Tuesday, October 18, 2005 11:03:12 AM - C:\Users\KNITZM-1\FWB\AppData\Local\Temp\ASCTAC43852.DWG

Attachment: Engineering Standards Manual Draft (2016 : Approval of the Engineering Standards Manual)

TYPE "E" CATCH BASIN

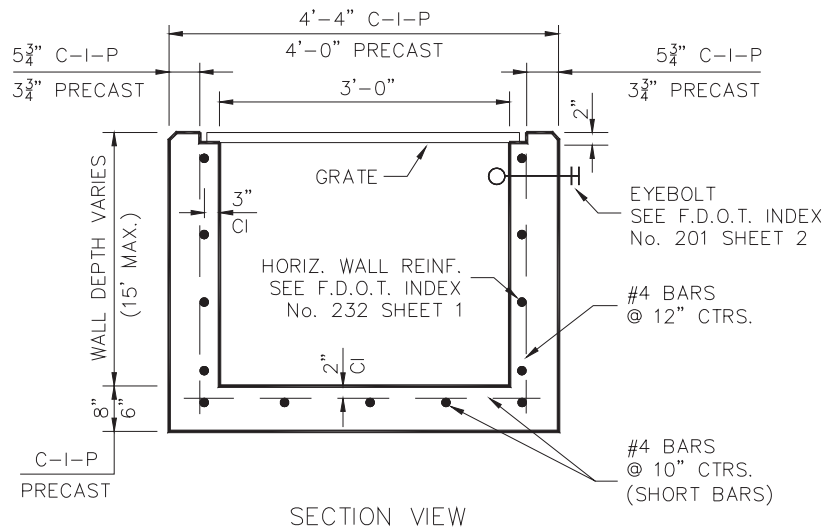
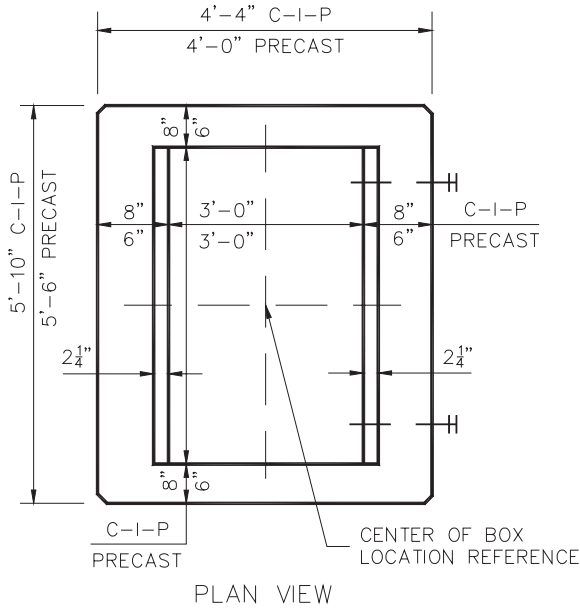

TYPE "E" CATCH BASIN DETAIL
(F.D.O.T. INDEX No. 232)

City of Fort Walton Beach Engineering Standards	TYPE "E" CATCH BASIN	SCALE: NTS	6-28-2012 KJN	DRAWING # ESM-4.05
--	----------------------	---------------	------------------	-----------------------

Plotted Tuesday, October 18, 2005 11:03:12 AM - C:\Users\KNITZM~1\FWB\AppData\Local\Temp\VA5C720A5808.DWG

OIL SKIMMER FOR OUTFALL STRUCTURE

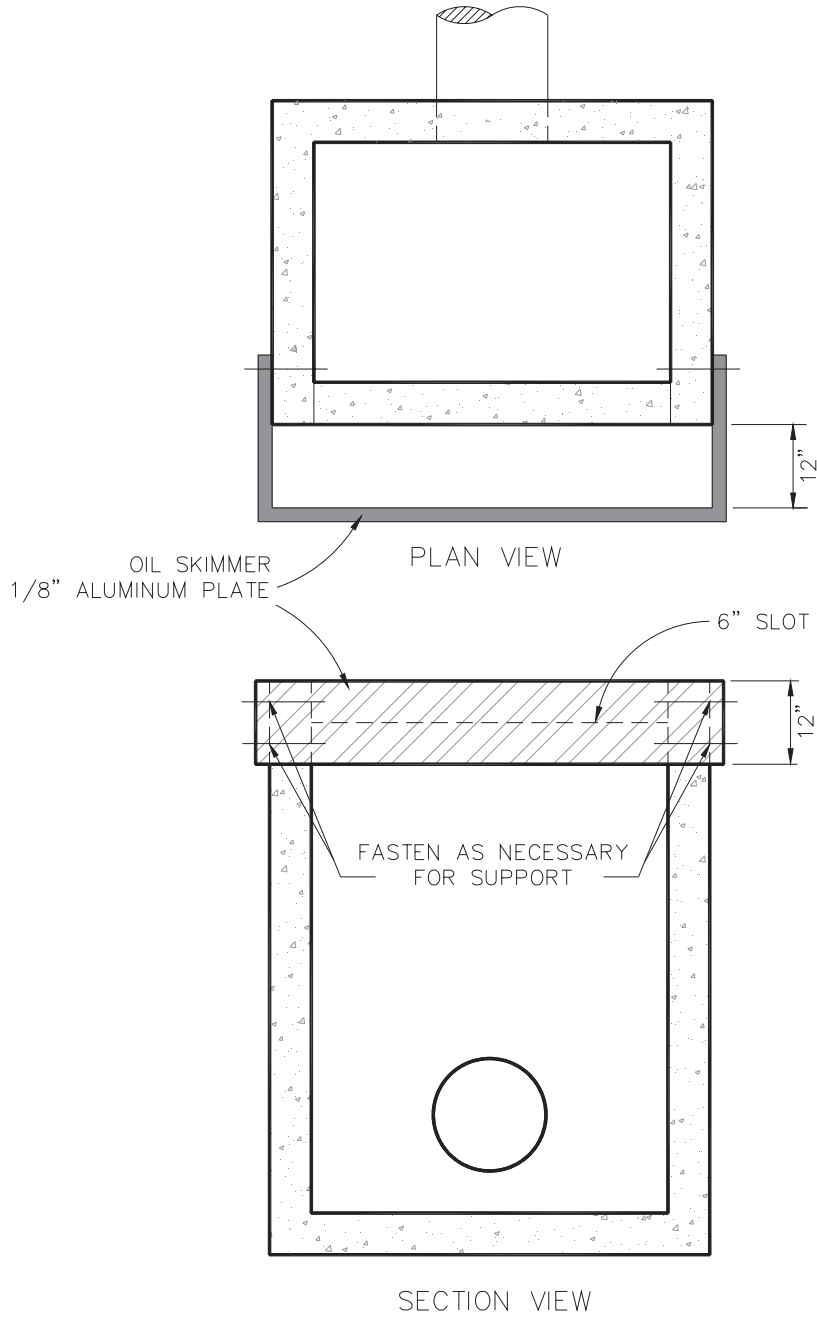

City of Fort Walton Beach Engineering Standards	OIL SKIMMER FOR OUTFALL STRUCTURE	SCALE: NTS	6-28-2012 KJN	DRAWING # ESM-4.06
--	--------------------------------------	---------------	------------------	-----------------------

Plotted Tuesday, October 18, 2005 11:03:12 AM - C:\Users\KNITZM~1\FWB\AppData\Local\Temp\ASC4CCB511C.DWG

Attachment: Engineering Standards Manual Draft (2016 : Approval of the Engineering Standards Manual)

MITERED END SECTION AND CONCRETE COLLAR

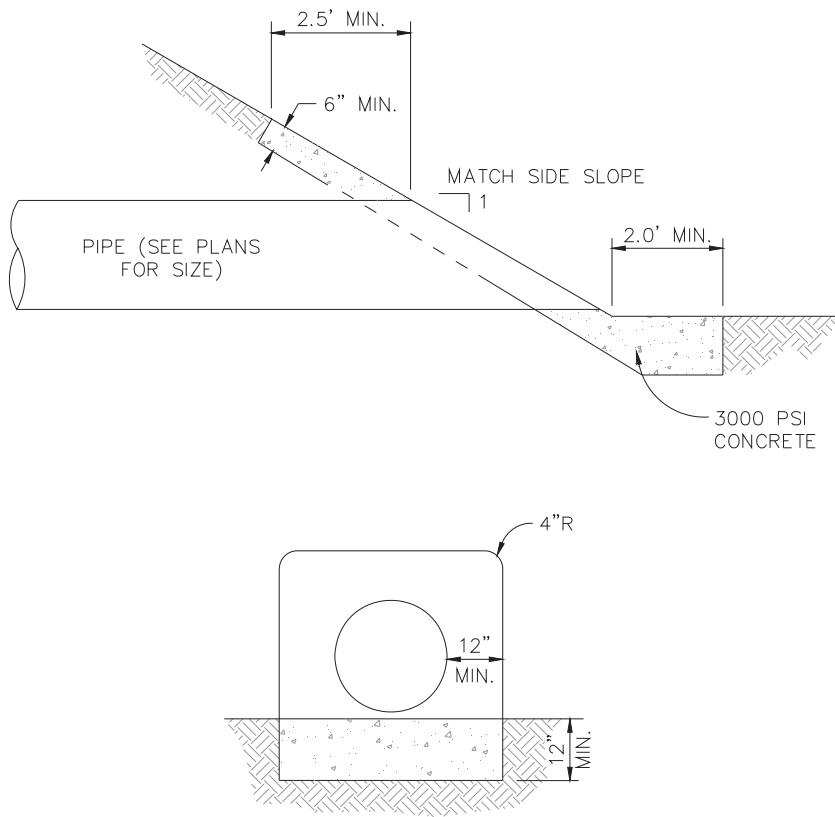

City of Fort Walton Beach
Engineering Standards

MITERED END SECTION
AND CONCRETE COLLAR

SCALE:
NTS

6-28-2012
KJN

DRAWING #
ESM-4.07

Plotted Tuesday, October 18, 2005 11:03:12 AM - C:\Users\KNITZM-1\FWB\AppData\Local\Temp\A5C33CC2EC9.DWG

Attachment: Engineering Standards Manual Draft (2016 : Approval of the Engineering Standards Manual)

STANDARD SADDLE CURB INLET

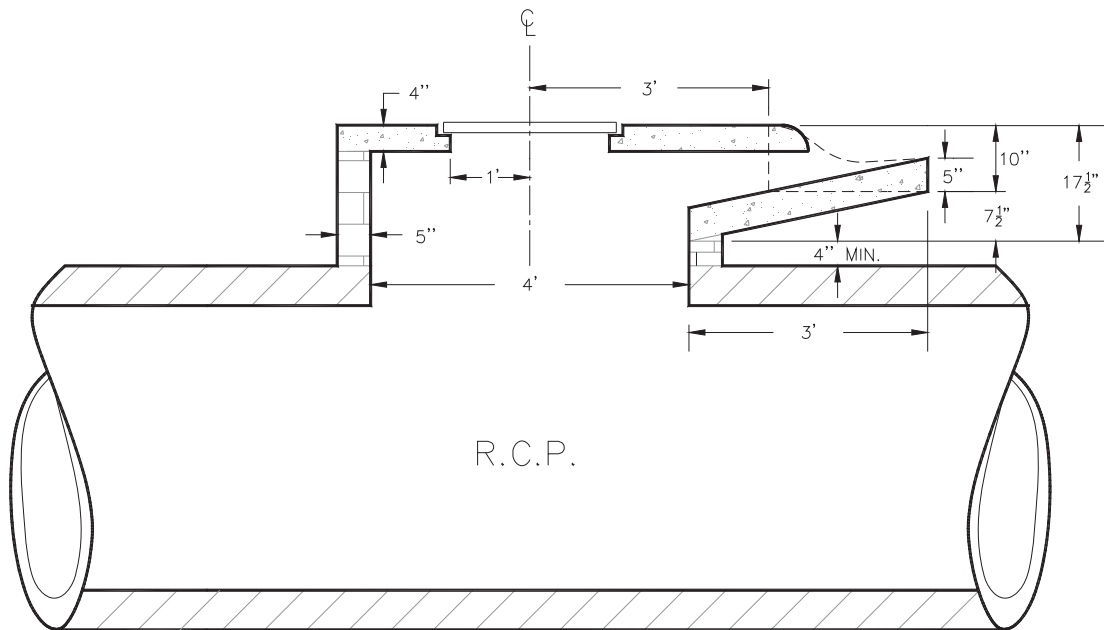

City of Fort Walton Beach
Engineering Standards

STANDARD SADDLE CURB INLET

SCALE:
NTS

6-28-2012
KJN

DRAWING #
ESM-4.08

Plotted Tuesday, October 18, 2005 11:03:12 AM - C:\Users\KNITZM~1\FWB\AppData\Local\Temp\ASCO47B2C45.DWG

Attachment: Engineering Standards Manual Draft (2016 : Approval of the Engineering Standards Manual)

STANDARD FRENCH DRAIN

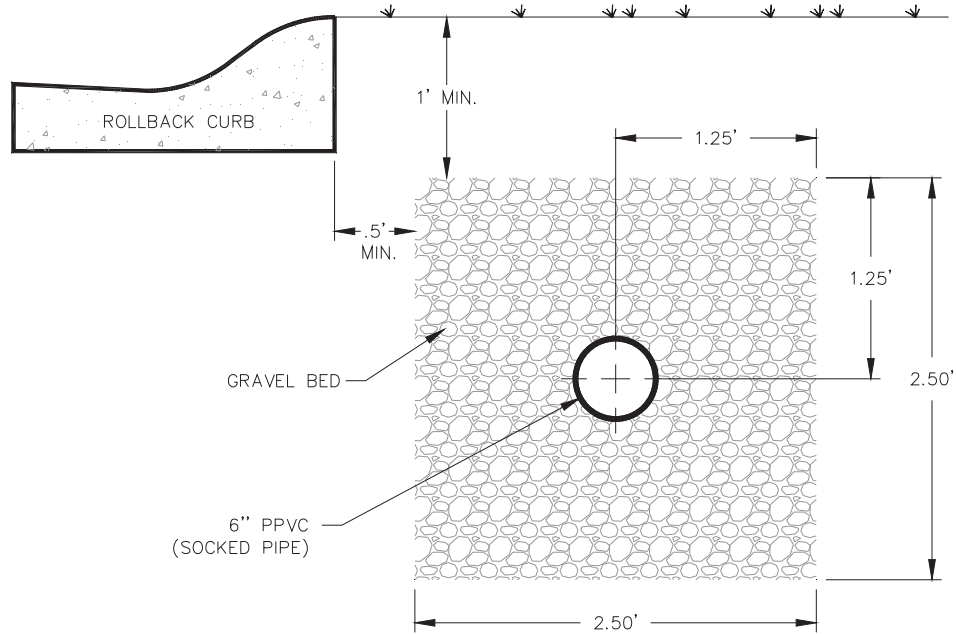

SECTION VIEW

City of Fort Walton Beach Engineering Standards	STANDARD FRENCH DRAIN	SCALE: NTS	6-28-2012 KJN	DRAWING # ESM-4.09
--	-----------------------	---------------	------------------	-----------------------

Plotted Tuesday, October 18, 2005 11:03:12 AM - C:\Users\KNITZM-1\FWB\AppData\Local\Temp\ASC2251152C.DWG

Attachment: Engineering Standards Manual Draft (2016 : Approval of the Engineering Standards Manual)

STANDARD UNDERDRAIN EXFILTRATION

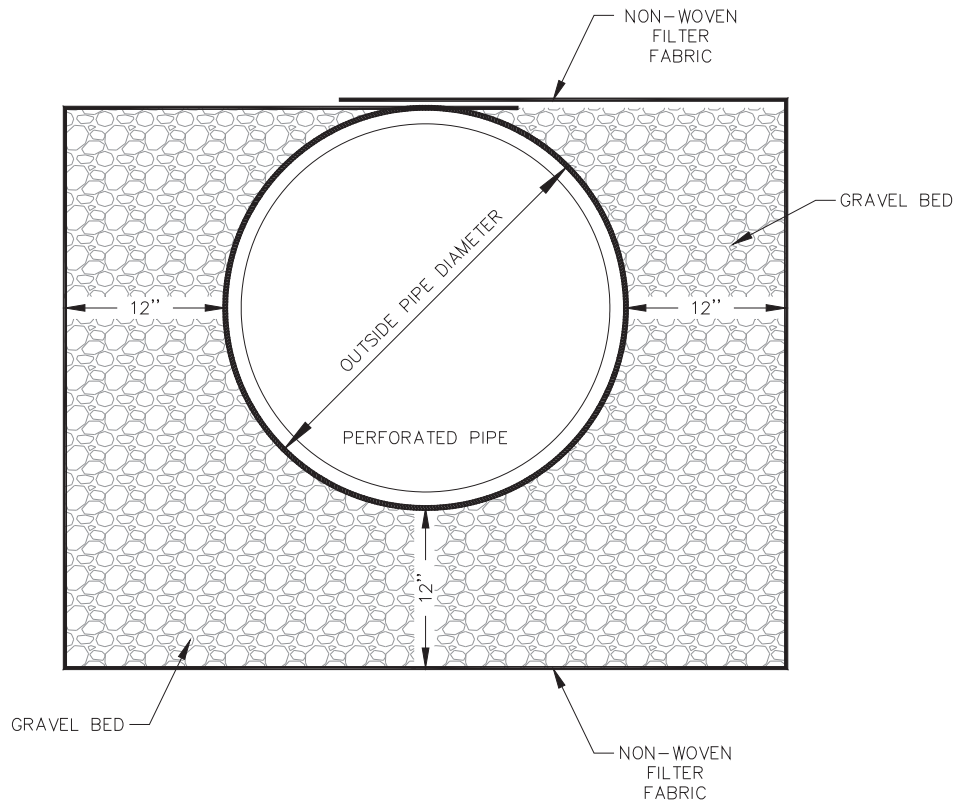

NOTES:

1. THE BOTTOM OF THE PIPE IS REQUIRED TO BE A MINIMUM OF 2' ABOVE THE WATER TABLE.
2. PLASTIC FILTER FABRIC SHALL BE THE NON-WOVEN TYPE AND SHALL COMPLY WITH SECTIONS 514 AND 985 OF THE LATEST EDITION "FLORIDA DEPARTMENT OF TRANSPORTATION SPECIFICATIONS FOR ROAD AND BRIDGE CONSTRUCTION".

City of Fort Walton Beach Engineering Standards	STANDARD UNDERDRAIN EXFILTRATION	SCALE: NTS	6-28-2012 KJN	DRAWING # ESM-4.10
--	----------------------------------	---------------	------------------	-----------------------

Plotted Tuesday, October 18, 2005 11:03:12 AM - C:\Users\KNIITZM-1\FWB\AppData\Local\Temp\ASC7D377864.DWG

Attachment: Engineering Standards Manual Draft (2016 : Approval of the Engineering Standards Manual)

5.00 STREETS

5.01 Street Layout

All streets within the City of Fort Walton Beach shall be designed and constructed to accommodate vehicles, bicycles and pedestrians. The construction of state roads shall be in accordance with the Florida Department of Transportation's (FDOT) Standard Specifications for Road and Bridge Construction and FDOT Design Standards, latest edition. The construction of City streets shall meet the following requirements:

- a. The centerline of all roads shall be centered in the right-of-way. Location of the road may be offset from the right-of-way where the City determines that such changes are needed for adequate traffic capacity, drainage, utilities, pedestrian access or other site constraints.
- b. All travel lanes shall have a minimum lane width of eleven (11) feet measured from the centerline of the road to the edge of pavement. One way streets shall be a minimum of twelve (12) feet in width. Modification to existing City streets shall not result in pavement widths less than ten (10) feet in width.
- c. Off Street Parking may be provided along one or both sides of a City street. Parking lanes shall be the minimum set forth in **Section 6.00**
- d. Bike lanes shall be clearly marked and located between the travel lane and the parking lane or between the travel lane and the edge of pavement. Bike lanes shall be a minimum of four (4) feet in width.
- e. Sidewalks are required along at least one side of all City streets.

5.02 Pavement Design

On streets and roadways within the jurisdiction of the City of Fort Walton Beach, the Engineer of Record is responsible to verify that applicable sound engineering principles are used in the structural design of flexible and rigid pavements systems. Unless otherwise noted, all materials and workmanship shall meet Florida Department of Transportation's Flexible Pavement Design Manual and Standard Specifications for Road and Bridge Construction, latest edition, unless otherwise discussed herein.

- a. The minimum service life of new pavement shall be twenty (20) years, while the minimum service life of rehabilitated pavements shall be ten (10) years.
- b. Road base and subgrade shall be finished and prepared in accordance with Sections 200, 210, 230, 204 and all sections referenced therein of the Florida Department of Transportation Standard Specifications for Road and Bridge Construction, latest edition.
- f. Vehicular surfaces shall be paved with asphalt in accordance with Sections 300, 320, 330, 331 and 916 and all sections referenced therein of the Florida Department of Transportation Standard Specifications for Road and Bridge Construction, latest edition. The City reserves the right to require additional paving or reinforcement depending upon the type and amount of expected vehicular traffic.
- c. For the construction of any new street within the City, the following tests will be provided to the City by the contractor:
 1. Compaction Test for Base Material (where applicable): One (1) for each 500 square yards, but not less than one (1) in each section if the area is less than 500 square yards.

2. Asphalt Testing: One (1) set of the following tests for each 200 tons placed or one (1) set per day if less than 200 tons placed.
 - I. Stability, flow, unit weight, void total percentage total mix, and voids filled shall be determined from set of specimens prepared from each four hours plant operation in accordance with ASTM D 1559 and ASTM D 2726.
 - II. In place density tests will be performed from set (three cored samples) or each four hours plant operation; one half should be obtained at joints.
- d. Match existing curb line with cross slope of 1/4 inch per foot to center line, or as directed by the City.
- e. Hand work may be required in certain areas such as driveways, intersections, storm drains, manholes, etc., to prevent standing water.

5.03 Curb and Gutter

The primary purpose for curbing along City streets is to convey stormwater to inlets, swales, and detention/retention areas. All curbing on streets and roads within the City of Fort Walton shall be a minimum of 3,000 psi concrete. Curb and gutter for City streets shall be of the following type:

- a. Ribbon Curb
- b. Drop Curb
- c. Square back Curb
- d. Rollback Curb

(This section left intentionally blank)

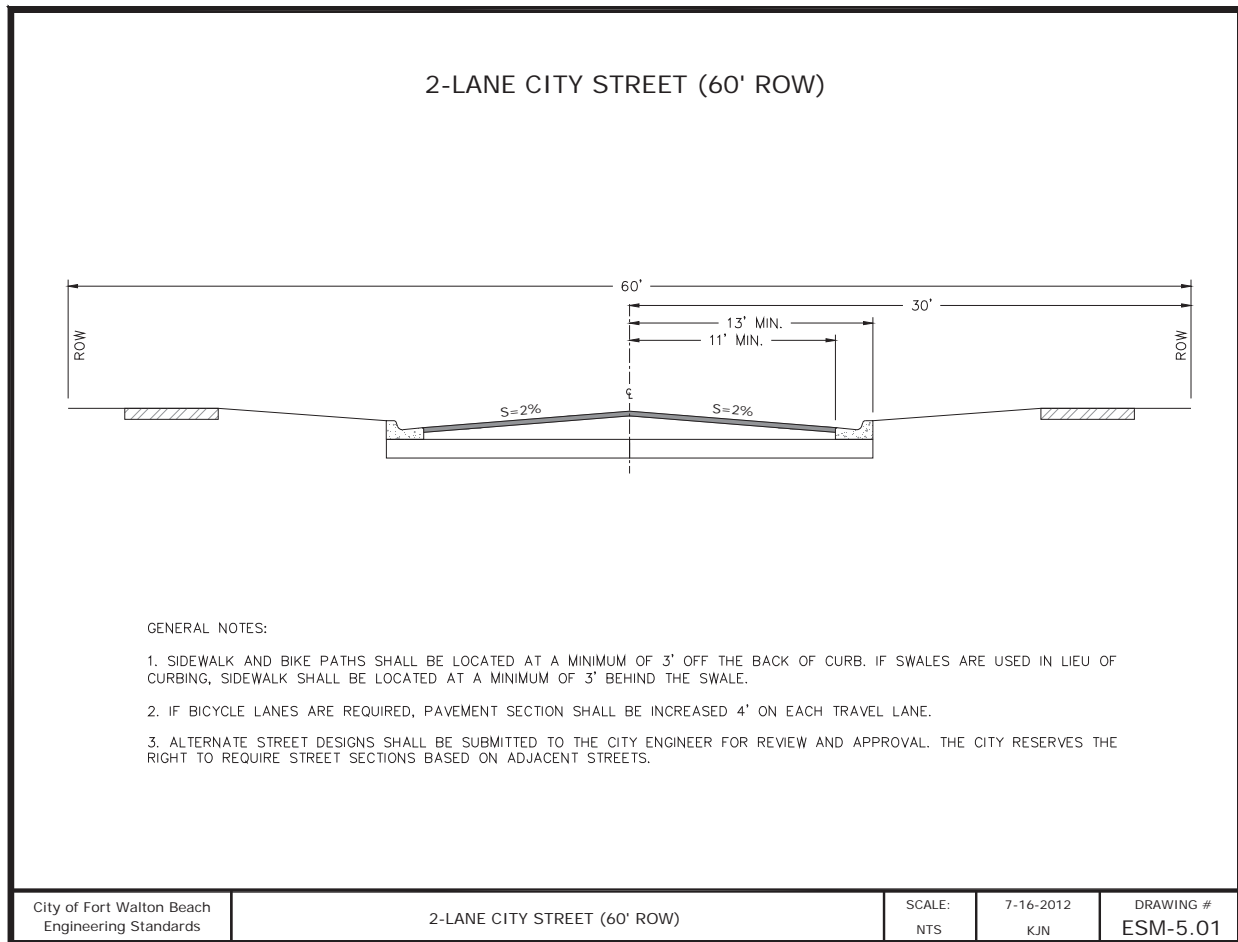

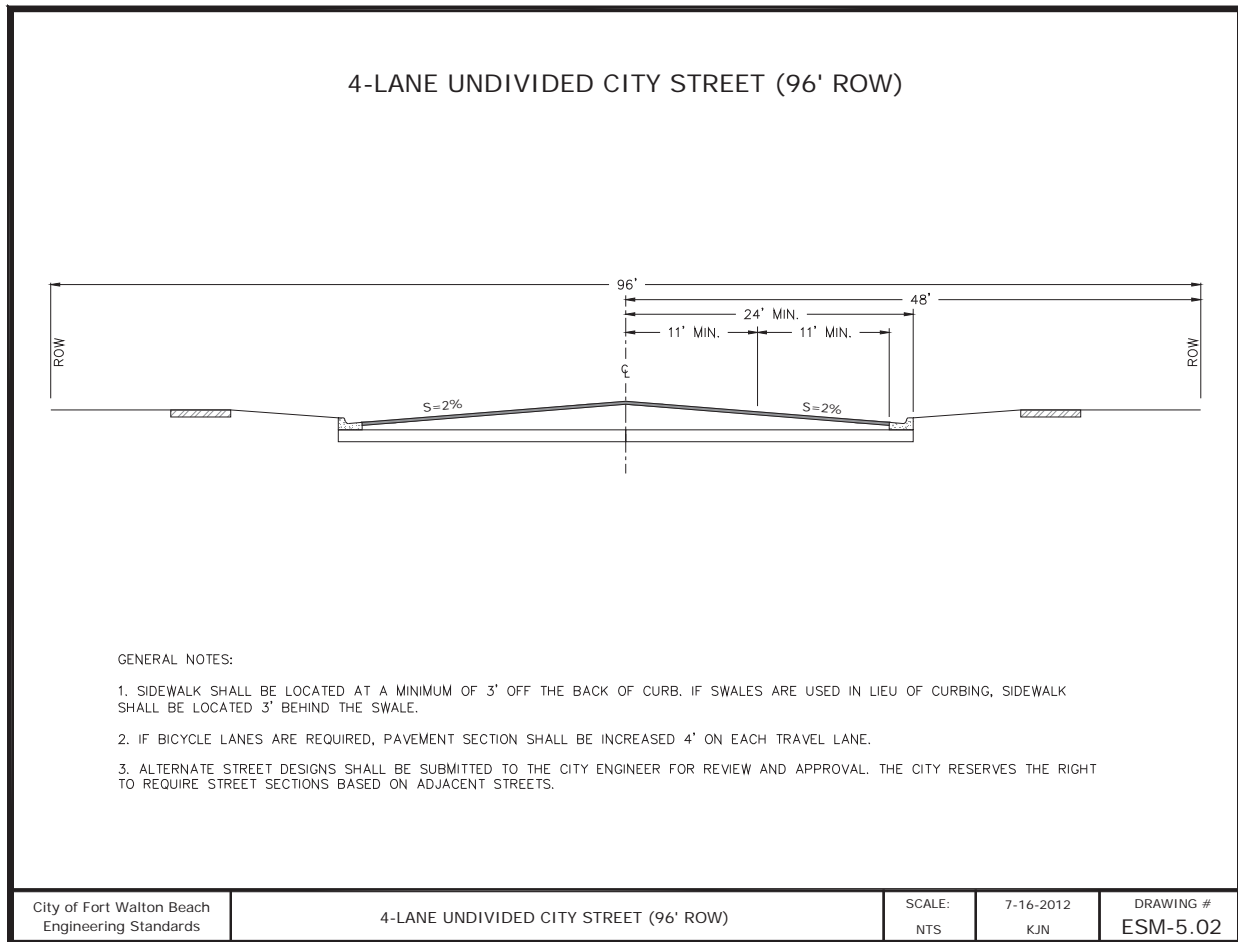

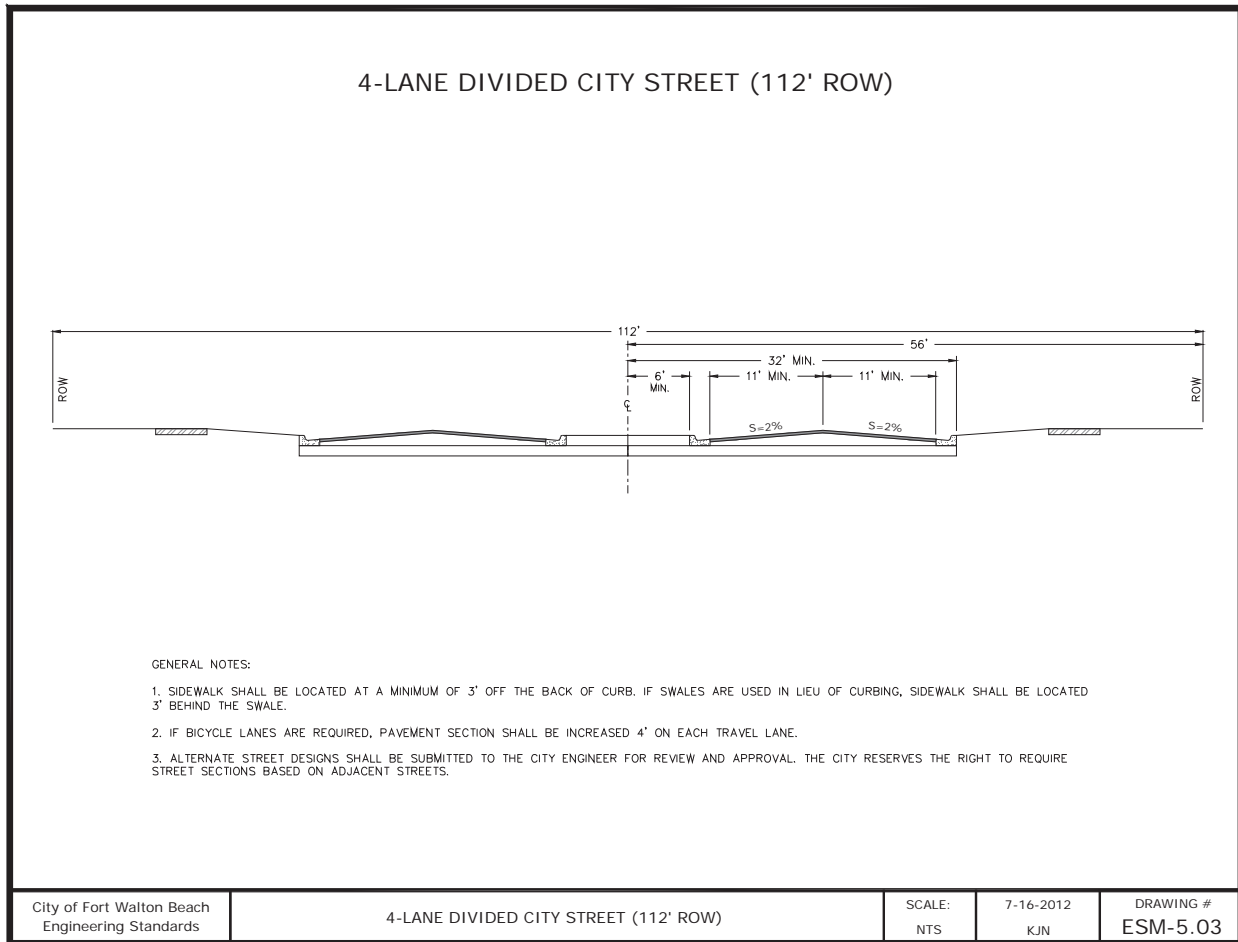

STANDARD CUL-DE-SAC

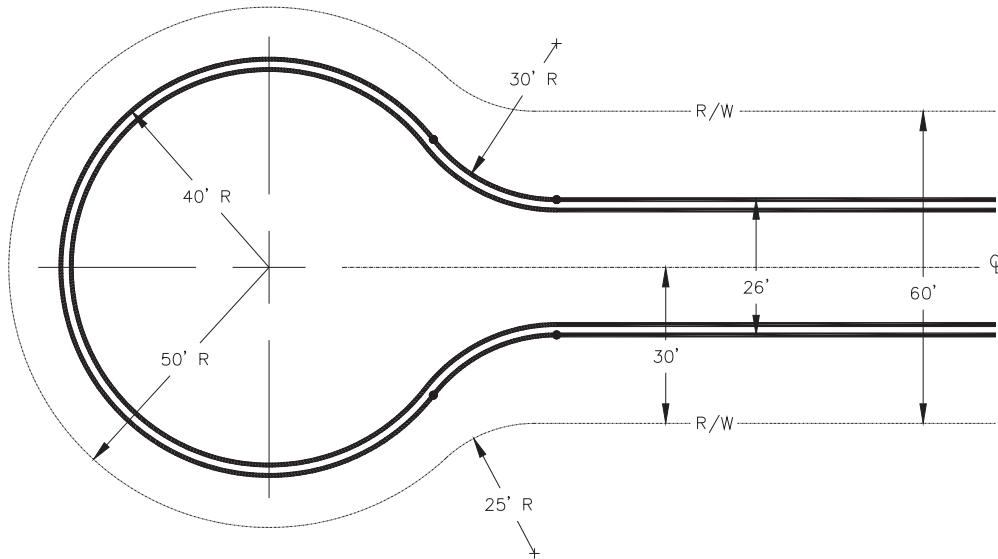

GENERAL NOTES:

1. MAXIMUM STREET LENGTH SHALL BE 400'.
2. CUL-DE-SAC SHALL BE GRADED AWAY FROM THE CENTER.
3. SIDEWALK MAY BE REQUIRED TO EXTEND AROUND CUL-DE-SAC BULB.
4. ALTERNATIVE CUL-DE-SAC DESIGNS, INCLUDING ISLANDS SHALL BE SUBMITTED TO THE CITY ENGINEER FOR REVIEW AND APPROVAL.

City of Fort Walton Beach Engineering Standards	STANDARD CUL-DE-SAC	SCALE: NTS	7-11-2012 KJN	DRAWING # ESM-5.04
--	---------------------	---------------	------------------	-----------------------

Plotted Tuesday, October 18, 2005 11:03:12 AM - C:\Users\KNITZM-1\FWB\AppData\Local\Temp\A5C34C019B9.DWG

Attachment: Engineering Standards Manual Draft (2016 : Approval of the Engineering Standards Manual)

STANDARD OFFSET CUL-DE-SAC

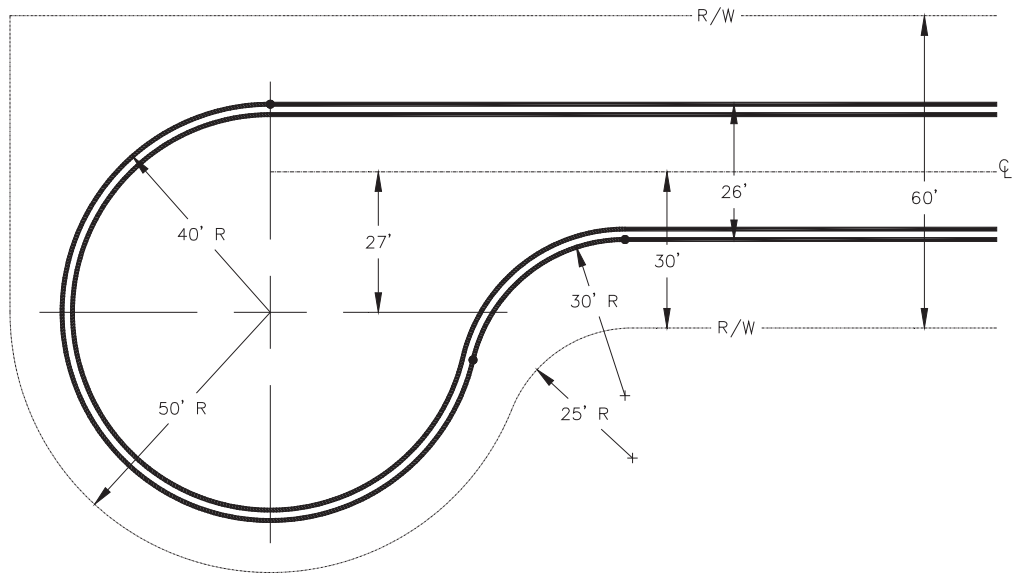

GENERAL NOTES:

1. MAXIMUM STREET LENGTH SHALL BE 400'.
2. CUL-DE-SAC SHALL BE GRADED AWAY FROM THE CENTER.
3. CUL-DE-SAC CAN BE OFFSET, LEFT, RIGHT OR CENTERED.

City of Fort Walton Beach Engineering Standards	STANDARD OFFSET CUL-DE-SAC	SCALE: NTS	7-11-2012 KJN	DRAWING # ESM-5.05
--	----------------------------	---------------	------------------	-----------------------

Plotted Tuesday, October 18, 2005 11:03:12 AM - C:\Users\KNITZM-1\FWB\AppData\Local\Temp\ASC2B7024FC.DWG

Attachment: Engineering Standards Manual Draft (2016 : Approval of the Engineering Standards Manual)

STANDARD T - TURN AROUND

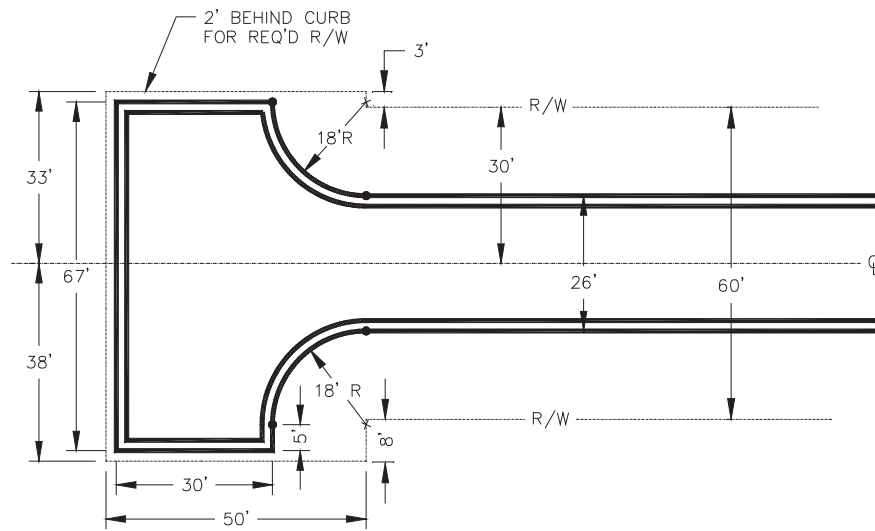

City of Fort Walton Beach Engineering Standards	STANDARD T - TURN AROUND	SCALE: NTS	7-11-2012 KJN	DRAWING # ESM-5.06
--	--------------------------	---------------	------------------	-----------------------

Plotted Tuesday, October 18, 2005 11:03:12 AM - C:\Users\KNITZM-1\FWB\AppData\Local\Temp\ASC18373217.DWG

Attachment: Engineering Standards Manual Draft (2016 : Approval of the Engineering Standards Manual)

STANDARD 2' RIBBON CURB

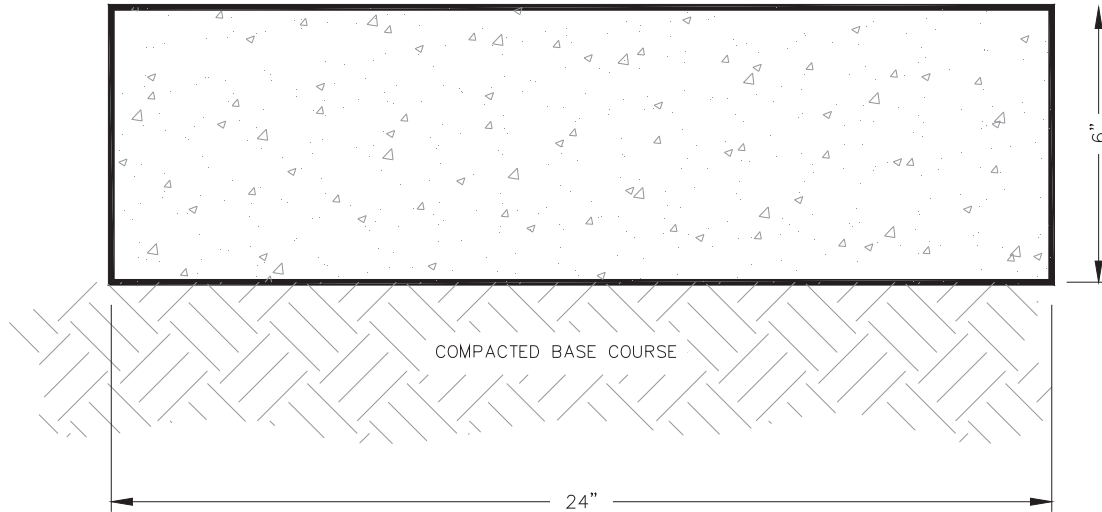

GENERAL NOTES:

1. CURB AND GUTTER CONCRETE SHALL BE PLACED SEPARATELY FROM DRIVEWAY APPROACH AND SIDEWALK.
2. ALL CURB AND COMBINATION CURB AND GUTTER SHALL HAVE CONTROL JOINTS CONSTRUCTED AT 10' INTERVALS AT LEAST ONE HALF INCH IN DEPTH.
3. IT SHALL BE THE CONTRACTORS RESPONSIBILITY TO BACK FILL VOIDS BETWEEN NEW GUTTER AND PAVEMENT WITH CHIPS & DUST OR CITY APPROVED EQUAL AND TO COMPACT SAID BACK FILL WHEN FORMS AND SPOIL ARE REMOVED IN ORDER TO ELIMINATE ANY AND ALL HAZARDS.
4. EXPANSION JOINTS SHALL BE PLACED TO WITHIN 1/4" BELOW THE SURFACE OF THE CONCRETE AND AT INTERVALS OF 30 FEET FOR NEW CONSTRUCTION, WITH CRACK CONTROL JOINTS AT 10 FOOT INTERVALS.
5. EXPANSION JOINTS SHALL BE PLACED WHERE NEW SIDEWALK ABUTS OLD AND BETWEEN CURB & GUTTER AND SIDEWALK.

CONCRETE SHALL BE MINIMUM 3000 P.S.I. STRENGTH.

City of Fort Walton Beach Engineering Standards	STANDARD 2' RIBBON CURB	SCALE: NTS	7-11-2012 KJN	DRAWING # ESM-5.07
--	-------------------------	---------------	------------------	-----------------------

Plotted Tuesday, October 18, 2005 11:03:12 AM - C:\Users\KNITZM-1\FWB\AppData\Local\Temp\ASC698F1B2C.DWG

Attachment: Engineering Standards Manual Draft (2016 : Approval of the Engineering Standards Manual)

STANDARD DROP CURB

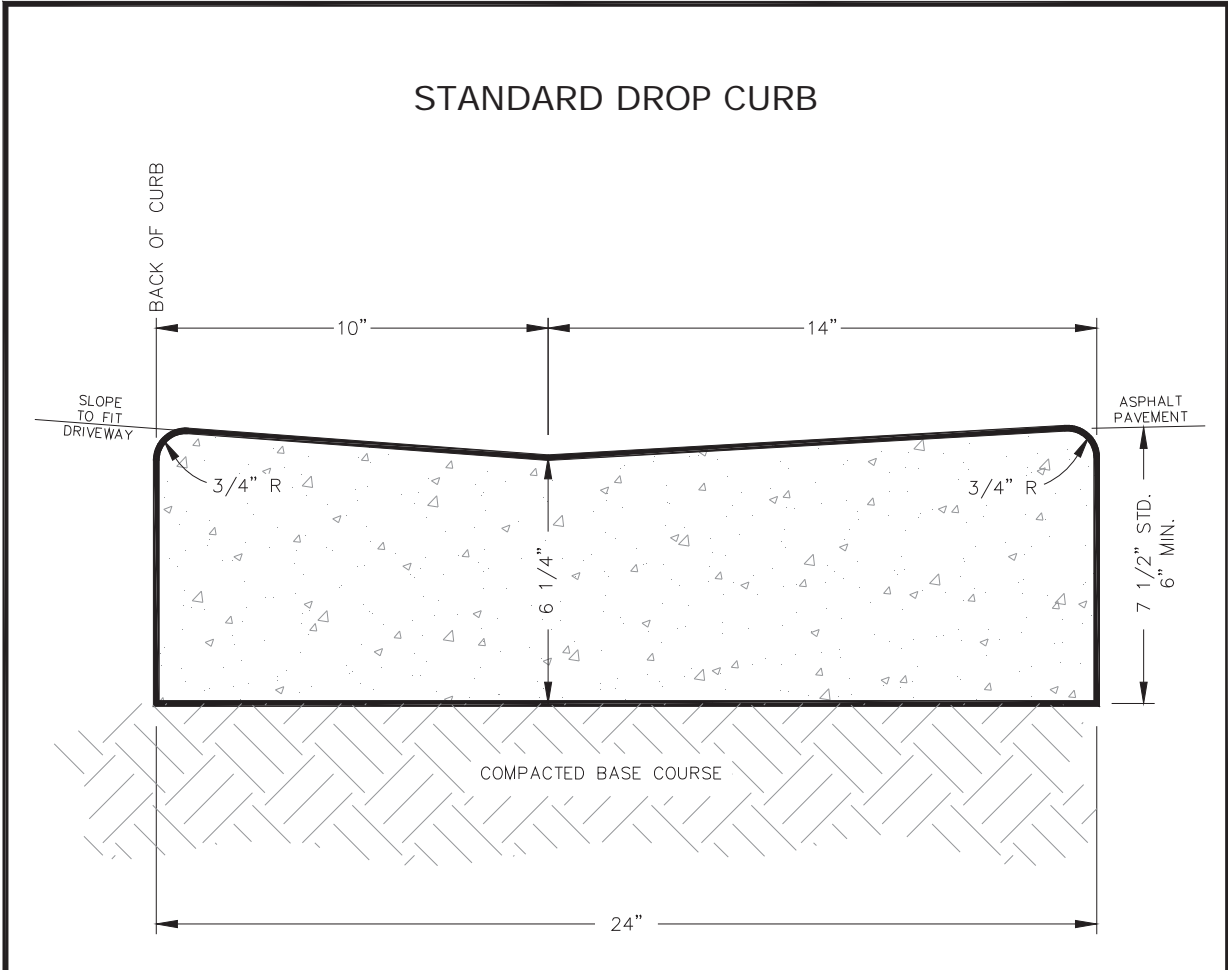

NOTES

1. WHEN USED ON HIGH SIDE OF ROADWAYS, THE CROSS SLOPE OF THE GUTTER SHALL MATCH THE CROSS SLOPE OF THE ADJACENT PAVEMENT AND THE THICKNESS OF THE LIP SHALL BE 6" MIN.
 2. CURB AND GUTTER CONCRETE SHALL BE PLACED SEPARATELY FROM DRIVEWAY APPROACH AND SIDEWALK.
 3. ALL CURB AND COMBINATION CURB AND GUTTER SHALL HAVE CONTROL JOINTS CONSTRUCTED AT 10' INTERVALS AT LEAST ONE HALF INCH IN DEPTH.
 4. IT SHALL BE THE CONTRACTORS RESPONSIBILITY TO BACK FILL VOIDS BETWEEN NEW GUTTER AND PAVEMENT WITH CHIPS & DUST OR CITY APPROVED EQUAL AND TO COMPACT SAID BACK FILL WHEN FORMS AND SPOIL ARE REMOVED IN ORDER TO ELIMINATE ANY AND ALL HAZARDS.
 5. EXPANSION JOINTS SHALL BE PLACED TO WITHIN 1/4" BELOW THE SURFACE OF THE CONCRETE AND AT INTERVALS OF 30 FEET FOR NEW CONSTRUCTION, WITH CRACK CONTROL JOINTS AT 10 FOOT INTERVALS.
 6. EXPANSION JOINTS SHALL BE PLACED WHERE NEW SIDEWALK ABUTS OLD AND BETWEEN CURB & GUTTER AND SIDEWALK.
- CONCRETE SHALL BE MINIMUM 3000 P.S.I. STRENGTH.

City of Fort Walton Beach Engineering Standards	STANDARD DROP CURB	SCALE: NTS	7-11-2012 KJN	DRAWING # ESM-5.08
--	--------------------	---------------	------------------	-----------------------

Plotted Tuesday, October 18, 2005 11:03:12 AM - C:\Users\KNITZM-1\FWB\AppData\Local\Temp\ASc202D7140.DWG

Attachment: Engineering Standards Manual Draft (2016 : Approval of the Engineering Standards Manual)

STANDARD SQUAREBACK CURB

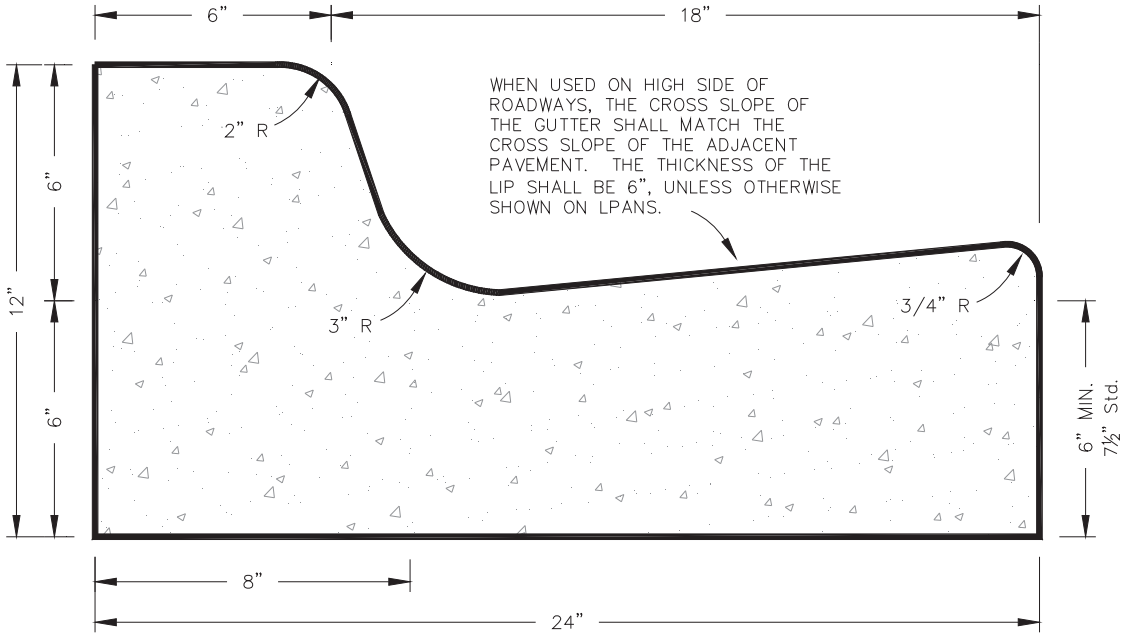

*SEE FDOT INDEX No. 300 TYPE F

GENERAL NOTES:

1. CURB AND GUTTER CONCRETE SHALL BE PLACED SEPARATELY FROM DRIVEWAY APPROACH AND SIDEWALK.
2. ALL CURB AND COMBINATION CURB AND GUTTER SHALL HAVE CONTROL JOINTS CONSTRUCTED AT 10' INTERVALS AT LEAST ONE HALF INCH IN DEPTH.
3. IT SHALL BE THE CONTRACTORS RESPONSIBILITY TO BACK FILL VOIDS BETWEEN NEW GUTTER AND PAVEMENT WITH CHIPS & DUST OR CITY APPROVED EQUAL AND TO COMPACT SAID BACK FILL WHEN FORMS AND SPOIL ARE REMOVED IN ORDER TO ELIMINATE ANY AND ALL HAZARDS.
4. EXPANSION JOINTS SHALL BE PLACED TO WITHIN 1/4" BELOW THE SURFACE OF THE CONCRETE AND AT INTERVALS OF 30 FEET FOR NEW CONSTRUCTION, WITH CRACK CONTROL JOINTS AT 10 FOOT INTERVALS.
5. EXPANSION JOINTS SHALL BE PLACED WHERE NEW SIDEWALK ABUTS OLD AND BETWEEN CURB & GUTTER AND SIDEWALK.

CONCRETE SHALL BE MINIMUM 3000 P.S.I. STRENGTH.

City of Fort Walton Beach Engineering Standards	STANDARD SQUAREBACK CURB	SCALE: NTS	7-11-2012 KJN	DRAWING # ESM-5.09
--	--------------------------	---------------	------------------	-----------------------

Plotted Tuesday, October 18, 2005 11:03:12 AM - C:\Users\KNITZM-1\FWB\AppData\Local\Temp\ASC24D54B3A.DWG

Attachment: Engineering Standards Manual Draft (2016 : Approval of the Engineering Standards Manual)

STANDARD ROLLBACK CURB & GUTTER

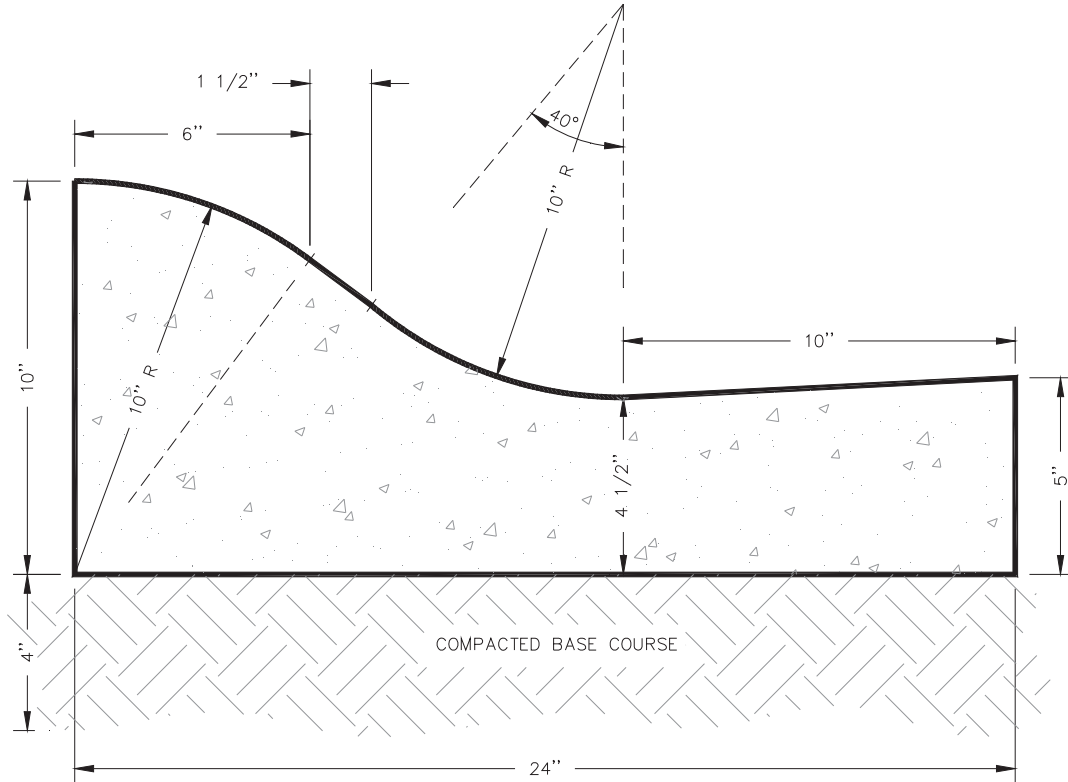

GENERAL NOTES:

1. CURB AND GUTTER CONCRETE SHALL BE PLACED SEPARATELY FROM DRIVEWAY APPROACH AND SIDEWALK.
2. ALL CURB AND COMBINATION CURB AND GUTTER SHALL HAVE CONTROL JOINTS CONSTRUCTED AT 10' INTERVALS AT LEAST ONE HALF INCH IN DEPTH.
3. IT SHALL BE THE CONTRACTORS RESPONSIBILITY TO BACK FILL VOIDS BETWEEN NEW GUTTER AND PAVEMENT WITH CHIPS & DUST OR CITY APPROVED EQUAL AND TO COMPACT SAID BACK FILL WHEN FORMS AND SPOIL ARE REMOVED IN ORDER TO ELIMINATE ANY AND ALL HAZARDS.
4. EXPANSION JOINTS SHALL BE PLACED TO WITHIN 1/4" BELOW THE SURFACE OF THE CONCRETE AND AT INTERVALS OF 30 FEET FOR NEW CONSTRUCTION, WITH CRACK CONTROL JOINTS AT 10 FOOT INTERVALS.
5. EXPANSION JOINTS SHALL BE PLACED WHERE NEW SIDEWALK ABUTS OLD AND BETWEEN CURB & GUTTER AND SIDEWALK.

CONCRETE SHALL BE MINIMUM 3000 P.S.I. STRENGTH.

City of Fort Walton Beach Engineering Standards	STANDARD ROLLBACK CURB & GUTTER	SCALE: NTS	7-11-2012 KJN	DRAWING # ESM-5.10
--	---------------------------------	---------------	------------------	-----------------------

Plotted Tuesday, October 18, 2005 11:03:12 AM - C:\Users\KNITZM-1\FWB\AppData\Local\Temp\AS26B9672F.DWG

Attachment: Engineering Standards Manual Draft (2016 : Approval of the Engineering Standards Manual)

6.00 PARKING AND VEHICULAR ACCESSABILITY

6.01 Off-Street Vehicle Parking

Parking facilities shall be provided for all development within the City unless otherwise noted. The facilities shall be maintained as long as the use exists. Off-street vehicle parking and access drive aisles shall be sized in conformance with following table:

A	B	C	D	E
Parking Angle (degrees)	Stall Width (feet)	Stall Depth (feet)	Aisle Width one-way/two-way (feet)	Minimum Overall Double Row (feet)
Parallel	9.0	22.0	12.0/24.0	30.0
30	9.0	16.8	12.0/24.0	45.6
45	9.0	19.0	13.0/26.0	51.0
60	9.0	21.0	18.0/36.0	60.0
90	9.0	18.0	Na/24.0	60.0

Table 6.1 - Off-Street Vehicle Parking Dimensional Requirements

6.02 Off-Street Vehicle Loading

The standard off-street loading space shall be ten (10) feet wide, twenty-five (25) feet long, and provide a minimum clearance of thirteen (13) feet. The City reserves the right to require longer spaces depending upon the type and amount of expected loading vehicles. Adequate area shall be provided for maneuvering, ingress and egress.

6.03 Bicycle Parking

Bicycle parking shall be provided for all development within the City unless otherwise noted. The facilities shall be maintained as long as the use exists. Construction of bicycle parking shall meet the following requirements:

- Each space shall measure two (2) feet by six (6) feet.
- Each location shall be installed in a permanent manner to resist removal.
- Each location shall not interfere with vehicular or pedestrian movement.

6.04 Parking Lot Design Standards

Parking lots shall be surfaced with gravel, asphalt, concrete, brick pavers or pervious pavers. Signage and striping is required on all parking lots located within the City. The City reserves the right to require additional signage, paving, or reinforcement depending upon the type and amount of expected vehicular traffic.

BICYCLE PARKING

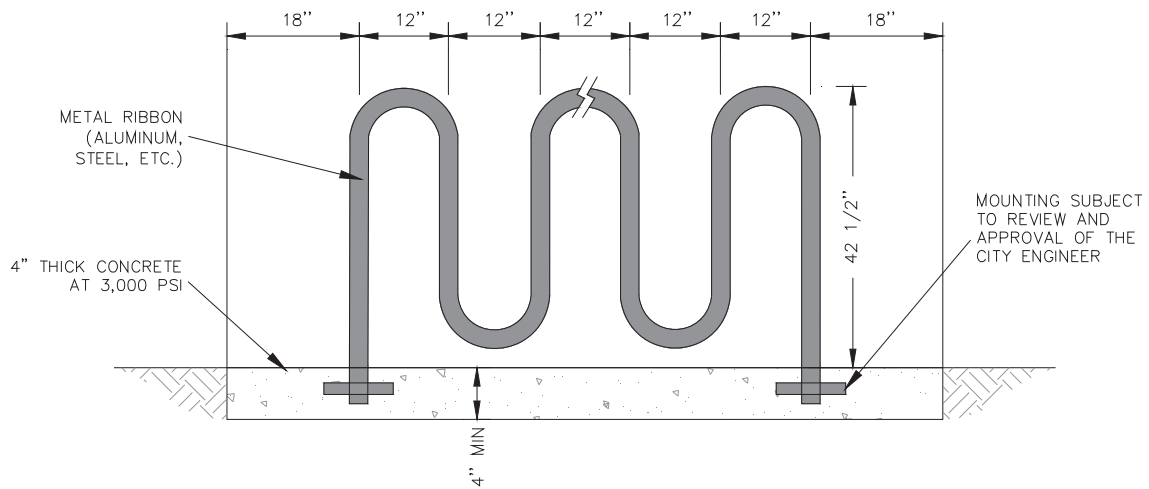

NOTES

1. BICYCLE PARKING SHALL BE LOCATED AS NEAR TO THE PRINCIPLE ENTRANCE OF THE BUILDING AS PRACTICABLE.
2. EACH BICYCLE SPACE SHALL BE A MINIMUM OF 2' WIDE AND 6' LONG.
3. BICYCLE PARKING SHALL BE LOCATED SO AS NOT TO IMPEDE PEDESTRIAN MOVEMENT.

City of Fort Walton Beach Engineering Standards	BICYCLE PARKING	SCALE: NTS	7-11-2012 KJN	DRAWING # ESM-6.01
--	-----------------	---------------	------------------	-----------------------

Plotted Tuesday, October 18, 2005 11:03:12 AM - C:\Users\KNITZM-1\FWB\AppData\Local\Temp\ASC57ED7AE5.DWG

Attachment: Engineering Standards Manual Draft (2016 : Approval of the Engineering Standards Manual)

7.00 SIDEWALKS, MULTI-USE PATHS, AND DRIVEWAYS

7.01 Sidewalk Design Standards

Sidewalks are required on at least one side of all City streets. All Sidewalks constructed within the City of Fort Walton Beach shall be constructed of a minimum of 3,000 psi concrete and shall have a minimum concrete thickness of five (5) inches. Sidewalks located in state road right-of-way shall be in accordance with the Florida Department of Transportation's (FDOT) Standard Specifications for Road and Bridge Construction and FDOT Design Standards, latest edition. The City reserves the right to require a pedestrian/access easement in order to accommodate sidewalks. Construction of City sidewalk shall meet the following requirements:

- d. Subgrade shall be firm and unyielding.
- e. The cross slope for all sidewalks shall not exceed 1:50 (2%).
- f. The longitudinal slope shall not exceed 1:12 (8.33%), with 5 feet x 5 feet landings every 20 feet.
- g. When longitudinal slopes exceed 1:12, an ADA railing and appropriate landings shall be provided.
- h. Minimum clear width around obstacles shall be 36 inches.
- i. Concrete shall be cured a minimum of 24 hours after pouring.
- j. ½ inch deep, tooled control joints shall be provided at a distance equal to the sidewalk width or very 5 feet, whichever is less.
- k. Expansion joints shall be provided at maximum of every fifty (50) feet and where concrete is placed adjacent to existing curbs, driveways, buildings and walkways.

7.02 Multi-Use Path Design Standards

The construction of multi-use paths is encouraged on City streets where bike lanes are not feasible. Multi-use paths shall be designed and constructed to accommodate both pedestrians and cyclists. Multi-use paths constructed within the City of Fort Walton Beach shall be constructed of a minimum of 3,000 psi concrete. Multi-use paths shall have a minimum concrete thickness of five (5) inches. One (1) inch of asphalt may be used as an acceptable alternative to concrete. Construction of City multi-use paths shall conform to the following guidelines:

- a. Subgrade shall be firm and unyielding.
- b. The minimum width for all City multi-use paths shall be eight (8) feet unless otherwise noted.
- c. The cross slope for all multi-use paths shall not exceed 1:50 (2%).
- d. The longitudinal slope shall not exceed 1:12 (8.33%), with 8 feet x 8 feet landings every 20 feet.
- e. When slopes exceed 1:12, an ADA railing and appropriate landings shall be provided.
- f. Minimum clear width around obstacles shall be 36 inches.
- g. Concrete shall be cured a minimum of 24 hours after pouring.
- h. ½ inch deep, tooled control joints shall be provided at a distance equal to the multi-use path width or every 8 feet, whichever is less.
- i. Expansion joints shall be provided at maximum of every fifty (50) feet and where concrete is placed adjacent to existing curbs, driveways, buildings and walkways.

7.03 Driveway Design Standards

All driveways constructed within the City of Fort Walton Beach shall be paved from the edge of pavement to the City right-of-way line. Driveways shall be constructed of a minimum of 3,000 psi concrete or asphalt pavement. Driveways shall have a minimum thickness of five (5) inches for concrete pavements, and a minimum of one and one-half (1 ½) inches for asphalt pavement. Driveways connecting to state road right-of-way shall be in accordance with the Florida Department of Transportation's (FDOT) Standard Specifications for Road and Bridge Construction and FDOT Design Standards, latest edition. The City reserves the right to require additional paving or reinforcement depending upon the type and amount of expected vehicular traffic. Construction of City driveways shall conform to the following guidelines:

- a. Subgrade shall be firm and unyielding.
- b. The maximum width of the driveway shall be twenty-four (24) feet unless the City determines that a wider driveway would provide safer access.
- c. For driveways that intersect City sidewalk, the cross slope of a five (5) foot wide section is to not exceed 1:50 (2%). Longitudinal slope not to exceed 1:12 (8.33%).
- d. Concrete shall be cured a minimum of 24 hours after pouring.
- e. Expansion joints shall be provided where concrete is placed adjacent to the existing curb, driveways, buildings and walkways.
- f. If street has been overlaid into the gutter, match concrete to concrete and asphalt to asphalt.

(This section left intentionally blank)

STANDARD SIDEWALK

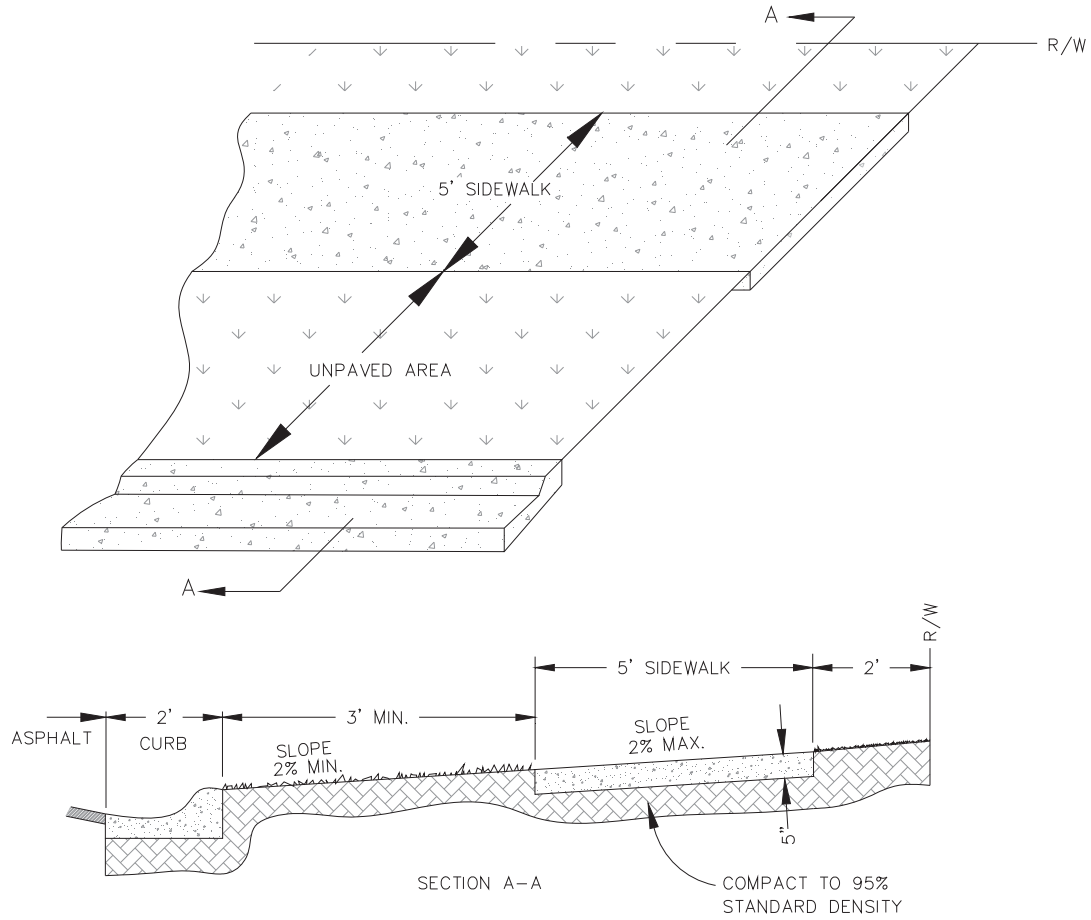

NOTES:

1. CROSS SLOPE NOT TO EXCEED 1:50 (2%).
2. RUNNING SLOPE NOT TO EXCEED 1:12 (8.33%), WITH 5' X 5' LEVEL LANDINGS EVERY 20'
3. MIN. CLEAR WIDTH AROUND OBSTACLES SHALL BE 36 INCHES.
4. WIDTH OF SIDEWALK AS REQUIRED BY ORDINANCE.
5. LOCATION OF SIDEWALK PREFERABLY 2' FROM R/W LINE.
6. SIDEWALK TO BE A MIN. 3,000 PSI CONCRETE.
7. CONCRETE SHALL BE CURED MIN. 24 HOURS AFTER POURING.
8. 1/2" DEEP, TOOLED CONTROL JOINTS SHALL BE PROVIDED AT A DISTANCE EQUAL TO THE SIDEWALK WIDTH OR EVERY 5', WHICHEVER IS LESS.
9. EXPANSION JOINTS SHALL BE PROVIDED AT A MAX. OF 50' AND WHERE CONCRETE IS PLACED ADJACENT TO EXISTING CURB, DRIVEWAYS, BUILDINGS AND WALKWAYS.

City of Fort Walton Beach Engineering Standards	STANDARD SIDEWALK	SCALE: NTS	7-16-2012 KJN	DRAWING # ESM-7.01
--	-------------------	---------------	------------------	-----------------------

Plotted Tuesday, October 18, 2005 11:03:12 AM - C:\Users\KNITZM-1\FWB\AppData\Local\Temp\A5C014D2153.DWG

MULTI-USE PATH

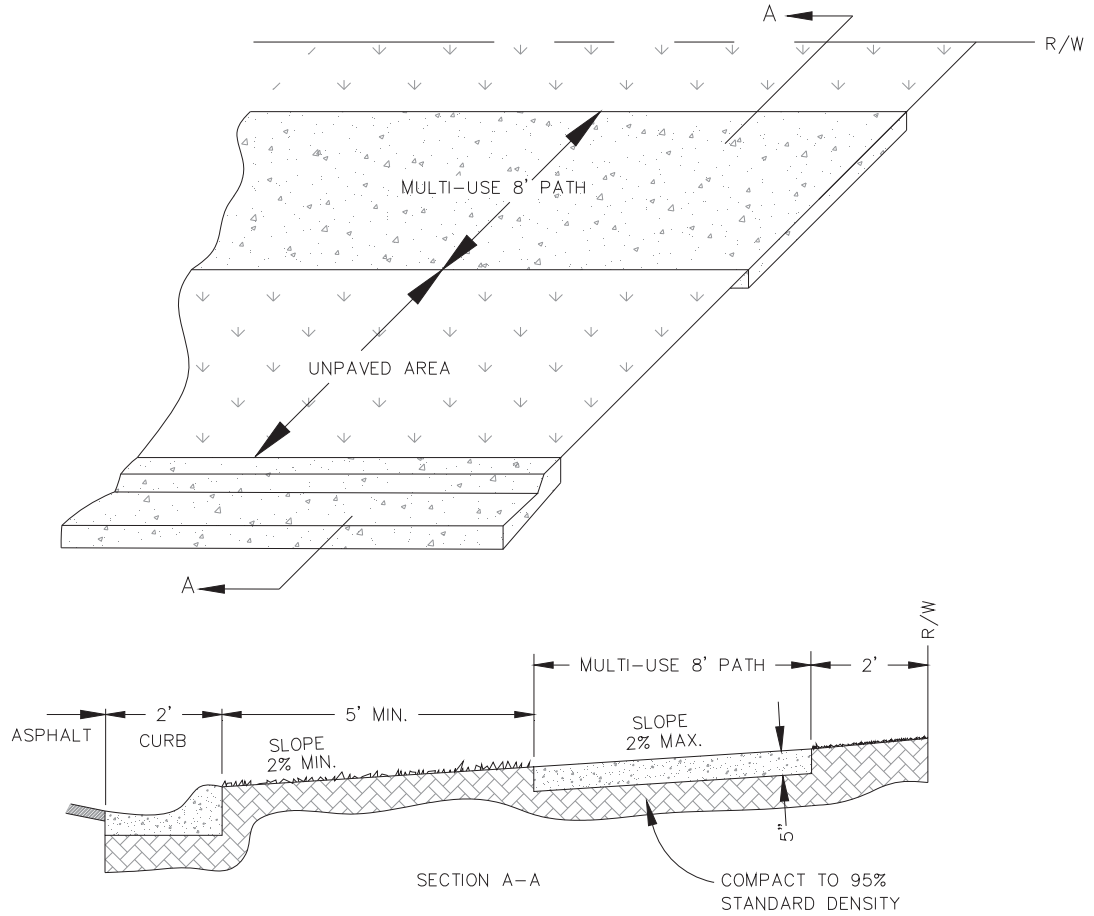

NOTES:

1. CROSS SLOPE NOT TO EXCEED 1:50 (2%).
2. RUNNING SLOPE NOT TO EXCEED 1:12 (8.33%), WITH 8' X 8' LEVEL LANDINGS EVERY 20'
3. MIN. CLEAR WIDTH AROUND OBSTACLES SHALL BE 36 INCHES.
4. LOCATION OF MULTI-USE PATH PREFERABLY 2' FROM R/W LINE.
5. MULTI-USE PATH TO BE A MIN. 3,000 PSI CONCRETE.
6. CONCRETE SHALL BE CURED MIN. 24 HOURS AFTER POURING.
7. 1/2" DEEP, TOOLED CONTROL JOINTS SHALL BE PROVIDED AT A DISTANCE EQUAL TO THE MULTI-USE PATH WIDTH.
8. EXPANSION JOINTS SHALL BE PROVIDED AT A MAX. OF 50' AND WHERE CONCRETE IS PLACED ADJACENT TO EXISTING CURB, DRIVEWAYS, BUILDINGS AND WALKWAYS.

City of Fort Walton Beach Engineering Standards	MULTI-USE PATH	SCALE: NTS	7-16-2012 KJN	DRAWING # ESM-7.02
--	----------------	---------------	------------------	-----------------------

Plotted Tuesday, October 18, 2005 11:03:12 AM · C:\Users\KNITZM-1\FWB\AppData\Local\Temp\ASC67A8769A.DWG

STANDARD RESIDENTIAL DRIVEWAY

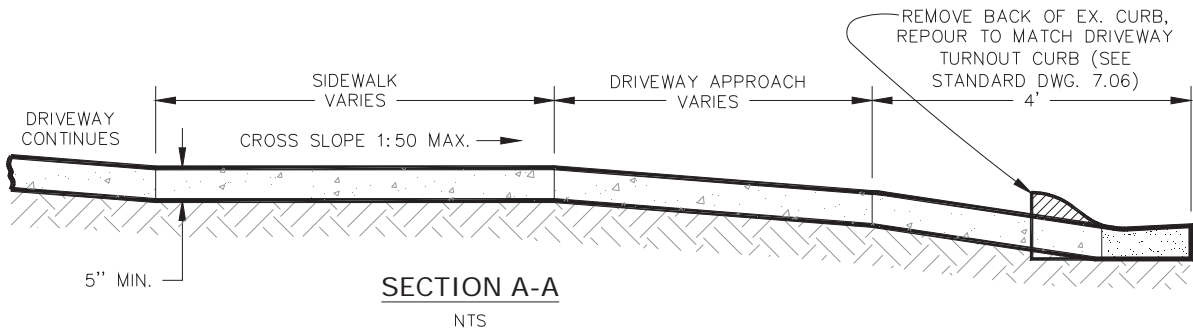
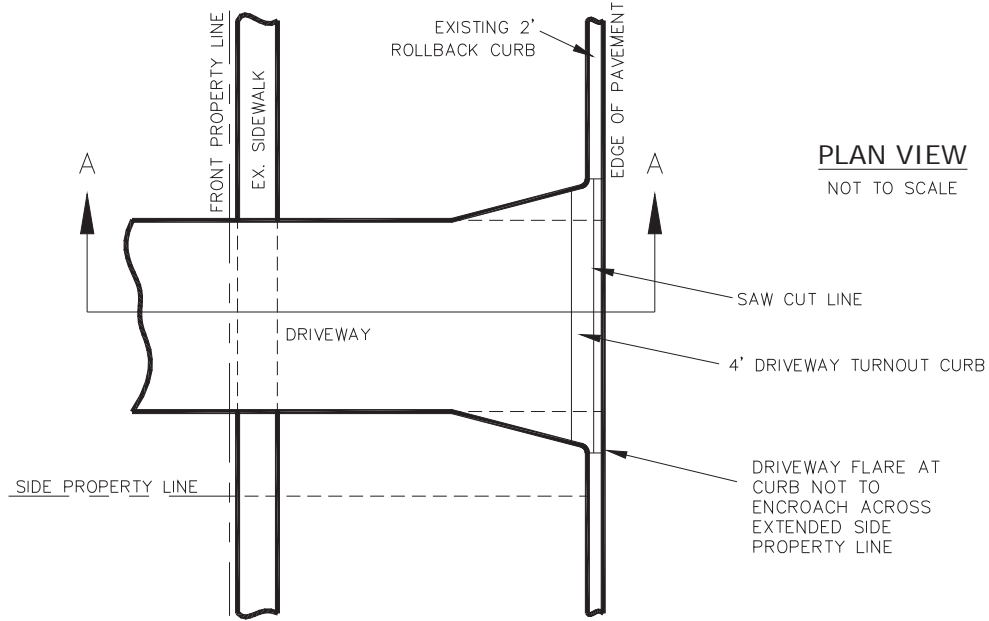

NOTES:

1. CURB TO BE 3000 PSI CONCRETE.
2. MARK CURB AT DESIRED LOCATION AND THE CITY WILL REMOVE THE BACK OF CURB.
3. CALL DEVELOPMENT SERVICES AT 833-9605 AFTER CURB IS MARKED.
4. IF STREET HAS BEEN OVERLAYED, INTO GUTTER, MATCH CONCRETE TO CONCRETE AND ASPHALT TO ASPHALT.

City of Fort Walton Beach Engineering Standards	STANDARD RESIDENTIAL DRIVEWAY	SCALE: NTS	7-16-2012 KJN	DRAWING # ESM-7.03
--	-------------------------------	---------------	------------------	-----------------------

Plotted Tuesday, October 18, 2005 11:03:12 AM - C:\Users\KNITZM~1\FWB\AppData\Local\Temp\ASC11694CE9.DWG

Attachment: Engineering Standards Manual Draft (2016 : Approval of the Engineering Standards Manual)

STANDARD COMMERCIAL DRIVEWAY

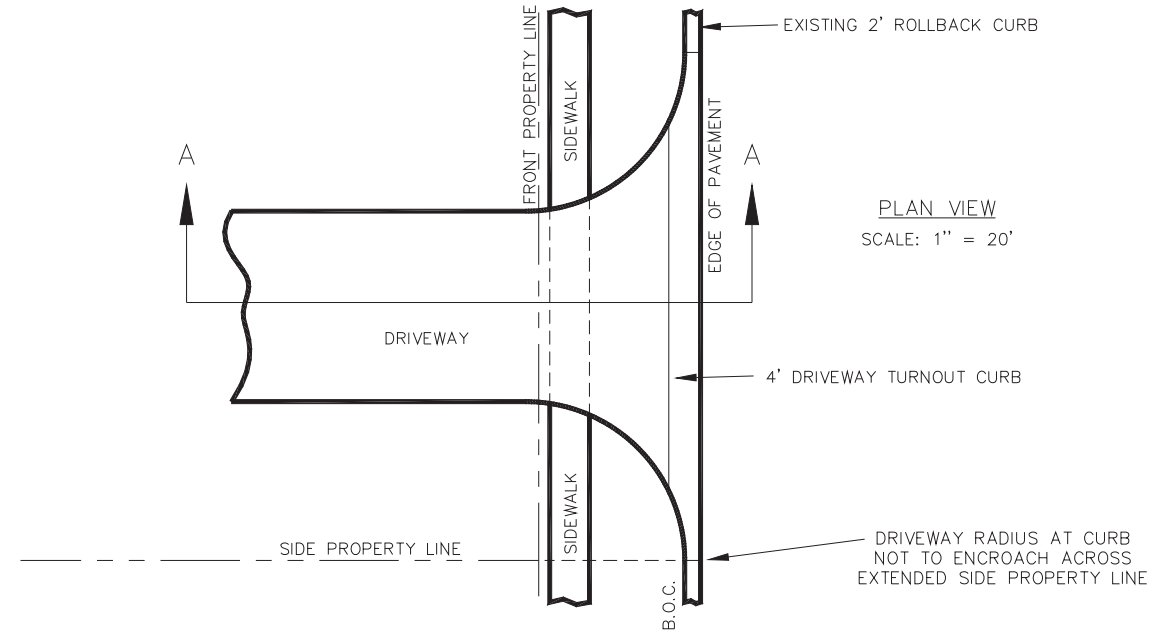

PLAN VIEW
SCALE: 1" = 20'

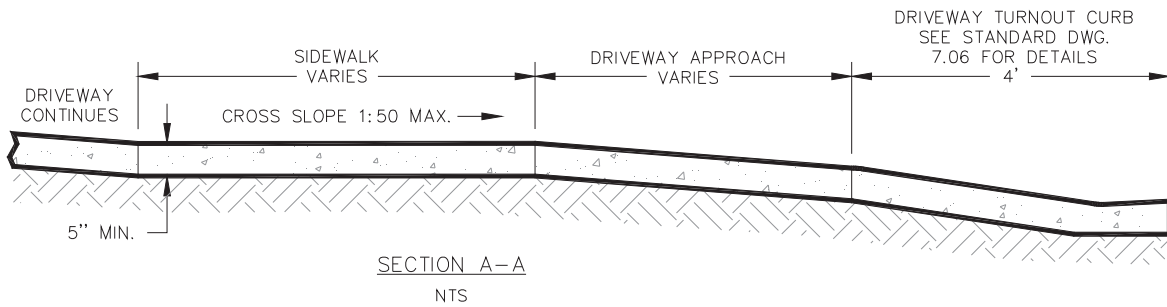

NOTES:

- 1. IF STREET HAS BEEN OVERLAYED, INTO GUTTER, MATCH CONCRETE TO CONCRETE AND ASPHALT TO ASPHALT.
- 2. CURB TO BE 3000 PSI CONCRETE.

City of Fort Walton Beach
Engineering Standards

STANDARD COMMERCIAL DRIVEWAY

SCALE:
NTS

7-16-2012
KJN

DRAWING #
ESM-7.04

Plotted Tuesday, October 18, 2005 11:03:12 AM - C:\Users\KNITZM-1\FWB\AppData\Local\Temp\A5C6DF853C3.DWG

Attachment: Engineering Standards Manual Draft (2016 : Approval of the Engineering Standards Manual)

STANDARD COMMERCIAL DRIVEWAY WITH SIDEWALK AT BACK OF CURB

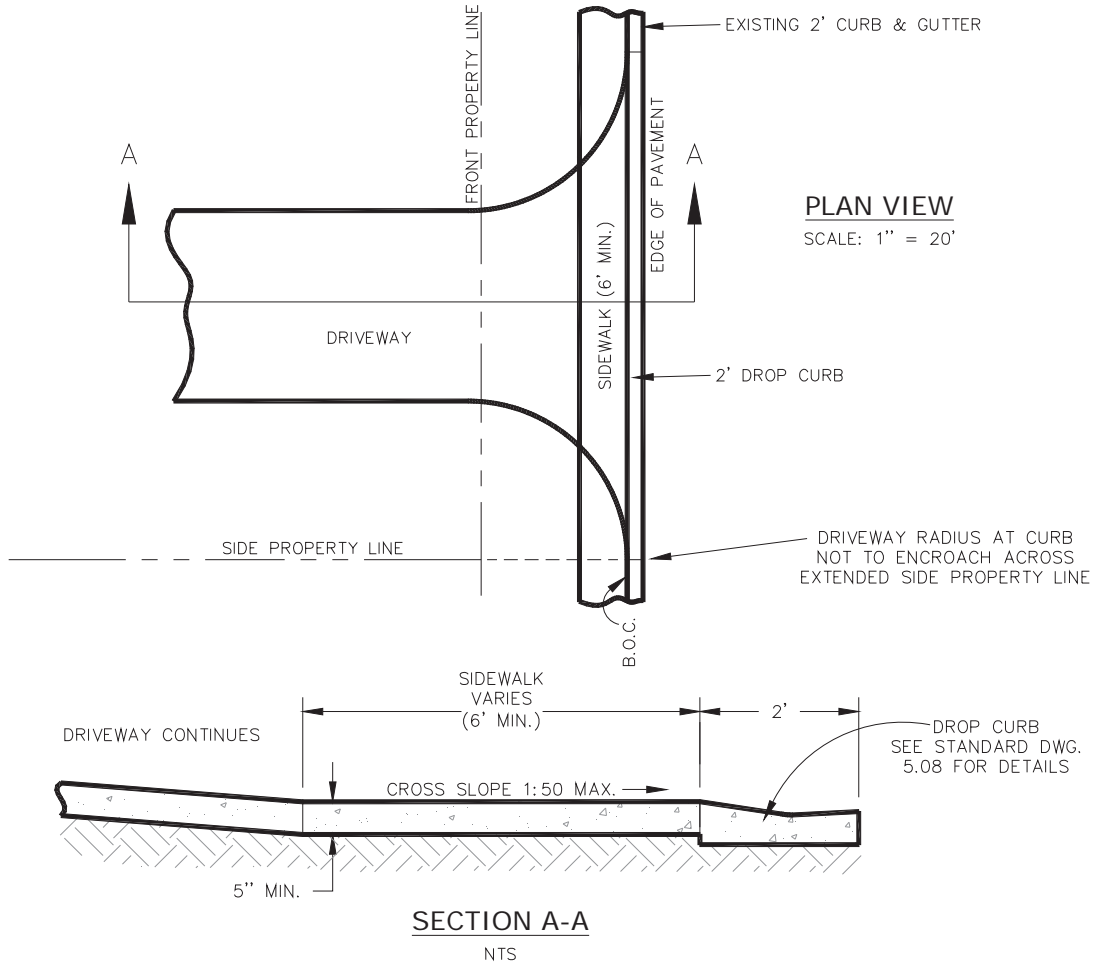

NOTES:

- 1. IF STREET HAS BEEN OVERLAYED, INTO GUTTER, MATCH CONCRETE TO CONCRETE AND ASPHALT TO ASPHALT.

City of Fort Walton Beach Engineering Standards	STANDARD COMMERCIAL DRIVEWAY WITH SIDEWALK AT BACK OF CURB	SCALE: NTS	7-16-2012 KJN	DRAWING # ESM-7.05
--	---	---------------	------------------	-----------------------

Plotted Tuesday, October 18, 2005 11:03:12 AM - C:\Users\KNITZM-1\FWB\AppData\Local\Temp\ASC3064466D.DWG

Attachment: Engineering Standards Manual Draft (2016 : Approval of the Engineering Standards Manual)

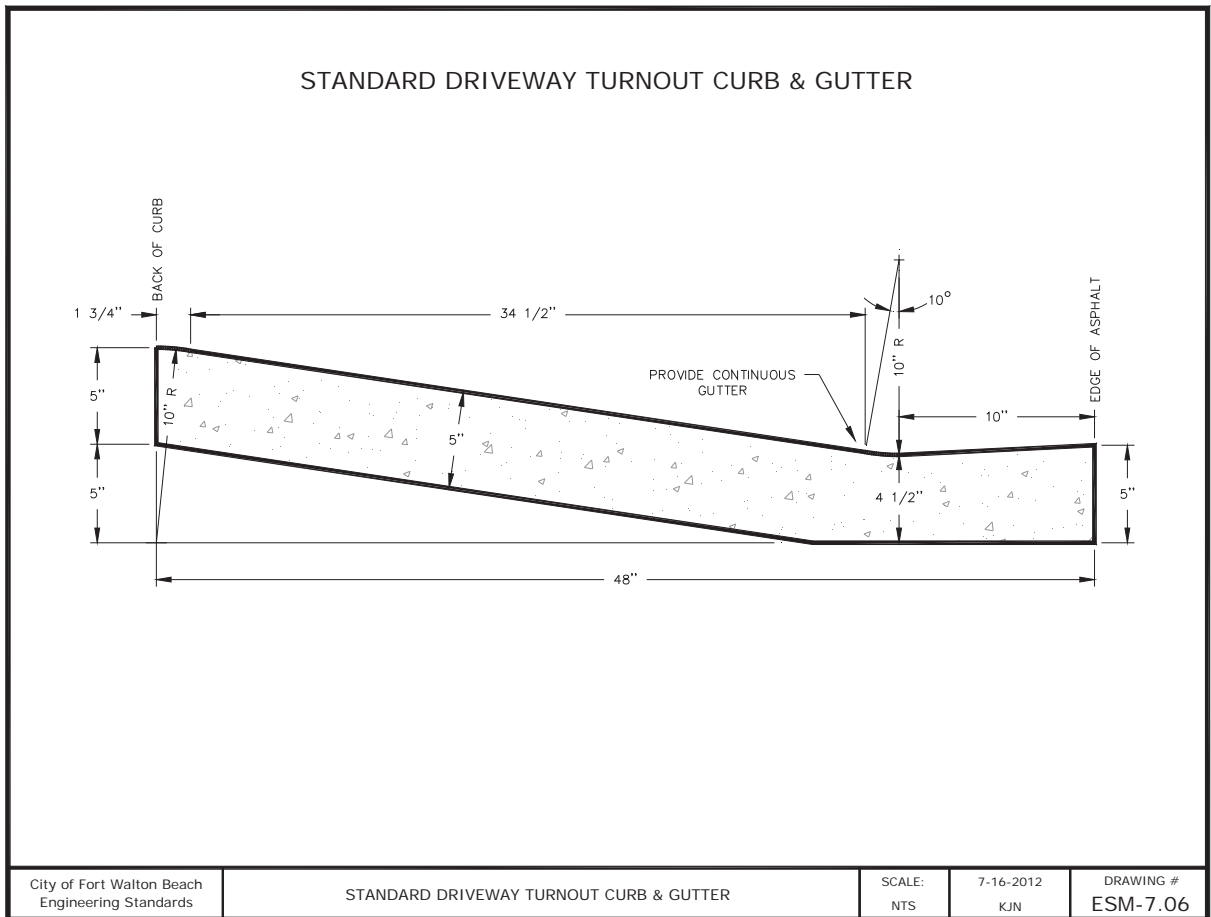

Plotted Tuesday, October 18, 2005 11:03:12 AM - C:\Users\KNITZM-1\FWB\AppData\Local\Temp\ASC075D5449.DWG

8.00 ROADSIDE APPENDITURES

8.01 Solid Waste Receptacle Pads

Solid Waste Receptacles shall be located in an accessible area determined by the City of Fort Walton Beach's Sanitation Department. Receptacle pads constructed within the City shall be constructed of a minimum of 3,000 psi concrete and shall be a minimum of six (6) inches thick. Solid waste receptacle pads and enclosures shall conform to the following requirements:

- a. Subgrade shall be firm and unyielding.
- b. Concrete shall be cured a minimum of 24 hours after pouring.
- c. Expansion joints shall be provided where concrete is placed adjacent to the existing curb, driveways, buildings and walkways.
- d. All receptacles shall be screened from the street.
- e. Gate clearance for the dumpster to be no less than 10'-6".

(This section left intentionally blank)

STANDARD CONCRETE DUMPSTER PAD

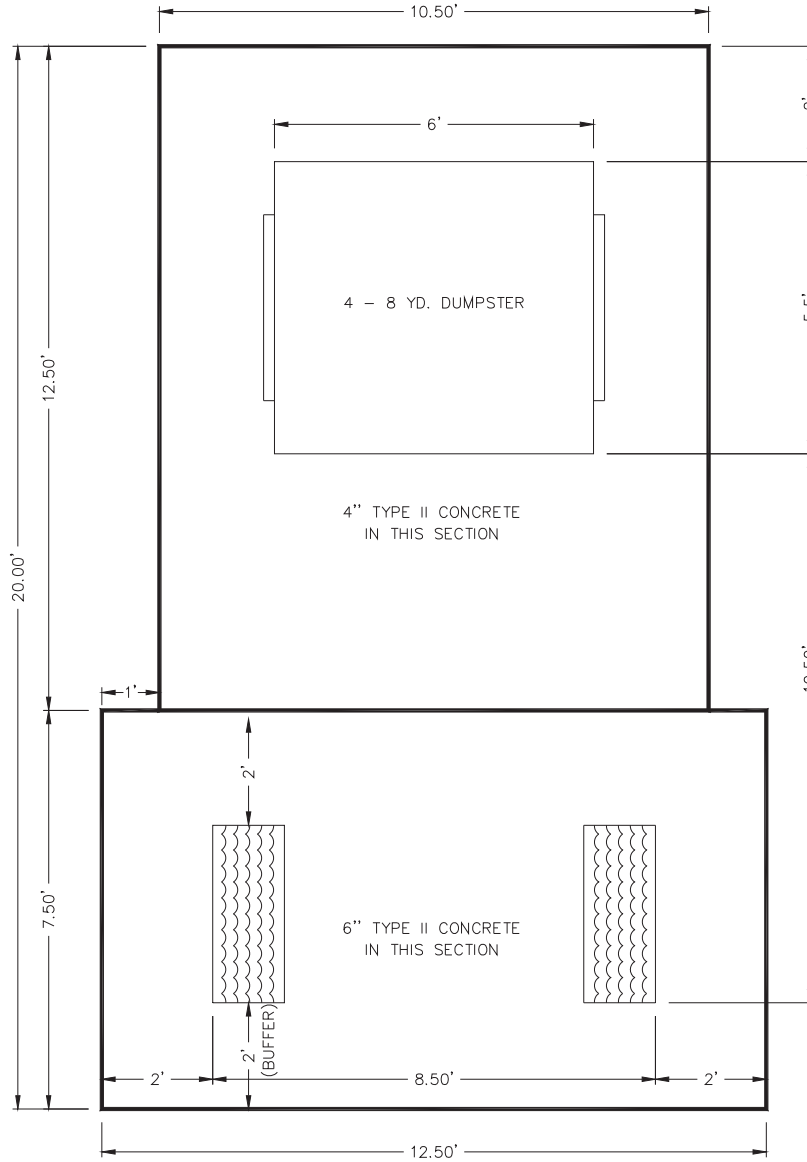

NOTES:

1. DIMENSIONS ARE MINIMUM INSIDE MEASUREMENTS.
2. DUMPSTER TO BE SCREENED FROM THE STREET. GATE CLEARANCE FOR DUMPSTER TO BE NO LESS THAN 10'-6".
3. RECOMMENDED SIZE OF PAD TO AVOID RUTS IN ASPHALT FROM FRONT TIRES OF TRUCK. CITY WILL NOT BE RESPONSIBLE FOR RUTS IN UNDER-DESIGNED SURFACE.

City of Fort Walton Beach
Engineering Standards

STANDARD CONCRETE DUMPSTER PAD

SCALE:
NTS

7-16-2012
KJN

DRAWING #
ESM-8.01

Plotted Tuesday, October 18, 2005 11:03:12 AM - C:\Users\KNITZM-1\FWB\AppData\Local\Temp\A5C645E4042.DWG

Attachment: Engineering Standards Manual Draft (2016 : Approval of the Engineering Standards Manual)

9.00 Utilities

9.01 Utility Easements

All potable water, sanitary sewer, drainage, and reclaimed water system improvements shall be constructed within the right-of-way, platted easement, dedicated easement, or on property owned by the City of Fort Walton Beach. The City requires a utility easement for all utilities located outside the City right-of-way that are to be maintained by the City. All utility easements for City infrastructure shall meet the following requirements:

- a. Utility easements on plats shall be marked clearly and referenced from the right-of-way and property lines. Dedication of the platted utility easement shall be shown on the plat and include any and all restrictions.
- b. In circumstances where deeded utility easements are required, a utility easement shall be prepared by a Florida Registered Land Surveyor and shall include a sketch and legal description.
- c. Utility easements shall be for a specific purpose and permanent in nature.
- d. No structures or other physical barriers are permitted within the easement unless otherwise approved by the City of Fort Walton Beach.
- e. Widths of utility easements shall be no less than three (3) times the depth of the pipe or a minimum of ten (10) feet for potable water, sanitary sewer, drainage and reclaimed water. The City reserves the right to request a larger utility easement depending on the proposed pipe depth, physical constraints, and environmental conditions.

9.02 Potable Water

All potable water lines constructed within the City of Fort Walton Beach shall be installed with a minimum vertical cover of thirty (30) inches. Potable water lines shall be located at least ten (10) feet horizontally away from sanitary sewer or reclaimed water or current FDEP standards. Where crossing under sanitary sewer, potable water lines shall have at least eighteen (18) inches of vertical separation. In situations where vertical and/or horizontal clearances are not met, the main shall be encased in concrete. Construction of potable water lines shall meet the following specifications listed below and in **Appendix 9A..**

- a. Pipe: All pipe used for the water distribution system shall be of the PVC (C900) or ductile iron variety.
 1. Polyvinyl Chloride pipe shall meet the requirements set forth in AWWA C900 and shall be cell class 12454 per ASTM D1784. Plastic pipe and fittings shall bear the seal of the National Sanitation Foundation (NSF) for potable water service.
 2. Ductile iron pipe shall meet the requirements set forth in AWWA C150 and C151.
- b. Fittings: All fittings shall be ductile iron and meet the requirements set forth in AWWA C110, C111, and C153. Fittings shall be complete with gaskets, follower glands, alloy steel tee bolts and hex nuts. Retainer glands shall be made of ductile iron and shall meet the requirements set forth in ASTM A536. Dimensions of the gland shall be such that it conforms to mechanical joint requirements set forth in AWWA C111 and C153.

- c. Tracer Wire: Detection wire shall be insulated single strand, solid copper with a minimum of 12 AWG. A continuous length of tracer wire shall be wrapped around the length of all nonmetallic pipes.
- d. Valves and Valve Boxes: Valves shall be of the resilient seat type and shall conform to the requirements set forth in AWWA C509 and C515. Openings shall be in the counterclockwise direction. Valve boxes shall be cast iron and of the adjustable variety. A traffic rated valve box shall accompany every valve.
- e. Tapping Sleeves and Tapping Valves:
 - 1. Tapping sleeves shall be of the non-restrainable type and shall have a 17-7 type 304 stainless steel body. All associated hardware shall be stainless steel.
 - 2. Tapping valves shall be of the ductile iron type and meet the requirements set forth in AWWA C509. Valves shall be full port opening to accept shell cutters and shall be provided with an alignment ring.
- f. Corporation Stops: Corporation stops shall be either ground key or ball corporation variety and shall conform to the requirements set forth in AWWA C800.
- g. Service Saddle: Service saddles shall be designed to provide a drip tight connection and made of a corrosion resistant material. All service saddles shall be fitting with a high pressure gasket.
- h. Fire Hydrants: Fire hydrants shall be manufactured by American Cast Iron Pipe Company©. Fire hydrants shall meet the requirements set forth in AWWA C502 and have a three (3) way nozzle with a 5 ¼" Valve.
- i. Services: Water services shall be either of the polyethylene or copper variety. All polyethylene water services shall meet the requirements set forth in AWWA C901 C. All copper tubing shall conform to ASTM B 88-96 and be of the Type K, soft variety.
- j. Meters: Water meters shall be manufactured by Hersey Meter Company©. Water meters size ¾" to 2" shall be of the positive displacement type and shall have drive by read capabilities. Water meters 4" and above shall be of the compound type and shall have drive by capabilities.
- k. Backflow Prevention Devices: All backflow preventers shall meet the requirements set forth in AWWA C510 and C511. Residential backflows shall be of the in ground dual check type. Commercial backflows shall be of the reduced pressure (RPZ) type. All backflows shall be located on the customer side of the meter and are the responsibility of the owner.

9.03 Sanitary Sewer

All sanitary sewer components constructed within the City of Fort Walton Beach shall be located in the center of the road. The minimum horizontal clearance between water and sewer lines shall be ten (10) feet minimum or current FDEP standards. The minimum vertical clearance with a water line shall be eighteen (18) inches or current FDEP standards. Sewer lines shall be located below the water lines. Construction of sanitary sewer components shall meet the following specifications listed below and in **Figure 9.2**.

- a. Pipe: All pipe used for the sanitary sewer system shall be of the PVC (SDR 35) or ductile iron variety.
 - 1. Polyvinyl Chloride gravity sewer pipe shall be of the SDR 35 type and meet the requirements of cell class 12454 per ASTM D1784. Pipe sizes 4" – 15" shall meet the requirements of ASTM D3034. Seals shall meet the requirement set forth in ASTM F477.

2. Ductile iron pipe shall be used for pressurized sanitary sewer systems and meet the requirements set forth in ASTM A-746. Ductile iron pipe shall be push on joint and fittings shall be supplied from the same manufacturer. All pipes shall be protected with a City approved coating.
- b. Fittings: Fittings for gravity sewer pipe shall be plastic and shall conform to requirements set forth in ASTM D2680. Fittings for pressurized pipe shall be ductile iron and meet the requirements set forth in ANSI A21.1.
- c. Precast Manholes: Precast concrete manhole risers, base sections, and tops shall conform to ASTM C478. The minimum compressive strength of the concrete shall be 4,000 psi. Cast-in-place manholes shall not be used unless previously authorized by the City.
- d. Frames, Covers, and Grates: Manhole frames, covers, and gratings shall comply with ASTM A48/A48M and shall be Class 35 gray iron, or Class 35B ductile iron unless otherwise indicated. Manholes in vehicular traffic areas shall be rated for H-20 loading.

9.04 Drainage

Drainage components constructed within the City of Fort Walton Beach shall be installed with a minimum vertical cover of twenty-four (30) inches. The minimum vertical clearance with water and sewer shall be eighteen (18) inches or current FDEP standards. Unless otherwise directed, all stormwater pipe located within the City right-of-way shall be reinforced concrete pipe. Alternate material may be used outside the of the City right-of-way. The use of corrugated metal pipe for drainage purposes is prohibited. Construction of drainage system components shall meet the following specifications listed in **Appendix 9A**.

9.05 Reclaimed Water *(reserved for future use)*

9.06 Utility As-builts

Upon completion of utility installation that the City will maintain, the Contractor shall produce and submit signed and sealed record drawings/as-builts produced by a Florida Registered Land Surveyor. The amount of detail on the record drawings shall include but is not limited to graphic scale, manhole rim and invert elevations, pipe material, pipe size, percent slope, location of appurtenances, and any other information deemed necessary by the City. The acceptance of the record drawings by the City does not release the Contractor from the liability of the construction. The City reserves the right to verify the record drawings/as-builts prior to acceptance.

(This section left intentionally blank)

NUMBERS TO CALL FOR LINE SPOTS AND OTHER UTILITY INFORMATION

THE FOLLOWING UTILITIES ARE LOCATED WITHIN THE RIGHT-OF-WAYS OF
THE CITY OF FORT WALTON BEACH, AND THE OWNERS MAY OR MAY NOT
SUBSCRIBE TO A REGISTERED UNDERGROUND UTILITY PROTECTION SERVICE.

WATER/SEWER – CITY OF FORT WALTON BEACH	(850) 833-9613
OKALOOSA COUNTY	(850) 651-7176
GAS – OKALOOSA COUNTY GAS DISTRICT	(850) 729-4880
TV – COX COMMUNICATIONS	(850) 862-4144
TELEPHONE – CENTURY LINK	(855) 742-6062
A T & T	(800) 778-9140
FIBER – CENTURY LINK	(855) 742-6062
A T & T	(903) 753-3145
COX COMMUNICATIONS	(352) 337-2052
SOUTHERN LIGHT	(251) 259-0807
ELECTRIC – GULF POWER	(800) 778-9140
OKALOOSA COUNTY TRAFFIC	(850) 651-7295

48 HOURS BEFORE YOU DIG
CALL SUNSHINE STATE ONE CALL
1-800-432-4770



City of Fort Walton Beach Engineering Standards	NUMBERS TO CALL FOR LINE SPOTS	SCALE: NTS	10-3-2012 KJN	DRAWING # ESM-9.01
--	--------------------------------	---------------	------------------	-----------------------

Plotted Tuesday, October 18, 2005 11:03:12 AM - C:\Users\KNITZM-1\FWB\AppData\Local\Temp\A5C582D6A42.DWG

Attachment: Engineering Standards Manual Draft (2016 : Approval of the Engineering Standards Manual)

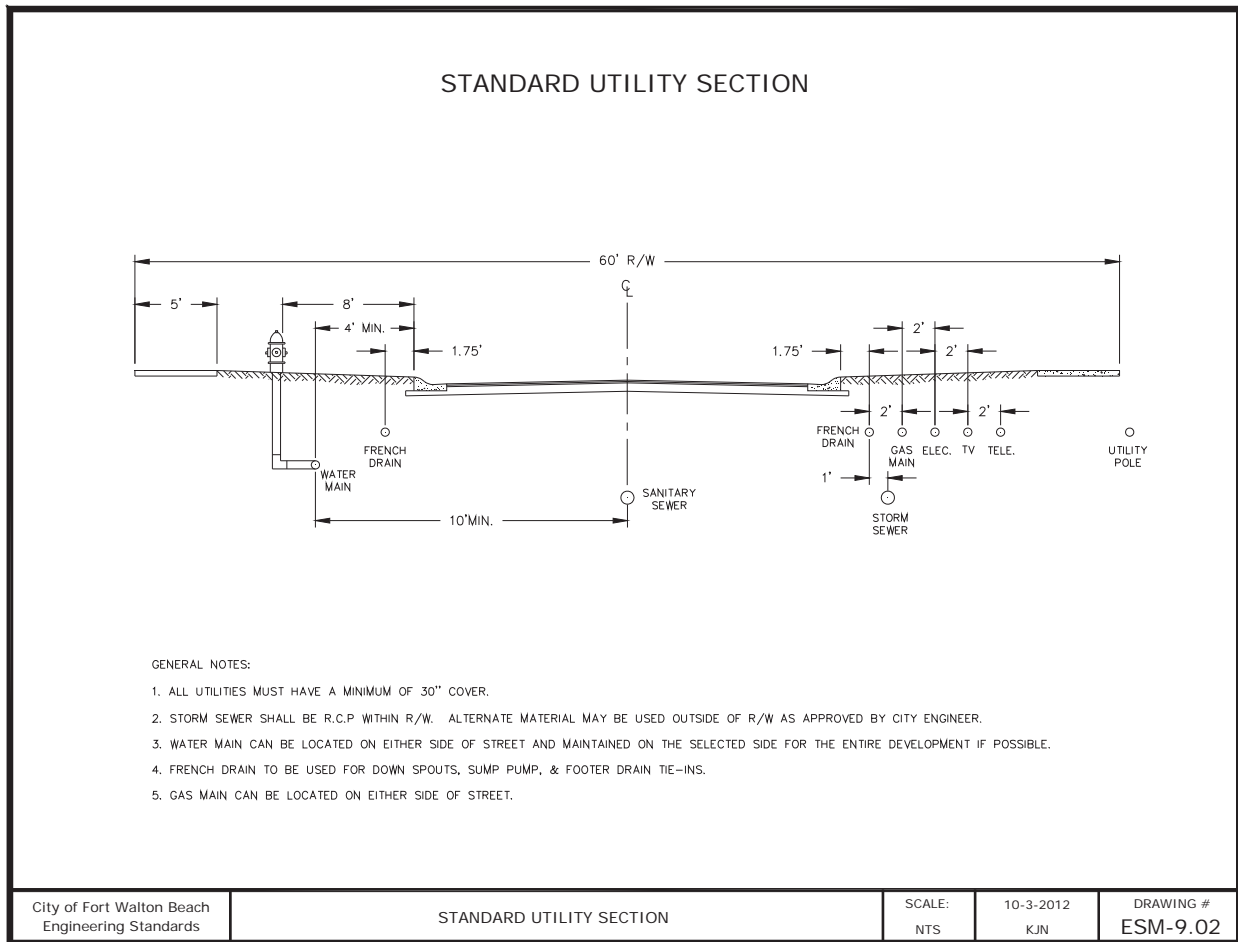

Packet Pg. 264

14.1.a

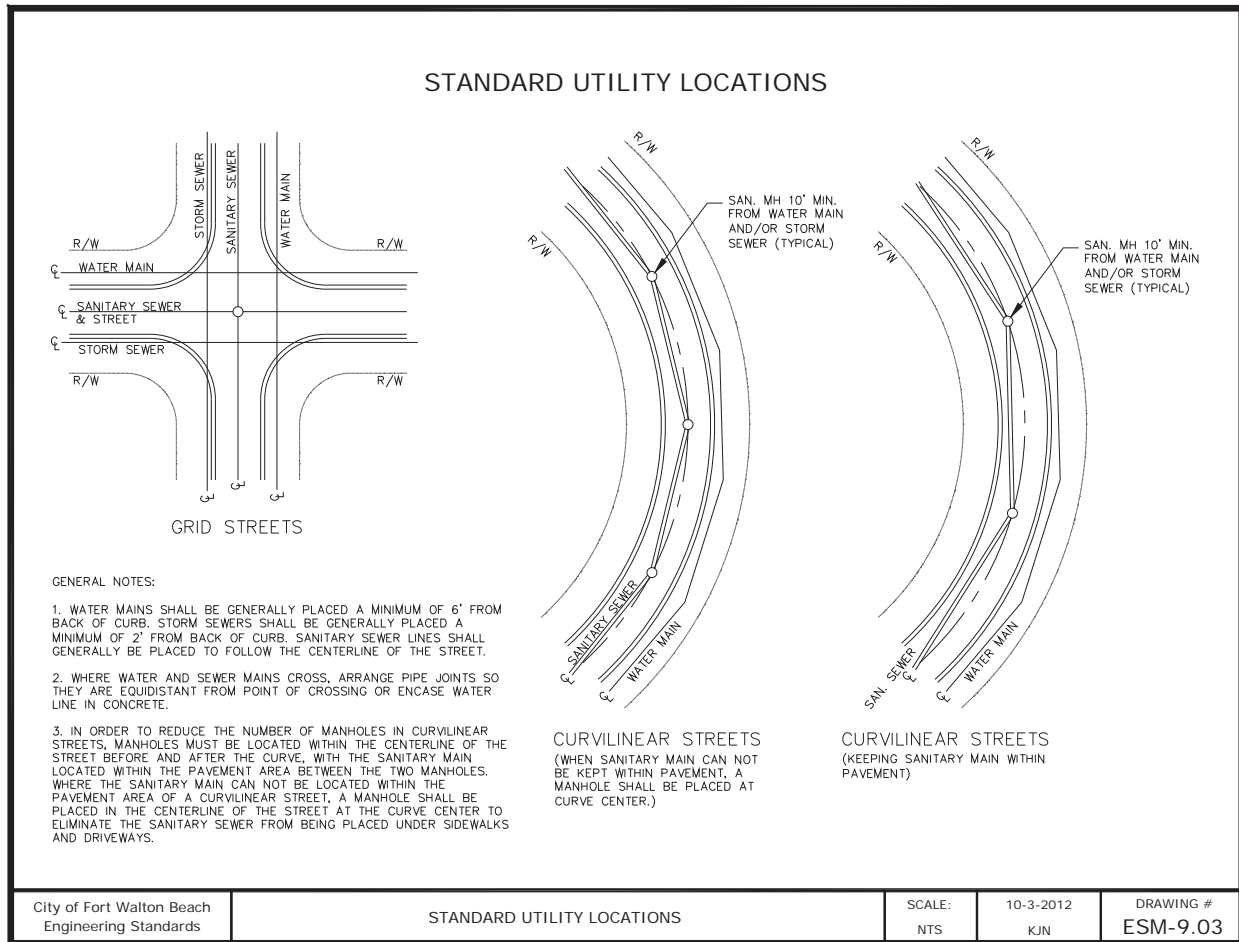

WATER & SEWER MAIN CROSSING/SEPARATION

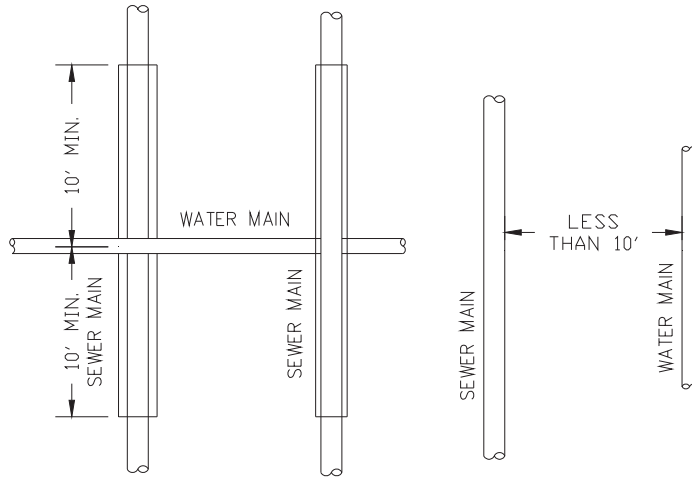

PLAN VIEW

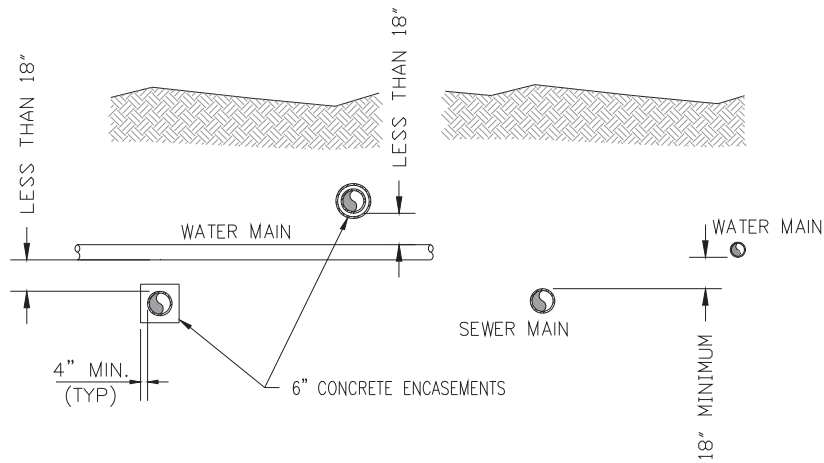

SECTION VIEW

City of Fort Walton Beach Engineering Standards	WATER & SEWER MAIN CROSSING/SEPARATION	SCALE: NTS	10-3-2012 KJN	DRAWING # ESM-9.04
--	---	---------------	------------------	-----------------------

Plotted Tuesday, October 18, 2005 11:03:12 AM - C:\Users\KNITZM-1\FWB\AppData\Local\Temp\ASC115562A0.DWG

Attachment: Engineering Standards Manual Draft (2016 : Approval of the Engineering Standards Manual)

TYPICAL RECLAIMED WATER/POTABLE WATER CROSSING

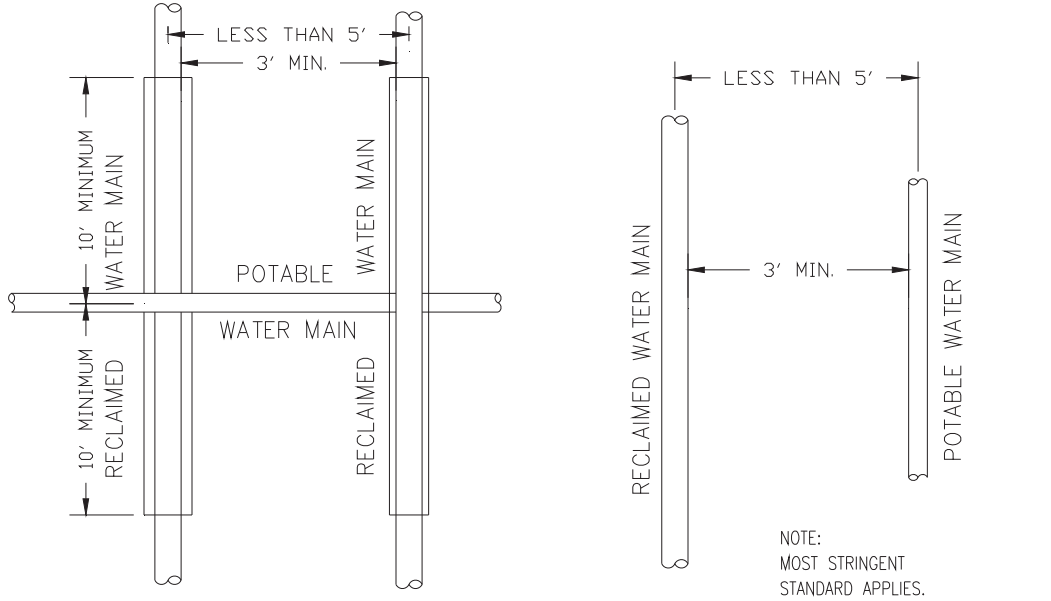

PLAN VIEW

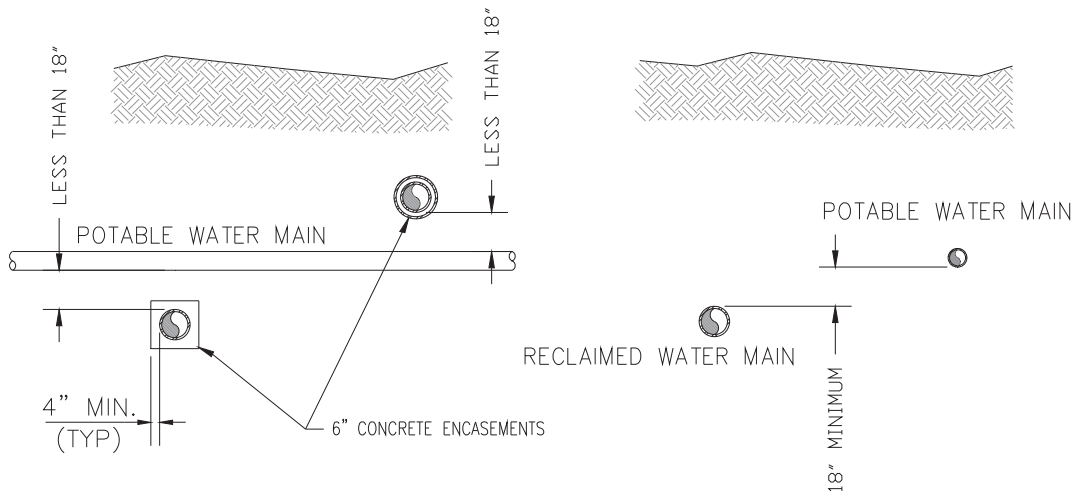

SECTION VIEW

City of Fort Walton Beach
Engineering Standards

TYPICAL RECLAIMED
WATER/POTABLE WATER CROSSING

SCALE:
NTS

10-3-2012
KJN

DRAWING #
ESM-9.05

Plotted Tuesday, October 18, 2005 11:03:12 AM - C:\Users\KNITZM-1\FWB\AppData\Local\Temp\A5C6D24373B.DWG

Attachment: Engineering Standards Manual Draft (2016 : Approval of the Engineering Standards Manual)

CONCRETE ARCH & ENCASEMENT

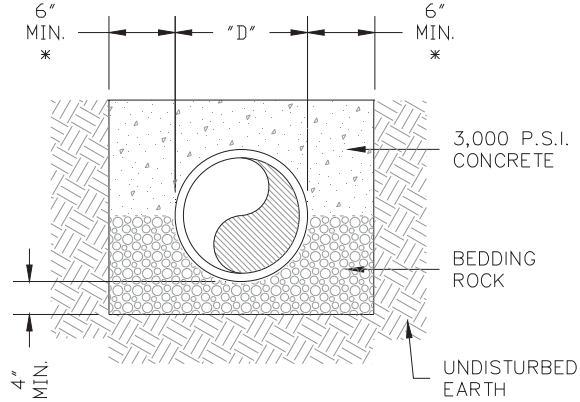

CONCRETE ARCH

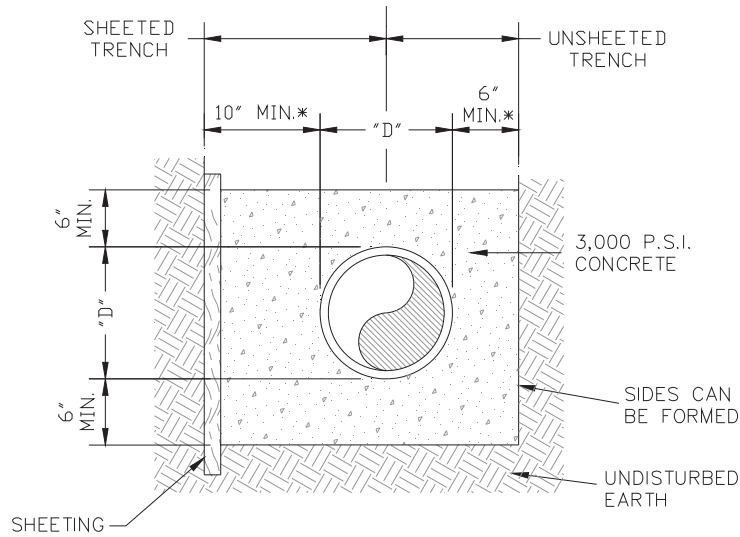

FULL ENCASEMENT

GENERAL NOTES:

1. (*): 15" MAX. FOR PIPE DIAMETER LESS THAN 24", AND 24" MAX. FOR PIPE DIA. 24" AND OVER.
2. "D" REFERS TO THE DIAMETER OF THE PIPE.
3. USE OF CONCRETE ARCH HALF ENCASEMENT OR FULL ENCASEMENT TO BE DETERMINED IN THE FIELD AS DIRECTED BY THE CITY.

City of Fort Walton Beach Engineering Standards	CONCRETE ARCH & ENCASEMENT	SCALE: NTS	10-3-2012 KJN	DRAWING # ESM-9.06
--	----------------------------	---------------	------------------	-----------------------

Plotted Tuesday, October 18, 2005 11:03:12 AM - C:\Users\KNITZM-1\FWB\AppData\Local\Temp\ASC61684BE2.DWG

Attachment: Engineering Standards Manual Draft (2016 : Approval of the Engineering Standards Manual)

STANDARD UTILITY PATCH RESTORATION

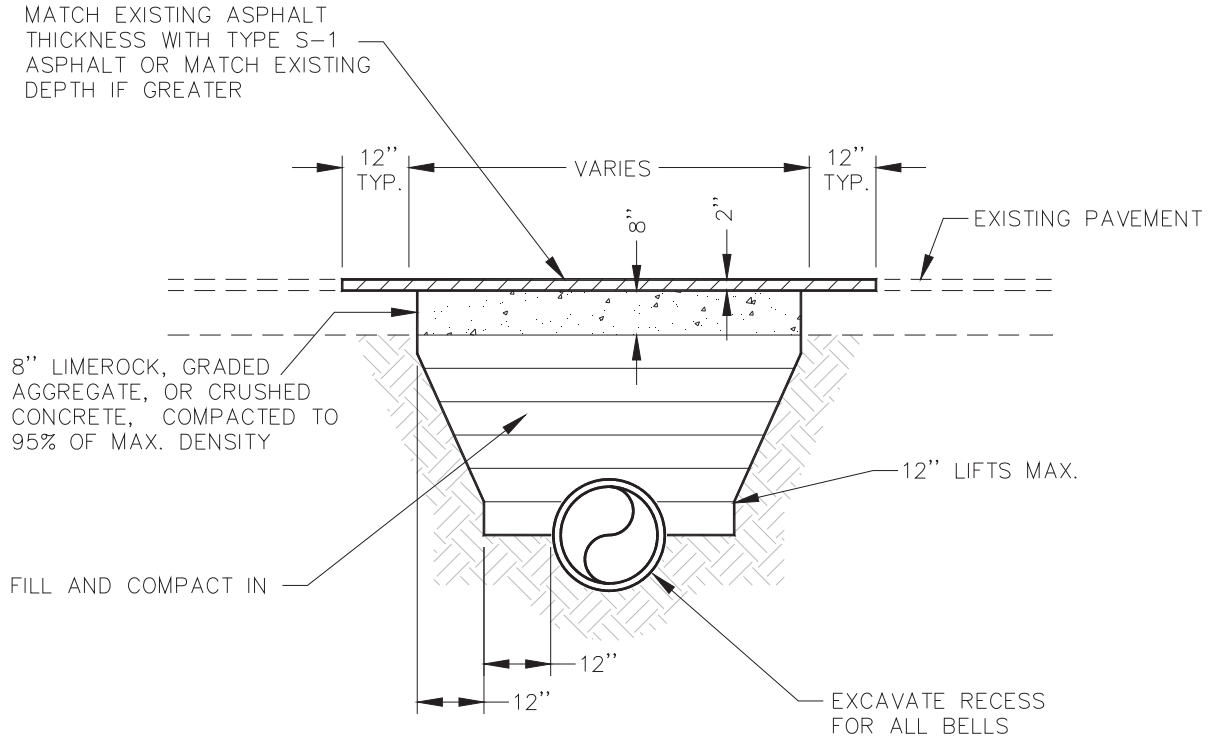

GENERAL NOTES:

1. THE FINAL SAW CUT SHALL BE MADE A DISTANCE OF 12 INCHES BEYOND THE TRENCH, AFTER TRENCH EXCAVATION AND BACKFILL ARE COMPLETE. IF THE DISTANCE FROM THE EDGE OF THE TRENCH TO AN EXISTING BREAK OR JOINT IS LESS THAN 4 FEET, THE FINAL SAW CUT SHALL BE LOCATED AT THE EXISTING BREAK OR JOINT.
2. JOINTS SHALL BE LAPPED AND FEATHERED.

City of Fort Walton Beach Engineering Standards	STANDARD UTILITY PATCH RESTORATION	SCALE: NTS	10-3-2012 KJN	DRAWING # ESM-9.07
--	------------------------------------	---------------	------------------	-----------------------

Plotted Tuesday, October 18, 2005 11:03:12 AM - C:\Users\KNITZM-1\FWB\AppData\Local\Temp\A\$C0A860B5D.DWG

Attachment: Engineering Standards Manual Draft (2016 : Approval of the Engineering Standards Manual)

TRENCH - TYPE "A" BEDDING

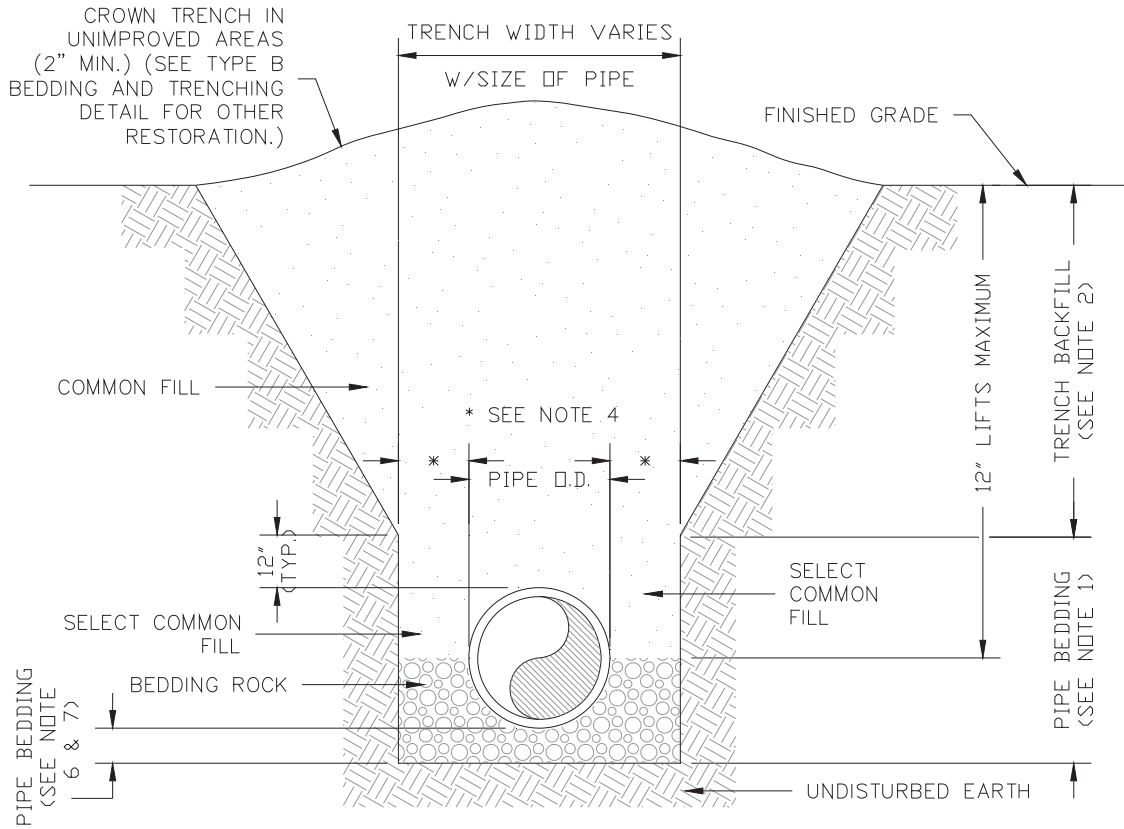

GENERAL NOTES:

1. PIPE BEDDING: SELECT COMMON FILL COMPACTED TO 95% OF THE MAXIMUM DENSITY AS PER AASHTO T-180.
2. TRENCH BACKFILL: COMMON FILL COMPACTED TO 95% OF THE MAXIMUM DENSITY AS PER AASHTO T-180.
3. USE TYPE A BEDDING TO BE DETERMINED IN THE FIELD AS DIRECTED BY THE CITY.
4. (*): 15" MAX. FOR PIPE DIAMETER LESS THAN 24", AND 24" MAX. FOR PIPE DIAMETER 24" AND LARGER.
5. ALL PIPE TO BE INSTALLED WITH BELL FACING UPSTREAM TO THE DIRECTION OF THE FLOW.
6. GRAVITY SEWERS SHALL UTILIZE TYPE A BEDDING, IF REQUIRED BY THE CITY. BEDDING DEPTH SHALL BE 4" MINIMUM FOR PIPE DIAMETER LESS THAN 15", AND 6" MINIMUM PIPE DIAMETER 16" AND LARGER.
7. DEPTH FOR REMOVAL OF UNSUITABLE MATERIAL SHALL GOVERN DEPTH OF BEDDING ROCK BELOW THE PIPE. CITY SHALL DETERMINE IN THE FIELD REQUIRED REMOVAL OF UNSUITABLE MATERIAL TO REACH SUITABLE FOUNDATION.

City of Fort Walton Beach Engineering Standards	TRENCH - TYPE "A" BEDDING	SCALE: NTS	10-3-2012 KJN	DRAWING # ESM-9.08
--	---------------------------	---------------	------------------	-----------------------

Plotted Tuesday, October 18, 2005 11:03:12 AM - C:\Users\KNITZM-1\FWB\AppData\Local\Temp\A\$C044578F4.DWG

TRENCH - TYPE "B" BEDDING

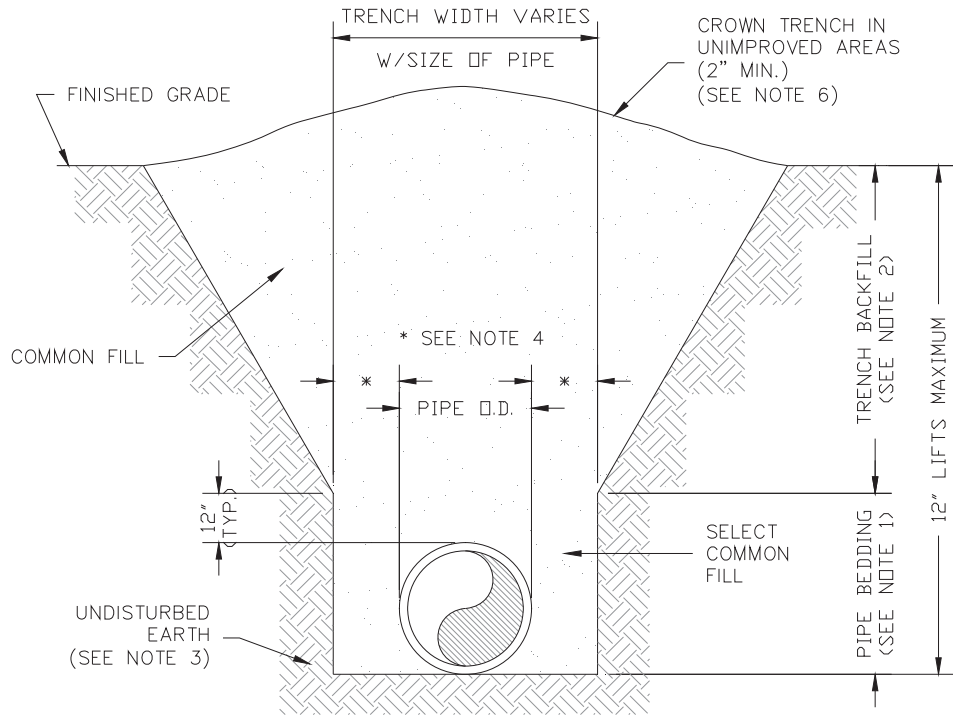

GENERAL NOTES:

1. PIPE BEDDING: SELECT COMMON FILL COMPACTED TO 95% OF THE MAXIMUM DENSITY AS PER AASHTO T-180.
2. TRENCH BACKFILL: COMMON FILL COMPACTED TO 95% OF THE MAXIMUM DENSITY AS PER AASHTO T-180.
3. PIPE BEDDING UTILIZING SELECT COMMON FILL OR BEDDING ROCK IN ACCORDANCE WITH TYPE A BEDDING AND TRENCHING DETAIL MAY BE REQUIRED AS DIRECTED BY THE CITY.
4. (*): 15" MAX. FOR PIPE DIAMETER LESS THAN 24", AND 24" MAX. FOR PIPE DIAMETER 24" AND LARGER.
5. ALL PIPE TO BE INSTALLED WITH BELL FACING UPSTREAM TO THE DIRECTION OF THE FLOW.
6. FINAL RESTORATION IN IMPROVED AREAS SHALL BE IN COMPLIANCE WITH ALL APPLICABLE REGULATIONS OF GOVERNING AGENCIES. SURFACE RESTORATION WITHIN FDOT & CITY RIGHT-OF-WAY SHALL COMPLY WITH REQUIREMENTS OF RIGHT-OF-WAY UTILIZATION REGULATIONS AND ROAD CONSTRUCTION SPECIFICATIONS.

City of Fort Walton Beach Engineering Standards	TRENCH - TYPE "B" BEDDING	SCALE: NTS	10-3-2012 KJN	DRAWING # ESM-9.09
--	---------------------------	---------------	------------------	-----------------------

Plotted Tuesday, October 18, 2005 11:03:12 AM - C:\Users\KNITZM-1\FWB\AppData\Local\Temp\ASC7D2F0508.DWG

Attachment: Engineering Standards Manual Draft (2016 : Approval of the Engineering Standards Manual)

STANDARD THRUST BLOCK

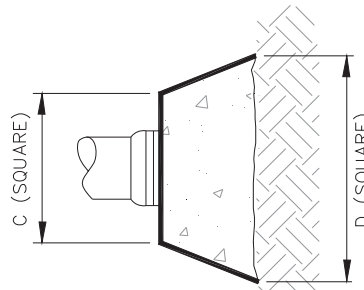
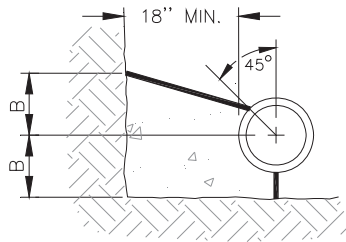
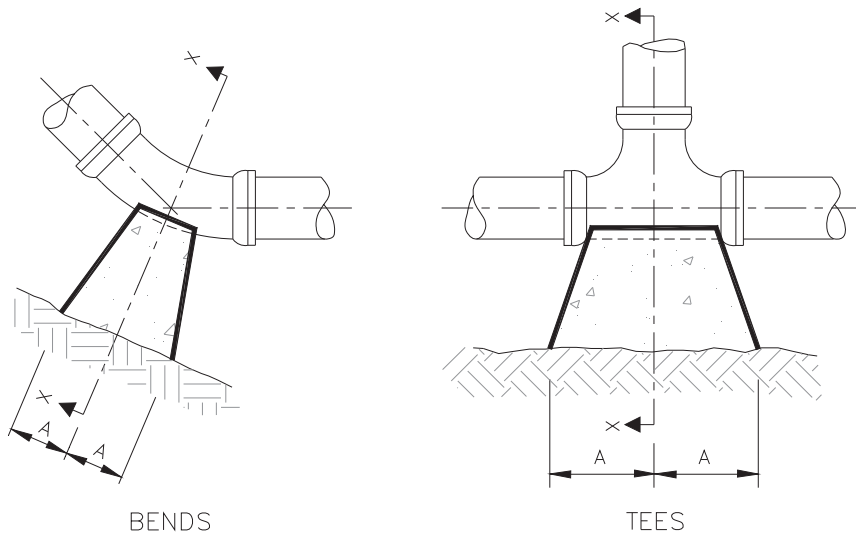

SECTION "X-X"
BENDS & TEES

PLAN & ELEVATION
PLUGS

GENERAL NOTES:

1. THRUST BLOCK BEARING AREAS SHALL BE POURED AGAINST UNDISTURBED MATERIAL.
2. JOINTS SHALL NOT BE COVERED BY THRUST BLOCKS. FITTINGS SHALL BE PROVIDED BY VISQUEEN OR PLASTIC POLY SHEETING.
3. ALTERNATE DESIGNED RESTRAINING SYSTEMS SHALL BE PROVIDED WHERE THRUST BLOCKS ARE NOT SUITABLE.

SIZE	1/4 BENDS		1/8 BENDS		1/16 BENDS		TEES		PLUGS	
	A	B	A	B	A	B	A	B	C	D
4"	8"	8"	12"	8"	3"	8"	8"	8"	10"	10"
6"	12"	12"	16"	10"	5"	9"	9"	12"	12"	20"
8"	16"	16"	22"	13"			13"	16"	12"	29"
10"	20"	20"	26"	17"			16"	20"	14"	36"
12"	24"	24"	29"	21"			18"	24"	16"	41"

City of Fort Walton Beach Engineering Standards	STANDARD THRUST BLOCK	SCALE: NTS	10-3-2012 KJN	DRAWING # ESM-9.10
--	-----------------------	---------------	------------------	-----------------------

Plotted Tuesday, October 18, 2005 11:03:12 AM - C:\Users\KNITZM-1\FWB\AppData\Local\Temp\A5C73D05CB2.DWG

Attachment: Engineering Standards Manual Draft (2016 : Approval of the Engineering Standards Manual)

GATE VALVE - 12" & SMALLER

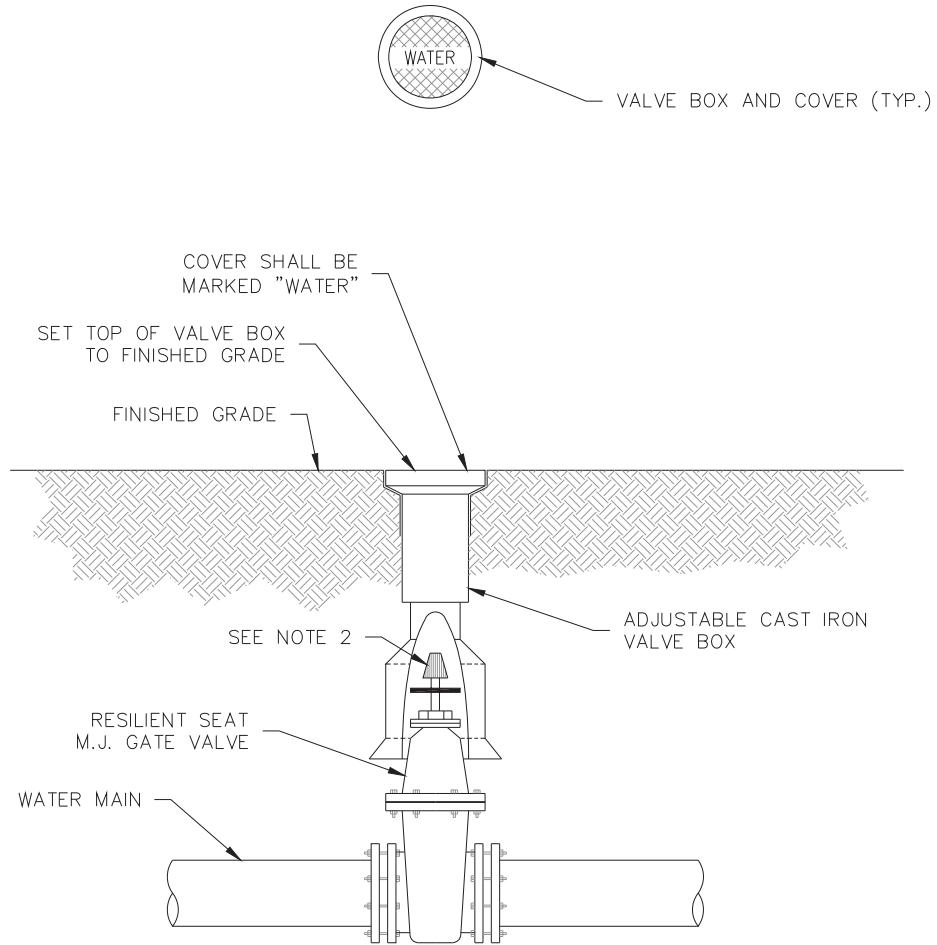

GENERAL NOTES:

1. GAVE VALVE SHALL BE OF THE RESILIENT SEAT TYPE.
2. PVC EXTENSIONS SHALL NOT BE USED ON VALVE BOX INSTALLATION.
3. THE ACTUATING NUT FOR DEEPER VALVES SHALL BE EXTENDED TO COME UP TO 4 FOOT DEPTH BELOW FINISHED GRADE.

City of Fort Walton Beach Engineering Standards	GATE VALVE - 12" & SMALLER	SCALE: NTS	10-3-2012 KJN	DRAWING # ESM-9.11
--	----------------------------	---------------	------------------	-----------------------

Plotted Tuesday, October 18, 2005 11:03:12 AM - C:\Users\KNITZM-1\FWB\AppData\Local\Temp\ASC2E693DE9.DWG

Attachment: Engineering Standards Manual Draft (2016 : Approval of the Engineering Standards Manual)

STANDARD FIRE HYDRANT

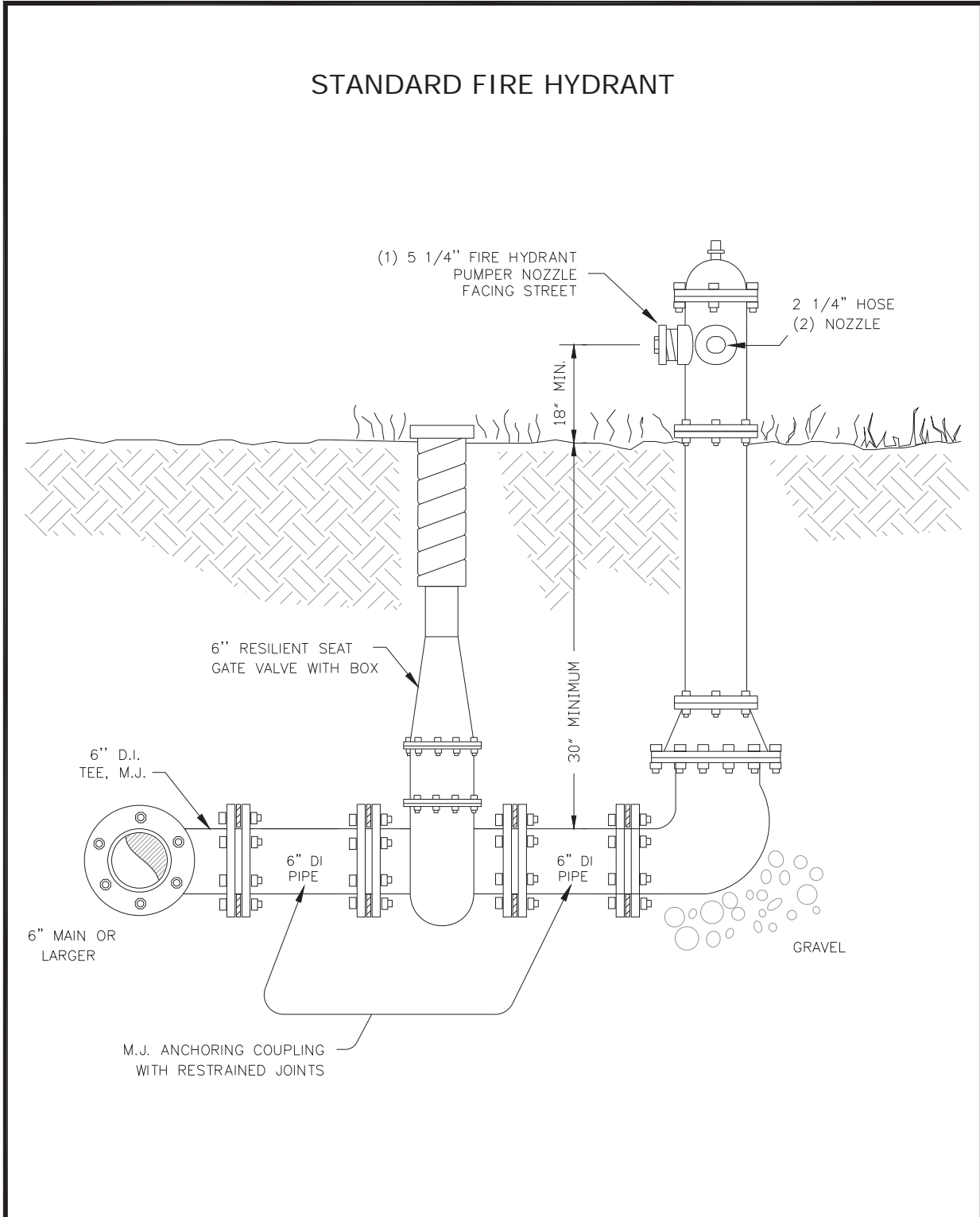

City of Fort Walton Beach Engineering Standards	STANDARD FIRE HYDRANT	SCALE: NTS	10-3-2012 KJN	DRAWING # ESM-9.12
--	-----------------------	---------------	------------------	-----------------------

Plotted Tuesday, October 18, 2005 11:03:12 AM - C:\Users\KNITZM-1\FWB\AppData\Local\Temp\A5C0E5B6AA6.DWG

Attachment: Engineering Standards Manual Draft (2016 : Approval of the Engineering Standards Manual)

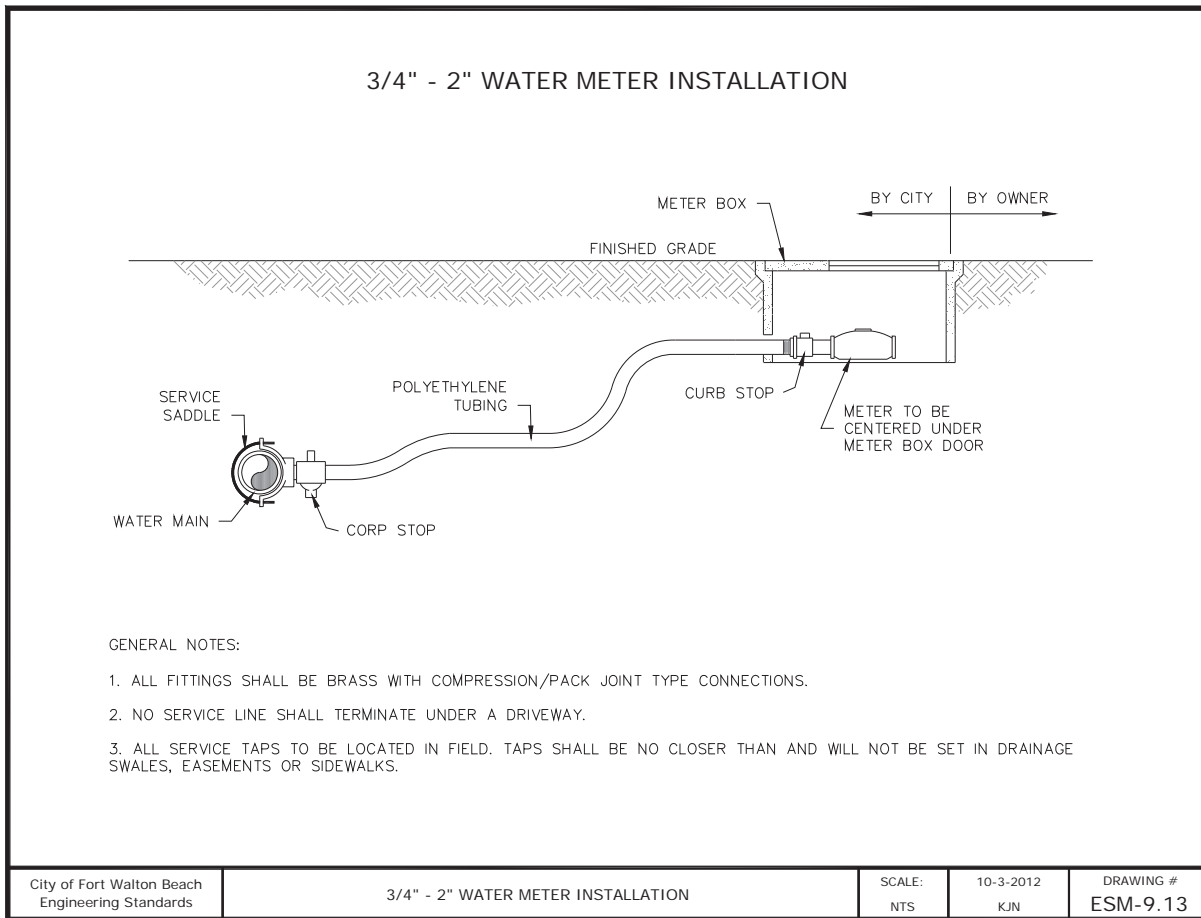

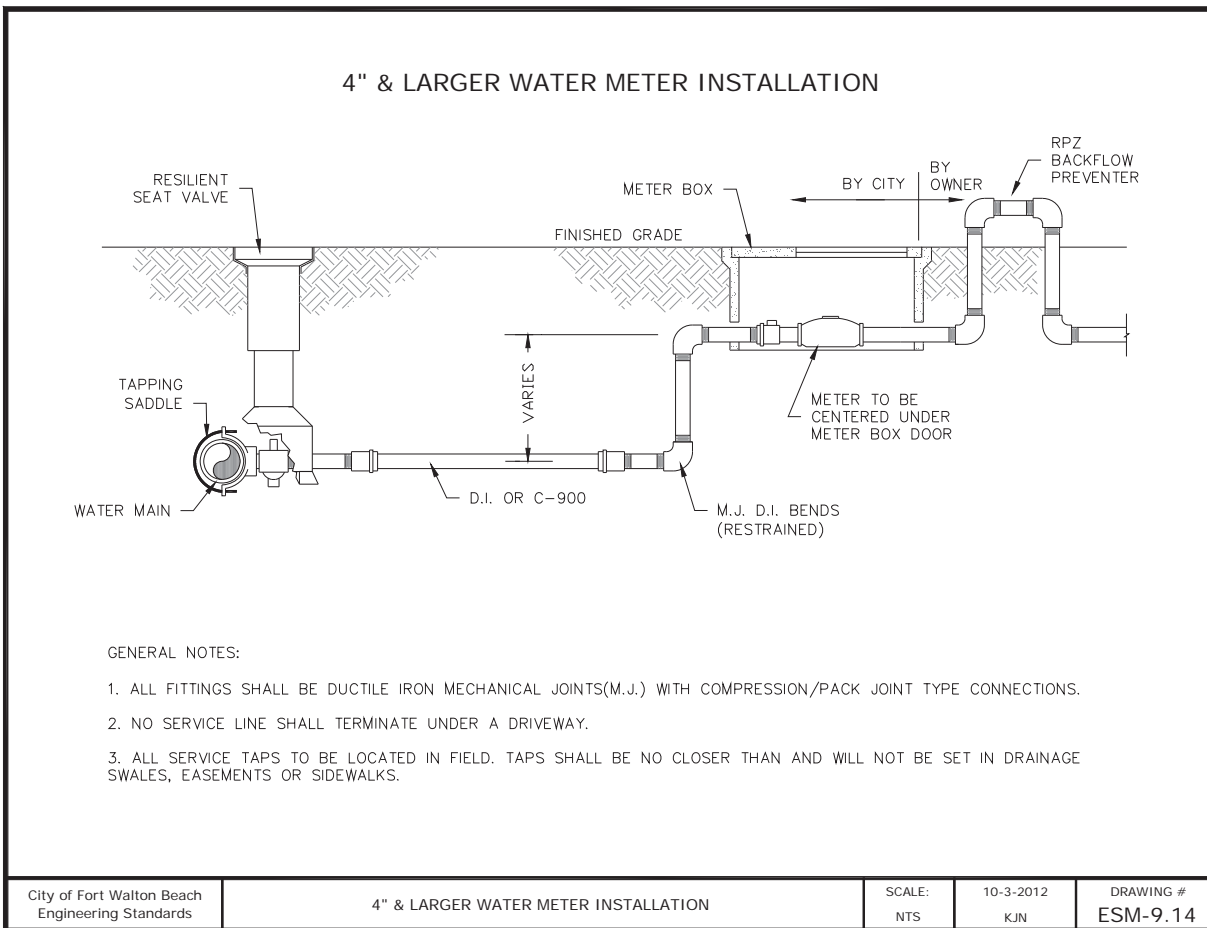

SANITARY SEWER SERVICE LATERAL

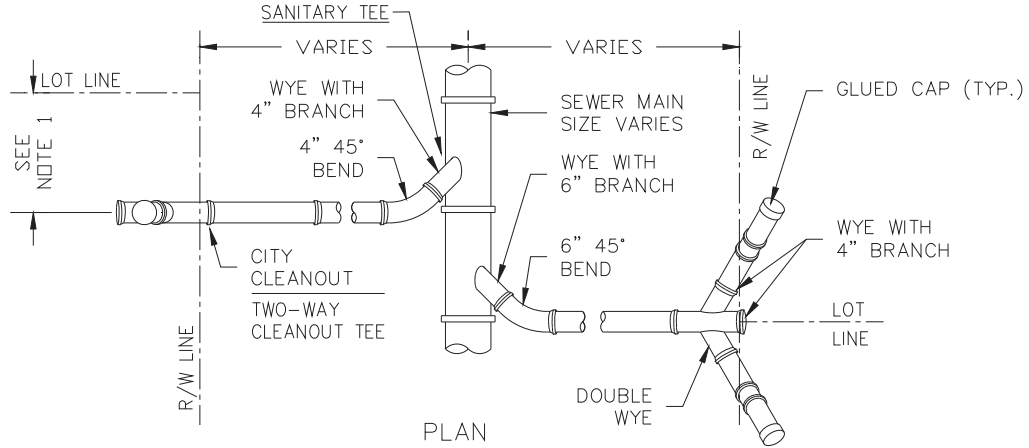

PLAN

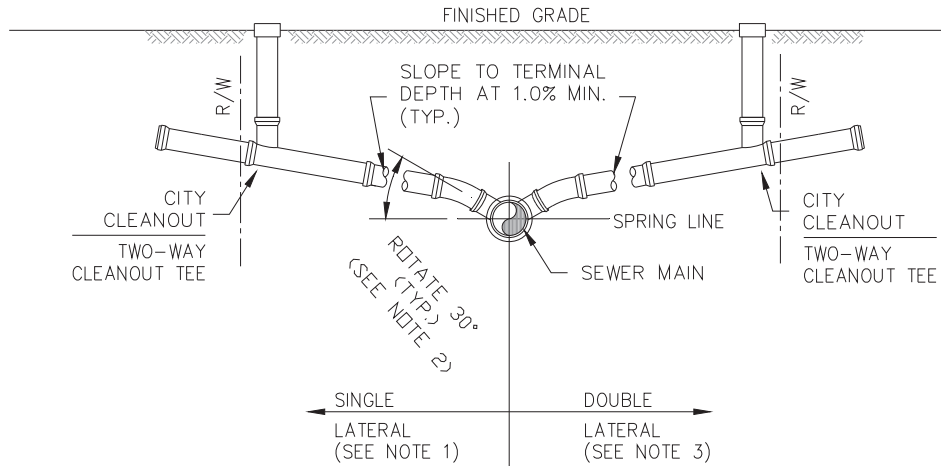

PROFILE

GENERAL NOTES:

1. LOCATE SINGLE LATERAL AS NEAR TO CENTER OF LOT AS POSSIBLE.
2. INVERT OF SERVICE LATERAL SHALL NOT ENTER SEWER MAIN BELOW SPRING LINE.
3. DOUBLE SERVICE LATERALS ONLY PERMITTED ON TAPS TO EXISTING GRAVITY MAINS WHERE EXISTING ROAD PAVEMENT MUST BE CUT.

City of Fort Walton Beach
Engineering Standards

SANITARY SEWER SERVICE LATERAL

SCALE:
NTS

10-10-2012
KJN

DRAWING #
ESM-9.15

Plotted Tuesday, October 18, 2005 11:03:12 AM - C:\Users\KNITZM-1\FWB\AppData\Local\Temp\A\$C59420626.DWG

Attachment: Engineering Standards Manual Draft (2016 : Approval of the Engineering Standards Manual)

STANDARD SEWER CLEANOUT (SIZE SAME AS MAIN)

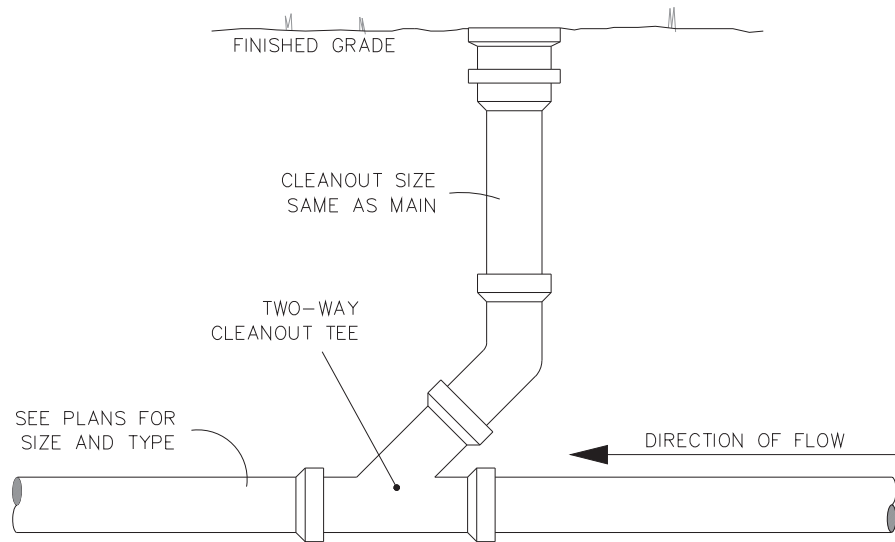

City of Fort Walton Beach
Engineering Standards

STANDARD SEWER CLEANOUT

SCALE:
NTS

10-10-2012
KJN

DRAWING #
ESM-9.16

Plotted Tuesday, October 18, 2005 11:03:12 AM - C:\Users\KNITZM-1\FWB\AppData\Local\Temp\ASC6FBE4184.DWG

Attachment: Engineering Standards Manual Draft (2016 : Approval of the Engineering Standards Manual)

STANDARD SEWER MANHOLE

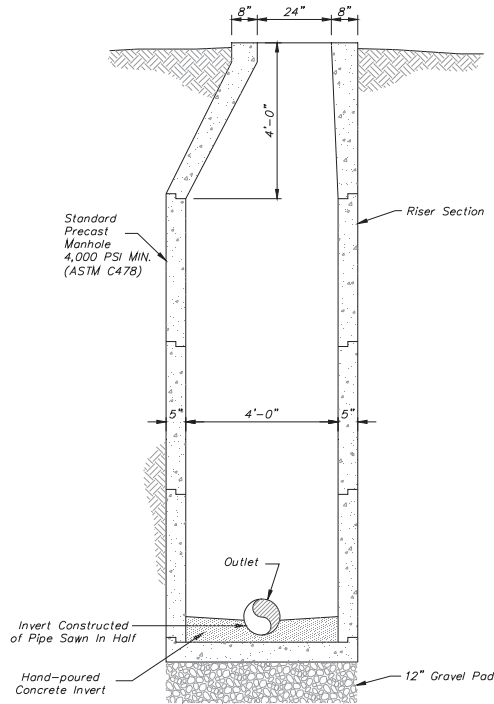

STANDARD SEWER MANHOLE
NOT TO SCALE

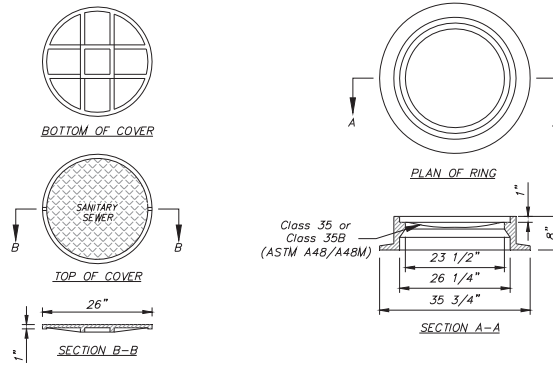

MANHOLE COVER & RING
NOT TO SCALE

City of Fort Walton Beach
Engineering Standards

STANDARD SEWER MANHOLE

SCALE:
NTS

10-10-2012
KJN

DRAWING #
ESM-9.17

Plotted Tuesday, October 18, 2005 11:03:12 AM - C:\Users\KNITZM-1\FWB\AppData\Local\Temp\ASC31083A19.DWG

Attachment: Engineering Standards Manual Draft (2016 : Approval of the Engineering Standards Manual)

STANDARD SEWER MANHOLE WITH DROP CONNECTION

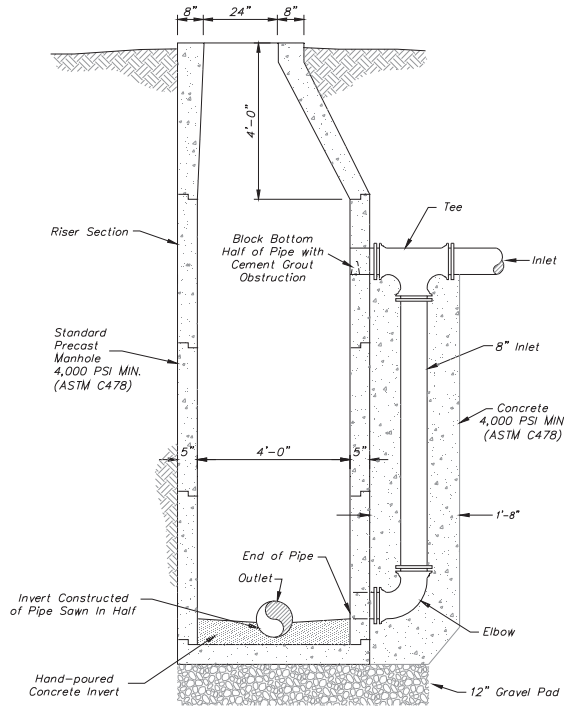

STANDARD SEWER MANHOLE WITH DROP CONNECTION
NOT TO SCALE

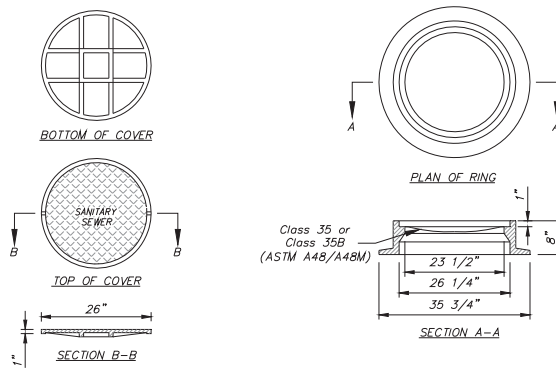

MANHOLE COVER & RING
NOT TO SCALE

City of Fort Walton Beach Engineering Standards	STANDARD SEWER MANHOLE WITH DROP CONNECTION	SCALE: NTS	10-10-2012 KJN	DRAWING # ESM-9.18
--	--	---------------	-------------------	-----------------------

Plotted Tuesday, October 18, 2005 11:03:12 AM - C:\Users\KNITZM-1\FWB\AppData\Local\Temp\ASC36A14484.DWG

Attachment: Engineering Standards Manual Draft (2016 : Approval of the Engineering Standards Manual)

APPENDIX 9A

“RESERVED”