

Another quality product from

EURO-PRO ™

INSTRUCTION MANUAL

English

Spanish

French

Model 377/374/373/372/372H

IMPORTANT SAFETY INSTRUCTIONS

When using an electrical sewing machine, basic safety precautions should always be followed, including the following.

Read all instructions before using this sewing machine.

This sewing machine is designed for household use.

DANGER-TO REDUCE RISK OF ELECTRIC SHOCK:

A sewing machine should never be left unattended when plugged in. Always unplug this sewing machine from the electrical outlet immediately after using and before cleaning.

Warning -To reduce the risk of burns, fire, electric shock or injury to persons...

1. Do not allow to be used as a toy. Attention is necessary when this sewing machine is used by or near children.
2. Use this sewing machine only for its intended use as described in this manual. Use only attachments recommended by the manufacturer as contained in this manual.
3. Never operate this sewing machine if it has a damaged cord or plug, if it is not working properly, if it has been dropped or damaged, or dropped into water. Return the sewing machine to the nearest authorized dealer or service center for examination, repair, electrical or mechanical adjustment.
4. Never operate the sewing machine with any air openings blocked. Keep ventilation openings from the sewing machine and foot control free from the accumulation of lint, dust, and loose cloth.
5. Never drop or insert any object into any opening.
6. Do not use outdoors.
7. Do not operate where aerosol spray products are being used or where oxygen is being administered.
8. To disconnect, turn all controls to the off O position, then remove plug from outlet.
9. Do not unplug by pulling on cord. To unplug, grasp the plug, not the cord.
10. Keep fingers away from all moving parts. Special care is required around the sewing machine needle.
11. Always use the proper needle plate. The wrong plate can cause the needle to break.
12. Do not use bent needles.
13. Do not pull or push fabric while stitching. It may deflect the needle, causing it to break.
14. Switch the sewing machine off O when making any adjustments in the needle area, such as threading needle, changing needle, threading bobbin, or changing presser foot and the like.
15. Always unplug sewing machine from the electrical outlet when removing covers, lubricating, or when making any other user servicing adjustments mentioned in the instruction manual.
16. Always unplug before replacing lamp. Replace bulb with the same rated 15 watts.

SAVE THESE INSTRUCTIONS

Contents

Principal parts	3-4
How to connect the machine to the power supply	4
How to use the foot control	4
How to replace the sewing lamp	4
Changing the needle	5
Thread and needle chart	5
To select a suitable needle	5
Removing and attaching the presser foot	6
Regulating the thread tension	6
Reverse stitch	7
The pattern selector	7-8
Removing the bobbin case and bobbin	8
Winding the bobbin	9
Threading the bobbin case	9
Threading the needle	10
Drawing up the bobbin thread	11
Straight stitch and zigzag stitch	11
Changing sewing direction	12
Fastening seams	12
Triple stretch stitch	12
Tricot zigzag stitch	13
Smocking stitch	13
Overlock stitch	13
Double action stitch	14
Double overlock stitch	15
Sewing buttonholes	14-15
Sewing zippers	15
Hemming	16
Sewing blind hems	16
Sewing embroidery	17
Darning plate	17
Buttons	17
Cleaning the feed dog	18
Cleaning the shuttle race	18
Free arm sewing	19
Trouble shooting: causes and remedies	20

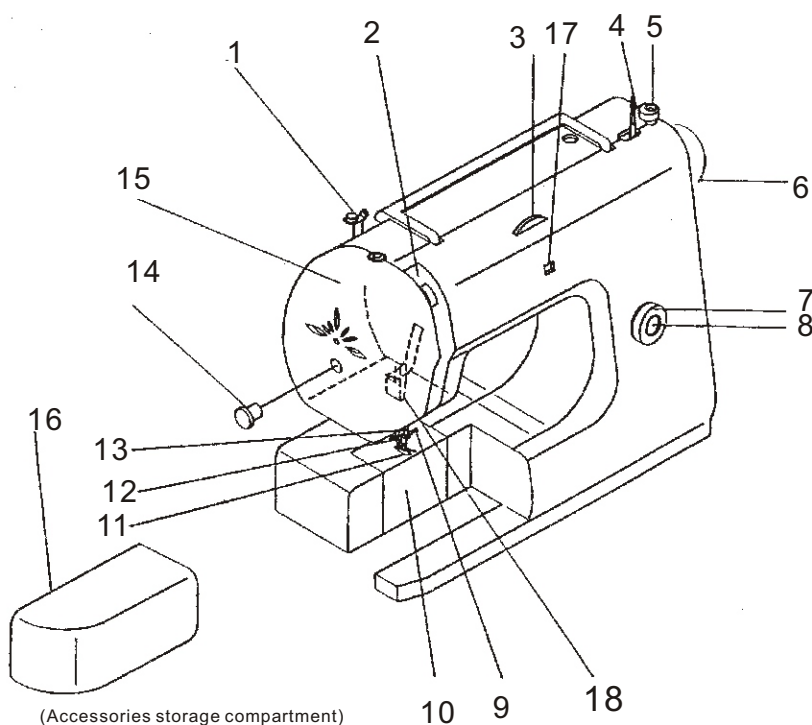

PRINCIPAL PARTS (Model 377)

- 1. Bobbin winder thread guide
- 2. Thread tension dial
- 3. Pattern selector dial
- 4. Bobbin winder spindle
- 5. Bobbin winder stopper
- 6. Balance wheel
- 7. Stitch length dial
- 8. Reverse button
- 9. Needle clamp and screw
- 10. Shuttle cover
- 11. Presser foot
- 12. Presser foot thumb screw
- 13. Needle
- 14. Screw for face plate
- 15. Face plate
- 16. Extension table
- 17. Stitch display
- 18. Presser foot lifter

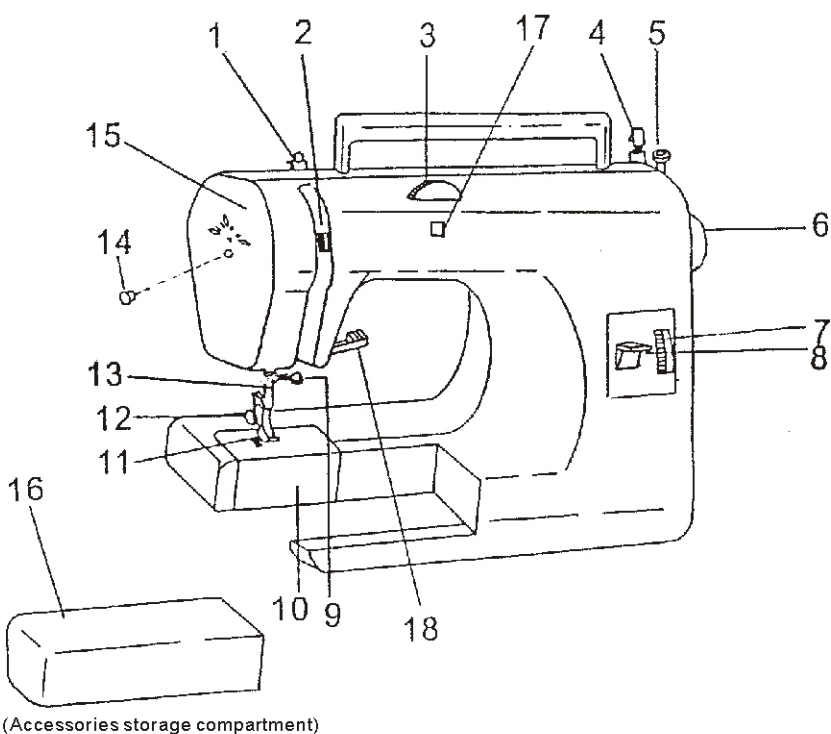

PRINCIPAL PARTS (Model 374)

- 1. Bobbin winder thread guide
- 2. Thread tension dial
- 3. Pattern selector dial
- 4. Bobbin winder spindle
- 5. Bobbin winder stopper
- 6. Balance wheel
- 7. Stitch length dial
- 8. Reverse button
- 9. Needle clamp and screw
- 10. Shuttle cover
- 11. Presser foot
- 12. Presser foot thumb screw
- 13. Needle
- 14. Screw for face plate
- 15. Face plate
- 16. Extension table
- 17. Stitch display
- 18. Presser foot lifter

PRINCIPAL PARTS (Model 373/372/372H)

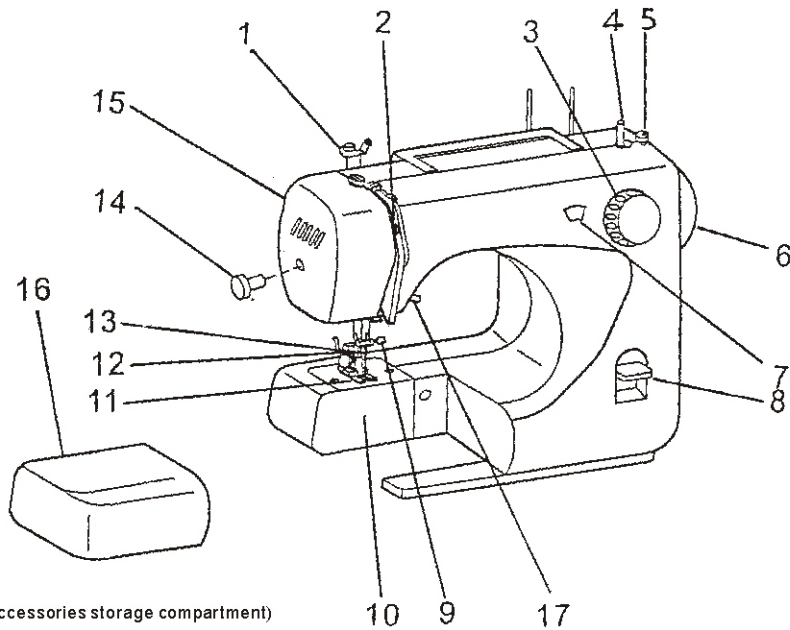

- 1. Bobbin winder thread guide
- 2. Thread tension dial
- 3. Pattern selector dial
- 4. Bobbin winder spindle
- 5. Bobbin winder stopper
- 6. Balance wheel
- 7. Stitch display
- 8. Reverse button
- 9. Needle clamp and screw
- 10. Shuttle cover
- 11. Presser foot
- 12. Presser foot thumb screw
- 13. Needle
- 14. Screw for face plate
- 15. Face plate
- 16. Extension table
- 17. Presser foot lifter

HOW TO CONNECT THE MACHINE TO THE POWER SUPPLY

1. Fit the machine plug into the machine.
2. Plug the power cord to the power supply.

Note: *Before plugging in the machine, ensure the voltage and number of cycles indicated, conforms to your electrical power supply.

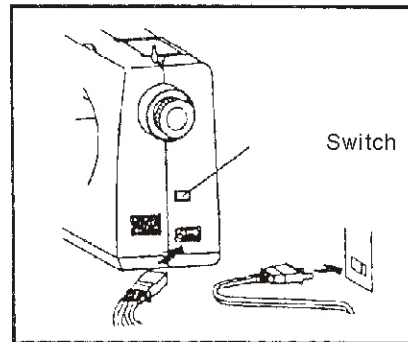

HOW TO USE THE FOOT CONTROL

Sewing speed can be varied by the foot control. The harder you press on the controller, the faster the machine runs.

Note: *By releasing the controller, the machine stops running automatically.

*Before using the machine, practice controlling the speed without threading.



HOW TO REPLACE THE SEWING LAMP

The sewing lamp is located behind the face plate. Remove the face plate by loosening the screw of the face plate.

Bulb type: ● To remove...Unscrew

● To replace...Screw

Note: *Before replacing a bulb, disconnect the machine from the power supply.

*Bulbs are available from sewing machine retailers. (Use a 15-Watt bulb)

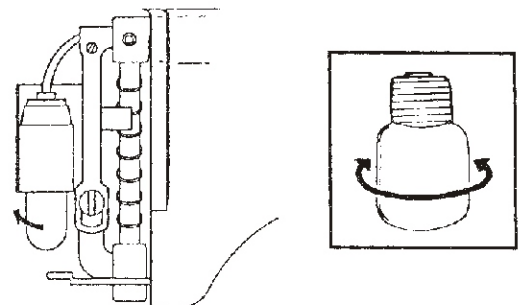

Caution!
Before leaving the machine, changing parts or doing any other work on it, always disconnect the plug from the wall socket.

THREAD AND NEEDLE CHART

	FABRICS	THREADS	NEEDLE SIZE
LIGHT WEIGHT	Sheer cottons, Silk, Synthetics, Georgette	Fine Silk Fine Cotton Fine Synthetic Fine Cotton Covered Polyester	9 or 11
MEDIUM WEIGHT	Medium Weight Cottons, Synthetics, Poplin, Velvet, Light Weight Woollens	50 silk 50 to 80 Cotton 50 to 60 Synthetic Cotton Covered Polyester	11 or 14
HEAVY WEIGHT	Heavy Weight Cottons, Denim Tweed, Gaberdine, Drapery	50 Silk 40 to 50 Cotton 40 to 50 Synthetic Cotton Covered Polyester	14 or 16

Note: *In general, fine threads and needles are used for sewing thin fabrics, and thicker threads and needles are used for sewing heavy fabrics. Always test thread and needle size on a small piece of fabric which will be used for actual sewing.

*Use the same thread for needle and bobbin.

*When sewing stretch, very fine fabrics and synthetics, use a STRETCH needle. The STRETCH needle effectively prevents skipped stitches.

*When sewing very fine fabrics, sew over a piece of paper to prevent yarn distortion.

CHANGING THE NEEDLE

1. Turn the balance wheel towards you until the needle is in its highest position.
2. Loosen the needle clamp screw by turning its top edge towards you. Remove the needle from the clamp.
3. Place the new needle into the needle clamp with its flat side facing away from you. Push the needle up into needle clamp as far as possible.
4. Tighten the needle clamp screw firmly.

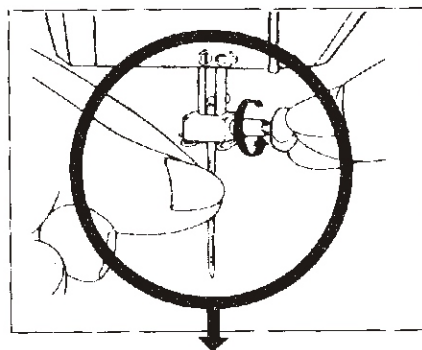

TO SELECT A SUITABLE NEEDLE

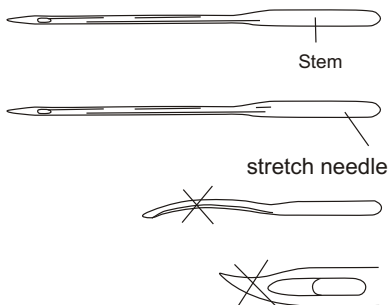

- A number indicating the size of needle is marked on the stem. The higher the number, the thicker the needle.
 - A STRETCH needle is recommended for stretch fabrics.
- * Do not use any needle which is bent or blunted.

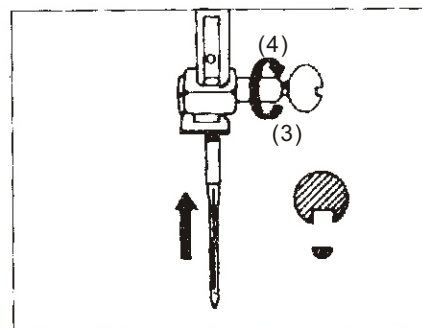

REMOVING AND ATTACHING THE PRESSER FOOT

To Remove:

1. Turn the balance wheel towards you until the needle is at its highest position.
2. By lifting the lever on the back of the foot holder, the presser foot will drop off.

Note: *Do not force the presser foot to remove it.

To Attach:

1. Place the presser foot so that the pin on the foot lies just under the groove of the foot holder. Lower the foot holder.
2. When the presser foot lifter is raised you'll find the presser foot is locked in place.

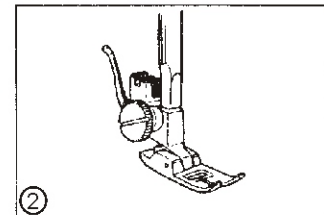
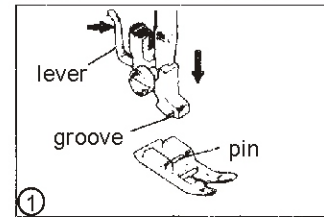
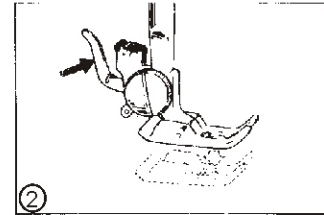
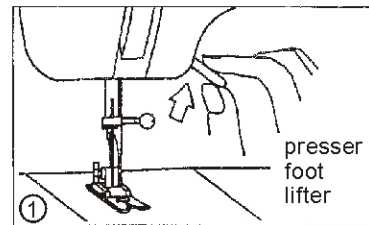

REGULATING THE THREAD TENSION

Generally, should any tension adjustment be necessary, the adjustment can normally be made by regulating the upper thread tension dial only. Bobbin thread tension has been adjusted at the factory and readjustment is seldom required except for special instances, thread and fabric.

Bobbin thread tension is just right when you can pull the thread from bobbin case easily with a little resistance. Thread tension may be adjusted by tightening or loosening the thread tension dial.

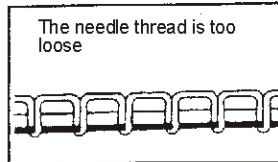
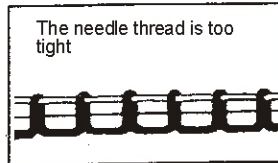
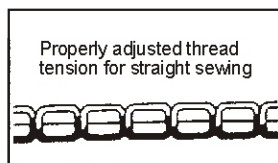

The needle thread and the bobbin thread should interlock in the center of two layers of fabric



The bobbin thread appears on the upper surface of the fabrics

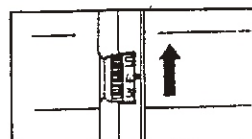

The needle thread appears on the underside of the fabrics

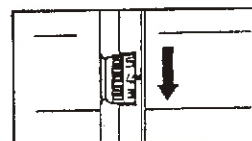

* How to adjust the bobbin thread tension

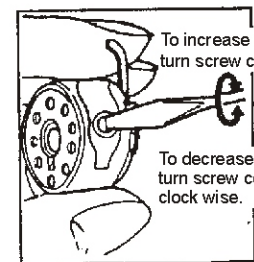

Remember the higher the number, the tighter the tension. Correctly balanced tensions for one fabric may not be suitable for another. The required tension depends upon the stiffness of fabric, thickness of the fabric, numbers of layers of fabric being sewn, as well as the type of stitch you are making. It is better to test the stitching on a scrap of the fabric you are using before starting to make a garment. The general range for many fabrics is 3-5.

STITCH LENGTH DIAL (Model 377 and 374 only)

To change the length of the stitches proceed as follows:

Turn the dial so that the number for the required stitch length is at setting mark. The numbers indicate the approximate stitch length in mm. The smaller the numbers, the shorter the stitch.

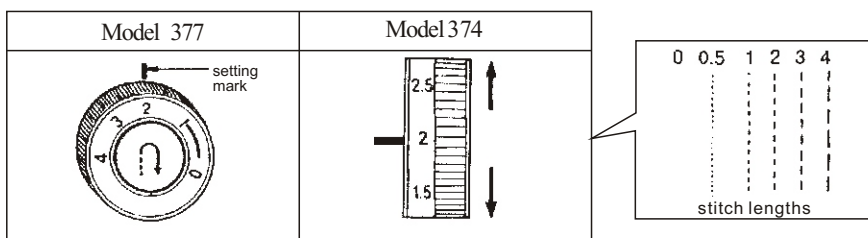





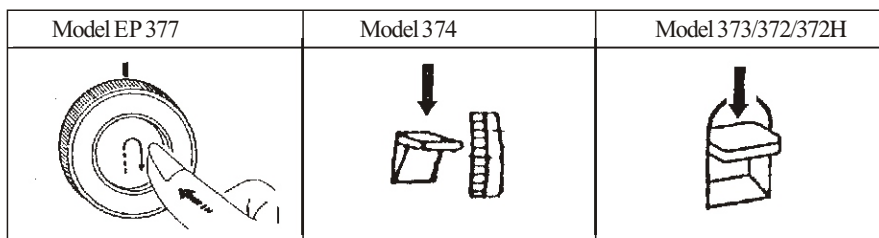





REVERSE STITCH: (Model EP 377/374/373/372/372H)

Press center of the stitch length dial (reversing button) and hold for reverse stitching. Fabric will immediately start feeding backwards. Release button and machine will resume normal forward sewing. Very useful for fastening ends of seams and darts without having to tie threads, and for strengthening seams.



THE PATTERN SELECTOR (Model 377)







The desired pattern can be selected by turning the pattern selector dial. The marks on the dial correspond to the patterns shown on the panel respectively, as follows;

- M() straight stitch, middle needle position
- O() straight stitch, left needle position
- 1-5(54321) zigzag stitch with variable width
- A() tricot stitch
- B() stretch blind stitch
- C() double action stitch
- D() reverse blind stitch
-  →  →  →  automatic buttonhole sewing

Selecting Stretch Stitch:

When sewing stretch stitch, set the stitch length dial at S.S.

When you release the engagement on the dial, the stretch stitch mechanism will be off automatically.

- M() triple straight stretch stitch, middle needle position.
- O() triple straight stretch stitch, left needle position.
- 1-5(54321) triple zigzag stretch stitch or ric-rac stitch
- A() smocking stitch
- B() fancy stretch stitch or blanket stitch
- C() double overlock stitch
- D() overlock stitch

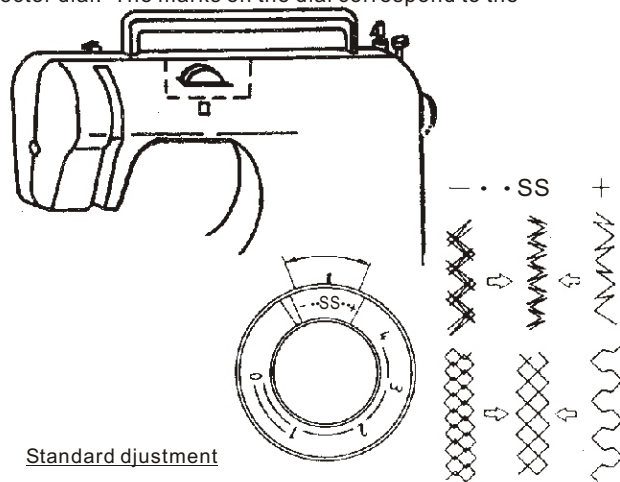

Standard adjustment

Turn the stitch length dial so that the SS mark is uppermost.

This is a standard adjustment for most types of fabric. For different types of fabric, adjustment may be necessary. To shorten the stretch stitches, turn the dial slightly towards - To lengthen, turn the dial towards +

On most fabrics, these adjustments allow for various pattern possibilities. When making stretch stitches, the mark  must always be within the SS range - (see drawing).







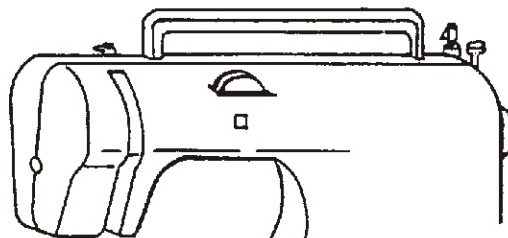

THE PATTERN SELECTOR (Model 374)

The desired pattern can be selected by turning the pattern selector dial. The marks in the stitch display correspond to the patterns shown on the panel respectively, as follows:

- A () straight stitch, middle needle position
 - B () straight stitch, left needle position
 - C () zigzag stitch with variable width
 - D () tricot stitch
 - E () stretch blind stitch
 - F () double action stitch
 - G () reverse blind stitch
-  →  →  →  automatic buttonhole sewing



THE PATTERN SELECTOR (Model 373/372/372H)

- 1 - 3 () straight stitch
 - 4 - 6 () zigzag stitch
 - 7 () triple zigzag stretch stitch
 - 8 () triple straight stretch stitch
 - 9 () overlock stitch
 - 10 () smocking stitch
 - 11 () tricot stitch
 - 12 () shell stitch
- () automatic buttonhole sewing

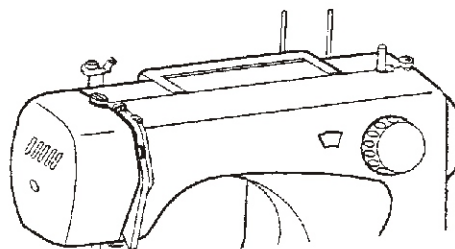

RE MOVING THE BOBBIN CASE AND BOBBIN

1. Raise the presser foot and turn the balance wheel towards you until the thread taked-up lever is at its highest position.

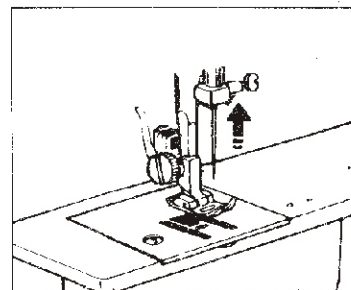

2. Open the shuttle cover.

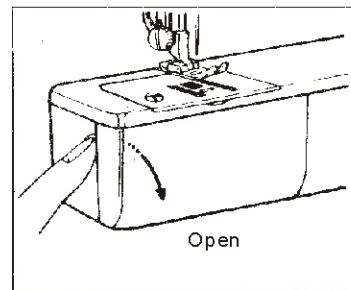

3. Open hinged latch of bobbin case and pull bobbin case out of machine.

Release the latch and the bobbin will fall out. As long as you hold the bobbin case latch open, the bobbin cannot drop out.

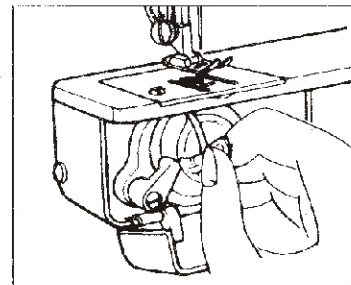

WINDING THE BOBBIN

1. Draw thread from spool through bobbin winder tension disc as shown.
2. Pull end of thread through hole in bobbin as shown.
3. Push bobbin winder shaft to far left position, if it is not already there. Place bobbin onto shaft with end of thread coming from top of bobbin. Push bobbin winder shaft to right until it clicks. Hold onto end of thread.
4. Start machine. The thread that is held will snap or may be trimmed with a scissors, Bobbin will cease turning when completely filled. Push shaft to left to remove bobbin.

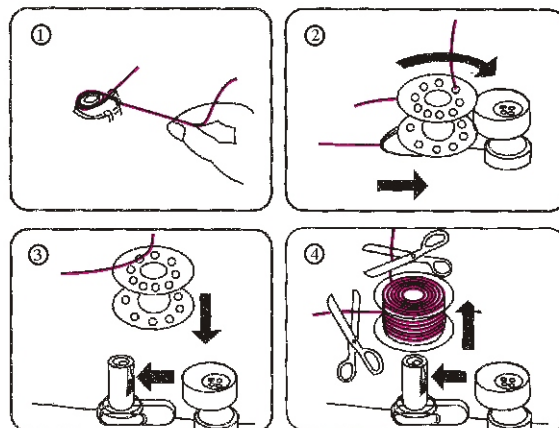
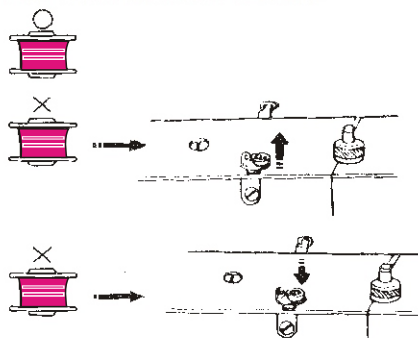
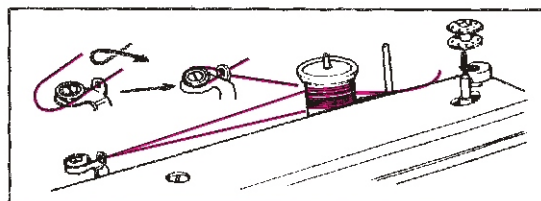
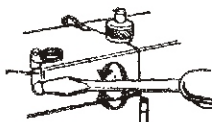

When the bobbin winding is incorrect, release the screw of the upper thread guide and adjust the thread guide up or down until the winding of the bobbin is balanced.

THREADING THE BOBBIN CASE

Hold the bobbin between the thumb and forefinger of your right hand and pull off about 15cm (6 inches) of thread.

1. Hold the bobbin case in your left hand as shown and place the filled bobbin inside.
2. Pull the thread into the slot in the edge of the bobbin case.
3. Now pull the thread under the tension spring and into the thread eyelet.

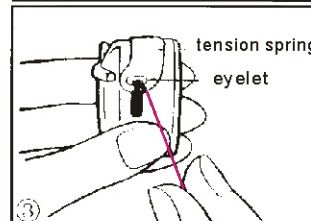
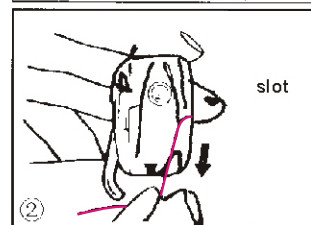
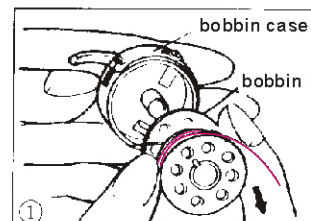

To insert the bobbin case and bobbin.....

Ensure that about 15 cm (6 inches) of thread extends out of bobbin. Hold the bobbin case so that long finger on case points up. Open the latch of bobbin case. Slip the bobbin case over the center pin of hook and press in place until the long finger of the bobbin case enters the notch entirely to lock the bobbin in place. Release latch and press it down.

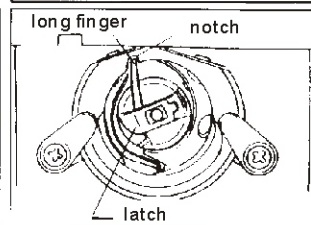
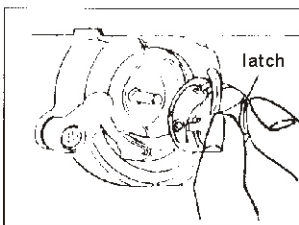

THREADING THE NEEDLE

Install the spool pin behind the machine (as shown in fig A).

Place spool on spool pin, with thread coming from the back of the spool. Place the take-up lever 5 in the highest position.

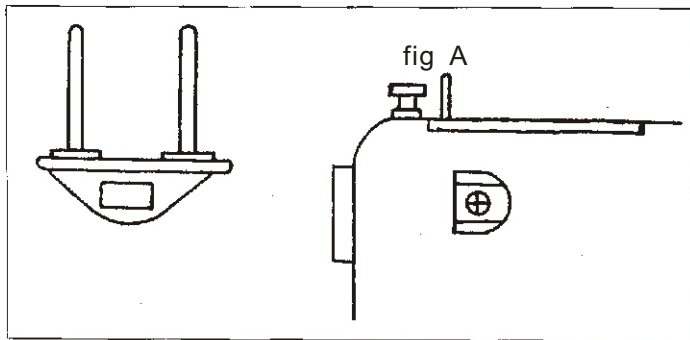
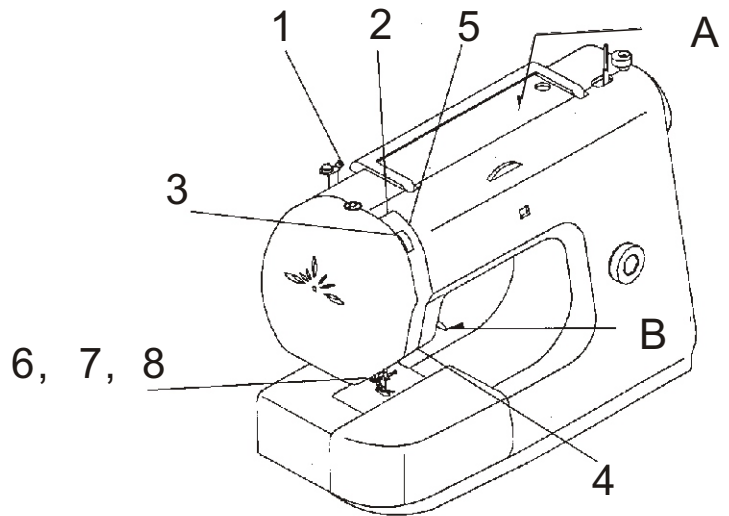

1. Raise the presser foot using the foot lever marked B.
2. Draw the thread through the thread guides on the top cover as shown in Fig. 1 & 2.
3. Hold the spool still with right hand, pull the end of the thread between the tension disk as shown in Fig. 3.
4. Following the slotted threading path, pull the thread down to the thread check spring (inside) and lead it across from left to right.
5. Pull the thread upward and slip into the slotted hole of thread take-up level from left to right ⑤ .
6. Draw the thread through guides ⑥ and ⑦, and thread the needle from front to rear⑧, leave the thread about 15cm(6 inches) long underneath the presser foot.

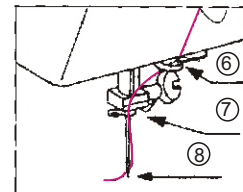
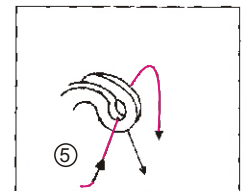
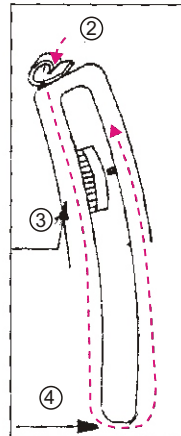
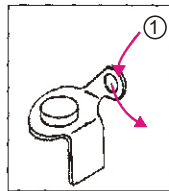
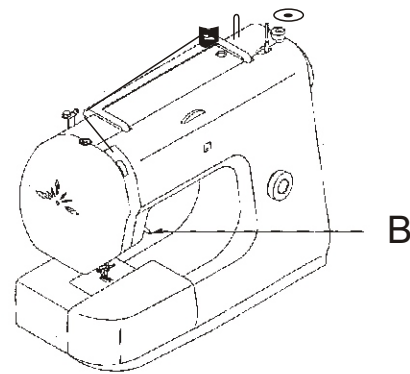

DRAWING UP THE BOBBIN THREAD

1. Hold the end of the needle thread with your left hand.

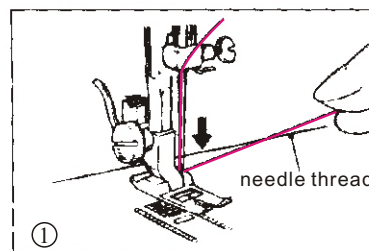

2. Turn the balance wheel slowly towards you with your right hand until the needle goes down and comes up. Then stop the balance wheel when the take-up lever is at its highest position.



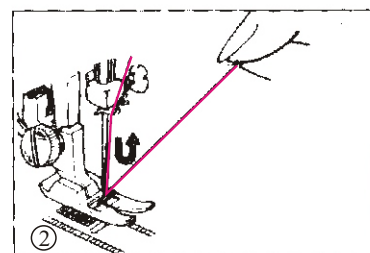

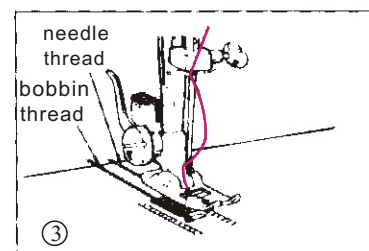

Lightly draw up the needle thread forming a loop with the bobbin thread.



3. Pull about 15cm (6 inches) of both threads away from you under the presser foot.



STRAIGHT STITCH AND ZIGZAG STITCH

	Model 377	Model 374	Model 373/372/372H
Presser foot	zigzag foot	zigzag foot	
Pattern selector	M () or O () (for straight stitch) 1 - 5 (54321) (for zigzag stitch)	A () or B () (for straight stitch) C () (for zigzag stitch)	() (for straight stitch) () (for zigzag stitch)
Stitch length dial	0.3-4	0.3-4	-

Starting Sewing

1. Be sure both the threads are drawn back under the presser foot.
2. While holding the threads with your left hand, turn the balance wheel toward you to bring the needle into the fabric where you wish to start sewing.
3. Lower the presser foot, and press the speed controller gently, then start sewing slowly.

*Sew a few reverse stitches by pushing reverse button for reinforcing the end of seams.

*Raise the needle to its highest position before turning the pattern selector dial and stitch width dial.

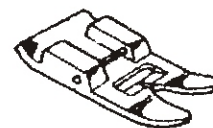

zigzag foot

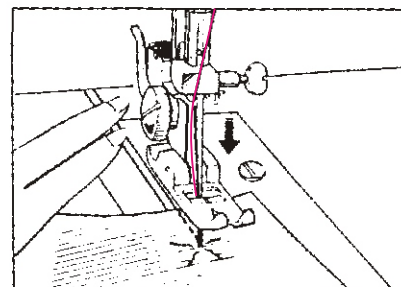

Changing Sewing Directions

1. Stop the machine, and turn the balance wheel toward you to bring the needle down into the fabric. Raise the presser foot.
2. Pivot the fabric around the needle to change direction as desired.
3. Lower the presser foot and continue sewing.

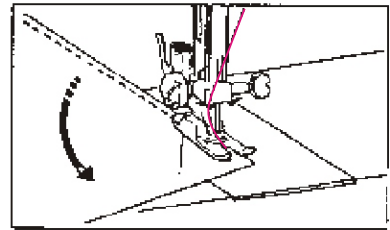

Fastening Seams

1. For fastening the ends of seams, press in the reversing button and sew several reverse stitches.
2. To remove the fabric, raise the presser foot and draw the fabric away from you.
3. Cut threads on thread cutter at the rear of presser bar or with a pair of scissors.
Leave about 15 cm (6 inches) of thread hanging from the needle eye.

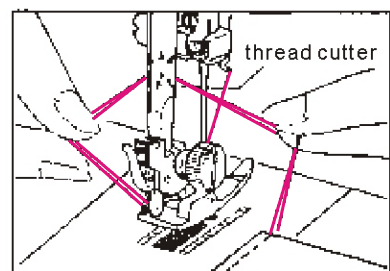





TRIPLE STRETCH STITCH (Model 374/373/372/372H)

If you wish to sew stretch fabrics, this is the right stitch to avoid thread breaking. This is also very suitable for seams that need great strength, e.g. crotch seams or pocket seams.

TRIPLE STRAIGHT STRETCH STITCH

TRIPLE ZIGZAG STRETCH STITCH

	Model 377	Model 374	Model 373/372/372H
Presser foot	zigzag foot	—	zigzag foot
Pattern selector	M ()	—	8 ()
Stitch length dial	S.S.	—	—



	Model 377	Model 374	Model 373/372/372H
Presser foot	zigzag foot	—	zigzag foot
Pattern selector	O ()	—	7 ()
Stitch length dial	S.S.	—	—

Note: * Use a STRETCH needle.

The blue tipped shank needle effectively prevents skipped stitches.

TRICOT ZIGZAG STITCH

This stitch is very suitable for darning tears. It can also be used for reinforcing stretch materials and sewing on fabric parts.

	Model 377	Model 374	Model 373/372/372H
Presser foot	zigzag foot	zigzag foot	zigzag foot
Pattern selector	A ()	D ()	11 ()
Stitch length dial	0.3 to 4	0.5 to 4	-

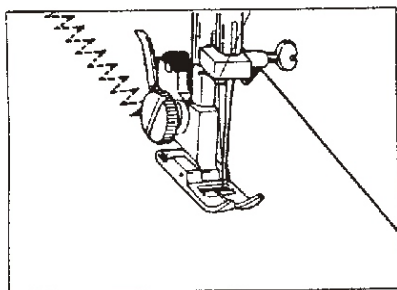

Note: *Use a STRETCH needle.
The stretch needle effectively prevents skipped stitches.



SMOCKING STITCH

With a narrow strip of fabric directly under the line of gathering, stitch over the gathers. The design will be a series of small diamonds.

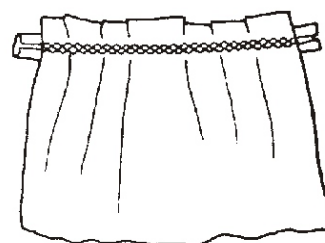

When smocking a garment, the stitching should be done before the piece is sewn into the garment.

	Model 377	Model 374	Model 373/372/372H
Presser foot	zigzag foot		zigzag foot
Pattern selector	A ()		10 ()
Stitch length dial	S.S.		-



OVERLOCK STITCH

With this seam it is possible to prevent raw edges, especially on easily fraying fabrics, with a good-locking and lasting edge finish.

	Model 377	Model 374	Model 373/372/372H
Presser foot	zigzag foot	—	zigzag foot
Pattern selector	D ()	—	9 ()
Stitch length dial	S.S.	—	—

Place the fabric under the presser foot so that the stitches are made over the edge.

Lower the presser foot and start sewing.

Guide the material lightly as shown.

Sew on a piece of waste fabric to check the machine setting.

The overlock stitches are formed correctly when the needle sews to the right and just misses the fabric edge.

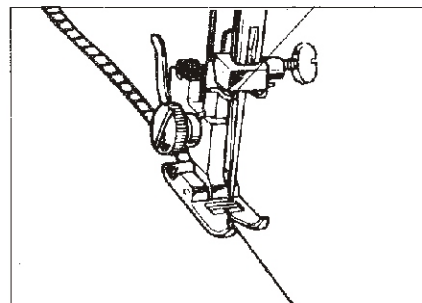

Note: *Use a STRETCH needle.

The stretch needle effectively prevents skipped stitches.



DOUBLE ACTION STITCH

This is a good stitch to use in attaching or binding elastic fabrics and stretch lace, lingerie stretch knit. The stitch is decorative as well as useful.

	Model 377	Model 374	Model 373/372/372H
Presser foot	zigzag foot	zigzag foot	—
Pattern selector	C ()	F ()	—
Stitch length dial	1 to 2.5	1 to 2.5	—

DOUBLE OVERLOCK STITCH (Model EP 377 only)

Use this versatile stitch to insert elastic in garments. Simply stitch elastic into place, making sure it is evenly spaced. To do this, mark the correct length piece into quarters, then match these markings with center front and side seams.

Presser foot	zigzag foot
Pattern selector	C ()
Stitch length dial	S.S.

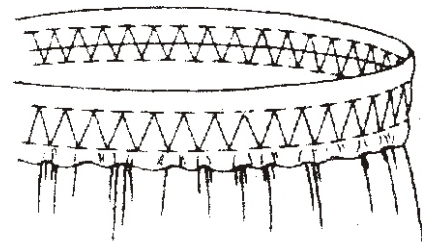
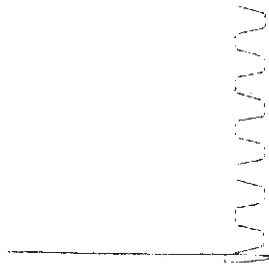
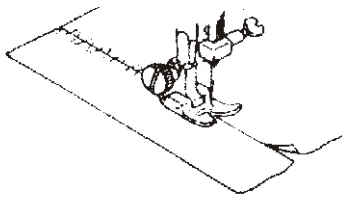

DECORATIVE EDGING

Turn the raw edge under 2cm and press. Place the fabric right side up with the middle of the turnover under the center of the presser foot, so that the stitch sews on to the fold and just over the raw edge underneath.



SEWING BUTTONHOLES

The built-in buttonhole mechanism of this machine makes it possible to sew button holes in a short time without turning the material.

	Model 377/374	Model 373/372/372H
Presser foot	buttonhole foot	buttonhole foot
Pattern selector		
Stitch length dial	0.5 to 1	—

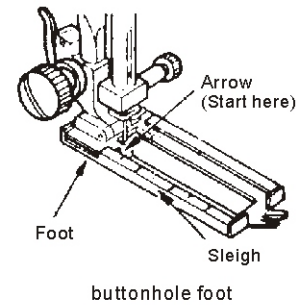

Raise the foot and the needle to its highest position. Replace the foot with the transparent buttonhole foot for sewing buttonholes. Mark the location and the desired length of buttonhole on the fabric using a pencil or tailor's chalk.

Note: (Model EP 377 and 374 only)



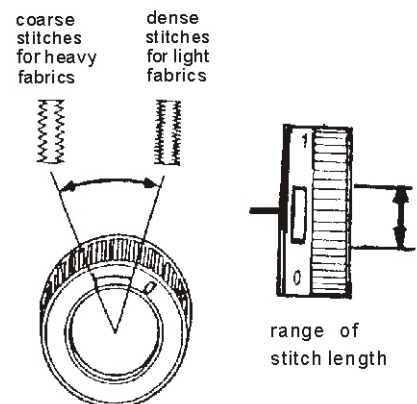

- *To find the most suitable stitch length, it is better to sew a sample buttonhole on a piece of waste fabric.
- *When sewing very fine fabrics and synthetics, decrease the pressure of foot and sew over a piece of paper to prevent yarn distortion.

*The mark on the stitch length dial shows a range of buttonhole sewing. An adjustment can be made by setting the mark, as shown.

*Buttonhole stitch length is adjustable only on one side.





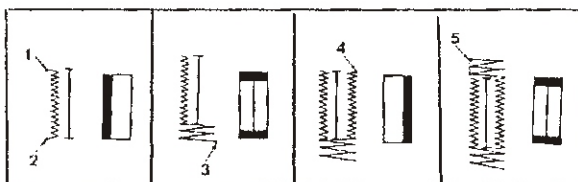

SEWING BUTTONHOLES (Model 377 and 374)

1. Set the pattern selector at . Then pass the needle thread through the opening in the buttonhole foot and draw both needle and bobbin threads to the left side. Turn the balance wheel towards you until the needle comes to the point (1).
2. Lower the foot and sew slowly until the desired length is sewn, then stop the machine at (2).
3. Raise the needle and set the selector at . Then sew several stitches of bar tack until the needle is at point (3).
4. Raise the needle and set the selector at  then sew the right side of buttonhole the same length as the left side of buttonhole. Stop the machine at (4).
5. Raise needle and set the selector at  then sew several stitches of final bar tack. Stop the machine with the needle at point (5). To lock threads, set the pattern selector at B \int (zero point of zigzag width). And sew a few stitches.
6. Cut the buttonhole open carefully using a seam ripper, taking care not to damage the bar tacks.

(Model EP 377 and 374 only)



SEWING BUTTONHOLES (Model 373/372/372H)

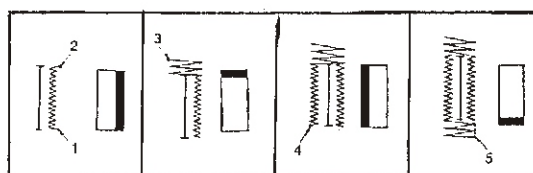

1. Set the pattern selector at . Then pass the needle thread through the opening in the buttonhole foot and draw both of needle and bobbin threads to the right side. Turn the balance wheel towards you until the needle comes to the point (1).
2. Lower the foot and sew slowly until a desired length is sewn, then stop the machine at (2).
3. Raise the needle and set the selector at  then sew several stitches of bar tack until the needle is at point (3).
4. Raise the needle and set the selector at  then sew the left side of buttonhole just as the same length as the right side of buttonhole. Stop the machine at (4).
5. Raise the needle and set the selector at  then sew several stitches of final bar tack. Stop the machine with the needle at point (5).
6. Cut the buttonhole open carefully using a seam ripper, taking care not to damage the bar tacks.

(Model 373/372/372H)



Note: To make a heavier buttonhole, sew twice by repeating the same procedure.

SEWING ZIPPERS

	Model 377	Model 374	Model 373/372/372H
Presser foot	zipper foot	zipper foot	zipper foot
Pattern selector	M ()	A ()	1-3 ()
Stitch length dial	1 to 4	1 to 4	—

Raise the foot and the needle to its highest position by turning the balance wheel towards you. Replace the foot with the zipper foot.

1. Pin or baste the zipper tape to the fabric and place the workpiece in position under the foot. Attach snap on zipper foot so that the needle passes on its left hand side.
*When starting sewing, both needle and bobbin threads ends should be put away under the foot.
2. Sew on the right side of the zipper by guiding Zipper teeth as close as possible to the needle drop. Before the foot reaches the slider on the zipper tape, raise the foot and open the zipper by keeping the needle in the fabric.
Lower the foot and sew on the remaining of the seam,
3. To sew the left side zipper change position of foot to bring the foot to the left side of the needle. Sew on in the same way as you did on the right side of zipper.

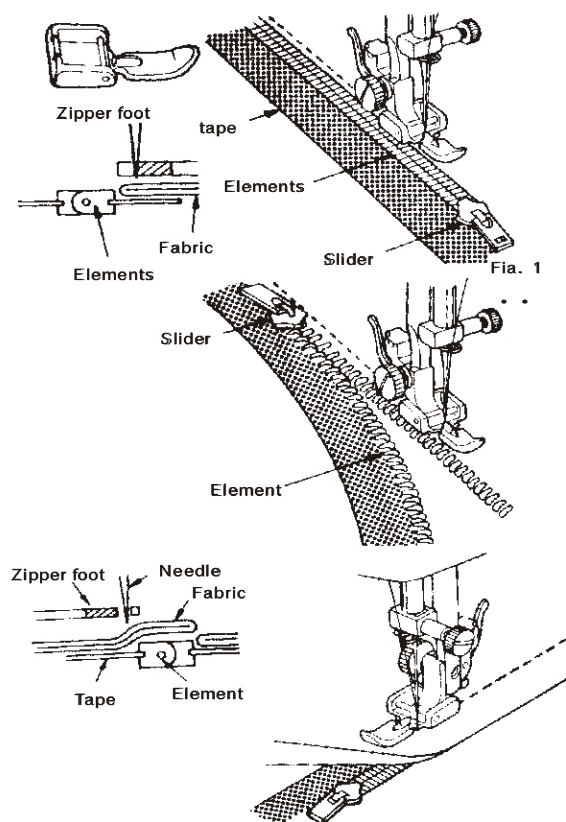

HEMMING (Model 377 only)

Presser foot	hemmer foot
Pattern selector	M ()
Stitch length dial	1 to 4

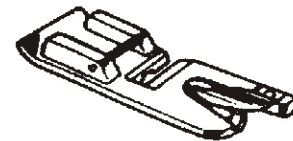

Raise the foot and the needle to its highest position. Replace the foot with the hemmer foot.
 Fold over the fabric edge by about 3mm (1/8 inches) and place it under the foot. Secure the folded edge with a few stitches. Take out the workpiece and draw the hem into the hemmer foot by pulling on the threads.
 Lower the foot and sew the hem.
 During sewing, fold the fabric to the left a little and allow it to run into the hemmer foot.
 Make sure that the fabric does not move under the right half of the foot. The fabric must be fed into the scroll of the hemmer sufficiently so that the workpiece edge runs freely through the groove under the foot.

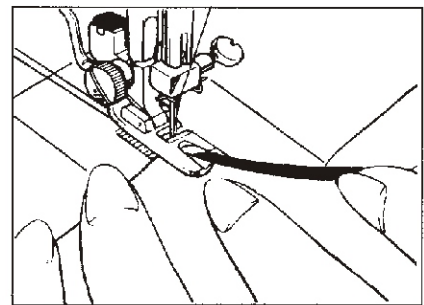
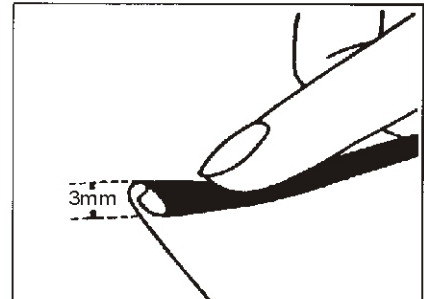

hemmer foot



SEWING BLIND HEMS (Model 377/374/373/372/372H)

	Model 377	Model 374	Model 373/372/372H
Presser foot	blind hem foot	blind hem foot	—
Pattern selector	B ()	E ()	—
Stitch length dial	1 to 3	1 to 3	—

1. Turn up the hem to the desired width and press. (Fig. 1)
2. Fold hem back against the right side of the garment with top edge of hem extending about 4 mm (1/6 inches) to the right side of the garment folded. (Fig. 2)
3. Place the garment under the foot so that double-folded edge runs along the hemlguide and lower the foot.
 Sew slowly for better control, making sure the narrow zigzag stitches are sewn on the hem edge and wide zigzag stitches will just catch one thread of folded edge. (Fig. 3)
4. Unfold the fabric and you will have a blind stitch hem (Fig. 4)

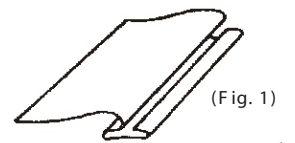

(Fig. 1)

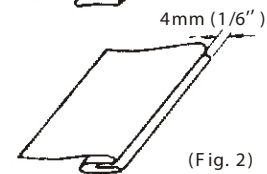

(Fig. 2)

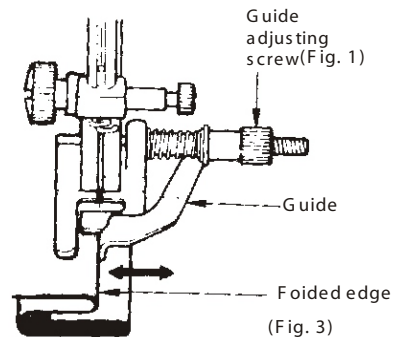

(Fig. 3)



(Fig. 4)

SEWING EMBROIDERY

Presser foot	darning plate
Pattern selector	() or zig zag

Raise and take off the foot.
Place the fabric in embroidery hoop. Place darning plate over needle plate (see below). Lower the presser foot lifter. Hold the embroidery hoop firmly with your hand.

While sewing the desired pattern, move the embroidery hoop slowly and do not allow your fingers to get near the needle.
*Set the needle thread tension a little looser so that the bobbin thread is not pulled through to the right side of fabric.
(See page 13).
*It is recommended to mark the required embroidery pattern on the right side of the fabric with a pencil or tailor's chalk.

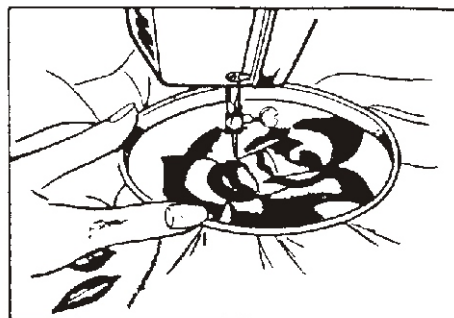
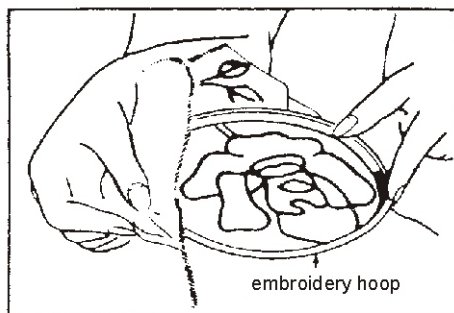

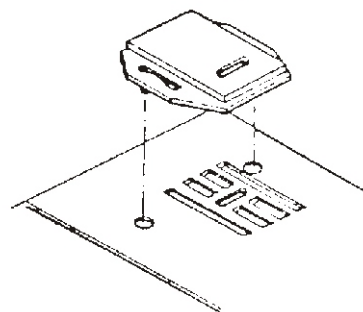

DARNING PLATE

There are a few times when you want to control the feeding of the fabric yourself. Raise needle to its highest position and raise presser foot. Place darning plate over needle plate aligning two pins of darning plate with holes of needle plate. You may then determine the movement of the fabric yourself. See above for embroidery.



BUTTONS

	Model 377	Model 374	Model 373/372
Presser foot	button foot	—	button foot
Pattern selector	1-5()	—	4-6()



Button foot

Thread Shank

Sew-through buttons on coats and jackets should have a thread shank to make them stand away from the fabric. Place a straight pin or sewing machine needle on top of button between the holes, and sew over the pin or needle. Pull thread to back of button and wind around stitches to form a firm shank. Tie thread ends securely.

1. Align two holes of button with slot of presser foot and lower foot to hold the button securely.
2. Turn hand wheel manually until needle point is just above button.
3. Adjust stitch selector so needle enters right hole of button.
4. Turn hand wheel by hand so needle enters second hole. The stitch selector may need to be adjusted again. Stitch a number of times.

NOTE:

- You may find it helpful to use transparent tape to position your button and to keep it in place during sewing. Tear away after stitching.
5. Finish sewing with an extra two inches of thread remaining. Draw these threads to reverse side of garment and tie.

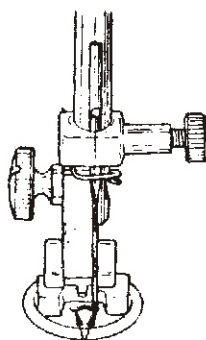

Holes of button

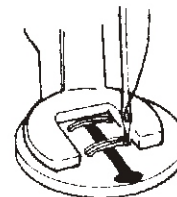

CLEANING THE FEED DOG

It is necessary to keep the feed dog teeth always cleaned in order to ensure smooth sewing.

1. Remove the needle and the presser foot.
2. Unscrew the needle plate set screws with a screw driver to take off the needle plate from the machine.
3. With a brush, clean out dust and lint clogged on the feed dog teeth.
4. Refit the needle plate.

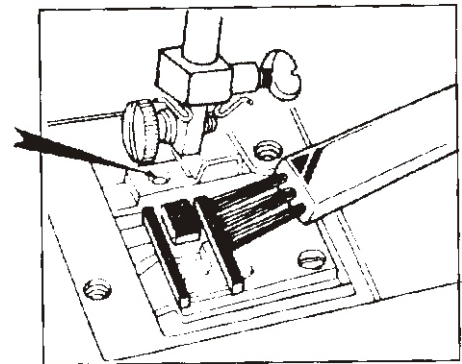
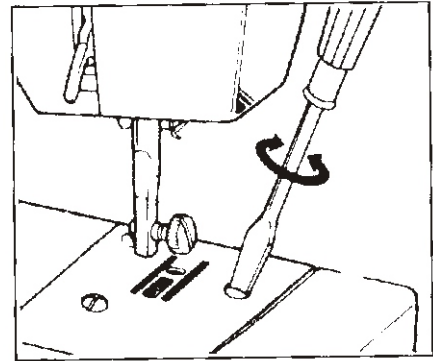

CLEANING THE SHUTTLE RACE

Unplug the machine from the power supply.

To remove shuttle:

Raise needle to its highest position and remove bobbin case. Turn levers away from shuttle and lift out retaining ring and shuttle, by grasping center pin. Clean the reverse side of feed dog with a small brush. Remove lint and thread from all parts of shuttle and wipe with a lightly oiled cloth.

To reassemble:

Hold shuttle by center pin and fit carefully back into shuttle race, forming perfect circle with shuttle driver. Replace retaining ring polished side out, making sure the bottom pin fits into notch. Lock retaining ring by turning levers back into position, Refit bobbin case with bobbin.

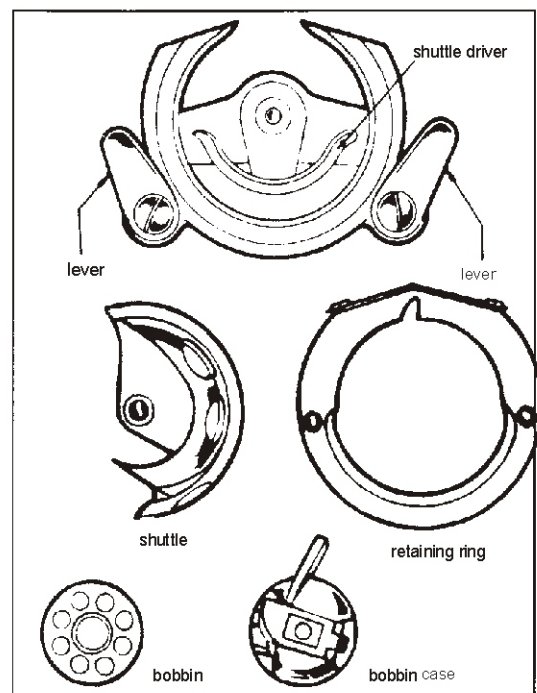

FREE ARM SEWING

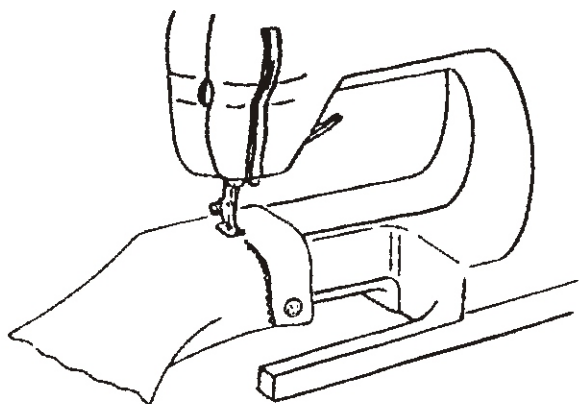

This sewing machine can be used like a flat bed machine, but easily converts to a free arm machine by removing the extension table. The free arm enables you to sew tubular types of pieces more easily. Just slip the sleeve or pants leg on the free arm as shown above. You will find many uses for this free arm feature such as:

1. Mend elbows and knees of garments more easily.
2. Sew in sleeves more easily. This is especially true when sewing smaller garments.
3. Applique, embroider or hem around edges of cuffs or pants legs.
4. Sew in elastic casings in skirts or pants at the waist line.

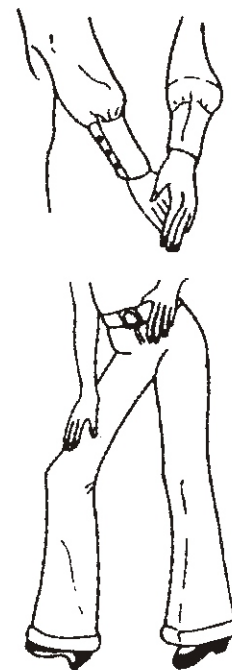

TROUBLE SHOOTING: CAUSES AND REMEDIES

THREAD FORMS LOOPS

CAUSE	REMEDY
Thread tension not properly regulated Needle thread properly threaded and/or bobbin thread not properly wound Thread size not suited to fabric Thread check spring not working properly	Read instructions for regulating needle-and bobbin thread tension Thread machine properly and/or wing bobbin thread correctly See Size of needle and thread Have spring replaced

SHRINKING OR PUCKERING OF THE SEAM

Tension too tight Sewing foot pressure too strong	Read instructions for regulating needle-and bobbin thread tensions Read instructions for regulating sewing foot pressure
--	---

IRREGULAR STITCHES

Needle and bobbin threads of poor quality Bobbin thread unevenly wound	Use top quality threads Re-wind bobbin
---	---

MACHINE DOES NOT RUN FREELY AND MAKES A NOLSE

Machine needs oiling Dust and thread in shuttle Wrong oil used, has now clogged machine Drive belt tension too tight	Read instructions on how to oil Read instructions on how to clean shuttle race Clean machine carefully and re-oil with top quality oil Loosen tension of drive belt
---	--

TROUBLE SHOOTING: CAUSES AND REMEDIES

NEEDLE THREAD BREAKS

CAUSE	REMEDY
Needle not properly threaded Thread tension too tight Something wrong with the needle Thread is too heavy for needle Thread check spring is broken Needle not properly inserted Needle plate, shuttle or sewing foot damaged	Thread properly loosen tension Replace needle Change Have a new spring fitted Insert needle properly Replace

BOBBIN THREAD BREAKS

Bobbin thread entangled because of incorrectly wound bobbin Bobbin thread not under tension spring on bobbin case	Wind bobbin correctly Thread bobbin correctly
--	--

STITCHES ARE LEFT OUT

Needle not properly fitted on needle bar Needle bent or blunt Needle worn	Fit needle properly Replace Replace
---	---

NEEDLE BREAKS

Needle bent Needle not properly fitted Fabric too heavy or too hard You are pulling on the fabric	Replace Fit needle properly Use needle of correct size Do not pull
--	---