

SL4635 & SL4835 Skid Loaders



OPERATOR'S MANUAL

GEHL®

INTERNATIONAL SYMBOLS





















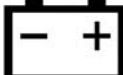





















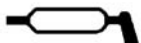

					
Engine Start	Engine Stop	Power On	Power Off	Work Light	Hazard Flasher
					
Horn	Volume - Full	Volume - Half Full	Volume - Empty	Battery Charge	Fuse
					
Read Operator's Manual	Engine Hourmeter	Diesel Fuel	Lift Point	Parking Brake	Neutral
					
Safety Alert	Transmission Temperature	Transmission Pressure	Hydraulic Oil Temperature	Hydraulic System	Engine Coolant
					
Engine Air Filter	Glow Plug	Engine Oil	Engine Oil Pressure	Engine Oil Level	Engine Oil Temperature
					
Machine Travel - Forward	Machine Travel - Reverse	Control Handles	Clockwise Rotation	Counterclockwise Rotation	Grease Lubrication Point
					
Seatbelt - Lap Only	Tie-Down	Fast	Slow	Bucket - Raise	Bucket - Float
					
Bucket - Lower	Bucket - Tilt	Bucket - Empty			

Table of Contents

Chapter	Description	Page
	International Symbols	inside front cover
1	Introduction	2
2	Model Specifications	4
3	Checklists	7
4	Safety	10
5	Controls & Safety Equipment	19
6	Operation	35
7	Adjustments	45
8	Lubrication	49
9	Troubleshooting	52
10	Service	59
11	Maintenance Schedule	74
	Index	78
	Torque Specifications	80
	Warranty	inside back cover

IDENTIFICATION INFORMATION

Write your Gehl loader model and serial numbers in the spaces provided below. Refer to these numbers when inquiring about parts or service from your Gehl dealer.

MODEL NO.

SL

SERIAL NO.

GEHL®

WEST BEND, WI 53095 U.S.A.

The model and serial numbers for this loader are on a decal located inside the right chassis riser, in front of the lift arm pivot.

All-Tach, Quick-Tach and Hydraloc are trademarks of Gehl Company.
 Gehl and Powerview are registered trademarks of Gehl Company.

CHAPTER 1

INTRODUCTION

This Operator's Manual gives the owner/operator information about maintaining and servicing SL4635, SL4635SX, SL4635SXT, SL4635DXT, SL4835SXT and SL4835DXT skid loader models. More importantly, this manual provides an operating plan for safe and proper use of the machine. Major points of safe operation are detailed in the *Safety* chapter of this manual.

The Gehl® Company asks that you read and understand the contents of this manual COMPLETELY and become familiar with your new machine BEFORE attempting to operate it. Contact your Gehl dealer to obtain extra manuals or manuals in other languages. A SAFETY VIDEO IS ALSO AVAILABLE for purchase through your Gehl dealer.

Throughout this manual, information is provided that is set *italic* type and introduced by the word NOTE or IMPORTANT. Be sure to read carefully and comply with the message. Following this information will improve your operating and maintenance efficiency, help avoid breakdowns and damage, and extend your machine's life.

A manual box in the ROPS/FOPS stores the Operator's Manual. After using the manual, please return it to the box and keep it with the unit at all times. If this machine is resold, Gehl Company recommends that this manual be given to the new owner.

The attachments and equipment available for use with this machine have a wide variety of potential applications. Read the manual provided with the attachment to learn how to safely maintain and operate the machine. Be sure the machine is suitably equipped for the type of work to be performed.

Do not use this machine for any application or purpose other than those described in this manual. If the machine is to be used with special attachments or equipment other than those approved by Gehl, consult your Gehl dealer. Any person making unauthorized modifications is responsible for the consequences.

“Right” and “left” are determined from a position sitting in the seat and facing forward. From this position:

If your loader is T-Bar controlled: The left T-Bar controls the wheel drives and the right T-Bar controls the lift and tilt.

If your loader is Hand & Foot controlled (either electric or mechanical auxiliary): The left handle controls the wheel drive on the left side of the machine. The right handle controls the wheel drive on the right side of the machine. The left foot pedal controls the lift. The right foot pedal controls the tilt.

If your loader is Dual Hand controlled: The left handle controls the wheel drive on the left side of the machine and the lift. The right handle controls the wheel drive on the right side of the machine and the tilt.

The use of skid steer loaders is subject to certain hazards that cannot be eliminated by mechanical means, but only by exercising intelligence, care and common sense. Such hazards include, but are not limited to, hillside operation, overloading, instability of the load, poor maintenance and using the equipment for a purpose for which it is not intended or designed.

It is essential to have competent and careful operators, who are not physically or mentally impaired, and who are thoroughly trained in the safe operation of the equipment and the handling of loads. It is recommended that the operator be capable of obtaining a valid motor vehicle operator's license.

Our dealership network stands by to provide you with any assistance you may require, including genuine Gehl service parts. All service parts should be obtained from your Gehl dealer. Give complete information about the part and include the model and serial numbers of your machine. Record these numbers in the space provided on the previous page, as a handy reference.

Gehl Company reserves the right to make changes and improvements in the design and construction of any part without incurring the obligation to install such changes on any unit previously delivered.

**The Gehl Company, in cooperation with the American Society
of Agricultural Engineers and the Society of Automotive Engineers,
has adopted this Safety Alert Symbol→**

to pinpoint precautions which, if NOT properly followed, can create a safety hazard. When you see this symbol in this manual or on the machine itself, you are reminded to BE ALERT! Your personal safety is involved!



Loader Identification

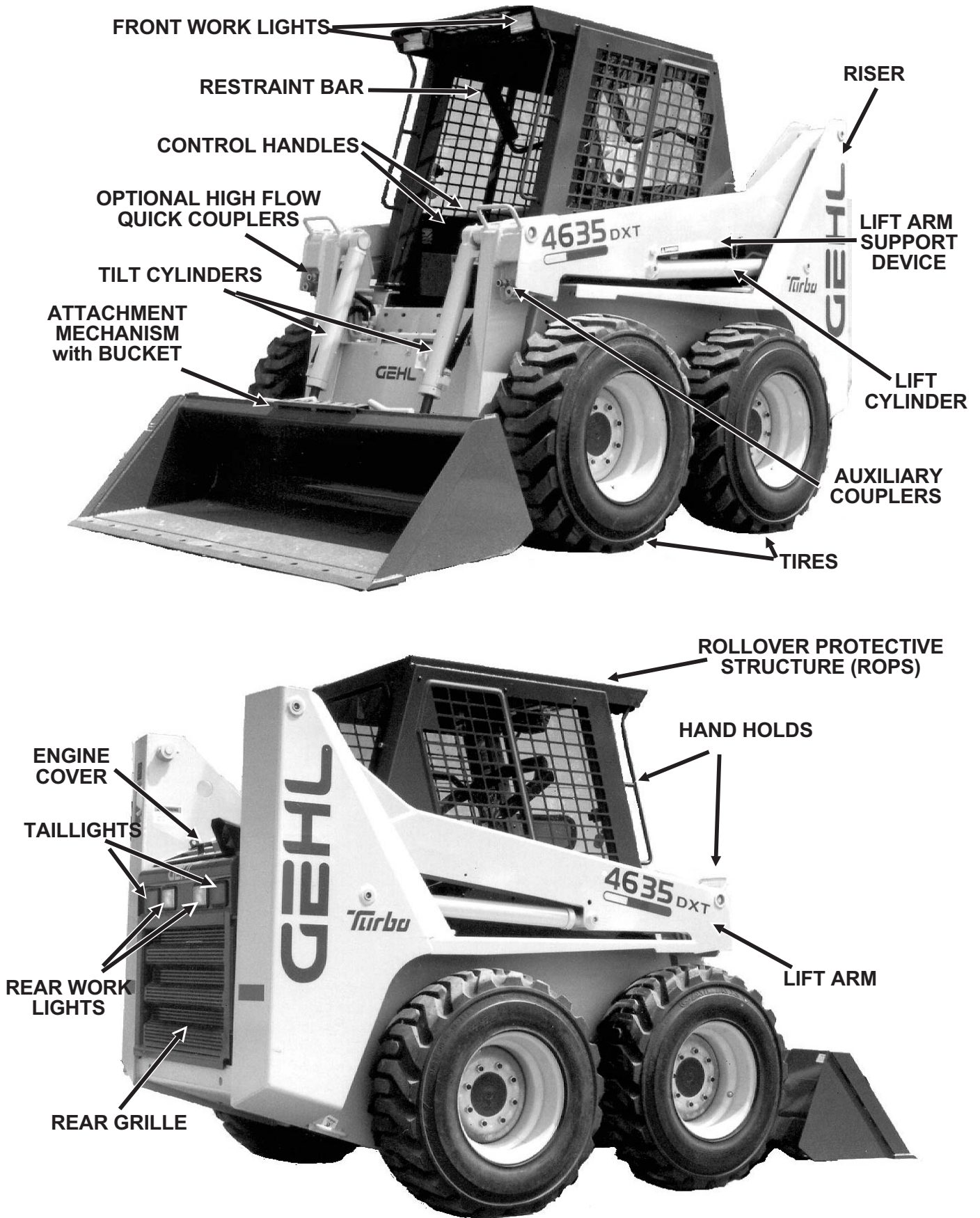

CHAPTER 2

MODEL SPECIFICATIONS

	SL4635 / SL4635SX	SL4635SXT / DXT	SL4835SXT / DXT
Engine:			
Make	Deutz	Deutz (Turbo)	Deutz (Turbo)
Model	F3M1011F	BF3M1011F	BF3M1011F
Fuel	Diesel	Diesel	Diesel
Displacement	133 CID (2,18 L)	133 CID (2,18 L)	133 CID (2,18 L)
Horsepower	44 hp (32,8 kW) @ 2600 rpm	57 hp (42,5 kW) @ 2500 rpm	57 hp (42,5 kW) @ 2500 rpm
Horsepower - Net (In accordance with ISO9249)	43 hp (32,1 kW) @ 2600 rpm	56hp (41,8 kW) @ 2500 rpm	56hp (41,8 kW) @ 2500 rpm
Torque - Maximum	103 ft-lbs (140 N·m) @ 1800 rpm	140 ft-lbs (190 N·m) @ 1800 rpm	140 ft-lbs (190 N·m) @ 1800 rpm
SAE Rated Operating Load¹	1425 lbs (646 kg)	1425 lbs (646 kg)	1625 lbs (737 kg)
Operating Weight	6100 lbs (2800 kg)	6100 lbs (2800 kg)	6300 lbs (2900 kg)
Shipping Weight	5200 lbs (2350 kg)	5200 lbs (2350 kg)	5300 lbs (2500 kg)
Fuel Tank Capacity	15 US gal (57 L)	15 US gal (57 L)	17 US gal (64 L)
Sound² (with Deluxe Sound Kit)			
Pressure Level (Operator Ear)	87 dB(A) ³	86 dB(A)	85 dB(A)
Power Level (Environmental)	102 dB(A) ³	102 dB(A)	102 dB(A) - SXT / 101 dB (A) - DXT

Specifications Below Apply To All SL4635 and SL4835 models

Capacities		Electrical	
Hydraulic Reservoir	12 US gal (45 L)	Battery	12 volt DC with 950 CCA min.
Chaincases (each)	8 US qts (7,6 L)	Starter	12 volt DC (2.3 kW)
Engine Oil	8.5 US qts (8 L)	Alternator	55 amperes
Hydraulic System (Theoretical)		Travel Speed 0 to 8.5 mph (0 to 13,7 km/h)	
Main Hydraulic System Pressure	2750 psi (190 bar)		
High-Flow Hydraulic System Pressure	2500 psi (172 bar)		
Standard Flow Rate (Single)	19 gpm (72 L/min)		
High-Flow Rate (Dual - DX models)	30 gpm (114 L/min)		

Tire Options

Narrow Width Heavy Duty Flotation tires	10 x 16.5 - 8 ply
Heavy Duty Fat Foot Flotation Tires	31 x 13.30 x 16.5
Heavy Duty Wide Sideways Flotation Tire Set	10 x 16.5 - 8 ply
Heavy Duty Wide Sideways Flotation Tire Set	12 x 16.5 - 10 ply
Solid Rubber tires	6.5 x 16
AirBoss Segmented Industrial tires	7.5 x 15
AirBoss Segmented Flotation tires	10 x 16.5

Buckets and Capacities

Width - inches (millimeters)	Bucket Description	Capacity (Heaped)	
60 inches (1520 mm)	Dirt/Construction	10.0 cubic feet	0.28 cubic meters
65 inches (1650 mm)	Dirt/Construction	10.8 cubic feet	0.31 cubic meters
65 inches (1650 mm)	Dirt/Construction	14.7 cubic feet	0.42 cubic meters
65 inches (1650 mm)	Utility	18.6 cubic feet	0.53 cubic meters
68 inches (1730 mm)	Dirt/Construction	15.3 cubic feet	0.43 cubic meters
68 inches (1730 mm)	Utility	19.0 cubic feet	0.54 cubic meters
72 inches (1830 mm)	Utility/Snow	32.0 cubic feet	0.91 cubic meters
72 inches (1830 mm)	Utility	27.0 cubic feet	0.76 cubic meters

¹Operating load rated with a 65 inch (1650 mm) dirt/construction bucket for an SL4635 or a 68 inch (1730 mm) dirt/construction bucket for an SL4835, 10 x 16.5 tires and a 175lb (79kg) operator, in accordance with SAE J818.

² Effective January 2000

³ SL4635SX Only

Specifications subject to change without notice.

STANDARD FEATURES

- ➔ Fuel Gauge
- ➔ Engine Oil Temperature Gauge and Light
- ➔ Hourmeter
- ➔ Oil Pressure Indicator Light
- ➔ Battery Charge Indicator Light
- ➔ Seat Belt Indicator Light and Buzzer
- ➔ Choice of three controls: Gehl T-Bar, Hand & Foot or Dual Hand
- ➔ Foot Throttle (T-Bar and Dual Hand Controls only)
- ➔ Acoustical Material and Headliner
- ➔ Operator Restraint Bar with Armrests
- ➔ Top and Rear Windows - ROPS
- ➔ Adjustable Seat
- ➔ ROPS-FOPS ISO Level II Approved
- ➔ Number 80E Drive Chain
- ➔ Dual Skid Plates with Cleanout (access) Covers
- ➔ Spark Arrestor Muffler (SL4635 & SL4635SX only)
- ➔ Hydraloc™ System - Brakes and Interlock for Starter, Lift Cylinders, Tilt Cylinders and Wheel Drives
- ➔ Visual Hydraulic Filter Indicator
- ➔ Dual Element Air Cleaner with Visual Indicator
- ➔ Vandalism Lock Provision
- ➔ Glow Plug Starting Assist
- ➔ High Gain Servo-Controlled Hydrostatic Drive
- ➔ Lift Arm Support Device
- ➔ Self-Leveling Lift Action
- ➔ Independent Steel Hydraulic Reservoir
- ➔ Dual Front & Rear Halogen Work Lights and Dual Taillights
- ➔ All-Tach™ Attachment Mounting System
- ➔ Front Auxiliary Hydraulics with Flat-Faced Couplers
- ➔ Powerview® Lift Arm
- ➔ Bi-directional High Flow Auxiliary Hydraulics (DXT only)

ACCESSORIES

- ➔ 3-inch wide Seat Belt - When Required by Law
- ➔ Sliding Side Windows
- ➔ Deluxe Sound Package
- ➔ Interior Dome Light
- ➔ Horn
- ➔ Rear View Mirror
- ➔ Suspension Seat
- ➔ Impact Resistant Front Door with Wiper
- ➔ Operator's Compartment Heater/Defroster
- ➔ Audible Back-Up Alarm
- ➔ Strobe Light
- ➔ Dual Flasher Kit
- ➔ Battery Disconnect Switch
- ➔ Engine Auto-Shutdown System
- ➔ Gehl-style Quick-Tach™ Attachment Mounting
- ➔ Bucket Bolt-On Cutting Edge Kits
- ➔ Lift Kit
- ➔ Rear Counterweight
- ➔ Hydraulic Couplers - Kit
- ➔ Centrifugal Pre-Cleaner
- ➔ Engine Oil Pan Heater

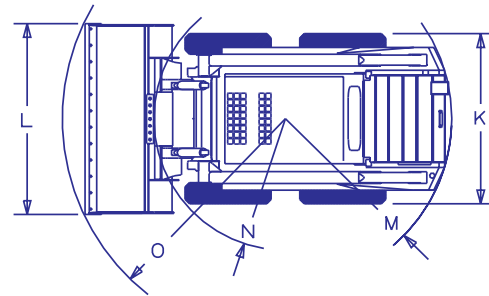
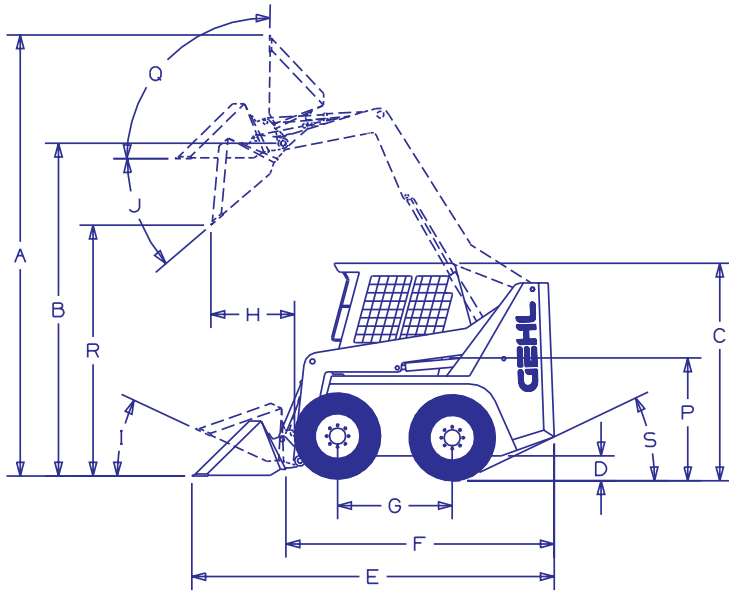

General Specifications

	SL4635		SL4835	
	inch	(mm)	inch	(mm)
A Overall Operation Height - Fully Raised	153.0	(3886)	153.0	(3886)
B Height to Hinge Pin - Fully Raised	115.0	(2921)	115.0	(2921)
C Overall Height - Top of ROPS	76.0	(1937)	76.0	(1937)
D Ground Clearance to Chassis (Between Wheels)	7.7	(197)	7.7	(197)
Ground Clearance to Chassis (Below Chaincase)	7.0	(178)	7.0	(178)
E Overall Length (w/65" Dirt/Construction Bucket Down)	121.2	(3080)		
Overall Length (w/68" Utility Bucket Down)			125.3	(3184)
F Overall Length (less Bucket)	89.5	(2273)	93.6	(2377)
G Wheel Base	37.0	(940)	41.1	(1044)
H Dump Reach-w/65" Dirt/Construction Bucket (full height)	27.6	(701)		
Dump Reach-w/68" Dirt/Construction Bucket (full height)			27.6	(701)
Dump Reach-w/65" Dirt/Construction Bucket (110" height)	29.0	(737)		
Dump Reach-w/68" Dirt/Construction Bucket (110" height)			29.0	(737)
I Rollback Angle at Ground	27°		27°	
J Dump Angle at Full Height	40°		40°	
K Overall Width-less Bucket (w/7.00 x 15 Tires)	58.5	(1486)	58.5	(1486)
Overall Width-less Bucket (w/10.00 x 16.5 Tires)	62.0	(1575)	62.0	(1575)
Overall Width-less Bucket (w/31.5 x 15.00 x 16.5 Tires)	67.5	(1715)	67.5	(1715)
L Bucket Width (65" Dirt-Construction Bucket) - Overall	67.0	(1702)		
Bucket Width (68" Dirt-Construction Bucket) - Overall			69.8	(1775)
M Clearance Circle - Rear	57.0	(1448)	59.0	(1499)
N Clearance Circle - Front (less Bucket)	46.0	(1168)	47.0	(1194)
O Clearance Circle - Front (w/65" Dirt/Construction Bucket)	77.0	(1956)		
Clearance Circle - Front (w/68" Utility Bucket)			79.5	(2019)
P Seat to Ground Height	34.5	(876)	34.5	(876)
Q Rollback Angle at Full Height	98°		98°	
R Dump Height (w/65" Dirt/Construction Bucket)	87.2	(2216)		
Dump Height (w/68" Dirt/Construction Bucket)			87.2	(2216)
S Departure Angle	28°		28°	
Reach Maximum (65" Dirt/Construction Bucket Tipped)	23.6	(599)		
Reach Maximum (68" Dirt/Construction Bucket Tipped)			23.6	(599)
Reach Maximum (65" Dirt/Construction Bucket Flat)	54.2	(1378)		
Reach Maximum (68" Dirt/Construction Bucket Flat)			54.2	(1378)
Dump Height at Maximum Reach (Floor to Cutting Edge - 65")	27.0	(686)		
Dump Height at Maximum Reach (Floor to Cutting Edge - 68")			27.0	(686)
Height to Top of Riser	66.7	(1695)	66.7	(1695)
Maximum Back Grading Angle	87°		87°	

CHAPTER 3

CHECKLISTS

PRE-DELIVERY

The following checklist is an important reminder of valuable information and inspections which **MUST** be made before delivering the loader to the customer. Check off each item after the prescribed action is taken.

Check that:

- Unit has NOT been damaged in shipment. Check for such things as dents and loose or missing parts; correct or replace components as required.
- Battery is securely mounted and NOT cracked. Cable connections are tight and battery disconnect switch (optional) is in the "ON" position.
- Lift and tilt cylinders, hoses and fittings are NOT damaged, leaking or loosely connected.
- Cooler hoses and fittings are NOT damaged, leaking or loosely connected.
- Filters are NOT damaged, leaking or loosely secured.
- Wheel nuts are torqued to 170-180 ft-lbs (231-244 N·m) and tires are properly inflated.
- Loader is properly lubricated and NONE of the grease fittings are missing or damaged.
- Hydraulic system reservoir, engine crankcase and drive chaincases are filled to their proper levels with oil.
- All adjustments are made to comply with settings given in the *Adjustments* chapter of this manual.
- All guards, shields and decals are in place and secured.
- Model and serial numbers for this unit are recorded in the space provided on this page and page 1.

Start the loader engine and test-run the unit while checking that proper operation is exhibited by all controls.

Check that:

- Drive control and lift/tilt control handle(s) or hand/foot controls operate properly and are NOT damaged or binding.
- Drive control handle(s) or hand/foot controls are properly adjusted for a correct "neutral" position.
- Hydraloc™ system functions properly. By design, the engine will NOT start unless the operator is sitting on the seat and the restraint bar is lowered. Furthermore, the lift and tilt circuits and wheel drives will not operate unless the operator is sitting on the seat, the restraint bar is lowered, and the starter key switch is in the "run" position.

I acknowledge that the pre-delivery procedures were performed on this unit as outlined above.

Dealership Name

Dealer Representative's Name

Date Checklist Filled-out

Loader Model#

Loader Serial#

Engine Serial#

DELIVERY

Check that:

The following checklist is an important reminder of valuable information that **MUST** be passed on to the customer at the time the unit is delivered. Check off each item as you explain it to the customer.

Review with the customer the contents of this manual, especially:

- The INDEX at the back, for quickly locating topics.
- The *Safety, Controls & Safety Equipment* and Operation chapters, for information regarding safe use of the machine.
- The *Adjustments, Lubrication, Service* and *Troubleshooting* chapters, for information regarding proper maintenance of the machine. Explain that regular lubrication and maintenance are required for continued safe operation and long life.
- Give this Operator's Manual to the customer and instruct the customer to be sure to read and completely understand its contents **BEFORE** operating the unit.
- Explain that the customer **MUST** consult the engine manual (provided) for related specifications, operating adjustments and maintenance instructions.
- Completely fill out the Owner's Registration, including customer's signature and return it to the Gehl company.

Customer's Signature

Date Delivered

(Dealer's File Copy)

INTENTIONALLY BLANK

(To be removed as Dealer's file copy)

CHAPTER 3

CHECKLISTS

PRE-DELIVERY

The following checklist is an important reminder of valuable information and inspections which **MUST** be made before delivering the loader to the customer. Check off each item after prescribed action is taken.

Check that:

- Unit has NOT been damaged in shipment. Check for such things as dents and loose or missing parts; correct or replace components as required.
- Battery is securely mounted and NOT cracked. Cable connections are tight and battery disconnect switch (optional) is in the “ON” position.
- Lift and tilt cylinders, hoses and fittings are NOT damaged, leaking or loosely connected.
- Cooler hoses and fittings are NOT damaged, leaking or loosely connected.
- Filters are NOT damaged, leaking or loosely secured.
- Wheel nuts are torqued to 170-180 ft-lbs (231-244 N·m) and tires are properly inflated.
- Loader is properly lubricated and NO grease fittings are missing or damaged.
- Hydraulic system reservoir, engine crankcase and drive chaincases are filled to their proper levels.
- All adjustments are made to comply with settings given in the *Adjustments* chapter of this manual.
- All guards, shields and decals are in place and secured.
- Model and serial numbers for this unit are recorded in the space provided on this page and page 1.

Start the loader engine and test-run the unit while checking that proper operation is exhibited by all controls.

Check that:

- Drive control and lift/tilt control handle(s) or hand & foot controls operate properly and are NOT damaged or binding.
- Drive control handle(s) or hand & foot controls are properly adjusted for a correct “neutral” position.
- Hydraloc™ system functions properly. By design, the engine will NOT start unless the operator is sitting on the seat and the restraint bar is “lowered”. Furthermore, the lift and tilt circuits and wheel drives will not operate unless the operator is sitting on the seat, the restraint bar is “lowered”, and the starter key switch is in the “run” position.

I acknowledge that pre-delivery procedures were performed on this unit as outlined above.

Dealership Name

Dealer Representative's Name

Date Checklist Filled-out

Loader Model#

Loader Serial#

Engine Serial#

DELIVERY

Check that:

The following checklist is an important reminder of valuable information that **MUST** be passed on to the customer at the time the unit is delivered. Check off each item as you explain it to the customer.

Review with the customer the contents of this manual, especially:

- The *Index* at the back, for quickly locating topics.
- The *Safety, Controls & Safety Equipment* and *Operation* chapters, for information regarding safe use of the machine.
- The *Adjustments, Lubrication, Service* and *Troubleshooting* chapters, for information regarding proper maintenance of the machine. Explain that regular lubrication and maintenance are required for continued safe operation and long life.
- Give this operator's manual to the customer and instruct the customer to be sure to read and completely understand its contents **BEFORE** operating the unit.
- Explain that the customer **MUST** consult the engine manual (provided) for related specifications, operating adjustments and maintenance instructions.
- Completely fill out the Owner's Registration, including customer's signature and return it to the Gehl company.

Customer's Signature

Date Delivered

(Pages 7 & 8 removed at perforation)

CHAPTER 4



SAFETY



The above Safety Alert Symbol means **ATTENTION! BECOME ALERT! YOUR SAFETY IS INVOLVED!** It stresses an attitude of “Heads Up for Safety” and can be found throughout this Operator’s Manual and on the machine itself.

Before you operate this equipment, read and study the following safety information. In addition, be sure that every one who operates or works with this equipment, whether family member or employee, is familiar with these safety precautions.

The Gehl Company **ALWAYS** considers the operator’s safety when designing its machinery, and guards exposed moving parts for the operator’s protection. However, some areas cannot be guarded or shielded in order to assure proper operation. Furthermore, this Operator’s Manual and the decals on the machine warn of additional hazards and should be read and observed closely.

Do not modify the ROPS/FOPS unless instructed to do so in options installations. Modifications such as welding, drilling or cutting can weaken the structure and reduce the protection it provides. A damaged ROPS/FOPS cannot be repaired - it must be replaced.

Different applications may require optional safety equipment, such as a back-up alarm, horn, mirror, strobe light or an impact-resistant front door. Be sure you know the job site hazards and equip your machine as needed.



“DANGER” indicates an imminently hazardous situation which, if not avoided, will result in death or serious injury.



“WARNING” indicates a potentially hazardous situation which, if not avoided, could result in death or serious injury.



“CAUTION” indicates a potentially hazardous situation which, if not avoided, may result in minor or moderate injury. May also alert against unsafe practices.

Mandatory Safety Shutdown Procedure

BEFORE cleaning, adjusting, lubricating, servicing the unit or leaving it unattended:

1. Move the drive control handle(s) to the “neutral” position.
2. Lower the lift arm and attachment completely. Also, see Step 4 below.
3. Move the throttle to the low idle position, shut off the engine and remove the key.
4. If the lift arm **MUST** be left in the “raised” position, **BE SURE** to properly engage the lift arm support device instead of performing Step 2.

ONLY after these precautions can you be sure it is safe to proceed. Failure to follow the above procedure could lead to death or serious injury.



Additional Safety Reminders

- Some photographs in this manual may show doors, guards and shields open or removed for illustrative purposes ONLY. BE SURE that all doors, guards and shields are in their proper operating positions BEFORE starting the engine to operate the unit.
- To ensure safe operation, replace damaged or worn-out parts with genuine Gehl service parts, BEFORE operating this equipment.
- Gehl skid loaders are designed and intended to be used ONLY with Gehl Company attachments or approved referral attachments. The Gehl Company cannot be responsible for operator safety if the loader is used with a non-approved attachment.
- The terrain, engine speed, load being carried, and abrupt control movements can affect machine stability. **IF MISUSED, ANY OF THE ABOVE FACTORS CAN CAUSE THE LOADER TO TIP, THROWING YOU FORWARD OR OUT OF THE UNIT, CAUSING DEATH OR SERIOUS INJURY.** Therefore, ALWAYS have the operator restraint bar lowered and wear the seat belt. Operate the controls smoothly and gradually at an appropriate engine speed that matches the operating conditions.
- For additional stability when operating on inclines or ramps, ALWAYS travel with the heavier end of the loader toward the top of the incline.
- DO NOT raise or drop a loaded bucket or fork suddenly. Abrupt movements under load can cause serious instability.
- NEVER attempt to by-pass the keyswitch to start the engine. Use only the jump-starting procedure detailed in the *Service* chapter of this manual.
- NEVER use your hands to search for hydraulic fluid leaks. Instead, use a piece of paper or cardboard. Escaping fluid under pressure can be invisible and can penetrate the skin and cause a serious injury. If any fluid is injected into your skin, see a doctor at once. Injected fluid MUST be surgically removed by a doctor or gangrene may result.
- NEVER use ether or starting fluid in an engine with glow plugs.
- Remove all trash and debris from the machine each day, especially in the engine compartment, to minimize the risk of fire.
- ALWAYS wear safety glasses with side shields when striking metal against metal. In addition, it is recommended that a softer (chip resistant) material be used to cushion the blow. Failure to heed could lead to serious injury to the eyes or other parts of the body.
- NEVER push the lift/tilt T-Bar control into the “float” position with the bucket or attachment loaded or raised, because this will cause the lift arm to lower rapidly.
- DO NOT drive too close to an excavation or ditch; BE SURE that the surrounding ground has adequate strength to support the weight of the loader and the load.
- DO NOT smoke or have any spark producing equipment in the area while filling the fuel tank or while working on the fuel or hydraulic systems.
- NEVER carry riders. Do not allow others to ride on the machine or attachments, because they could fall or cause an accident.
- ALWAYS look to the rear before backing up the skid loader.
- Operate the controls only from the operator’s seat.
- ALWAYS face the loader and use the hand holds and steps when getting on or off the loader. DO NOT jump off the loader.
- Be sure all persons are away from machine and give a warning before starting engine.
- DO NOT exceed the rated operating load of the machine.
- Exhaust fumes can kill. Do not operate this machine in an enclosed area unless there is adequate ventilation.
- When you park the machine and before you leave the seat, check the restraint bar for proper operation. The restraint bar, when raised, applies the parking brake and deactivates the lift/tilt controls.



SAFETY



WARNING

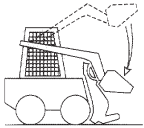

ALWAYS USE MECHANICAL LOCK WHEN LEAVING LIFT ARM IN THE RAISED POSITION FOR SERVICING LOADER.

BEFORE SERVICING LOADER, PROCEED AS SPECIFIED IN THE OPERATOR'S MANUAL.

FAILURE TO HEED COULD RESULT IN DEATH OR SERIOUS INJURY.

WARNING



OPERATING CONDITIONS COULD PRODUCE JERKY MOVEMENT.

BEFORE STARTING ENGINE FASTEN SEAT BELT.

FAILURE TO HEED COULD RESULT IN DEATH OR SERIOUS INJURY.

WARNING



PINCH POINT BETWEEN LIFT ARM AND LEDGE.

KEEP FEET INSIDE COMPARTMENT AND OFF LEDGE.

FAILURE TO HEED COULD RESULT IN DEATH OR SERIOUS INJURY.

WARNING



BEFORE OPERATING WITH ATTACHMENT, CHECK LOCKING PIN ENGAGEMENT OF THE QUICK-TACH TO THE ATTACHMENT.

FAILURE TO HEED COULD RESULT IN DEATH OR SERIOUS INJURY.

122718

129258





SAFETY



 **WARNING**

ROTATING OR HOT COMPONENTS CAN CAUSE INJURY

KEEP ENGINE COVER CLOSED WHILE ENGINE IS RUNNING

FAILURE TO HEED COULD RESULT IN DEATH OR SERIOUS INJURY

129130

129130

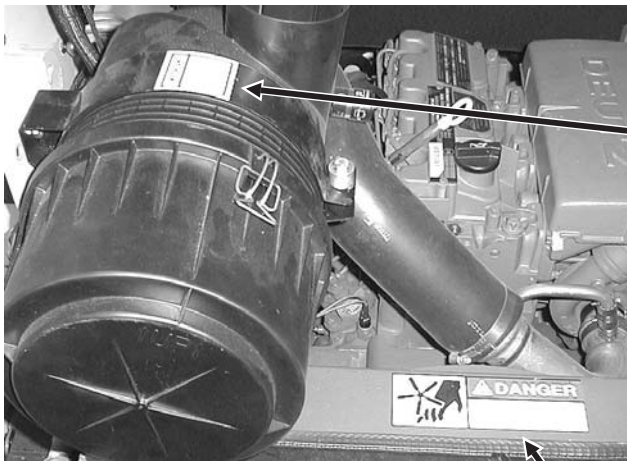

IMPORTANT

DO NOT USE ETHER OR OTHER STARTING FLUIDS TO START THIS ENGINE. WARRANTY MAY BE VOIDED.

114316

114316

 **DANGER**

KEEP HANDS OUT. ROTATING COMPONENTS CAN CUT HANDS. FAILURE TO HEED WILL RESULT IN DEATH OR SERIOUS INJURY.

091050

091050



SAFETY



⚠ DANGER



MAINTAIN SAFE CLEARANCE FROM ELECTRIC POWER LINES AND AVOID CONTACT WITH ANY ELECTRICALLY CHARGED CONDUCTOR.

CONTACT WITH ELECTRICAL POWER SOURCE CAN RESULT IN ELECTRICAL SHOCK OR ELECTROCUTION.

FAILURE TO HEED WILL RESULT IN DEATH OR SERIOUS INJURY.

093202

⚠ WARNING

KEEP ALL GUARDS AND SHIELDS IN PLACE. KEEP HANDS, FEET, AND ARMS INSIDE ENCLOSURE WHILE ENGINE AND MACHINE ARE OPERATING AND AWAY FROM POWER DRIVEN COMPONENTS. KEEP CHILDREN AND BYSTANDERS OFF AND AWAY FROM MACHINE. DO NOT WEAR LOOSE OR BAGGY CLOTHING WHILE OPERATING OR SERVICING MACHINE.

WEAR PROPER PERSONAL SAFETY GEAR CALLED FOR BY JOB OR CONDITIONS.

DO NOT START ENGINE OR OPERATE LOADER OR ATTACHMENT CONTROLS FROM ANY POSITION OTHER THAN PROVIDED.

DO NOT OPERATE MACHINE IN ENCLOSED AREA WITHOUT PROPER VENTILATION.

TRAVEL SLOWLY OVER ROUGH TERRAIN WHEN RAISING LIFT ARM AND APPROACHING DUMP AREA. NEVER MAKE SHARP MANUEVERS WITH LIFT ARMS RAISED.

BEFORE LEAVING OPERATOR'S SEAT, LOWER LIFT ARMS AGAINST FRAME, STOP ENGINE AND ENGAGE PARKING BRAKE.

IF LIFT ARMS MUST BE LEFT IN RAISED POSITION, ALWAYS INSTALL LIFT ARM LOCK.

DO NOT CHANGE BUCKET WITH LIFT ARMS RAISED.

ESCAPING FLUID UNDER PRESSURE CAN BE INVISIBLE AND CAN PENETRATE SKIN. DO NOT USE HANDS TO SEARCH FOR LEAKS. RELIEVE PRESSURE PRIOR TO DISCONNECTING. HYDRAULIC LINES AND COMPONENTS CAN BE HOT. DO NOT TOUCH.

NEVER SMOKE WHILE FILLING FUEL OR WORKING ON FUEL OR HYDRAULIC SYSTEM.

FAILURE TO HEED COULD RESULT IN DEATH OR SERIOUS INJURY.

093474



SAFETY



! DANGER

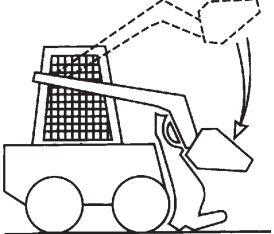

DO NOT WORK UNDER LIFT ARMS WHEN RAISED UNLESS SUPPORTED BY LIFT ARM STOP WITH ENGINE STOPPED.

REMOVING HOSES OR COMPONENT FAILURE CAN CAUSE LIFT ARMS TO DROP.

FAILURE TO HEED WILL RESULT IN DEATH OR SERIOUS INJURY.

091035



! WARNING



THE OWNER IS RESPONSIBLE FOR MAKING INFORMATION AVAILABLE TO THE OPERATOR ON THE SAFE USE AND PROPER MAINTENANCE OF THIS MACHINE.

DO NOT START, OPERATE, OR WORK ON THIS MACHINE UNTIL YOU READ AND UNDERSTAND THE CONTENTS OF THE OPERATOR'S MANUAL.

IF YOU HAVE QUESTIONS ON OPERATION ADJUSTMENT OR MAINTENANCE OF THIS MACHINE OR NEED AN OPERATOR'S MANUAL, OR IF ANY DECALS ARE NOT READABLE, CONTACT YOUR GEHL DEALER OR GEHL COMPANY, WEST BEND, WISCONSIN 53095 MODEL AND SERIAL NUMBERS WILL BE REQUIRED.

FAILURE TO HEED COULD RESULT IN DEATH OR SERIOUS INJURY.

093367





SAFETY

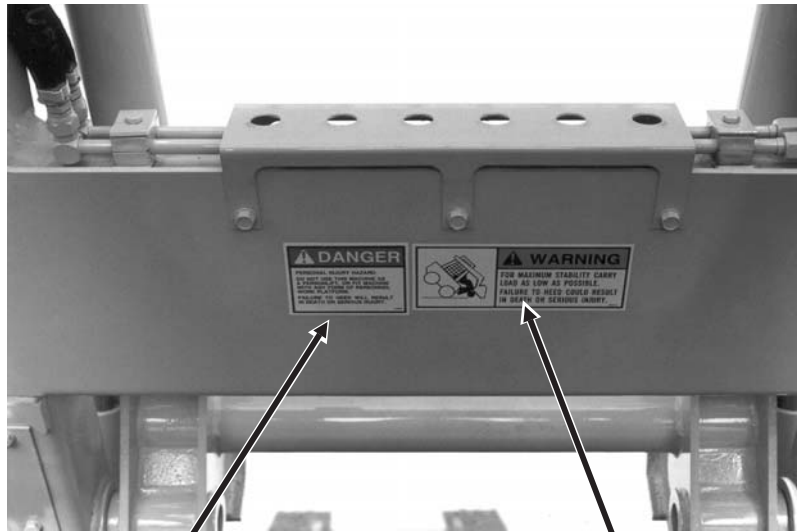

! DANGER

PERSONAL INJURY HAZARD.
DO NOT USE THIS MACHINE AS A PERSONLIFT, OR FIT MACHINE WITH ANY FORM OF PERSONNEL WORK PLATFORM.
FAILURE TO HEED WILL RESULT IN DEATH OR SERIOUS INJURY.

L65928

L65928

! WARNING



FOR MAXIMUM STABILITY CARRY LOAD AS LOW AS POSSIBLE.
FAILURE TO HEED COULD RESULT IN DEATH OR SERIOUS INJURY.

093479

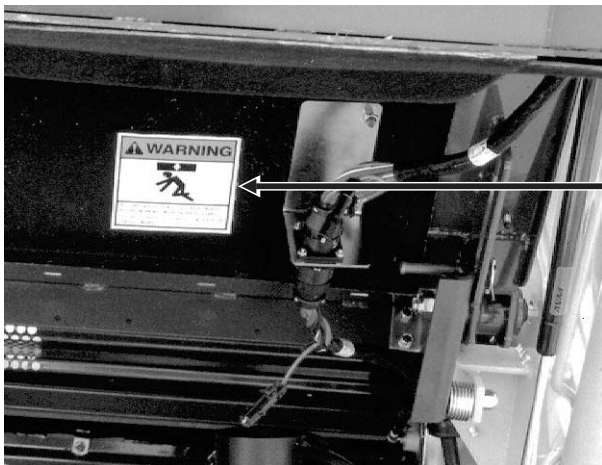

! WARNING



BE SURE SAFETY LOCK IS SECURELY ENGAGED BEFORE WORKING UNDER OVERHEAD GUARD.
FAILURE TO HEED COULD RESULT IN DEATH OR SERIOUS INJURY.

093477



SAFETY



! DANGER REMOVING HOSES OR COMPONENT FAILURE CAN CAUSE LIFT ARMS TO DROP
 USE MECHANICAL LOCK WHEN LEAVING LIFT ARM IN RAISED POSITION FOR SERVICE
 FAILURE TO HEED WILL RESULT IN DEATH OR SERIOUS INJURY

129132

129132



! WARNING

GAS-CHARGED SPRING CYLINDERS ARE USED ON THIS MACHINE. SEE OPERATOR'S MANUAL FOR LOCATIONS.

CYLINDERS HAVE HIGH INTERNAL PRESSURE. DO NOT DISASSEMBLE. DISASSEMBLY COULD RELEASE PARTS WITH GREAT FORCE.

FAILURE TO HEED COULD RESULT IN DEATH OR SERIOUS INJURY.

122745





SAFETY



! WARNING FOR MAXIMUM STABILITY CARRY LOAD AS LOW AS POSSIBLE.
FAILURE TO HEED COULD RESULT IN DEATH OR SERIOUS INJURY.

093475

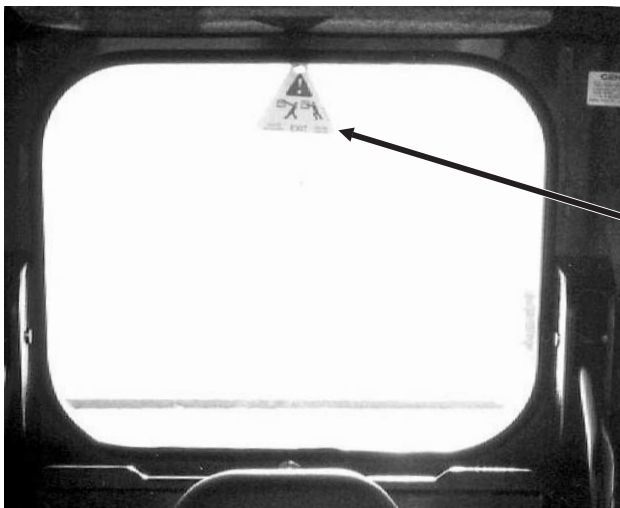
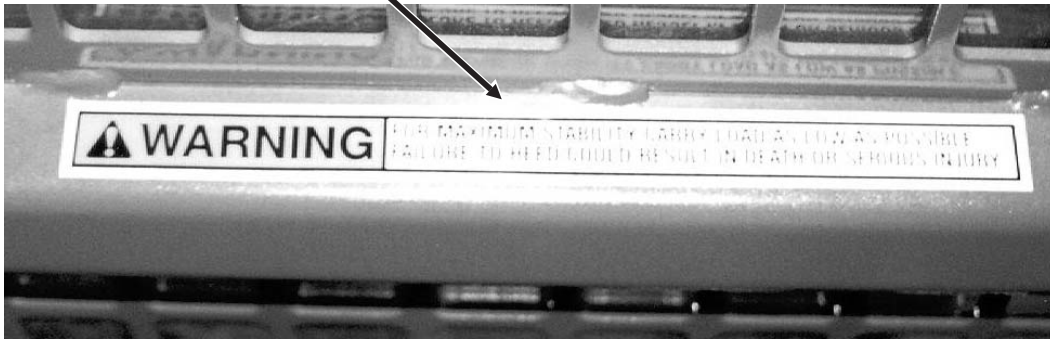

132166

CHAPTER 5

CONTROLS & SAFETY EQUIPMENT

CAUTION

Become familiar with and know how to use **ALL** safety devices and controls on the skid loader **BEFORE** operating it. Know how to stop loader operation **BEFORE** starting it. This Gehl skid loader is designed and intended to be used **ONLY** with a Gehl Company attachment or a Gehl Company approved accessory or referral attachment. The Gehl Company cannot be responsible for safety if the loader is used with a non-approved attachment.

Guards and Shields

Whenever possible and without affecting loader operation, guards and shields are used to protect potentially hazardous areas. In many places, decals are also provided to warn of potential dangers and/or to display special operating procedures.

WARNING

Read and thoroughly understand **ALL** safety decals on the loader **BEFORE** operating it. **DO NOT** operate the loader unless **ALL** factory-installed guards and shields are properly secured in place.

Controls

Your loader could be equipped with either “T-Bar,” “Hand & Foot” or “Dual Hands” controls. Hand & Foot controls can be equipped with either electric or mechanical auxiliary controls. Follow the instructions appropriate for your loader type.

Throttle Lever and Accelerator Pedal (Fig. 5-1)

A right-hand controlled throttle lever is provided on all models for adjusting the engine RPM.

A right-foot operated accelerator pedal on the T-Bar and Dual Hand controlled loaders controls the engine RPM to match increased power requirements. The pedal linkage is spring-loaded to return to the adjusted hand-operated throttle setting.

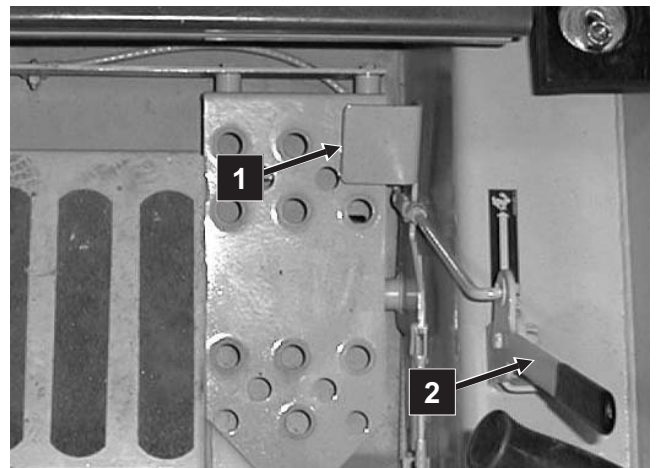

Fig. 5-1

1. Accelerator Pedal
2. Hand Throttle

T-BAR CONTROLLED LOADERS (Fig. 5-2)

T-Bars on the skid loader control the hydraulic and hydrostatic functions. The left T-Bar controls the drive (hydrostatics) and the right T-Bar controls the lift/tilt (hydraulics).

Drive Control T-Bar

The left T-Bar is the drive control which is linked to the hydrostatic drives.

Forward Travel: Push the left T-Bar straight forward (without twisting).

Reverse Travel: Pull the left T-Bar straight backwards (without twisting).

Turning during Travel: Twist the left T-Bar clockwise (to turn right) or counterclockwise (to turn left) and move it slightly forward or rearward to cause a slow gradual turn. The farther the T-Bar is moved in any direction, the faster the turn will be made. Engine RPM has a directly proportional affect on movement.

Fast Turning (Pivoting): Twist the left T-Bar clockwise to cause a spin turn to the right; twist the T-Bar counterclockwise to cause a spin turn to the left. On a spin turn, the wheels opposite the direction of the turn will rotate forward and the wheels on the same side as the direction of the turn will rotate rearward.

Auxiliary Hydraulics: Depress the foot pedal to control the direction of flow. A stop locks the foot pedal in the “on” (detent) position for continuous use.

WARNING

BE SURE the T-Bar controls are in “neutral” **BEFORE** starting the engine. Operate the T-Bars gradually and smoothly. Excessive speed and quick T-Bar movements without regard for conditions and circumstances is hazardous and could cause an accident.

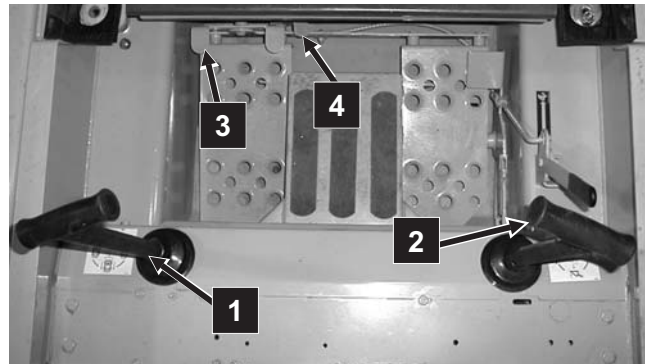

Fig. 5-2: T-Bar Controls

1. Drive Control T-Bar
2. Lift/Tilt T-Bar
3. Auxiliary Hydraulics Foot Pedal
4. Auxiliary Hydraulics Foot Pedal Stop

Lift/Tilt Control T-Bar

The right T-Bar controls the lift (arm) and tilt (attachment) through linkage to the main hydraulic control valve.

Attachment Travel: Twist the right T-Bar clockwise to tilt the attachment downward; twist it counterclockwise to tilt the attachment up or back.

Lift Arm Travel: **To raise** the lift arm: Pull the right T-Bar straight back (without twisting).

To lower the lift arm: Push the right T-Bar straight forward (without twisting).

The system control valve lift spool has a detent circuit allowing the lowered lift arm to “float” while traveling over changing ground conditions. To place the lift arm in the detent (float) position: Push the right T-Bar all the way forward, past the detent.

WARNING

NEVER push the lift/tilt T-Bar control into the “float” position with the bucket or attachment loaded or raised, because this will cause the lift arm to lower rapidly.

NOTE: The speed of lift/tilt motion is directly proportional to the amount of T-Bar movement and engine RPM.

T-BAR CONTROLS

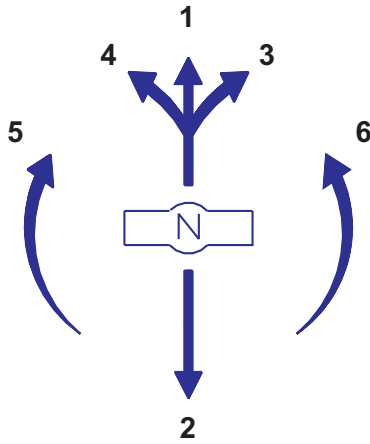

LEFT T-BAR CONTROL

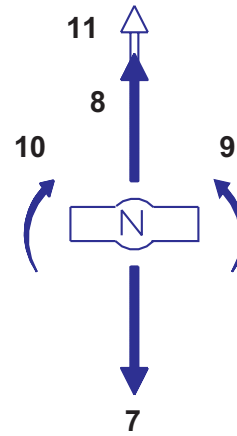

RIGHT T-BAR CONTROL

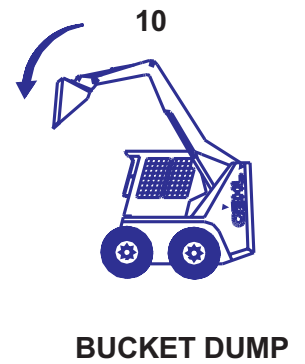
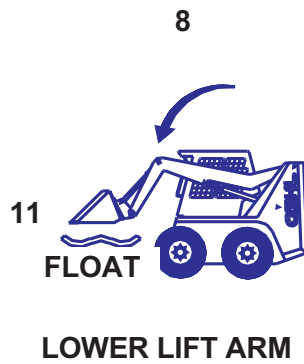
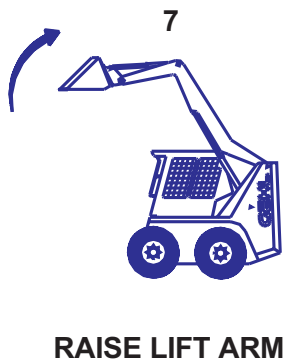
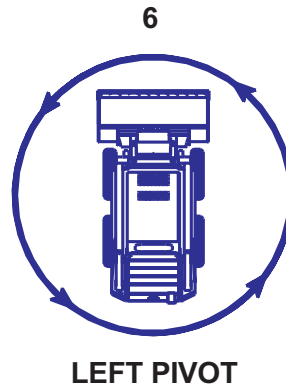
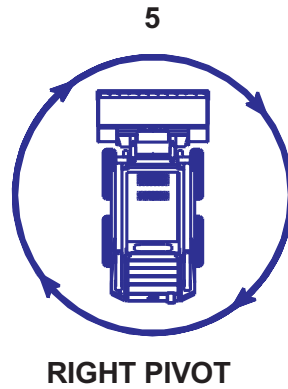
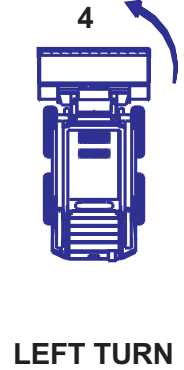
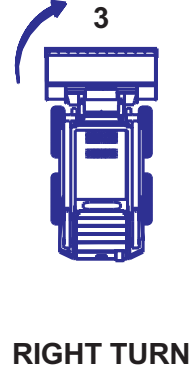
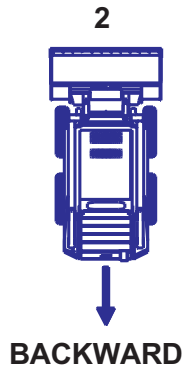
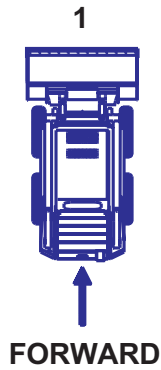

HAND & FOOT CONTROLLED LOADERS

with *ELECTRIC* AUXILIARY HYDRAULICS (Fig. 5-3)

Handles on the skid loader control the drive (hydrostatic) functions. The foot pedals control the lift/tilt (hydraulic) functions.

Drive Control Handles

NOTE: Moving the handles equally in the same direction will result in traveling straight forward or straight backward.

Forward Travel: Push both handles straight forward, slowly in the same direction.

Reverse Travel: Pull both handles straight backward, slowly in the same direction.

Turning during Travel: Move one handle farther forward or rearward than the other handle. Turn direction is determined by which handle is moved the farthest forward; to turn left, move the right handle farther forward than the left handle.

Fast Turning (Pivoting): Move the handles in opposite directions. Direction of travel is determined by which handle is moved forward; left handle forward turns the loader to the right, right handle forward turns the loader to the left.

Electric Auxiliary Hydraulic Switch: A switch (momentary) is located on the right handle. It has three positions: On-Off-On. An additional switch (detent) is located on the instrument panel for continuous operation in either direction.

WARNING

BE SURE the handles are in “neutral” **BEFORE** starting the engine. Operate handle controls gradually and smoothly. Excessive speed and quick handle movements without regard for conditions and circumstances is hazardous and could cause an accident.

Lift/Tilt Foot Pedals

Attachment Travel: The right foot pedal controls the tilting motion of the attachment. To tilt the attachment rearward, use your heel to push down on the rear of the right pedal; to tilt the attachment forward, use your toes to push down on the front of the right pedal.

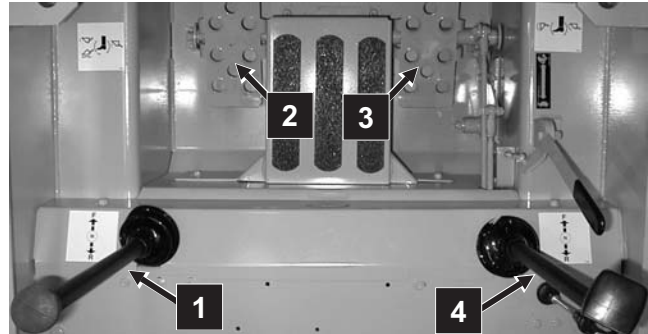

Fig. 5-3: Hand & Foot Controls with Electric Auxiliary Hydraulics

1. Left Drive Control Handle
2. Lift Control Foot Pedal
3. Tilt Control Foot Pedal
4. Right Drive Control Handle & Electric Auxiliary Hydraulic Switch

Lift Arm Travel: The left foot pedal controls the raising and lowering motion of the lift arm.

To raise the lift arm, use your heel to push down on the rear of the left foot pedal.

To lower the lift arm, use your toes to push down on the front of the left pedal.

The system control valve lift spool has a detent circuit allowing the lowered lift arm to “float” while traveling over changing ground conditions. To place the lift arm in the detent (float) position, use your toes to push the left foot pedal all the way down, past the detent.

WARNING

NEVER push the left foot pedal into the “float” position with the bucket or attachment loaded or raised, because this will cause the lift arm to lower rapidly.

NOTE: The speed of lift/tilt motion is directly proportional to the amount of foot pedal movement and engine RPM.

HAND & FOOT CONTROLS

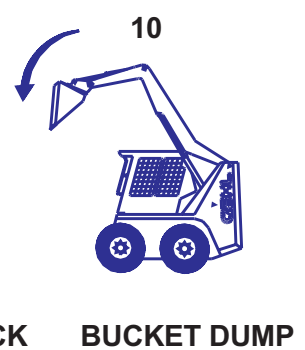
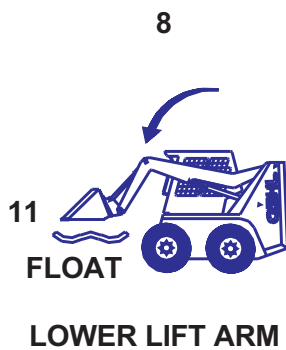
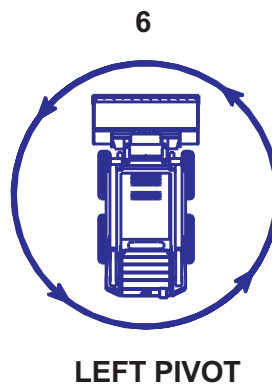
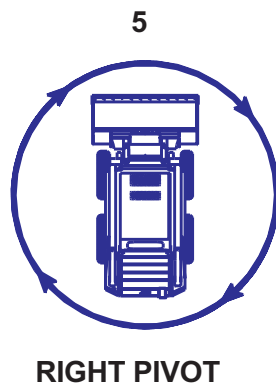
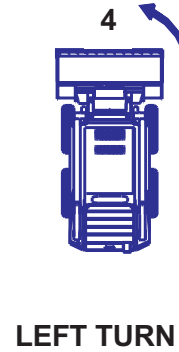
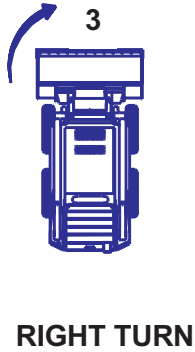
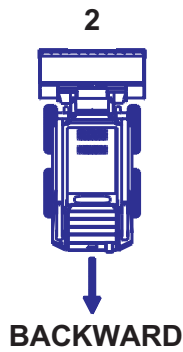
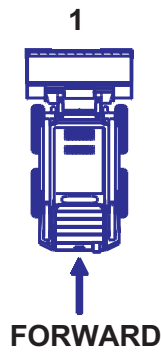
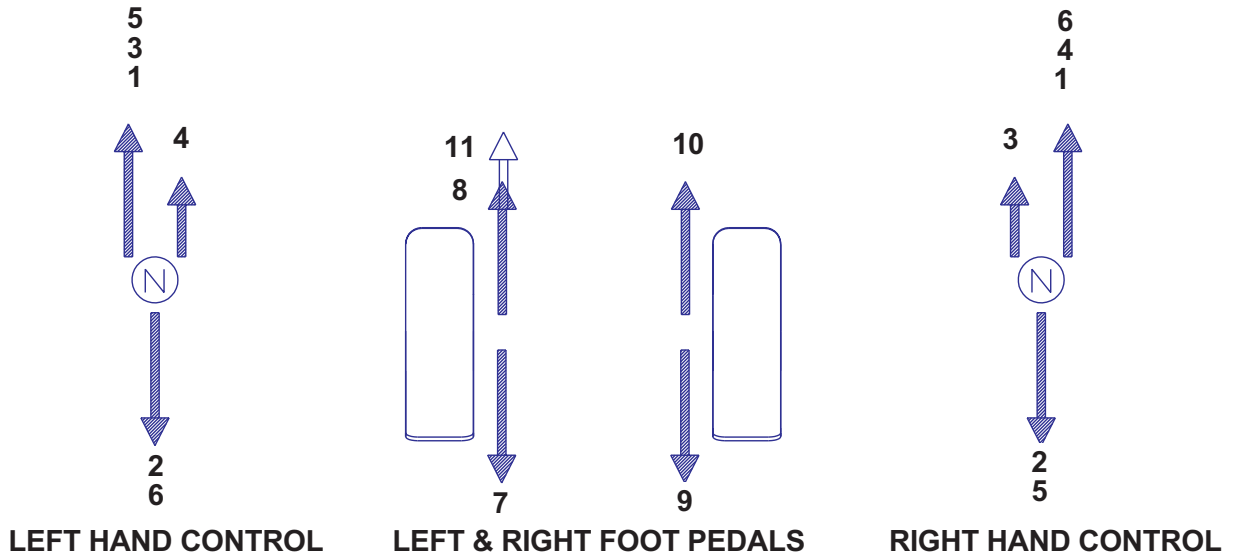

HAND & FOOT CONTROLLED LOADERS

with *MECHANICAL* AUXILIARY HYDRAULICS (Fig. 5-4)

Handles on the skid loader control the drive (hydrostatic) functions. The foot pedals control the lift/tilt (hydraulic) functions.

Drive Control Handles

NOTE: Moving the handles equally in the same direction will result in traveling straight forward or straight backward.

Forward Travel: Push both handles straight forward, slowly in the same direction.

Reverse Travel: Pull both handles straight backward, slowly in the same direction.

Turning during Travel: Move one handle farther forward or rearward than the other handle. Turn direction is determined by which handle is moved the farthest forward; to turn left, move the right handle farther forward than the left handle.

Fast Turning (Pivoting): Move the handles in opposite directions. Direction of travel is determined by which handle is moved forward; left handle forward turns the loader to the right, right handle forward turns the loader to the left.

Mechanical Auxiliary Hydraulic Control: Rotate the right handle up to activate the auxiliary hydraulics. Rotate the handle down to reverse the hydraulics. To lock the handle in the up direction, slide the pin in the side of the handle up.

WARNING

BE SURE the handles are in “neutral” **BEFORE** starting the engine. Operate handle controls gradually and smoothly. Excessive speed and quick handle movements without regard for conditions and circumstances is hazardous and could cause an accident.

Lift/Tilt Foot Pedals

Attachment Travel: The right foot pedal controls the tilting motion of the attachment. To tilt the attachment rearward, use your heel to push down on the rear of the right pedal; to tilt the attachment forward, use your toes to push down on the front of the right pedal.

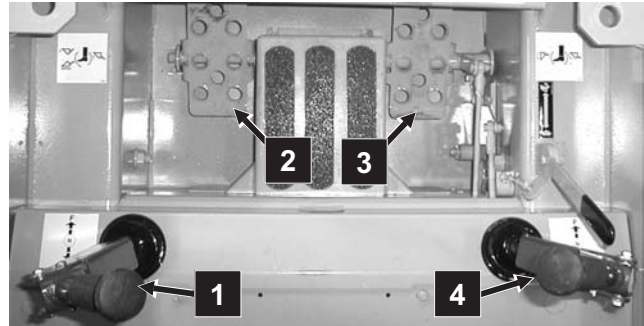

Fig. 5-4: Hand & Foot Controls with Mechanical Auxiliary Hydraulics

1. Left Drive Control Handle
2. Lift Control Foot Pedal
3. Tilt Control Foot Pedal
4. Right Drive Control Handle & Mechanical Auxiliary Hydraulic Control

Lift Arm Travel: The left foot pedal controls the raising and lowering motion of the lift arm.

To raise the lift arm, use your heel to push down on the rear of the left foot pedal.

To lower the lift arm, use your toes to push down on the front of the left pedal.

The system control valve lift spool has a detent circuit allowing the lowered lift arm to “float” while traveling over changing ground conditions. To place the lift arm in the detent (float) position, use your toes to push the left foot pedal all the way down, past the detent.

WARNING

NEVER push the left foot pedal into the “float” position with the bucket or attachment loaded or raised, because this will cause the lift arm to lower rapidly.

NOTE: The speed of lift/tilt motion is directly proportional to the amount of foot pedal movement and engine RPM.

HAND & FOOT CONTROLS

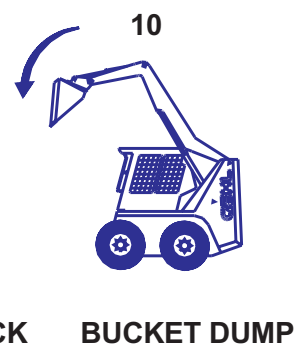
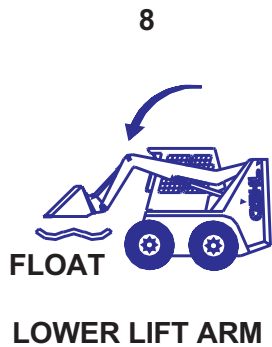
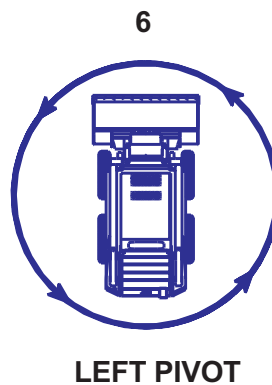
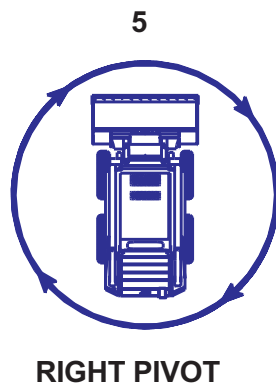
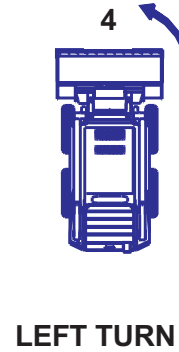
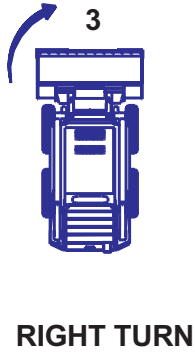
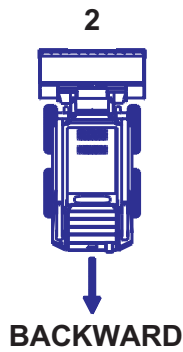
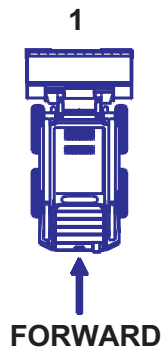
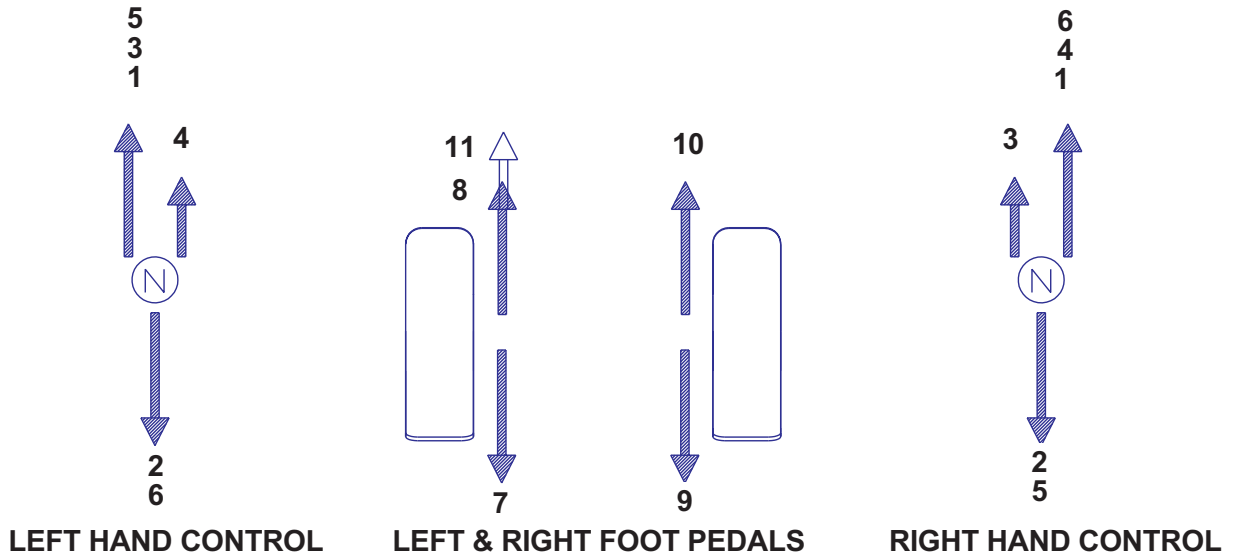

DUAL HAND CONTROLLED LOADERS (Fig. 5-5)

Handles with pivoting grips on the skid loader control the hydraulic and hydrostatic function. The right handle controls the right side drive and the tilt. The left handle controls the left side drive and the lift.

Drive Control Handles

NOTE: Moving the handles equally in the same direction will result in traveling straight forward or straight backward.

Forward Travel: Push both handles straight forward, slowly in the same direction.

Reverse Travel: Pull both handles straight backward, slowly in the same direction.

Turning during Travel: Move one handle farther forward or rearward than the other handle. Turn direction is determined by which handle moves the farthest forward; to turn left, move the right handle farther forward than the left handle.

Fast Turning (Pivoting): Move the handles in opposite direction of each other. The direction of travel is determined by which handle is moved forward; the left handle forward turns the loader to the right, the right handle forward turns the loader to the left.

Auxiliary Hydraulics: Depress the foot pedal to control the direction of flow. A stop locks the foot pedal in the “on” (detent) position for continuous use.

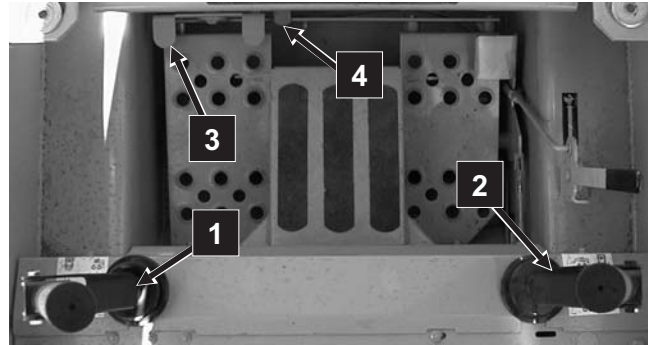

Fig. 5-5: Dual Hand Controls

1. Left Drive/Lift Control Handle
2. Right Drive/Tilt Control Handle
3. Auxiliary Hydraulics Foot Pedal
4. Auxiliary Hydraulics Foot Pedal Stop

Lift/Tilt Control Handles

Attachment Travel: To tilt an attachment upward, rotate the right handle down. To tilt an attachment downward, rotate the right handle up.

Lift Arm Travel: The left handle controls the raising and lowering motion of the lift arm.

To raise the lift arm, rotate the left handle up.

To lower the lift arm, rotate the left handle down.

The system control valve lift spool has a detent circuit allowing the lowered lift arm to “float” while traveling over changing ground conditions. To place the lift arm in the detent (float) position, push the left handle all the way down, past the detent.

WARNING

BE SURE the control handles are in “neutral” **BEFORE** starting the engine. Operate controls gradually and smoothly. Excessive speed and quick handle movements without regard for conditions and circumstances is hazardous and could cause an accident.

WARNING

NEVER push the lift/tilt handle into the “float” position with the bucket or attachment loaded or raised, because this will cause the lift arm to lower rapidly.

NOTE: The speed of lift/tilt motion is directly proportional to the amount of handle movement and engine RPM.

DUAL HAND CONTROLS



LEFT HANDLE CONTROL

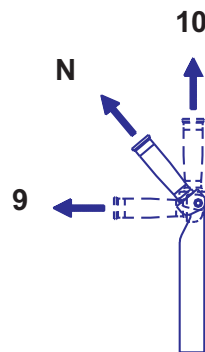
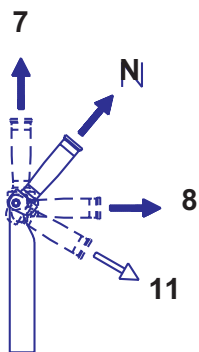

RIGHT HANDLE CONTROL

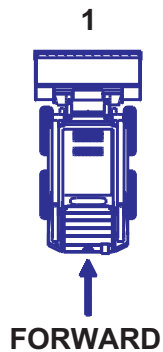

FORWARD

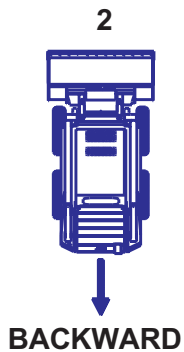

BACKWARD

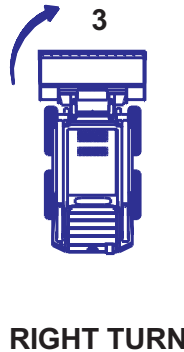

RIGHT TURN

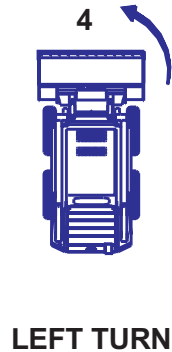

LEFT TURN

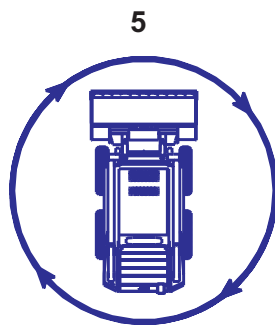

RIGHT PIVOT

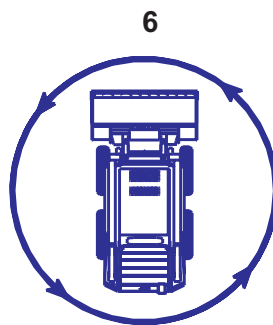

LEFT PIVOT

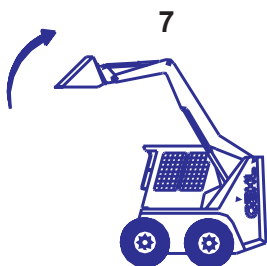

RAISE LIFT ARM

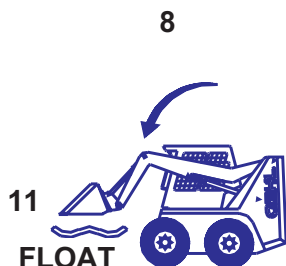

LOWER LIFT ARM



BUCKET ROLLBACK

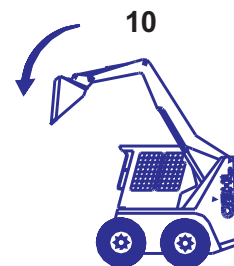

BUCKET DUMP

**Automatic Parking Brake
(Fig. 5-6)**

This skid loader is equipped with a spring applied hydraulic release parking brake. The parking brake engages when the operator lifts the restraint bar, leaves the operator's seat, and/or shuts the engine off. The brake can also be applied manually using the switch located on the left control panel of the ROPS. The red indicator on the switch lights up when the parking brake is applied.

**Operator Restraint Bar
(Fig. 5-7)**

The operator restraint bar is securely anchored to the ROPS. The restraint bar switch is wired in series with the seat switch forming an interlock for the lift arm, tilt, drive and starter circuits (refer to the "Interlock System" topic in this chapter for more information).

Lower the restraint bar after entering the operator's compartment. Used in conjunction with the seat belt, the restraint bar serves to keep you in the operator's compartment. For operator comfort and convenience, the restraint bar is padded for use as an arm rest while operating the loader.

! WARNING

NEVER defeat the operator restraint bar or seat switch electrically or mechanically, and **ALWAYS** wear your seat belt.

Seat Positioning (Fig. 5-7)

The loader seat is mounted on rails for backward or forward repositioning to accommodate the operator's size and comfort. A spring-loaded latch handle activates the seat adjustment mechanism.

Suspension Seat (Optional): A 3-position back-angle adjustment bar and a weight adjustment knob are provided with this seat for operator comfort.



Fig 5-6: Parking Brake Switch

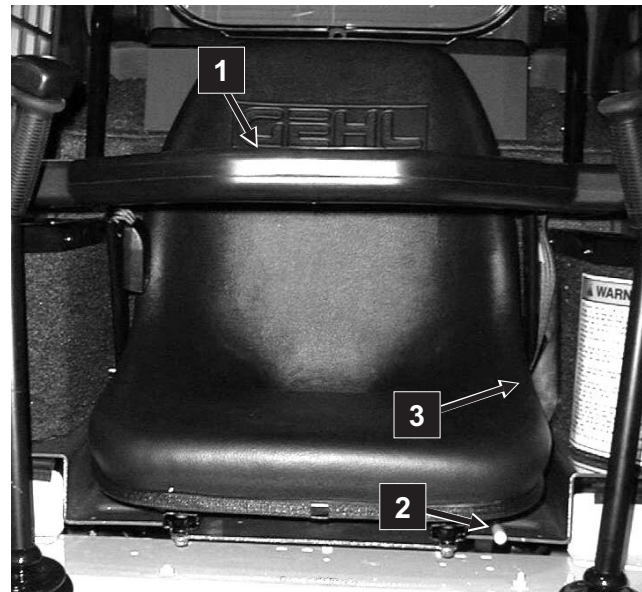

Fig 5-7: Restraint Bar

1. Operator Restraint Bar
2. Seat Forward & Backward Adjustment Lever
3. Seat Belt

Battery Disconnect Switch (Optional) (Fig. 5-8)

On loaders equipped with a battery disconnect switch, the battery can be disconnected from the electrical system by turning the switch to the “OFF” position. The switch is found below the battery, on the left side of the loader.

ROPS/FOPS & Lock Mechanism (Fig. 5-9)

The ROPS/FOPS is designed to protect the operator from falling objects and provide protection if the loader tips or rolls over provided the operator is secured inside the ROPS by the seat belt and restraint bar.

For service, unbolt the ROPS and tilt it back slowly, moving the control handles out of the way. Two gas-charged springs help tilt it back. A self-actuating lock mechanism engages to lock the ROPS in a rolled-back position. To lower the ROPS, apply upward force on it while pulling the lock mechanism handle toward the front of the loader. Lower the ROPS slowly onto the chassis, moving the control handles out of the way. Reinstall the anchor bolts, washers and locknuts.

WARNING

NEVER operate the loader with the ROPS removed or locked back. **BE SURE** the lock mechanism pin is securely engaged with the ROPS tilted back. Properly support the ROPS while unlatching the lock mechanism handle and lowering the ROPS. **BE SURE** to reinstall front anchor bolts, washers and locknuts **BEFORE** resuming loader operation.

Rear Window Emergency Exit (Fig. 5-10)

The ROPS rear window has three functions: noise reduction, falling objects barrier and emergency exit.

To use the emergency exit, pull on the yellow warning tag at the top of the window behind the seat and remove the seal. Push or kick the window out and exit.

See your local automotive glass specialist to replace the window.

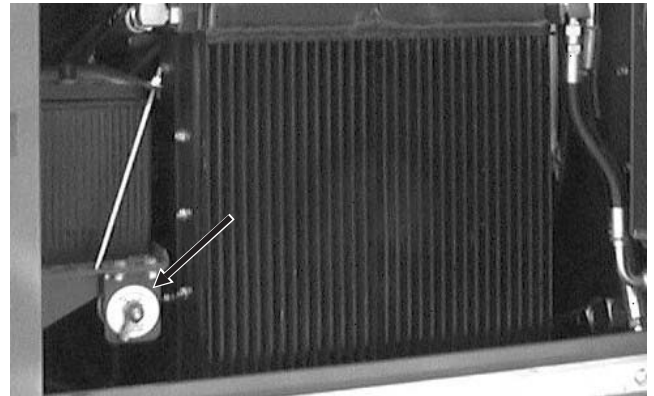

Fig. 5-8: Battery Disconnect Switch Location

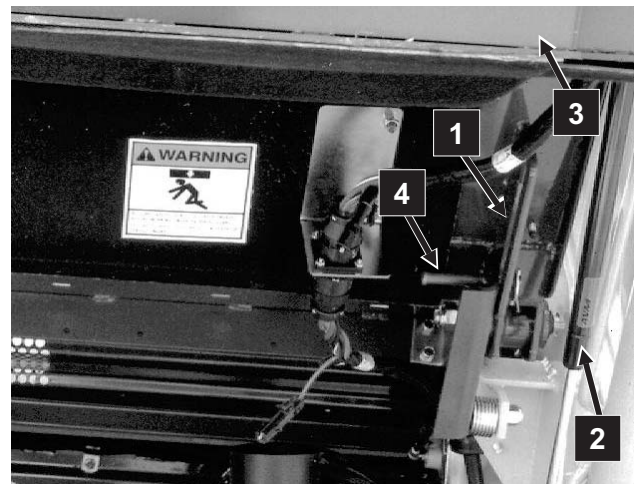

Fig. 5-9: ROPS Unbolted, Rolled-back & Locked

1. Self-actuating Lock Mechanism (Engaged)
2. Gas-charged Spring (1 of 2)
3. Roll-Over Protective Structure (ROPS)
4. Lock Mechanism Handle

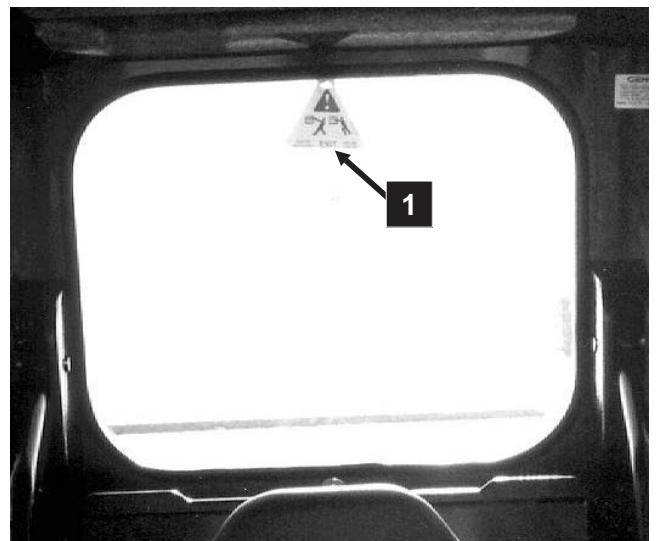

Fig. 5-10: Rear Window Emergency Exit

1. Emergency Exit Pull Tag

Instrument & Control Panel (Fig. 5-11)

The instrument and control panel contains the following control switches and indicators. International symbols on the panel represent various functions, conditions and switch positions. Symbols are visible only when indicator lamps are on.

1. **Engine Oil Temperature Gauge** - Indicates the engine oil temperature.
2. **Fuel Level Gauge** - Indicates the amount of fuel remaining in the fuel tank.

NOTE: Reference items 3 through 8 are indicator lights which display the following:

3. **Glow Plug Indicator Lamp** - After the glow plugs have heated, the lamp goes out and the engine can be started.

NOTE: Loader engine cannot be started until the operator sits on the seat and the operator restraint bar is lowered.

4. **Battery** - Indicates the condition of the charging system. During normal operation, this indicator should be OFF. If the charging voltage is too high or too low, this indicator lights.
5. **Engine Oil Pressure** - During normal operation, this indicator should be OFF. This indicator lights if the engine oil pressure drops too low, warning the operator to IMMEDIATELY stop the engine and determine the cause for the pressure drop.
6. **Fasten Seat Belt** - Audible and visual indicators remind the operator to fasten the seat belt.
7. **Engine Temperature** - During normal operation, this indicator should be OFF. This indicator lights if the engine oil gets too hot, warning the operator to IMMEDIATELY stop the engine. Allow the engine to cool, determine the cause for the high temperature condition and correct the problem BEFORE restarting the engine.
8. **Hydraulic Oil Temperature** - During normal operation, this indicator should be OFF. This indicator lights if the hydraulic system oil gets too hot, warning the operator to IMMEDIATELY stop engine. Allow the hydraulic system to cool before determining the cause of the high temperature condition.

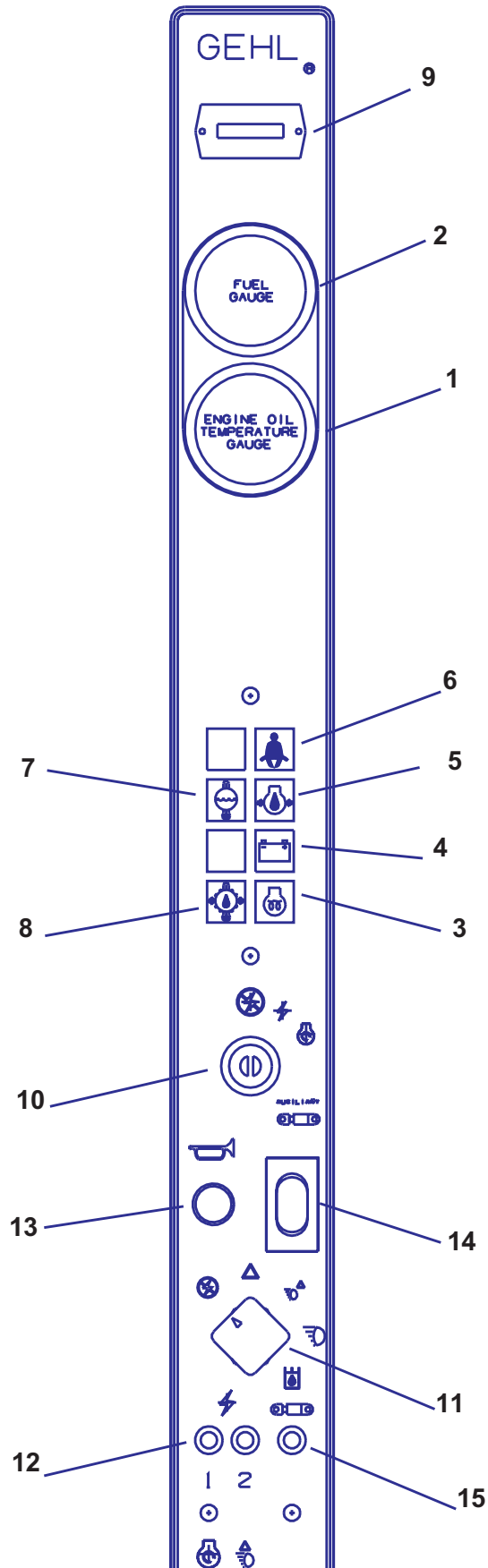

Fig. 5-11: Instrument & Control Panel

9. Hourmeter - Indicates the total operating hours of the loader. The hourmeter is especially useful for logging time in the “Maintenance Log” located in the *Maintenance* chapter of this manual.

10. Keyswitch - International symbols located around the perimeter of the keyswitch denote the key functions and positions. In a clockwise rotation, these positions are:

Off Position - With the key vertical (OFF) in the keyswitch, power from the battery is disconnected to the control and instrument panel electrical circuits. This is the only position the key can be inserted or removed from the keyswitch.

On or Run Position - With the key turned one position clockwise (RUN) from the vertical (OFF) position, power from the battery is supplied to all control and instrument panel electrical circuits.

Start Position - With the key turned fully clockwise (START) and held in position, the electric starter energizes, starting the engine. Release the key after the engine starts (it returns to the RUN position by itself).

NOTE: *The key MUST always be returned to the Off position between attempts to start the engine in order to activate the glow plug system.*

11. Light Switch - Controls all the lights (standard and optional) on the loader. International symbols denote the four positions of the light switch. In a clockwise direction these are: Off, Flashers (Hazards), Headlight/Taillight with Flashers (without rear Work Lights), and Headlight/Taillight (with rear Work Lights). For the lights to function, the keyswitch **MUST** be in the “ON” (RUN) position.

12. Circuit Breakers - Two circuit breakers on the instrument panel protect the loader electrical circuits.

IMPORTANT: *Do NOT attempt to defeat the circuit protection by jumping across the circuit breaker or by using a higher amperage circuit breaker.*

13. Horn (Optional) - A horn kit is available for installation on the skid loader.

14. Auxiliary Hydraulic Switch (Detent) (Hand & Foot Electric Auxiliary Models only) - A three-position detent switch used for continuous operation.

15. High Flow Auxiliary Hydraulic Indicator (DX Models only) - A blue lamp is used to indicate that the DX valve is engaged.

Interlock System

WARNING

NEVER defeat the interlock system by mechanically or electrically bypassing any switches, relays or solenoid valves.

An interlock system is used on the loader with operator safety in mind. Together with solenoid valves, switches and relays, the interlock:

- » Prevents the engine from starting unless the operator is sitting on the seat and the operator restraint bar is down.
- » Disables the lift arm, attachment tilt and wheel drives anytime the operator leaves the seat, turns the keyswitch to “Off” or raises the restraint bar.

Testing the Interlock System

Before leaving a parked machine, check the interlock system for proper operation:

Restraint Bar

With the engine running, raise the restraint bar.

Test each of the controls. The lift arm, attachment mechanism and machine should not move. If there is any improper movement, troubleshoot and correct the problem. Contact your Gehl dealer if necessary.

Seat Switch

With the engine off and the restraint bar lowered, unfasten your seatbelt. Lift your weight up off the seat. Try to start the engine. If the engine starts, turn off the engine, and troubleshoot and correct the problem. Contact your Gehl dealer if necessary.

Gehl All-Tach™ Attachment Mounting (Fig. 5-12)

The skid loader standard features include an All-Tach attachment mechanism for mounting a bucket or other attachment. Two latch levers secure the attachment. Rotate the levers until the handles are horizontal to engage the lock pins. Rotate the levers until the handles are vertical to disengage the lock pins.

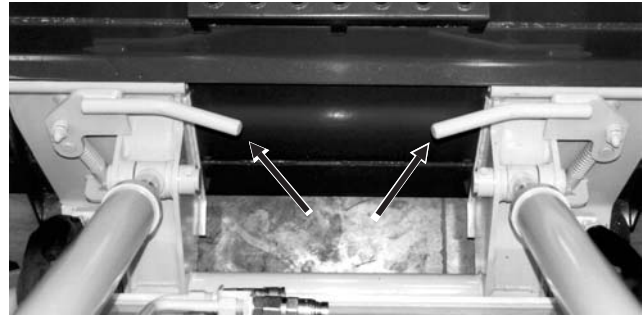

Fig. 5-12: Gehl All-Tach Attachment Levers in “Engaged” Position

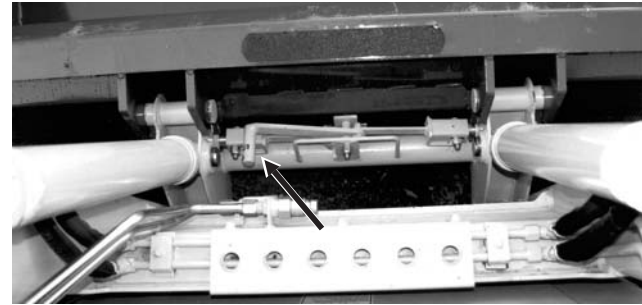

Fig. 5-13: Gehl Quick-Tach Attachment Lever in “Engaged” Position

Gehl Quick-Tach™ Attachment Mounting (Optional) (Fig. 5-13)

An optional field installed Quick-Tach attachment mechanism is available for mounting a bucket or other attachment. A single latch lever secures the attachment. Rotate the lever to the left (as viewed while sitting on the operator’s seat) to engage the lock pins. Rotate the lever to the right to disengage the lock pins.

WARNING

To prevent unexpected attachment release from the All-Tach or Quick-Tach attachment, BE SURE to secure the lock pins by rotating the All-Tach attachment levers downward into a horizontal position or the Quick-Tach attachment lever completely to the left.

Lift Arm Support Device (Figs. 5-14 & 15)

The lift arm support device found on the left lift cylinder is used as a cylinder lock to prevent the raised lift arm from unexpectedly lowering while servicing the loader. **BE SURE** to engage the support device when the lift arm is raised. When the support device is not being used, store it under the lift arm using the lock pin. The lift arm support device is a safety device that **MUST BE** kept in proper operating condition at all times. The following steps ensure correct use:

Engagement

WARNING

BEFORE leaving the operator's compartment to work on the loader with the lift arm raised, **ALWAYS** engage the lift arm support device. Turn the keyswitch off, remove the key and take it with you.

To engage the lift arm support device, proceed as follows:

1. Lower the lift arm fully onto the loader frame.
2. Turn the keyswitch to the "OFF" position to stop the engine.
3. Leave the operator's compartment. Press in and hold the lock pin button to release its locking mechanism. Remove the lock pin holding the support device up against the lift arm. Allow the support device to come down into contact with the lift cylinder.
4. Return to operator's compartment and restart the engine.
5. Use the lift control to raise the lift arm until the lift arm support device drops over the end of the lift cylinder and around the cylinder rod. Slowly lower the lift arm until the free-end of the support device contacts the top end of the lift cylinder.
6. Look to make sure the support device is secure against the cylinder end. Then, stop the loader engine, remove the key and leave the operator's compartment.



Fig. 5-14: Lift Arm Raised and Support Device Engaged

1. Lift Arm
2. Lift Arm Support Device
3. Lock Pin
4. Lift Cylinder

Disengagement

WARNING

NEVER leave the operator's compartment to disengage the lift arm support device with the engine running.

To return the lift arm support device to its storage position, proceed as follows:

1. Raise the lift arm completely.
2. Turn the keyswitch to the off position to stop the engine, remove the key and take it with you.

WARNING

Before testing the machine, ALWAYS clear people from the area.

3. Before leaving the operator's compartment, check to make sure that the lift arm is being held in the raised position by the solenoid valve (See NOTE below).

NOTE: With the keyswitch OFF and the solenoid valve working, the arm will stay raised when the lift control is moved forward. If the valve does NOT hold the arm and it begins to lower, do NOT leave the operator's compartment. Instead, have someone store the support device for you. Then, contact your Gehl dealer to determine the reason why the lift arm lowers while the keyswitch is in the OFF position.

4. To store the support device, raise it up until it contacts the lift arm. Press in and hold the lock pin button to release its locking mechanism. Insert the lock pin through the hole in lift arm and through the support device.

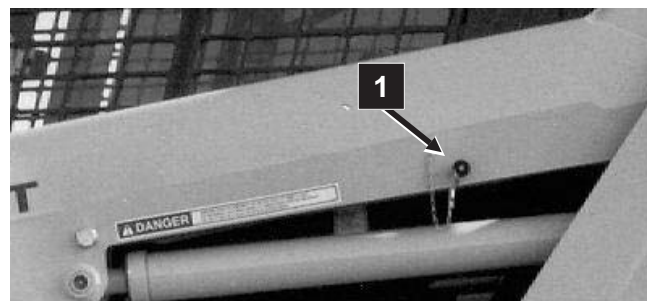

Fig. 5-15: Lift Arm Lowered and Support Device Stored

1. Lock Pin (mechanical lock hidden from view)

Auxiliary Hydraulics

Auxiliary hydraulics are used on an attachment that has a mechanism requiring hydraulic power of its own.

Standard Flow Auxiliary Hydraulics (Fig. 5-16)

Skid loaders are shipped from the factory with standard flow auxiliary hydraulics with flat face disconnect couplers. The couplers are located under the lift arm on the left hand side.

A second set of hydraulic disconnect couplers can be added to the front of the lift arm by ordering field installation kit 807233.

Standard auxiliary hydraulics can be added to an SL4635 by ordering field installation kit 807239.

T-Bar and Dual Hand controlled loaders: A foot pedal is used to control the direction of oil flow. A stop is provided to lock the foot pedal for continuous operation.

Hand & Foot controlled loaders with electric auxiliary hydraulics: A 3-position momentary switch is located on the right control handle and a 3-position detent switch for continuous operation is located on the instrument panel for operating the auxiliary hydraulics.

Hand & Foot controlled loaders with mechanical auxiliary hydraulics: The right control handle can be rotated up and down. It can be locked in the up position for continuous operation of the auxiliary hydraulics.

High Flow Auxiliary Hydraulics (Fig. 5-17 & 5-18)

In addition to standard flow auxiliary hydraulic connections, DX model loaders are shipped from the factory with reversible high flow auxiliary hydraulics. These additional quick-disconnect fittings are located under the right lift arm. They are used for operating high oil flow hydraulic attachments (cold planer, snowblower, etc.).

A 3-position control lever is located to the right of the right control lever. The lever is spring centered with a detent in the forward position for continuous operation. A blue light on the instrument panel indicates that the high flow is engaged.

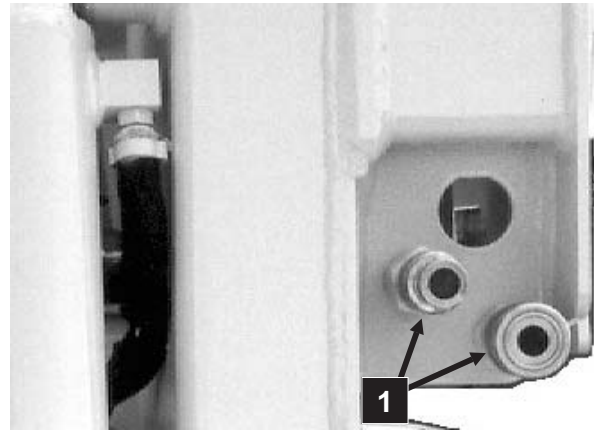

Fig. 5-16: Standard Flow Auxiliary Hydraulics

1. Standard Flow Quick-Disconnects

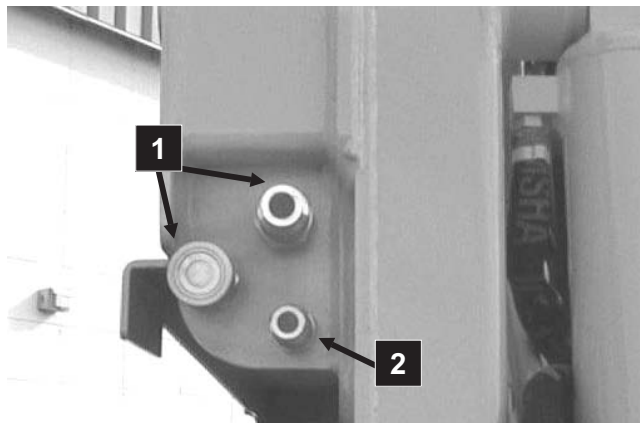

Fig. 5-17: High Flow Auxiliary Hydraulics

1. High Flow Quick-Disconnects
2. Case Drain Line



Fig. 5-18: High Flow Control Lever

CHAPTER 6

OPERATION

General Information (Fig. 6-1)

CAUTION

BEFORE starting the engine and operating the loader, review and comply with **ALL** safety recommendations in the **SAFETY** chapter of this manual. Know how to **STOP** the loader **BEFORE** starting it. Also, **BE SURE** to fasten and properly adjust the seat belt and lower the operator restraint bar.

Before Starting Engine

Before starting the engine and running the loader, refer to the *Controls & Safety Equipment* chapter and familiarize yourself with the various operating controls, indicators and safety devices on the loader.

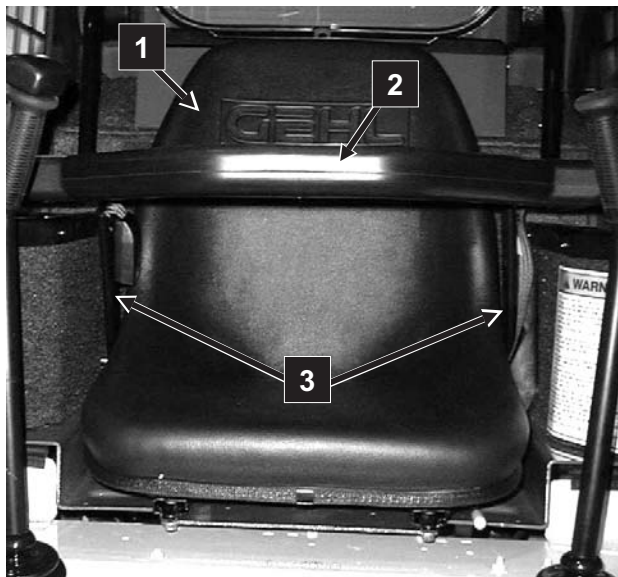

Fig. 6-1: Operator's Compartment

1. Operator's Seat
2. Operator Restraint Bar in "Lowered" Position
3. Seat Belt

Starting The Loader

WARNING

ALWAYS fasten your seat belt and lower the restraint bar **BEFORE** starting the engine.

The following procedure is recommended for starting the loader engine:

1. Carefully step up onto the back of the bucket or attachment while grasping the ROPS handles to get into the operator's compartment.
2. Fasten the seat belt and lower the restraint bar.
3. Verify the following:
 - the lift/tilt and drive control handles are in their neutral positions
 - the auxiliary control is in neutral
 - the brake is on
 - the high flow control lever (DX models only) is in neutral
4. Push the throttle forward to half of full speed.

NOTE: When the key is turned to the "ON" position, a buzzer will sound momentarily reminding you to check that your seat belt is fastened.

5. Turn the keyswitch to the "ON" position. Wait for the glow indicator light to go out, then turn the key to the start position. (Glow is automatically controlled and is used only if temperature is 32°F (0°C) or below).

NOTE: Crank the starter until the engine is started. If the engine fails to start within 15 seconds, return the key to the "Off" position and repeat Step 5. Cranking the engine for longer than 15 seconds will result in premature failure of the starter.

After the engine starts, allow a sufficient warm-up time before attempting to operate the controls.

Cold Starting Procedure

The following procedure should be used when starting a skid loader in cold temperatures: Turn the key to the RUN position. If the glow light comes on the instrument panel, wait until it goes out before turning the key to the START position.

A pan heater is recommended for starting in temperatures of 20°F (-7°C) or lower. See your Gehl dealer for recommended heater options.

Loader Movement

The hydrostatic drive of the skid loader controls forward and reverse directions and speed. Movement of the wheels is slowed according to how rapidly the drive control handle(s) are moved to the straight “neutral” position.



Operate the drive control handles gradually and smoothly when starting, stopping, turning and reversing loader directions. Excessive speed can be hazardous. ALWAYS exercise caution and good judgment while operating the skid loader.

Stopping the Loader

The following procedure is the recommended sequence for stopping the loader:

1. Check that drive control handles are in the “neutral” position.
2. Lower the lift arm and rest the attachment on the ground.
3. Pull the throttle lever back to the idle position (*and/or take your foot off the accelerator pedal for hands only controlled machines*).
4. Turn the keyswitch key to the off position to shut the engine off.
5. Raise the restraint bar, unlatch the seat belt and grasp the handles while climbing out of the operator’s compartment.

NOTE: *The skid loader is equipped with a spring-applied automatic parking brake. The parking brake is engaged when the operator lifts the restraint bar, leaves the operator’s seat, shuts the engine off or when the manual switch is on (the top half of the switch is pushed in).*

IMPORTANT: *High heat and excessive loads may cause the engine to overheat. See the Troubleshooting chapter in this manual for further instruction.*

First Time Operation



BE SURE the area used for test-running is clear of spectators and obstructions. For the first time, operate the loader with an empty bucket.

The smoothest and most efficient loader operation is achieved running the engine at half-throttle. Make sure the engine is warm and follow the instructions appropriate for your type of loader as detailed in the *Controls & Safety Equipment* chapter.

Perform all raising and lowering functions, and combinations of the two functions before operating the drive controls. ALWAYS lower the lift arm and roll the bucket back BEFORE proceeding to operate the drive controls. Return the controls to the “neutral” position to stop all lift/tilt functions.

Perform all drive control functions before operating **both** lift/tilt and drive controls. Return the drive controls to the “neutral” position to stop all movement.

NOTE: *If the engine stalls, all controls must be returned to their “neutral” positions before restarting the engine.*

Operating skills are obtained through proper coordination of the loader’s forward and reverse movements, with raising and lowering the lift arm and rolling the bucket forward and back. To gain proficiency, practice all control handle operations until you are capable of performing the movements without mistake or hesitation.

WARNING

BEFORE leaving the operator’s compartment, **BE SURE** to lower the lift arm or engage the lift arm support device, as appropriate.

NOTE: *If the loader will not start, the lift arm can be lowered by sitting in the operator’s seat with the restraint bar down, turning the key to the “ON” position and then lowering the lift arm.*

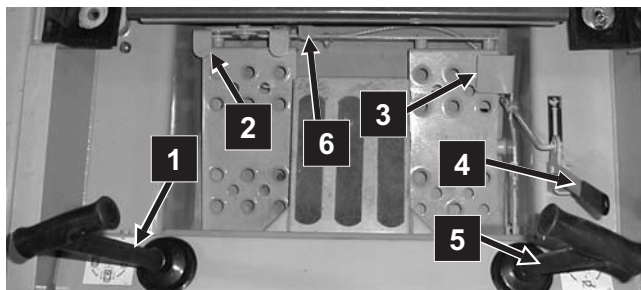

Fig. 6-2: T-Bar Controls

1. Drive Control T-Bar
2. Auxiliary Hydraulics Foot Pedal
3. Foot Throttle
4. Hand Throttle
5. Lift/Tilt Control T-Bar
6. Auxiliary Hydraulics Foot Pedal Stop

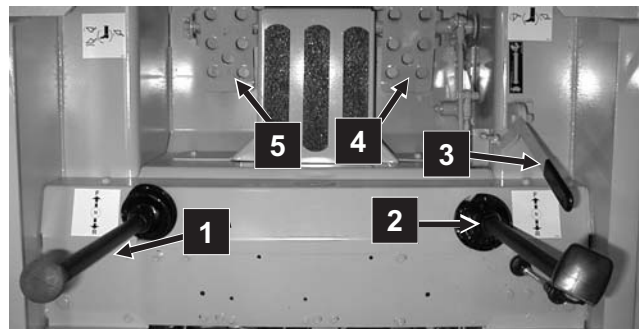

Fig. 6-3: Hand & Foot Controls w/Electric Auxiliary Hydraulics

1. Left Drive Control Handle
2. Right Drive Control Handle & Electric Auxiliary Hydraulic Switch
3. Hand Throttle
4. Tilt Control Foot Pedal
5. Lift Control Foot Pedal

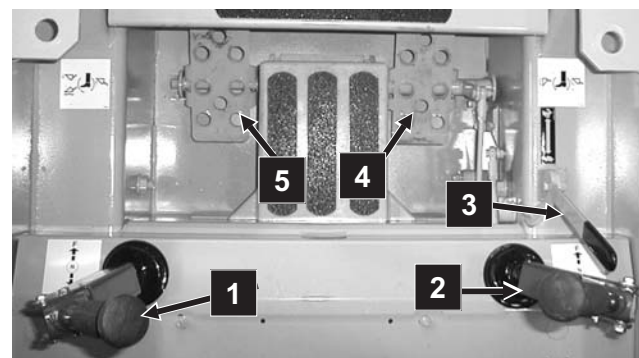

Fig 6-4: Hand & Foot Controls w/Mechanical Auxiliary Hydraulics

1. Left Drive Control Handle
2. Right Drive Control Handle & Mechanical Auxiliary Hydraulic Control
3. Hand Throttle
4. Tilt Control Foot Pedal
5. Lift Control Foot Pedal

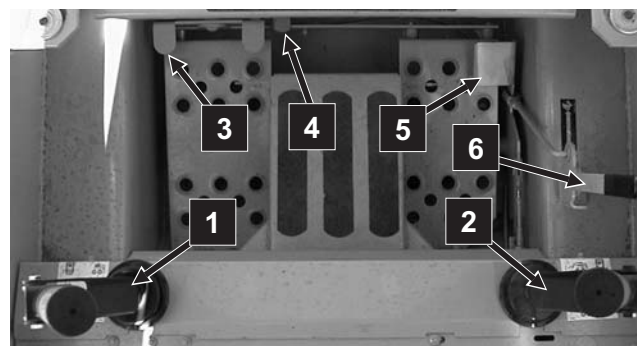

Fig. 6-5: Dual Hand Controls

1. Left Drive/Lift Control Handle
2. Right Drive/Tilt Control Handle
3. Auxiliary Hydraulics Foot Pedal
4. Auxiliary Hydraulics Foot Pedal Stop
5. Foot Throttle
6. Hand Throttle

Changing Attachments

Gehl All-Tach™ Attachment Mounting (Fig. 6-6)

WARNING

To prevent unexpected attachment release from the All-Tach attachment, **BE SURE** to properly secure the All-Tach mechanism lock pins by rotating the latch levers to a horizontal position.

The skid loader features an All-Tach attachment mechanism for mounting a bucket or other attachment. Two latch levers secure the attachment.

Attaching

1. Rotate the latch levers to a vertical position to fully retract the latch pins.
2. Start the loader engine and make sure the lift arm is lowered and in contact with the loader frame.
3. Align the loader squarely with the back of the attachment.
4. Roll the All-Tach attachment mechanism forward until the top edge of the All-Tach mechanism is below the flange on the back side of the attachment and centered between the vertical plates.
5. Slowly drive the loader forward and, at the same time, roll the All-Tach attachment mechanism back to engage the flange on the back side of the attachment.
6. Stop forward travel when the flange is engaged but, continue to roll the All-Tach attachment mechanism back to pick the attachment up off the ground. Exercise the **MANDATORY SAFETY SHUTDOWN PROCEDURE (page 10)**.
7. With the loader engine OFF, leave the operator's compartment and swing the latch levers to a horizontal position to fully engage the latch pins.
8. To check that the attachment is properly installed, apply down pressure to the attachment prior to operating.

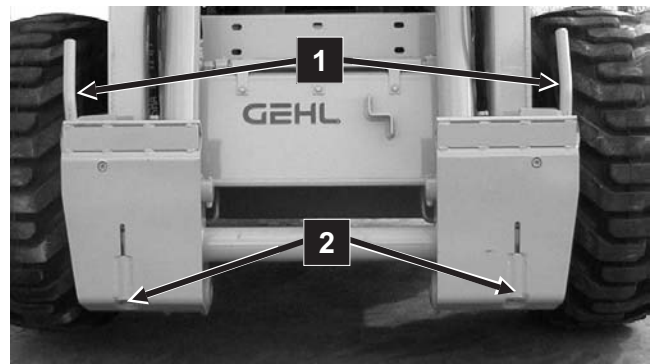

Fig. 6-6: All-Tach Attachment (Disengaged)

1. All-Tach Attachment Latch Control Levers
2. All-Tach Attachment Latch Pins

Detaching

1. Roll the All-Tach attachment mechanism backward until the attachment is off the ground. Exercise the **MANDATORY SAFETY SHUTDOWN PROCEDURE (page 10)**.
2. With the loader engine OFF, leave the operator's compartment and rotate the latch levers completely vertical to fully retract the latch pins.
3. Start the loader engine and make sure that the lift arm is lowered and in contact with the loader frame.
4. Roll the All-Tach attachment mechanism forward and slowly back the loader until the attachment is free from the loader.

Gehl Quick-Tach™ Attachment Mounting (Optional) (Fig. 6-7)

WARNING

To prevent unexpected attachment release from the Quick-Tach attachment, **BE SURE** to properly secure the Quick-Tach mechanism lock pins by rotating the latch lever all the way to the left.

A field installed Quick-Tach attachment mechanism for mounting a bucket or other attachment is available. A single latch lever secures the attachment.

Attaching

1. Rotate the latch lever completely to the right (as viewed from the operator's compartment) to fully retract the latch pins.
2. Start the loader engine and make sure the lift arm is lowered and in contact with the loader frame.
3. Align the loader squarely with the back of the attachment.
4. Roll the Quick-Tach mechanism forward until the mating parts of the mechanism are in-line with and slightly below the hooks on the back of the attachment.
5. Slowly drive the loader forward and, at the same time, roll the Quick-Tach mechanism back to engage the hooks on the attachment.
6. Stop forward travel when the hooks are engaged but continue to roll the Quick-Tach mechanism back to pick the attachment up off the ground. Exercise the **MANDATORY SAFETY SHUTDOWN PROCEDURE** (page 10).
7. With the loader engine OFF, leave the operator's compartment, and swing the latch lever completely to the left (as viewed from the operator's compartment) to fully engage the latch pins.
8. To check that the attachment is properly installed, apply down pressure to the attachment prior to operating.

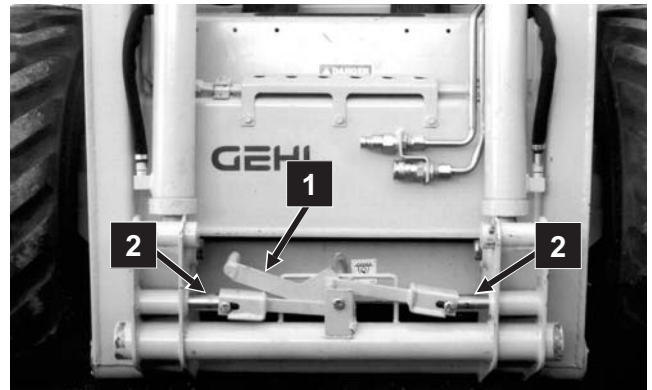

Fig. 6-7: Quick-Tach Attachment (Disengaged)

1. Quick-Tach Attachment Latch Lever
2. Quick-Tach Attachment Latch Pins

Detaching

1. Roll the Quick-Tach mechanism backward until the attachment is off the ground. Exercise the **MANDATORY SAFETY SHUTDOWN PROCEDURE** (page 10).
2. With the loader engine OFF, leave the operator's compartment and rotate the latch lever completely to the right (as viewed from the operator's compartment) to fully retract the latch pins.
3. Start the loader engine and make sure that the lift arm is lowered and in contact with the loader frame.
4. Roll the Quick-Tach mechanism forward and slowly back the loader until the attachment is free from the loader.

Self-Leveling

Skid loaders are provided with a hydraulic self-leveling feature. This feature is designed to keep the attachment level while the lift arm is being raised.

Material Densities

The table at the right lists densities for some common materials which could be carried in a bucket. The densities listed are average values and intended only as a guide for bucket selection. For a material that is not in the table, obtain its density value before selecting the appropriate bucket.

To prevent exceeding the operating load of the loader, use the Table of Common Materials and Densities to determine the proper size bucket to use based on the type of material to be carried.

SAE Rated Operating Load

Model	lbs	kg
SL4635	1425	646
SL4835	1625	737

To use the table, find the material name and see what its maximum density is. Then, divide the operating load of the loader by the material density to determine the **maximum** size bucket to use for a heaped load.

NOTE: Where the material density is listed as a range (clay at 80-100 lb/ft³, for example), always use the maximum density (100 lb/ft³ in this example) for making calculations. Also, see the following examples.

Example 1: If clay (density of 80-100 lb/ft³) is to be hauled using an **SL4635** loader, the maximum bucket size is (**1425 lb** \div **100 lb/ft³** = **14.2 ft³**). Therefore, you could safely use a bucket that has a capacity of **14.2 cubic feet or less**.

Example 2: If concrete (density of 1840 kg/m³) is to be hauled using an **SL4835** loader, the maximum bucket size is (**737 kg** \div **1840 kg/m³** = **0.40 m³**). Therefore, you could safely use a bucket that has a capacity of **0.40 cubic meters or less**.



NEVER exceed the rated operating load of the loader as shown on the capacity decal.

Table of Common Materials and Densities

Material	Density	
	(lb/ft ³)	(kg/m ³)
Ashes	35-50	560-800
Brick-common	112	1792
Cement	110	1760
Charcoal	23	368
Clay	80-100	1280-1600
Coal	53-63	848-1008
Concrete	115	1840
Cinders	50	800
Coal-anthracite	94	1504
Coke	30	480
Earth-dry loam	30	480
Earth-wet loam	65	1040
Granite	93-111	1488-1776
Gravel-dry	66	1056
Gravel-wet	90	1440
Gypsum-crushed	115	1840
Iron Ore	145	2320
Lime	60	960
Lime Stone	90	1440
Manure-liquid	65	1040
Manure-solid	45	720
Peat-solid	47	752
Phosphate-granular	90	1440
Potash	68	1088
Quartz-granular	110	1760
Salt-dry	100	1600
Salt-Rock-solid	135	2160
Sand-dry	108	1728
Sand-wet	125	2000
Sand-foundry	95	1520
Shale-crushed	90	1440
Slag-crushed	70	1120
Snow	15-50	240-800
Taconite	107	1712

The *Specifications* chapter lists the buckets available and their capacities to help you decide what size bucket to use. You may always use a smaller-capacity bucket, but NOT a bucket with greater capacity than the calculated MAXIMUM unless it is only partially filled.

Loader Operations
(Figs. 6-8 to 6-14)

! WARNING

ALWAYS maintain a safe distance from electric power lines and avoid contact with any electrically charged conductor or gas line! Accidental contact or rupture can result in electrocution or an explosion! Contact the North American One Call Referral System at (888) 258-0808 for the local "Digger's Hotline" number or the proper local authorities for utility line locations **BEFORE** starting to dig!"

Digging with and Loading a Bucket

To dig with and load a bucket, first lower the lift arm down into contact with the loader frame and then roll the bucket's cutting edge down into contact with the ground. Move the loader into material and, as the engine loads, roll the bucket back slowly and, at same time, gradually pull back the drive control handle(s) to decrease the travel speed while still maintaining wheel torque.

When filling the bucket with hard-packed materials, it may be necessary to raise the lift arm while rolling the bucket back. Avoid driving onto the material to be picked-up, if at all possible.

! WARNING

ALWAYS carry the loaded bucket with the lift arm resting on the loader frame. For additional stability when operating on inclines, **ALWAYS** travel with the heavier end of the loader toward the top of the incline.

With the bucket filled, back the loader away from the material and rest the lift arm against the loader frame before proceeding to the dumping area.

Dumping the Load Onto a Pile

Carry a loaded bucket as low as possible until reaching the pile. Slowly stop forward motion and raise the lift arm high enough so that the bucket clears the top of the pile. Then, slowly move the loader ahead to position the bucket to dump the material on top of the pile. Empty the bucket and back the loader away while lowering the lift arm and rolling the bucket back.

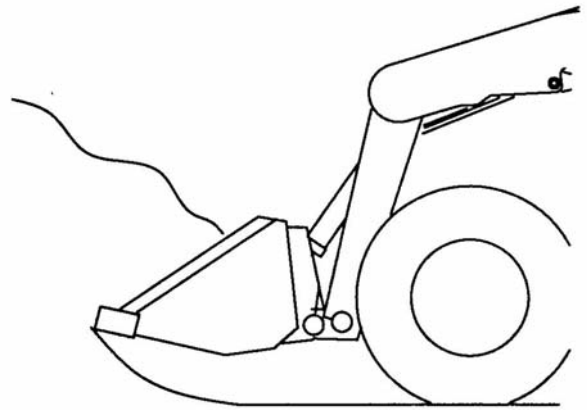

Fig. 6-8: Loading the Bucket

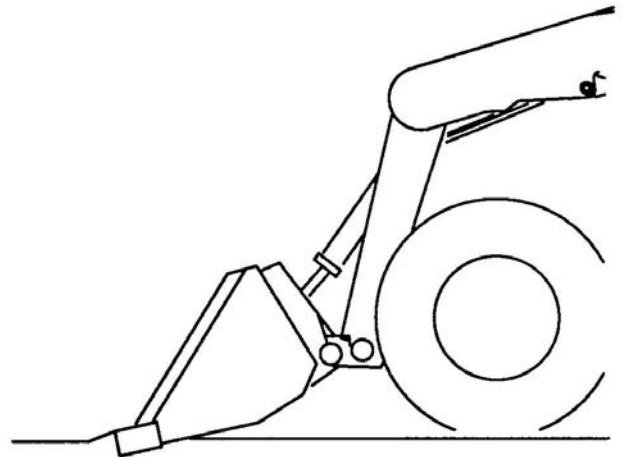

Fig. 6-9: Digging in Hard-packed Materials

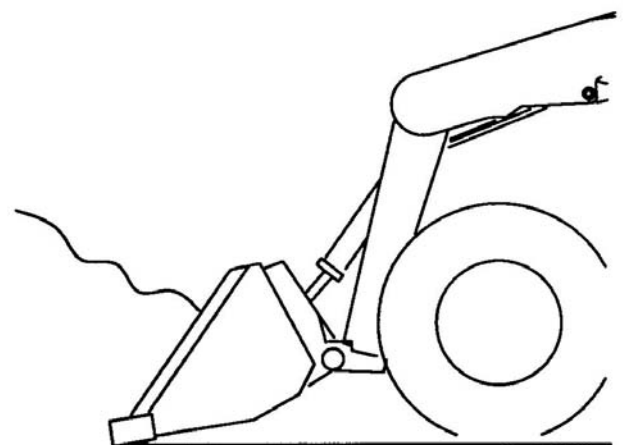

Fig. 6-10: Digging in Loose Materials

WARNING

NEVER push the controls into the “float” position with the bucket or attachment loaded or raised, because it will cause the lift arm to lower rapidly.

Dumping the Load Into a Box

Carry the loaded bucket low and approach the truck, trailer or spreader box squarely with the side of the box. Stop your approach as close to the side of the box as possible while allowing for clearance to raise the lift arm and loaded bucket. Next, raise the lift arm until the bucket clears the top of the box and move the loader ahead to position the bucket over the inside of the box. After the material is dumped, back away from the box and lower the lift arm while rolling the bucket back.

Dumping the Load Over A Solid Embankment

WARNING

Do **NOT** drive too close to an excavation or ditch; **BE SURE** the surrounding ground has adequate strength to support the weight of the loader and the load.

Carry the loaded bucket as low as possible while traveling to the dumping area. Stop the loader where the bucket extends half-way over the edge of the embankment. Roll the bucket forward and raise the lift arm to dump the material. After the material is dumped, back away from the embankment while lowering the lift arm and rolling the bucket back.

Scraping with a Bucket

For scraping, the loader should be operated in the forward direction. Position the lift arm down against the loader frame. Tip the bucket cutting edge at a slight angle to the surface being scraped. While traveling slowly forward with the bucket in this position, material can flow over the cutting edge and collect inside the bucket.

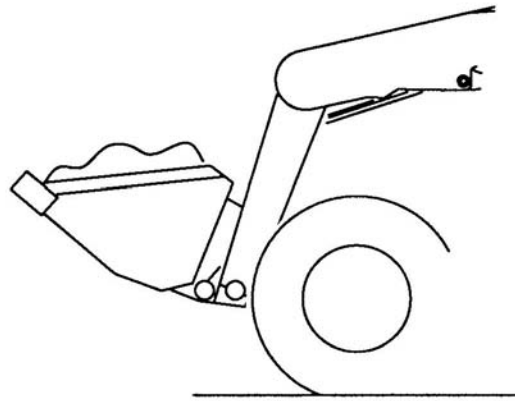

Fig. 6-11: Carrying the Load

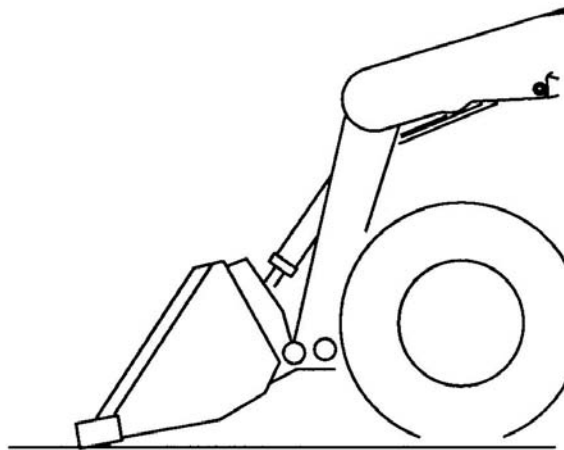

Fig. 6-12: Positioning a Bucket for Scraping

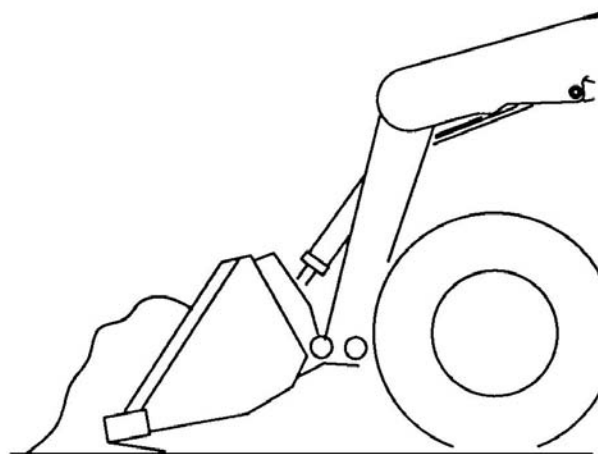

Fig. 6-13: Scraping with a Bucket

Leveling with a Bucket

Drive the loader to the outer edge of the area to be leveled. Then, with the lift arm down against the frame, push the lift/tilt handle (*hand controlled loaders*), or left foot pedal (*hand & foot controlled loaders*), into the “float” position and roll the bucket forward to place the bucket cutting edge at a 30 to 45 degree angle to the surface being leveled. Drive the loader backwards dragging the dirt and, at the same time, leveling it.

NOTE: The “float” (detent) position for T-bar controlled loaders is reached by pushing the right handle all the way forward. For hand & foot controlled loaders use your toe to push the front of the left foot pedal all the way down. For dual hand controlled loaders push the left handle all the way down. This position opens both work ports to the reservoir and thus allows the lift arm to “float” while the bucket follows the ground contour.

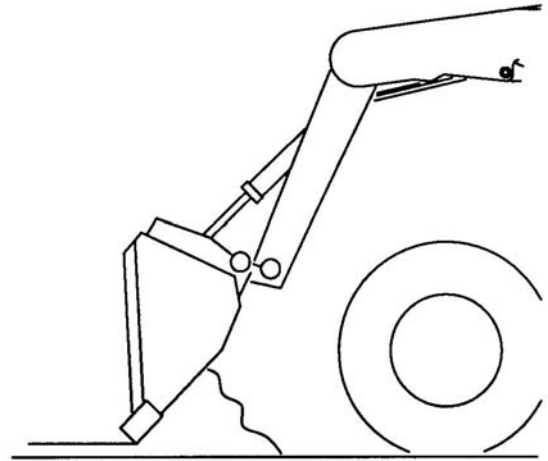

Fig. 6-14: Leveling with a Bucket

Highway Travel

When it becomes necessary to frequently move the loader over long distances, obtain and use a properly rated loader trailer. For short distance highway travel, attach a SMV (Slow Moving Vehicle) emblem (purchased locally) to the back of the loader. For highway operation, obtain and install amber dual flashers or a strobe light. Check state and local laws and regulations.

Long Term Storage

If your skid loader is to be stored for a long period of time, the following procedure is suggested:

1. Fully inflate the tires.
2. Lubricate all grease zerks.
3. Check all fluid levels and replenish as necessary.
4. Add stabilizer to the fuel per the fuel supplier's recommendations.
5. Remove the battery, charge fully and store in a cool, dry location.
6. Protect against extreme weather conditions such as moisture, sunlight and temperature.

Transporting the Loader

WARNING

Park the truck or trailer on a level surface. Be sure that the vehicle and its ramps have the weight capacity to support the loader. Be sure the vehicle surface and its ramps are free of debris and slippery material that may reduce traction. Move the loader on and off the vehicle ramp slowly and carefully. Failure to follow these instructions could result in an overturn accident.

Observe all local regulations governing the loading and transporting of equipment. Ensure that the hauling vehicle meets all safety requirements before loading the skid loader.

1. Place a block at the front and rear of the hauling vehicle's tires.
2. If the loader has an attachment, lift it slightly off the ground.



Fig. 6-15: Rear Tie-Down Locations



Fig. 6-16: Front Tie-Down Locations

3. Back the loader slowly and carefully up the ramp onto the vehicle.
4. Lower the loader attachment to the vehicle deck, turn off the engine and remove the key.
5. Fasten the loader to the hauling vehicle at the points indicated by the tie-down decals (figs. 6-15 & 16).
6. Measure the clearance height of the loader and hauling vehicle. Post the clearance height in the cab of the vehicle.

Lifting the Loader

The skid loader can be lifted with a four point lift kit that can be purchased from your local Gehl dealer. Follow the instructions supplied with the kit.

CHAPTER 7

ADJUSTMENTS

Loader Raising Procedure

To raise the skid loader so all four (4) tires ARE NOT contacting the ground, use the procedure below:

WARNING

BEFORE servicing the machine, exercise the MANDATORY SAFETY SHUTDOWN PROCEDURE (page 10).

WARNING

DO NOT rely on a jack or hoist to maintain the “raised” position without additional blocking and supports. Serious personal injury could result from improperly raising or blocking the skid loader.

1. To block the loader, obtain enough solid wooden blocks, so that when stacked, all of the tires are raised off the ground.
2. Using a jack or hoist capable of lifting at the fully-equipped weight of the loader (with all attached options), lift the rear of the loader until the rear tires are off the ground.
3. Stack wooden blocks under the flat part of the loader chassis. They should run parallel with, but not touch, the rear tires (fig. 7-1).
4. Slowly lower the loader until its weight rests on the blocks. If the tires still touch the ground, raise the loader again, add more blocks and lower again.
5. Repeat Steps 2 through 4 for the front end. When the procedure is finished, all four tires are off the ground so they could be removed.

Loader Lowering Procedure

When service or adjustment procedures are complete, the skid loader can be taken down from the “raised” position. To lower the loader onto its tires:

1. Using a jack or hoist, raise the front of the loader until its weight no longer rests on the front blocks.
2. Carefully remove the blocking under the front of the loader.
3. Slowly lower the loader until the front tires are resting on the ground.
4. Repeat Steps 1 through 3 for the rear of the loader. When the procedure is finished, all four (4) tires should be on the ground and the blocking should be removed from under the loader.

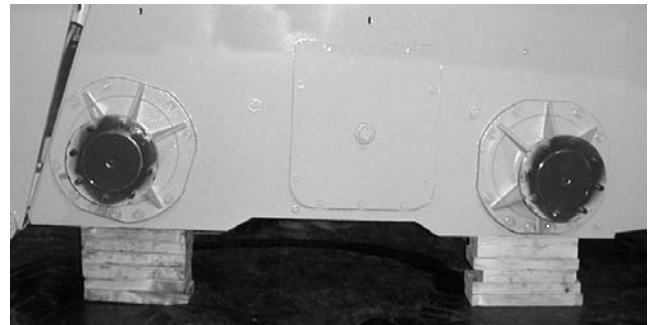

Fig. 7-1: Skid Loader Properly Blocked
(Tires and wheels are removed to show blocks)



WARNING

BEFORE servicing the machine, exercise the MANDATORY SAFETY SHUTDOWN PROCEDURE (page 10).

Engine

Skid loaders are provided with separate engine maintenance manuals which should be consulted for engine related specifications, adjustments, maintenance and service information.

Control Handles

Both control handles are factory adjusted and should require NO further readjustment. If the drive control handles are removed for service, refer to the Shop Manual or your Gehl dealer for proper settings and adjustment details.

Fuel Sender

The fuel sender, located in the left riser, sends a signal to the fuel gauge indicating the amount of fuel left in the fuel tank.

Check the fuel sender periodically to ensure that the mounting screws are set and that there is no fuel seepage around the gasket. If adjustment is required, apply a gasket sealant around the gasket when restoring the fuel sender.

Throttle Lever and Accelerator Pedal

The skid loader is equipped with a right hand-operated throttle lever.

T-Bar and Dual Hand controlled loaders are also equipped with a right foot-operated accelerator pedal.

The linkage used to connect the accelerator pedal to the throttle lever has an adjustable yoke to alter the amount of travel required to go from idle to full speed. The throttle cable is factory adjusted and should require NO further readjustment. If the cable is removed for service, refer to the Shop Manual or your Gehl dealer for proper adjustment details.

Besides throttle cable adjustment, the throttle lever friction pad pressure can be readjusted if the throttle lever does NOT hold its position. Belleville washers and a lock nut are used for making this adjustment.

Drive Chains (Fig. 7-2)

Drive chains should be checked every 100 hours of operation, and adjusted as necessary. To properly check and adjust the drive chain tension, follow the directions in this section.

To check chain tension without removing the access covers:

1. Raise the loader off the ground following the "Loader Raising Procedure" topic at the beginning of this chapter.
2. Rotate each tire by hand. The proper amount of rotation should be 1/8" - 1" (3-25 mm) forward & back. If the rotation is more than 1" (25 mm), or less than 1/8" (3 mm) in either direction, the access covers should be removed and the chains adjusted.

To Adjust Chain Tension

1. Raise the loader off the ground following the "Loader Raising Procedure" topic at the beginning of this chapter.
 2. Remove the access cover located between the wheels to gain access to the drive chain front and rear take-up assemblies.
 3. Rotate the front and rear tires (by hand) towards each other so the slack sides of the chains are at the top.
 4. Working through the access hole, loosen the lock nut then the flanged lock nut on either of the two chains.
 5. Begin tightening the adjustment nut. This will cause the idler assembly to lower, thereby increasing tension on the chain.
 6. The correct chain deflection is 1/2" (12 mm) minimum on the side opposite from the adjuster - halfway between the sprockets (fig. 7-2).
 7. After the proper chain tension is obtained, retighten the flanged lock nut and lock nut.
- IMPORTANT:** *Over-tightening the drive chain will cause premature drive chain and axle sprocket wear.*
8. Repeat steps 4 through 7 for the other chain.
 9. Reinstall the chaincase access covers using oil resistant RTV or equivalent between the cover and the chaincase. If necessary, replenish the chaincase oil level until oil runs out of the oil level check plug (fig. 7-2).
 10. Repeat steps 2 through 9 for the other side of loader.
 11. Follow the "Loader Lowering Procedure" topic at the beginning of this chapter to return the loader to the ground.

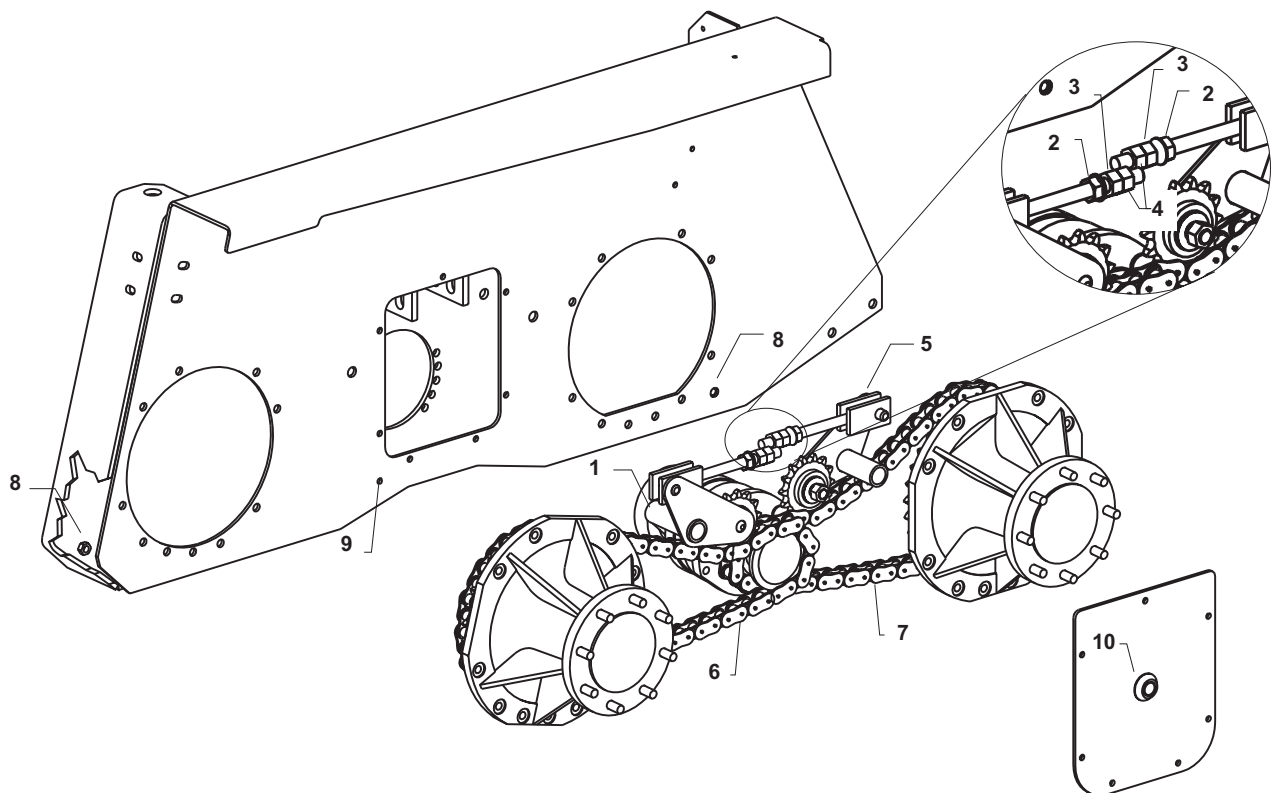

Fig. 7-2: Adjusting Drive Chain Tension - Left side shown, right side typical

- | | |
|--------------------------|-------------------------|
| 1. Front Adjuster | 6. Front Chain Drive |
| 2. 3/4" Flanged Lock Nut | 7. Rear Drive Chain |
| 3. 3/4" Adjustment Nut | 8. Drain Plugs |
| 4. Lock Nut | 9. Oil Level Check Plug |
| 5. Rear Adjuster | 10. Oil Fill Plug |

Electric Auxiliary Controls Adjustment (Fig. 7-3)

If your loader is hand & foot operated, it may be equipped with electrically controlled auxiliary hydraulics. Follow the procedure below for adjustment of those controls.

1. With the panel switch down, adjust potentiometer #2 clockwise until a squealing or ticking in the actuator is heard or felt. Turn counterclockwise slightly to obtain full retraction without squealing or ticking. Continue turning counterclockwise another 1/8 of a turn.
2. With the panel switch down and the handle switch to the left, adjust potentiometer #4 counterclockwise

until a squealing or ticking is heard or felt. Turn clockwise slightly to obtain full extension without squealing or ticking. Continue turning clockwise another 1/8 of a turn.

3. With the panel switch up, adjust potentiometer #1 counterclockwise until a squealing or ticking is heard or felt. Turn clockwise slightly to obtain full extension without squealing or ticking. Continue turning clockwise another 1/8 of a turn.
4. With the handle switch to the left, adjust potentiometer #3 clockwise until a squealing or ticking is heard or felt. Turn counterclockwise slightly to obtain full retraction without squealing or ticking. Continue turning counterclockwise another 1/8 of a turn.

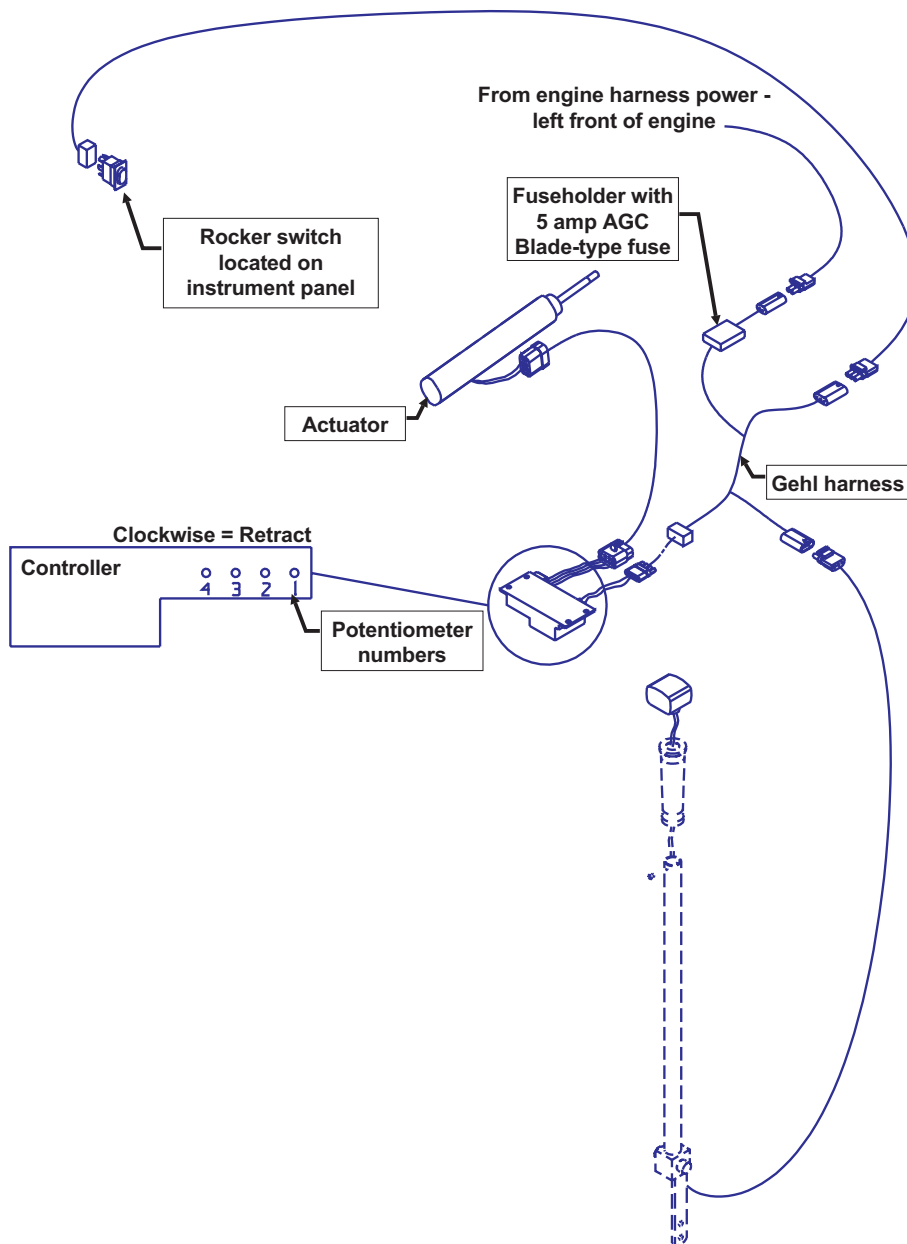

Fig. 7-3: Electric Auxiliary Controls Adjustment

CHAPTER 8

LUBRICATION

General Information

WARNING

NEVER service this unit when any part of the machine is in motion. **ALWAYS BE SURE** to exercise the **MANDATORY SAFETY SHUTDOWN PROCEDURE** (page 10) **BEFORE** servicing this equipment.

NOTE: The Maintenance chapter in this manual has tables for recording the dates and hour meter readings after lubrication or other service has been performed; use the tables to keep a log for maintaining a current service interval record. Proper routine lubrication is an important factor in preventing excessive part wear and early failure.

WARNING

Allow hot surfaces to cool before performing any lubrication.

Lubricants

NOTE: All lubrication should be performed on a stable, level surface.

The chart below lists the locations, temperature ranges and types of recommended lubricants to be used when servicing this machine. Refer to the separate engine manual for more information regarding recommended engine lubricants, quantities required and grades.

IMPORTANT: Avoid mixing lubricants. If a container other than the lubricants original container is used, be sure that this second container has been flushed.

NOTE: Refer to the "Operator Services" topic in the Service chapter of this manual for detailed information regarding periodic checking and replenishing of lubricants.

Greasing

Refer to the following pages for fitting locations and greasing frequencies. Wipe dirt from the fittings before greasing them to prevent contamination. Replace any missing or damaged fittings. To minimize dirt build-up, avoid excessive greasing.



Hydraulic System Oil

Use a Mobil DTE 15M or 16M, Amoco Rykon 46, or equivalent which contains anti-rust, anti-foam and anti-oxidation additives & conforms to ISO VG46 or VG68.

Capacity:
12 U.S. gallons
(45 liters)



Chaincases

Use SAE grade motor oil

Capacity (each side):
8 U.S. quarts
(7,6 liters)

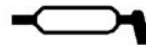

All Grease Fittings

Use Lithium-based Grease



Engine Oil (Deutz Diesel)

⊕ **Below 32°F (0°C)**
Use SAE Grade* 10 or 10W-30

⊕ **Above 32°F (0°C)**
Use SAE Grade* 15W-40

***Service Classification:**
API - CF-4/CG-4

Capacity:
8.5 U.S. quarts
(8 liters)

LUBRICATION LOCATIONS

Every 10 Hours (or daily)

1. Grease the lift arm pivots (2)
2. Grease the lift cylinder pivots (2)
3. Grease the tilt cylinder pivots (4)
4. Grease All-Tach/Quick-Tach attachment pivots (2)
5. Check the engine oil level
6. Check the hydraulic oil level

Every 100 Hours

7. Check the oil level in the chaincases
8. Check the hydraulic filter indicator

Every 500 Hours (or annually)

9. Change the hydraulic oil
10. Change the chaincase oil
11. Change the engine oil and filters*

*Refer to the engine manual for additional information on change intervals, including a 50 hour initial oil change interval.

Refer to the *Service* chapter of this manual for further details

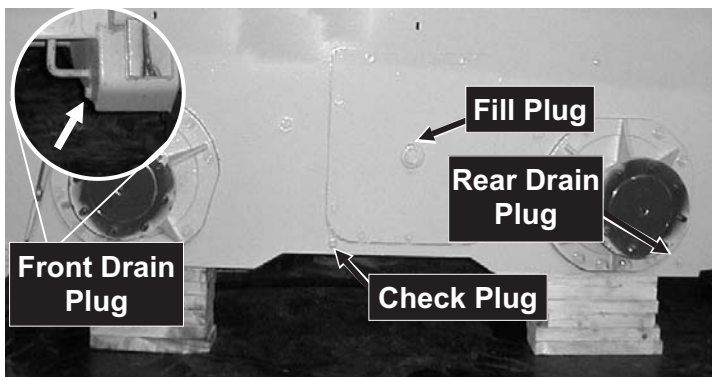

Fig. 8-1: Chaincase Oil Level Check

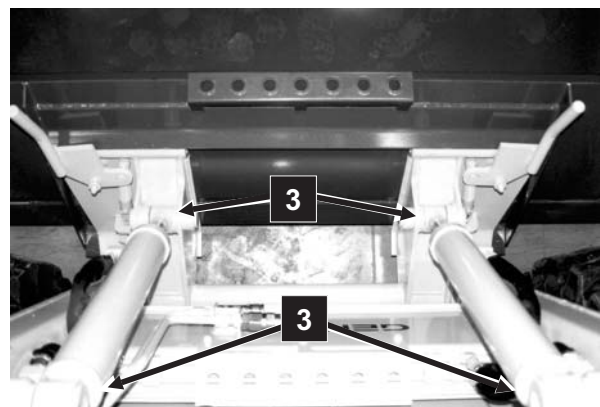

Fig. 8-2: Tilt Cylinder Grease Points

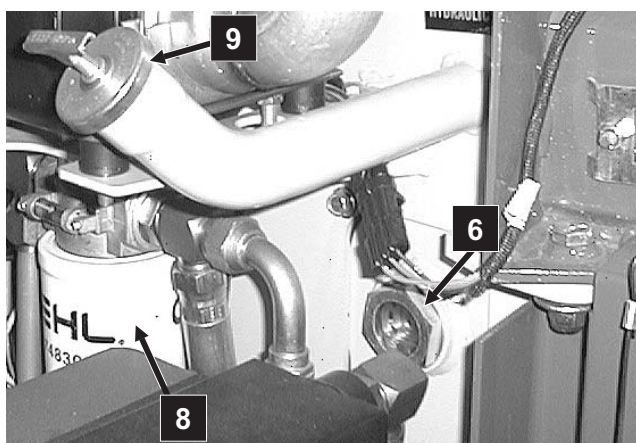

Fig. 8-3: Hydraulic Filter and Level Indicators

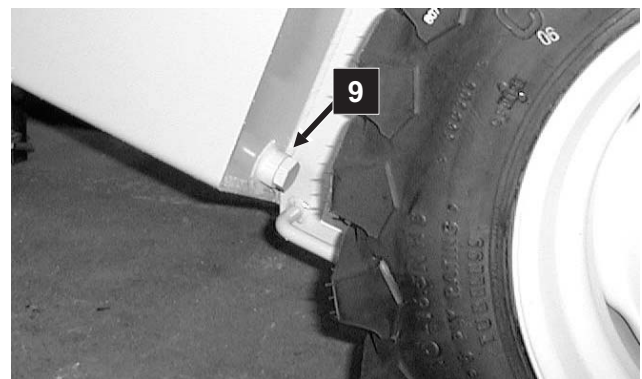
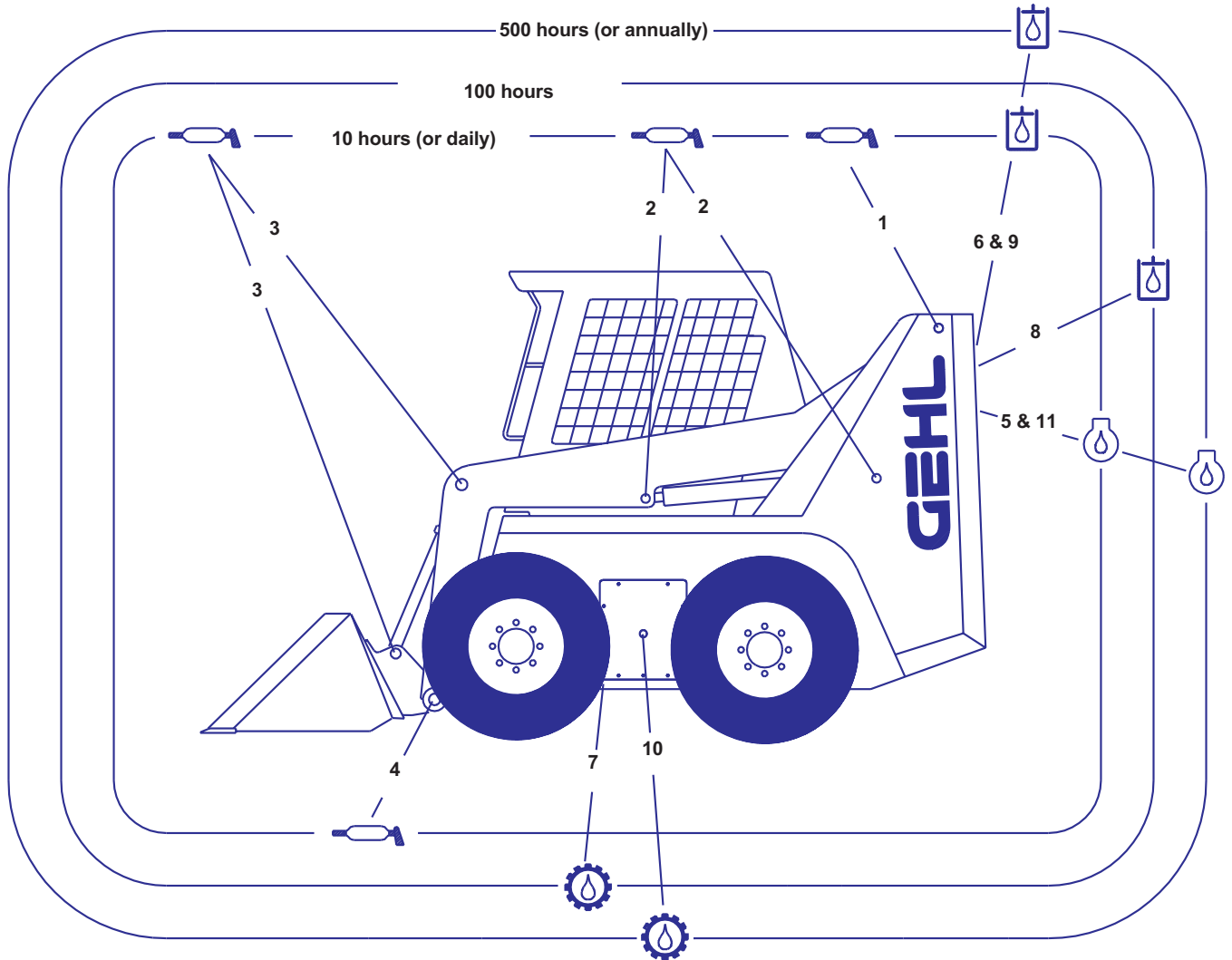

Fig. 8-4: Hydraulic Drain Plug on Right Riser

Lubrication Chart

Detailed views shown on previous page



 Engine Oil

 Grease

 Hydraulic Oil

 Chaincase Oil

CHAPTER 9

TROUBLESHOOTING

This Troubleshooting Guide lists potential problems, as well as possible causes and remedies, for Gehl skid loaders.

When a problem occurs, don't overlook simple causes. A malfunction could be caused by something as simple as an empty fuel tank. After a mechanical failure has been corrected, be sure to locate the cause of the problem.

IMPORTANT: *DO NOT attempt to service or repair major components, unless authorized to do so by your Gehl dealer. Any unauthorized repair will void the warranty.*

Electrical System

Problem	Possible Cause	Remedy
Entire electrical system does not function.	Battery disconnect switch is "Off" 20 ampere breakers are tripped.	Turn battery disconnect switch to "On". Consult wiring diagram, check circuit and locate trouble (i.e., pinched wires, faulty connections, etc.) before resetting breaker.
	Main wiring harness connectors at rear of ROPS not properly plugged in.	Check main harness connectors.
	Battery terminals or cables are loose or corroded.	Clean battery terminals and cables and retighten them.
	Battery is faulty.	Test battery and replace as needed.
No instrument panel lamps with keyswitch turned to "ON."	20 ampere breaker tripped.	Consult wiring diagram, check circuit and locate trouble before resetting breaker.
	Battery terminals or cables are loose or corroded.	Clean battery terminals and cables and retighten them.
No glow indicator lamp with key switch turned to "ON."	Ambient temperature above 32° F (0°C)	Proceed with starting engine.
	Bulb is burned out.	Replace bulb.
	Faulty glow module.	Contact your Gehl dealer for assistance.
Seat belt buzzer indicator not sounding when key turned to "ON", indicator lamps work properly.	Buzzer is disconnected.	Reconnect wires to buzzer.
	Faulty buzzer.	Replace buzzer.
Fuel gauge does not work.	Faulty fuel gauge sender.	Replace fuel gauge sender.
	Faulty fuel gauge.	Replace fuel gauge.
	Loose wiring/terminal connections.	Verify wiring connections.

Electrical System

Problem	Possible Cause	Remedy
Engine temperature gauge does not work.	Faulty temperature sender.	Replace temperature sender.
	Faulty temperature gauge.	Replace temperature gauge.
	Loose wiring/terminal connections.	Verify wiring connections.
Hour meter does not work.	Loose wiring/terminal connections.	Verify wiring connections.
	Faulty alternator.	Repair the alternator.
	Faulty hour meter.	Replace hour meter.
Starter will not engage when key is turned to "Start".	Seat or restraint bar switch malfunctioning or not activated.	Operator in the seat with the restraint bar down. Replace switches as needed. If engine still doesn't start, contact your Gehl dealer for assistance.
	Poor connections to starter relay in instrument panel.	Verify relay connections.
	Battery terminals or cables loose or corroded.	Clean terminals, cables and retighten.
	Faulty starter relay in instrument panel.	Contact your Gehl dealer for assistance.
	Battery discharged or defective.	Recharge or replace battery.
	Starter solenoid in chassis not functioning.	Troubleshoot circuit per wiring diagram, spot trouble. Replace the starter solenoid.
	Ignition wiring, seat switch, restraint bar switch, etc. loose or disconnected.	Check wiring for poor connections, broken leads; repair wiring or connection.
Starter or pinion faulty.	Remove starter; repair/replace as needed.	
Work lights not functioning properly.	Single light doesn't work: Light bulb burned out, faulty wiring.	Check and replace light bulb as needed. Check wiring connection to light.
	No lights at all: 20 ampere breaker tripped.	Refer to wiring diagram, check circuit, and locate trouble before replacing fuse.
	Faulty light switch or poor ground.	Replace light switch. Check ground wire connections.
Lift/Tilt and/or propel lock solenoids do not work.	Wiring to solenoids disconnected or faulty.	Consult wiring diagram, spot trouble, repair.
	Faulty seat or restraint bar switch.	Contact your Gehl dealer for assistance.
	Faulty solenoid valve coil.	Contact your Gehl dealer for assistance.
	Faulty hydraulic solenoid relay in instrument panel.	Contact your Gehl dealer for assistance.

Engine

Problem	Possible Cause	Remedy
Engine turns over but will not start.	Engine cranking speed too slow.	Battery requires recharging or replacing, or, in cold temperatures, pre-warm the engine.
	High flow or auxiliary valve engaged.	Return the control valves to neutral.
	Fuel tank empty or faulty fuel gauge sender.	Refill fuel tank. Replace fuel gauge sender.
	Glow module malfunctioning.	Check connection and voltage, replace as needed.
	Fuel shut-off solenoid not energizing.	Check electrical connections and voltage to shut-off solenoid.
	Engine oil not warm enough.	Install a pan heater.
	Ambient temperature is too low.	Install a pan heater.
Engine overheats.	Fuel pump not working.	Contact your Gehl dealer for assistance.
	Crankcase oil level too low or too high.	Add or remove oil as required.
	Fan air circulation blocked or restricted.	With engine OFF, remove blockage or restriction.
	Fan shroud improperly positioned.	Contact your Gehl dealer for assistance.
	Grade of oil improper or excessively dirty.	Drain and replace with proper grade new oil.
	Exhaust restricted.	Allow exhaust to cool, remove restriction.
	Air filter is restricted.	Replace the filter(s).

Hydrostatic System

Problem	Possible Cause	Remedy
No response from either the hydrostatic drive or the lift/tilt systems.	Hydraulic oil viscosity is too heavy.	Allow longer warm-up or replace existing oil with the proper viscosity oil.
	Hydraulic oil supply is too low.	Check for low oil level in reservoir. Add oil.
	Drive coupling failure.	Replace the coupling.
Traction drive will not operate in either direction.	Parking brake is engaged.	Disengage parking brake.
	Hydraulic oil supply is low.	Check for low oil level in reservoir. Add oil.
	Control rod linkage disconnected.	Check linkage connection at control levers and neutral centering mechanisms. Reconnect linkage.
	Low or no charge pressure.	Contact your Gehl dealer for assistance.
	Hydrostatic pump(s) relief valves are malfunctioning.	Contact your Gehl dealer for assistance.
Sluggish response to acceleration.	Air in the hydraulic system.	Cycle lift and tilt cylinders to maximum stroke and maintain pressure for a short time to clear air from system. Also check for low oil level in Reservoir, fill as needed.
	Automatic parking brake partially engaged.	Contact your Gehl dealer for assistance.
	Hydraulic oil supply is too low.	Check for low oil level in reservoir. Add oil.
	Low hydrostatic system charge pressure.	Contact your Gehl Dealer for assistance.
	Drive motor(s) or hydrostatic pump(s) have internal damage or leakage.	Contact your Gehl Dealer for assistance.
Hydrostatic drive is overheating.	Drive system overloaded continuously.	Improve efficiency of operation.
	Lift/tilt or auxiliary system overloaded continuously.	Improve efficiency of operation.
	Drive motor(s) or hydrostatic pump(s) have internal damage or leakage.	Contact your Gehl dealer for assistance.
	Oil cooler fins are plugged with debris.	Clean oil cooler fins.
	Loader being operated in a high temperature area with no air circulation.	Reduce duty cycle; improve air circulation.

Hydrostatic System

Problem	Possible Cause	Remedy
Hydrostatic (drive) system is noisy.	Hydraulic oil viscosity is too heavy.	Allow longer warm-up or replace existing oil with the proper viscosity oil.
	Air in hydraulic system.	Cycle lift and tilt cylinders to maximum stroke and maintain pressure for a short time to clear air from system. Also check for low oil level in reservoir, fill as needed.
	Drive motor(s) or hydrostatic pump(s) have internal damage or leakage.	Contact your Gehl dealer for assistance.
Right side doesn't drive in either direction. Left side operates normally.	Rear hydrostatic pump arm control shaft key missing.	Contact your Gehl dealer for assistance.
	Relief valves on rear hydrostatic pump malfunctioning.	Contact your Gehl dealer for assistance.
	Control rod linkage to rear hydrostatic pump disconnected.	Attach control rod linkage.
Right side doesn't drive in forward direction.	Left hand relief valve on rear hydrostatic pump is malfunctioning.	Contact your Gehl dealer for assistance.
	Rear hydrostatic pump malfunctioning.	Contact your Gehl dealer for assistance.
Right side doesn't drive in reverse direction.	Right hand relief valve on rear hydrostatic pump is malfunctioning.	Contact your Gehl dealer for assistance.
	Rear hydrostatic pump malfunctioning.	Contact your Gehl dealer for assistance.
Left side doesn't drive in either direction. Right side operates normally.	Key missing on front hydrostatic pump arm control shaft.	Contact your Gehl dealer for assistance.
	Relief valves on front hydrostatic pump malfunctioning.	Contact your Gehl dealer for assistance.
	Control rod linkage to front hydrostatic pump disconnected.	Attach control rod linkage.
Left side doesn't drive in one direction.	Relief valve on front hydrostatic pump is malfunctioning.	Contact your Gehl dealer for assistance.
	Front hydrostatic pump malfunctioning.	Contact your Gehl dealer for assistance.

Hydraulic System

Problem	Possible Cause	Remedy
Lift/Tilt controls fail to respond.	Hydraulic oil viscosity is too heavy.	Allow longer warm-up or replace with proper viscosity oil.
	Hydraulic oil level is low.	Check oil level in reservoir. If oil is low, check for an external leak. Repair and add oil.
	Solenoid valve(s) malfunctioning.	Check electrical connections to lift solenoid and repair.
	Restraint bar or seat switch malfunction.	Check switches.
Hydraulic cylinder action is slow for lift and/or tilt functions.	Low engine speed.	Operate engine at higher speed.
	Hydraulic oil viscosity is too heavy.	Allow longer warm-up or replace existing oil with proper viscosity oil.
	Control linkage is restricted.	Check for control linkage restriction and adjust.
	Hydraulic oil leaking past cylinder piston seals.	Contact your Gehl dealer for assistance.
	Worn gear pump.	Contact your Gehl dealer for assistance.
	Solenoid valve(s) could be malfunctioning.	Check electrical connections to lift solenoid and repair connections as needed. If lift solenoid valve is still not functioning properly, contact your Gehl dealer for assistance.
Jerky lift arm and bucket action.	Relief valve in control valve not functioning correctly. Squealing noise should be evident while operating.	Contact your Gehl dealer for assistance.
	Seat or restraint bar switch malfunction.	Check electrical connections to the switches. Replace as needed.
	Air in the hydraulic system.	Cycle lift and tilt cylinders to maximum stroke and maintain pressure for short time to clear air from system.
Bucket does not level on the lift cycle.	Oil in hydraulic reservoir is low.	Check and add oil to reservoir as needed.
	Self-leveling valve misadjusted or malfunctioning.	Contact your Gehl dealer for assistance.
Bucket drifts downward with tilt control in neutral.	Oil leaking past tilt cylinder seals (internal or external).	Contact your Gehl dealer for assistance.
	Self-leveling valve is malfunctioning.	Contact your Gehl dealer for assistance.
	Leaking hydraulic hoses, tubes, or fittings between control valve and cylinders.	Inspect hoses and tubes, tighten fittings. Replace hoses or tubes as needed.
No down pressure on the bucket.	Control valve in "Float" position.	Take control out of "Float" position.
	Tilt cylinders are malfunctioning.	Contact your Gehl dealer for assistance.
	Relief valve in control valve not functioning properly. Squealing noise should be evident while operating.	Contact your Gehl dealer for assistance.

Hydraulic System

Problem	Possible Cause	Remedy
Bucket will not tilt, lift arms work properly.	Tilt solenoid valve malfunctioning.	Check electrical connections to tilt solenoid and repair connections as needed. If tilt solenoid valves are still not functioning properly, contact your Gehl dealer.
	Tilt spool in control valve not actuated or leaking.	Check valve control linkage and/or tube connections to valve.
Slow or no response for bucket tilt, lift works properly (Hand & Foot units only).	Pilot control lines have air in them.	Bleed the pilot control line from the main control valve.
	Low charge pressure.	Contact your Gehl dealer for assistance.
	Linkage misadjusted between right foot pedal and pilot valve.	Readjust for full travel without restriction.
Lift arm does not raise, bucket tilt works properly.	Lift solenoid valve malfunctioning.	Check electrical connections to lift solenoid and repair connections as needed. If lift solenoid valve is still not functioning properly, contact your Gehl dealer for assistance.
	Lift spool in control valve not actuated or leaking.	Contact your Gehl dealer for assistance.
Lift arm doesn't maintain raised position with lift control in NEUTRAL.	Oil leaking past lift cylinder seals (internal or external).	Contact your Gehl dealer for assistance.
	Oil leaking past lift spool in control valve.	Contact your Gehl dealer for assistance.
	Self-leveling valve malfunctioning.	Contact your Gehl dealer for assistance.
	Leaking hydraulic hoses, tubes or fitting between control valve and cylinders.	Inspect hoses and tubes, tighten fittings as needed. Replace hoses or tubes when needed.
Lift arm will not lower or raise.	Lift arm support device engaged.	Raise lift arm and disengage support device.
	Lift solenoid valve malfunctioning.	Check electrical connections to solenoid. Repair or replace as needed.
	Restraint bar not lowered.	Lower restraint bar.
	Seat or restraint bar switch malfunction.	Check electrical connections to the switch. Replace switch as needed.
Attachment connected to high flow hydraulics stalls or has low-power (DX units only).	Relief valve on high flow manifold valve is malfunctioning.	Replace relief valve.
	Relief valve in lift/tilt control valve malfunctioning.	Replace relief valve.

CHAPTER 10

SERVICE

General Information

WARNING

BEFORE servicing the machine, unless expressly instructed to the contrary, exercise the **MANDATORY SAFETY SHUTDOWN PROCEDURE** (page 10). After service has been performed, **BE SURE** to restore all guards, shields and covers to their original positions **BEFORE** resuming loader operation.

NOTE: All service routines, except those described under the “Dealer Services” topic are owner-operator responsibilities. Refer to the *Lubrication* chapter of this manual for lubrication information.

IMPORTANT: More frequent service than the recommended intervals may be required under extreme operating conditions. You must decide if your operation requires more service.

This *Service* chapter details procedures for performing routine maintenance checks, adjustments and replacements. The majority of the procedures are referred to in the *Troubleshooting* and *Maintenance* chapters of this manual. Refer to the separate engine manual provided for engine-related adjustments and servicing procedures.

IMPORTANT: ALWAYS dispose of waste lubricating oils and hydraulic fluids according to local regulations or take to a recycling center for disposal; DO NOT pour onto the ground or down the drain.

Replacement Parts

Part numbers may change. Your Gehl dealer will have the latest part number.

Part Description	Gehl Part No.
Air Cleaner Element, Outer	L99453
Air Cleaner Element, Inner	L99967
Hydraulic Oil Filter Element, Spin-On	074830
Engine Oil Filter Element, Spin-On	132023
Fuel Filter Cartridge, Spin-On	132024

Dealer Services

The following areas of internal components service, replacement and operating adjustments require special tools and knowledge for servicing and should be performed only by your authorized Gehl skid loader dealer.

Hydrostatic Components

The hydrostatic pumps are coupled directly to each other (in tandem) and to the engine crankshaft.

Hydraulic System Gear Pump

The hydraulic system gear pump is coupled directly to the tandem hydrostatic pump.

Hydrostatic/hydraulic system schematics can be found in this chapter and used as a guide by the dealer for troubleshooting and as a service parts reference.

Valves

The valves consist of control valves and system valves.

Cylinders

The hydraulic cylinders used on the loader are designed with provisions unique to the loader application requirements.

Electrical Components

Electrical system diagrams can be found in this chapter and used as a guide by the dealer for troubleshooting and service parts reference.

Operator Services

Figures 10-1 and 10-2 show the locations of various components required for general loader services.

Service Every 10 Hours or Daily

Check Engine Oil Level (Fig. 10-2)

NOTE: For new units, the first oil change should be after the first 50 hours.

Open the engine access cover. Pull out the dipstick and check the oil level. Markings on the dipstick represent both full and low (add oil) levels. Refer to the “Change Engine Oil & Filter” subtopic under the “Service Every 500 Hours” topic in this chapter for the correct location and procedure for adding engine oil. Refer to the *Lubrication* chapter and/or the separate engine manual for oil viscosity and requirements information.

Check Hydraulic Oil Level (Fig. 10-2)

The loader has a visual hydraulic oil level indicator located on the chassis right riser. Refer to the *Lubrication* chapter for oil recommendations and to the “Hydraulic Reservoir Oil” subtopic, under the “Service Every 500 Hours” topic, for draining and replacement information.

Check Engine Air Cleaner System (Fig. 10-3)

IMPORTANT: Failure to follow proper filter servicing instructions could result in catastrophic engine damage.

The air cleaner consists of an outer primary filter element and an inner secondary filter element. An air filter restriction indicator for monitoring the condition of the elements is located on the right side of the front of the air cleaner. If the air filter becomes restricted, this indicator will turn red to warn the operator that the elements require service. Push the gauge reset button located at the end of the gauge after fitting a clean element. For replacement outer and inner elements, refer to the “Replacement Parts” topic at the beginning of this chapter.

The outer element should be replaced only when the restriction indicator reads red. The inner element should be replaced every third time the outer element is replaced or cleaned, unless the outer element is damaged or the inner element is dirty.

Along with a daily check of the indicator, check the air cleaner intake hose and clamps, and the mounting bracket hardware for secureness.

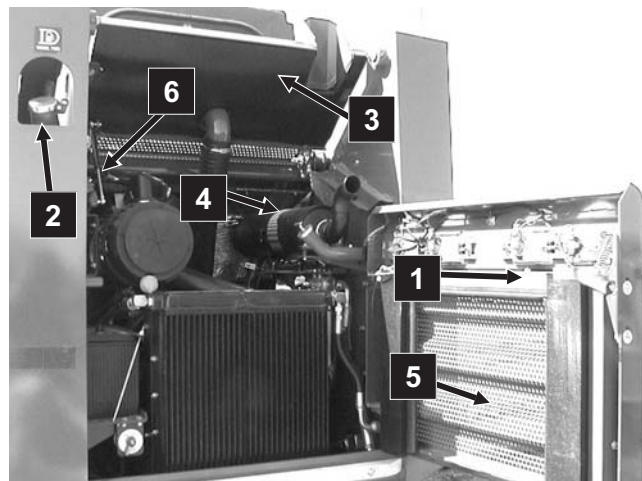

Fig. 10-1: Servicing the Loader

1. Rear Grille Latch and Release Handle
2. Fuel Fill Cap
3. Engine Access Cover
4. Muffler
5. Rear Grille
6. Gas-Charged Spring Cylinder

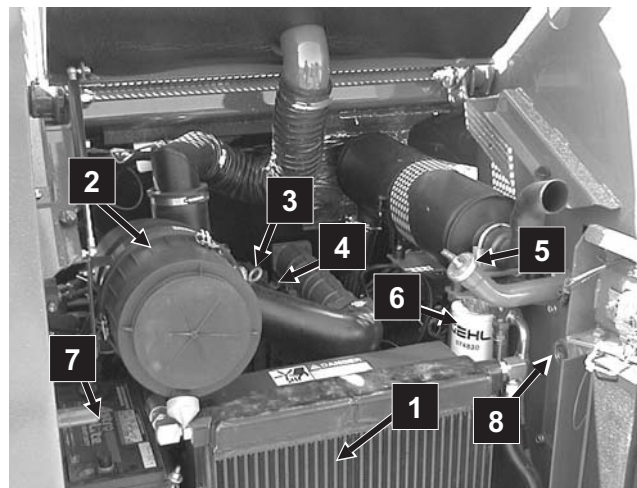

Fig. 10-2: Engine Compartment

1. Oil Cooler
2. Air Cleaner with Air Intake Hose
3. Engine Oil Dipstick
4. Engine Oil Fill Cap
5. Hydraulic Oil Fill Cap
6. Hydraulic Oil Filter
7. Battery
8. Hydraulic Oil Level Indicator

Access

1. Open the engine access cover then unlatch and open the rear grille.
2. Unlatch the three latches on the air cleaner and remove the cover. Clean out the dirt built up in the cover assembly.

Outer Element

3. Remove the outer element from the housing. NEVER remove the inner element unless it is to be replaced.
4. Clean out the dirt built up in the housing. Leave the inner element installed during this step to prevent debris from entering the engine intake manifold.
5. Gehl does not recommend repeated cleaning of the outer filter. However if it is done, use the following procedure:

Compressed Air (maximum pressure - 30 PSI):

Move the air nozzle up and down the inside of the element as you rotate it. DO NOT rap the element on a hard surface.

Use a trouble light inside the outer element to inspect for spots, pinholes or ruptures. Replace the outer element if any damage is noted. The outer element MUST be replaced if it is oil or soot-laden.

Inner Element

NOTE: Replace the inner element only if it is dirty or if the outer element has been cleaned or replaced three times.

6. Before removing the inner element from the housing, clean out the dirt built up in the housing. Leave the inner element installed during this step to prevent debris from entering the engine intake manifold. Remove the inner element.

Reinstallation

7. Check the inside of the casing for any damage that may interfere with the elements.
8. Make sure that the filter sealing surfaces are clean.
9. Insert the element(s), making sure that they are seated properly.
10. Secure the cover to the housing with the three clamps.
11. Check the tube connections and make sure they are all engaged and tightened properly.
12. Reset the indicator by pushing in the reset button located on the end of the indicator.

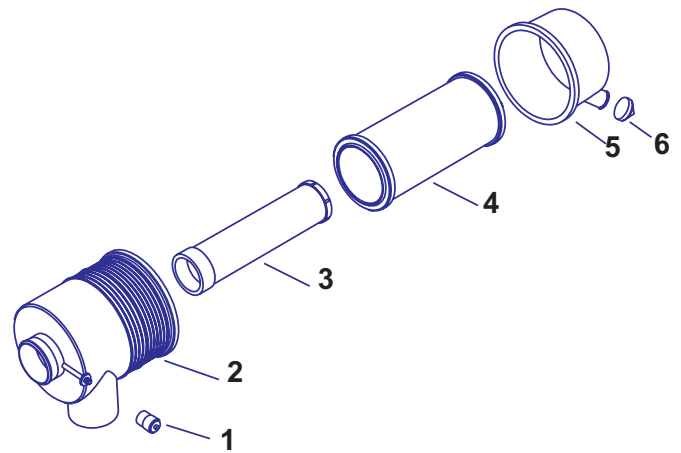

Fig. 10-3: Dual Element Air Cleaner

1. Air Cleaner Restriction Sensor Switch
2. Element Housing & Inlet Assembly
3. Inner Filter Element
4. Outer Filter Element
5. Element Cover
6. Dust Ejector

Clean Oil Cooler Fins



Allow sufficient time for the oil cooler to cool BEFORE attempting to work around it. Parts get extremely HOT during operation and can burn you.

The oil cooler assembly is mounted between the engine and the hinged rear grille. When operating correctly, air is blown through the openings between the coils and fins by the engine fan. During normal operation dust and debris builds up on the engine side of the oil cooler and restricts air flow through the fins. To reduce or remove this restriction, use compressed air or a water hose and direct the flow through the fins from the rear of the cooler towards the engine.

Grease Lift Arm, All-Tach /Quick-Tach Attachment and Cylinder Pivots

Lubricate all lift arm pivots and All-Tach /Quick-Tach attachment pivots. Lubricate the fittings on both ends of all four cylinders. Refer to details in the *Lubrication* chapter.

Check Seat and Restraint Bar Operation

Electrical switches in the seat and restraint bar **MUST** be closed (operator sitting on the seat and restraint bar lowered) to complete the circuit and start the engine.

Check Bucket Cutting Edge

The bucket cutting edge should be replaced when it is worn to within 1" (25 mm) of the bucket body.

Check Tire Pressure



Inflating or servicing tires can be dangerous. When possible, trained personnel should service and mount tires. DO NOT place your fingers on the tire bead or rim during inflation; serious injury or amputation could result. To avoid possible death or serious injury, follow the safety precautions below:

- BE SURE the rim is clean and free of rust.
- Lubricate the tire beads and rim flanges with a soap solution. Do NOT use oil or grease.
- Use a clip-on tire chuck with remote hose and gauge, allowing you to stand clear while inflating the tire.
- NEVER inflate beyond 35 PSI (240 kPa) to seat the beads. If the beads have NOT seated by the time the pressure reaches 35 PSI, deflate the assembly, reposition the tire on the rim, lubricate both parts and re-inflate. Inflation pressure beyond 35 PSI with unseated beads may break the bead or rim with explosive force sufficient to cause death or serious injury.
- After seating the beads, adjust the inflation pressure to the recommended operating pressure.
- Do NOT weld, braze or otherwise attempt to repair and use a damaged rim.

Tire Inflation Pressures

Tire Size and Description	Inflation Pressure	
	PSI	kPa
Narrow Width Heavy Duty Flotation 10 x 16.5 - 8 ply	60	415
Heavy Duty Fat Foot Flotation 31 x 13.30 x 16.5	45	310
Heavy Duty Wide Sideways Flotation 10 x 16.5 - 8 ply	60	415
Heavy Duty Wide Sideways Flotation 12 x 16.5 - 10 ply	65	450
Solid Rubber 6.5 x 16	-	-
AirBoss Segmented Industrial 7.5 x 15	-	-
AirBoss Segmented Flotation 10 x 16.5	-	-

Correct tire pressure should be maintained for all tires to enhance operating stability and extend tire life. Refer to the above chart for the proper inflation pressure.

When installing tires, BE SURE they are the same size and style on the same side of the loader. ALWAYS replace tires with the same size as the original equipment.

Service Every 100 Hours

Clean Spark Arrestor Muffler (Non-Turbo Units only)

IMPORTANT: *Non-Turbo powered loaders are factory-equipped with a USDA Forestry Service approved spark arrestor muffler. Muffler maintenance is required to keep it in working condition. Refer to local laws and regulations for spark arrestor requirements.*

To clean the muffler, open the rear grille and engine access cover. Loosen the front muffler clamp and remove the rear clamp and muffler. Dump the contents of the spark chamber and reinstall the muffler. Check that the muffler clamps are secure and, after starting the engine, that the exhaust system is quiet and NOT leaking.

Check Alternator/Fan Belt Tension and Condition

Refer to the *Adjustments* chapter and the separate engine manual for setting proper belt tension. If the belt is worn, cracked or otherwise deteriorated, replace the belt following the procedure in the separate engine manual.

Tighten Wheel Nuts, Check Drive Chain Tensions and Check Oil In Chaincases

Torque the wheel nuts to 170-180 ft-lbs (244 N·m).

Check drive chain tension following the procedure under the “Drive Chains” topic in the *Adjustments* chapter of this manual.

Each SL46/4835 drive chaincase requires 8 U.S. quarts (7,6 liters) of SAE motor oil. Fill until oil runs out of the oil level check plug. This quantity of oil should be maintained at all times.

Check Hydraulic Filter Indicator (Fig. 10-2)



Before servicing the hydraulic filter, BE SURE the lift arm is lowered.

When checking the filter indicator, STAY CLEAR of the rotating cooler fan blades. If you come in contact with the fan blades, serious injury will result.

To check the hydraulic filter element, run the engine at full throttle and normal operating temperature. Lift the engine access cover. Observe the hydraulic filter indicator located on the filter head. If the indicator is green, the filter does not need replacing. If the indicator is red, replace the filter following the instructions below.

1. Turn OFF the engine.
2. Open the reservoir drain plug located in front of the right rear tire.
3. Drain the oil out to a level below the point where the filter attaches to the reservoir.
4. Replace the reservoir drain plug.
5. Refill the hydraulic oil reservoir with oil. Refer to the *Lubrication* chapter for hydraulic reservoir oil recommendations.
6. Spin off the old hydraulic filter element and spin on the new filter element.

For replacement spin-on hydraulic filter element, refer to the “Replacement Parts” topic at the beginning of this chapter.

Service Every 500 Hours or Yearly

Check Engine Mounting Hardware

ALL bolts which secure the engine mounting brackets to the engine and the loader frame should be checked and re-tightened, as necessary.

Check Battery

WARNING

Before servicing the battery or electrical system, be sure the battery disconnect switch (if equipped) is in the “OFF” position. If not equipped with a disconnect switch, disconnect the ground (-) terminal from battery.

The battery on the loader is a 12 volt, wet-cell battery. To access the battery, lift the engine access cover, unlatch and open the rear grille.

The battery top **MUST** be kept clean. Clean it with an alkaline solution (ammonia or baking soda and water). After foaming has stopped, flush the battery top with clean water. If the terminals and cable connection clamps are corroded or have a build-up, disconnect the cables and clean the terminals and clamps with the same alkaline solution.

Handling the Battery Safely

WARNING

Explosive gas is produced while a battery is in use or being charged. Keep flames or sparks away from the battery area. ALWAYS charge the battery in a well-ventilated area.

NEVER lay a metal object on top of a battery, because a short circuit can result.

Battery acid is harmful on contact with skin or fabrics. If acid spills, follow these first aid tips:

- 1. IMMEDIATELY** remove any clothing on which acid spills.
- 2. If acid contacts the skin, rinse the affected area with running water for 10 to 15 minutes.**
- 3. If acid contacts the eyes, flood the eyes with running water for 10 or 15 minutes. See a doctor at once. NEVER use any medication or eye drops unless prescribed by the doctor.**
- 4. To neutralize acid spilled on the floor, use one of the following mixtures:**
 - a. 1 pound (0,5 kilogram) of baking soda in 1 gallon (4 liters) of water**
 - b. 1 pint (0,5 liters) of household ammonia in 1 gallon (4 liters) of water**

Whenever the battery is removed, BE SURE to disconnect the negative (-) battery terminal connection first.

Jump-Starting

If the battery becomes discharged or does not have enough power to start the engine, use jumper cables and the following procedure to jump-start the loader engine.

WARNING

The ONLY safe method for jump-starting a discharged battery is for TWO PEOPLE to perform the following procedure. The second person removes the jumper cables so that the operator does not have to leave the operator's compartment with the engine running. NEVER make jumper cable connections directly to the starter solenoid of either engine. DO NOT start the engine from any position other than on the operator's seat and then ONLY after being sure ALL controls are in "neutral."

Closely follow the procedure, in order, to avoid personal injury. In addition, wear safety glasses to protect your eyes and avoid leaning over the batteries while jump-starting.

DO NOT jump-start the battery if it is frozen, because it may rupture or explode.

NOTE: *BE SURE the jumper battery is a 12 volt D.C. battery.*

1. Turn the keyswitches of both vehicles to OFF, be sure the vehicles are in "neutral" and NOT touching each other.
2. Connect the positive (+) jumper cable to the positive (+) battery terminal on the disabled loader first. DO NOT allow the jumper's positive cable clamps to touch any metal other than the positive (+) battery terminals.
3. Connect the other end of the positive jumper cable to the jumper vehicle's battery positive (+) terminal.
4. Connect the negative (-) jumper cable to the jumper vehicle's battery negative (-) terminal.
5. Make the final negative (-) jumper cable connection to the disabled loader's engine block or loader frame (ground) — NOT to the disabled battery's negative post. If connected to the engine, keep the jumper clamp away from the battery, fuel lines and moving parts.

6. Start the loader. If it does not start at once, start the jumper vehicle engine to avoid excessive drain on the booster battery.
7. After the disabled loader is started and running smoothly, have the second person remove the jumper cables (negative (-) jumper cable first) from the jumper vehicle's battery and then from the disabled loader while being sure NOT to short the two cables together.

Allow sufficient time for the skid loader alternator to build-up a charge in the battery before attempting to operate the loader or shut the engine off.

Change Hydraulic Oil (Fig. 10-2)

The hydraulic oil is contained in the reservoir (and in hoses and other hydraulic system components).

1. Turn OFF the engine.
2. Open the reservoir drain plug located in front of the right rear tire.
3. Drain the oil out.
4. Replace the reservoir drain plug.
5. Refill the hydraulic oil reservoir with oil. Refer to the *Lubrication* chapter for hydraulic reservoir oil recommendations.

Change Engine Oil & Filter (Figs. 10-4 to 10-6)

NOTE: For new units, the first oil change should be after the first 50 hours.

IMPORTANT: ALWAYS dispose of waste lubricating oils according to local regulations or take to a recycling center for disposal; DO NOT pour onto the ground or down the drain.

Oil should be changed when the engine is at normal operating temperature. When the engine has been drained, the loader should be marked so that it is not accidentally operated before being refilled.

The loader has an engine oil filter located on the left side of the engine, in front of the battery. Follow the “ROPS/FOPS & Lock Mechanism” procedure in the *Controls & Safety Equipment* chapter to lift up the ROPS and access the filter.

Before removing the oil filter, remove the rear skid plate cover to drain the engine filter oil (fig. 10-4).

To add new oil, open the engine access cover. Remove the oil cap and add the recommended oil. Refer to the *Lubrication* chapter in this manual for oil recommendations and quantity; and to the separate engine manual for oil and oil filter changing procedures. Visually inspect the remote oil drain hose for damage or leaks.

For a replacement spin-on oil filter element, refer to the “Replacement Parts” topic at the beginning of this chapter.

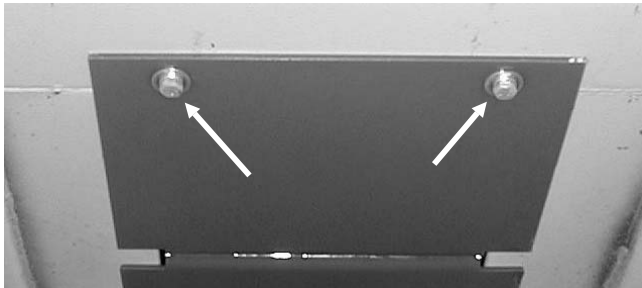

Fig. 10-4: Rear Skid Plate Cover Bolts

Change Fuel Filter (Fig. 10-5)

The loader has a fuel filter located on the left side of the engine, in front of the battery. Follow the “ROPS/FOPS & Lock Mechanism” procedure in the *Controls & Safety Equipment* chapter to lift up the ROPS and access the filter. Clamp off the fuel line to stop fuel flow BEFORE replacing the filter. Remove the spin-on filter cartridge. Install the new cartridge and check for leaks.

For a replacement spin-on fuel filter cartridge, refer to the “Replacement Parts” topic at the beginning of this chapter.

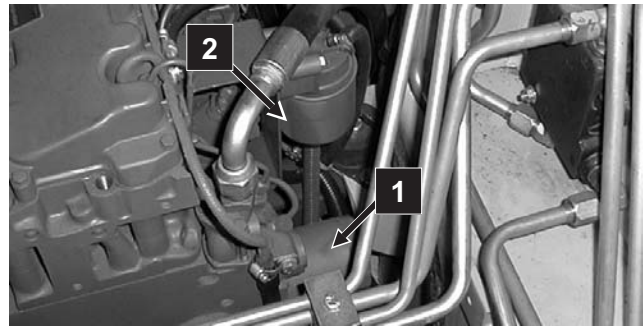

Fig. 10-5: Changing the Oil & Fuel Filters

1. Engine Oil Filter
2. Fuel Filter

Change Chaincase Oil (Fig. 10-6)

Raise the loader off the ground following the “Loader Raising Procedure” in the *Adjustments* chapter in this manual.

1. Remove the front and rear drain plugs and drain the oil.
2. Reinstall the drain plugs.
3. Remove both the fill and oil level check plugs.
4. Add oil through the fill plug until oil starts to flow out of the check plug.
5. Reinstall the check plug, then the fill plug.

Follow the “Loader Lowering Procedure” at the beginning of the *Adjustments* chapter to return the loader to the ground.

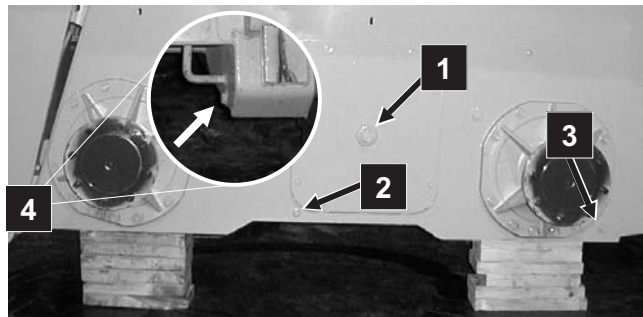
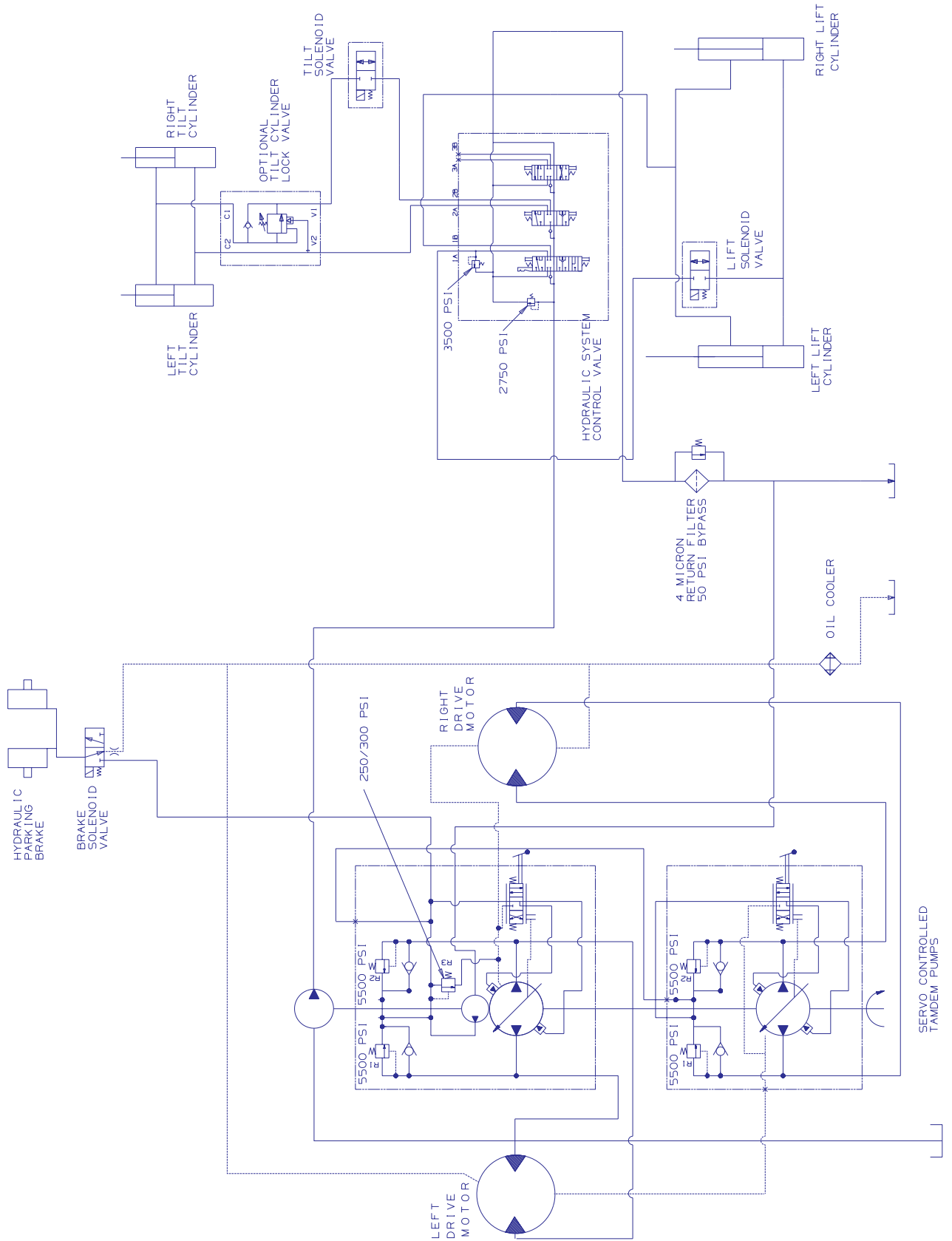

Fig. 10-6: Changing the Chaincase Oil

1. Chaincase Fill Plug
2. Check Plug
3. Rear Chaincase Drain Plugs
4. Front Chaincase Drain Plugs

SL4635 Hydrostatic/Hydraulic Schematic



SL46/4835X Hydrostatic/Hydraulic Schematic

SN300119 and later - SL4635; SN400121 and later SL4835

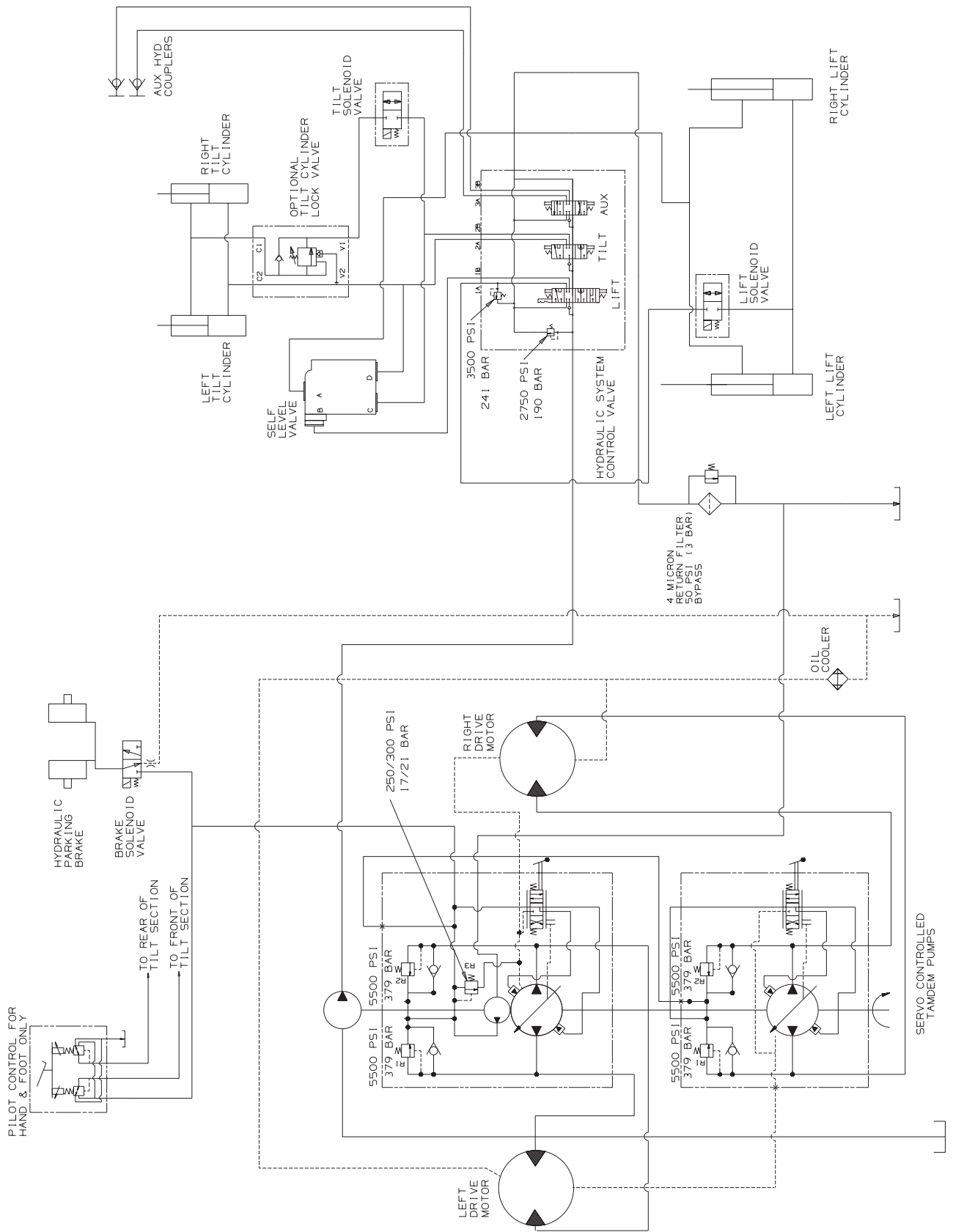

SL46/4835SX Hydrostatic/Hydraulic Schematic

Before SN300119 - SL4635; Before SN400121 - SL4835

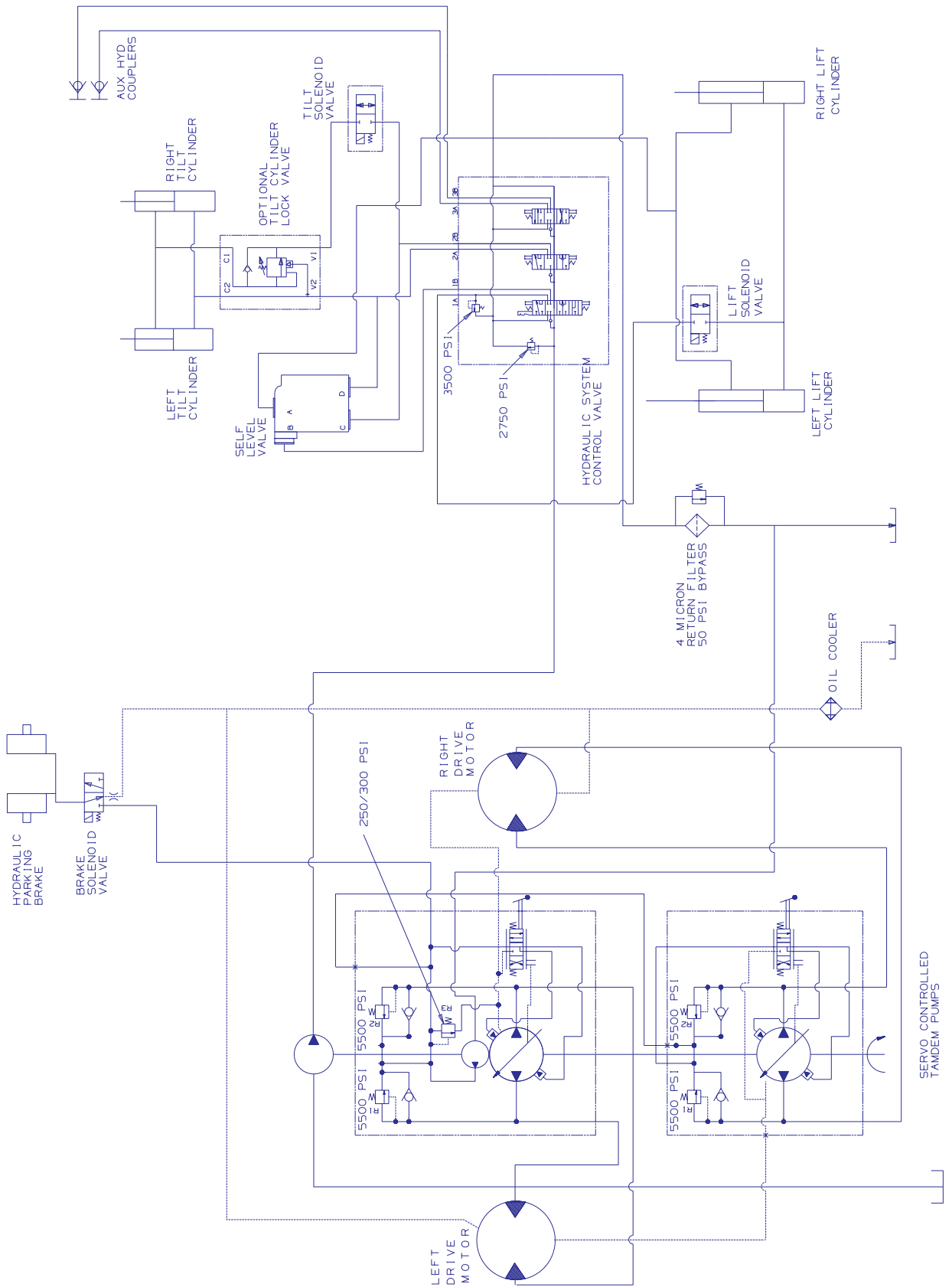

SL46/4835DX Hydrostatic/Hydraulic Schematic

SN300119 and later - SL4635; SN400121 and later - SL4835

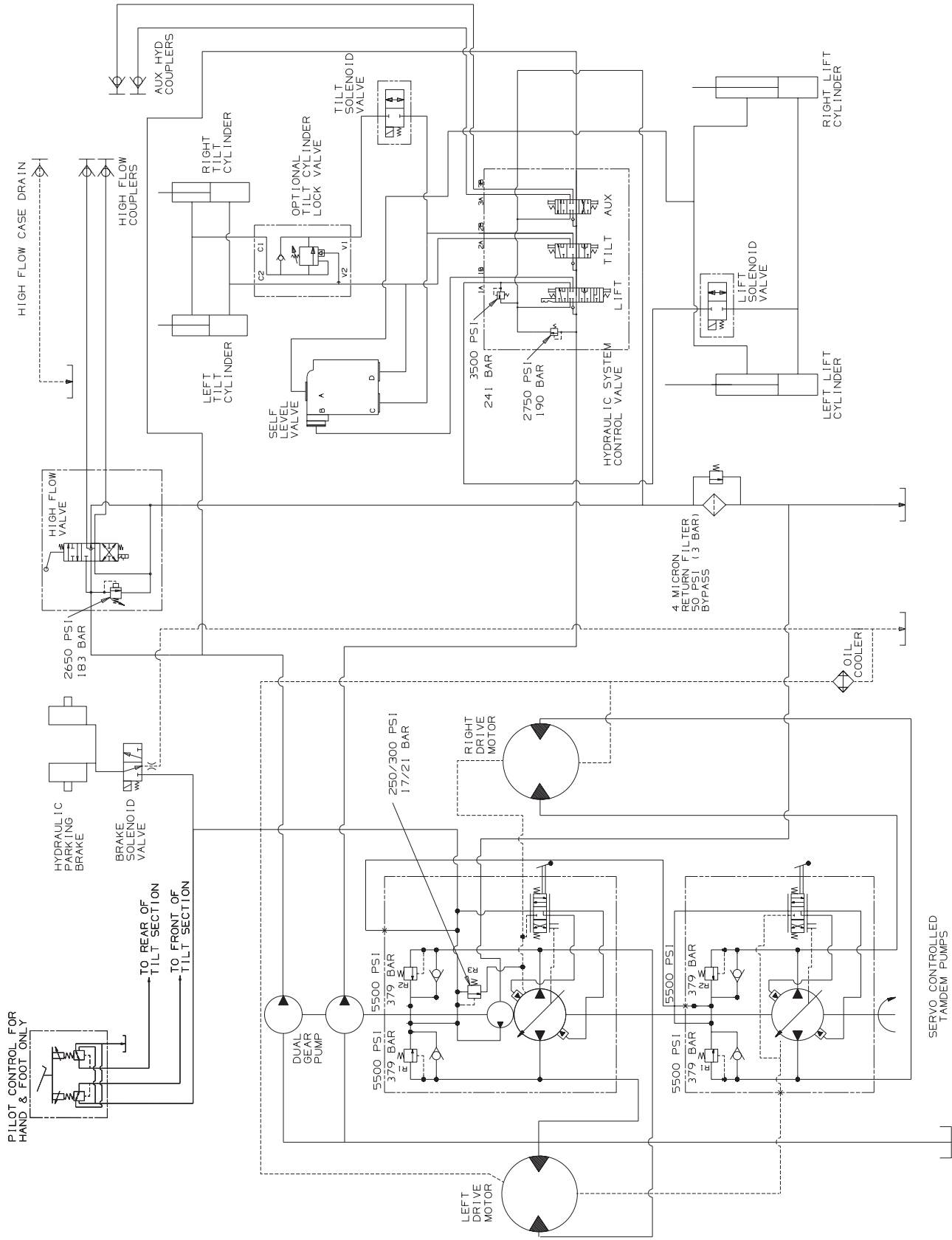

SL46/4835DX Hydrostatic/Hydraulic Schematic

Before SN300119 - SL4635; Before SN400121 - SL4835

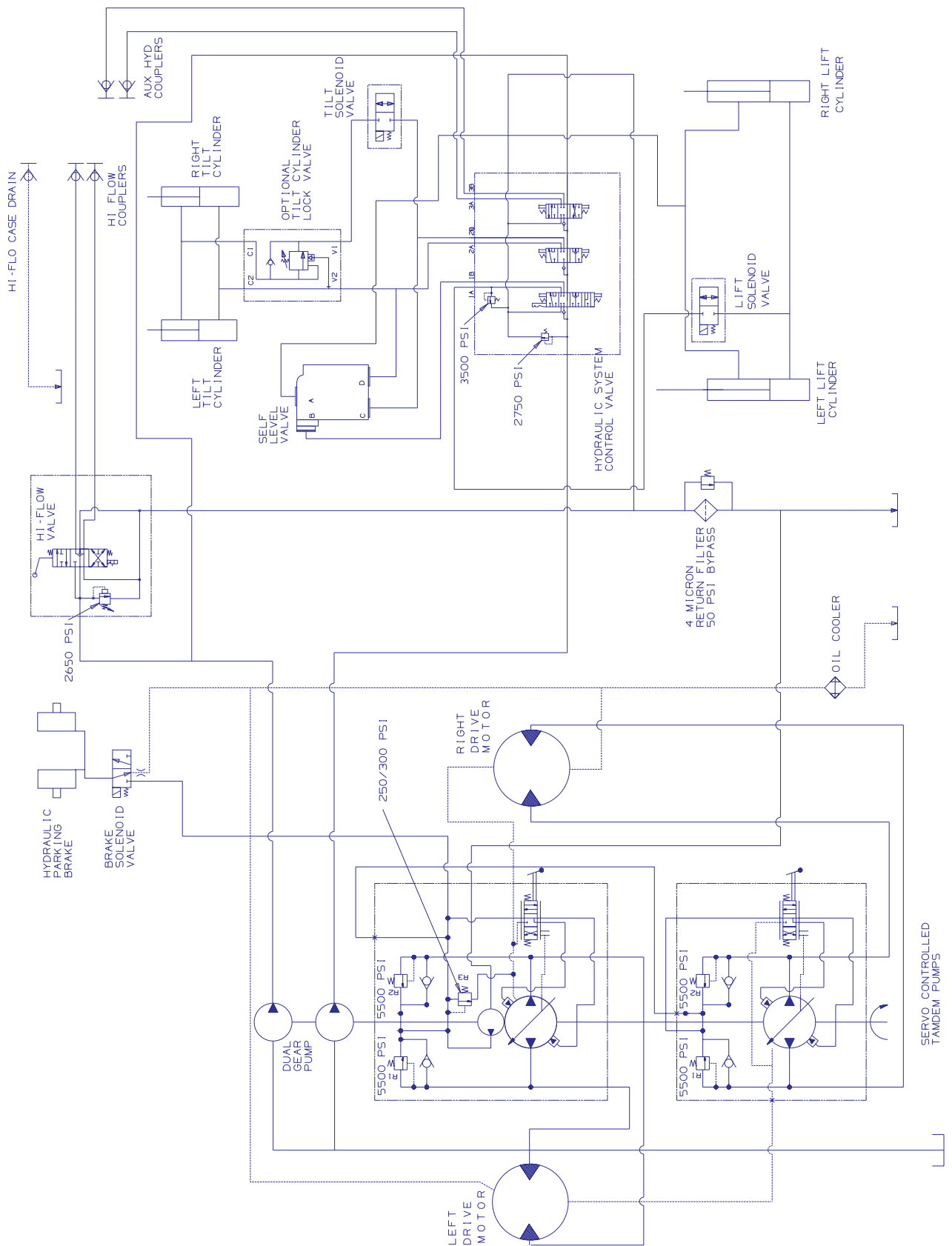

SL46/4835 Electrical Schematic

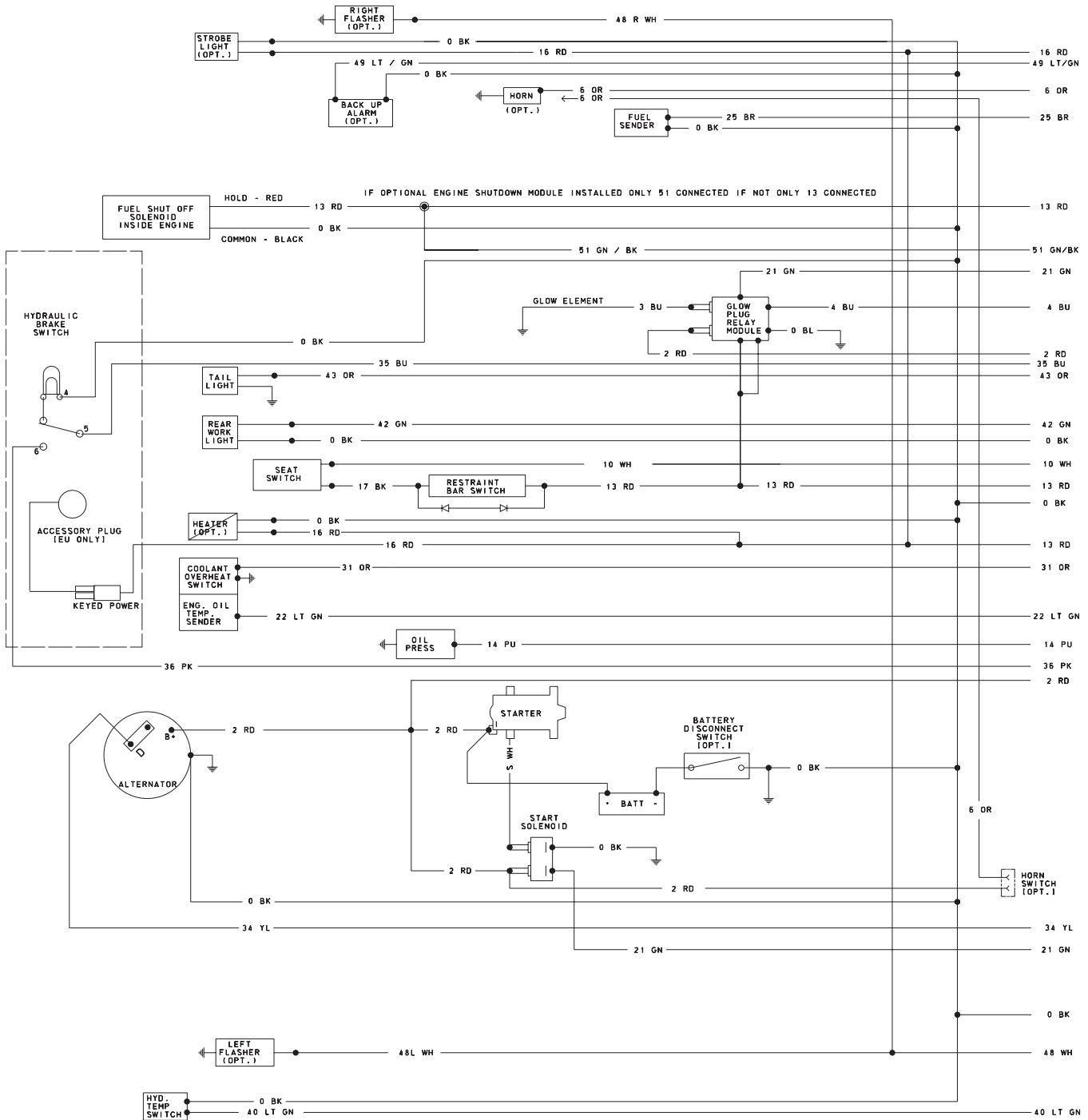

SL46/4835 Electrical Schematic

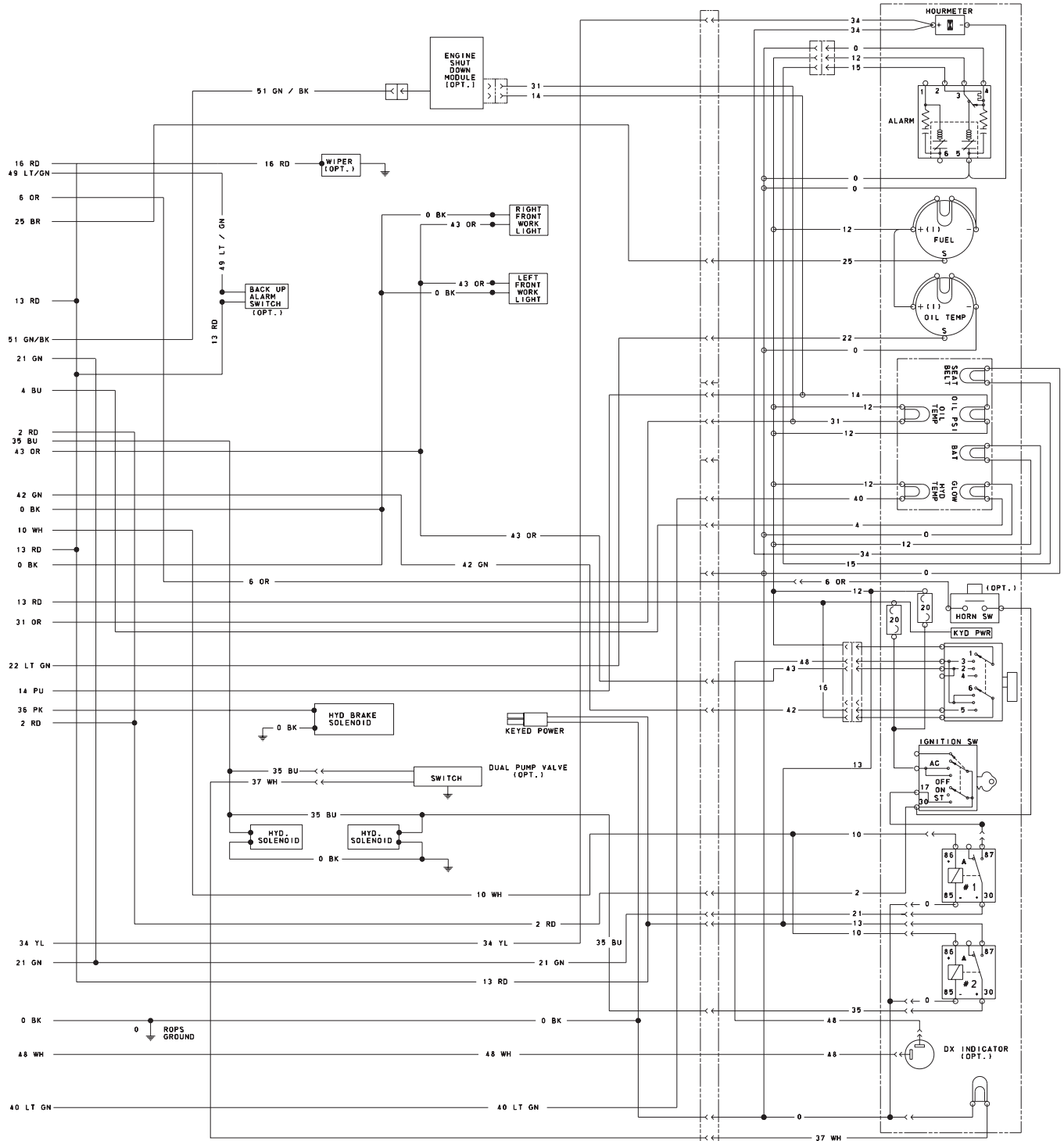

CHAPTER 11

MAINTENANCE SCHEDULE

This Maintenance Interval Chart was developed to match the *Service* chapter of this manual. Detailed information on each service procedure may be found in the *Service* chapter. A Maintenance Log follows the Interval Chart for recording the maintenance procedures performed. Recording the 10 hour (or daily) service intervals would be impractical and is therefore not recommended.

IMPORTANT: *Under extreme operating conditions more frequent service than the recommended intervals may be required. You must decide if your operation requires more frequent service based on your use.*

Maintenance Interval Chart

Service Procedure	Every 10 Hours (or Daily)	Every 100 Hours	Every 500 Hours (or Annually)
Check Engine Air Cleaner Restriction Indicator	●		
Check Engine Oil Level	●		
Check Hydraulic Oil Level	●		
Check Tire Pressures	●		
Grease Lift Arm, Attachment Mechanism and Cylinder Pivots	●		
Check Bucket Cutting Edge	●		
Check Seat & Restraint Bar Operation	●		
Check Oil Cooler Fins	●		
Check Hydraulic Filter Element Indicator		●	
Check Wheel Nuts Torque (170-180 ft-lbs)		●	
Check Drive Chain Tension		●	
Check Oil Level in Chaincases		●	
Clean Spark Arrestor Muffler (Non-Turbo Units)		●	
Check Alternator/Fan Belt Tensions		●	
Check Battery			●
Check Engine Mounting Hardware			●
Change Fuel Filter			●
Change Hydraulic Oil			●
Change Engine Oil & Filter ♦			●
Change Chaincase Oil			●

♦ For new units, the first oil change should be after the first 50 hours. Refer to the engine manual for additional information.

NOTE: *Continue to repeat the service procedures at every specified time interval.*

Maintenance Log

Date	Hours	Service Procedure

Maintenance Log

Date	Hours	Service Procedure

Maintenance Log

Date	Hours	Service Procedure

INDEX

A

Accelerator Pedal	19
Adjustments	46
Accessories	5
ADJUSTMENTS	45
Accelerator Pedal	46
Control Handles	46
Electric Auxiliary Controls	48
Throttle Lever	46
Air Cleaner	60
All-Tach Attachment Mounting	32
Changing Attachments	38
Auxiliary Hydraulics	
Controls	See specific control type
High Flow Auxiliary Hydraulics	34
Standard Flow Auxiliary Hydraulics	34

B

Battery	64
Battery Disconnect Switch	29

C

Chaincase Oil	66
CHECKLISTS	7,9
Cold Starting Procedure	36
Control Panel	30
CONTROLS & SAFETY EQUIPMENT	19

D

Dealer Services	59
Cylinders	59
Electrical Components	59
Hydraulic System Gear Pump	59
Hydrostatic Components	59
Valves	59
Drive Chains	46
Adjust Chain Tension	47
Dual Hand Controls	
Auxiliary Hydraulics	26
Drive Control Handles	26
Lift/Tilt Control Handles	26

E

Emergency Exit	29
Engine	
Adjustments	46
Changing Engine Oil & Filter	66
Checking Engine Oil Level	60

F

First Time Operation	36
Fuel Filter	66
Fuel Sender	46

G

Gas-Charged Spring Cylinder	
Engine Cover	60
ROPS/FOPS	29
Greasing	49
Guards and Shields	19

H

Hand & Foot Controls, Electric	
Auxiliary Hydraulics	22
Drive Control Handles	22
Lift/Tilt Foot Pedals	22
Hand & Foot Controls, Mechanical	
Auxiliary Hydraulics	24
Drive Control Handles	24
Lift/Tilt Foot Pedals	24
Highway Travel	44
Hydraulic Filter	63
Hydraulic Oil	65
Checking Hydraulic Oil Level	60

I

Instrument Panel	30
Interlock System	32
International Symbols	inside front cover
INTRODUCTION	2

J

Jump-Starting	65
-------------------------	----

L	
Lift Arm Support Device	32
Disengagement	33
Engagement	33
Lifting the Loader	44
Loader Identification	3
Loader Lowering Procedure	45
Loader Movement	36
Loader Operations	41
Digging with and Loading a Bucket	41
Dumping the Load Into a Box	42
Dumping the Load Onto a Pile	41
Dumping the Load Over A Solid Embankment	42
Leveling with a Bucket	43
Scraping with a Bucket	42
Loader Raising Procedure	45
LUBRICATION	49
Lubricants	49
Lubrication Chart	51
Lubrication Locations	50

M	
MAINTENANCE SCHEDULE	74
Maintenance Interval Chart	74
Maintenance Log	75,76,77
MANDATORY SAFETY SHUTDOWN PROCEDURE 10	
Material Densities	40
MODEL SPECIFICATIONS	
Accessories	5
General Specifications	6
Standard Features	5
Muffler, Cleaning	63

O	
Oil Cooler Fins, Cleaning	61
OPERATION	35
Operator Services	60,63,64

P	
Parking Brake	28

Q	
Quick-Tach Attachment Mounting	32
Changing Attachments	39

R	
Replacement Parts	59
Restraint Bar	28
ROPS/FOPS	
Lock Mechanism	29



S	
SAFETY	10
Additional Safety Reminders	11
Schematics	
SL46/4835 Electrical	72
SL46/4835 Electrical	73
SL46/4835DX Hydrostatic/Hydraulic	70,71
SL46/4835SX Hydrostatic/Hydraulic	68,69
SL4635 Hydrostatic/Hydraulic	67
Seat Positioning	28
SERVICE	59
Standard Features	5
Starting The Loader	35
Stopping The Loader	36
Storage	44



T	
Table of Common Materials and Densities	40
T-Bar Controls	
Auxiliary Hydraulics	20
Drive Control T-Bar	20
Lift/Tilt Control T-Bar	20
Throttle Lever	19
Adjustments	46
Tires	
Pressure	62
TORQUE SPECIFICATIONS	80
Transportation	44
TROUBLESHOOTING	52
Electrical System	52,53
Engine	54
Hydraulic System	57,58
Hydrostatic System	55,56

W	
Warranty	inside back cover
Window, Rear	29

TORQUE SPECIFICATIONS

Use these torque values when tightening Gehl hardware (excluding: locknuts, and self-tapping, thread forming, and sheet metal screws) unless otherwise specified.

UNIFIED NATIONAL THREAD	GRADE 2 		GRADE 5 		GRADE 8 	
	DRY	LUBED	DRY	LUBED	DRY	LUBED
8-32	19*	14*	30*	22*	41*	31*
8-36	20*	15*	31*	23*	43*	32*
10-24	27*	21*	43*	32*	60*	45*
10-32	31*	23*	49*	36*	68*	51*
1/4-20	66*	50*	9	75*	12	9
1/4-28	76*	56*	10	86*	14	10
5/16-18	11	9	17	13	25	18
5/16-24	12	9	19	14	25	20
3/8-16	20	15	30	23	45	35
3/8-24	23	17	35	25	50	35
7/16-14	32	24	35	35	70	55
7/16-20	36	27	40	40	80	60
1/2-13	50	35	75	55	110	80
1/2-20	55	40	90	65	120	90
9/16-12	70	55	110	80	150	110
9/16-18	80	60	120	90	170	130
5/8-11	100	75	150	110	220	170
5/8-18	110	85	180	130	240	180
3/4-10	175	130	260	200	380	280
3/4-16	200	150	300	220	420	320
7/8-9	170	125	430	320	600	460
7/8-14	180	140	470	360	660	500
1-8	250	190	640	480	900	680
1-12	270	210	710	530	1000	740

METRIC COARSE THREAD	GRADE 8.8 		GRADE 10.9 		GRADE 12.9 	
	DRY	LUBED	DRY	LUBED	DRY	LUBED
M6-1	8	6	11	8	13.5	10
M8-1.25	19	14	27	20	32.5	24
M10-1.5	37.5	28	53	39	64	47
M12-1.75	65	48	91.5	67.5	111.5	82
M14-2	103.5	76.5	145.5	108	176.5	131
M16-2	158.5	117.5	223.5	165.5	271	200

*All Torque Values are in ft-lbs except those marked with an * which are in in-lbs.
For metric torque value (N·m) multiply ft-lbs value by 1.355 or the in-lbs value by 0.113.

GEHL COMPANY

WARRANTY

GEHL COMPANY, hereinafter referred to as Gehl, warrants new Gehl Skid Loaders to the Original Retail Purchaser to be free from defects in material and workmanship for a period of twelve (12) months from the Warranty Start Date.

GEHL WARRANTY SERVICE INCLUDES:

Genuine Gehl parts and labor costs required to repair or replace equipment at the selling dealer's business location.

GEHL MAKES NO REPRESENTATIONS OR WARRANTIES OF ANY KIND, EXPRESS OR IMPLIED (INCLUDING THE IMPLIED WARRANTIES OF MERCHANTABILITY AND FITNESS FOR PARTICULAR PURPOSE), EXCEPT AS EXPRESSLY STATED IN THIS WARRANTY STATEMENT.

GEHL WARRANTY DOES NOT INCLUDE:

1. Transportation to selling dealer's business location or, at the option of the Original Retail Purchaser, the cost of a service call.
2. Used equipment.
3. Components covered by their own non-Gehl warranties, such as tires, trade accessories and engines.
4. Normal maintenance service and expendable, high wear items.
5. Repairs or adjustments caused by: improper use; failure to follow recommended maintenance procedures; use of unauthorized attachments; accident or other casualty.
6. Liability for incidental or consequential damages of any type, including, but not limited to lost profits or expenses of acquiring replacement equipment.

No agent, employee or representative of Gehl has any authority to bind Gehl to any warranty except as specifically set forth herein. Any of these limitations excluded by local law shall be deemed deleted from this warranty; all other terms will continue to apply.

GEHL[®]

Gehl Company 143 Water Street, P.O. Box 179, West Bend, WI 53095-0179 U.S.A.

California Proposition 65 Warning

Diesel engine exhaust and some of its constituents are known to the State of California to cause cancer and birth defects or other reproductive harm.

Battery posts, terminals and related accessories contain lead and lead compounds, chemicals known to the State of California to cause cancer and birth defects or other reproductive harm. Wash hands after handling battery.