

ENGR-1100 Introduction to Engineering Analysis

Lecture 9

MOMENT OF A FORCE (SCALAR FORMULATION), CROSS PRODUCT, MOMENT OF A FORCE (VECTOR FORMULATION), & PRINCIPLE OF MOMENTS

Today's Objectives :

Students will be able to:

- a) understand and define moment, and,
- b) determine moments of a force in 2-D and 3-D cases.



In-Class Activities :

- Reading Quiz
- Applications
- Moment in 2-D
- Moment in 3-D
- Concept Quiz
- Group Problem Solving
- Attention Quiz



APPLICATIONS

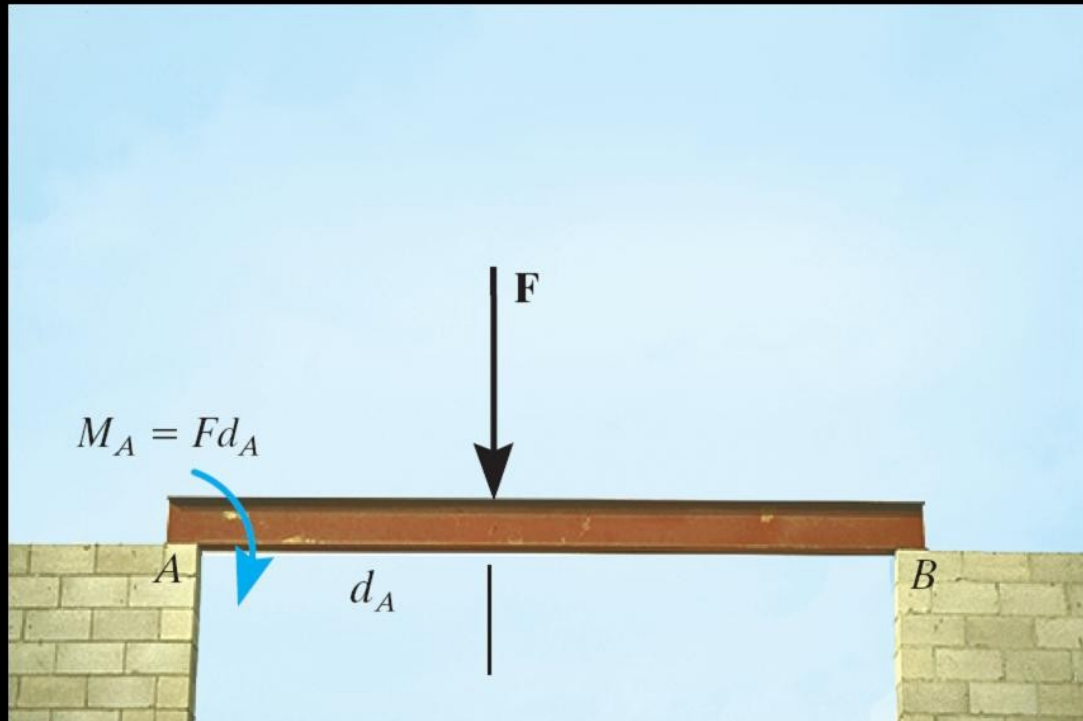

Beams are often used to bridge gaps in walls.
We have to know what the effect of the force on
the beam will have on the supports of the beam.

What do you think is happening at points A and B?

APPLICATIONS (continued)



Carpenters often use a hammer in this way to pull a stubborn nail. Through what sort of action does the force F_H at the handle pull the nail? How can you mathematically model the effect of force F_H at point O ?



MOMENT OF A FORCE - SCALAR FORMULATION (Section 4.1)

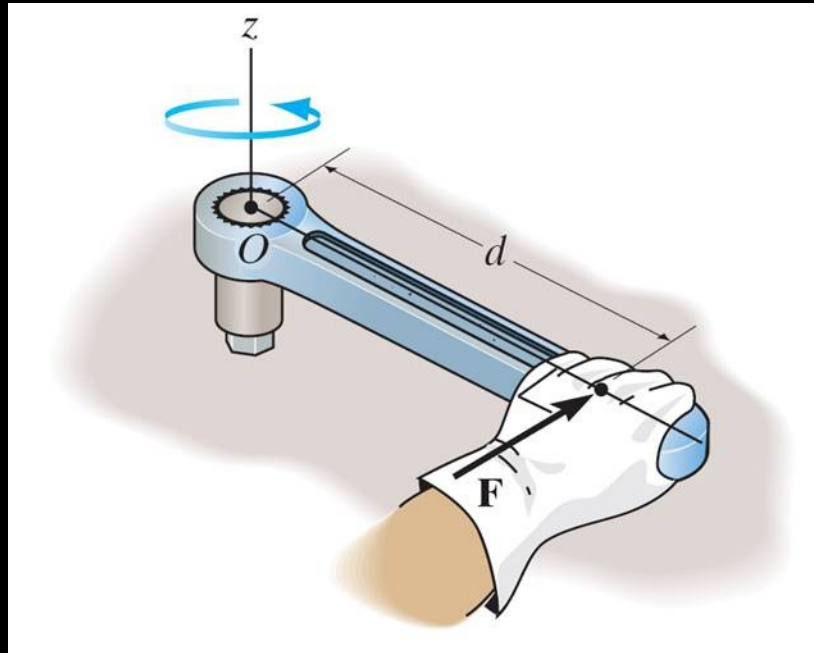

The **moment** of a force about a point provides a measure of the tendency for rotation (sometimes called a torque).



MOMENT OF A FORCE - SCALAR FORMULATION

(continued)

In a 2-D case, the **magnitude** of the moment is $M_o = F d$

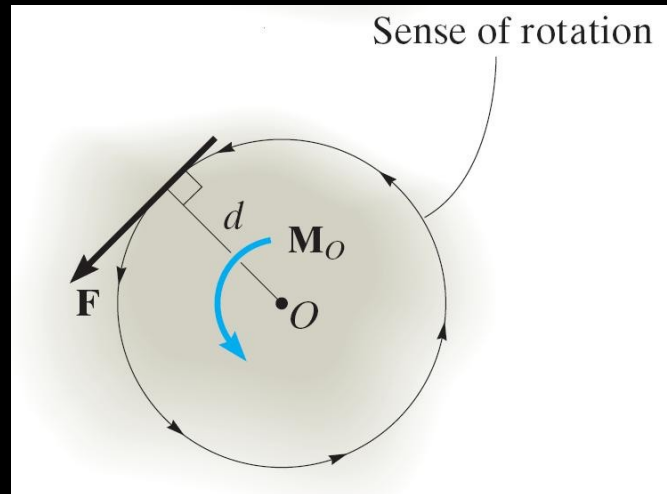

As shown, d is the **perpendicular** distance from point O to the **line of action** of the force.

In 2-D, the **direction** of M_o is either clockwise (CW) or counter-clockwise (CCW), depending on the tendency for rotation.



MOMENT OF A FORCE - SCALAR FORMULATION

(continued)

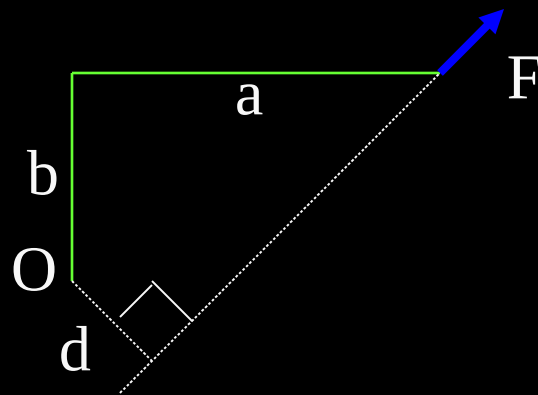

For example, $M_O = F d$ and the direction is counter-clockwise.

Often it is easier to determine M_O by using the components of F as shown.

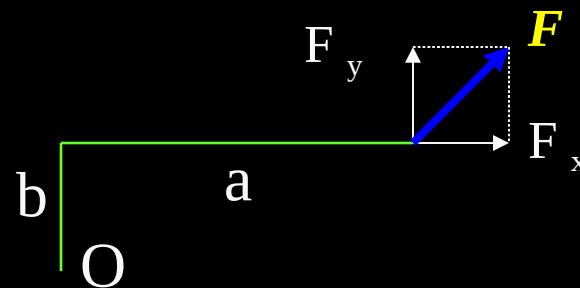

Then $M_O = (F_y a) - (F_x b)$. Note the different signs on the terms! The typical sign convention for a moment in 2-D is that counter-clockwise is considered positive. We can determine the direction of rotation by imagining the body pinned at O and deciding which way the body would rotate because of the force.



VECTOR CROSS PRODUCT (Section 4.2)

While finding the moment of a force in 2-D is straightforward when you know the perpendicular distance d , finding the perpendicular distances can be hard—especially when you are working with forces in three dimensions.

So a more general approach to finding the moment of a force exists. This more general approach is usually used when dealing with three dimensional forces but can be used in the two dimensional case as well.

This more general method of finding the moment of a force uses a vector operation called the cross product of two vectors.



CROSS PRODUCT (Section 4.2)

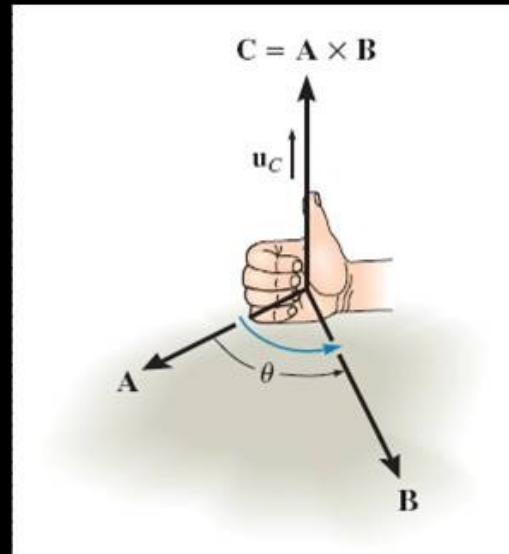

In general, the cross product of two vectors A and B results in another vector, C , i.e., $C = A \times B$. The magnitude and direction of the resulting vector can be written as

$$C = A \times B = AB \sin \theta u_c$$

As shown, u_c is the unit vector perpendicular to both A and B vectors (or to the plane containing the A and B vectors).



CROSS PRODUCT (continued)

The right-hand rule is a useful tool for determining the direction of the vector resulting from a cross product.

For example: $\mathbf{i} \times \mathbf{j} = \mathbf{k}$

Note that a vector crossed into itself is zero, e.g., $\mathbf{i} \times \mathbf{i} = \mathbf{0}$

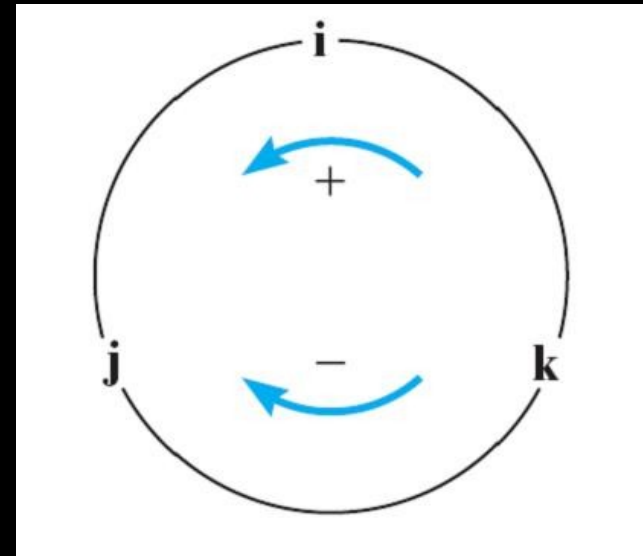
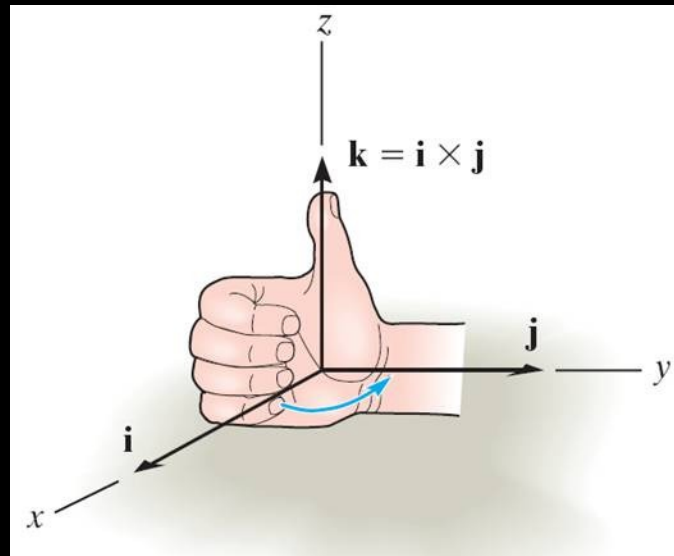

CROSS PRODUCT (continued)

Also, the cross product can be written as a determinant.

$$\mathbf{A} \times \mathbf{B} = \begin{vmatrix} \mathbf{i} & \mathbf{j} & \mathbf{k} \\ A_x & A_y & A_z \\ B_x & B_y & B_z \end{vmatrix}$$

Each component can be determined using 2×2 determinants.

For element **i**: $\begin{vmatrix} \mathbf{i} & \mathbf{j} & \mathbf{k} \\ A_x & A_y & A_z \\ B_x & B_y & B_z \end{vmatrix} = \mathbf{i}(A_y B_z - A_z B_y)$

For element **j**: $\begin{vmatrix} \mathbf{i} & \mathbf{j} & \mathbf{k} \\ A_x & A_y & A_z \\ B_x & B_y & B_z \end{vmatrix} = -\mathbf{j}(A_x B_z - A_z B_x)$

For element **k**: $\begin{vmatrix} \mathbf{i} & \mathbf{j} & \mathbf{k} \\ A_x & A_y & A_z \\ B_x & B_y & B_z \end{vmatrix} = \mathbf{k}(A_x B_y - A_y B_x)$

Remember the negative sign



MOMENT OF A FORCE – VECTOR FORMULATION (Section 4.3)

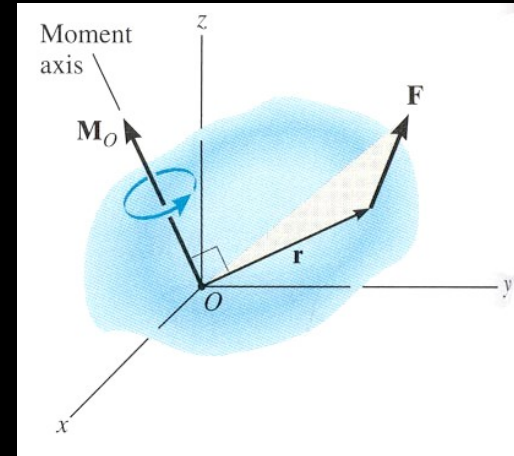
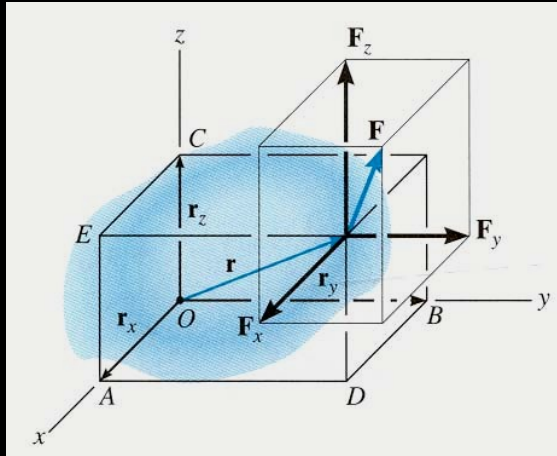

Moments in 3-D can be calculated using scalar (2-D) approach, but it can be difficult and time consuming. Thus, it is often easier to use a mathematical approach called the **vector cross product**.

Using the vector cross product, $M_O = r \times F$.

Here r is the position vector from point O to any point on the line of action of F .



MOMENT OF A FORCE – VECTOR FORMULATION

(continued)

So, using the cross product, a moment can be expressed as

$$\mathbf{M}_O = \mathbf{r} \times \mathbf{F} = \begin{vmatrix} \mathbf{i} & \mathbf{j} & \mathbf{k} \\ r_x & r_y & r_z \\ F_x & F_y & F_z \end{vmatrix}$$

By expanding the above equation using 2×2 determinants (see Section 4.2), we get (sample units are N - m or lb - ft)

$$\mathbf{M}_O = (r_y F_z - r_z F_y) \mathbf{i} - (r_x F_z - r_z F_x) \mathbf{j} + (r_x F_y - r_y F_x) \mathbf{k}$$

The physical meaning of the above equation becomes evident by considering the force components separately and using a 2-D formulation.



EXAMPLE I

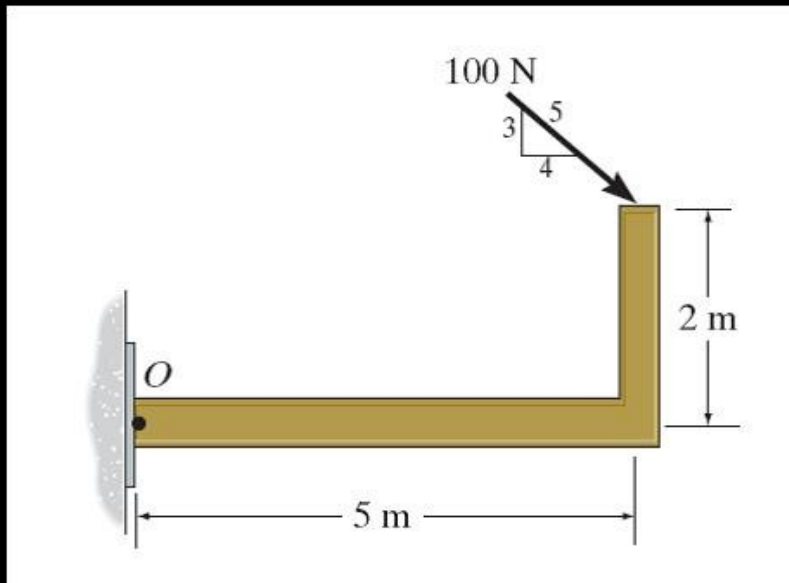

Given: A 100 N force is applied to the frame.

Find: The moment of the force at point O.

Plan:

- 1) Resolve the 100 N force along x and y-axes.
- 2) Determine M_O using a scalar analysis for the two force components and then add those two moments together..



EXAMPLE I (continued)

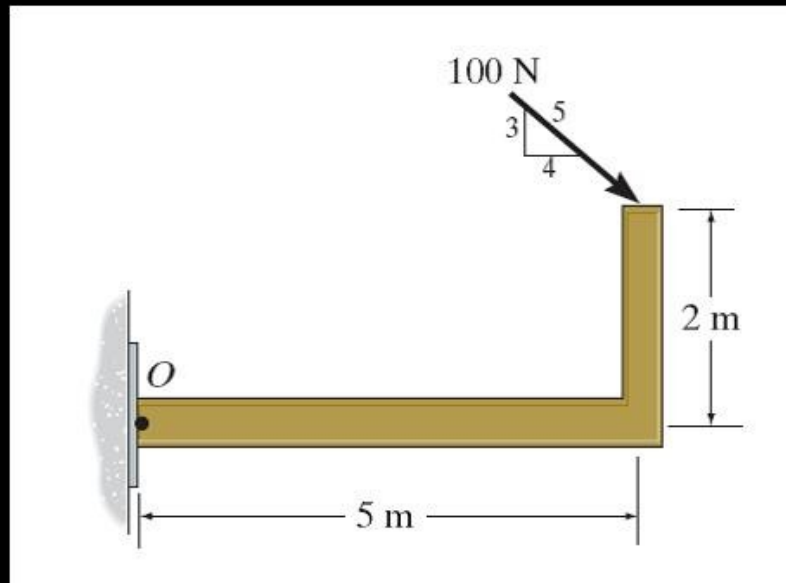

Solution

$$+ \uparrow F_y = -100 \left(\frac{3}{5}\right) \text{ N}$$

$$+ \rightarrow F_x = 100 \left(\frac{4}{5}\right) \text{ N}$$

$$\begin{aligned} + \curvearrowright M_O &= \{-100 \left(\frac{3}{5}\right) \text{ N} (5 \text{ m}) - (100) \left(\frac{4}{5}\right) \text{ N} (2 \text{ m})\} \text{ N}\cdot\text{m} \\ &= -460 \text{ N}\cdot\text{m} \curvearrowright \text{ or } 460 \text{ N}\cdot\text{m CW} \end{aligned}$$



EXAMPLE II

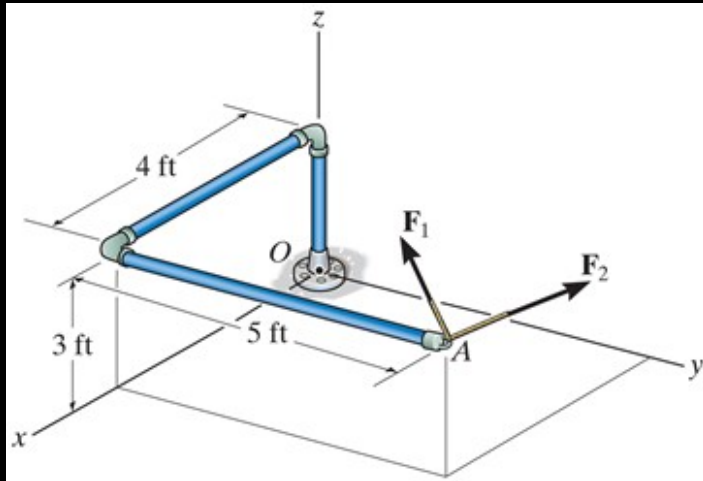

Given: $F_1 = \{100 \mathbf{i} - 120 \mathbf{j} + 75 \mathbf{k}\} \text{ lb}$

$F_2 = \{-200 \mathbf{i} + 250 \mathbf{j} + 100 \mathbf{k}\} \text{ lb}$

Find: Resultant moment by the forces about point O.

Plan:

- 1) Find $F = F_1 + F_2$ and r_{OA} .
- 2) Determine $M_O = r_{OA} \times F$.



EXAMPLE II (continued)

Solution:

First, find the resultant force vector \mathbf{F}

$$\begin{aligned}\mathbf{F} &= \mathbf{F}_1 + \mathbf{F}_2 \\ &= \{ (100 - 200) \mathbf{i} + (-120 + 250) \mathbf{j} + (75 + 100) \mathbf{k} \} \text{ lb} \\ &= \{ -100 \mathbf{i} + 130 \mathbf{j} + 175 \mathbf{k} \} \text{ lb}\end{aligned}$$

Find the position vector \mathbf{r}_{OA}

$$\mathbf{r}_{OA} = \{ 4 \mathbf{i} + 5 \mathbf{j} + 3 \mathbf{k} \} \text{ ft}$$

Then find the moment by using the vector cross product.

$$\begin{aligned}\mathbf{M}_O &= \begin{vmatrix} \mathbf{i} & \mathbf{j} & \mathbf{k} \\ 4 & 5 & 3 \\ -100 & 130 & 175 \end{vmatrix} = [\{ 5(175) - 3(130) \} \mathbf{i} - \{ 4(175) - \\ & \quad 3(-100) \} \mathbf{j} + \{ 4(130) - 5(-100) \} \mathbf{k}] \text{ ft}\cdot\text{lb} \\ &= \{ 485 \mathbf{i} - 1000 \mathbf{j} + 1020 \mathbf{k} \} \text{ ft}\cdot\text{lb}\end{aligned}$$



READING QUIZ

1. What is the moment of the 12 N force about point A (M_A)?

- A) 3 N·m **B) 36 N·m** C) 12 N·m
D) (12/3) N·m E) 7 N·m

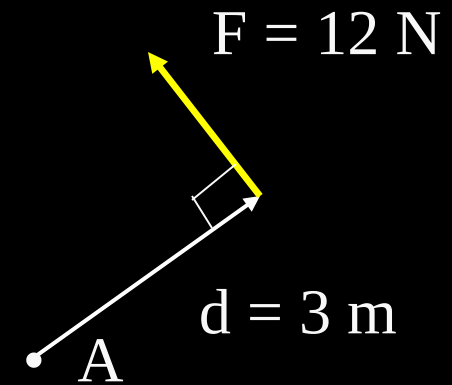

2. The moment of force F about point O is defined as $M_O =$ _____ .

- A) $r \times F$** B) $F \times r$
C) $r \cdot F$ D) $r * F$

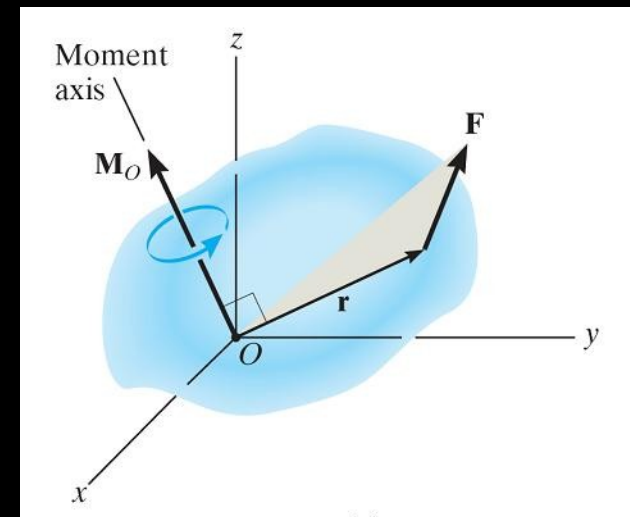

CONCEPT QUIZ

1. If a force of magnitude F can be applied in four different 2-D configurations (P,Q,R, & S), select the cases resulting in the maximum and minimum torque values on the nut. (Max, Min).

A) (Q, P)

B) (R, S)

C) (P, R)

D) (Q, S)

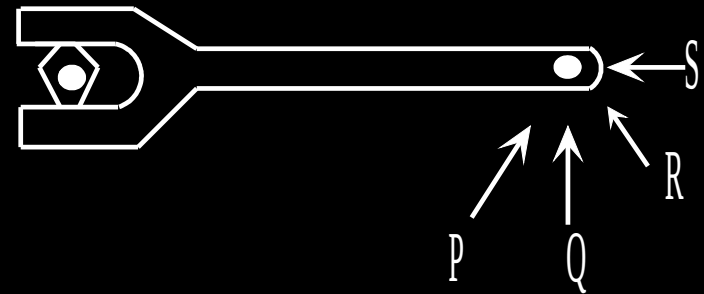

GROUP PROBLEM SOLVING I

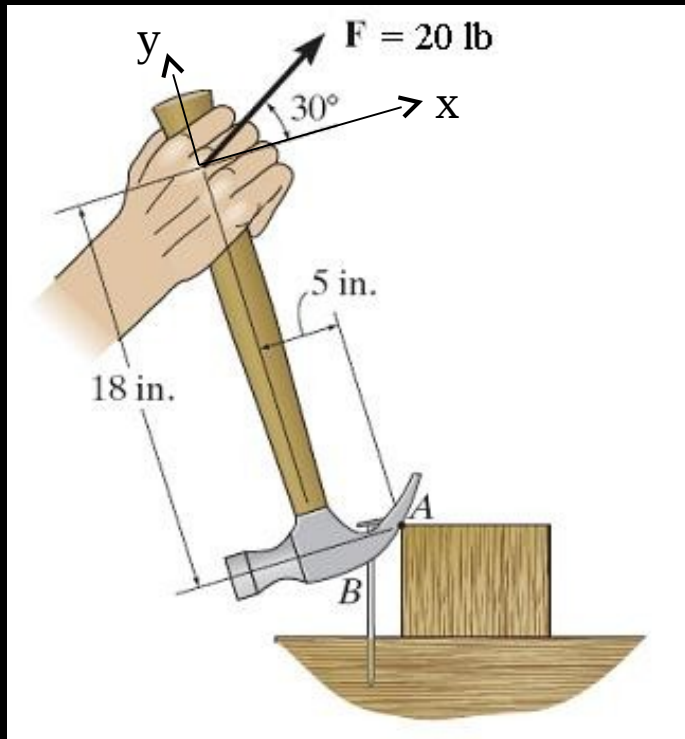

Given: A 20 lb force is applied to the hammer.

Find: The moment of the force at A.

Plan:

Since this is a 2-D problem:

- 1) Resolve the 20 lb force along the handle's x and y axes.
- 2) Determine M_A using a scalar analysis.



GROUP PROBLEM SOLVING I (continued)

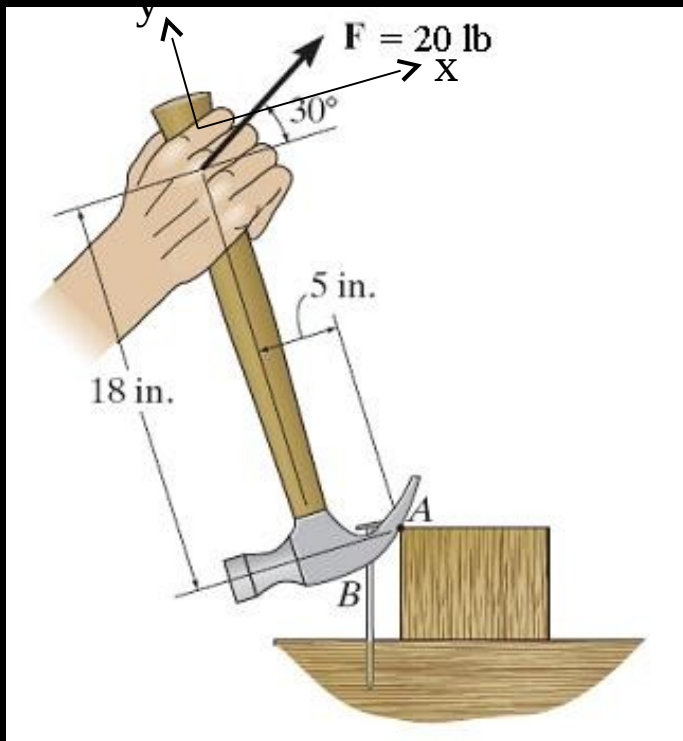

Solution:

$$+ \uparrow F_y = 20 \sin 30^\circ \text{ lb}$$

$$+ \rightarrow F_x = 20 \cos 30^\circ \text{ lb}$$

$$+ \curvearrowright M_A = \{-(20 \cos 30^\circ) \text{ lb} (18 \text{ in}) - (20 \sin 30^\circ) \text{ lb} (5 \text{ in})\}$$

$$= -361.77 \text{ lb}\cdot\text{in} = 362 \text{ lb}\cdot\text{in} \text{ (clockwise or CW)}$$



GROUP PROBLEM SOLVING II

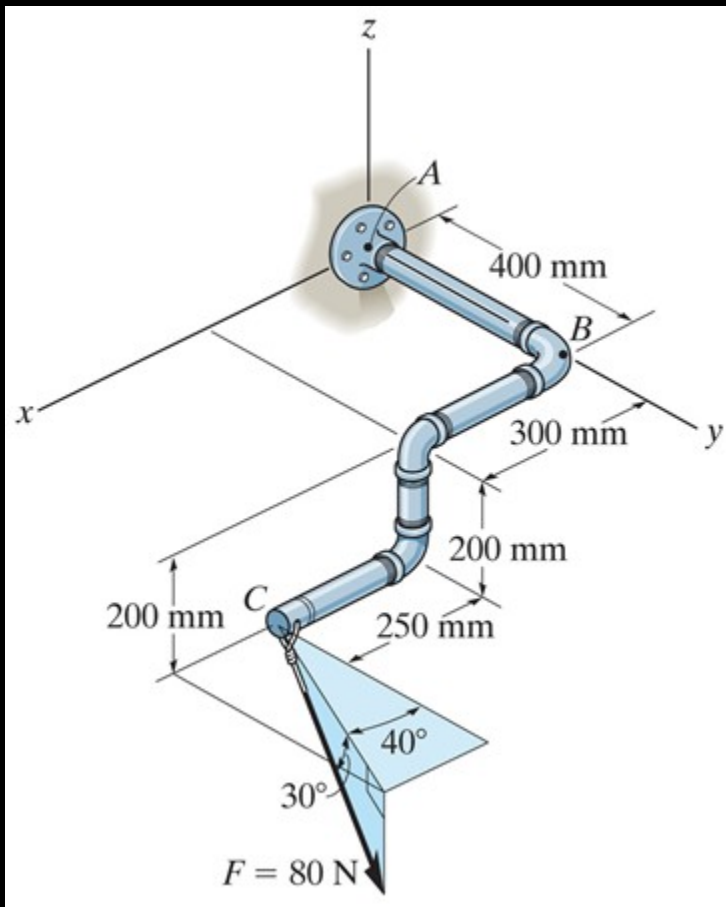

Given: The force and geometry shown.

Find: Moment of F about point A

Plan:

1) Find F and r_{AC} .

2) Determine $M_A = r_{AC} \times F$



GROUP PROBLEM SOLVING II (continued)

Solution:

$$\begin{aligned} \mathbf{F} &= \{ (80 \cos 30) \sin 40 \mathbf{i} \\ &\quad + (80 \cos 30) \cos 40 \mathbf{j} - 80 \sin 30 \mathbf{k} \} \text{ N} \\ &= \{ 44.53 \mathbf{i} + 53.07 \mathbf{j} - 40 \mathbf{k} \} \text{ N} \end{aligned}$$

$$\mathbf{r}_{AC} = \{ 0.55 \mathbf{i} + 0.4 \mathbf{j} - 0.2 \mathbf{k} \} \text{ m}$$

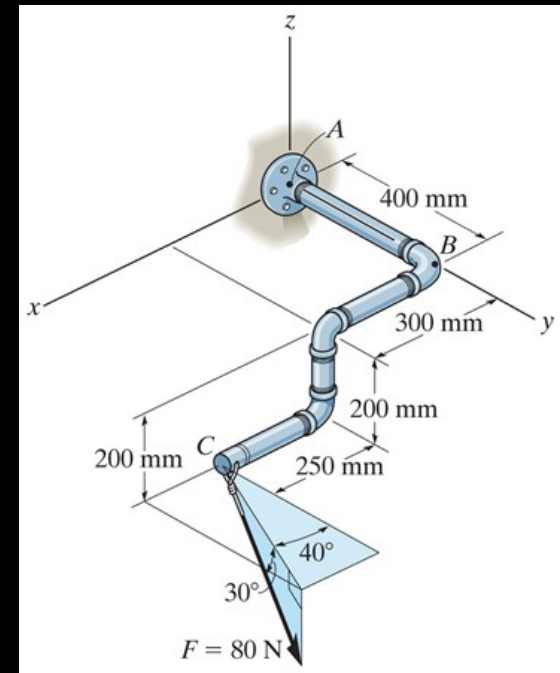

Find the moment by using the cross product.

$$\mathbf{M}_A = \begin{vmatrix} \mathbf{i} & \mathbf{j} & \mathbf{k} \\ 0.55 & 0.4 & -0.2 \\ 44.53 & 53.07 & -40 \end{vmatrix}$$

$$= \{ -5.39 \mathbf{i} + 13.1 \mathbf{j} + 11.4 \mathbf{k} \} \text{ N}\cdot\text{m}$$



ATTENTION QUIZ

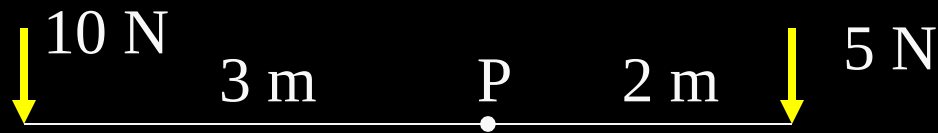

1. Using the CCW direction as positive, the net moment of the two forces about point P is

- A) 10 N · m **B) 20 N · m** C) - 20 N · m
D) 40 N · m E) - 40 N · m

2. If $\mathbf{r} = \{ 5 \mathbf{j} \}$ m and $\mathbf{F} = \{ 10 \mathbf{k} \}$ N, the moment

$\mathbf{r} \times \mathbf{F}$ equals $\{ \underline{\hspace{2cm}} \}$ N·m.

- A) 50 i** B) 50 j C) -50 i
D) - 50 j E) 0

