

AUBERT&DUVAL



high performance steels  
aluminum  
titanium  
superalloys



Sustainable solutions  
for Aerospace  
high integrity  
components

Enhancing your performance

# Aubert & Duval integrated from nose to tail

## Process flow

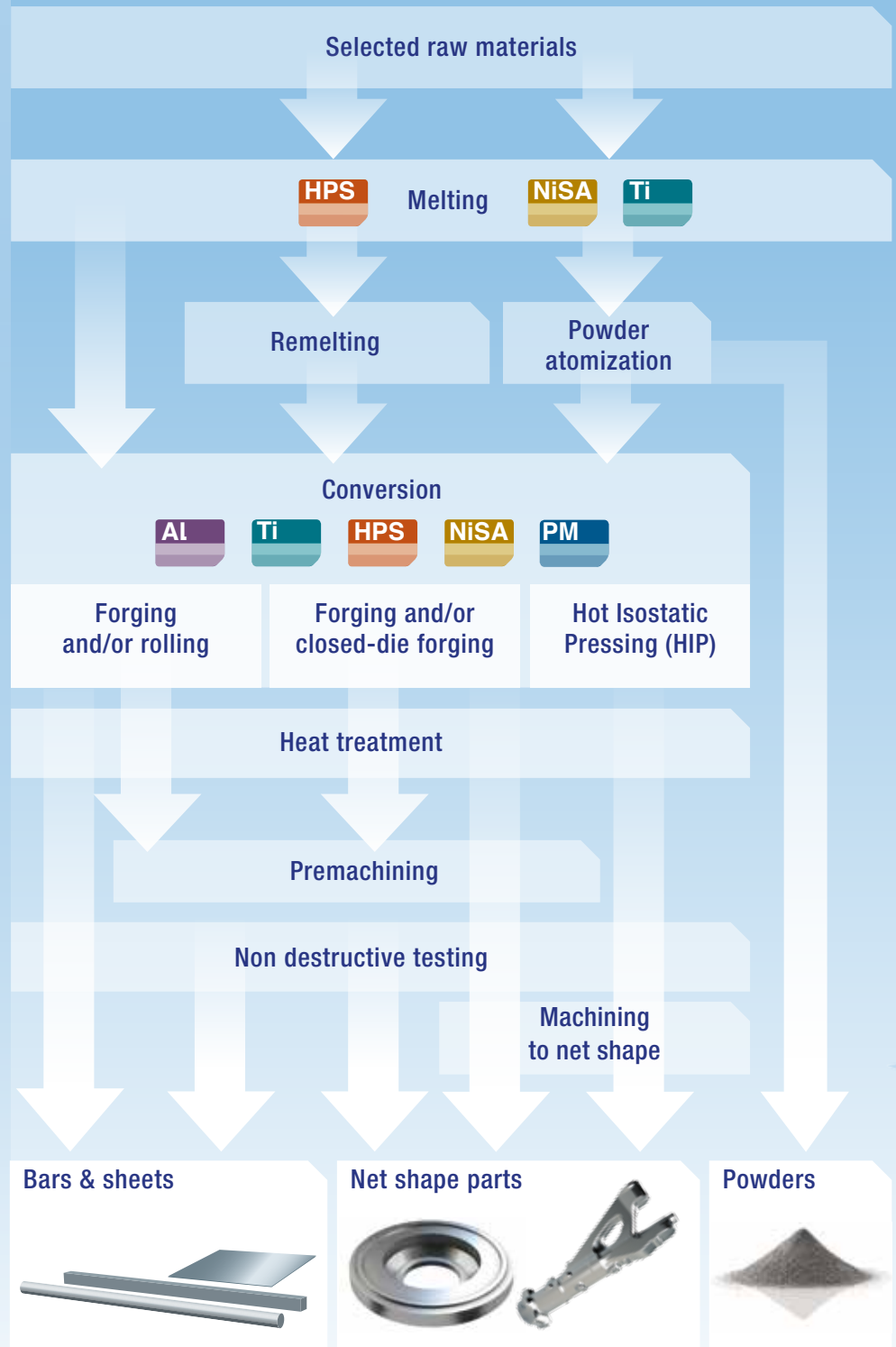

### HPS

#### High-Performance Steels:

A range of alloyed steels with tightly controlled characteristics offering optimum value for customers.

### NiSA

#### Nickel-based Superalloys:

A range of alloyed materials with specific resistance to very high temperatures and corrosion, the majority component being nickel.

### Ti

#### Titanium:

Pure or alloyed titanium, combining mechanical properties and corrosion-resistance with light weight.

### Al

#### Aluminum:

Slightly alloyed aluminum, widely used in aircraft structural parts.

### PM

#### Powder metallurgy:

HIP Net Shape parts & Metal Powders (steels, superalloys or titanium) for additive manufacturing.

**F**ounded in 1907, shortly after the first manned flight, Aubert & Duval has continuously participated in the development of the most challenging programs. Today, we partner with OEMs for the development of their newest programs: A350 XWB, A400M, A320neo, Boeing 787, 737 MAX, C 919, Superjet 100, CSeries...



## Aubert & Duval, the global solution

While earlier aircraft were based on a wooden frame, both aluminum and steel have been extensively used for fuselage and wings, further complemented by composites and titanium.

In the same time, engines have also evolved, to withstand higher and higher combustion temperatures, now reaching 800°C / 1,475°F. Hence the development of Nickel-based alloys to meet these stringent requirements. In modern aircraft, Aubert & Duval offering encompasses 90% of potential metallic applications. This is achieved since we process in-house the 4 most critical materials: High-Performance Steels, Nickel, Aluminum and Titanium.

We also master the full range of melting and remelting processes: EAF, VIM, ESR, VAR and gas atomization. We use the most sophisticated open-die and closed-die forging techniques. We forge and roll bars and sheets in all kinds of alloyed steels, Nickel-alloys and Titanium-alloys.

Average split of metallic materials in civil aircraft

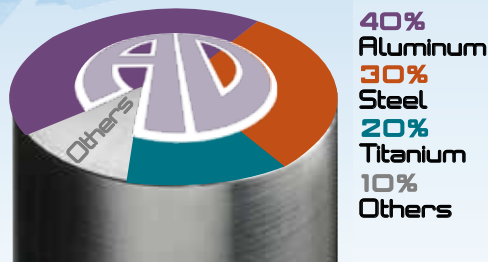

## Contents

Aircraft	4 - 9
Structures	4 - 5
Landing gear	6 - 7
Engines	8 - 9
Helicopters	10 - 11
Bars	12 - 13
Powder Metallurgy	14 - 15
Challenges	16 - 17
Future	18 - 19

For information on the space industry please refer to the dedicated brochure. You can download it on our website.

# Providing resistance at key locations

## Body bulkhead frames

Al  
FORGINGS

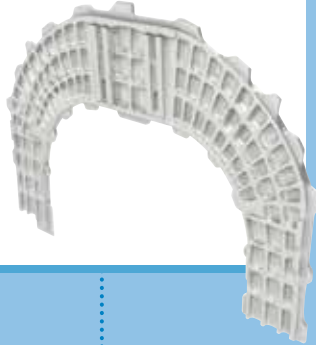

## Slat tracks

HPS  
FORGINGS  
BARS



## THSA

HPS  
FORGINGS  
BARS



## Engine pylon parts

HPS  
FORGINGS

At Aubert & Duval, we manufacture most of the parts for engine pylons such as spars and beams.

Ti  
FORGINGS

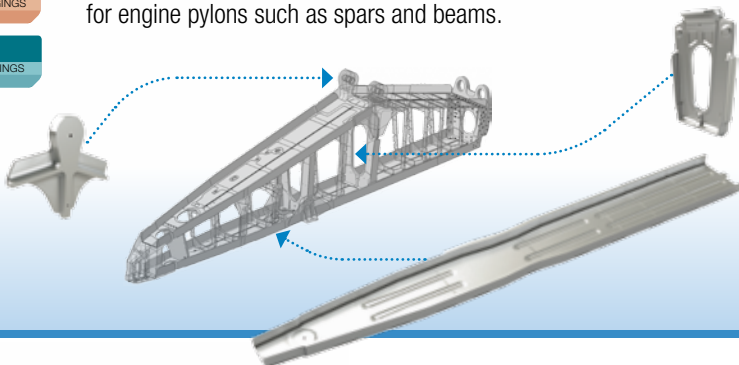

## Nacelle parts

Al  
FORGINGS

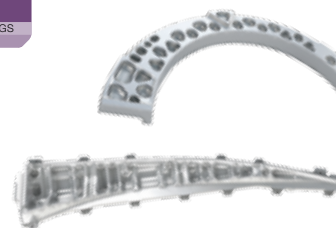

**A** bird is not only made of feathers! It is built on a relatively resistant, albeit supple assembly of bones and articulations which altogether connect and animate the whole body. A similar role is played by our critical parts, providing maximum safety with minimum surcharge. So, when the 'bird' is 80 m / 262 ft long and weighs 600 t, Aubert & Duval is *the* metallurgy specialist to partner with.

## Door frames

Ti  
FORGINGS

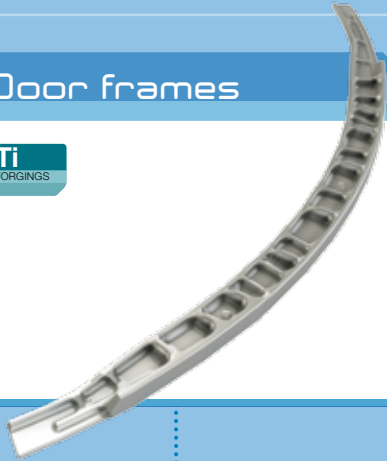

## The largest closed-die forging press in the Western World



### ■ A powerful press...

- 65 KT capacity
- Weighing twice the Eiffel Tower

### ■ ... with a high degree of precision:

- Speed control to the mm per second
- Centering to the mm

## Main materials

High performance steels

### HPS

A&D grade	Common name
MARVALX12	AMS 5928
MARVALX12H	AMS 5935
MARVAL13X	PH13-8Mo
MLX17 <b>New</b>	AMS 5937
MLX19 <b>New</b>	AMS 5955
CX13VDW	AMS 5719
X15U5W	15-5PH
X17U4	17-4PH
819AW	E35NCD16H
819B	35NCD16
FDMA	30NiCrMo16
MARVAL18	Maraging 250
MY19	Maraging 300
NC40MW	4330
NC40SW	300M
NC310YW	AMS 6499

Aluminum Alloys

### Al

7175  
7010  
7050  
Airware 2050 (Al-Cu-Li) **New**  
2214  
2219  
2618  
6061

Titanium Alloys

### Ti

TA6V  
Ti555.3  
Ti17  
Ti10.2.3  
Ti6.2.4.2

## Wing mount parts

Al  
FORGINGS

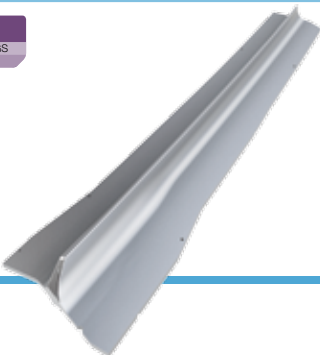

## Wing box parts

Al  
FORGINGS

Ti  
FORGINGS



## Main data

### Closed-die forging parts:

- From 50 kgs / 110 lbs to 20 t
- Up to 8 m / 314 in

# Utmost confidence for repeated landings

Main  
landing  
gear

## Arms

Al  
FORGINGS

HPS  
FORGINGS

Ti  
FORGINGS



## Bogie beams

HPS  
FORGINGS

Ti  
FORGINGS



## Brake rods

HPS  
BARS



## Large and smaller round bars used in landing



We provide various types of semi-finished products for hydraulic and electric actuators, braking pads and related fittings. Namely for landing gear locking, retraction and steering, or braking torque systems.

**A**lways trying to land as softly as birds, aircraft are built to withstand exceptional situations such as wind gusts where the impact pressure can be compared to a car crashing at 160 km/h - 100 mph, this without getting damaged, and still with only 2 main landing gear. The largest part now reaches 3.5 m / 118 in, twice the size of a human being. Material choice and quality are therefore of utmost importance to meet these requirements. With the understanding that, every second, a large passenger aircraft lands somewhere in the world.

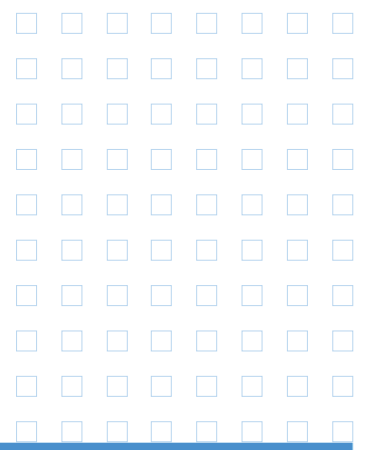

## Nose landing gear

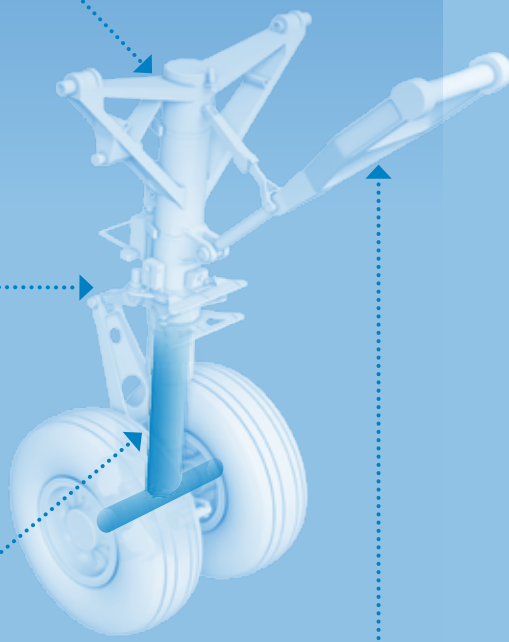

### Main fittings

HPS FORGINGS

Al FORGINGS



### Torque links

Al FORGINGS

Ti FORGINGS



### Sliding tubes

HPS FORGINGS

Al FORGINGS

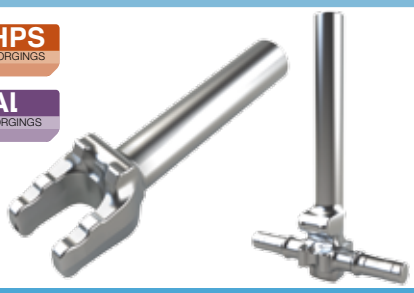

### Panels

Al FORGINGS



### Main materials

Titanium Alloys

**Ti**

TAGV  
Ti662  
Ti10.2.3

Aluminum Alloys

**Al**

7010  
7175

High performance steels

**HPS**

A&D grade	Common name
NC40SW	300M
819AW	E35NCD16H
819B	35NCD16
FADHW	16NiCrMo13
GKHYW	AMS 6481
MLX17 <i>New</i>	AMS 5937
MLX19 <i>New</i>	AMS 5955
MARVAL13X	PH13-8Mo
NC40MW	4330
X15U5W	15-5PH

### Main data

#### Closed-die forging parts:

- From 50 kg / 110 lbs to 20 t
- Up to 8 m / 314 in



# Meeting the most arduous requirements

## LPC/IPC disks

**Ti**  
FORGINGS



## HPC disks

**NiSA**  
FORGINGS

**PM**  
HIP PARTS

**Ti**  
FORGINGS



## Compressor shafts

**HPS**  
FORGINGS  
BARS

**Ti**  
FORGINGS



## Spinners

**Al**  
FORGINGS



## Fan disks

**Ti**  
FORGINGS



## Turbine shafts

**HPS**  
FORGINGS  
BARS

**NiSA**  
FORGINGS  
BARS

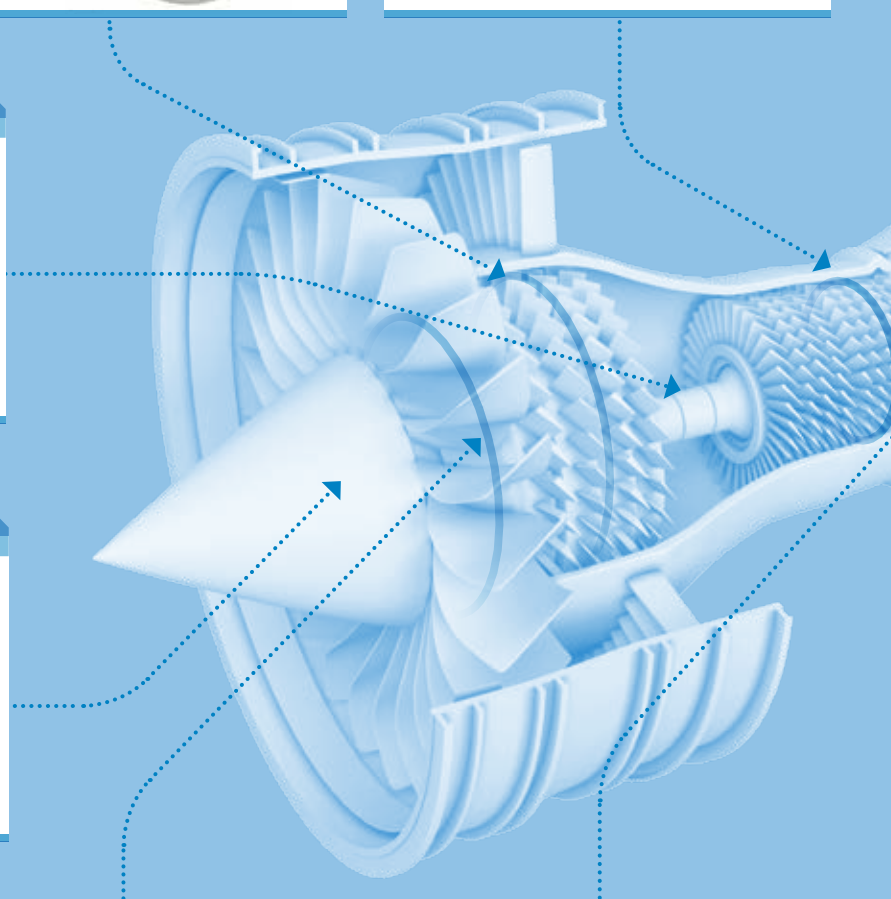



**N**o parts in the engine face as many stress challenges as rotating parts: temperatures close to 800°C / 1,475°F, corrosion from gas and humidity, resistance to shock and crack propagation, to name a few. And this for hours and hours... with minimized fuel consumption. Hence the necessity for the most advanced materials such as Nickel-based Superalloys and Titanium, and for the most demanding techniques such as open and closed-die forging.

## Cone shafts

NiSA  
FORGINGS

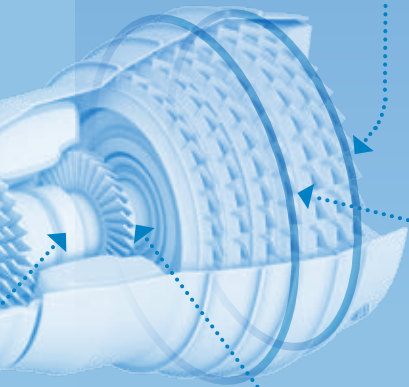

- The 40 KT closed-die forging press is the center piece of our fully-automated EDPL (Engine Disk Production Line).
- Lean workshop integrating all steps from the preparation of our own billets to final ultrasonic tests.

## LPT disks

NiSA  
FORGINGS



## HPT disks

NiSA  
FORGINGS

PM  
HIP PARTS



## Main materials

High performance steels

### HPS

A&D grade	Common name
GH4W	40CrMoV12
MARVAL 18	Maraging 250
ML1014	GE1014
ML340 <i>New</i>	X23NiCoCrMoAl13-6-3
X17U4	17-4PH
X13VDW	X12CrNiMoV12
XN26TW	A286

Superalloys

### NiSA

A&D grade	Common name
PER718	INCO 718
PER72	Udimet720
PER3	Waspaloy
-	Gatorized Waspaloy
PER901	INCO 901
AD730 <i>New</i>	-

Aluminum Alloys

### Al

2618  
7050

Titanium Alloys

### Ti

TA6V  
Ti6.2.4.6  
Ti17  
Ti6.2.4.2

Powder metallurgy

### PM

**Powder metallurgy:**  
Gas-atomized alloyed steels, superalloys, or titanium powders, further hipped into semi-finished or near net-shaped products.

## Main data

### Closed-die forging parts:

- From 20 kgs / 44 lbs to 20 t
- **Max diameter for disks:** 1,400 mm / 55 in
- **Max length for shafts:** 4 m / 157 in

# Safety, flexibility and speed

## When incompatible becomes feasible

Helicopters must endure a very high torque effect in the main gear box, as well as many vibrations.

At the same time, to avoid fatigue, the same parts must offer very high hardness characteristics. This is made possible with Aubert & Duval nitriding or carburizing proprietary grades such as GKP, FND and FDG which allow to combine flexible core and hard surface.

## Engine parts

HPS  
FORGINGS  
BARS

Ti  
FORGINGS

NiSA  
FORGINGS  
BARS

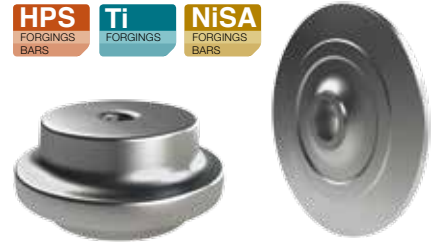

## Transmission box parts

Al  
FORGINGS

HPS  
FORGINGS  
BARS



## Main fitting

Al  
FORGINGS

Ti  
FORGINGS



# Over the decades, helicopters have become an irreplaceable transportation means.

Not only for traditional military, offshore or business requirements, but more and more for police, anti-terrorism, border protection, health care and other emergency issues. For the next decade, it is predicted that approximately 16,000 turbine helicopters will be needed, the vast majority consisting of new rotorcraft for fast growing countries such as China.

## High Performance Steel Bars



Available in small or larger diameters and cut-to-size, these bars are machined, then used in the main rotor, 42- and 90-degree transmission systems, main frame, and other demanding applications.

## Rotor parts

**Ti**  
FORGINGS

**HPS**  
FORGINGS  
BARS

**Al**  
FORGINGS



## Main materials

High performance steels

### HPS

A&D grade	Common name
819AW	E35NCD16H
CX13VDW	AMS 5719
FDG	AMS 6493
FND	AMS 6495
GKHYW	AMS 6481
GKPYW	AMS 6497 - 6498
MARVALX12	AMS 5928
MLX17 <i>New</i>	AMS 5937
MLX19 <i>New</i>	AMS 5955
X15U5W	15-5PH
X17U4	17-4PH

Aluminum Alloys

### Al

7175  
Airware 2050 (Al-Cu-Li) *New*

Superalloys

### NiSA

A&D grade	Common name
AD730 <i>New</i>	-
PER72	Udimet720

Titanium Alloys

### Ti

Ti10.2.3  
TA6V

## Main data

### Closed-die forging parts:

- From 50 kgs / 110 lbs to 20 t
- Up to 8 m / 314 in

### Max diameter for disks:

1,200 mm / 47 in

# Setting the bars at their highest

## Titanium bars

Through its UKAD 4,500-ton forging press, Aubert & Duval has made the first step towards the manufacturing and sales of bars made of commercially pure and alloyed titanium.

Our customers transform our bars

## Rods, rod-ends and struts

These are generally fabricated out of round bars, and potentially used all across the aircraft or helicopter.

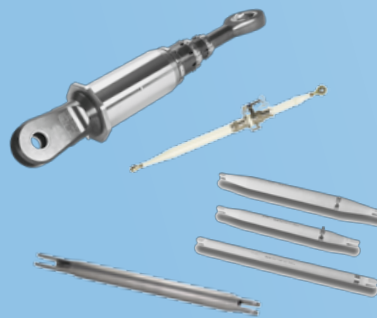

## Structural fasteners and assembly components

Round bars or wire for bolts, nuts, studs, pins, clamps, hinges, all kinds of fittings, and other safety parts.



## Gears and shafts

While shafts are essential parts of aircraft engines, 42- and 90-degree transmissions are key to helicopters integrity. Other gears and shafts can be found in several other devices: APU, wing flaps, landing gear, pumps, etc.



## Bearings and ball screws

Ball bearings, roller bearings, flange bearings are used in numerous areas, such as engines and hydraulic or electric actuators.



## Main sizes

	mm	inches
Round Bars	Ø 7.5-500	Ø 0.30-20
Flat & Square Bars	T ≤ 310	T ≤ 12
Sheets	0.6 ≤ T ≤ 150	0.2 ≤ T ≤ 6

## Surface conditions

- Black
- Peeled
- Ground
- Others

## Heat treatment conditions

- Annealed
- Hyperquenched
- Normalized
- Heat solution treated
- Heat treated
- Aged

**Whether used in transmission, in engines or as fittings**, the millions of small parts play a role as important as that of larger parts. They are generally machined from bars which can be forged, rolled or drawn. The initial quality of the selected materials is therefore key to the overall performance and safety of the aircraft. This is why our bars – round or flat – billets and sheets are designed, manufactured and tested with the same rigorous care as larger parts.

The material you need, where you need it

Offering state-of-the-art products would be of no use if not supported by a first-class logistics service. Aubert & Duval is constantly adapting its service offer to meet changing logistical requirements.

We are therefore able to deliver medium or small-size orders on a regular basis for call-off supplies, or rapidly when it comes to emergency shortages.

## Certifications and specifications

In addition to general certifications (ISO 9001, ISO 14001, ISO 18001), our Lyon Service Center is certified to the most stringent industry specific standards: ISO 9100 (aero design and manufacturing), ISO 9120 (aero distribution) and AQAP 2110 (NATO). Also, our products are AMS, ABS and ASNA specified.

For more information on bars, please refer to our dedicated brochures. You can download them on our website



### Main materials

High performance steels

HPS	
A&D grade	Common name
819B	35NiCrMo16
FADC	9310
FADHW	16NiCrMo13
FDG	AMS 6493
GH4	40CrMoV12
GKHYW	AMS 6481
GKPYW	AMS 6497 - 6498
MARVAL18	MARAGING 250
NC310YW	AMS 6499
NC40SW	300M
RA50YW	M50
SCV	15CDV6
APX	431
CX13VDW	AMS 5719
MARVAL13X	PH13-8Mo
MLX17 <i>New</i>	AMS 5937
MLX19 <i>New</i>	AMS 5955
X13VD	JETHETE M152
X15U5W	15-5PH
X17U4	17-4PH
XD15NW	AMS 5925
XDBD	440C
XN26TW	A286

STEELS

STAINLESS STEELS

Superalloys

NiSA	
A&D grade	Common name
PER3	Waspaloy
PER75	NIMONIC 75
PER625	INCO 625
PER718	INCO 718
XSH	KC20WN

Titanium Alloys

Ti	
TA6V	
Ti555.3	
Ti17	
Ti10.2.3	
Ti6.2.4.2	
Ti662	
TA6VEli	

# Optimize your buy-to-fly ratio with powder metallurgy

## Net Shape parts by Hot Isostatic Pressing (HIP)

Aubert & Duval has a unique capability in the design and manufacturing of medium to large metal parts, from simple to complex design, thanks to Hot Isostatic Pressing technology.

Hot Isostatic Pressing (HIP) is a process to densify powders in a HIP furnace

- at high pressure (usually 100, up to 200 MPa)
- and high temperature (usually from 900 to 1250°C).

The gas pressure acts uniformly in all directions to provide isostatic properties and 100% densification.

### HIP process steps



Net Shape container assembly & welding

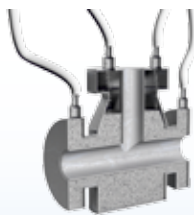

Container filling with metal powder



Powder densification by Hot Isostatic Pressing



Fully dense finished part

### HIP semi-products

PM  
HIP PARTS



### HIP Net Shape impeller

PM  
HIP PARTS

For space rocket



Courtesy of  
Safran Aero Engines

### HIP Net Shape Casings

PM  
HIP PARTS

For aircraft and helicopter engines



Courtesy of  
Safran Aero Engines

**A**ubert & Duval and its sister company Erasteel, offer a unique portfolio of technologies in the field of powder metallurgy (PM).

Hot Isostatic Pressing (HIP) and additive manufacturing are innovative technologies to produce complex metal Net Shape parts in small to medium series with key benefits:

- material savings, thanks to the net shape design possibilities
- less machining and fewer welding & assembly operations
- shorter manufacturing leadtime vs conventional metallurgy

## Powder manufacturing process VIM gas atomization

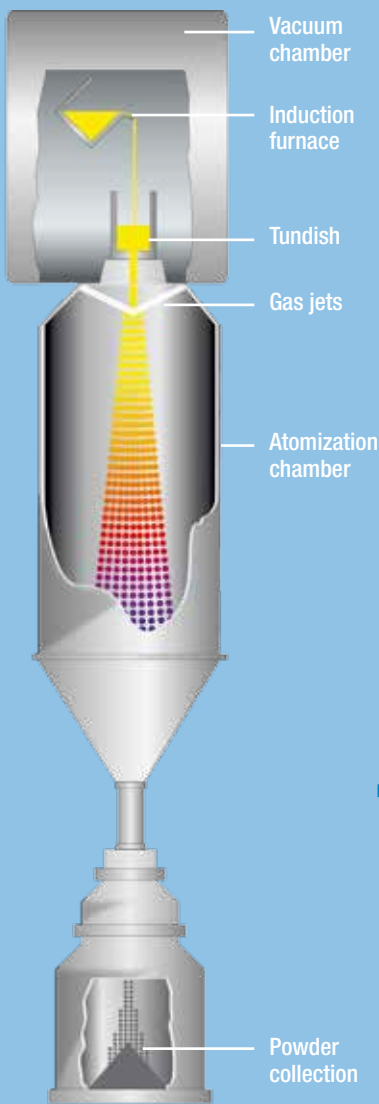

## Powders for additive manufacturing

Aubert & Duval and Erasteel is the world leading producer of spherical gas-atomized powders for Hot Isostatic Pressing, Additive Manufacturing and MIM. Available in tailor made compositions, particle size distribution and small batches, Pearl® Micro powders are recommended for various additive manufacturing technologies (SLM, EBM, 3D printing, laser metal deposition). Aubert & Duval state-of-the-art VIM gas atomization process is recommended for alloys with reactive elements and to ensure low gas content.

### Additive manufacturing process steps



A thin layer of powder is applied on the powderbed



A laser beam selectively the powder layer



The operation is repeated until the part is built



Finished net shape part

### Pearl® Micro metal powders for additive manufacturing



### PM

#### HIP parts and Additive Manufacturing

<b>Ni-Base</b>	Ni 625, Ni 718, 247LC, 738LC
<b>Co-Base</b>	CoCr
<b>Ti-Base</b>	Ti6Al4V, Ti6Al4V ELI
<b>Steels</b>	316L, 17-4PH, ASP®, etc...

# Meeting our customers ever more demanding requirements

We make  
sure we deliver  
the best product

Components and parts we produce at Aubert & Duval are critical and have to comply with the most stringent specifications. Therefore, our products go through advanced non-destructive tests:

- Magnetic particle inspection
- Fluorescent penetrant testing
- Red dye penetrant testing
- Eddy current testing
- Ultrasonic testing (including phased array)
- Radiographic testing

Many NDT are performed at different steps in the metallurgical process, from melting to the delivered parts. Aubert & Duval is accredited by COFREND to perform certification examination for level 1 and 2 in accordance with COSAC (EN 4179) and CCPA (EN473).



More reliable

Customer

Cleaner and safer



A

ubert & Duval contributes to the global sustainability challenge.

We work exclusively on fully and easily recyclable materials. By developing enhanced materials solutions, we allow our customers to build ever more fuel-saving aircraft. In addition, our production and warehousing sites are ISO 14001 certified.

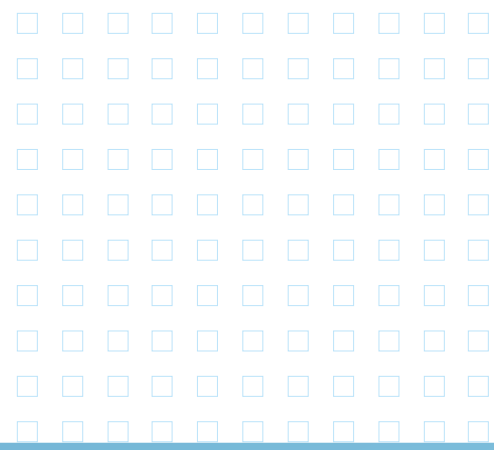

## Fully integrated tier 1 supplier

In fine metallurgy, each process step strongly depends on how the upstream ones have been carried out. In the past, a single person would master the whole chain from raw material selection to end-testing, thus ensuring the customer with an optimized flow. Today, thanks to its integration scheme, Aubert & Duval can provide the same kind of benefits, with the volumes, speed and quality corresponding to most modern requirements. We are today able to manage the full chain from raw materials to machining.

## Improved performance

## Sustainability

All our handled materials are systematically recycled. This is particularly necessary while only a part of the weight bought will actually fly. We contribute directly to environmental protection through the development of ever more effective materials. These combine several of the following features:

- Resistance to high-temperature, allowing the highest-yield engines.
- Lower density, to lighten the aircraft weight, hence also decrease fuel consumption.
- High intrinsic mechanical resistance, in order to use less materials.
- Surface immediately resistant to corrosion, to avoid hazardous chemical coatings.



# We invest in new solutions

## New materials

**HPS**

### ML340

This duplex hardening grade is specifically adapted for turbine shafts operating at high temperature (450°C/840°F), and requiring 2230 MPa/323 Ksi resistance. This allows savings in weight, together with engine efficiency improvement, hence lower gas consumption.



**HPS**

### MLX<sup>®</sup>17 & MLX<sup>®</sup>19

These new precipitation hardening steels show a strength of 1700/1900 MPa (247/276 Ksi), and simultaneously keep an excellent resistance to stress-corrosion cracking. Eliminating the need for cadmium plating, it is a most environmentally friendly solution.

**NiSA**

### AD730<sup>®</sup>

Designed to improve engine efficiency and save fuel, AD730 is a fully-innovative nickel-based superalloy. It withstands higher temperatures (700°C/1,350°F) while preserving strength, creep and fatigue resistance at a competitive cost.

**Al**

### Aluminum-lithium alloys

Aluminum lithium grades (such as Airware<sup>®</sup> 2050) allow weight gain up to 4%. Their static properties are equivalent or higher than 7010/7050 and fatigue and rigidity properties improved more than 10%.

Our R&D expenditure represents

**4%**

of our added economic value

**B**ased on its own proprietary work as well as on cooperation with customers or other partners, Aubert & Duval continuously develops new processes and new products, able to face technical and economical challenges. In investment, priority has been recently given to capacity extension, so as to be fully ready for the rapid development of the aerospace industry.

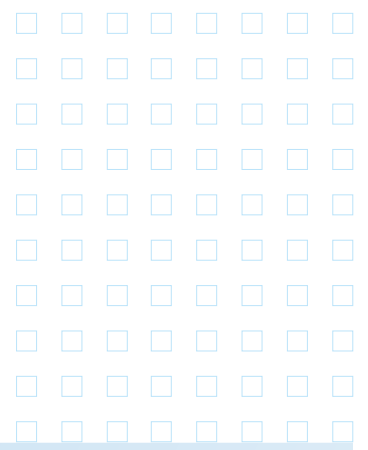

## A unique range of facilities

### Ti Integrated solution for titanium

With its fully integrated solution for titanium, Aubert & Duval is a leading global supplier and manufacturer of aviation grade titanium and titanium alloy products. From melting to finished parts, Aubert & Duval produces high strength titanium alloy products in ingots, billets, closed die-forging and machined parts.

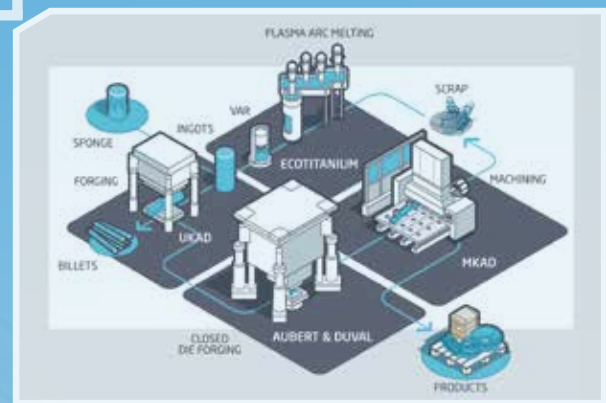

### PM Powder metallurgy

Aubert & Duval, and its sister company Erasteel, are key players in innovative and promising technologies such as Hot Isostatic Pressing and Additive Manufacturing.

The whole group operates atomization units, and in particular facilities:

- in Irun (Spain), on Aubert & Duval site, which operates in particular a state-of-the art VIM gas atomizer, for additive manufacturing, MIM and R&D.
- in Söderfors (Sweden), with the new Durin large capacity gas atomization tower, in operation since 2011: dedicated to the production of high quality steels.

With these facilities and a unique know-how in metallurgy and metal powders, Eramet Alloys can help its aerospace partners to develop new solutions based on net shape technologies.

### NiSA VIM furnace for larger ingots

Aubert & Duval has recently extended its vacuum melting capacity by investing in a VIDP (Vacuum Induction Degassing & Pouring) furnace. This cutting-edge facility allows the casting of ingots up to 20 t.



### HPS AL Ti NiSA

#### Precision forging integrated solution in India

SQuAD Forging Private Ltd. (JV with Aequus) is dedicated to the production of small to medium-size closed-die forging components for demanding applications (Aerospace, Space, Defense...). Strong of its forging capacity up to 10,000 t hydraulic press together with heat treatment dedicated lines, SQuAD is the preferred partner to provide vertically integrated solutions from forging to finished parts.

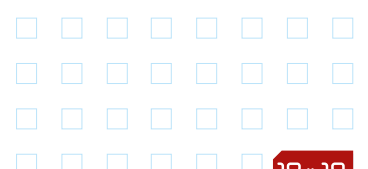

# AUBERT & DUVAL



“Our ambition is to be, for our customers,  
a worldwide metallurgy reference,  
innovative, agile and aware of our responsibilities.”



[www.aubertduval.com](http://www.aubertduval.com)

AD730, GKH, MARVAL, MLX, X13, X15NW  
are trademarks owned by Aubert & Duval  
ASP, Pearl are trademarks owned by Erasteel  
Airware is a trademark owned by Constellium

Design by [makheia](#) & [affinity](#) - Aubert & Duval - 06-2017

Photo credits: A. Chassin, Airbus, Fotolia,  
R. Seaman, SKF, THSA - Ratier Figearc

Printed in France - PEFC 10-31-1592

The information and the data presented herein are typical or average values and are not a guarantee of maximum or minimum values. Applications specifically suggested for material described herein are made solely for the purpose of illustration to enable the reader to make his own evaluation and are not intended as warranties, either express or implied, of fitness for these or other purposes. Aubert & Duval 's liability shall not extend, under any circumstances, to the choice of the Product and its consequences.

a member of

**ERAMET**

