

Installation and Operations Manual

Envoy™ Communications Gateway





Contact Information

Enphase Energy Inc.
201 1st Street
Petaluma, CA 94952
Phone: 707-763-4784 TOLL FREE: 877-797-4743
Fax: 707-763-0784

<http://www.enphase.com>

info@enphaseenergy.com

FCC Compliance

This equipment has been tested and found to comply with the limits for a Class B digital device, pursuant to part 15 of the FCC Rules. These limits are designed to provide reasonable protection against harmful interference in a residential installation. This equipment generates, uses and can radiate radio frequency energy and, if not installed and used in accordance with the instructions, may cause harmful interference to radio communications. However, there is no guarantee that interference will not occur in a particular installation. If this equipment does cause harmful interference to radio or television reception, which can be determined by turning the equipment off and on, you are encouraged to try to correct the interference by one or more of the following measures:

- Reorient or relocate the receiving antenna.
- Increase the separation between the equipment and the receiver.
- Connect the equipment into an outlet on a circuit different from that to which the receiver is connected.
- Consult the dealer or an experienced radio/TV technician for help.

Changes or modifications not expressly approved by the party responsible for compliance may void the user's authority to operate the equipment.

Other Information

For third-party license information, refer to www.enphase.com/licenses.

Product information is subject to change without notice. All trademarks are recognized as the property of their respective owners.

For Enphase Envoy Warranty Terms and Conditions, see the Appendix on page 49 of this manual.

Copyright © 2011 Enphase Energy. All rights reserved.





Table of Contents

Important Safety Information	6
Read this First	6
Safety Instructions.....	6
The Enphase Envoy Communications Gateway	7
Other Elements in the Enphase System	8
How the Envoy Communications Gateway Works	8
Envoy Installation	9
Preparation	9
Installation Flow	9
Install the Envoy.....	10
1. Add Serial Number Label to Map	10
2. Register the Envoy.....	10
3. Find a Location for the Envoy	11
4. Connect Ethernet and Power Cables	11
5. Connect Power Line Communication Bridges (Optional)	12
6. Check the Envoy's Progress.....	12
7. Wall Mount the Envoy (Optional)	13
8. Build the Virtual Array	13
9. View System Performance in Enlighten	14
Envoy Operation	15
Initial Screen Displays	15
First Scan for Microinverters.....	16
Normal Operation	16
Using The Envoy LCD Menu	17
Performing a Communication Check.....	19
Initiating a Scan for New Microinverters	20
Viewing the Grid Configuration	21
Enabling a Connection to Enphase	23
Disabling a Connection to Enphase.....	23
Selecting a New Locale (Change Language Display)	23
How the Envoy Works with Enlighten.....	24
Networking and Firewall Info.....	25
Using Enlighten to Check Envoy Status.....	25
Troubleshooting	26
Power Line Communication Troubleshooting	26
Local Area Networking Troubleshooting	27
Envoy Local Interface	28
Home Screen	29
Production Screen	29
Inventory Screen	30
Administration Screen	30
Administration Screen Tasks	31
Manage the Grid Profile	31
Clear GFI Tripped Condition	37
Device Scan Control.....	38
Set the Time Zone	40
Event Messages	41
Technical Data	48
Appendix A.....	49
Limited Warranty	49

Important Safety Information

Read this First

- **Follow the instructions in this manual. These instructions are key to the installation and maintenance of the Enphase Envoy Communications Gateway (Envoy™).**
- **To ensure the safe installation and operation of the Envoy, note the following safety symbols that appear throughout this document to indicate dangerous conditions and important safety instructions.**



WARNING! This indicates a situation where failure to follow instructions may be a safety hazard or cause equipment malfunction. Use extreme caution and follow instructions carefully.



NOTE: This indicates information particularly important for optimal system operation. Follow instructions closely.

Safety Instructions

- Perform all electrical installations in accordance with all local electrical codes and the National Electrical Code (NEC), ANSI/NFPA 70.
- Do not attempt to repair the Envoy; it contains no user-serviceable parts. If the Enphase Envoy fails, please return the unit to your distributor for maintenance. Tampering with or opening the Envoy will void the warranty.
- Before installing or using the Envoy, please read all instructions and cautionary markings in the technical description and on the Enphase Envoy.

The Enphase Envoy Communications Gateway

The Envoy is an integral component of the Enphase Energy Microinverter system. It operates between the Enphase Microinverters and the Enphase Enlighten™ web-based monitoring and analysis software. The Envoy functions as a gateway and monitors the microinverters that are connected to the PV modules. The Envoy collects energy and performance data from the microinverters over in-home AC power lines. It then forwards that data to Enlighten, via the Internet, for statistical reporting.

The three key elements of an Enphase system are:

- the Enphase Microinverter
- the Enphase Envoy Communications Gateway
- the Enphase Enlighten™ web-based monitoring and analysis software

This integrated system maximizes energy harvest, increases system reliability, and simplifies design, installation and management. The following diagram shows the Envoy in the system.

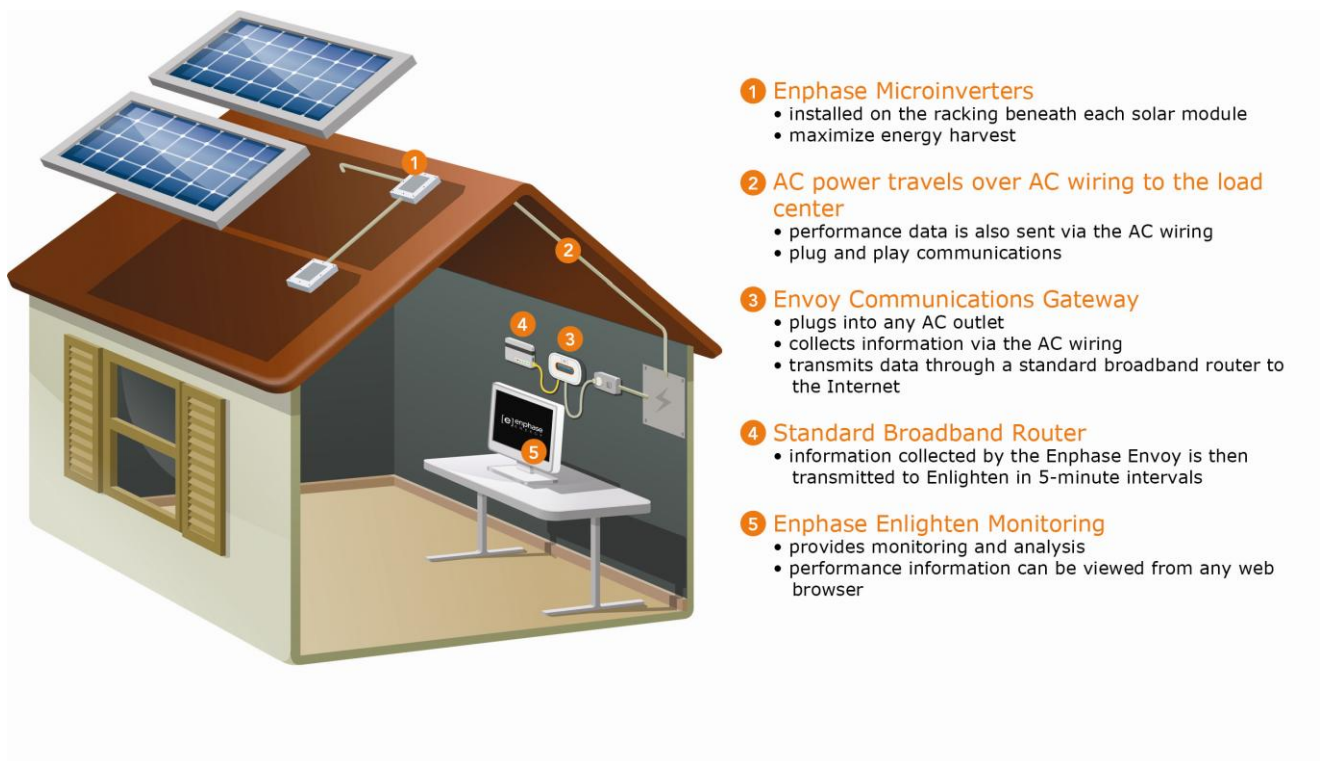

Other Elements in the Enphase System

The **Enphase Microinverter** is a fully integrated device that converts the DC output of the PV module into electric-utility compliant AC power. In addition to performing the DC to AC conversion, it maximizes the PV modules' energy production by using a sophisticated Maximum Power Point Tracking (MPPT) algorithm. This integrated system maximizes energy harvest, increases system reliability, and simplifies design, installation and management.

The **Enphase Enlighten** web-based monitoring and analysis system analyzes the per-module data collected by each communicating microinverter. Enlighten automatically detects any shortfall in energy production, identifies possible causes, and suggests solutions. Enlighten constantly monitors every microinverter connected to the Envoy.

How the Envoy Communications Gateway Works

Installation and operation of the Envoy requires no special computer or networking knowledge, nor any specialized equipment. The Envoy simply connects to the on-site router for communications with the Enphase Enlighten monitoring and analysis website. The Envoy communicates with the individual microinverters using the existing power lines in the residence or business.

After the Envoy is installed and completes its initial scan, it maintains an internal database of all known Enphase Microinverters at the site it manages. At regular intervals, the Envoy polls each microinverter for its energy data. Using the site's broadband router, the Envoy then forwards that information to the Enphase Enlighten monitoring and analysis website. The Envoy also reports any error conditions that affect itself or the microinverters. You can view both energy data and error conditions in the Enphase Enlighten web-based monitoring and analysis system.

The Envoy incorporates power line and Internet communications functions. As shown in the following diagram, one side of the Envoy communicates with the microinverters through power lines at the site. The other side of the Envoy communicates with the Internet using a standard Ethernet/network cable plugged into your broadband router.

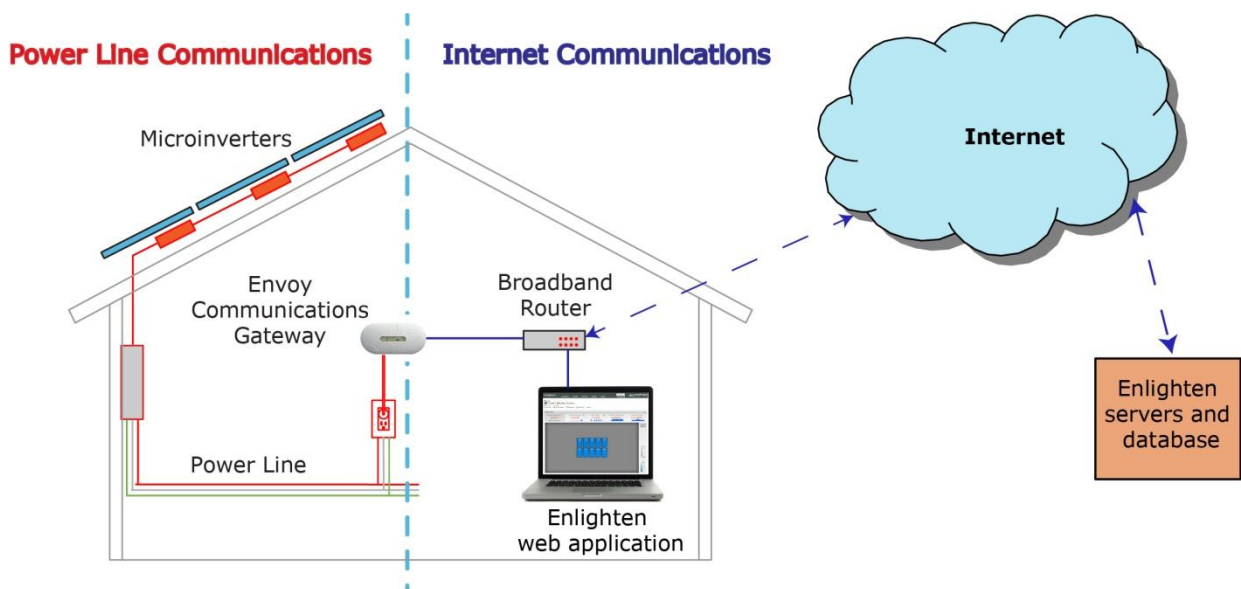



Envoy Installation

Preparation

Before installing the Envoy, make sure that the site meets the following minimum requirements:

- Standard AC electrical outlet is available

If you plan to use Enlighten web-based monitoring and analysis, additional requirements include:

- Always-on broadband Internet connection
- Broadband router with spare Ethernet port.
- Up-to-date web browser to view Enlighten. Supported browsers are Internet Explorer 8 or higher, Firefox 3.6 or higher, Chrome 5 or higher, and Safari 4 or higher. Enlighten requires Adobe Flash Player 10 or higher.

Check the Envoy shipping box for the following items:

- Envoy Communications Gateway
- Ethernet cable
- AC power cord
- Power line communication bridges
- Envoy Installation and Operation Manual
- Read This First document

Installation Flow

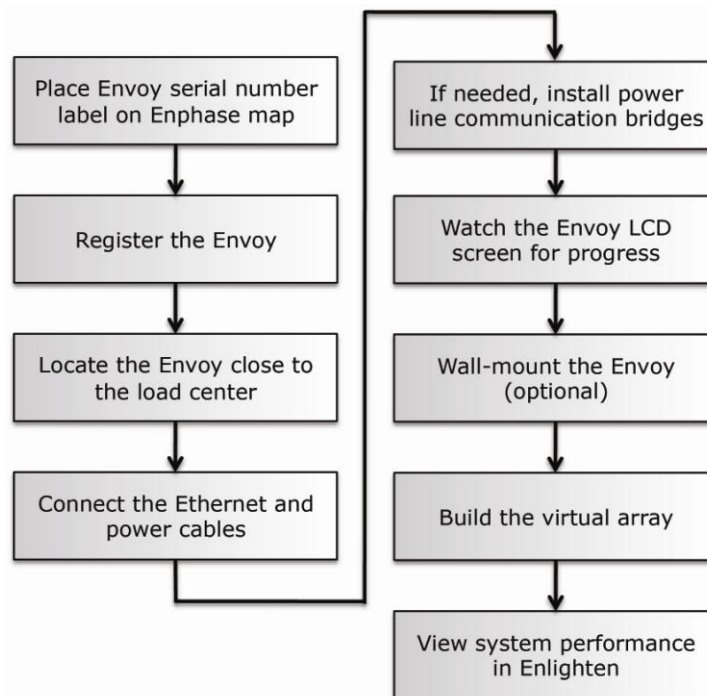

Install the Envoy

To install the Envoy, perform the steps below while referring to the diagram shown.

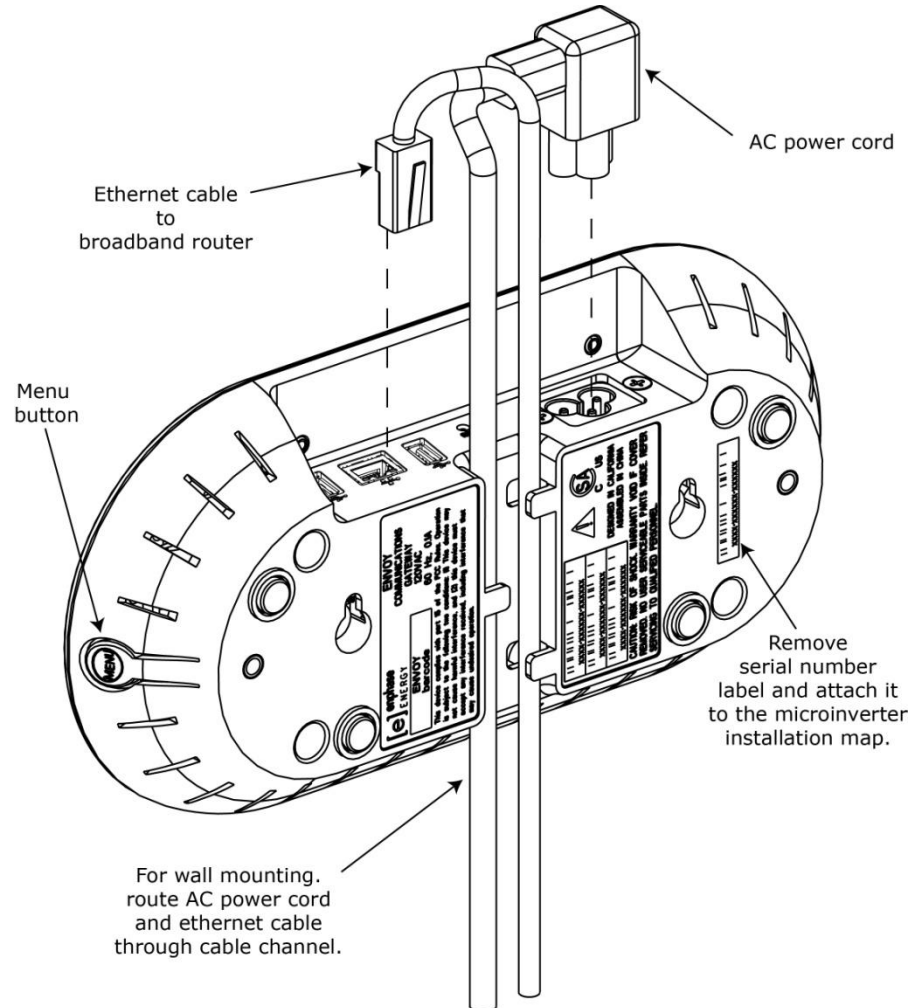

1. Add Serial Number Label to Map

- Remove the Envoy removable serial number label as shown in the diagram.
- Attach the serial number label to the microinverter installation map. (This applies to new installations only and is not necessary for an Envoy replacement.)

2. Register the Envoy

Register the Envoy at the beginning of the PV installation.

- Visit <http://enlighten.enphaseenergy.com/register>.
- If not already done, register the site owner information in the online form.
- Register the Envoy serial number in the space provided in the online form.

3. Find a Location for the Envoy

Enphase recommends that the Envoy be placed as close to the load-center as possible. This ensures that the Envoy receives the strongest possible signal from each microinverter.

- a. Locate an electrical outlet **close to the site's load center**. Place the Envoy so that its AC cord can reach this outlet.
- b. The Envoy can be placed on a table or it can be wall mounted. For wall mounting instructions, see **Wall Mounting** on page 13.

4. Connect Ethernet and Power Cables

- a. Plug the Ethernet cable into the Ethernet port on the Envoy.
- b. Plug the other end of the cable into a spare port on the broadband router.

The Envoy needs to obtain a DHCP (Dynamic Host Configuration Protocol) IP address and have a path to the Internet. The Envoy will request a dynamically assigned (DHCP) IP address from the broadband router during the power-up sequence.

Two small green LEDs on the Ethernet port indicate link and activity. One LED will be solid green, and the other will blink green every few seconds.



NOTE: Next to the Ethernet port on the Envoy, there are one or two ports identified by a USB symbol. These ports can be used to connect optional devices, such as a wireless communication device for the Enphase Environ Smart Thermostat, but cannot be used for a wired or a wireless Ethernet connection.

- c. Plug the AC power cord into the AC input on the Envoy.
- d. Plug the other end of the power cord into a dedicated 120VAC power outlet (not a power strip). For best results, the outlet should be near the load center.



WARNING! Do **not** plug the Envoy into a power strip, surge protector, or uninterruptible power supply (UPS). The surge suppression or filtering from a power strip or other protective device can substantially diminish communication performance. If possible, do not plug a power strip power cord into the same outlet that the Envoy is using. The surge suppression or filtering components of a power strip may still interfere with communications if they are close to the Envoy.

5. Connect Power Line Communication Bridges (Optional)

If the Envoy needs to be located away from the router, at a distance where an Ethernet cable is not practical, use the power line communication bridges provided with the Envoy or purchase a wireless Ethernet bridge. Bridges allow the Envoy to communicate with the broadband router without the need for additional Ethernet cabling.

Install the power line communication bridges:

- a. Plug one of the bridges into the same wall socket that the Envoy is using.
- b. Connect one end of the Ethernet cable into the Ethernet port on the Envoy.
- c. Connect the other end of that Ethernet cable into the bridge.

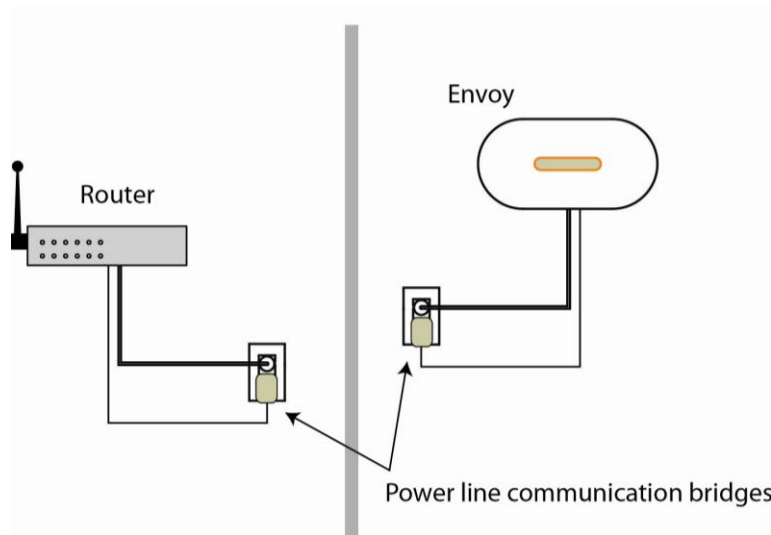

- d. Plug the other bridge into a wall-socket near your broadband router.
- e. Connect one end of a second Ethernet cable into that second bridge.
- f. Connect the other end of that Ethernet cable into the broadband router.
- g. Reapply power to the Envoy to force it to refresh its IP address.

6. Check the Envoy's Progress

After installing your Envoy, it will automatically perform a Communication Check as described on page 19.

- a. Watch the LCD display for progress, noting the number of bars shown in the communication check.
- b. See page 19 for more information on running a Communication Check.
- c. Refer to Initial Screen Displays on page 15 for more information.

7. Wall Mount the Envoy (Optional)



NOTE: Before mounting the Envoy, it is best to perform a Communication Check as described on page 19 to optimize the location of your Envoy.

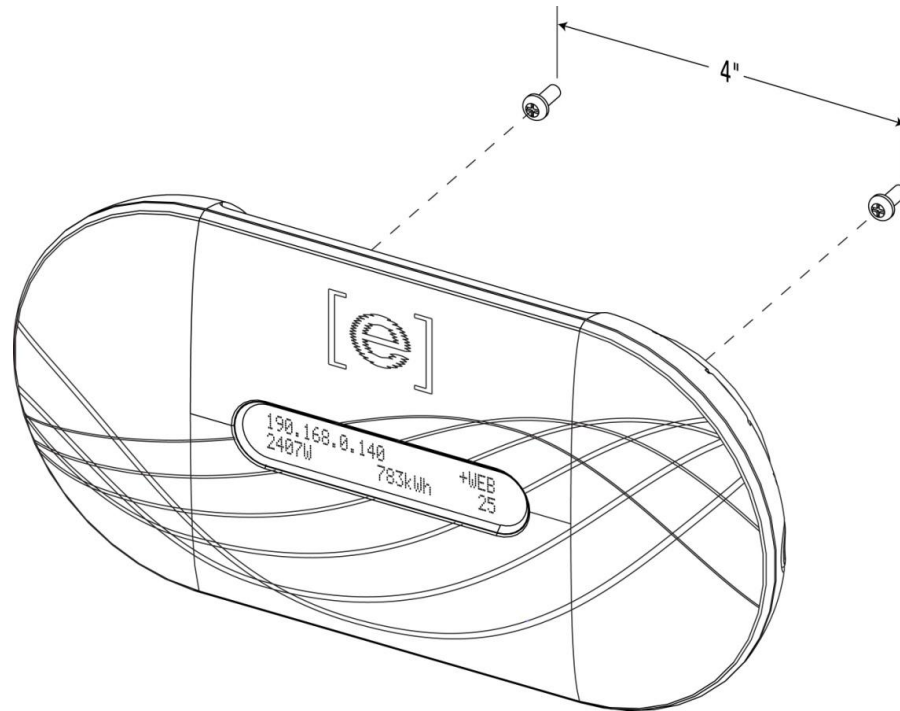

After you have positioned your Envoy for optimal communications and it has begun to detect devices, you may want to mount the Envoy on a wall. To do this:

- a. Select a cool, dry, indoor location for the Envoy.
- b. Use two drywall screws or wall anchors (not included in kit) to affix the Envoy to the wall, mounted at the dimensions shown. You will need two #8 (4.166 mm or 0.164 inch diameter); maximum screw head diameter is 8.9mm (0.35 inches).
- c. Slide the Envoy onto the mounting screws, aligning the Envoy screw holes with the screws installed in step b.

8. Build the Virtual Array

When the system is energized and the Envoy detects all the installed microinverters, you can create the virtual array in Enlighten from the Enphase map you created. Once the virtual array is built, Enlighten displays a graphic representation of the PV system. It also shows detailed current and historical performance information. Please go to <http://www.enphase.com> for more information on the Enphase Enlighten web-based monitoring and analysis software.



Envoy Operation

Initial Screen Displays

It takes less than five minutes for the Envoy to be ready to work after applying power. This five-minute period is known as a boot sequence. You will know the Envoy has completed booting and has started normal operation when it displays both an IP address and the "+Web" status indication in the LCD screen. The boot sequence is shown:

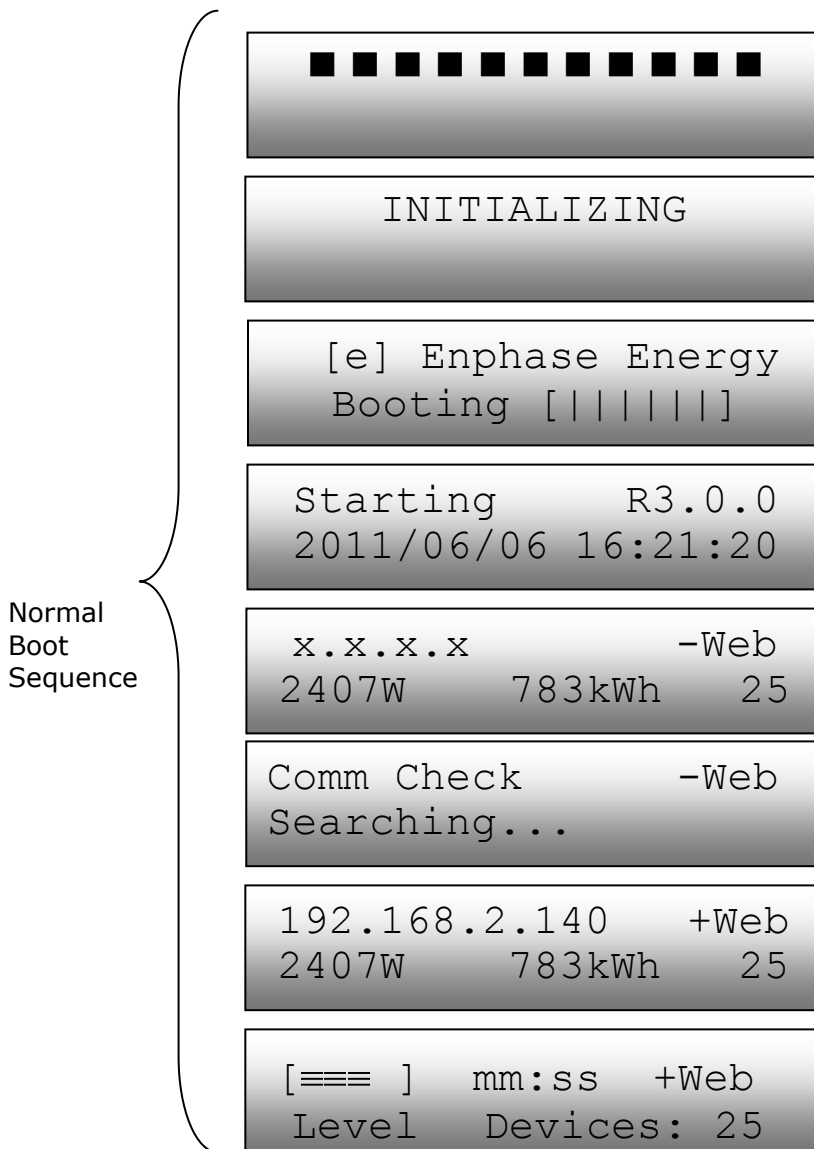

The Envoy normally displays "-Web" for 2 to 3 minutes after the first start up. It then sends the first report to Enlighten. If Enlighten responds, the Envoy displays +Web. Power production will show as 0W and 0kWh until the microinverters are discovered and power production begins.

First Scan for Microinverters

A newly installed Envoy automatically performs an initial scan to discover all of the microinverters that are installed and powered up at the site. This initial scan continues to search for new microinverters for seven days from initial start up of the Envoy. The purpose of this long scanning period is to account for additional microinverters that may be installed during this initial seven-day time frame. This one-time process is not repeated. During the scan, you will notice some values increasing on the Envoy display.



NOTE: If you power up the Envoy, even for just a few minutes, the seven-day scan begins at that point. If you then power it back down and leave it off until you are ready to discover the microinverters, the initial scan may have expired. A new scan can be initiated, and will be required if the installation is done in stages over more than seven days. The steps for initiating a new device scan are described on page 20 of this manual.

The Envoy identifies each device by its unique serial number. If a microinverter is ever added or replaced at the site, you must initiate a new scan so that the Envoy can discover the new microinverter. The steps for initiating a new device scan are described on page 20 of this manual.

After the Envoy has detected at least one new device, it will automatically enter Priority Scan mode. The LCD screen will display:

Priority Scan
Is Active



NOTE: No power production data will be collected or displayed on the Envoy or in Enlighten while Priority Scan is active. Also, the Communication Check function will not operate during this period.

When the Envoy does not detect a device during a polling interval (usually 5 minutes), it will exit Priority Scan mode. If, subsequently, the Envoy detects another device, it will return to Priority Scan mode. It will remain in this mode until it again completes an interval where no devices are detected.

Normal Operation

Once the Envoy completes a scan, it begins or resumes normal operation. At this point, the indicators in the LCD screen show current values for your system. This is the home screen:

192.168.2.140 +Web
2407W 783kWh 25

The data on the home screen may take a few minutes to appear after starting up the Envoy or initiating a scan. Information shown during normal operation includes:

- Local IP address, for example: **192.168.2.140** (your actual local IP address will be different). The Envoy will attempt to get a dynamically assigned DHCP (Dynamic Host Configuration Protocol) IP address during power up sequence. The Envoy uses the DHCP IP address as a path to the Internet. If 169.254.120.1 is shown, the Envoy has not yet acquired a dynamic IP. Refer to Troubleshooting on page 26, if this address continues to display.
- Web connection indication: **+Web**. The web status indicates whether the Envoy is connected to Enlighten.
- Indication of the present power-production, in watts: **(n)W** (where n is a number)
- Indication of the life time kilowatt hours reported to this Envoy: **(n)kWh** (where n is a number)
- Indication of the number of online microinverters producing power and reporting in to the Envoy: **(n)** (where n is a number). The number of microinverters displayed will be zero at night.

After the Envoy establishes an IP address and the web connection, the Envoy periodically contacts an NTP (Network Time Protocol) server so that it can maintain an accurate local time.

Using The Envoy LCD Menu

You can use the Envoy Menu button located on the right side of the Envoy to access the Envoy LCD menu.

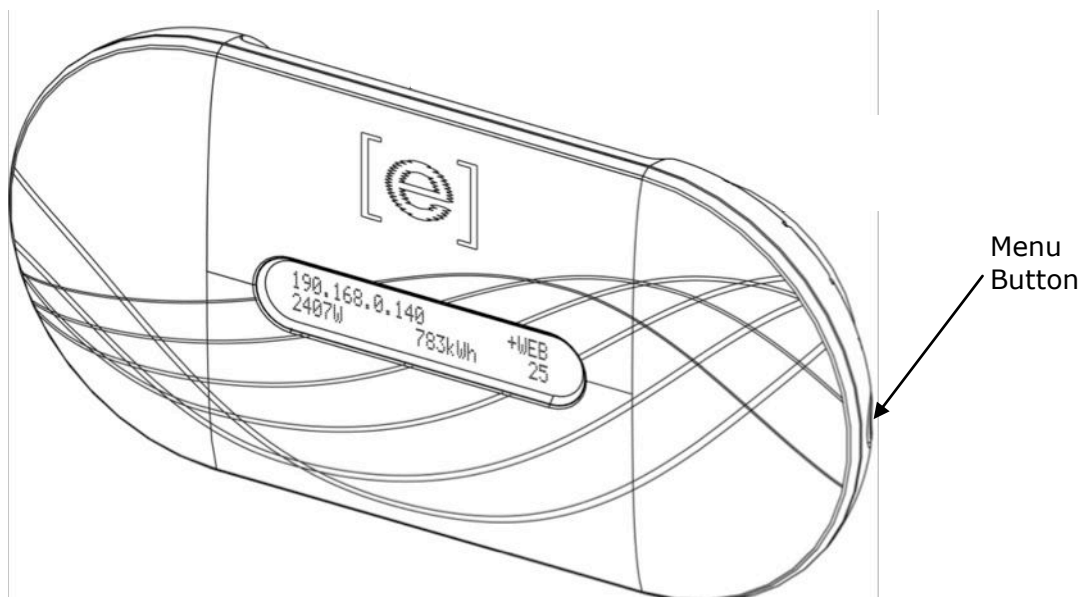

1. Press and hold this button; after two seconds you will see the Envoy menu in the Envoy's LCD screen.

2. Continue holding the Menu button. Menu items will appear in the following order:

Exit Menu

Enable
New Device Scan

Disable
New Device Scan

Enable
Communication Check

Disable
Communication Check

View Grid
Configuration

Get New IP Address

Enable Connection
To Enphase

Disable Connection
To Enphase

Select New Locale

To select a menu item, release the Menu button when the desired menu item appears. The menu continues to cycle as long as you are pressing the Menu button. The **Exit Menu** option returns to the normal (default) display.

See the following sections for detailed procedures.

Performing a Communication Check

If, when you are installing the Envoy, you are unsure of where it should be located for maximum performance, you may want to install the Envoy in various locations and check signal strength. Normally, a communication check starts automatically after an Envoy restart. Alternatively, you can initiate a communication check with the Envoy Menu button, or through the administration page when connected to the Envoy local interface with a computer, or via Enlighten (Refer to Using Enlighten to Check Envoy Status on page 25).



NOTE: If a Priority Scan is active, the Communication Check will not occur until the Priority Scan has expired. If you need to run a Communication Check, you can unplug the Envoy and then plug it in again or wait until priority scanning has ended during which time the signal bars will return.



NOTE: Device scans and communication checks can only be successfully performed during daylight hours when the microinverters are powered by the PV modules.

To use the Envoy Menu button to initiate a communication check:

1. Press and hold the Menu button on the right side of the Envoy to bring up the Envoy menu on the LCD screen.
2. When the LCD screen displays "Enable Communication Check", release the Menu button.



Enable
Communication Check

The LCD screen then reads:



Comm check enabled
for 20min

The Envoy begins a 20-minute communication check to assess the signal strength between the Envoy and the microinverters detected at the site. Until the Envoy begins detecting microinverters, the display reads:



Comm Check +Web
Searching...

When the Envoy begins detecting microinverters, the display reads:



The Level indicator in the LCD screen may display any number of bars from zero to five.



NOTE: Until microinverters are detected, the Level indicator shows no bars.

You can assume that signal strength is acceptable if three to five bars are displayed and all devices are accounted for. A number of 1-2 may not be effective for consistent communication.

3. If fewer than three bars are displayed, refer to Power Line Communication Troubleshooting on page 26.

Remaining minutes and seconds in Comm Check are displayed (“mm:ss” in the example). The “Devices” counter displays the number of microinverters detected and will increase until all microinverters are detected. Ultimately, the number of microinverters detected should match the number of installed microinverters.

4. After 20 minutes, the communication check automatically stops. If you want to end the communication check before it times out, press and hold the menu button to activate the Envoy menu. When “Disable Communication Check” displays, release the menu button.

Initiating a Scan for New Microinverters

If you add additional microinverters to an existing system or replace a microinverter, you will need to run a scan to detect the new devices. To initiate a scan after you add new microinverters to an existing Enphase system perform the following steps.

Alternatively, you can initiate a scan through the administration page when connected to the Envoy local interface with a computer, or via Enlighten (Refer to Using Enlighten to Check Envoy Status on page 25).

1. Press and hold the Envoy Menu button; after two seconds you will enter the Envoy menu.
2. Continue holding the Menu button; when the LCD screen displays “Enable New Device Scan”, release the Menu button.



The LCD screen then reads:

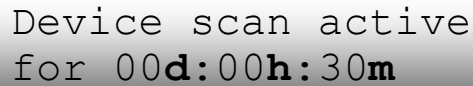

Device scan active
for 00**d**:00**h**:30**m**

The Envoy begins a 30-minute scan (if a longer scan is not already in progress) to identify all of the microinverters deployed at the site.

3. Use your previously issued username and password to check for the new microinverter in Enlighten. If you do not have a link to Enlighten, go to www.enphase.com and click **Enlighten Login**. From here you can register (if not already done) and view data on a per-microinverter basis (and, hence, a per-PV module basis).
4. To disable or cancel a scan, press and hold the Envoy Menu button for two seconds to view the Envoy menu. When the LCD screen displays: "Disable New Device Scan", release the Menu button.



Disable
New Device Scan

Viewing the Grid Configuration

To view the grid configuration (trip points profile) for the site, do the following.



Note: You cannot change the grid profile using this menu. To change this profile, refer to Manage the Grid Profile on page 31.

1. Press and hold the Envoy Menu button; after two seconds you will see the Envoy menu.
2. Continue holding the Menu button; when the LCD screen displays "View Grid Configuration", release the Menu button.



View Grid
Configuration

The LCD screen then reads:



Gathering Grid
Configuration Data

If a grid profile **has not** been applied, the following screen is displayed:

```
No Grid
Config. Applied
```

This indicates that the microinverters are not yet configured with a grid profile.

Configure these settings as described in Manage the Grid Profile on page 31. You can press the menu button to exit this process.

If a grid profile **has** been applied, the following screens are displayed. You can press the menu button at any time to exit this process.

<pre>(n) total devices</pre>	<p>Number of microinverters detected.</p>
<pre>(n) unsettable devices</pre>	<p>Number of microinverters that cannot be set with a grid profile.</p>
<pre>(n) devices are set with (local spec)</pre>	<p>Number of microinverters that are set with a grid profile and the name of the specification being used.</p>
<pre>(n) are propagating with (local spec)</pre>	<p>Number of microinverters that are in the process of being set and the name of the specification being used.</p>
<pre>(n) devices have failed</pre>	<p>Number of devices that failed to be set with a grid profile.</p>
<pre>Checking grid config Select to exit</pre>	<p>Updating grid configuration data.</p>

3. Press the menu button to exit this menu.

Enabling a Connection to Enphase

The Enable Connection to Enphase menu item creates a secure connection to Enphase allowing Enphase personnel to troubleshoot the system remotely.

A rectangular LCD screen with a black border and a light gray background. The text 'Enable Connection To Enphase' is displayed in a monospaced font, centered on the screen.

The LCD screen now reads:

A rectangular LCD screen with a black border and a light gray background. The text 'Enabling Connection' is displayed in a monospaced font, centered on the screen.

Once the connection is open, the LCD will return to the default display.

Disabling a Connection to Enphase

The Disable Connection to Enphase menu item closes the secure connection to Enphase.

A rectangular LCD screen with a black border and a light gray background. The text 'Disable Connection To Enphase' is displayed in a monospaced font, centered on the screen.

The LCD screen now reads:

A rectangular LCD screen with a black border and a light gray background. The text 'Disabling Connection' is displayed in a monospaced font, centered on the screen.

Once the connection is closed, the LCD will return to the default display.

Selecting a New Locale (Change Language Display)

You can set the LCD to display in English, French, Italian, or German. To do this:

1. Press and hold the Envoy Menu button; after two seconds you will enter the Envoy menu.
2. Continue holding the Menu button; when the LCD screen displays "Select New Locale", release the Menu button.

A rectangular LCD screen with a black border and a light gray background. The text 'Select New Locale' is displayed in a monospaced font, centered on the screen.

3. The Envoy LCD panel will scroll through the available locale settings. When you see the setting you need, press the Menu button and hold for two seconds.

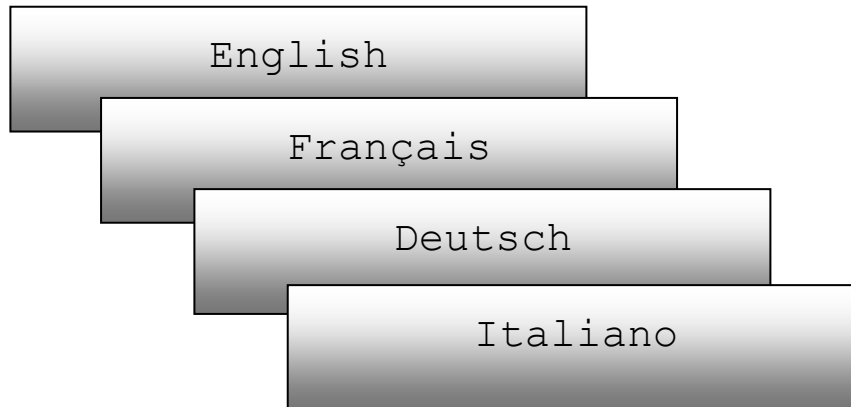

How the Envoy Works with Enlighten

The Envoy operates between the Enphase Microinverters and the Enphase Enlighten web-based monitoring and analysis system. The Envoy collects energy and performance data from the microinverters and forwards that data to Enlighten, via the Internet, for statistical reporting.

Once you have registered the system and successfully installed the Envoy, Enphase will set up an account for the site owner. You can then use Array Builder, a tool available to installers, to build the virtual array. You will need to use the installation map you created during installation as a reference during this task.



NOTE: Go to <http://www.enphase.com/support/learningcenter> to view an Array Builder demo.

If you do not already have an account, please go to www.enphase.com for more information on Enphase Enlighten web-based monitoring and analysis.

When you complete these steps, Enphase sends account information to the site owner so that they can log in to the Enlighten website and view system performance.

Enlighten provides a wide range of information on system and PV module performance. A graphical representation of the PV array provides “at a glance” information on the status of each PV module. You can also access more detailed information, including current and lifetime performance metrics. You can even access Enlighten on your mobile device and view real-time performance information wherever you are.

Networking and Firewall Info

The Envoy communicates with the Enphase Enlighten website by initiating outbound TCP (Transmission Control Protocol) connections to Enphase over HTTPS (Hypertext Transfer Protocol over Secure Socket Layer) (TCP:443). The Envoy uses NTP (Network Time Protocol) (UDP:123) to periodically synchronize time/date with an external pool of NTP servers. You do not need to open any inbound firewall ports for normal operation.



NOTE: The Envoy automatically reports system performance data to Enphase upon connection to the Internet. Please consult the Enphase privacy policy at <http://www.enphase.com/privacy/> to learn more about Enphase's use of this data.

Using Enlighten to Check Envoy Status

To check status of Enphase equipment, do the following:

1. Log on to Enlighten to view the array. Click **Inverters**.

A list of equipment appears that including the Envoy(s) all of the microinverters that the Envoy has detected. The column on the far right lists the status of each microinverter.

2. To view status information for the Envoy, click the Envoy serial number.

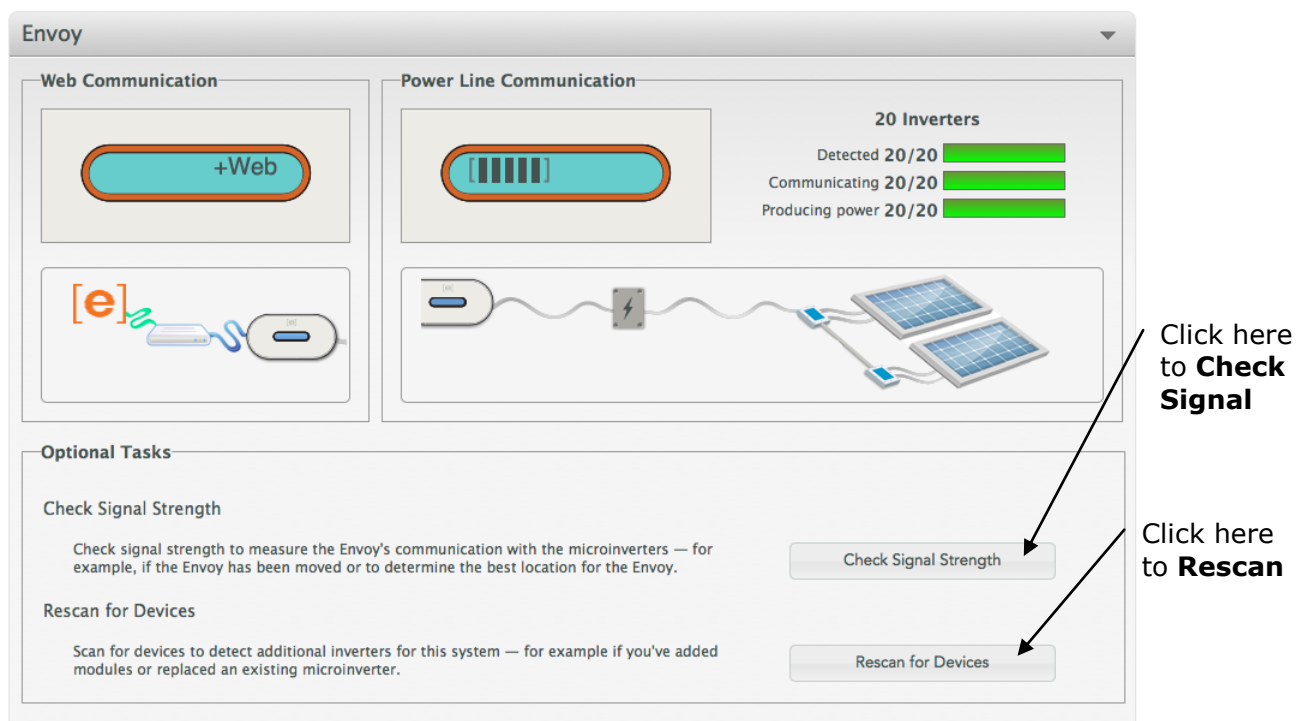

The screenshot shows the Envoy status page with the following details:

- Web Communication:** A button labeled '+Web' and a diagram showing the Envoy connected to a computer.
- Power Line Communication:** A signal strength indicator, a summary for '20 Inverters' (Detected 20/20, Communicating 20/20, Producing power 20/20), and a diagram showing the Envoy connected to solar panels.
- Optional Tasks:** Two buttons: 'Check Signal Strength' and 'Rescan for Devices'. Arrows point from these buttons to external text labels: 'Click here to Check Signal' and 'Click here to Rescan'.

3. From here you can choose to **Check Signal Strength** or **Rescan for Devices** as needed.

Troubleshooting

The following sections describe possible problems and solutions. For information on system status and event messages, see **Event Messages** on page 41.

For more extensive Troubleshooting information, refer to the manual, *Troubleshooting an Enphase Installation* at <http://www.enphaseenergy.com/support/downloads>.

Power Line Communication Troubleshooting

At power-up, the Envoy performs a "Communication Check". After a few minutes, it will display a number of bars in the LCD screen. This value, from 0 to 5, indicates the signal strength of the power line communication between the Envoy and the microinverters. A number from 3-5 is good. A number of 1-2 is not ideal. Zero bars means that either the Envoy needs to be relocated, or there are one or more electrical appliances causing interference. Troubleshoot power line communication issues as follows.



PROBLEM: The microinverter count doesn't match number of installed units.

This may indicate that the Envoy is not done scanning/discovering the entire array. Alternatively, it may indicate that the Envoy is having difficulty communicating over the power lines. It could also be a result of low light levels and the PV module voltage being too low for the microinverter to power up.

- Make sure that the Envoy is plugged directly into the wall and **not** into a power strip or surge protector.
- Relocate your Envoy as close to the electrical service-panel (load-center) as possible. This ensures that the Envoy receives the strongest possible signal from each microinverter.
- Try unplugging any other device that may be sharing the outlet with the Envoy. Or, as an alternative, plug the Envoy into a circuit that supports fewer electronic appliances. Appliances sharing a receptacle with the Envoy may interfere with power line communication.
- If this problem occurs when light levels are low, try again during daylight hours.

PROBLEM: Envoy displays fewer than three bars. Follow the procedure above.

PROBLEM: Envoy displays zero bars. The following conditions may exist.

1. Is there a Phase-imbalance?

- Ask the Electrician to measure the conductors and neutral line to verify that the phases are balanced. In cases where the phases are not balanced, electricians must recheck their work.

2. **Is the system energized?** PV modules power microinverters, PV modules provide power only during daylight hours, and microinverters communicate only when powered.
 - Run another scan during daylight hours.
 - Check that the circuit breaker(s) for the PV array are in the "ON" position. For the Envoy to communicate with the microinverters, the PV circuit breakers must be in the "ON" position in the electrical load-center.
 - Verify that the PV modules are connected to the microinverters.

3. **Envoy plugged into a circuit on the primary load-center, but the PV circuit breakers are on a downstream sub-panel:** The primary load-center is full and doesn't have additional capacity to add circuit breakers.
 - Add a subpanel with a small subset of circuit breakers. In this case, it is best to add an additional 5-Amp circuit breaker and then run an outlet off that subpanel. Plug the Envoy into that outlet, so that it can be close to the PV circuit breaker.

Local Area Networking Troubleshooting

PROBLEM: IP address issues. If the IP address displayed on the Envoy's LCD screen is 169.254.120.1, or if the IP address does not match the DHCP subnet on the internal network, this means that the Envoy was unsuccessful in obtaining a DHCP lease from the router.

- Check network connectivity to the router or other DHCP server. You may also wish to contact your Internet Service Provider or refer to your router documentation for assistance.
- Check that you are using a broadband router and not a switch or a hub. Many hubs and switches cannot provide a DHCP lease and may not allow the Envoy to connect to the web.
- Use the Envoy menu button to "Get New IP Address".
- Unplug all units in the chain, applying power again in this order: Modem, Router, and Envoy. Allow a few minutes for the IP address to be reassigned.

PROBLEM: LCD screen displays "-Web". This means that the Envoy has no connection to the Enlighten website.

- Check network connectivity to the router. You may also wish to contact your Internet Service Provider or refer to your router documentation for assistance.
- Allow a few minutes longer. If the Envoy has recently received a valid IP address, it will likely display +Web momentarily.

PROBLEM: LCD screen displays "Envoy Failure +Web or -Web". This message displays after the Envoy has tried unsuccessfully three times to initialize.

- Unplug the Envoy from the electrical outlet and plug it in once again. Leave it in place for at least 15 minutes. If it continues to display Envoy Failure or if it never moves beyond the Initialization stage, call Enphase Customer Support.

PROBLEM: The Envoy is in a location that yields a good signal-strength, but using an Ethernet cable here is not practical:

- In this case, you may need to use power line communication bridges or a wireless Ethernet bridge.

Envoy Local Interface

Connection to the Enphase Enlighten web-based monitoring and analysis website requires an Internet connection. However, if there is no Internet access at the installation site, it is still possible to communicate directly with the Envoy using the Ethernet port and a personal computer with a web browser. The following steps describe how to access the Envoy data through the local connection.

1. Connect one end of the Ethernet cable supplied with the Envoy to the Ethernet port on the Envoy.
2. Connect the other end of the Ethernet cable to the Ethernet port of the computer.
3. Open the Internet browser application on the computer.
4. In the browser address window, enter the IP address displayed in the LCD screen of the Envoy.



NOTE: If you fail to make a connection at this point, you can manually configure your subnet to 169.254.120.2 and subnet mask to 255.255.0.0. If this does not correct the problem, contact Enphase Customer Support.

Once the browser has successfully connected with the Envoy, the home screen is displayed in the browser window.

Home Screen

The home screen provides a system overview and shows the current status of the microinverters that have been identified by this Envoy. From this screen, you can access other screens in the interface.

Envoy Serial Number: 991032310713
enlighten

[Home](#)
[Production](#)
[Inventory](#)
[Administration](#)
Language English

System Overview

System Operation

Connection to Microinverters
Connection to Web

System Statistics

Lifetime generation	936Wh
Currently generating	199W
Last connection to website	0 minutes
Number of Microinverters	4
Number of Microinverters Online	1
Current Software Version	D3.0.0 (3bd0e0)
Database Size	303 kB (0 % full)
Current Timezone	US/Pacific
Envoy Mac Address	00:1D:C0:04:61:0B
Envoy Power Line Device	480-00008-r01-v02.0a.19

Events

Event Id	Event	Device	Date
40	Grid Gone: Clear	ser# 121106542302 pcu channel 1	Wed May 25, 2011 02:24 PM PDT
39	Grid Gone: Set	ser# 121106542302 pcu channel 1	Wed May 25, 2011 02:22 PM PDT
38	Grid Instability: Set	ser# 121106542302 pcu channel 1	Wed May 25, 2011 02:22 PM PDT
37	Grid Instability: Clear	ser# 121106542302 pcu channel 1	Wed May 25, 2011 02:14 PM PDT
36	Grid Gone: Clear	ser# 121106542302 pcu channel 1	Wed May 25, 2011 02:09 PM PDT

Production Screen

To view system energy harvest statistics for your system, click **Production** from the Envoy home screen to navigate to the production screen.

Envoy Serial Number: 991032310713
enlighten

[Home](#)
[Production](#)
[Inventory](#)
[Administration](#)
Language English

System Energy Production

System has been live since Wed May 25, 2011 12:03 PM PDT	
Time Period	Energy Generated
Currently	424W
Today	0Wh
Past Week	0Wh
Since Installation	1.10kWh

© 2007-2011, [e] Enphase Energy, Inc. All rights reserved. | [Licenses](#)

Inventory Screen

To view a listing of the devices in your system, click **Inventory** from any screen to navigate to the inventory screen.

Envoy Serial Number: 991032310713
enlighten

[Home](#)
[Production](#)
[Inventory](#)
[Administration](#)
Language English

System Inventory

New Device Scan Status

Scan Duration: (d:hh:mm)	7:00:00	Remaining Duration: (d:hh:mm)	6:21:11
Priority Duration:	Dynamic	Priority Scan	Inactive

[Device Scan Control](#)

Microinverter

HW Part Num	Installed	HW Serial Num	Device Status	Running Image - Updated	Assembly Part Num	Controller Part Num	Last Report
800-00103-r01	Wed May 25, 2011 12:05 PM PDT	121052487190	GFI Tripped DC Power Too Low Alert Active	520-00040-r01-v00.03.29 - Thu May 05, 2011 03:44 AM PDT	fff-ffff-rff-vff.ff.ff	480-00009-r01-v02.02.13	Wed May 25, 2011 02:50 PM PDT
800-00005-r07	Wed May 25, 2011 12:05 PM PDT	030834005974	DC Voltage Too Low	520-00001-r00-v00.04.20 - Tue Apr 26, 2011 07:09 PM PDT	fff-ffff-rff-vff.ff.ff	560-00001-r01-v03.03.09	Wed May 25, 2011 02:50 PM PDT
800-00037-r08	Wed May 25, 2011 12:05 PM PDT	030915024720	OK	520-00008-r01-v01.03.04 - Thu May 05, 2011 07:31 PM PDT	fff-ffff-rff-vff.ff.ff	480-00002-r01-v00.0b.12	Wed May 25, 2011 02:50 PM PDT
800-00107-r03	Wed May 25, 2011 12:03 PM PDT	121106542302	OK	520-00043-r01-v99.01.04 - Tue Apr 05, 2011 11:44 AM PDT	fff-ffff-rff-vff.ff.ff	480-00008-r01-v02.0a.19	Wed May 25, 2011 02:50 PM PDT

Table contains 4 rows

© 2007-2011, [e] Enphase Energy, Inc. All rights reserved. | [Licenses](#)

Administration Screen

The Administration screen of the Envoy local interface contains a number of configurable options. Click **Administration** to access this menu.



NOTE: For Envoy performance reasons, Enphase does not recommend giving the Envoy a publicly accessible IP address. However, if you must place the Envoy on a public-facing IP address, Enphase recommends that you change the admin password to disallow unauthorized modification to your Envoy. **(This situation is rare, since consumer-grade routers normally provide the Envoy with an internal network IP address that is not publicly accessible.)**

For reference, private/internal IP address space will be in the 192.168.x.x, 172.16(-31).x.x, 10.x.x.x or 169.254.x.x range. If you are unsure if your Envoy is on the public Internet, please see your network administrator or Internet Service Provider.



The default log in credentials for the Administration menu are:

Username: admin

Password: admin

Administration Screen Tasks

Several Administration Screen tasks are described in the following sections. Perform these tasks only when needed. Administration tasks include:

- Manage the Grid Profile
- Clear GFI Tripped Condition
- Set Device Scan Control
- Set Time Zone

Manage the Grid Profile

Each Grid Profile contains a set of trip points. Trip points are input voltage or frequency values that trigger the microinverters to shut down. These trip points vary from region to region.

In some regions and in some situations, microinverter trip points must be adjusted to account for high grid voltage or for local conditions. Grid profile management tasks include:

- Adjust system trip points for frequency and voltage if required by local utilities
- Reset trip points to default values
- View or verify current trip point settings

- Generate a report for confirmation of site settings to the utility or other authority having jurisdiction

Once all microinverters at the site are detected, the grid profile can be changed.

This feature is protected through use of a Change Token. Change tokens are issued on a per Envoy serial number basis. Call Enphase Customer Support for your profile Change Token as directed on the screen.

1. From the System Overview screen, click on **Inventory** and verify that all installed microinverters are detected.
2. Click **Administration** to access the Administration menu.
The default log in credentials for the Administration menu are:
Username: admin
Password: admin

The System Administration screen appears.

3. From the Admin menu, select **Device Grid Configuration**.

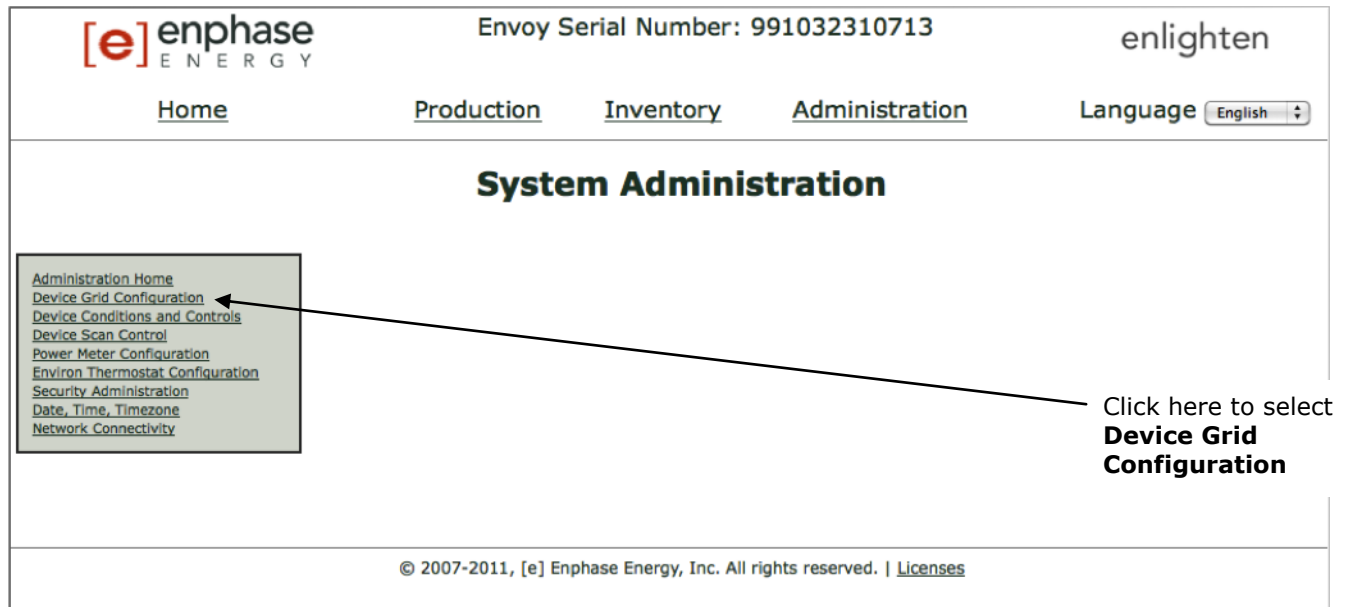

[e] enphase ENERGY Envoy Serial Number: 991032310713 enlighten

[Home](#) [Production](#) [Inventory](#) [Administration](#) Language

System Administration

- [Administration Home](#)
- [Device Grid Configuration](#)
- [Device Conditions and Controls](#)
- [Device Scan Control](#)
- [Power Meter Configuration](#)
- [Environ Thermostat Configuration](#)
- [Security Administration](#)
- [Date, Time, Timezone](#)
- [Network Connectivity](#)

Click here to select **Device Grid Configuration**

© 2007-2011, [e] Enphase Energy, Inc. All rights reserved. | [Licenses](#)

The Device Grid Configuration screen appears. This screen allows a licensed solar professional to select and apply the appropriate trip points for the solar installation.

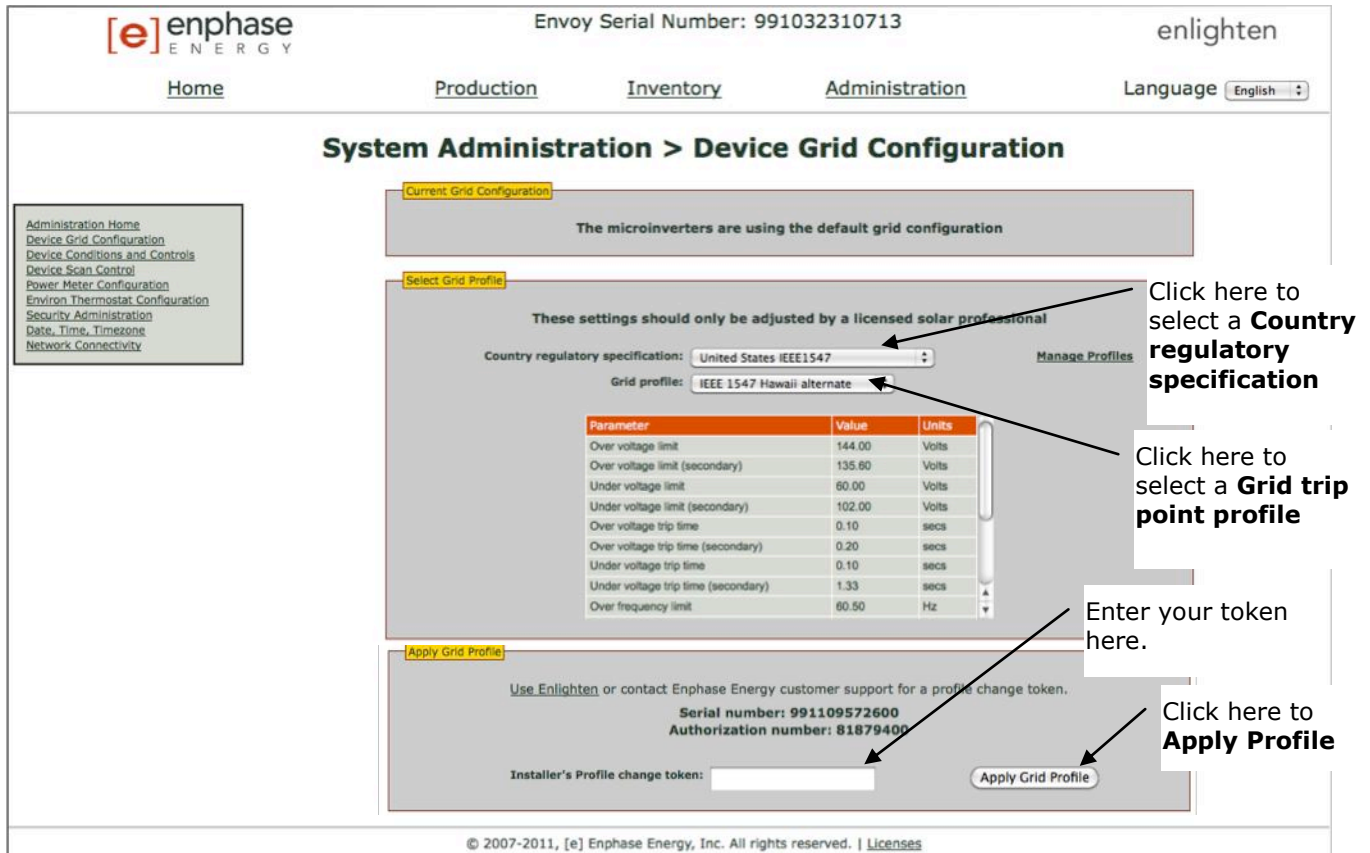

Administration Home
 Device Grid Configuration
 Device Conditions and Controls
 Device Scan Control
 Power Meter Configuration
 Environ Thermostat Configuration
 Security Administration
 Date, Time, Timezone
 Network Connectivity

enphase ENERGY Envoy Serial Number: 991032310713 enlighten
 Home Production Inventory Administration Language English

System Administration > Device Grid Configuration

Current Grid Configuration
 The microinverters are using the default grid configuration

Select Grid Profile
 These settings should only be adjusted by a licensed solar professional

Country regulatory specification: United States IEEE1547
 Grid profile: IEEE 1547 Hawaii alternate

Parameter	Value	Units
Over voltage limit	144.00	Volts
Over voltage limit (secondary)	135.60	Volts
Under voltage limit	80.00	Volts
Under voltage limit (secondary)	102.00	Volts
Over voltage trip time	0.10	secs
Over voltage trip time (secondary)	0.20	secs
Under voltage trip time	0.10	secs
Under voltage trip time (secondary)	1.33	secs
Over frequency limit	60.50	Hz

Use [Enlighten](#) or contact Enphase Energy customer support for a profile change token.
 Serial number: 991109572600
 Authorization number: 81879400

Installer's Profile change token:

Click here to select a **Country regulatory specification**

Click here to select a **Grid trip point profile**

Enter your token here.

Click here to **Apply Profile**

© 2007-2011, [e] Enphase Energy, Inc. All rights reserved. | [Licenses](#)

4. Select a **Country regulatory specification**.
5. Select a **Grid profile**.
6. Make note of the Envoy serial number and the authorization number on the screen. You will need to enter these values in the Enlighten website in the following steps.
7. Click the link to the Enlighten website. (If you do not already have an account, click "Enlighten Login" in the Enlighten website to register.)
8. Locate the Grid Profile Change Token widget.
 If you don't see this widget add it now:
 - Click "Add a widget."
 - Select "Grid Profile Change Token"
9. Enter the Envoy serial number.



10. Enter the authorization number from the Envoy Interface.

11. Click "Get Token"

Enter token here.

12. Copy the token.

13. Paste or enter the token in the Grid Profile screen.

14. Click **Apply Grid Profile**. This step propagates the settings to the microinverters. Available profiles include:

- IEEE 1547 Standard: The appropriate default for the majority of installations
- IEEE 1547 Hawaii alternate: Used only to satisfy HELCO and MECO Utility requirements and takes the AC frequency trip point down to 57.0Hz
- IEEE 1547 High Line ACV: Relaxes the high line AC voltage trip point slightly beyond the default while remaining within specification

The Apply Profile screen appears. This screen allows you to generate a report to confirm that the microinverters have been set with an updated grid profile.

15. Click **View Device Profile Report**.

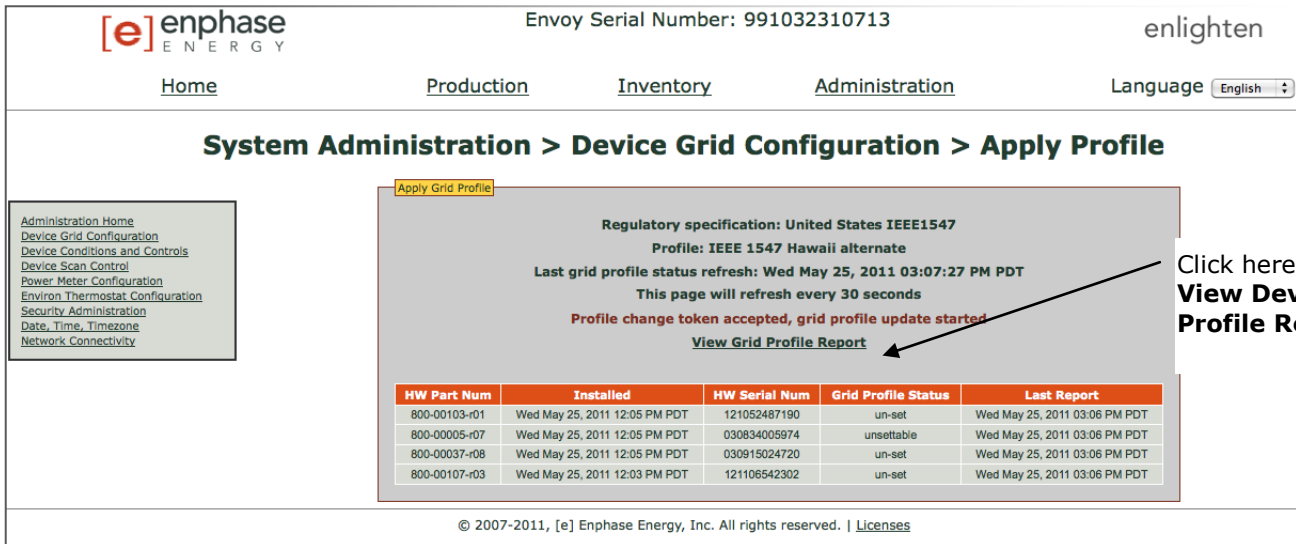

enphase ENERGY Envoy Serial Number: 991032310713 enlighten

Home Production Inventory Administration Language English

System Administration > Device Grid Configuration > Apply Profile

Apply Grid Profile

Regulatory specification: United States IEEE1547
 Profile: IEEE 1547 Hawaii alternate
 Last grid profile status refresh: Wed May 25, 2011 03:07:27 PM PDT
 This page will refresh every 30 seconds
 Profile change token accepted, grid profile update started
[View Grid Profile Report](#)

HW Part Num	Installed	HW Serial Num	Grid Profile Status	Last Report
800-00103-r01	Wed May 25, 2011 12:05 PM PDT	121052487190	un-set	Wed May 25, 2011 03:06 PM PDT
800-00005-r07	Wed May 25, 2011 12:05 PM PDT	030834005974	unsettable	Wed May 25, 2011 03:06 PM PDT
800-00037-r08	Wed May 25, 2011 12:05 PM PDT	030915024720	un-set	Wed May 25, 2011 03:06 PM PDT
800-00107-r03	Wed May 25, 2011 12:03 PM PDT	121106542302	un-set	Wed May 25, 2011 03:06 PM PDT

© 2007-2011, [e] Enphase Energy, Inc. All rights reserved. | [Licenses](#)

Click here to **View Device Profile Report**

The Device Profile Report screen appears

16. Enter the site information in the window provided.

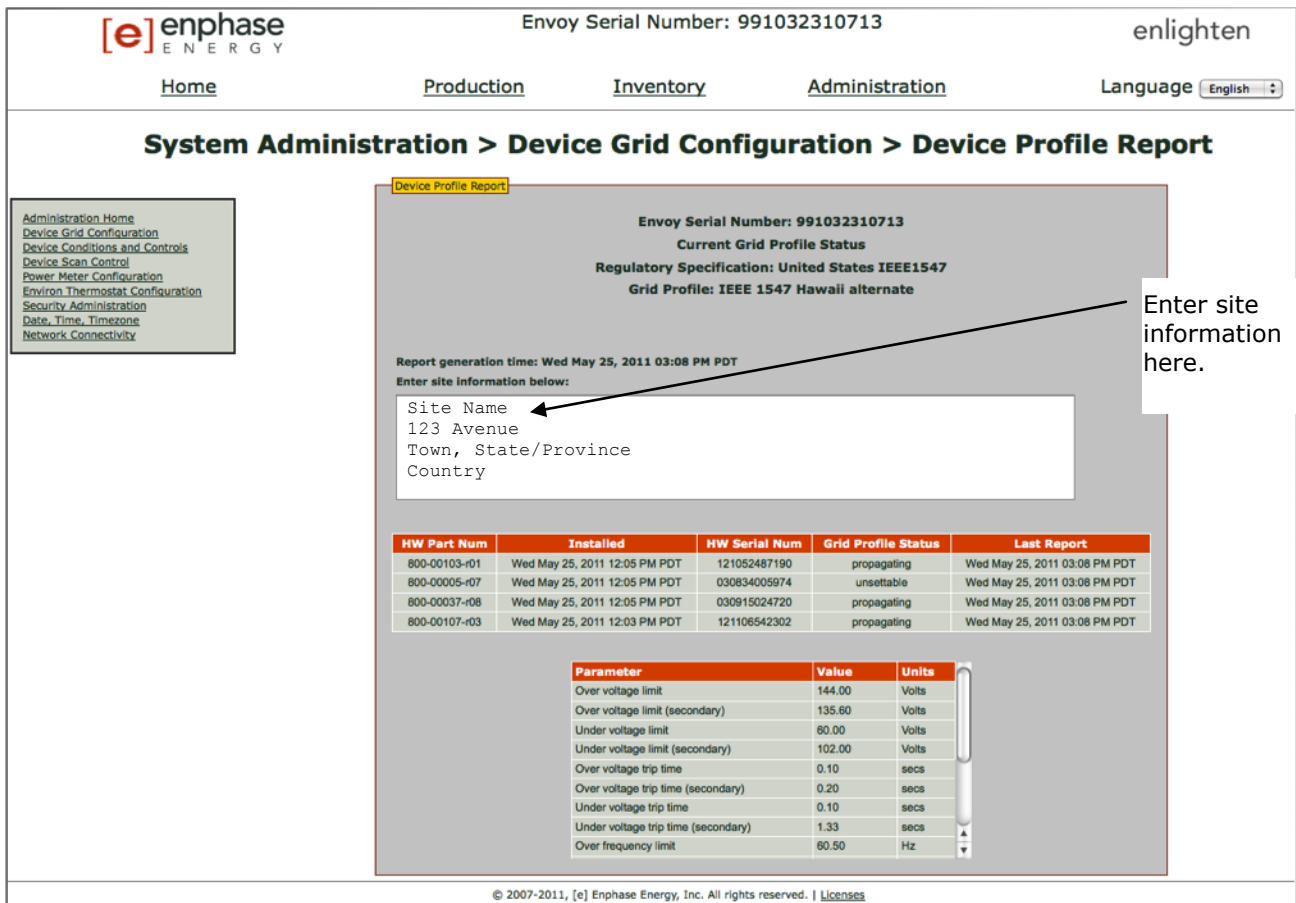

enphase ENERGY Envoy Serial Number: 991032310713 enlighten

Home Production Inventory Administration Language English

System Administration > Device Grid Configuration > Device Profile Report

Device Profile Report

Envoy Serial Number: 991032310713
 Current Grid Profile Status
 Regulatory Specification: United States IEEE1547
 Grid Profile: IEEE 1547 Hawaii alternate

Report generation time: Wed May 25, 2011 03:08 PM PDT
 Enter site information below:

Site Name
 123 Avenue
 Town, State/Province
 Country

HW Part Num	Installed	HW Serial Num	Grid Profile Status	Last Report
800-00103-r01	Wed May 25, 2011 12:05 PM PDT	121052487190	propagating	Wed May 25, 2011 03:08 PM PDT
800-00005-r07	Wed May 25, 2011 12:05 PM PDT	030834005974	unsettable	Wed May 25, 2011 03:08 PM PDT
800-00037-r08	Wed May 25, 2011 12:05 PM PDT	030915024720	propagating	Wed May 25, 2011 03:08 PM PDT
800-00107-r03	Wed May 25, 2011 12:03 PM PDT	121106542302	propagating	Wed May 25, 2011 03:08 PM PDT

Parameter	Value	Units
Over voltage limit	144.00	Volts
Over voltage limit (secondary)	135.60	Volts
Under voltage limit	80.00	Volts
Under voltage limit (secondary)	102.00	Volts
Over voltage trip time	0.10	secs
Over voltage trip time (secondary)	0.20	secs
Under voltage trip time	0.10	secs
Under voltage trip time (secondary)	1.33	secs
Over frequency limit	80.50	Hz

© 2007-2011, [e] Enphase Energy, Inc. All rights reserved. | [Licenses](#)

Enter site information here.

17. Use your browser to send this report to your printer or to save it to a file. After printing or saving the file, you can send it to the local regulatory agency to confirm the trip point settings.

The report will look like the following example.

Device Profile Report

Envoy Serial Number: 991032310713

Current Grid Profile Status

Regulatory Specification: United States IEEE1547

Grid Profile: IEEE 1547 Hawaii alternate

Report generation time: Wed May 25, 2011 03:08 PM PDT

Enter site information below:

Site Name
123 Avenue
Town, State/Province
Country

HW Part Num	Installed	HW Serial Num	Grid Profile Status	Last Report
800-00103-r01	Wed May 25, 2011 12:05 PM PDT	121052487190	propagating	Wed May 25, 2011 03:08 PM PDT
800-00005-r07	Wed May 25, 2011 12:05 PM PDT	030834005974	unsettable	Wed May 25, 2011 03:08 PM PDT
800-00037-r08	Wed May 25, 2011 12:05 PM PDT	030915024720	propagating	Wed May 25, 2011 03:08 PM PDT
800-00107-r03	Wed May 25, 2011 12:03 PM PDT	121106542302	propagating	Wed May 25, 2011 03:08 PM PDT

Parameter	Value	Units
Over voltage limit	144.00	Volts
Over voltage limit (secondary)	135.60	Volts
Under voltage limit	60.00	Volts
Under voltage limit (secondary)	102.00	Volts
Over voltage trip time	0.10	secs
Over voltage trip time (secondary)	0.20	secs
Under voltage trip time	0.10	secs
Under voltage trip time (secondary)	1.33	secs
Over frequency limit	60.50	Hz
Under frequency limit (secondary)	57.50	Hz
Under frequency limit	57.00	Hz
Over frequency trip time	0.10	secs
Under frequency trip time (secondary)	280.00	secs
Under frequency trip time	0.10	secs
Long term reconnect time	305.00	secs



Clear GFI Tripped Condition

A solid red status LED on the microinverter indicates the microinverter has detected a ground fault (GFDI) error. The LED will remain red and the fault will continue to be reported by the Envoy until the error has been cleared.

If a microinverter registers a GFI Tripped condition, you can attempt to clear this condition through the Envoy Interface. If the condition does not clear after you perform the following procedure, contact Enphase Energy customer support at 877-797-4743 or at support@enphaseenergy.com.

To send the Clear-GFI message to a microinverter:

1. From the Admin menu, choose **Device Conditions and Controls**.

enphase ENERGY Envoy Serial Number: 991032310713 enlighten

Home Production Inventory Administration Language English

System Administration > Device Conditions and Controls

Active Devices

Select	Serial Num	Part Num	Control Flags	Condition Flags	Last Report
<input type="checkbox"/>	121052487490	800-00103-r01		GFI Tripped DC Power Too Low Alert Active	Wed May 25, 2011 02:53 PM PDT
<input type="checkbox"/>	030834005974	800-00005-r07		DC Voltage Too Low	Wed May 25, 2011 02:53 PM PDT
<input type="checkbox"/>	030915024720	800-00037-r08		OK	Wed May 25, 2011 02:53 PM PDT
<input type="checkbox"/>	121106542302	800-00107-r03		OK	Wed May 25, 2011 02:53 PM PDT

Administration Home
Device Grid Configuration
Device Conditions and Controls
Device Scan Control
Power Meter Configuration
Environ Thermostat Configuration
Security Administration
Date, Time, Timezone
Network Connectivity

Delete Selected

Click here

© 2007-2011, [e] Enphase Energy, Inc. All rights reserved. | Licenses

2. Click on the **serial number** of the unit showing the GFI condition.



NOTE: Do not click or select the box under the column labeled **Select**.



3. In the clear-gfi box, select **set**.

4. Click **Send Command** to complete this task.

Device Scan Control

The Controlled device scan differs from other Envoy device scans in that it allows control over scan period, scanning method, and number of devices. When first installed, the Envoy initiates a seven-day scan. This initial seven-day scan is the only scan needed for most systems.



NOTE: At sites with more than 100 microinverters, we recommend specifying the total number of devices to be discovered in order to speed up the discovery process. See the following procedure for details.

A controlled scan should only be run as needed to detect new or previously undetected microinverters. You may want to use this feature in instances where you need to run a controlled device scan for a large site or for a site with communications issues.

To run a controlled scan:

1. From the Admin menu, choose **Device Scan Control**.
2. Enter a **Scan Duration** in days:hours:minutes (e.g., 0:00:60 to indicate zero days, zero hours, and 60 minutes). The scan duration will depend on many factors, such as number of devices to be detected and quality of power line communication. You may want to start with a one-hour scan and increase the duration as needed.



[e] enphase ENERGY Envoy Serial Number: 991032310713 enlighten

[Home](#) [Production](#) [Inventory](#) [Administration](#) Language English

System Administration > Device Scan Control

Administration Home

Device Grid Configuration

Device Conditions and Controls

Device Scan Control

Power Meter Configuration

Environ Thermostat Configuration

Security Administration

Date, Time, Timezone

Network Connectivity

Current Scan

Scan Duration: (d:hh:mm)	7:00:00	Remaining Duration: (d:hh:mm)	6:21:03
Priority Duration:	Dynamic	Priority Scan:	Inactive

[Stop Scan](#)

New Scan

Scan Duration:*
(d:hh:mm)

Priority Duration:
(d:hh:mm)

Total Devices

* Required

[Start Scan](#)

Scan Duration

Enter how long this Envoy should scan for new devices. Maximum is 7 days.

Priority Duration

If a priority duration is entered, Envoy will make device scanning its only activity for the specified amount of time. No power production data will be retrieved until the priority duration has ended.

Total Devices

If a total device number is entered, Envoy will stop scanning once the total device inventory equals this number.

© 2007-2011, [e] Enphase Energy, Inc. All rights reserved. | [Licenses](#)

- Although optional, it is **best practice** to enter a value for **Total Devices**. Enter a value in this field. The Envoy will stop scanning once it has detected the given number of devices.



NOTE: The Total Devices option can be used in conjunction with the Priority Duration option to help discover any last few microinverters at a large site.

- Enter a **Priority Duration** (optional) in days:hours:minutes (e.g., 0:00:20 to indicate zero days, zero hours, and 20 minutes). If you enter a value in this field, the Envoy will make scanning its sole activity for the period specified.



NOTE: The Priority Duration option should only be used in limited situations, e.g., at large sites or sites experiencing problems discovering devices with the normal scan.

- Click Start Scan to complete this task. The LCD panel will read:

Priority Scan
Is Active



NOTE: No power production data will be collected or displayed on the Envoy or in Enlighten while Priority Scan is active. Also, the Communication Check function will not operate during this period.



Set the Time Zone

If you do not have an Internet connection to the Envoy, you may want to set the local time zone on your Envoy.

To set the Envoy time zone:

1. From the Admin menu, choose **Date, Time, Time Zone**.
2. Under **Time Zone Setting**, select a time zone from the **Select Time Zone** drop down menu.
3. Click **Update timezone setting** to complete this task.

Envoy Serial Number: 991032310713

enlighten

[Home](#)
[Production](#)
[Inventory](#)
[Administration](#)
Language English

System Administration > Date, Time, Time Zone

[Administration Home](#)

[Device Grid Configuration](#)

[Device Conditions and Controls](#)

[Device Scan Control](#)

[Power Meter Configuration](#)

[Environ Thermostat Configuration](#)

[Security Administration](#)

[Date, Time, Timezone](#)

[Network Connectivity](#)

NTP Setting

Use NTP to synchronize clock settings Update use NTP setting

No NTP Setting

Set Date and Time (no NTP)

Date Input format: MM/DD/YYYY

Time Update date/time settings

Time Zone Setting

Time Zone: [Current US/Pacific]

Select Time Zone ▼ Update timezone setting

NTP Server Setting

Network Time Protocol (NTP) Server Settings

Primary NTP Server

Secondary NTP Server Update NTP server settings

Status Information

© 2007-2011, [e] Enphase Energy, Inc. All rights reserved. | [Licenses](#)

Event Messages

The table below lists messages that the Envoy can produce to indicate certain conditions. These messages appear on screen when your computer is connected to the Envoy local interface.

Where message is displayed:		Description
Home Screen	Inventory Screen	
AC Frequency Changing Too Fast	AC Frequency Changing Too Fast	<p>Recommended Action: No action is required unless the condition persists.</p> <p>Description: AC frequency is the frequency at which voltage varies on the utility grid. The microinverter reports that this value is changing more rapidly than allowed. Frequency Changing Too Fast events are usually transient, and self-correcting by the utility.</p>
AC Frequency Out Of Range	AC Frequency Out Of Range	<p>Recommended Action: This condition should correct itself. No action is required.</p> <p>Description: The microinverter reports that the frequency coming from the utility is either too low or too high as specified by applicable regional standards.</p> <p>AC frequency is the frequency at which voltage varies on the utility grid. Frequency Out of Range events are usually transient and self-correcting by the utility.</p> <p>When the microinverter detects an out of frequency condition, it must remain offline until the utility has been within acceptable limits continuously for a short period of time (seconds to minutes, varies by region). If, during that time, the utility again exceeds or falls short of acceptable limits, the timer must restart and the microinverter may not begin producing power for an additional short period following the last out-of-bounds condition.</p> <p>If the condition persists: Contact your installer or refer to the Troubleshooting Guide at http://www.enphase.com/support/.</p>
AC Voltage Average High	AC Voltage Average High	<p>Recommended Action: No action is required unless the condition persists.</p> <p>Description: The microinverter reports that the average AC voltage coming from the utility over the past 10 minutes was too high for the configured grid profile.</p> <p>If the condition persists: Contact your installer or refer to the Troubleshooting Guide at http://www.enphase.com/support/.</p>

Where message is displayed:		Description
Home Screen	Inventory Screen	
AC Voltage Out Of Range	AC Voltage Out Of Range	<p>Recommended Action: This condition should correct itself. No action is required.</p> <p>Description: The microinverter reports that the AC voltage coming from the utility is either too low or too high as specified by applicable regional standards.</p> <p>When the microinverter detects a voltage out of range condition, it must remain offline until the utility has been within acceptable limits continuously for a short period of time (several minutes, varies by region). If, during those several minutes the utility again exceeds or falls short of acceptable limits, the timer must restart and the microinverter may not begin producing power for an additional short period following the last out-of-bounds condition.</p> <p>If the condition persists: contact your installer or refer to the Troubleshooting Guide at http://www.enphase.com/support/.</p>
Applying grid profile xx from regulatory specification yy		<p>Description: The Envoy has started a change to the grid profile for the microinverters. This process may take a few minutes. No action is required.</p> <p>xx = grid profile name yy = Regional specification name.</p>
Bad Flash Image	Bad Flash Image	<p>Description: The microinverter is not producing power due to a software problem.</p> <p>For assistance, contact Enphase Energy customer support.</p>
Commanded Reset	Commanded Reset	<p>Recommended Action: No action is required; it will automatically resume normal operation momentarily.</p> <p>Description: The microinverter was reset, either following a successful software download or by user command.</p>
Control Request		<p>Description: The Envoy has received a control request made via the Envoy interface (Administration > Device Conditions and Controls page) or via Enlighten.</p> <p>This uncommon condition will occur only during isolated troubleshooting procedures by Enphase personnel. No action is required.</p>
Critical Temperature	Critical Temperature	<p>Recommended Action: This condition should correct itself. No action is required.</p> <p>Description: This rare condition occurs if the microinverter reports an internal temperature that exceeds its rated range. It reacts by producing less power to reduce internal temperature. Once the internal temperature of the microinverter diminishes, it will resume full power production and this error message will clear.</p> <p>If the condition persists: contact your installer or refer to the Troubleshooting Guide at http://www.enphase.com/support/.</p>

Where message is displayed:		Description
Home Screen	Inventory Screen	
DC Resistance Low	DC Resistance Low	<p>Recommended Action: No action is required unless the condition persists.</p> <p>Description: A sensor in the microinverter measures the resistance between the positive and negative PV inputs and ground. If either resistance drops below a threshold, the microinverter raises this condition. This may indicate issues due to moisture, overload, defective circuit, live wires making contact with ground wire, etc.</p> <p>If the condition persists: contact your installer or refer to the Troubleshooting Guide at http://www.enphase.com/support/.</p>
DC Voltage Too High	DC Voltage Too High	<p>Recommended Action: Ask your installer to check that the PV module and microinverter are compatible. It may be that the PV module generates a higher voltage than is recommended for the microinverter. Your installer may refer to the Module Compatibility List for more information: http://www.enphase.com/support/.</p> <p>Description: The microinverter reports that DC input voltage from the PV module is too high.</p> <p>If the condition persists: If the PV module is compatible and the condition persists, contact your installer or refer to the Troubleshooting Guide at http://www.enphase.com/support/.</p>
DC Voltage Too Low	DC Voltage Too Low	<p>Recommended action: This is usually a normal condition during hours of low light and at dawn and dusk.</p> <p>Description: The microinverter reports that DC input voltage from the PV module is too low. If this condition does not clear during hours of full daylight, the microinverters may be shaded or covered by snow.</p> <p>If the condition persists: If this event occurs during full daylight or if the condition persists, contact your installer or refer to the Troubleshooting Guide at http://www.enphase.com/support/.</p> <p>If this event occurs and clears daily or often during hours of full daylight, check that the PV module and microinverter are compatible. Refer to the Module Compatibility List for more information: http://www.enphase.com/support/.</p>
Download to module begun		<p>Description: The Envoy has started a software upgrade to the indicated microinverter.</p> <p>This process may take a few minutes. No action is required.</p>
Download to module ended		<p>Description: The Envoy has successfully delivered a software upgrade to a microinverter.</p> <p>No action is required.</p>
Download to module failed		<p>Description: The Envoy was unable to successfully deliver a software upgrade to a microinverter.</p> <p>No action is required; the Envoy will repeat the attempt.</p>

Where message is displayed:		Description
Home Screen	Inventory Screen	
Envoy Failure		<p>Recommended Action: Unplug the Envoy from the electrical outlet and plug it in once again. Leave it plugged in and in place for at least 15 minutes.</p> <p>Description: This message displays after the Envoy has tried unsuccessfully three times to start up.</p> <p>This condition does not affect your system’s ability to produce power, and when the connection is restored, the Envoy will catch up with the transmission of any/all energy data it has stored.</p> <p>If the condition persists: If the Envoy continues to display Gateway (or Envoy) Failure or if it never moves beyond the Initialization stage, contact your installer or refer to the Troubleshooting Guide at http://www.enphase.com/support/.</p>
Filesystem integrity audit failed		<p>Description: The Envoy file system integrity audit has failed.</p> <p>For assistance, contact Enphase Energy customer support.</p>
GFI Tripped	gfi-tripped	<p>Recommended Action: To clear this error using the Envoy interface, follow the directions on page 31. After being reset, the condition should clear unless conditions causing the event have not been remedied or if the failure is permanent.</p> <p>Description: A microinverter has detected ground fault current greater than one amp on the DC side.</p> <p>The GFI sensor in the microinverter detects changes in electrical current by measuring the amps traveling through a circuit and quickly opens (breaks) the circuit when there is a small loss or ground fault. These losses or ground faults can be due to moisture, overload, defective circuit, live wires making contact with ground wire, etc.</p> <p>If the condition persists: If GFI events persist after clearing the condition from the Envoy, contact your installer or refer to the Troubleshooting Guide at http://www.enphase.com/support/</p> <p>For further assistance, contact Enphase Energy customer support at 877-797-4743 or at support@enphase.com.</p>
Grid Gone	Grid Gone	<p>Recommended Action: In most cases no action is required. If there is a power outage in your area and the system has stopped production, solar production will resume when the utility restores power to your area. Verify that the circuit breaker(s) for the PV array are ON at the load center. If all breaker(s) are on, the condition should clear itself.</p> <p>Description: The microinverter detects no power coming from the local Utility.</p> <p>Enphase microinverters are “utility interactive” and require a connection to the utility.</p> <p>If the condition persists: If Grid Gone events persist, contact your installer or refer to the Troubleshooting Guide at http://www.enphase.com/support/.</p>

Where message is displayed:		Description
Home Screen	Inventory Screen	
Grid Instability	Grid Instability	<p>Description: The microinverter is not producing power due to one or more of these conditions: AC Frequency Out Of Range, AC Voltage Out Of Range, or Grid Gone. Note that Grid Instability will remain for about five minutes after the underlying conditions clear. No power is produced during this time.</p> <p>No action is required unless the condition persists. If it persists, contact Enphase Energy customer support.</p>
Grid Offset Hi	Grid Offset Hi	<p>Recommended Action: No action is required unless the condition persists.</p> <p>Description: The average current to the grid is too high for the configured grid profile.</p> <p>When the microinverter is operating normally, no DC current is injected into the grid. If the DC current is too high, this may indicate an issue with the microinverter.</p> <p>If the condition persists: contact your installer or refer to the Troubleshooting Guide at http://www.enphase.com/support/.</p>
Grid Offset Low	Grid Offset Low	<p>Recommended Action: No action is required unless the condition persists.</p> <p>Description: The average current to the grid is too low for the configured grid profile.</p> <p>When the microinverter is operating normally, no DC current is injected into the grid. If the DC current is too low (negative), this may indicate an issue with the microinverter.</p> <p>If the condition persists: contact your installer or refer to the Troubleshooting Guide at http://www.enphase.com/support/.</p>
Grid profile application completed		<p>Description: The Envoy has completed a change to the grid profile for the microinverters. No action is required.</p>
Module added		<p>Description: The Envoy has detected and is now associated to a new microinverter.</p> <p>No action is required.</p>

Where message is displayed:		Description
Home Screen	Inventory Screen	
Microinverter failed to report	Failed to report	<p>Recommended Action: You can ignore occasional instances of this error. Communications will likely recover on the next reporting cycle.</p> <p>If communications do not recover immediately, make sure that the Envoy is plugged in very near to the load center. Also, if other devices are sharing the receptacle with the Envoy, remove those devices to improve communication signal strength.</p> <p>If the Enphase Envoy was recently relocated or if new devices or appliances were added to the circuit, it is possible that the new situation is not suitable for power line communication. The Envoy may need to be relocated to improve signal strength, and reduce interfering noise on the power lines.</p> <p>To determine the quality of the Envoy's location for communication, please run a Communication Check by holding down the Envoy's menu button until the LCD display reads "Enable Communication Check" and then release the menu button. The Envoy will then broadcast a signal to the microinverters and within 5 minutes a "Comm Level" indication of 0 to 5 bars will display on the Envoy LCD display. The Envoy requires a minimum of 3 bars to communicate effectively with the microinverters.</p> <p>Description: The Envoy reporting this condition is unable to communicate with the microinverters over the power lines.</p> <p>If the condition persists: See Power Line Communication Troubleshooting on page 26, or contact your installer, or refer to the Troubleshooting Guide at http://www.enphase.com/support/.</p>
Microinverter grid configuration failed after 5 attempts, retrying		<p>Description: The attempt to change the grid profile for the microinverters has failed after five tries. The Envoy will continue to attempt to change the grid profile. No action is required.</p>
Microinverter grid configuration failure cleared after xx attempts		<p>Description: A failed attempt to change the grid profile for the microinverters has cleared. The grid profile was successfully applied to the microinverters. No action is required.</p> <p>xx = number of attempts</p>
Module Sleeping	Sleeping	<p>Description: The Microinverter is off for the night.</p> <p>No action is required.</p>
No Grid Profile	No Grid Profile	<p>Recommended Action: Use the Envoy Gateway web interface to select a grid profile for this system. For more information refer to "Manage Grid Profile" on page 31.</p> <p>Description: The Envoy has not been set up with a grid profile for the microinverters.</p>

Where message is displayed:		Description
Home Screen	Inventory Screen	
Over Temperature	Over Temperature	<p>Description: The microinverter is too hot and is not producing power.</p> <p>This very rare condition usually clears without intervention. No action is required unless the condition persists. If it persists, contact Enphase Energy customer support.</p>
Power generation off by command	Power generation off by command	<p>Description: The microinverter is not producing power by user command.</p> <p>This uncommon condition will occur only during isolated troubleshooting procedures by Enphase personnel. No action is required.</p>
Power On Reset	Power On Reset	<p>Description: The microinverter has powered on after having both AC and DC disconnected.</p> <p>No action is required.</p>
Shutdown		<p>Description: The Envoy has been powered down (unplugged from AC power).</p> <p>Restore AC power to the Envoy.</p>
Skipped Cycles	Skipped Cycles	<p>Description: The microinverter has not produced power for more than 5% of the most recent production cycle; this may be due to real problems in the grid or a hardware failure of the microinverter.</p> <p>If the condition persists, contact Enphase Energy customer support.</p>
Startup		<p>Description: The Envoy has been powered back up (plugged back in to AC power).</p> <p>No action is required.</p>
Transient Grid Profile	Transient Grid Profile	<p>Recommended Action: No action is required. This condition will clear once the grid profile test is complete.</p> <p>Description: This system is currently in test mode.</p>

Technical Data

Communications Interface	
Power line	Enphase proprietary
Ethernet	10/100 auto-sensing, auto-negotiation
USB (one or two ports, depending on Envoy model)	USB 2.0 interface, auto-sensing, auto-negotiation
Power Requirements	
AC outlet	120 VAC, 60 Hz
Power consumption	2.5 watts typical, 7 watts maximum
Mechanical Data	
Dimensions (WxHxD)	8.8" x 4.4" x 1.7" (222.5 mm x 112mm x 43.2mm)
Weight	12 oz (340g)
Ambient temperature range	-40°C to +65°C (-40° to 149°F)
Cooling	Natural convection – no fans
Enclosure environmental rating	Indoor - NEMA 1
Features	
Standard warranty term	1 year
Compliance	UL 60950, EN 60950, FCC Part 15 Class B

Appendix A

Limited Warranty

Enphase Energy Inc. ("**Enphase**") has developed a highly reliable Envoy Communications Gateway that is designed to withstand normal operating conditions when used for its originally intended purpose in compliance with the Enphase User Manual supplied with the originally shipped system. The Enphase limited warranty ("**Limited Warranty**") covers defects in workmanship and materials of the Envoy Communications Gateway ("**Defective Product**") for a period of one (1) year from the date of original purchase of such Envoy Communications Gateway at point of sale to the originally-installed end user location (the "**Warranty Period**"). During the Warranty Period, the warranty is transferable to a different owner as long as the Envoy Communications Gateway remains installed at the originally-installed end user location.

During the Warranty Period, Enphase will, at its option, repair or replace the Defective Product free of charge, provided that Enphase through inspection establishes the existence of a defect that is covered by the Limited Warranty. Enphase will, at its option, use new and/or reconditioned parts in repairing or replacing the Defective Product. Enphase reserves the right to use parts or products of original or improved design in the repair or replacement of Defective Product. If Enphase repairs or replaces a Defective Product, the Limited Warranty continues on the repaired or replacement product for the remainder of the original Warranty Period or ninety (90) days from the date of Enphase's return shipment of the repaired or replacement product, whichever is later.

The Limited Warranty covers both parts and labor necessary to repair the Defective Product, but does not include labor costs related to un-installing the Defective Product or re-installing the repaired or replacement product. The Limited Warranty also covers the costs of shipping repaired or replacement product from Enphase, via a non-expedited freight carrier selected by Enphase, to locations within the United States (including Alaska and Hawaii) and Canada, but not to other locations outside the United States or Canada. The Limited Warranty does not cover, and Enphase will not be responsible for, shipping damage or damage caused by mishandling by the freight carrier and any such damage is the responsibility of the freight carrier.

To obtain repair or replacement service under this Limited Warranty, the customer must comply with the following policy and procedure:

- All Defective Product must be returned with a Return Merchandise Authorization Number (RMA) which customer must request from Enphase. Before requesting the RMA, however, the customer should contact an Enphase technical support representative to evaluate and troubleshoot the problem while the Envoy Communications Gateway is in the field, since many problems can be solved in the field.
- If in-field troubleshooting does not solve the problem, Customer may request the RMA number, which request must include the following information:
 - Proof-of-purchase of the Defective Product in the form of (1) the dated purchase receipt from the original purchase of the product at point of sale to the end user, or (2) the dated dealer invoice or purchase receipt showing original equipment manufacturer (OEM) status, or (3) the dated invoice or purchase receipt showing the product exchanged under warranty
 - Model number of the Defective Product.
 - Serial number of the Defective Product.

- Detailed description of the defect.
 - Shipping address for return of the repaired or replacement product.
-
- All Defective Product authorized for return must be returned in the original shipping container or other packaging that is equally protective of the product.
 - The returned Defective Product must not have been disassembled or modified without the prior written authorization of Enphase.

The Enphase Envoy Communications Gateways are designed to withstand normal operating conditions and typical wear and tear when used for their original intent and in compliance with the installation and operating instructions supplied with the original equipment. The Limited Warranty does not apply to, and Enphase will not be responsible for, any defect in or damage to any Enphase Envoy Communications Gateway: (1) that has been misused, neglected, tampered with, altered, or otherwise damaged, either internally or externally; (2) that has been improperly installed, operated, handled or used, including use under conditions for which the product was not designed, use in an unsuitable environment, or use in a manner contrary to the Enphase User Manual or applicable laws or regulations; (3) that has been subjected to fire, water, generalized corrosion, biological infestations, acts of God, or input voltage that creates operating conditions beyond the maximum or minimum limits listed in the Enphase Envoy Communications Gateway specifications, including high input voltage from generators or lightning strikes; (4) that has been subjected to incidental or consequential damage caused by defects of other components of the solar system; or (5) if the original identification markings (including trademark or serial number) of such Envoy Communications Gateway have been defaced, altered, or removed. The Limited Warranty does not cover costs related to the removal, installation or troubleshooting of the customer's electrical systems. The Limited Warranty does not extend beyond the original cost of the Enphase Envoy Communications Gateway.

THE LIMITED WARRANTY IS THE SOLE AND EXCLUSIVE WARRANTY GIVEN BY ENPHASE AND, WHERE PERMITTED BY LAW, IS MADE EXPRESSLY IN LIEU OF ALL OTHER WARRANTIES, EXPRESS OR IMPLIED, STATUTORY OR OTHERWISE, INCLUDING, WITHOUT LIMITATION, WARRANTIES OF TITLE, QUALITY, MERCHANTABILITY, FITNESS FOR A PARTICULAR PURPOSE OR NON-INFRINGEMENT OR WARRANTIES AS TO THE ACCURACY, SUFFICIENCY OR SUITABILITY OF ANY TECHNICAL OR OTHER INFORMATION PROVIDED IN MANUALS OR OTHER DOCUMENTATION. IN NO EVENT WILL ENPHASE BE LIABLE FOR ANY SPECIAL, DIRECT, INDIRECT, INCIDENTAL OR CONSEQUENTIAL DAMAGES, LOSSES, COSTS OR EXPENSES HOWEVER ARISING, WHETHER IN CONTRACT OR TORT, INCLUDING WITHOUT LIMITATION ANY ECONOMIC LOSSES OF ANY KIND, ANY LOSS OR DAMAGE TO PROPERTY, OR ANY PERSONAL INJURY.

To the extent any implied warranties are required under applicable law to apply to the Envoy Communications Gateway, such implied warranties shall be limited in duration to the Warranty Period, to the extent permitted by applicable law. Some states and provinces do not allow limitations or exclusions on implied warranties or on the duration of an implied warranty or on the limitation or exclusion of incidental or consequential damages, so the above limitation(s) or exclusion(s) may not apply. This Limited Warranty gives the customer specific legal rights, and the customer may have other rights that may vary from state to state or province to province.





Enphase Energy Inc.

201 1st Street

Petaluma, CA 94952

Phone: 707-763-4784

TOLL FREE: 877-797-4743

Fax: 707-763-0784

www.enphase.com

info@enphaseenergy.com