

**PowerLite® Pro
G5450WUNL/G5550NL/
G5650WNL/G5750WUNL/
G5950NL Multimedia Projector**

User's Guide

Important Safety Information

WARNING: Never look into the projector lens when the lamp is turned on; the bright light can damage your eyes. Never let children look into the lens when it is on. Never open any cover on the projector, except the lamp and filter covers. Dangerous electrical voltages inside the projector can severely injure you. Except as specifically explained in this *User's Guide*, do not attempt to service this product yourself. Refer all servicing to qualified service personnel.

WARNING: The projector and its accessories come packaged in plastic bags. Keep plastic bags away from small children to avoid any risk of suffocation.

Caution: When you replace the lamp, never touch the new lamp with your bare hands; the invisible residue left by the oil on your hands may shorten the lamp life. Use a cloth or glove to handle the new lamp.

Copyright Notice

All rights reserved. No part of this publication may be reproduced, stored in a retrieval system, or transmitted in any form or by any means, electronic, mechanical, photocopying, recording, or otherwise, without the prior written permission of Seiko Epson Corporation. The information contained herein is designed only for use with this Epson product. Epson is not responsible for any use of this information as applied to other products.

Neither Seiko Epson Corporation nor its affiliates shall be liable to the purchaser of this product or third parties for damages, losses, costs, or expenses incurred by purchaser or third parties as a result of: accident, misuse, or abuse of this product or unauthorized modifications, repairs, or alterations to this product, or (excluding the U.S.) failure to strictly comply with Seiko Epson Corporation's operating and maintenance instructions.

Seiko Epson Corporation shall not be liable for any damages or problems arising from the use of any options or any consumable products other than those designated as Original Epson Products or Epson Approved Products by Seiko Epson Corporation.

Trademarks

Epson, Quick Corner, EasyMP, and Instant Off are registered trademarks, and Epson Exceed Your Vision is a registered logomark of Seiko Epson Corporation.

PowerLite and PrivateLine are registered trademarks; SizeWise is a trademark; and Extra Care is a service mark of Epson America, Inc.

Pixelworks and DNX are trademarks of Pixelworks, Inc.

HDMI and High-Definition Multimedia Interface are registered trademarks of HDMI Licensing, LLC.



This product includes RSA BSAFE™ software from RSA Security Inc. RSA is a registered trademark of RSA Security Inc. BSAFE RSA Security Inc. is a registered trademark in the United States and other countries.

This product includes **NetNucleus**® **WPA** software from TOSHIBA INFORMATION SYSTEMS CORPORATION.

NetNucleus is a registered trademark of TOSHIBA INFORMATION SYSTEMS CORPORATION in Japan.

WPA™, WPA2™, and Wi-Fi Protected Setup are registered trademarks of the Wi-Fi Alliance.

General Notice: Other product names used herein are for identification purposes only and may be trademarks of their respective owners. Epson disclaims any and all rights in those marks.

This information is subject to change without notice.

C

Contents

<i>Welcome</i>	11
Using Your Documentation	13
Getting More Information	13
Registration and Warranty	14
Optional Accessories	15

1

<i>Setting Up the Projector</i>	17
Unpacking the Projector	18
Additional Components	18
Positioning the Projector	19
Connecting to a Computer	30
Connecting to the DVI-D Port (G5450WUNL/ G5750WUNL only)	31
Connecting a DVI-D Source to the HDMI Port	32
Connecting to the HDMI Port	33
Connecting to the Computer Port	34
Connecting to the BNC Connectors	35
Connecting to Video Equipment	36
Connecting an HDMI Video Source	37
Connecting a DVI-D Video Source to the DVI-D Port (G5450WUNL/G5750WUNL only)	38
Connecting a DVI-D Video Source to the HDMI Port	39
Connecting a Composite Video Source	40
Connecting an S-Video Source	41
Connecting a Component Video Source	42
Connecting an RGB Video Source	43
Connecting an External Monitor	45
Playing Sound Through the Projector	46
Connecting External Speakers	49

Connecting to a Digital Camera or Other USB Device	50
Removing the USB Device or Cable	51
Turning the Projector On and Off	51
Using the Direct Power On Function	53
Shutting Down the Projector	54

2 <i>Displaying and Adjusting the Image</i>	55
Displaying an Image	56
Adjusting the Image	56
Adjusting the Position of the Image	57
Focusing and Zooming the Image	58
Adjusting the Image Shape	58
Selecting the Color Mode	60
Resizing Video Images	61
Projecting Two Images Simultaneously	62

3 <i>Presenting With the Remote Control</i>	65
Using the Remote Control	66
Controlling the Picture and Sound	66
Switching Between Picture Sources	66
Turning Off the Picture and Sound	67
Stopping Action	67
Zooming Part of Your Image	68
Controlling the Volume	68
Highlighting Your Presentation	69
Using the Pointer Tool	69
Choosing a Different Pointer Shape	69
Operating Your Computer With the Remote Control	70
Operating Two or More Projectors With the Remote Control	71
Setting the Projector ID	71
Checking the Projector ID	72
Setting the Remote Control ID	72

4 <i>Using the Projector on a Network</i>	75
Connecting to a Wired Network	76
Installing the Optional Wireless 802.11g/b/a Module	78

Using Quick Wireless Connection	79
Configuring Basic Settings	80
Configuring a Wireless Connection	81
Configuring the Projector	82
Selecting Wireless Network Settings in Windows.	84
Selecting Wireless Network Settings in Mac OS.	85
Making a WPS (Wi-Fi Protected Setup) Connection.	85
Using Wireless Security Options.	90
Enabling WEP Encryption.	91
Enabling WPA Security	93
Enabling EAP, LEAP, or PEAP Authentication	94
Enabling EAP-TLS Certificate Validation	95
Enabling Data Encryption from EasyMP Network Projection	96
Using the EasyMP Network Projection Software	96
Removing the Wireless 802.11g/b/a Module	97
Using Projector E-mail Alerts	98
Using SNMP to Monitor the Projector.	100
Using a Browser to Control the Projector.	101
Using Web Remote Control.	102
Using Crestron RoomView to Monitor and Control the Projector	104
Setting up the Projector	104
Using a Browser to Control the Projector.	105
5 <i>Fine-Tuning the Projector</i>	111
Using the Menu System	112
Restoring the Default Settings	113
Adjusting the Image	114
Six-Axis Color Adjustment.	115
Adjusting Signal Settings	116
Customizing Projector Features	119
Using the Projector Security Features	121
Enabling Password Protection	121
Creating Your Own Startup Screen	123
Disabling the Projector's Buttons.	125
Customizing Power and Operation.	126
Multi-screen Color Adjustment	128

Projector Menu and Options List	129
---	-----

6 <i>Maintaining the Projector</i>	133
Cleaning the Lens	134
Cleaning the Projector Case	134
Cleaning the Air Filter	134
Replacing the Air Filter	137
Replacing the Lamp	138
Resetting the Lamp Timer	141
Checking Lamp Usage	142
Replacing the Batteries	142
Transporting the Projector	143

7 <i>Solving Problems</i>	145
Using On-Screen Help	146
Checking Projector Status	147
What To Do When the Lights Flash	147
Solving Projector Operation Problems	149
Solving Problems With the Image or Sound	150
Solving Network Problems	157
Solving Problems With the Remote Control	160
Where to Get Help	161
Internet Support	161
Speak to a Support Representative	161
Purchase Supplies and Accessories	162

A <i>Projector Installation</i>	163
Installation Guidelines	163
Security Features	164
Installing and Removing the Cable Cover	165
Installing and Removing the Lens	166
Installing the Lens	166
Removing the Lens	167

B	<i>Technical Specifications</i>	169
C	<i>Notices</i>	179
	Important Safety Instructions	179
	FCC Compliance Statement	183
	Software Copyright	184
	<i>Index</i>	211

W

Welcome

The PowerLite® Pro G5450WUNL/G5550NL/G5650WNL/G5750WUNL/G5950NL is an easy-to-use, lightweight projector. It offers up to 4000 lumens (G5450WUNL), 4500 lumens (G5550NL/G5650WNL/G5750WUNL), or 5200 lumens (G5950NL) of brightness, and provides a native XGA (G5550NL/G5950NL), WXGA (G5650WNL), or WUXGA (G5450WUNL/G5750WUNL) resolution. You can connect it to a wide range of computers and video sources. You can project from a USB storage device, or over a wired network. With the optional Wireless 802.11g/b/a Module, you can also project over an 802.11g, 802.11b, or 802.11a wireless network.

Your projector offers these easy setup, control, and security features:

- Manual horizontal and vertical lens shift
- Centered lens design
- Instant Off® feature for fast setup and shut down
- Quick Corner® for easy image shape/size adjustment
- Optical zoom lens for flexible placement and positioning (lens not included)
- 5 optional bayonet lenses
- One-touch filter replacement
- Side-loading easy lamp access
- Security features include password, user's logo, the ability to lock the projector buttons, a security cable attachment (cable not included), a slot for an optional Kensington® security lock, and a lens theft deterrent screw

Additional enhancements:

- Crestron RoomView® compatibility
- A Message Broadcasting plug-in that allows you to project timely alerts and messages to all networked projectors (to download both the plug-in and its instructions, visit Epson's support website at www.epson.com/support (U.S.) or www.epson.ca/support (Canada) and select your product).
- Closed captioning for the hearing impaired
- HDMI for digital connectivity (HDCP compatible)
- DVI-D for digital connectivity (G5450WUNL/G5750WUNL only, HDCP compatible)
- 2000:1 (G5650WNL/G5950NL), 1500:1 (G5750WUNL), or 1000:1 (G5450WUNL/G5550NL) contrast ratio
- Color match images from two or more projectors for a uniform, wide-screen view
- When you present with PowerPoint®, project only the slide images while viewing handout notes and controls on the computer screen
- Perform six-axis color adjustment for fine art and photography
- Project two images simultaneously using the projector's split screen feature
- Project images from different networked computers simultaneously using the EasyMP Multi PC Projection software
- Project X-ray photographs and other medical images using DICOM SIM Color Mode
- Choose between four different test patterns to use when adjusting the projector image

note

The projector is not a medical device and cannot be used for medical diagnosis.

Using Your Documentation

Please follow these guidelines as you read through this manual:

- Warnings must be followed carefully to avoid bodily injury.
- Cautions must be observed to avoid damage to your equipment.
- Notes contain important information about your projector.
- Tips contain additional projection hints.

Getting More Information

Need tips on giving presentations? Quick steps for setting up your projector? Here's where you can look for help:

- **Quick Reference card**
Provides information for connecting the projector to your equipment, displaying and adjusting the image, using the remote control, and solving display problems.
- **EasyMP Network Projection Operation Guide**
Provides detailed instructions on using your projector in a network environment (installed along with this manual from the projector CD). To set up your projector for the first time on a network, see page 75 of this User's Guide.
- **EasyMP Multi PC Projection Operation Guide**
Provides instructions on using the EasyMP Multi PC Projection software to simultaneously display images from different networked computers (installed along with this manual from the projector CD).
- **EasyMP Monitor Operation Guide**
Provides instructions on using the EasyMP Monitor software (available for Windows only) to manage projectors on a network. To view the guide, double-click the icon on your computer's desktop. To download the software, double-click the **Download EasyMP Monitor** icon on your computer's desktop.

note

In some cases, the illustrations in this guide may not exactly match your projector.

- ***PC Free Operation Guide***
Provides instructions on projecting files from a USB storage device or digital camera that is connected to the projector (installed along with this manual from the projector CD).
- ***EasyMP Slide Converter Operation Guide***
Provides instructions on using the EasyMP Slide Converter software to convert and transfer presentations to a USB storage device so that you can present without using a computer (installed along with this manual from the projector CD).
- **Built-in help system**
Provides assistance for common problems. Available from the **Help** button on the projector or the remote control. See page 146 for details.
- **epson.com/support (U.S.) or epson.ca/support (Canada)**
Download FAQs and e-mail your questions to Epson support.
- **PrivateLine® support**
If you still need help after checking this *User's Guide* and the sources listed in this section, you can use the Epson PrivateLine Support service to get help fast. Call (800) 637-7661 and enter the PIN on the PrivateLine card. See page 161 for more information.

Registration and Warranty

Your projector comes with a basic warranty that lets you project with confidence. For details, see the warranty brochure included with your projector.

In addition, Epson offers free Extra CareSM Road Service. In the unlikely event of an equipment failure, you won't have to wait for your unit to be repaired. Instead, Epson will ship you a replacement unit anywhere in the United States, Canada, or Puerto Rico. See the brochure included with your projector for details.

Register online using your projector CD or at epson.com/webreg. Registering also lets you receive special updates on new accessories, products, and services.

Optional Accessories

To enhance your use of the projector, Epson offers the following optional accessories:

Product	Part number
Replacement lamp for PowerLite Pro G5450WUNL/G5550NL	V13H010L62
Replacement lamp for PowerLite Pro G5650WNL/G5750WUNL/G5950NL	V13H010L63
Replacement air filter	V13H134A17
Standard Zoom Lens <1.64 - 2.5>	V12H004S05
Middle Throw Zoom Lens 1 <1.83 - 2.45>	V12H004M04
Middle Throw Zoom Lens 2 <1.83 - 2.53>	V12H004M05
Long Throw Zoom Lens <1.84 - 2.32>	V12H004L06
Rear Projection Wide Lens <2.03>	V12H004R03
Wireless 802.11g/b/a Module	V12H306P11
Quick Connect Wireless Key	ELPAP08
Wireless IR Mouse Receiver for Remote Control	V12H007T16
Hardwire Remote Control Cable Set	V12H005C28
Replacement remote control	1531179
Advanced projector ceiling mount with precision gear	ELPMBPRG
Adjustable suspended ceiling channel kit	ELPMBP01
False ceiling plate kit	ELPMBP02
Structural round ceiling plate	ELPMBP03
Adjustable extension column (pipe) 8"–11"	ELPMBC01
Kensington® MicroSaver® security lock	ELPSL01
ES3000 Ultra Portable Projector Screen	V12H002S3Y
50-inch portable screen (4:3 aspect ratio)	ELPSC06
DUET™ portable projector screen	ELPSC80
Component-to-VGA video cable	ELPKC19
Distribution amplifier	ELPDA01
DC-10s document camera	ELPDC10S
1-Year Extended Depot Repair Service Plan	EPPFTP1
1-Year Extended Exchange Warranty	EPPEXP1
2-Year Extended Depot Repair Service Plan	EPPFTP2

You can purchase screens or other accessories from an Epson authorized reseller. To find the nearest reseller, call 800-GO-EPSON (800-463-7766). Or you can purchase online at www.epsonstore.com (U.S. sales) or www.epson.ca (Canadian sales).

1 *Setting Up the Projector*

This chapter tells you how to unpack the projector and connect it to a notebook or desktop computer, to video equipment, such as a Blu-ray Disc™/DVD player, digital tuner, cable or satellite box, video game console, camcorder, or digital camera, and/or to your local area network.

You can also connect the projector to a USB storage device or digital camera.

Follow the instructions in this chapter on:

- Unpacking the projector
- Positioning the projector
- Connecting to a computer
- Connecting to video equipment
- Connecting an external monitor
- Playing sound through the projector
- Connecting to a digital camera or other USB device
- Turning the projector on and off

Unpacking the Projector

After unpacking the projector, make sure you have all these parts:

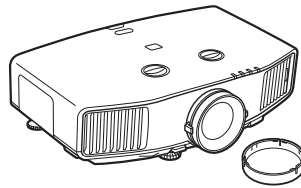

Projector and lens cap

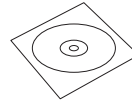

PDF manuals and registration CD-ROM

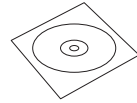

Projector software CD-ROM

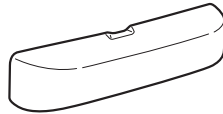

Cable cover

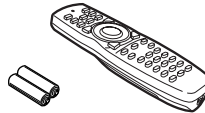

Remote control and 2 AA batteries



Password Protected sticker

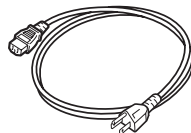

Power cord

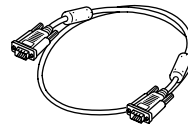

VGA computer cable

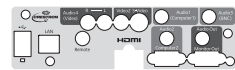

Interface label stickers

note

If you mount the projector on the ceiling, the interface and button names on the projector will appear upside down. Attach the interface label stickers so that you can more easily read the names.

Save all packaging in case you need to ship the projector. Always use the original packaging (or the equivalent) when you need to send the projector to another location. If you are moving the projector by hand, use the projector handle. See page 143 for transportation instructions.

Additional Components

Depending on how you plan to use the projector, you may need additional components:

- To receive an HDMI signal from your video device, you'll need an HDMI cable. One may be provided with your video equipment.
- To receive a DVI-D video signal from your video device, you'll need a DVI cable (G5450WUNL/G5750WUNL only) or DVI/HDMI conversion cable.

- To receive a component video signal from your video device, you'll need a component video cable. One may be provided with your video equipment.
- To receive an RGB or component video signal from a video device that has RGB or component (PrPbY or CrCbY) connectors, you'll need a BNC-type video cable. One may be provided with your video equipment.
- To receive an S-Video signal, you'll need an S-Video cable. One may be provided with your video equipment.

Positioning the Projector

If the projector isn't already installed in the room you're using, you'll probably want to place it on a table in front of the screen. This lets you stand in the front of the room, face the audience, and remain close enough to the equipment to be able to control it. Try to leave as much space as possible between the projector and the screen to get a good-size image.

Use the illustrations and tables below to help you determine placement. Image size increases with distance, but can vary depending on which lens you're using and whether you've adjusted the image with vertical lens shift, zoom, or any other settings.

You can also use the [Image Size Calculator](#) on the Epson website.

note

You can mount the projector on the ceiling, or place it behind a translucent screen for rear projection. See page 163 for details.

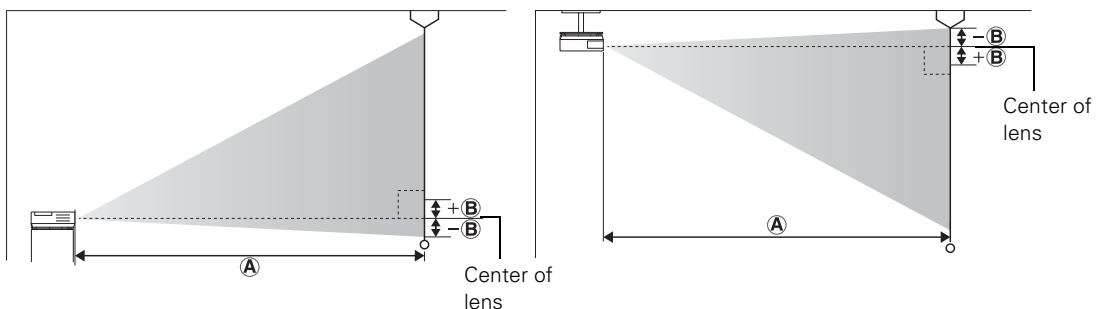

**PowerLite Pro G5450WUNL/G5750WUNL, 16:10 image,
Standard zoom lens (part number V12H004S05)**

Screen size	Projection distance (A) Wide to Tele	Offset (B)
50 inches	53 to 97 inches (136 to 246 cm)	-2.2 to 28.7 inches (-6 to 73 cm)
60 inches	64 to 117 inches (164 to 296 cm)	-2.7 to 34.5 inches (-7 to 88 cm)
80 inches	87 to 156 inches (220 to 397 cm)	-3.5 to 45.9 inches (-9 to 117 cm)
100 inches	109 to 196 inches (276 to 497 cm)	-4.4 to 57.4 inches (-11 to 146 cm)
150 inches	164 to 294 inches (417 to 747 cm)	-6.6 to 86.1 inches (-17 to 219 cm)
200 inches	219 to 393 inches (557 to 998 cm)	-8.9 to 114.9 inches (-22 to 292 cm)
250 inches	275 to 491 inches (698 to 1248 cm)	-11.1 to 143.6 inches (-28 to 365 cm)
300 inches	330 to 590 inches (838 to 1499 cm)	-13.3 to 172.3 inches (-34 to 438 cm)

**PowerLite Pro G5450WUNL/G5750WUNL, 16:10 image, Middle
throw zoom lens 1 (part number V12H004M04)**

Screen size	Projection distance (A) Wide to Tele	Offset (B)
50 inches	95 to 146 inches (242 to 371 cm)	-2.2 to 28.7 inches (-6 to 73 cm)
60 inches	115 to 176 inches (292 to 447 cm)	-2.7 to 34.5 inches (-7 to 88 cm)
80 inches	155 to 236 inches (393 to 599 cm)	-3.5 to 45.9 inches (-9 to 117 cm)
100 inches	194 to 296 inches (494 to 751 cm)	-4.4 to 57.4 inches (-11 to 146 cm)

Screen size	Projection distance (A) Wide to Tele	Offset (B)
150 inches	294 to 446 inches (746 to 1132 cm)	-6.6 to 86.1 inches (-17 to 219 cm)
200 inches	393 to 595 inches (998 to 1512 cm)	-8.9 to 114.9 inches (-22 to 292 cm)
250 inches	492 to 745 inches (1250 to 1893 cm)	-11.1 to 143.6 inches (-28 to 365 cm)
300 inches	591 to 895 inches (1502 to 2273 cm)	-13.3 to 172.3 inches (-34 to 438 cm)

PowerLite Pro G5450WUNL/G5750WUNL, 16:10 image, Middle throw zoom lens 2 (part number V12H004M05)

Screen size	Projection distance (A) Wide to Tele	Offset (B)
50 inches	142 to 219 inches (361 to 555 cm)	-2.2 to 28.7 inches (-6 to 73 cm)
60 inches	172 to 264 inches (437 to 670 cm)	-2.7 to 34.5 inches (-7 to 88 cm)
80 inches	231 to 354 inches (588 to 898 cm)	-3.5 to 45.9 inches (-9 to 117 cm)
100 inches	291 to 444 inches (739 to 1127 cm)	-4.4 to 57.4 inches (-11 to 146 cm)
150 inches	439 to 669 inches (1116 to 1698 cm)	-6.6 to 86.1 inches (-17 to 219 cm)
200 inches	588 to 894 inches (1494 to 2270 cm)	-8.9 to 114.9 inches (-22 to 292 cm)
250 inches	737 to 1119 inches (1871 to 2841 cm)	-11.1 to 143.6 inches (-28 to 365 cm)
300 inches	885 to 1344 inches (2249 to 3413 cm)	-13.3 to 172.3 inches (-34 to 438 cm)

PowerLite Pro G5450WUNL/G5750WUNL, 16:10 image, Long throw zoom lens (part number V12H004L06)

Screen size	Projection distance (A) Wide to Tele	Offset (B)
50 inches	215 to 292 inches (546 to 742 cm)	-2.2 to 28.7 inches (-6 to 73 cm)
60 inches	259 to 352 inches (659 to 894 cm)	-2.7 to 34.5 inches (-7 to 88 cm)
80 inches	348 to 472 inches (885 to 1199 cm)	-3.5 to 45.9 inches (-9 to 117 cm)
100 inches	437 to 592 inches (1111 to 1503 cm)	-4.4 to 57.4 inches (-11 to 146 cm)
150 inches	660 to 891 inches (1675 to 2263 cm)	-6.6 to 86.1 inches (-17 to 219 cm)
200 inches	882 to 1190 inches (2240 to 3024 cm)	-8.9 to 114.9 inches (-22 to 292 cm)
250 inches	1104 to 1490 inches (2804 to 3784 cm)	-11.1 to 143.6 inches (-28 to 365 cm)
300 inches	1326 to 1789 inches (3369 to 4545 cm)	-13.3 to 172.3 inches (-34 to 438 cm)

PowerLite Pro G5450WUNL/G5750WUNL, 16:10 image, Rear projection wide lens (part number V12H004R03)

Screen size	Projection distance (A) Wide to Tele	Offset (B)
50 inches	31 inches (80 cm)	13.2 inches (34 cm)
60 inches	38 inches (96 cm)	15.9 inches (40 cm)
80 inches	51 inches (130 cm)	21.2 inches (54 cm)
100 inches	64 inches (163 cm)	26.5 inches (67 cm)
150 inches	97 inches (247 cm)	39.7 inches (101 cm)
200 inches	130 inches (330 cm)	53 inches (135 cm)

PowerLite Pro G5650WNL, 16:10 image, Standard zoom lens (part number V12H004S05)

Screen size	Projection distance (A) Wide to Tele	Offset (B)
30 inches	32 to 59 inches (81 to 149 cm)	-1.5 to 17.4 inches (-4 to 44 cm)
40 inches	43 to 79 inches (109 to 200 cm)	-2 to 23.2 inches (-5 to 59 cm)
50 inches	54 to 99 inches (138 to 251 cm)	-2.5 to 29 inches (-6 to 74 cm)
60 inches	66 to 119 inches (167 to 302 cm)	-3 to 34.8 inches (-8 to 88 cm)
80 inches	88 to 159 inches (224 to 405 cm)	-4 to 46.4 inches (-10 to 118 cm)
100 inches	111 to 200 inches (281 to 507 cm)	-5 to 58 inches (-13 to 147 cm)
150 inches	167 to 300 inches (424 to 762 cm)	-7.6 to 87.1 inches (-19 to 221 cm)
200 inches	223 to 401 inches (567 to 1018 cm)	-10.1 to 116.1 inches (-26 to 295 cm)
250 inches	280 to 501 inches (710 to 1273 cm)	-12.6 to 145.1 inches (-32 to 369 cm)
300 inches	336 to 602 inches (853 to 1529 cm)	-15.1 to 174.1 inches (-38 to 442 cm)

PowerLite Pro G5650WNL, 16:10 image, Middle throw zoom lens 1 (part number V12H004M04)

Screen size	Projection distance (A) Wide to Tele	Offset (B)
40 inches	77 to 118 inches (196 to 301 cm)	-2 to 23.2 inches (-5 to 59 cm)
50 inches	97 to 149 inches (247 to 378 cm)	-2.5 to 29.0 inches (-6 to 74 cm)
60 inches	117 to 179 inches (298 to 456 cm)	-3 to 34.8 inches (-8 to 88 cm)
80 inches	158 to 241 inches (401 to 611 cm)	-4 to 46.4 inches (-10 to 118 cm)
100 inches	198 to 302 inches (504 to 766 cm)	-5 to 58 inches (-13 to 147 cm)
150 inches	300 to 454 inches (761 to 1154 cm)	-7.6 to 87.1 inches (-19 to 221 cm)
200 inches	401 to 607 inches (1018 to 1542 cm)	-10.1 to 116.1 inches (-26 to 295 cm)
250 inches	502 to 760 inches (1275 to 1930 cm)	-12.6 to 145.1 inches (-32 to 369 cm)
300 inches	603 to 913 inches (1532 to 2318 cm)	-15.1 to 174.1 inches (-38 to 442 cm)

PowerLite Pro G5650WNL, 16:10 image, Middle throw zoom lens 2 (part number V12H004M05)

Screen size	Projection distance (A) Wide to Tele	Offset (B)
40 inches	115 to 177 inches (292 to 450 cm)	-2 to 23.2 inches (-5 to 59 cm)
50 inches	145 to 223 inches (369 to 567 cm)	-2.5 to 29.0 inches (-6 to 74 cm)
60 inches	175 to 269 inches (446 to 684 cm)	-3 to 34.8 inches (-8 to 88 cm)
80 inches	236 to 361 inches (600 to 917 cm)	-4 to 46.4 inches (-10 to 118 cm)

Screen size	Projection distance (A) Wide to Tele	Offset (B)
100 inches	297 to 453 inches (754 to 1150 cm)	-5 to 58 inches (-13 to 147 cm)
150 inches	448 to 682 inches (1139 to 1733 cm)	-7.6 to 87.1 inches (-19 to 221 cm)
200 inches	600 to 912 inches (1524 to 2316 cm)	-10.1 to 116.1 inches (-26 to 295 cm)
250 inches	751 to 1141 inches (1909 to 2899 cm)	-12.6 to 145.1 inches (-32 to 369 cm)
300 inches	903 to 1371 inches (2294 to 3482 cm)	-15.1 to 174.1 inches (-38 to 442 cm)

**PowerLite Pro G5650WNL, 16:10 image, Long throw zoom lens
(part number V12H004L06)**

Screen size	Projection distance (A) Wide to Tele	Offset (B)
40 inches	174 to 237 inches (442 to 602 cm)	-2 to 23.2 inches (-5 to 59 cm)
50 inches	219 to 298 inches (558 to 757 cm)	-2.5 to 29.0 inches (-6 to 74 cm)
60 inches	265 to 359 inches (673 to 912 cm)	-3 to 34.8 inches (-8 to 88 cm)
80 inches	355 to 481 inches (903 to 1223 cm)	-4 to 46.4 inches (-10 to 118 cm)
100 inches	446 to 603 inches (1133 to 1533 cm)	-5 to 58 inches (-13 to 147 cm)
150 inches	673 to 909 inches (1709 to 2308 cm)	-7.6 to 87.1 inches (-19 to 221 cm)
200 inches	899 to 1214 inches (2284 to 3084 cm)	-10.1 to 116.1 inches (-26 to 295 cm)
250 inches	1126 to 1519 inches (2860 to 3859 cm)	-12.6 to 145.1 inches (-32 to 369 cm)
300 inches	1352 to 1825 inches (3435 to 4635 cm)	-15.1 to 174.1 inches (-38 to 442 cm)

**PowerLite Pro G5650WNL, 16:10 image, Rear projection wide lens
(part number V12H004R03)**

Screen size	Projection distance (A) Wide to Tele	Offset (B)
30 inches	19 inches (47 cm)	7.9 inches (20 cm)
40 inches	25 inches (64 cm)	10.6 inches (27 cm)
50 inches	32 inches (81 cm)	13.2 inches (34 cm)
60 inches	39 inches (98 cm)	15.9 inches (40 cm)
80 inches	52 inches (132 cm)	21.2 inches (54 cm)
100 inches	65 inches (166 cm)	26.5 inches (67 cm)
150 inches	99 inches (251 cm)	39.7 inches (101 cm)
200 inches	132 inches (336 cm)	53 inches (135 cm)

**PowerLite Pro G5550NL/G5950NL, 4:3 image, Standard zoom
lens (part number V12H004S05)**

Screen size	Projection distance (A) Wide to Tele	Offset (B)
30 inches	30 to 56 inches (77 to 142 cm)	0 to 18 inches (0 to 46 cm)
40 inches	41 to 75 inches (104 to 190 cm)	0 to 24 inches (0 to 61 cm)
50 inches	52 to 94 inches (131 to 239 cm)	0 to 30 inches (0 to 76 cm)
60 inches	62 to 113 inches (158 to 287 cm)	0 to 36 inches (0 to 91 cm)
80 inches	84 to 151 inches (213 to 385 cm)	0 to 48 inches (0 to 122 cm)
100 inches	105 to 190 inches (267 to 482 cm)	0 to 60 inches (0 to 152 cm)

Screen size	Projection distance (A) Wide to Tele	Offset (B)
150 inches	159 to 285 inches (403 to 725 cm)	0 to 90 inches (0 to 229 cm)
200 inches	212 to 381 inches (539 to 968 cm)	0 to 120 inches (0 to 305 cm)
250 inches	266 to 477 inches (675 to 1211 cm)	0 to 150 inches (0 to 381 cm)
300 inches	319 to 572 inches (811 to 1454 cm)	0 to 180 inches (0 to 457 cm)

**PowerLite Pro G5550NL/G5950NL, 4:3 image, Middle throw
zoom lens 1 (part number V12H004M04)**

Screen size	Projection distance (A) Wide to Tele	Offset (B)
40 inches	73 to 112 inches (185 to 285 cm)	0 to 24 inches (0 to 61 cm)
50 inches	92 to 141 inches (234 to 359 cm)	0 to 30 inches (0 to 76 cm)
60 inches	111 to 170 inches (283 to 433 cm)	0 to 36 inches (0 to 91 cm)
80 inches	150 to 229 inches (380 to 581 cm)	0 to 48 inches (0 to 122 cm)
100 inches	188 to 287 inches (478 to 728 cm)	0 to 60 inches (0 to 152 cm)
150 inches	284 to 432 inches (722 to 1097 cm)	0 to 90 inches (0 to 229 cm)
200 inches	380 to 577 inches (966 to 1466 cm)	0 to 120 inches (0 to 305 cm)
250 inches	476 to 723 inches (1210 to 1835 cm)	0 to 150 inches (0 to 381 cm)
300 inches	572 to 868 inches (1454 to 2204 cm)	0 to 180 inches (0 to 457 cm)

PowerLite Pro G5550NL/G5950NL, 4:3 image, Middle throw zoom lens 2 (part number V12H004M05)

Screen size	Projection distance (A) Wide to Tele	Offset (B)
40 inches	109 to 168 inches (276 to 427 cm)	0 to 24 inches (0 to 61 cm)
50 inches	138 to 212 inches (350 to 538 cm)	0 to 30 inches (0 to 76 cm)
60 inches	166 to 256 inches (423 to 649 cm)	0 to 36 inches (0 to 91 cm)
80 inches	224 to 343 inches (569 to 871 cm)	0 to 48 inches (0 to 122 cm)
100 inches	282 to 430 inches (716 to 1093 cm)	0 to 60 inches (0 to 152 cm)
150 inches	426 to 649 inches (1082 to 1647 cm)	0 to 90 inches (0 to 229 cm)
200 inches	570 to 867 inches (1448 to 2202 cm)	0 to 120 inches (0 to 305 cm)
250 inches	714 to 1085 inches (1814 to 2756 cm)	0 to 150 inches (0 to 381 cm)
300 inches	858 to 1304 inches (2180 to 3311 cm)	0 to 180 inches (0 to 457 cm)

PowerLite Pro G5550NL/G5950NL, 4:3 image, Long throw zoom lens (part number V12H004L06)

Screen size	Projection distance (A) Wide to Tele	Offset (B)
40 inches	165 to 225 inches (420 to 572 cm)	0 to 24 inches (0 to 61 cm)
50 inches	208 to 283 inches (529 to 719 cm)	0 to 30 inches (0 to 76 cm)
60 inches	251 to 341 inches (639 to 867 cm)	0 to 36 inches (0 to 91 cm)
80 inches	338 to 457 inches (857 to 1162 cm)	0 to 48 inches (0 to 122 cm)

Screen size	Projection distance (A) Wide to Tele	Offset (B)
100 inches	424 to 574 inches (1076 to 1457 cm)	0 to 60 inches (0 to 152 cm)
150 inches	639 to 864 inches (1623 to 2194 cm)	0 to 90 inches (0 to 229 cm)
200 inches	854 to 1154 inches (2170 to 2932 cm)	0 to 120 inches (0 to 305 cm)
250 inches	1070 to 1445 inches (2717 to 3669cm)	0 to 150 inches (0 to 381 cm)
300 inches	1285 to 1735 inches (3264 to 4407 cm)	0 to 180 inches (0 to 457 cm)

PowerLite Pro G5550NL/G5950NL, 4:3 image, Rear projection wide lens (part number V12H004R03)

Screen size	Projection distance (A) Wide to Tele	Offset (B)
30 inches	18 inches (45 cm)	9 inches (23 cm)
40 inches	24 inches (61 cm)	12 inches (30 cm)
50 inches	30 inches (77 cm)	15 inches (38 cm)
60 inches	37 inches (93 cm)	18 inches (46 cm)
80 inches	49 inches (126 cm)	24 inches (61 cm)
100 inches	62 inches (158 cm)	30 inches (76 cm)
150 inches	94 inches (239 cm)	45 inches (114 cm)
200 inches	126 inches (320 cm)	60 inches (152 cm)

Also keep these considerations in mind:

- Place the projector on a sturdy, level surface.
- Make sure there is plenty of space for ventilation around and under the projector.
- Make sure the projector is within 10 feet (3 meters) of a grounded electrical outlet or extension cord.

note

After positioning the projector, you may want to connect a Kensington MicroSaver® anti-theft device to the lock port on the projector. You can purchase this from Epson; see page 15.

Ideally, you should place the projector directly in front of the center of the screen, facing it toward the screen squarely. The base of the lens should be about level with the bottom of the screen.

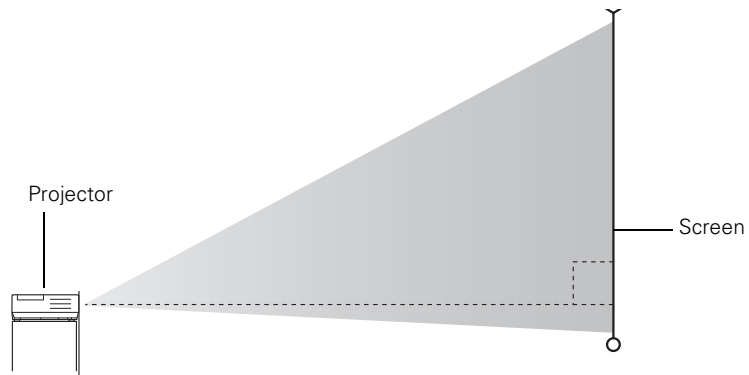

If you place the projector below screen level, you can use the vertical lens shift dial to raise the lens (see page 57). You can also tilt the projector up by extending the front adjustable foot. Tilting the projector causes the image to become “keystone” shaped, but you can correct the distortion (see page 58).

For instructions on installing the projector in a permanent location, such as a theater or conference room, see page 163.

Connecting to a Computer

note

To connect a Macintosh that includes only a Mini DisplayPort or Mini-DVI port for video output, you need to obtain an adapter that allows you to connect to the projector's VGA video port. Contact Apple for compatible adapter options.

You can connect the projector to any computer that has a standard video output (monitor) port, including desktop models, PC and Macintosh computers, and hand-held devices.

If you have the optional wireless mouse receiver, you can use your remote control as a wireless mouse when projecting from a computer (page 70).

Connecting to the DVI-D Port (G5450WUNL/G5750WUNL only)

1. Locate a DVI-D cable.
2. Connect the cable to the DVI-D connector on your computer and the DVI-D connector on the projector.

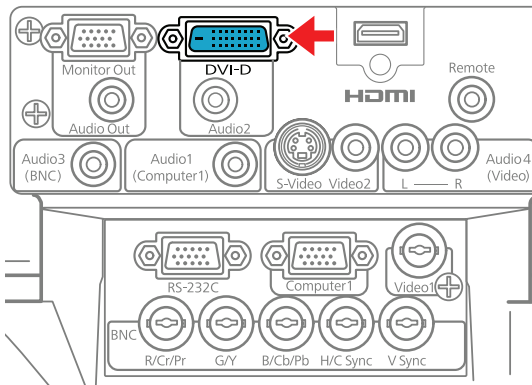

3. If you want to play sound through the projector, see page 46 for instructions on connecting audio cables. With the optional wireless mouse receiver (see page 70), you can use the remote control as a mouse.
4. When you've finished making any connections, see page 51 for instructions on turning on the projector and Chapter 2 for instructions on displaying and adjusting the image.

Connecting a DVI-D Source to the HDMI Port

You can connect your DVI-D source to the projector using a DVI/HDMI conversion cable.

1. Locate a DVI/HDMI conversion cable.
2. Connect the cable to the DVI-D connector on your computer and the HDMI connector on the projector.

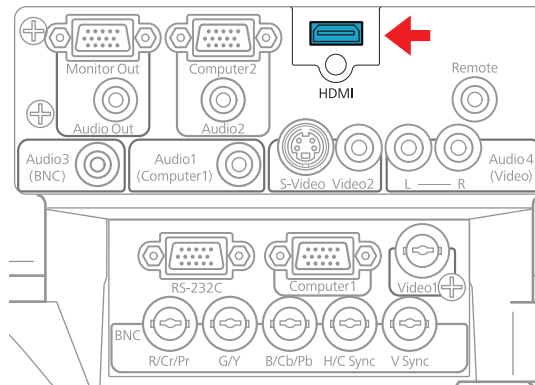

3. With the PowerLite Pro G5550NL/G5650WNL/G5950NL, if you want to play sound through the projector, see page 46 for instructions on connecting audio cables. With the optional wireless mouse receiver (see page 70), you can use the remote control as a mouse.
4. When you've finished making any connections, see page 51 for instructions on turning on the projector and Chapter 2 for instructions on displaying and adjusting the image.

note

With the PowerLite Pro G5450WUNL/G5750WUNL, you must connect your DVI-D source to the DVI-D port in order to play sound.

Connecting to the HDMI Port

1. Locate an HDMI cable.
2. Connect the cable to the HDMI connector on your computer and the HDMI connector on the projector.

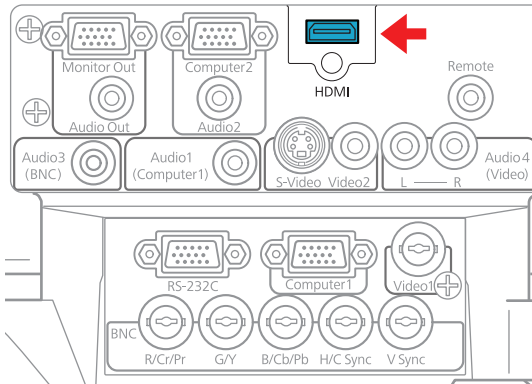

3. See page 51 for instructions on turning on the projector and Chapter 2 for instructions on displaying and adjusting the image. With the optional wireless mouse receiver (see page 70), you can use the remote control as a mouse.

Connecting to the Computer Port

You can connect to the projector using the VGA computer cable that came with it (the monitor port on your computer must be a mini D-sub 15-pin port).

1. If you're using the VGA computer cable, connect one end to the projector's **Computer1** port, and the other end to your computer's monitor port. With the PowerLite Pro G5550NL/G5650WNL/G5950NL, you can also connect to the **Computer2** port.

caution

Don't try to force a connector to fit a port with a different shape or number of pins. You may damage the port or connector.

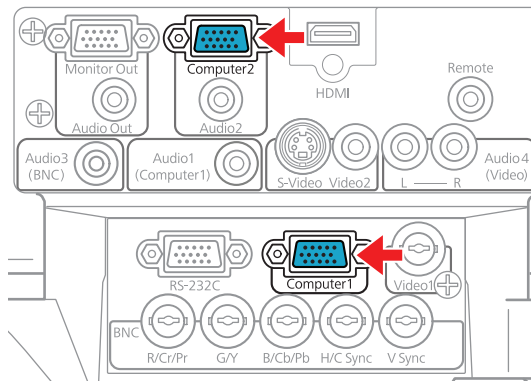

2. You may need to change the **Input Signal** setting in the projector's **Signal** menu to **RGB** (see page 118).
3. If you want to play sound through the projector, see page 46 for instructions on connecting audio cables. With the optional wireless mouse receiver (see page 70), you can use the remote control as a mouse.
4. When you've finished making any connections, see page 51 for instructions on turning on the projector and Chapter 2 for instructions on displaying and adjusting the image.

Connecting to the BNC Connectors

1. Obtain a commercially available standard BNC to VGA video cable.
2. Plug the BNC connectors into the projector's B/Cb/Pb, G/Y, and R/Cr/Pr connectors as shown below. Depending on your computer's video card, you may have to connect to the projector's V Sync and H/C Sync connectors too. (See your computer documentation for more information.)

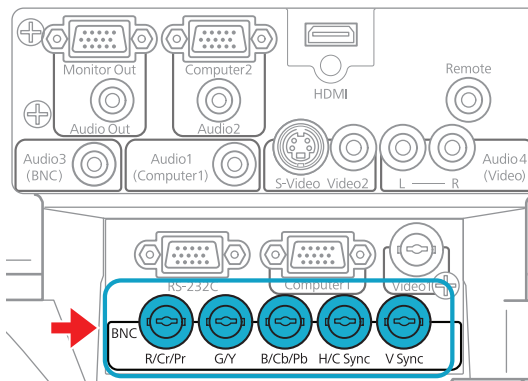

3. Plug the VGA connector on the other end of the cable into your computer's monitor port.
4. You may need to change the **Input Signal** setting in the projector's Signal menu to **RGB** (see page 118).
5. If you want to play sound through the projector, see page 46 for instructions on connecting audio cables. With the optional wireless mouse receiver (see page 70), you can use the remote control as a mouse.
6. When you've finished making any connections, see page 51 for instructions on turning on the projector and Chapter 2 for instructions on displaying and adjusting the image.

Connecting to Video Equipment

You can connect several video sources to the projector at the same time. Before starting, look at your video equipment to determine its available video output connections:

- If your video player has an HDMI connector, see “Connecting an HDMI Video Source” on page 37.

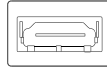

HDMI connector

- If your video player has a DVI-D video port, see “Connecting a DVI-D Video Source to the DVI-D Port (G5450WUNL/G5750WUNL only)” on page 38 or “Connecting a DVI-D Video Source to the HDMI Port” on page 39.
- If your video player has a component video port (three connectors labeled either Y/Cb/Cr or Y/Pb/Pr), see “Connecting a Component Video Source” on page 42.
- If your video player has a yellow RCA video output connector, or if you’re using a coax video cable, see “Connecting a Composite Video Source” on page 40.



BNC connector
(component or
composite video)

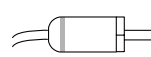

RCA connector
(composite video)

- If your video player has an S-Video connector, see “Connecting an S-Video Source” on page 41.



S-Video
connector

- If your video player has an RGB video port (either a single connector for a VGA monitor cable or three connectors labeled R/G/B), see “Connecting an RGB Video Source” on page 43.

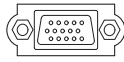

VGA connector
(RGB video)

After connecting video cables, you may also want to connect an audio cable to play sound through the projector; see page 46. If you connect using an HDMI cable, the video and sound are both transferred and you won't need to connect any additional cables for audio.

Connecting an HDMI Video Source

For best image quality, connect your video equipment to the HDMI (High-Definition Multimedia Interface) port, if possible.

1. Locate an HDMI cable.
2. Connect the cable to the HDMI connector on your player and the HDMI connector on the projector.

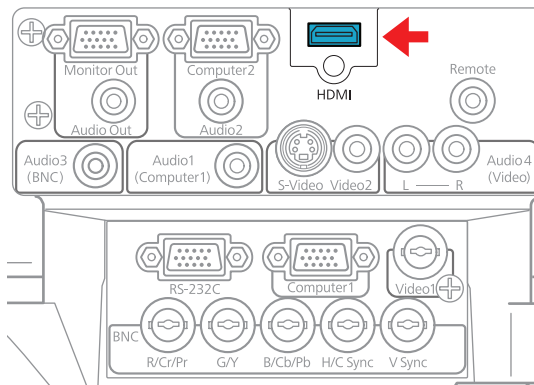

3. See page 51 for instructions on turning on the projector and Chapter 2 for instructions on displaying and adjusting the image.

Connecting a DVI-D Video Source to the DVI-D Port (G5450WUNL/G5750WUNL only)

1. Locate a DVI-D cable.
2. Connect the cable to the DVI-D connector on your player and the DVI-D connector on the projector.

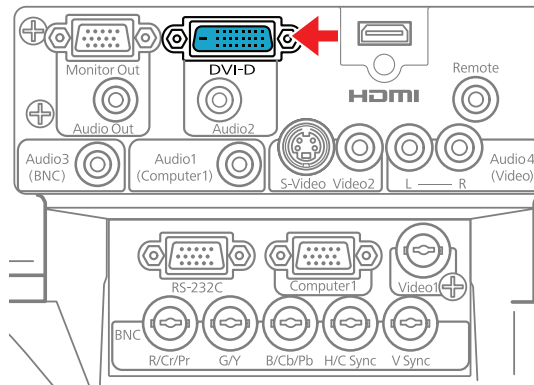

3. If you want to play sound through the projector, see page 46 for instructions on connecting audio cables.
4. When you've finished making any connections, see page 51 for instructions on turning on the projector and Chapter 2 for instructions on displaying and adjusting the image.

Connecting a DVI-D Video Source to the HDMI Port

You can connect your DVI-D source to the projector using a DVI/HDMI conversion cable.

1. Locate a DVI/HDMI conversion cable.
2. Connect the cable to the DVI-D connector on your player and the HDMI connector on the projector.

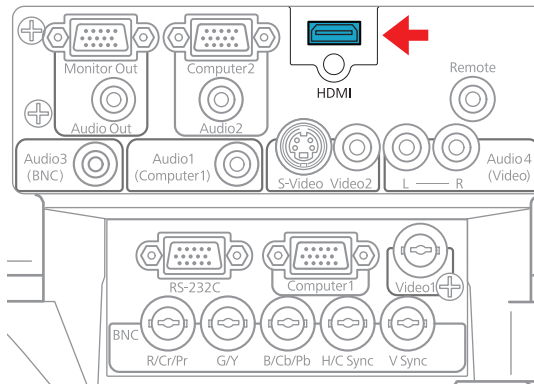

3. With the PowerLite Pro G5550NL/G5650WNL/G5950NL, if you want to play sound through the projector, see page 46 for instructions on connecting audio cables.
4. When you've finished making any connections, see page 51 for instructions on turning on the projector and Chapter 2 for instructions on displaying and adjusting the image.

note

With the PowerLite Pro G5450WUNL/G5750WUNL, you must connect your DVI-D source to the DVI-D port in order to play sound.

Connecting a Composite Video Source

note

If the video cable was not provided with your video device, you can purchase one from an electronics dealer.

1. If your video cable has an RCA connector, connect it to the yellow video output connector on your player and the yellow Video2 connector on the projector (as shown below). Or if you're using a coax video cable, connect it to the Video1 connector on the projector.

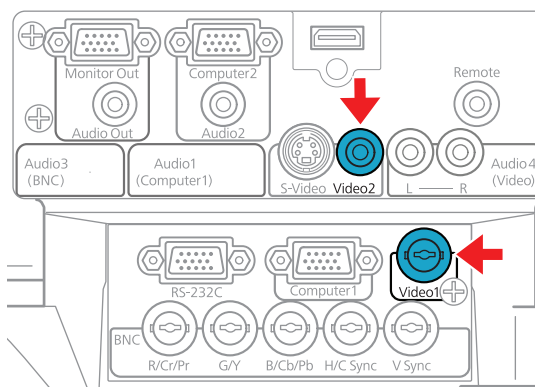

2. If you want to play sound through the projector, see page 46 for instructions on connecting audio cables.
3. When you've finished making any connections, see page 51 for instructions on turning on the projector and Chapter 2 for instructions on displaying and adjusting the image.

Connecting an S-Video Source

1. Connect the S-Video cable to the S-Video connector on your player and the S-Video connector on the projector.

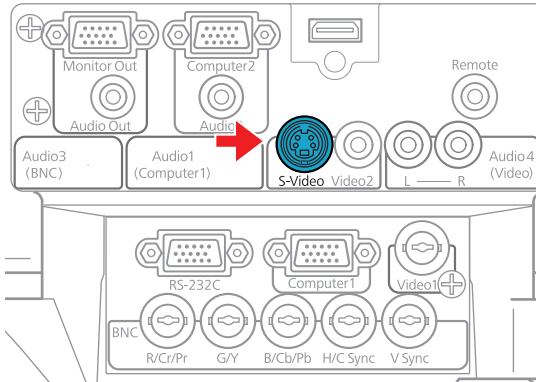

2. If you want to play sound through the projector, see page 46 for instructions on connecting audio cables.
3. When you've finished making any connections, see page 51 for instructions on turning on the projector and Chapter 2 for instructions on displaying and adjusting the image.

note

If the component video cable was not provided with your video device, you can purchase one from an electronics dealer.

note

Be sure your video player is not an RGB video source. If you select the wrong source, image quality may suffer. Check your video player's documentation.

*Also, make sure the Input Signal setting in the Signal menu is set to **Auto** or **Component** (see page 118).*

note

If you have a component-to-VGA video cable, you can use it to connect a component video source. Connect the VGA connector to the projector's Computer1 or Computer2 (G5550NL/G5650WNL/G5950NL only) port, then connect the other end of the cable to your player.

Connecting a Component Video Source

1. Look at the connectors at one end of your component video cable. If they are bayonet (BNC) connectors, go on to step 2. If they are RCA connectors, you'll need to attach commercially available BNC adapters to plug the cable into your projector, then continue with step 2.
2. Connect the cable to your player and the BNC connectors on the projector. Match the Y/Cb/Cr (or Y/Pb/Pr) connectors on your player to the corresponding connectors on the projector.

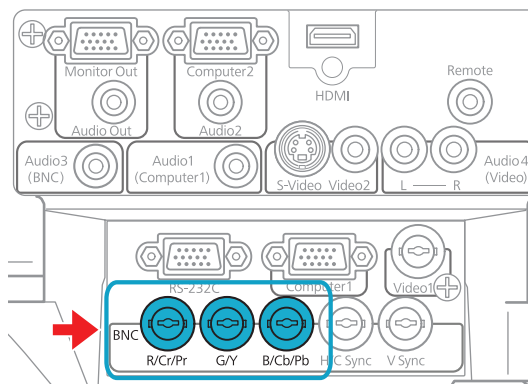

3. You may need to change the Input Signal setting in the projector's Signal menu to **Component** (see page 118).
4. If you want to play sound through the projector, see page 46 for instructions on connecting audio cables.
5. When you've finished making any connections, see page 51 for instructions on turning on the projector and Chapter 2 for instructions on displaying and adjusting the image.

Connecting an RGB Video Source

Connecting Using a VGA Computer Cable

1. Locate the VGA computer cable provided with the projector.
2. Connect the cable to the video port on your player and the **Computer1** port on the projector. With the PowerLite Pro G5550NL/G5650WNL/G5950NL, you can also connect to the **Computer2** port.

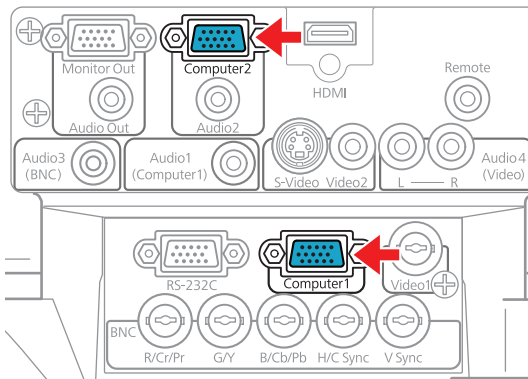

3. You may need to change the **Input Signal** setting in the projector's **Signal** menu to **RGB** (see page 118).
4. If you want to play sound through the projector, see page 46 for instructions on connecting audio cables.
5. When you've finished making any connections, see page 51 for instructions on turning on the projector and Chapter 2 for instructions on displaying and adjusting the image.

note

Be sure your video player is not a component video source. If you select the wrong source, image quality may suffer. Check your video player's documentation.

Connecting Using a BNC Cable

1. Locate a BNC video cable (one may be included with your video equipment).
2. Connect the cable between your player and the corresponding R/G/B connectors on the projector.

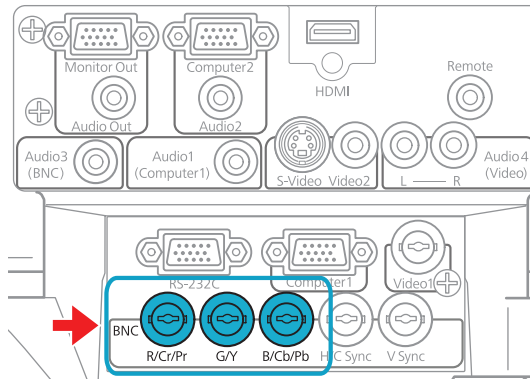

3. You may need to change the **Input Signal** setting in the projector's **Signal** menu to **RGB** (see page 118).
4. If you want to play sound through the projector, see page 46 for instructions on connecting audio cables.
5. When you've finished making any connections, see page 51 for instructions on turning on the projector and Chapter 2 for instructions on displaying and adjusting the image.

Connecting an External Monitor

If you want to monitor your computer presentation close-up (on a monitor placed beside the projector) as well as on the screen, you can connect an external monitor. You can use it to check on your presentation even if you've pressed the **A/V Mute** button or switched to a different picture source.

First make sure your computer's VGA cable is connected to the projector's **Computer1**, **Computer2** (G5550NL/G5650WNL/G5950NL only), or **BNC** ports (see page 34). Then connect your monitor to the projector's **Monitor Out** port, as shown:

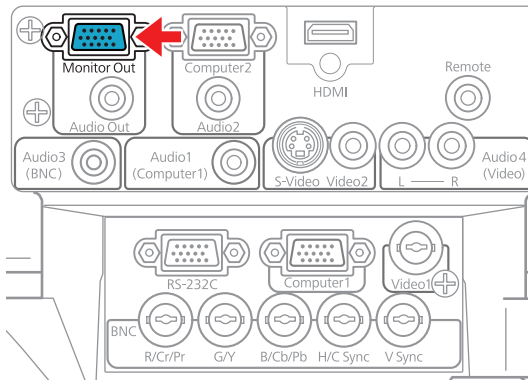

note

The monitor cannot display component video, nor signals connected via the Video1, Video2, S-Video, or HDMI ports.

Some LCD monitors may not be able to display the image correctly. If you have trouble displaying the image, connect a multiscan monitor. If you're projecting computer images, make sure the computer's refresh rate is set to 65 Hz or greater.

The projector must be turned on in order for the Monitor Out port to send a signal to the monitor.

Playing Sound Through the Projector

You can play sound through the projector's speaker system or attach an external speaker system.

To play sound through the projector, follow these steps:

1. Locate the appropriate cable and connect it to the appropriate jack on the projector, as described below.
 - If you have equipment connected to the **Computer1** port, use a stereo mini-jack cable. Connect the cable to the **Audio1** port.

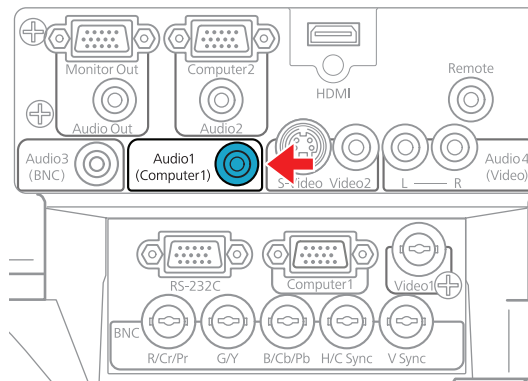

- If you have equipment connected to the **Computer2** port (G5550NL/G5650WNL/G5950NL only), use a stereo mini-jack cable. Connect the cable to the **Audio2** port.

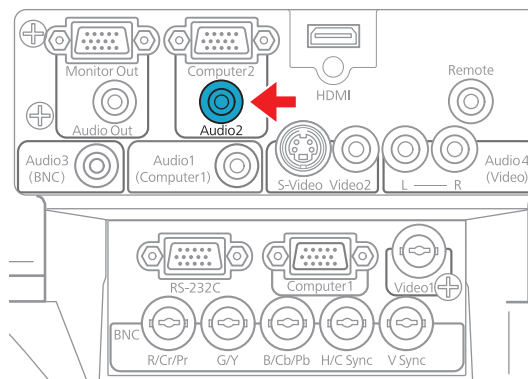

note

If you have equipment connected to the LAN port, in most cases you do not need to connect an additional cable for sound. You can, however, connect an audio cable to the Audio1, Audio2, or Audio3 port (as described in this section) and output the sound by adjusting the Audio Input setting. With the PowerLite G5550NL/G5650WNL/G5950NL, you can also adjust this setting for equipment connected to the HDMI port. See page 119.

If you are using a DVI/HDMI conversion cable to connect your DVI-D source through the HDMI port on the PowerLite G5550NL/G5650WNL/G5950NL, you will need to connect an additional audio cable and adjust the Audio Input setting as described above.

- If you have equipment connected to the DVI-D port (G5450WUNL/G5750WUNL only), use a stereo mini-jack cable. Connect the cable to the Audio2 port.

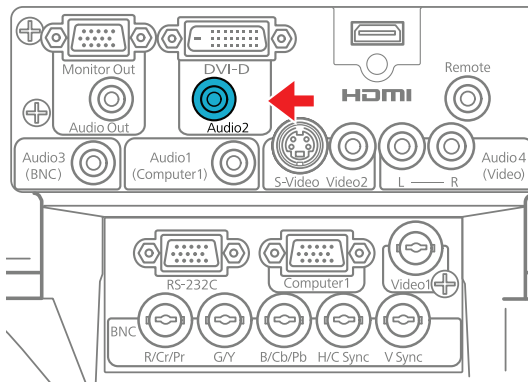

- If you have equipment connected to the BNC ports, use a stereo mini-jack cable. Connect the cable to the Audio3 port.

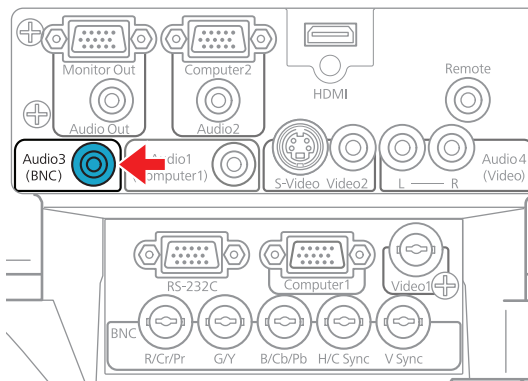

- If you have equipment connected to the Video1, Video2, or S-Video ports, connect an RCA audio cable to the Audio4 ports.

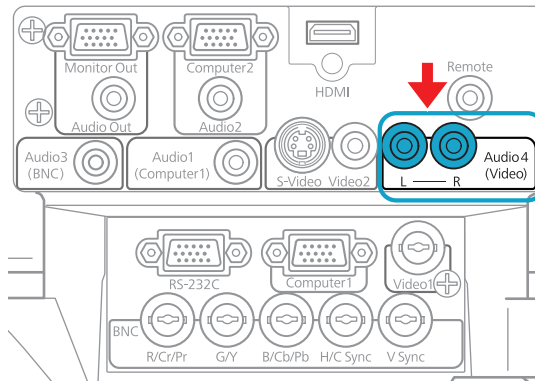

2. Connect the other end of the cable to the audio output connector(s) on your computer or video equipment.

Connecting External Speakers

You can output sound to external speakers with built-in amplifiers. When you play sound through external speakers, the projector's built-in speaker system is disabled. You can use the remote control or the projector's menu system to adjust the volume.

1. Locate the appropriate cable to connect your speakers.

Depending on your speakers, you may be able to use a commercially available audio cable with a stereo mini-jack connector on one end and pin jacks on the other end. For some speakers, you may have to purchase a special cable or use an adapter.

2. Connect the stereo mini-jack end of the audio cable to the **Audio Out** port on the projector.

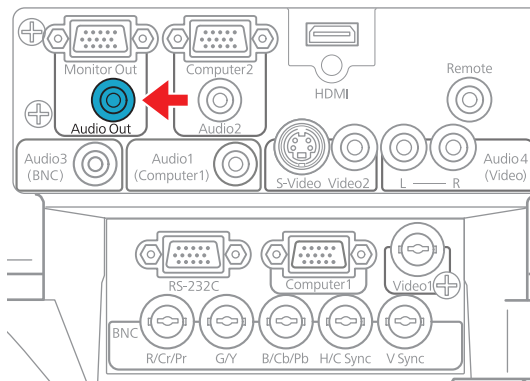

3. Connect the other end of the cable to your speakers.

Connecting to a Digital Camera or Other USB Device

note

Use a cable less than 10 feet (3 meters) long and connect the camera or other device directly to the projector.

Your projector may not function correctly if you use a longer cable or connect your camera to a USB hub.

If you connect a USB hard drive, make sure you use the AC adapter to power the hard drive.

The slideshow function on some devices may not work with the USB connection.

You can connect your digital camera, USB flash memory drive, USB hard drive, or multimedia storage viewer, such as the Epson P-7000 to the projector. Use the USB cable specified for your device, if necessary. Then you can use the projector's PC Free feature. See the *PC Free Operation Guide* for more information.

1. Follow the instructions beginning on page 51 to turn on the projector.
2. Connect the USB drive or the flat end of the USB cable to the  USB port on the projector, as shown.

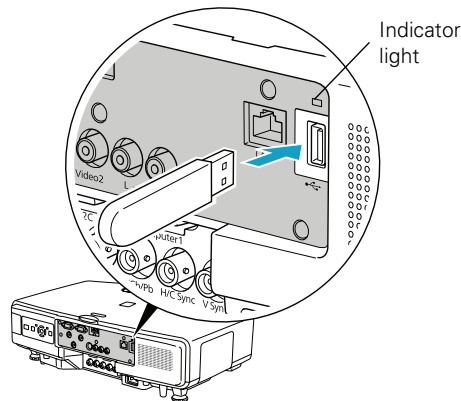

3. Connect the other end of the cable to your camera or other device, if necessary.

The indicator light turns orange when a USB device is connected and green when PC Free is running.

Removing the USB Device or Cable

If you're using PC Free mode to project your images, videos, or presentations, stop the projection before you remove the USB device or cable from the projector.

1. If you're projecting a still image, press the **Esc** button on the remote or the projector's control panel.
2. If you're projecting a slideshow of your images, a movie, or a presentation, press the **Esc** button on the remote or the projector's control panel. Then select **Exit** in the window that appears and press the **Enter**.
3. Turn off your digital camera or other device.
4. Disconnect the USB device or cable.

Turning the Projector On and Off

Turn on any connected computer or video equipment before starting the projector so it can automatically detect and display the image source. If you turn on the projector first, or have multiple pieces of connected equipment, you may have to select the image source manually (see page 56).

Follow these steps to turn on the projector:

1. Remove the lens cover.

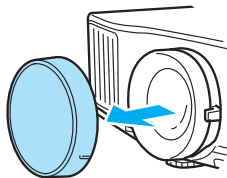

note

You can set the projector to automatically turn off the lamp and enter “sleep mode” when it has not received any signals for 1 to 30 minutes (see page 126 to enable, disable, or adjust this setting). This conserves electricity, cools the projector, and extends the life of the lamp. If you want to start projecting again, press the  power button. If you are done using the projector, unplug the power cord.

2. Plug one end of the power cord into the projector, and the other end into an electrical outlet.

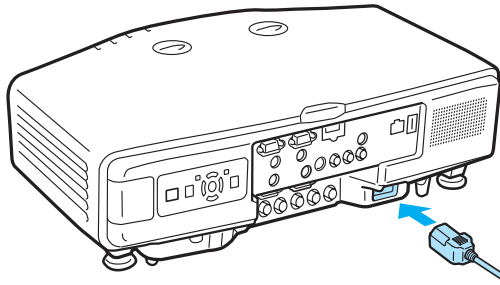

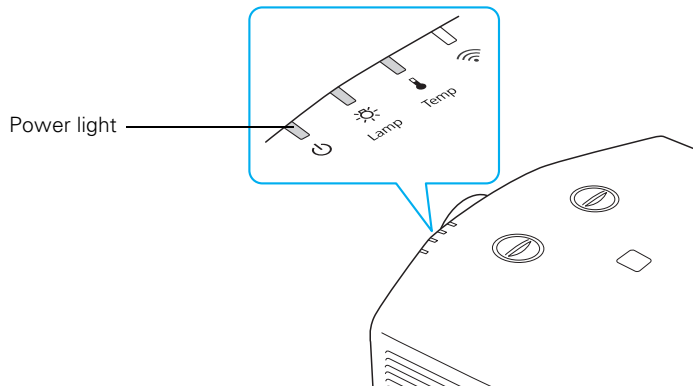

The  power light turns orange.

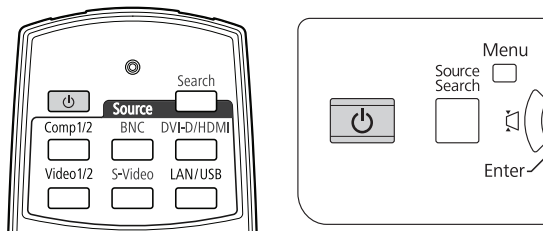

3. Press the  power button on the remote control or on the back of the projector.



The projector beeps once and the  power light flashes green as the projector warms up, then an image begins to appear. When the  power light stops flashing and remains green, the projector is ready for use.

4. If you are prompted to enter a password, see page 122.

Using the Direct Power On Function

The Direct Power On function enables faster setup. The projector starts up automatically when you plug it in or turn it on with a wall switch. You don't have to press the  power button.

Follow these steps to enable Direct Power On:

1. Press the **Menu** button on the remote control or projector, then select the **Extended** menu and press **Enter**.
2. Choose **Operation** and press **Enter**.
3. Choose **Direct Power On** and press **Enter**.

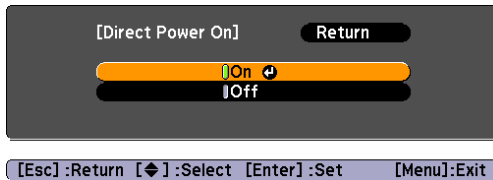

4. Highlight **On** and press **Enter**.
5. Press **Menu** to exit. The setting will take effect the next time you plug in the projector.

warning

Never look into the lens when the lamp is on. This can damage your eyes, and is especially dangerous for children and pets.

note

If a power outage occurs when Direct Power On is enabled and the projector is plugged in, the projector will restart when the power is restored.

note

Turn off this product when not in use to prolong the life of the projector.

Shutting Down the Projector

This projector incorporates Instant Off technology. To turn it off, you can press its  power button as described below, unplug it, or turn off a power switch that supplies power to the projector. You don't have to wait for the projector to cool down first.



1. To turn off the projector, press the  power button on the remote control or projector.

You see a confirmation message.
(If you don't want to turn it off, press any other button.)

Power Off?

Yes: Press  button
No : Press any other button

2. Press the  power button again. The projection lamp turns off and the projector beeps twice, and you can unplug the power cord.

If you want to turn the projector on again, make sure the orange  power light is not flashing, then press the  power button.

2

Displaying and Adjusting the Image

Follow the guidelines in this chapter for:

- Displaying an image
- Adjusting the image
- Projecting two images simultaneously

Displaying an Image

You may need to select the image source if you have multiple video sources connected to the projector (such as a computer or DVD player). Selecting the image source lets you switch between images input from different pieces of connected equipment.

If you don't see the image you want, press the **Search** button or one of the **Source** buttons on the remote control, or the **Source Search** button on the projector until you see the image you want to project.

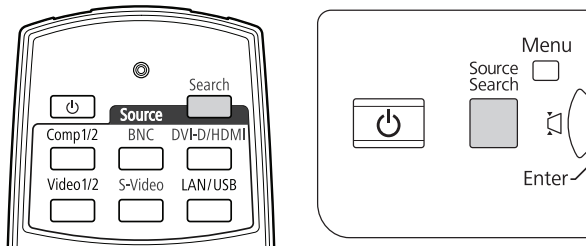

You can also use the **Source** buttons on the remote control to switch between devices connected to the ports identified on each button.

Adjusting the Image

note

The projector can display a test pattern to help you adjust some image settings. See page 119.

Once you see your image, you need to make certain adjustments:

- If the image is too high or too low, reposition it as described on page 57.
- To focus or zoom your image, see page 58.
- If the image isn't square, see page 58.
- To quickly adjust the color, brightness, or contrast, see page 60.
- To change the image aspect ratio, see page 61.
- If you need to fine-tune the image and/or sound, see Chapter 5.

Adjusting the Position of the Image

You can use the vertical lens shift dial on the top of the projector to move your image up or down, or you can use the horizontal lens shift dial to move your image left or right.

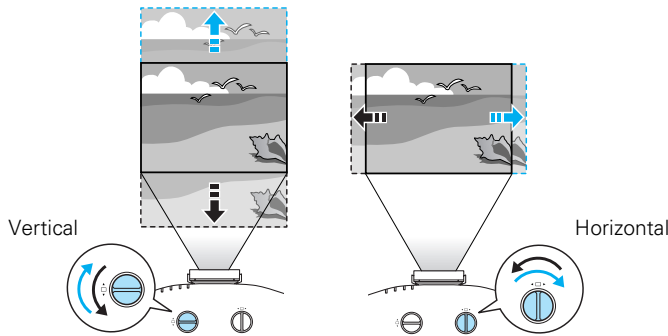

Additionally, if the projector is on a table, you can use the projector's adjustable feet to adjust the image:

1. Stand behind the projector. Press the foot release lever up and lift the front of the projector.

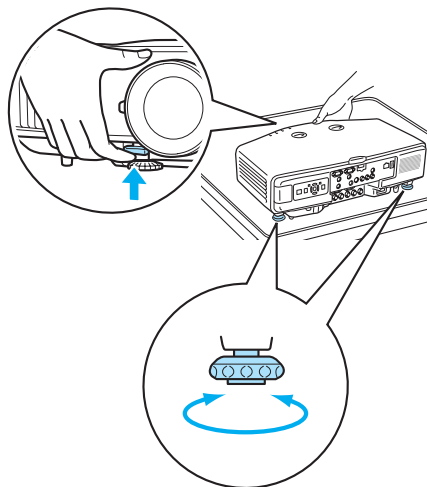

2. Once the image is positioned where you want it, release the lever to lock the foot in position.

note

Raising the projector with the front adjustable foot causes the image shape to distort or “keystone,” but you can correct the shape as described on page 58.

3. If necessary, you can fine-tune the height or level the image by turning any of the projector's adjustable feet.

Focusing and Zooming the Image

Turn the focus ring on the projector to sharpen the image.

Turn the zoom ring (using the knobs on the ring) to reduce or enlarge the image.

note

If you have installed the Rear Projection Wide Lens (part number V12H004R03), you cannot use the zoom ring to reduce or enlarge the image, but you can still use the E-Zoom buttons on the remote control.

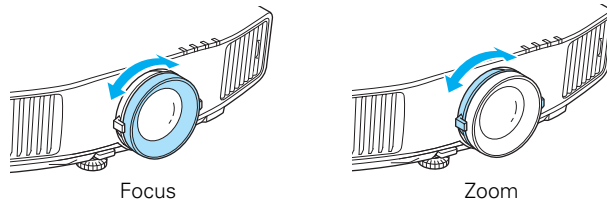

If the image still isn't large enough, you may need to move the projector farther away from the screen. You can also use the E-ZOOM buttons on the remote control to zoom in on a portion of the image. See page 68 for instructions.

Adjusting the Image Shape

You can maintain a square or rectangular image by placing the projector directly in front of the screen and keeping it level. This also produces the best picture quality. If the projector is tilted up or placed at an angle, you'll need to correct the image shape by using one of the functions described below.



Using Quick Corner

Use Quick Corner to adjust the shape and size of the image when it's uneven on all sides. Follow these steps to select Quick Corner:

1. Press the **Menu** button on the remote control or the projector.
2. Select the **Settings** menu and press **Enter**.
3. From the Settings menu, select **Keystone** and press **Enter**.
4. Select **Quick Corner** and press **Enter** twice.

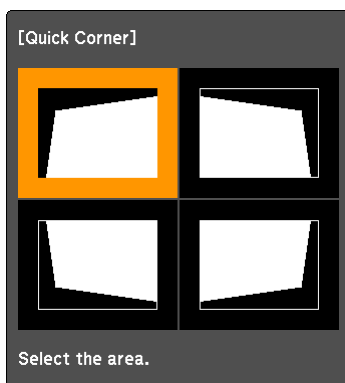
You see this screen:



5. Use the  pointer button on the remote control (or the arrow buttons on the projector) to select the corner you want to adjust, and press **Enter**.
6. Use the  pointer button on the remote control (or the arrow buttons on the projector) to adjust the shape, then press **Esc** when you are finished.
7. Repeat steps 5 and 6 as needed to adjust the other corners.
8. When you're done, press **Esc** to exit.

Using Keystone Correction

You can manually adjust the shape of the image to compensate for vertical and horizontal keystone distortion.

Before performing horizontal or vertical keystone, use the lens shift function to horizontally center the lens and vertically move the lens to the top or bottom (see page 57); otherwise, the distortion will not be corrected accurately. Also, the distortion may not be corrected accurately for some zoom settings.

1. Press the **Menu** button on the remote control or projector.
2. Select the **Settings** menu and press **Enter**.
3. From the Settings menu, select **Keystone** and press **Enter**.
4. Select **H/V-Keystone** and press **Enter**.

note

To undo your Quick Corner adjustments, press and hold the **Esc** button for about 2 seconds, select **Reset Quick Corner** from the screen that appears, then press **Enter**.

note

Epson recommends using Quick Corner to accurately adjust keystone distortion. See page 58.

note

You can also use the projector's arrow buttons to perform keystone correction as long as the projector's Keystone setting is set to H/V-Keystone.

5. Select **H-Keystone** (for horizontal adjustment) or **V-Keystone** (for vertical adjustment) and use the  pointer button on the remote control to adjust the shape of the image.

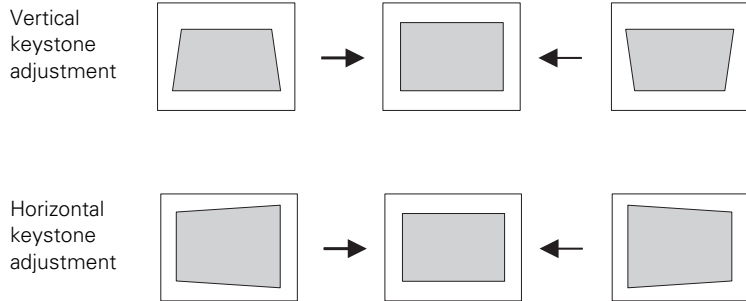

If the image becomes smaller, use the zoom ring to enlarge the image so it fits the screen. If the image contains faint lines or a gridlike pattern, decrease the sharpness setting (see page 115).

6. When you're done, press **Menu** to exit.

Selecting the Color Mode

The Color Mode adjusts the brightness, contrast, and color for various common viewing environments. Use this setting to quickly obtain a good picture.

Press the **Color Mode** button on the remote control, and then select from one of these options:

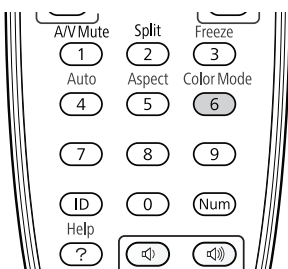

- **Dynamic:** Brightest mode; for video games or TV in a bright room.
- **Presentation:** For making color presentations in a bright room.
- **Theatre:** For watching movies in a darkened room; gives images a natural tone.
- **Photo:** For vivid, high-contrast still images in a bright room (RGB signals or signals input through the  USB or LAN ports only).
- **Sports:** For vivid TV images projected in a bright room (component video, S-Video, or composite video only).

- **sRGB:** Matches the color palette of standard sRGB computer displays.
- **DICOM SIM:** Ideal for projecting X-ray photographs and other medical images.
- **Customized:** For manual color adjustment (see page 115).

You can also change the Color Mode using the projector's Image menu. See page 114 for details.

Resizing Video Images

You can use the **Aspect** button on the remote control to change the aspect (width to height) ratio, depending on the input signal.

- **Auto** (video equipment and HDMI images only): Automatically sets the aspect ratio according to the input signal. Choose this setting to project an HDMI image in the best aspect ratio.
- **Normal** (computer images only): Displays images using the full projection area and maintains the aspect ratio of the image. Choose this setting to automatically resize the image and make the best use of the display area.
- **4:3** (G5550NL/G5950NL only): Displays images using the full projection area at an aspect ratio of 4:3.
- **16:9:** Converts the aspect ratio of the image to 16:9. 4:3 ratio images are elongated horizontally to fit.
- **Full** (G5450WUNL/G5650WNL/G5750WUNL only): Displays images using the full width of the projection area, but does not retain the aspect ratio. 4:3 ratio images are elongated horizontally.
- **Zoom** (G5450WUNL/G5650WNL/G5750WUNL only): Displays images using the full width of the projection area and maintains the aspect ratio of the image. The image may be cut off on the top and bottom depending on its aspect ratio.
- **Native** (HDMI and computer images only if you are using the G5550NL/G5950NL): Displays images as is (aspect ratio and resolution are maintained). Black bands appear if the resolution is less than 1024 × 768 (G5550NL/G5950NL), 1280 × 800

note

The projector is not a medical device and cannot be used for medical diagnosis.

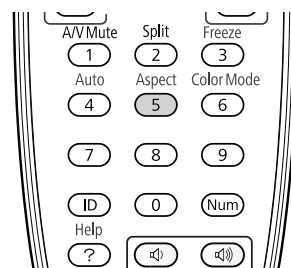

note

To select Full while inputting a 1080i signal, set the Progressive setting to Off. See page 116.

(G5650WNL), or 1920 × 1200 (G5450WUNL/G5750WUNL); images are cut off if the resolution is over 1024 × 768 (G5550NL/G5950NL), 1280 × 800 (G5650WNL), or 1920 × 1200 (G5450WUNL/G5750WUNL).

Press the **Aspect** button repeatedly to cycle through the available options.

You can also change the aspect ratio using the projector's Signal menu. See page 116 for details.

note

In order to use the Split Screen feature, one of your images must be input through the HDMI or DVI-D (G5450WUNL/G5750WUNL only) port. The other image can be input through the Computer1, Computer2 (G5550NL/G5650WNL/G5950NL only), BNC, S-Video, Video1, or Video2 ports.

Images input through the USB or LAN port cannot be projected as part of the split screen.

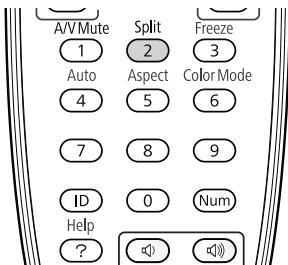

Projecting Two Images Simultaneously

You can use the projector's split screen feature to divide the screen into left and right sections and simultaneously project two images.

Follow these steps to activate the split screen:

1. Press the **Split** button on the remote control. The currently selected input source will move to the left side of the screen.
2. Press the **Menu** button. You see the following screen:

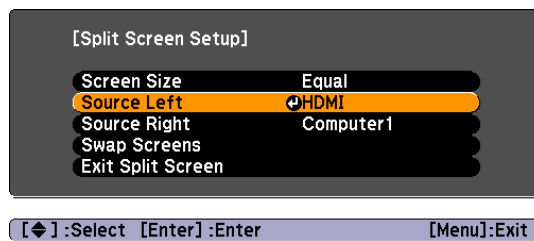

3. To change one of the images, highlight either **Source Left** or **Source Right** (whichever side contains the image you want to change) and press **Enter**. Then highlight the input source you want to change to and press **Enter** again.
4. To switch the images, highlight **Swap Screens** and press **Enter**.
5. To change one of the image sizes, highlight **Screen Size** and press **Enter**. Then highlight a sizing option and press **Enter** again. Press **Menu** to exit.

Depending on the video signals that are input, the images on the left and right may not appear at the same size even if you choose **Equal** as the sizing option.

6. To end the split screen, do one of the following:
 - Press the **Esc** button on the remote control or the projector's control panel.
 - Press the **Split** button on the remote control.
 - Select **Exit Split Screen** from the Split Screen Setup window and press **Enter**.

You cannot do the following while the split screen is active:

- Use the projector's on-screen menus
- Use the E-Zoom feature
- Change the aspect ratio of either image
- Use the **User** button on the remote control
- Use the **Help** button (unless an error or warning is occurring)

Additionally, while you are using the split screen:

- The audio from the source on the left side of the screen will be output.
- The **Color Mode**, **Abs. Color Temp**, and **Color Adjustment** settings for the image on the left are applied to the image on the right (all of the remaining settings in the projector's **Image** menu are set to default for the image on the right side).
- You cannot use the **Thin Line Enhancement** or **Thick Line Enhancement** settings or the **Progressive**, **Noise Reduction**, or **2-2 Pull-down** features.
- The **Overscan** setting is set to its default value, if applicable.
- The screen will be blue for any side which is not receiving a signal, and the screen will turn black when the **A/V Mute** button is pressed.

- The image on the left side of the screen can be output to an external monitor as long as it meets the requirements (see page 45).

You can also activate the split screen using the projector's **Signal** menu. See page 119 for details.

3 *Presenting With the Remote Control*

The projector includes a number of tools to enhance your presentation. All of them can be accessed using the remote control, which lets you operate the projector from anywhere in the room—up to 49 feet (15 meters) away.

You can use the remote control to adjust the picture and sound (page 66), as a pointer to highlight your presentation (page 69), or to control two or more projectors at the same time (page 71). If you have the optional wireless mouse receiver, you can also use your remote control as a wireless mouse when projecting from a computer (page 70).

This chapter covers:

- Using the remote control
- Controlling the picture and sound
- Highlighting your presentation
- Operating your computer with the remote control
- Operating two or more projectors with the remote control

note

If a button is pressed longer than 30 seconds, the remote control stops operating to conserve battery power. When you release the button, normal operation resumes.

note

Using the remote under bright fluorescent lamps or in direct sunlight may affect projector response.

Using the Remote Control

Make sure batteries are installed as described on page 142. Follow these tips for using the remote control:

- Point the remote control at the front of the projector or at the screen.
- Stand within 49 feet (15 meters) of the projector.

Controlling the Picture and Sound

You can use the remote control to preview and select your picture sources, temporarily turn off the picture and sound, freeze the action, zoom in on the picture, and adjust the volume.

Switching Between Picture Sources

If your projector is connected to more than one computer and/or video source, you can switch between the different sources:

- The easiest way to select your source is to press the **Search** button on the remote control (or the **Source Search** button on the projector) repeatedly until you see the image you want on the screen.

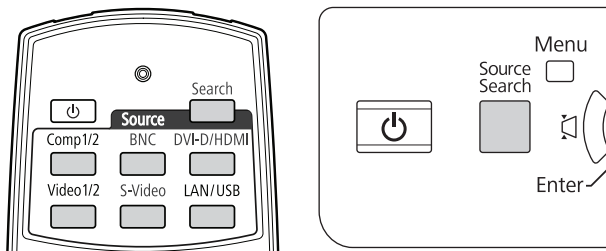

- On the remote control, you can press one of the **Source** buttons to select the connected device you need.

After you select a source, the screen goes dark for a moment before the image appears.

Turning Off the Picture and Sound

You can temporarily turn off the image and sound by pressing the A/V Mute button on the remote control. This turns the image black and stops the sound. To turn the image and sound back on, press the button again.

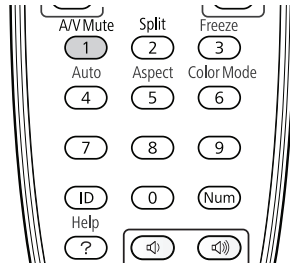

You can have the screen turn blue (using the Display setting as described on page 126) or display an image such as a company logo when you press the A/V Mute button. (See page 123 for more information on displaying an image.)

Stopping Action

Press the Freeze button on the remote control to stop the action in your video or computer image. The image freezes but the sound continues.

To restart the action, press the Freeze button again.

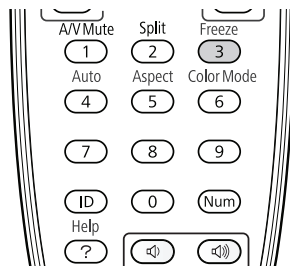



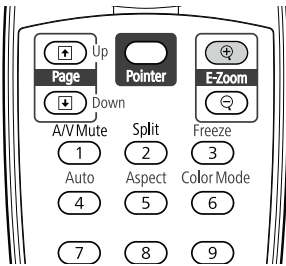

note

This function pauses the image, not the sound. Because the source continues to transmit signals, when you resume the action, it won't be at the point you stopped it.



Zooming Part of Your Image



You can zoom in on a portion of the image using the E-Zoom buttons on the remote control.

1. Press the E-Zoom  button on the remote control.
You see a crosshair indicating the center of the zoom-in area.
2. Use the  pointer button to position the crosshair.
3. Continue pressing the E-Zoom  button to enlarge the selected area up to 4 times.
4. While the image is enlarged, you can:
 - Use the  pointer button to move around the screen.
 - Press the E-Zoom  button to zoom out.
5. When done, press the Esc button to return the image to its original size.

note

You cannot use the Progressive or Noise Reduction features (see page 116) while you are using E-Zoom.

Controlling the Volume

To change the volume, press the  or  button on the remote control.

note

To temporarily shut off the sound and picture, press the A/V Mute button.

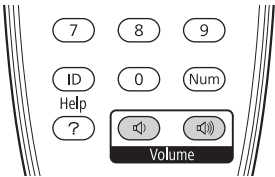

You can also adjust the volume using the projector's menu system. See page 120.

Highlighting Your Presentation



You can display a pointer to call out important information on the screen, and you can choose from three shapes for the pointer.

Using the Pointer Tool

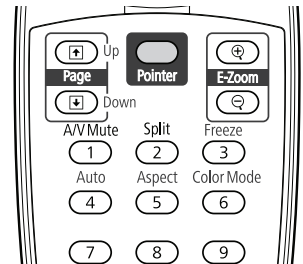
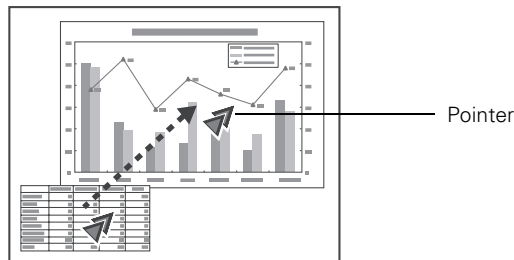
1. To activate the pointer tool, press the **Pointer** button on the remote control. A pointer appears on the screen.



If you prefer to use a different style of pointer, see the instructions in the next section.

2. Use the  pointer button on the remote control to position the pointer on the screen.
3. When you're done using the pointer, press the  pointer button to clear the screen.

Choosing a Different Pointer Shape

Follow these steps to select a different pointer shape:

1. Press the **Menu** button on the remote control, highlight the **Settings** menu, and press **Enter**. Then highlight **Pointer Shape** and press **Enter**. You can select one of the pointer shapes shown at the right.
2. Select the shape you want and press **Enter**.
3. Press **Menu** to exit.





Operating Your Computer With the Remote Control



With the optional wireless mouse receiver (see page 15), you can use the remote control in place of your computer's mouse. This gives you more flexibility when delivering slideshow-style presentations, since you won't have to stand next to the computer to change slides.

note

You can also use the **Up** and **Down** buttons to move through a presentation that is being projected over a network or from a device connected to the projector's  **USB port**.

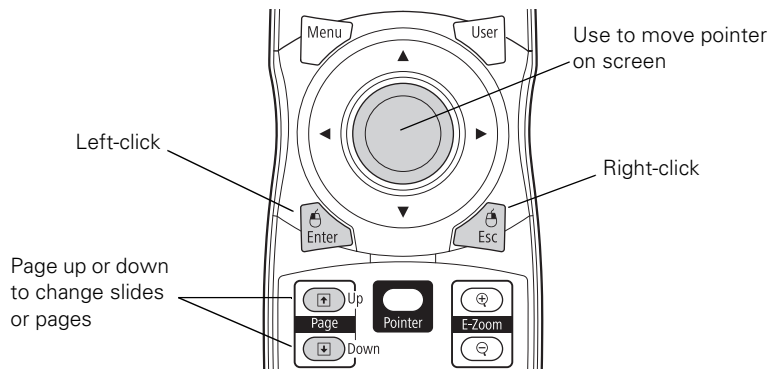
- Use the  **Up** and  **Down** buttons to move through slides or pages in a presentation.



- Use the  pointer button to move the pointer on the screen.
- Press the **Enter** button once to left-click, or twice to double-click. Press the **Esc** button to right-click.
- To drag-and-drop, hold down the **Enter** button. Then use the  pointer button to drag the object. When it's where you want it, release the **Enter** button.

Operating Two or More Projectors With the Remote Control

If you're using more than one projector, you can control all the projectors—or just selected ones—by using the projector ID system. To operate a projector, set the remote control's ID to match that of the projector. Or you can control all the projectors at once by setting the remote control's ID to zero.

Setting the Projector ID

The projector's default ID is set to Off. This lets it respond to commands from any remote control. To change the ID, follow these steps:

1. Press the **Menu** button on the remote control. You see the projector's menu screen.
2. Select **Extended**, press **Enter**, select **Projector ID**, then press **Enter** again.

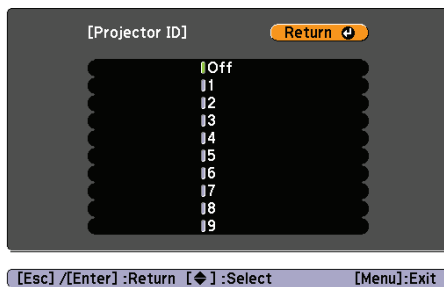

3. Use the  pointer button to highlight the new ID, and press **Enter** to select it.
4. When you're done, press **Menu** to exit.

Checking the Projector ID

You can check the projector's ID by following these steps:

1. Move the remote control ID switch to the **On** position.

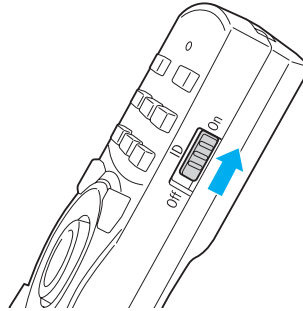

2. Point the remote control at the projector you want to check.
3. While holding the ID button, press the **Help** button. You see a message on the screen like this:

Projector ID: 2

Setting the Remote Control ID

The remote control's default ID is zero. This lets you operate any projector. To set it to operate a specific projector, follow these steps:

1. Move the remote control ID switch to the **On** position.

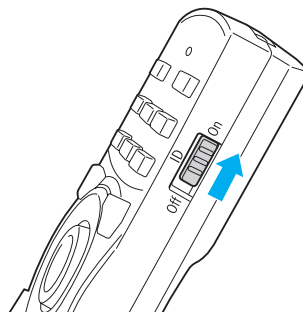

note

*When the remote control ID switch is in the **Off** position, you can control any projector regardless of the projector or remote control ID settings.*

2. Press and hold the ID button on the remote control.

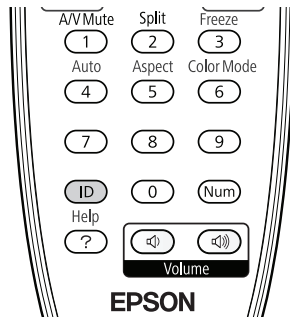

3. While holding the ID button, press a numbered button on the remote control (0 through 9) to select the desired ID. Select zero to control all projectors, or select a number to match the ID of the projector(s) you want to operate.

4

Using the Projector on a Network

You can use Quick Wireless Connection or EasyMP® Network Projection to project images shown on your computer screen—including text, graphics, and video—directly to your audience. See the *EasyMP Network Projection Operation Guide* for information on features and use.

You can use EasyMP Monitor (available for Windows only) to monitor and control your projector through the network. For information on installing and using EasyMP Monitor, see the *EasyMP Monitor Operation Guide*.

You can use EasyMP Multi PC Projection to simultaneously display images from different networked computers. For information on installing and using EasyMP Multi PC Projection, see the *EasyMP Multi PC Projection Operation Guide*.

You'll find instructions in this chapter on:

- Connecting the projector to a wired LAN
- Installing the optional wireless LAN module
- Using Quick Wireless Connection
- Configuring projector and network settings
- Using wireless security options
- Removing the optional wireless LAN module
- Sending e-mail alerts and monitoring the projector
- Using a browser to control the projector

For a wireless connection, make sure you've installed the optional Wireless 802.11g/b/a Module, as described on page 78. Then follow the steps in this chapter to use Quick Wireless Connection (Windows only) or configure your projector and network. See the *EasyMP Network Projection Operation Guide* for instructions on installing the EasyMP Network Projection software. The *EasyMP Network Projection Operation Guide* also contains instructions on using the software to project over the network.

Connecting to a Wired Network

With an Ethernet cable, you can connect the projector to your network and configure it with an IP address.

1. Connect the projector to your network using a commercially available 100BaseTX or 10BaseT network cable. Connect the cable to the LAN port on the projector as shown. To ensure proper data transmission, use a shielded, Category-5 cable or better.

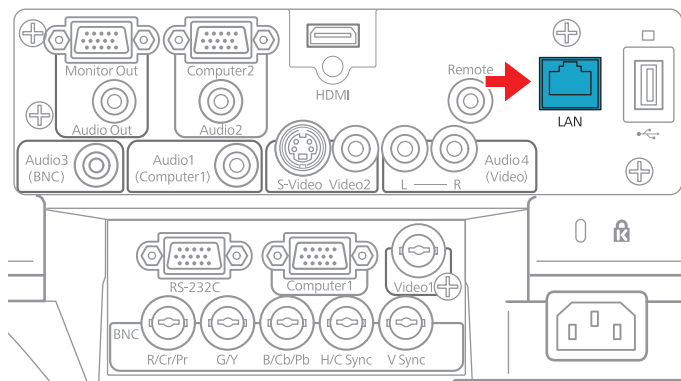

2. Connect the other end to your Ethernet hub or router.
3. Turn on the projector.
4. Press the **Menu** button, select the **Network** menu, then press **Enter**.
5. Choose **Network Configuration** and press **Enter**.

6. Choose **Wired LAN** and press **Enter**. You see the following screen:



7. Do one of the following:
 - If your network assigns addresses automatically, turn on the **DHCP** setting.
 - If your network does not assign addresses automatically, turn off **DHCP** and enter the projector's **IP Address**, **Subnet Mask**, and **Gateway Address**.

To enter numbers, use the  pointer button on the remote control to highlight the number you want to input, then press the **Enter** button.
8. To prevent the IP address from appearing on the standby screen, set the **IP Address Display** setting to **Off**.
9. When you're done making all necessary changes, highlight the **Return** button at the top of the screen, then press **Enter**. Choose **Setup complete** and press **Enter**, then choose **Yes** and press **Enter** to save the changes.
10. Press **Menu** to exit.

Installing the Optional Wireless 802.11g/b/a Module

Make sure you have the optional Wireless 802.11g/b/a Module. Turn off the projector and disconnect the power cord before you install the module.

1. Remove the cover from the wireless module's insertion area.

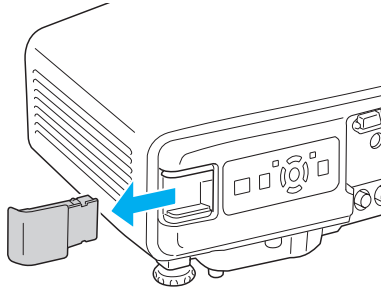

2. Insert the Wireless 802.11g/b/a Module as shown.

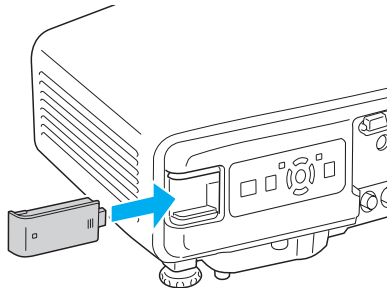

3. Fasten the module using the screw that came with it.

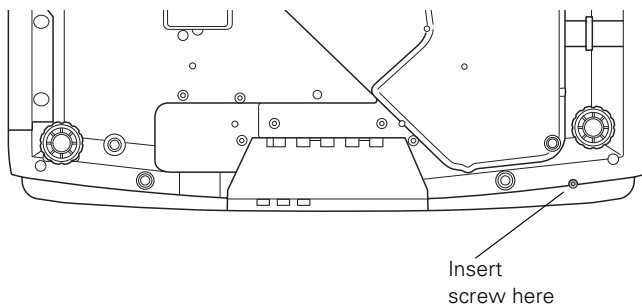

If you have the optional USB key, you can use Quick Wireless connection as described in the next section. Or, you can configure your connection manually as described on page 80.

Using Quick Wireless Connection

Using the optional USB key, you can quickly connect the projector to a Windows computer wirelessly without any configuration.

First, make sure you have installed the optional wireless module as described on page 78 and turned on the projector.

1. Connect the USB key to the projector's  USB port.
2. When you see a projected message that the network information update is complete, remove the USB key.
3. Connect the USB key to a USB port on your computer or notebook.

In Windows 7 or Windows Vista, if you see the AutoPlay window, select **Run LaunchQW.exe**. When you see the User Account Control screen, click **Allow**.

4. Follow the instructions on the screen to install the Quick Wireless Connection driver.

If you see a Windows Firewall message, click **Yes** to disable the firewall.

After a few minutes, your computer image will be displayed through the projector. If not, try restarting your computer.

5. When you're done with your presentation, remove the USB key. You may need to restart your computer to reactivate your wireless interface.

note

Do not attempt to write to the USB key or use it as a flash memory drive.

note

The Quick Wireless Connection utility will disable any other wireless sessions and adapter programs. Make sure you leave the USB key in your computer for your entire Quick Wireless Connection session.

Configuring Basic Settings

You can give your projector a unique name, enable a projector keyword, or create a password for controlling the projector over the Web.

1. Press the **Menu** button, then choose **Network** and press **Enter**.
2. Choose **Network Configuration** and press **Enter**. You see a screen like the following:

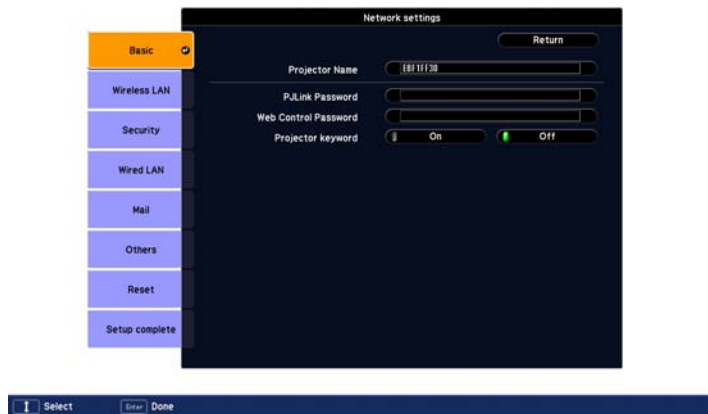

3. Make sure the projector has a unique name, so you can identify it on your network.

If you need to rename it, highlight the **Projector Name** text box then press **Enter**.

4. Use the  pointer button on the remote control to select individual letters, then press **Enter** to input a character. To add a blank space or to navigate backward and forward through the input text, highlight the arrows and press **Enter**. To toggle symbol settings or capital letters, highlight the option and press **Enter**. When you're done, highlight **Finish** and press **Enter**.

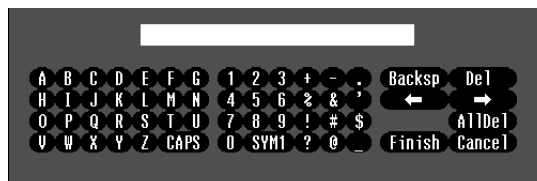

5. If you want to create a password for using PJLink to control the projector, highlight **PJLink Password**, press **Enter**, and enter a password of up to 8 alphanumeric characters. When you're done, highlight **Finish** and press **Enter**.
6. If you want to create a password for remote access to the projector, highlight **Web Control Password**, press **Enter**, and enter a password of up to 8 alphanumeric characters. When you're done, highlight **Finish** and press **Enter**.
7. If you want to set up a security keyword so that only people who are in the same room as the projector can access it, set the **Projector keyword** option to **On**. Then when you want to connect to the projector, it displays a randomized four-digit number or "keyword" on the screen. If you're using EasyMP Network Projection, you can enter the keyword on your computer to connect (see the *EasyMP Network Projection Operation Guide* for details).
8. When you're done making these settings, highlight the **Return** button at the top of the screen, then press **Enter**. Choose **Complete** and press **Enter**, then choose **Yes** and press **Enter** to save your settings.
9. Press **Menu** to exit.

Configuring a Wireless Connection

After you install the optional Wireless 802.11g/b/a Module, you can use the EasyMP Network Projection software to connect to the projector and send images wirelessly in two modes: Ad Hoc mode or Access Point mode.

- **Ad Hoc mode** (computer-to-computer mode) lets you connect just one computer to the projector at a time; it's easy to set up, and the only equipment you need is a computer with a wireless (802.11g, 802.11b, or 802.11a) network card or adapter, or a Macintosh with an AirPort® or AirPort Extreme card. When you connect with this mode, any connection to other wireless networks is broken; you can connect to the projector only.

note

*You can interrupt projection even when a keyword is used. Press the **Esc** button on the remote control and select the **Close** option.*

note

Make sure you've installed the EasyMP Network Projection software as described in the EasyMP Network Projection Operation Guide.

To connect to the projector over a wireless network, your computer must be running Windows 7, Windows Vista, Windows XP, or Windows 2000. Your Mac must be running Mac OS X 10.3 to 10.6.

Access Point mode (infrastructure mode) is required to achieve transfer speeds up to 54MB/sec on an 802.11g network. Ad Hoc mode (computer-to-computer mode) limits network connections to 11MB/sec. This is a standard specification of 802.11g networking.



- **Access Point mode** (infrastructure mode) lets multiple computers access the projector at the same time and easily trade off control over the projector. To use Access Point mode, you need a wireless (802.11g, 802.11b, or 802.11a) access point or an AirPort Extreme (or AirPort) base station, and one or more computers with wireless network cards or adapters.

Configuring the Projector

1. Press the Menu button, then choose **Network** and press Enter.
2. Choose **Network Configuration** and press Enter.
3. Choose **Wireless LAN** and press Enter. You see this screen:



4. Make sure **Wireless LAN Power** is set to **On**. You can turn it off to prevent unauthorized access.
5. Select one of the following connection modes:
 - **Quick mode** lets you easily connect one computer to the projector at a time. You can also select this setting when you're using the optional Epson Quick Wireless Connection USB key.
 - **Advanced mode** lets multiple computers access the projector at the same time and easily trade off control of the projector. This method requires a wireless network access point or an AirPort Extreme (or AirPort) base station.

6. If your network is using 802.11b/g, use the  pointer button on the remote control to select a **Channel** setting. If interference occurs, select a different channel.
7. If your network is using 802.11a, use the  pointer button on the remote control to highlight **802.11a**, then press **Enter** to select it.
8. If you are connecting in Quick mode, you can set **SSID Auto Setting** to **On** to find the projector faster and create a more stable connection. Skip step 9 if you activate this setting. Select **Off** if you are connecting to multiple projectors from a single computer.
9. Highlight the **SSID** text box, press **Enter**, and enter the name you want to assign to the projector (Quick mode), or the name of your existing wireless network (Advanced mode):

Use the arrow buttons to select individual letters, then press **Enter** to input a character. To add a blank space or to navigate backward and forward through the input text, highlight the arrows and press **Enter**. To toggle symbol settings or capital letters, highlight the option and press **Enter**. When you're done, highlight **Finish** and press **Enter**.



Note that the SSID is case-sensitive (if you enter the name in uppercase on the projector, you must type it the same way on the computer connecting to the projector).

10. Do one of the following:
 - If your network assigns addresses automatically, turn on the DHCP setting.

note

For specific details about your network, please consult your network administrator.

If you're using AirPort, start the AirPort Admin utility, select your base station and click Configure. Then click the Network tab to see your base station's IP address.

- If your network does not assign addresses automatically, turn off DHCP and enter the projector's IP Address, Subnet Mask, and Gateway Address, as needed.

To enter numbers, use the arrow buttons on the remote control to select each number on the screen, then press the Enter button. When you're finished entering an address in the network menu, highlight Finish, then press the Enter button.

11. If you want to prevent the SSID from being displayed on the standby screen, set the SSID Display option to Off.
12. To prevent the IP address from appearing on the standby screen, set the IP Address Display setting to Off.
13. When you're done making these settings, press Esc. Highlight the Return button at the top of the screen, then press Enter. Choose Complete and press Enter, then choose Yes and press Enter to save your settings.

Now you're ready to select the wireless network your computer, as described in the next section.

Selecting Wireless Network Settings in Windows

Before connecting to the projector, select the correct wireless network on your computer.

1. To access your wireless utility software, double-click the network icon on the Windows taskbar.
2. Do one of the following:
 - If your projector is set up on an existing network (Advanced mode), select the network name (SSID).
 - If your projector is configured for Quick mode, select the SSID you assigned to the projector.
3. Click Connect.

Now you're ready to connect to the projector. See the *EasyMP Network Projection Operation Guide* for details.

note

Settings may vary, depending on your wireless network adapter. See the documentation for your adapter for more information.

Selecting Wireless Network Settings in Mac OS

Before connecting to the projector, select the correct wireless network on your computer.

1. Click the AirPort icon on the menu bar at the top of the screen.
2. Make sure AirPort is turned on, then do one of the following:
 - If your projector is set up on an existing network (Advanced mode), select the network name (SSID).
 - If your projector is configured for Quick mode, select the SSID you assigned to the projector.

Making a WPS (Wi-Fi Protected Setup) Connection

If you are using a WPS-compatible access point, you can configure the settings for the connection between the projector and the access point from the projector's Configuration menu using one of these methods:

- **Push Button Method**
Press both the **Enter** button on the projector and the button on the access point to make the SSID and security settings. This method is recommended when the projector and access point are close together.
- **PIN Code Method**
With the PIN code method, you enter an 8-digit code from the computer to enable the SSID and security settings. The connection between the computer and the access point must have already been established. (For connection instructions, refer to the manual provided with the access point.) This method lets you make the settings without having to press any buttons on the projector, and is recommended when the projector is mounted on the ceiling.

Follow these steps to open the WPS connection screen:

1. Press the **Menu** button, then choose **Network** and press **Enter**.
2. Choose **Network Configuration** and press **Enter**.

3. Choose Wireless LAN and press Enter. You see this screen:



4. Select To Setup Wizard, then press Enter. You see the WPS (Wi-Fi Protected Setup) connection screen:

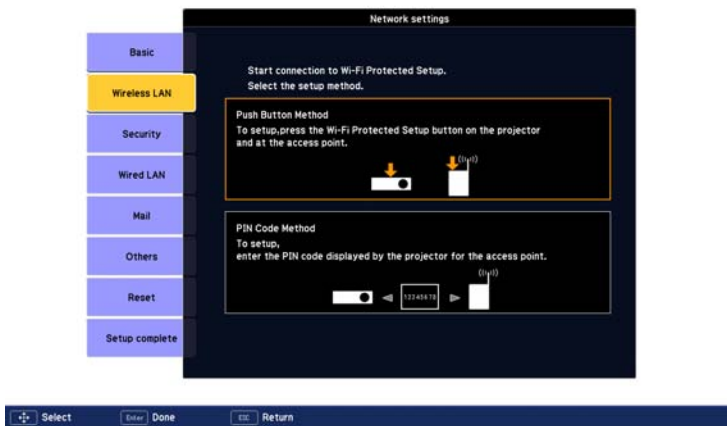

5. For the Push Button Method, follow the instructions on page 87. For the PIN Code Method, follow the instructions on page 88.

Using the Push Button Method

1. Select Push Button Method and press Enter. You see this screen:

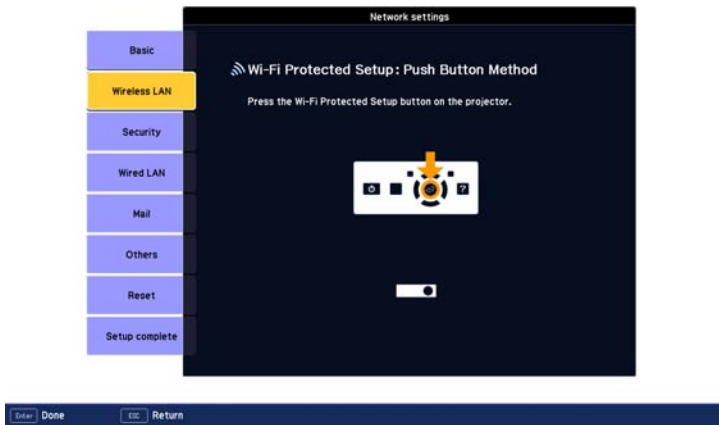

2. Press the Enter button on the projector.
3. When prompted by the screen, press the WPS button on the access point.

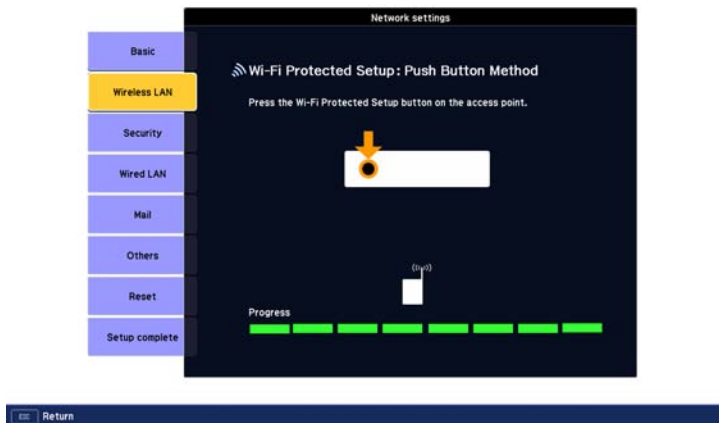

You see a message that WPS setup is complete.

4. Press the Enter button or the Esc button to return to the wireless LAN setting page.

5. Select **Setup Complete** and press **Enter**.



6. Make sure **Yes** is selected and press **Enter**.
7. Press the **Menu** button.

Using the PIN Code Method

Before you can make a connection using the PIN Code Method, a connection must have already been established between the computer and the access point. For details on how to make this connection, refer to the manual provided with the access point.

1. Follow steps 1 through 4 beginning on page 85 to access the WPS Connection Screen.

2. Select PIN Code Method and press Enter. You see this screen:



3. From the computer, enter the displayed PIN code for the access point, select **Start Setup** and then press **Enter**.

You see a progress meter on the screen.

4. When you see a message that WPS Setup is complete, press the **Enter** or **Esc** button.

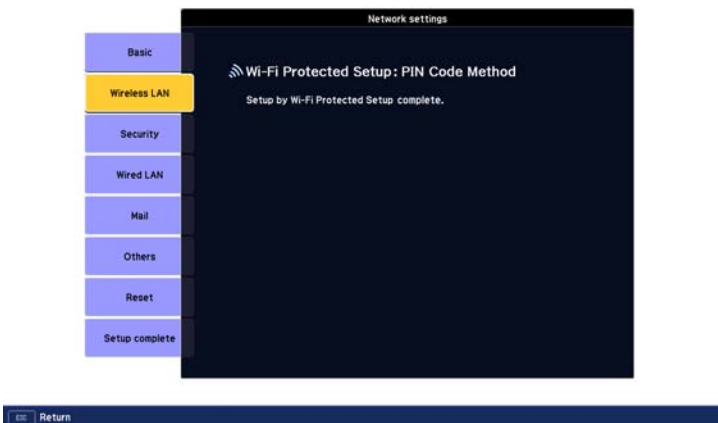

5. When you see the wireless LAN setting page, select **Setup Complete** and press **Enter**. You see this screen:



6. Select **Yes** and press **Enter** to save the settings.
7. Press the **Menu** button and then close the configuration menu to exit.

Using Wireless Security Options

If you have installed the optional Wireless 802.11g/b/a Module, you can use the following security options when connecting to the projector wirelessly: WEP encryption, WPA security, EAP-TLS certificate validation, or LEAP, EAP, or PEAP authentication. To set these security features on your wireless network, see your documentation or get help from your network administrator. See the following sections to enable the security option on your projector:

- “Enabling WEP Encryption” on page 91
- “Enabling WPA Security” on page 93
- “Enabling EAP, LEAP, or PEAP Authentication” on page 94
- “Enabling EAP-TLS Certificate Validation” on page 95

Enabling WEP Encryption

1. Press Menu, then highlight Network and press Enter.
2. Choose Network Configuration and press Enter.
3. Highlight Security and press Enter. Then press Enter again to display the security options:

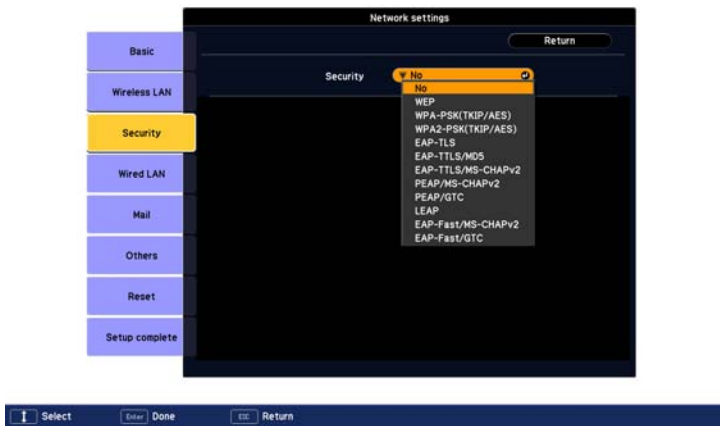

4. Highlight WEP and press Enter.
5. For the WEP encryption setting, highlight 128Bit or 64Bit and press Enter.
6. For Format, highlight ASCII to enable text input or HEX to enable hexadecimal input. Then press Enter.
7. If you chose 64Bit, choose Key ID 1, 2, 3, or 4.

note

Text input for WEP encryption varies with different access points; check with your network administrator. Try ASCII first. If that doesn't work, try Text2 and then Text3.

Highlight the **Encryption key** text box that corresponds to the Key ID you selected, then press **Enter**. Press the  pointer button to select individual letters, then press **Enter** to input a character. To navigate backward and forward through the input text, highlight the arrows and press **Enter**. To toggle symbol settings or capital letters, highlight the option and press **Enter**. When you're done, highlight **Finish** and press **Enter**.



8. Check with your network administrator for directions on entering a key for your network, and follow these general guidelines:
 - For 128 bit WEP encryption with hexadecimal input, enter 26 characters, from 0 to 9 and from A to F.
 - For 64 bit WEP encryption with hexadecimal input, enter 10 characters, from 0 to 9 and from A to F.
 - For 128 bit WEP encryption with ASCII or text input, enter 13 alphanumeric characters.
 - For 64 bit WEP encryption with ASCII or text input, enter 5 alphanumeric characters.
9. When you're done making these settings, select **Return**, **Setup complete**, and then **Yes** to confirm that you want to save the changes.
10. Press **Menu** to exit.

Enabling WPA Security

1. Press **Menu**, then highlight **Network** and then press **Enter**.
2. Choose **Network Configuration** and press **Enter**.
3. Highlight **Security** and press **Enter**. Then press **Enter** again to display the security options:

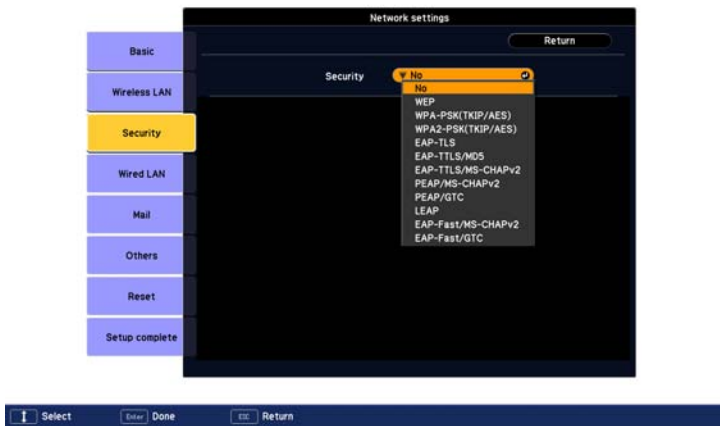

4. Choose **WPA-PSK(TKIP/AES)** or **WPA2-PSK(TKIP/AES)** and press **Enter**.

Highlight the **PSK** (pre-shared key) text box and press **Enter**. Press the  pointer button to select individual letters, then press **Enter** to input a character. To navigate backward and forward through the input text, highlight the arrows and press **Enter**. To toggle symbol settings or capital letters, highlight the option and press **Enter**. When you're done, highlight **Finish** and press **Enter**.



5. When you're done making these settings, select **Return**, **Setup complete**, and then **Yes** to confirm that you want to save the changes. Press **Menu** to exit.

note

You can enter up to 32 characters when you use the projector's menu. If you enter the pre-shared key using a web browser (see page 101), you can enter up to 63 characters.

Enabling EAP, LEAP, or PEAP Authentication

1. Press Menu, then highlight Network and then press Enter.
2. Choose Network Configuration and press Enter.
3. Highlight Security and press Enter. Then press Enter again to display the security options:

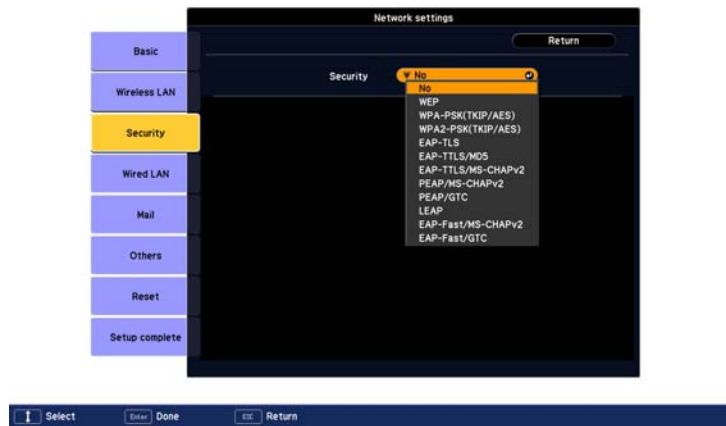

note

You can enter up to 32 characters when you use the projector's menu. If you enter the user name and password using a web browser (see page 101), you can enter up to 64 characters.

4. Choose EAP-TTLS/MD5, EAP-TTLS/MS-CHAPv2, PEAP/MS-CHAPv2, PEAP/GTC, LEAP, EAP-Fast/MS-CHAPv2, or EAP-FAST/GTC. Then press Enter.
5. Enter the user name and password that match the settings on your authentication server.

Highlight the User name text box and press Enter. Press the  pointer button to select individual letters, then press Enter to input a character. To add a blank space or to navigate backward and forward through the input text, highlight the arrows and press Enter. To toggle symbol settings or capital letters, highlight the option and press Enter. When you're done, highlight Finish and press Enter.



Highlight the **Password** text box and press **Enter**. Enter the password as you entered the **User name**.

- When you're done making these settings, select **Return, Setup complete**, and then **Yes** to confirm that you want to save the changes.
- Press **Menu** to exit.

Enabling EAP-TLS Certificate Validation

Once you have created an EAP-TLS certificate, follow the steps below to enable it. (Contact your Network Administrator for more information on obtaining or creating the certificate.)

For information on registering a certificate to the projector, see the *PC Free Operation Guide*.

- Press **Menu**, then highlight **Network** and then press **Enter**.
- Choose **Network Configuration** and press **Enter**.
- Highlight **Security** and press **Enter**. Then press **Enter** again to display the security options:

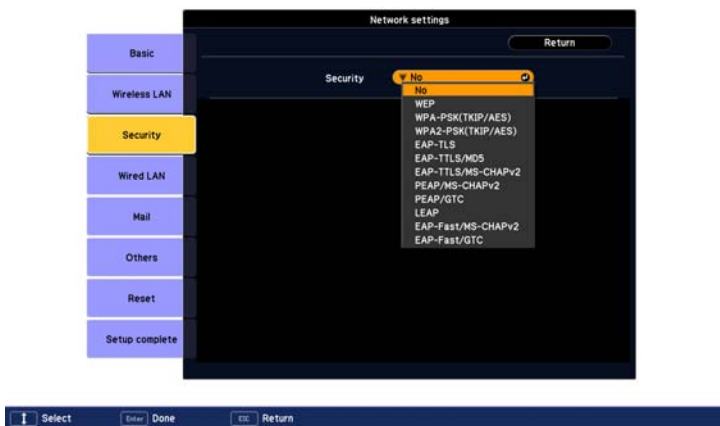

- Choose **EAP-TLS** and press **Enter**. The certificate information appears on the screen.
- When you're done, select **Return, Setup complete**, and then **Yes** to confirm that you want to save the changes.

6. Press **Menu** to exit.

Enabling Data Encryption from EasyMP Network Projection

When using the EasyMP Network Projection software, follow these steps to enable data encryption.

1. Click **Set options** on the main screen.
2. Click the **General settings** tab.
3. Select the **Encrypt communications** checkbox.
4. Click **OK**.

For more information, see the *EasyMP Network Projection Operation Guide*.

Using the EasyMP Network Projection Software

Once you've set up your projector and computer for network projection, see the *EasyMP Network Projection Operation Guide* for instructions on the following EasyMP features:

- Starting EasyMP Network Projection
- Projecting over the network (content over IP)
- Multi-screen projection
- Using Presentation mode
- Connecting to a projector on a different subnet

Removing the Wireless 802.11g/b/a Module

Follow these steps to remove the module from your projector.

1. If you're running EasyMP Network Projection, click **Disconnect** on the control bar.



2. Check the access light to make sure it isn't flashing.

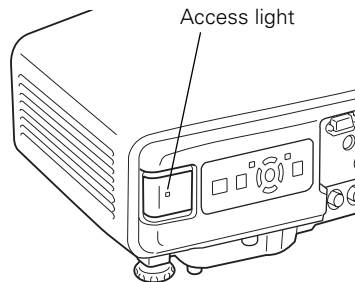

3. Turn off the projector and unplug it.

caution

Never remove the module while its access light is green or when projecting wirelessly. You may damage the module.

4. Unscrew the module, then pull it out.

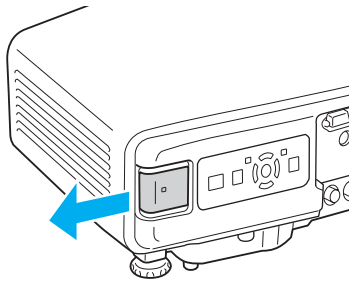
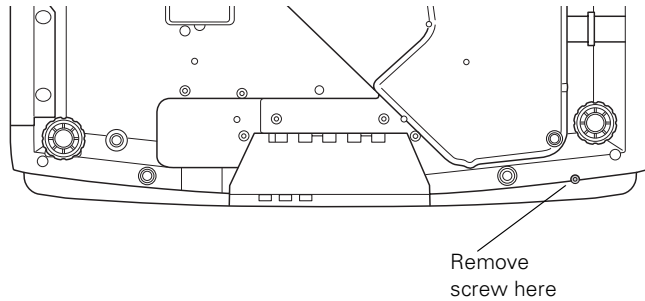

Using Projector E-mail Alerts

When this feature is enabled, the projector sends you an e-mail alert if it has any problems.

1. Press the **Menu** button, select the **Network** menu, then press **Enter**.
2. Choose **Network Configuration** and press **Enter**.

note

You can also set e-mail alerts from EasyMP Monitor (available for Windows only). See the EasyMP Monitor Operation Guide for more information.

3. Choose **Mail**, then press **Enter**. You see a screen like this:



4. Highlight **On** to receive e-mail notifications, then press **Enter**.
5. Enter the IP address for the **SMTP** server for the projector.
You can enter a number from 0 to 255 in each field of the address. However, the following IP addresses cannot be used: 127.x.x.x, 224.0.0.0 to 255.255.255.255 (where x is a number from 0 to 255).
6. Enter the **SMTP** server's port number. The default value is 25. You can enter a numeric value from 1 to 65535.
7. Choose one of the **Email Address** fields, then enter the e-mail address where you want to receive a message when a problem occurs. You can register up to three addresses. You can enter up to 32 alphanumeric characters for the e-mail address.
8. Select problems or warnings to be notified about by e-mail using the **Setting a Notification Event** section. (Numbers 1 through 3 in this section correspond to the e-mail addresses you entered.)
9. When you're done making all necessary changes, highlight the **Return** button at the top of the screen, then press **Enter**. Choose **Setup complete** and press **Enter**, then choose **Yes** and press **Enter** to save the changes.
10. Press **Menu** to exit.

note

If a critical problem develops with a projector which causes it to suddenly stop working, it may not be possible for the projector to send a message.

If Standby Mode is set to Communication On in the Extended menu, the projector can still be monitored even if the projector is in standby mode (when the power is off but the projector is still connected to power and the network).

When the selected problem or warning occurs, an e-mail message is sent to the specified notification addresses. The subject line of the e-mail is **EPSON Projector**. The e-mail includes the following information:

- Line 1: The name of the projector where the problem has occurred
 - Line 2: The IP address of the projector where the problem has occurred
 - Line 3: Details of the problem
11. When you're done making all necessary changes, select **Return**, select **Setup complete**, and then select **Yes** to confirm that you want to save the changes. Press **Menu** to exit the menu system.

Using SNMP to Monitor the Projector

Network administrators can use SNMP (Simple Network Management Protocol) to monitor projectors.

1. Press the **Menu** button, select the **Network** menu, then press **Enter**.
2. Choose **Network Configuration** and press **Enter**.
3. Choose **Others** and press **Enter**. You see the following screen:

note

If you're a network administrator, you can use the SNMP option to enter a trap IP address. This lets you receive trap alerts for the projectors you're monitoring.



4. Turn on the **SNMP** setting.
5. Enter up to two IP addresses for notification.

You can enter a number from 0 to 255 in each field of the address. However, the following IP addresses cannot be used: 127.x.x.x, 224.0.0.0 to 255.255.255.255 (where x is a number from 0 to 255).
6. For **Priority Gateway**, select **Wired** or **Wireless**.
7. If your network environment uses an AMX controller, select **On** to allow the projector to be detected by AMX Device Discovery.
8. When you're done making all necessary changes, highlight the **Return** button at the top of the screen, then press **Enter**. Choose **Setup complete** and press **Enter**, then choose **Yes** and press **Enter** to save the changes.
9. Press **Menu** to exit.

Using a Browser to Control the Projector

You can use a standard web browser to monitor and control the projector through the network.

1. Make sure that the projector is set up for your network, as described on page 76 (for a wired connection) or page 81 (for a wireless connection).
2. Open your web browser and enter the IP address of the projector you want to monitor in the browser window.

If you're not sure what the address of the projector is, turn the projector on and select **Net. Info.-Wired LAN** or **Net. Info.-Wireless LAN** from the Network menu to display the IP address of the projector. Do not enter leading zeroes.

3. Press **Enter**, or, if you set a Web control password in the projector's Network menu, enter the user name **EPSONWEB** and your password, then press **Enter**.

note

When using a browser to access the projector, you cannot connect through a proxy server.

*When using a browser to access the projector over a wireless connection, use **Advanced Mode** (see page 81).*

*Standby Mode in the **Extended** menu should be set to **Communication On** to monitor the projector in standby mode.*

4. Select one of the menu options listed on the screen, then change any of the settings as needed. These settings correspond to those found in the projector's menu system.

You cannot change the following settings using a web browser:

- Quick Corner, Pointer Shape, Test Pattern, or User Button in the Settings menu
- User's Logo, High Altitude Mode, BNC Sync Termination, Remote Control Type, and Language in the Extended menu
- Any settings in the Reset menu
- Any settings related to the Power On Protect, User's Logo Protect, or Network Protect passwords

You can only change the following settings using a web browser:

- Community Name
- Monitor password

Using Web Remote Control

When you access the projector through your browser, you can display a "virtual remote control" on your computer screen. This lets you change sources and perform many of the same functions as you can with the physical remote control.

From the Projector Control menu, select **Web Remote**. You see the following screen:

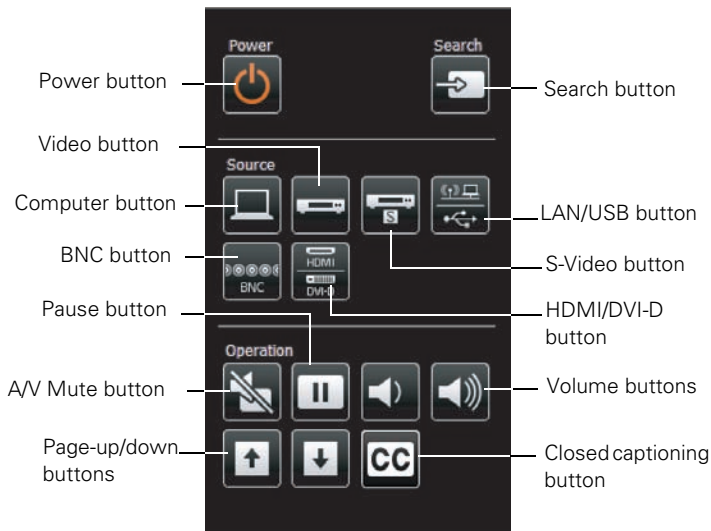

- The **Power** button turns the projector on and off.
- The **Search** button searches for signal sources (see page 56).
- The **Computer** button changes the input source to **Computer1** (PowerLite G5450WUNL/G5750WUNL) or, with the PowerLite G5550NL/G5650WNL/G5950NL, selects a computer signal (connected to the **Computer1** or **Computer2** port).
- The **Video** button selects a video signal (connected to the **Video1** or **Video2** port).
- The **S-Video** button changes the input source to **S-Video**.
- The **LAN/USB** button selects a network signal or a signal from equipment connected to the  USB port on the projector.
- The **BNC** button changes the input source to **BNC**.
- The **HDMI/DVI-D** button changes the input source to **HDMI** (G5550NL/G5650WNL/G5950NL), or selects a signal from equipment connected to the **HDMI** or **DVI-D** port on the projector (G5450WUNL/G5750WUNL).

- The A/V Mute button temporarily turns off the picture and sound (see page 67).
- The Pause button stops the image (see page 67).
- The Volume buttons raise or lower the volume.
- The Page-up/down buttons change slides when you project a slideshow over a network or from a device connected to the USB port. 
- The CC (Closed Captioning) button lets you display closed captioning for content that provides it.

Using Crestron RoomView to Monitor and Control the Projector

You can use Crestron RoomView to monitor and control the projector through the network.

Setting up the Projector

1. Press the Menu button, select the Network menu, then press Enter.
2. Choose Network Configuration and press Enter.

note

You cannot use the web browser control described on page 101 or the Message Broadcasting plug-in (see page 12) while you are using Crestron RoomView.

Standby Mode in the Extended menu should be set to Communication On to monitor or control the projector in standby mode.

When accessing the projector over a wireless connection, use Advanced Mode (see page 81).

3. Choose **Others** and press **Enter**. You see the following screen:



4. Turn on the RoomView setting.
5. Highlight the **Return** button at the top of the screen, then press **Enter**. Choose **Setup complete** and press **Enter**, then choose **Yes** and press **Enter** to save the changes.
6. Press **Menu** to exit.
7. Turn the projector off and then on again. The setting change will take effect once the projector restarts.

Using a Browser to Control the Projector

You can use a standard web browser to monitor and control the projector through the network.

1. Make sure that the projector is set up for your network, as described on page 76 (for a wired connection) or page 81 (for a wireless connection).

note

If you're not sure what the IP address of the projector is, turn the projector on and select Net. Info.-Wired LAN or Net.

Info.-Wireless LAN from the Network menu to display the address. Do not enter leading zeroes.

2. Open your web browser and enter the IP address of the projector you want to monitor in the browser's address box. You see a window like this:





toolbar

3. Select options on the screen as necessary:
 - To turn the projector on or off, click the **Power** button.
 - To raise or lower the volume, click the **Vol+** and **Vol-** buttons.
 - To temporarily turn off the picture and sound, click the **A/V Mute** button (see page 67).
 - To select an input source, click it in the **Sources List**. To scroll through the list, click the arrow bars at the top or bottom of the list.
 - To pause or unpause an image, click the **Freeze** button in the toolbar.
 - To adjust the contrast, click the **Contrast** button in the toolbar.
 - To adjust the image brightness, click the **Brightness** button in the toolbar.
 - To adjust the color saturation, click the **Color** button in the toolbar.

note

The toolbar buttons are not all visible at the same time. To scroll through the toolbar buttons, click the arrow buttons on the left or right side of the toolbar.

- To adjust the image sharpness, click the **Sharpness** button in the toolbar.
 - To enlarge the image without changing the projection size, click the **Zoom** button in the toolbar. Then click the  button to enlarge the image or the  button to reduce an image that was enlarged with the  button. Click the arrow buttons the change the position of an enlarged image.
4. Use the following buttons in place of the buttons on the projector's remote control:

Crestron RoomView button	Remote control button
OK	Enter
Menu	Menu
Auto	Auto (see page 117)
Search	Search (see page 66)
Esc	Esc

Additionally, the arrow buttons in the Crestron RoomView window can be used in place of the  pointer button on the remote control.

5. Select the **Info** tab in the top right corner of the window to display information about the projector.
6. Select the **Contact IT Help** tab in the top right corner of the window to display the Help Desk window, which can be used to send messages to and receive messages from an administrator using Crestron RoomView Express.

Using the Tools Tab

Select the Tools tab in the top right corner of the window to display the window shown below:

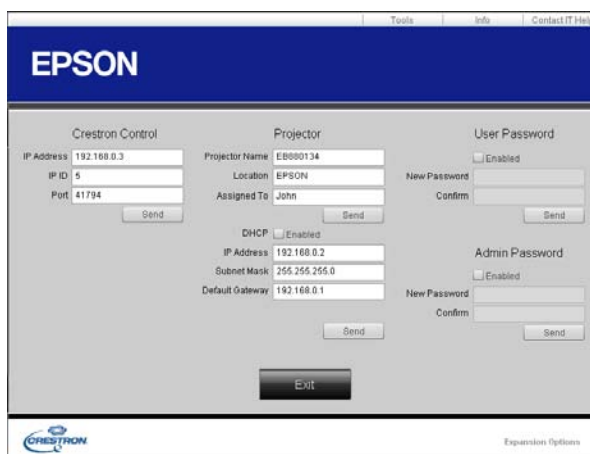

The screenshot shows the Epson Crestron Control interface with the 'Tools' tab selected. The interface is divided into three main sections: Crestron Control, Projector, and User Password. The Crestron Control section includes fields for IP Address (192.168.0.3), IP ID (5), and Port (41794), with a 'Send' button. The Projector section includes fields for Projector Name (EB880134), Location (EPSON), and Assigned To (John), with a 'Send' button. Below these are DHCP settings: a checkbox for 'Enabled' (checked), IP Address (192.168.0.2), Subnet Mask (255.255.255.0), and Default Gateway (192.168.0.1), with a 'Send' button. The User Password section includes fields for New Password and Confirm, with a 'Send' button. Below the Projector section are Admin Password fields: a checkbox for 'Enabled' (checked), New Password, and Confirm, with a 'Send' button. An 'Exit' button is located at the bottom center. The Epson logo is in the top left, and the Crestron logo is in the bottom left. The text 'Expansion Options' is in the bottom right.

1. Enter settings for Crestron® central controllers in the **Crestron Control** section of the window.
2. Enter settings in the **Projector** section of the window:
 - Enter a **Projector Name** to differentiate the current projector from other projectors on the network (up to 15 single-byte alphanumeric characters).
 - Enter a **Location** name for the projector (up to 32 single-byte alphanumeric characters).
 - Enter a user name for the projector in the **Assigned To** box (up to 32 single-byte alphanumeric characters).
 - Click the **Enabled** checkbox to use DHCP.
 - If you're not using DHCP, enter an **IP Address** for the projector.
 - Enter a **Subnet Mask** and **Default Gateway** address for the projector.
3. Click **Send** to register the changes you made in the **Projector** section of the window.

4. To require a password for access to the initial Crestron RoomView window, click **Enable** in the **User Password** section of the window, enter a password (in both the **New Password** and **Confirm** boxes), and click **Send**.
5. To require a password for access to the **Tools** tab, click **Enable** in the **Admin Password** section of the window, enter a password (in both the **New Password** and **Confirm** boxes), and click **Send**.
6. When you're through making settings on the **Tools** tab, click **Exit**.

note

Passwords you enter in the User Password or Admin Password window sections can contain up to 26 single-byte alphanumeric characters.

5 *Fine-Tuning the Projector*

You can use the projector's on-screen menus to adjust the image, sound, and other features. This chapter covers the following information:

- Using the menu system
- Adjusting the image
- Adjusting signal settings
- Customizing projector features
- Using the projector security features
- Customizing power and operation
- Multi-screen color adjustment
- Projector Menu and Options List

Using the Menu System

You can use the remote control or the projector's control panel to access the menus and change settings. Follow these steps:

1. To display the menu screen, press the **Menu** button on the remote control or on the projector.

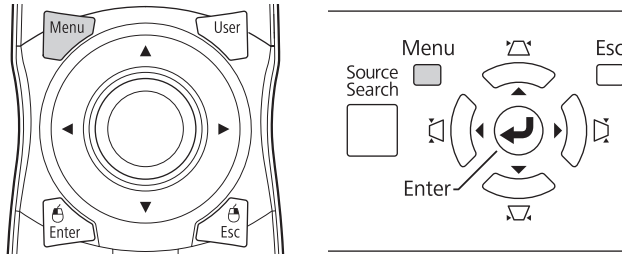

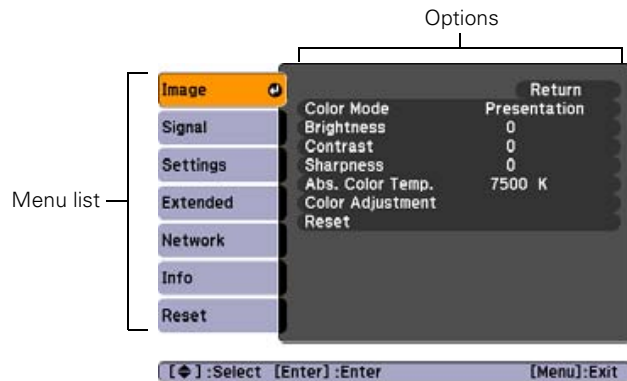

You see a menu screen similar to the one below:





note

For a complete list of menus and options, see page 129. For more information on these menus and options, continue reading this chapter.

The menus are listed on the left and the options available for the highlighted menu are shown on the right.

2. Use the  pointer button on the remote control (or the navigational buttons on the projector) to scroll through the menu list. When you've highlighted the desired menu, press the **Enter** button to select it.
3. Once you've selected the menu, use the  pointer button to scroll through the list of options. (Some of the options may be grayed out or unavailable, depending on the selected source.)

4. After highlighting the option you want to adjust, use the  pointer button to change the setting. In some cases, you may have to press the **Enter** button to view a sub-screen for changing the setting.
 - Press the left or right side of the  pointer button to adjust a slider bar.
 - To select from two or more settings, use the  pointer button to highlight the desired setting and press **Enter**.
5. After changing the settings, press the **Esc** button to save your changes and return to the previous menu (or press it repeatedly to exit the menu system).



You can also press the **Menu** button to exit.

Restoring the Default Settings

You can use the menu system's **Reset** options to restore the factory-default settings for all the settings listed in a specific menu, or all the settings in all menus.

To restore the settings in a specific menu, enter the menu whose settings you want to change, select **Reset**, and confirm as needed. (The example below shows how to reset the Image menu.)

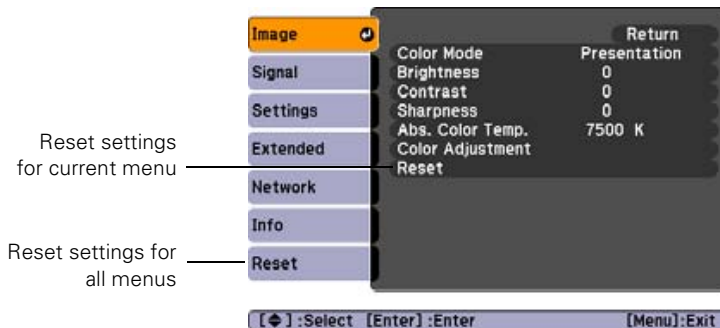

note

*When you select **Reset All** in the **Reset** menu, it does not reset the Input Signal, User's Logo, Multi-screen, Language, Lamp Hours, or Network settings.*

To restore all the projector settings to their factory-default values, select the **Reset** menu, highlight **Reset All**, and press **Enter**.

Adjusting the Image

You can use the Image menu to adjust the brightness, sharpness, color, tint, and contrast.

1. Press the **Menu** button on the projector or remote control and select the **Image** menu.

You see a screen similar to one of those below. (The settings will be different depending on the source you are projecting from.)

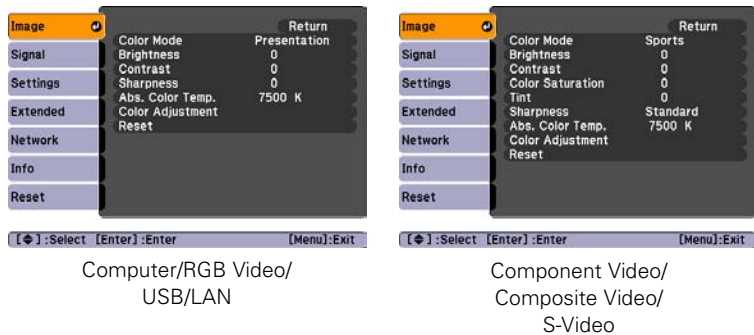

note

The available settings vary depending on the input source selected.

2. Use the  pointer button to highlight the desired option, then adjust it as needed:

- **Color Mode**

Lets you quickly adjust the color and brightness for various environments. Use either the remote control or the **Color Mode** setting in the Image menu. You can save a different setting for each source. See page 60 for more information on each color mode.

- **Brightness**

Lightens or darkens the overall image.

- **Contrast**

Adjusts the difference between light and dark areas.

- **Color Saturation**

Adjusts the color depth of the image.

- **Tint**

Adjusts the balance of green to magenta in the image.

note

*The **Brightness** setting changes the opacity of the projector's LCD panels. You can also use the **Power Consumption** setting to change the lamp's brightness (see page 119).*

■ Sharpness

Adjusts the sharpness of the image.

If you select **Advanced**, you can access more detailed settings: Adjust **Thin Line Enhancement** to enhance or soften objects like hair or fabric patterns. Adjust **Thick Line Enhancement** to enhance or soften outlines of objects or backgrounds. Adjust **Vert. Line Enhancement** to enhance vertical lines in the image. Adjust **Horiz. Line Enhancement** to enhance horizontal lines in the image.

■ Abs. Color Temp.

Sets a color temperature between 5000 and 10000 °K. (Not available if **sRGB** is selected as the Color Mode setting.)

■ Color Adjustment

Adjusts the color values. For **Customized** color mode, select **R, G, B, C, M, Y** to adjust individual red, green, blue, cyan, magenta, and yellow hue, saturation, and brightness values. For other color modes, **RGB** may be selected to adjust red, green, and blue saturation values. (Not available if **sRGB** is selected as the Color Mode setting.)

Six-Axis Color Adjustment

For special projection material, such as high-quality photographs or artwork, you can adjust the hue, saturation, and brightness for six different color axes.

1. Follow the instructions on page 114 to open the Image menu and select **Color Mode**.
2. Press the **Enter** button to select **Customized**, then press **Esc** to return to the Image menu.
3. Select **Color Adjustment** and press **Enter**. You see hue, saturation, and brightness controls on the screen for six colors: **R, G, B, C, M, Y** (red, green, blue, cyan, magenta, and yellow).
4. Select the color axis you want to adjust and press **Enter**. You see color controls for hue, saturation, and brightness.

Hue changes the balance of color, and saturation changes the strength of the color.

note

You cannot adjust the advanced Sharpness settings if the input signal is RGB or if the input source is  USB or LAN.

5. Use the  pointer button to adjust the hue, saturation, and brightness. You see the adjustments reflected on the screen. When you are satisfied with the color, press **Esc**.
6. Repeat steps 4 and 5 for each color axis you want to adjust.

You may need to readjust the color as the lamp in your projector changes over time.

Adjusting Signal Settings

Although the projector normally detects and optimizes the input signal automatically, you can use the Signal menu to make manual adjustments. In addition to changing the position of the projected image, you can correct tracking and sync for computer images, or change the aspect ratio to widescreen format for video images.

1. Press the **Menu** button and select the **Signal** menu.

You see a screen similar to one of those below. (The settings will be different depending on the source you are projecting from.)

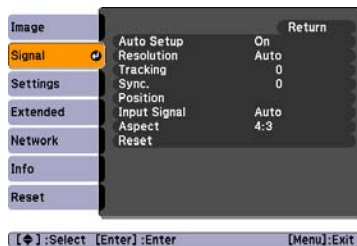

Computer/RGB Video

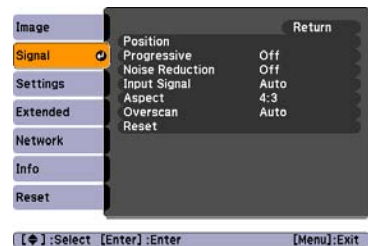

Component Video

2. Use the  pointer button to highlight the desired option, then adjust it as needed:
 - **Auto Setup**
Leave this setting **On** to automatically optimize computer images. Turn it off if you want to save adjustments you have made to the Tracking, Sync, and Position settings.

■ Resolution

Set to **Auto** to have the projector automatically identify the resolution of the input signal. If necessary (because some of the image is missing, for example), adjust to **Wide** or **Normal**. You can also select **Manual** and specify a resolution.

■ Tracking

Adjust this value to eliminate vertical stripes in computer images.

■ Sync

Adjust this value if computer images appear blurry or flicker.

■ Position

If the image is slightly cut off on one or more sides, it may not be centered exactly. Select this setting and use the  pointer button to center it.

■ Progressive

For composite video, S-Video, component video, and signals from the HDMI port only. Turn this setting on to convert interlaced signals into progressive signals (best for still images). Select **Video** for viewing general video images. Select **Film/Auto** for movie images, CG, and animated images. Leave the setting **Off** for moving images.

■ Noise Reduction

Smooths out rough images. Select the setting that makes the selected input source look best. Epson recommends that you select **Off** when viewing image sources with very low noise, such as DVDs.

■ HDMI Video Range (G5550NL/G5650WNL/G5950NL only)

When you connect to the HDMI input port, set the projector's video range to match the video range setting of your device.

■ DVI/HDMI Video Range (G5450WUNL/G5750WUNL only)

When you connect to the DVI-D or HDMI input port, set the projector's video range to match the video range setting of your device.

note

*You can also use the remote control's **Auto** button to automatically reset the projector's Tracking, Sync, and Position settings. See page 155 for details.*

note

For component or RGB video, the Progressive setting can only be adjusted when 480i/576i/1080i signals are being input. However, the setting cannot be adjusted with 1080i signals when the Aspect setting is Full.

note

The Noise Reduction, Progressive, and Overscan settings cannot be set for digital RGB signals.

- **Input Signal**
If the colors don't look right on the **Auto** setting, select the setting for the type of equipment you've connected to the **Computer1**, **Computer2** (G5550NL/G5650WNL/G5950NL only), or **BNC** ports. Choose **RGB** for a computer or RGB-video connection, and **Component** for a video player that outputs a component video signal (with connectors labeled Y/Cb/Cr or Y/Pb/Pr).
- **Video Signal**
Select the setting for the type of equipment you've connected to the **Video1**, **Video2**, or **S-Video** ports. Leave this setting at **Auto** unless you are using a 60-Hz PAL system (then select **PAL60**).
- **Aspect**
Sets the image's aspect ratio (ratio of width to height). Depending on your projector model and input source, you can select **Auto**, **Normal**, **4:3**, **16:9**, **Full**, **Zoom**, or **Native**; see page 61 for more information.
- **Overscan**
Allows you to reduce the image size slightly when the edges of the image are not visible. The range of trimming can be set to **Off**, **4%**, or **8%**. You can select **Auto** only when the input source is **HDMI**. When **Auto** is selected, the range is automatically switched to **Off** or **8%** according to the input signal.
- **2-2 Pull-down** (G5450WUNL/G5750WUNL only)
Projects 24 frames per second images at their original frame rate without interpolation. This can be set only when 1080p/24Hz signals are being input.

Customizing Projector Features

You can use the Settings menu to lock the buttons on the projector, adjust audio volume, and customize several other features.

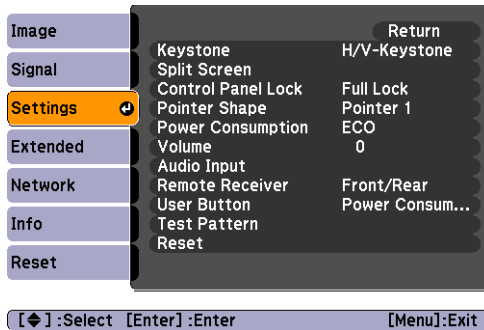

■ Keystone

Adjusts the shape of the image if the projector has been tilted upward or placed at an angle to the screen.

Select **H/V-Keystone** to correct horizontal and vertical keystone distortion.

Select **Quick Corner** to adjust the shape and position of the projected image.

■ Split Screen

Lets you divide the screen into two parts and show two input sources at the same time. See page 62 for more information.

■ Control Panel Lock

Lets you disable all of the buttons on the projector, or all of the buttons except the  power button. See page 125 for more information.

■ Pointer Shape

Lets you choose from three pointer shapes. See page 69 for more information.

■ Power Consumption

Lets you select from two levels of brightness. The **ECO** setting reduces power consumption and noise, and extends the lamp's operating life.

note

You can also adjust the volume using the remote control.

- **Volume**
Raises or lowers the volume.
- **Audio Input**
Lets you select the input port to use for audio when your video input is LAN. With the PowerLite G5550NL/G5650WNL/G5950NL, you can also select an audio input port when your video input is HDMI.
- **Remote Receiver**
Deactivates the projector's front and/or back sensors that detect signals from the remote control. Use this setting to prevent use of the remote control or to stop interference from bright fluorescent lights.
- **User Button**
You can assign one of the following six menus to the User button: **Power Consumption**, **Info**, **Progressive**, **Test Pattern**, **Multi-screen**, or **Resolution**. By pressing the button, the assigned menu item selection/adjustment screen is displayed, allowing you to make one-touch settings/adjustments.
- **Test Pattern**
Displays a test pattern for use when adjusting the zoom, focus, image position, **Color Mode**, **Brightness**, **Sharpness** (standard only), **Abs. Color Temp**, **Color Adjustment**, and when performing keystone correction.

Press the  pointer button on the remote control to the left or right or press the **Enter** button on the projector to change the test pattern. Press the **Esc** button to clear the test pattern.

Using the Projector Security Features

To prevent unauthorized use of the projector, you can do the following:

- Assign a password. You can use the password to prevent the projector from being turned on, prevent your custom startup screen from being changed, and lock network settings.
- Create a custom screen that is displayed at startup and/or when the **A/V Mute** button is pressed. The screen can be locked with a password to discourage theft and provides a way to identify the projector should it be stolen. See page 123.
- Disable the projector's buttons; this is useful, for example, if you're projecting in a classroom and you want to ensure that no one touches the projector's buttons while you're using the remote control. See page 125.

Enabling Password Protection

The default setting for the password is 0000. Follow these steps to create a new password:

1. Press the **Freeze** button on the remote control for about five seconds. You see this screen:

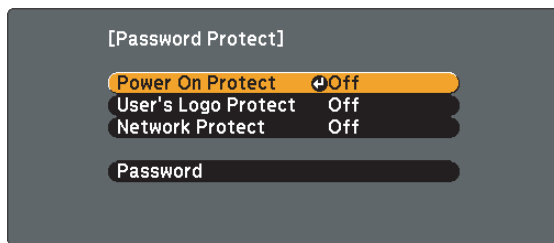

2. Use the  pointer button to select **Password** and press **Enter**.
3. When you see a message asking if you want to change the password, select **Yes** and press **Enter**.

note

You can also attach a security cable to the projector to prevent theft (see page 164).

caution

If you lose the remote control, you will not be able to enter the password. Keep the remote control in a safe place at all times. Also, it's a good idea to write down your password.

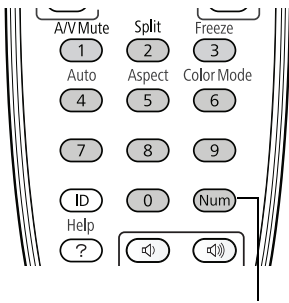

Hold down

4. Hold down the **Num** button on the remote control and use the numeric keypad to enter a four digit password. (The default setting is 0000.)
5. When you see a confirmation message, reenter the password. Then press the **Menu** button to exit the screen.

To set security options, access the Password Protect screen as described on page 121, and then turn on any of the following options:

- **Power On Protect** to prevent unauthorized use of the projector. After the projector is plugged in and turned on, you must enter a password to use the projector. For details, see “Starting the Projector with a Password” below.
- **User’s Logo Protect** to prevent your custom screen and display settings from being changed. None of the User’s Logo features in the Extended menu can be changed when the User’s Logo Protect function is enabled. For details on creating a custom screen, see page 123.
- **Network Protect** to lock the Network settings in the menu system.

Starting the Projector with a Password

When the password function is enabled, you see this screen when you plug in and turn on the projector:

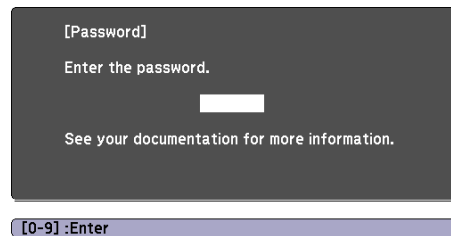

Hold down the **Num** button on the remote control and use the numeric keypad to enter the four digit password. The password screen closes and projection begins.

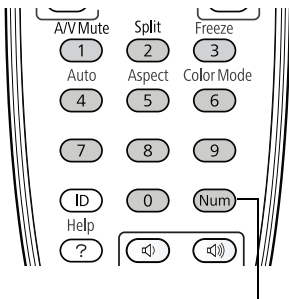

Hold down

If the password is not correct, you see a message prompting you to re-enter the password. If you enter an incorrect password three times in succession, you see the message **The projector's operation will be locked. Request code xxxxx.** Write down the request code. The message displays for approximately 5 minutes, and then the projector switches to standby mode. Once the projector is in standby mode, disconnect the projector's power cord from the electrical outlet, reconnect it, and turn the projector back on.

When you see the Password screen again, you can try to enter the correct password.

If you enter an incorrect password 30 times in succession, the projector remains locked and you must contact Epson to unlock it.

If you have forgotten the password, contact Epson with the request code number that appears in the Password screen for assistance. See "Where to Get Help" on page 161.

Creating Your Own Startup Screen

You can transfer any image from your computer or video source to the projector and then use it as your startup screen. You can also use it as the screen displayed when the projector is not receiving a signal or when you press the **A/V Mute** button. The image can be a company logo, slogan, photograph, or any other image you want to use.

Capturing the Image

Start by displaying the image you want to use from either a computer or video source, such as a DVD player or digital camera. Then follow these steps to capture the image and transfer it to the projector:

1. Press the **Menu** button, highlight the **Extended** menu, and press **Enter**.

note

When you choose an image for the user's logo, it erases any previously used image. You can save an image up to 400 × 300 pixels in size. Once you have saved a new user's logo, you cannot return to the factory default logo.

2. Highlight User's Logo and press Enter.

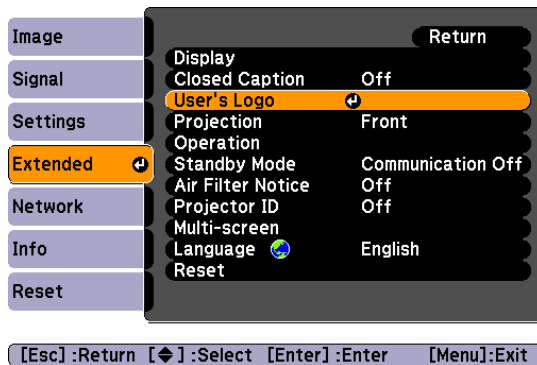

3. When you see a message asking Choose this image as the User's Logo?, select Yes and press Enter. A selection box displays over the image.
4. Use the  pointer button on the remote control (or the arrow buttons on the projector) to select the area of the image you want to use. Then press Enter.
5. When you see the message Select this image?, highlight Yes and press Enter.
6. Highlight a zoom factor (display size) and press Enter.
7. When the message Save this image as the User's Logo? appears, select Yes and press Enter. Saving the logo may take a few moments. Do not use your projector, remote control, or video source while the logo is being saved.
8. When you see the message Completed, press Menu to exit.

Choosing When to Display the Image

After your image is saved, you can set it to display as the startup screen, the screen you see when there's no signal, or the screen you see when you press the A/V Mute button (see page 67).

1. Press the Menu button, highlight the Extended menu, and press Enter.
2. Select Display and press Enter.

3. Choose from these display options:
 - Set **Display Background** to **Logo** to display your image when there is no signal.
 - Set **Startup Screen** to **On** to display your image when the projector is warming up.
 - Set **A/V Mute** to **Logo** to display your image when you press the **A/V Mute** button.
4. When you're finished, press **Menu** to exit.

note

You can lock these settings to prevent them from being changed without a password (see page 121).

Disabling the Projector's Buttons

When you enable the Control Panel Lock function, you can lock all of the projector's buttons, or all of the buttons except the **⏻** power button. The remote control can still be used to operate the projector.

1. Press the **Menu** button, highlight the **Settings** menu, and press **Enter**.
2. Select **Control Panel Lock** and press the **Enter** button.
3. Select **Full Lock** (to lock all projector buttons) or **Partial Lock** (to lock all buttons except the **Power** button) and press **Enter**.
4. Select **Yes** and press **Enter** to confirm the setting.
5. Press the **Menu** button to exit.

To disable the Control Panel Lock function, select **Off** in the Control Panel Lock menu. Or press and hold the **Enter** button on the projector's control panel for 7 seconds. A message is displayed and the lock is released.

Customizing Power and Operation

You can use the Extended menu to customize the way the projector displays images, enable quick startup, turn sleep mode on or off, and customize other projector operations.

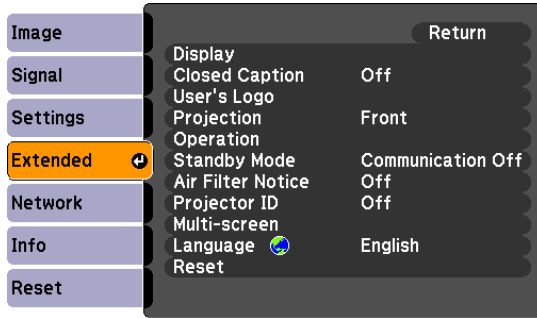

- **Display**
Use this setting to turn off the display of messages, change the background color, enable logo display, or turn off the startup screen display. With the PowerLite G5450WUNL/ G5750WUNL, you can also increase the size of the projector menus and messages.
- **Closed Caption**
Lets you display closed captioning for content that provides it.
- **User's Logo**
Create a custom startup screen, as described on page 123.
- **Projection**
Select **Front** (to project from the front of a screen and right side up), **Front/Ceiling** (when the projector is mounted upside-down from the ceiling), **Rear** (to project from behind onto a transparent screen), or **Rear/Ceiling** (to project from behind onto a transparent screen when the projector is mounted upside-down from the ceiling).
- **Operation**
Direct Power On: Enable if you want to be able to start the projector when you connect the power cord (without pressing the  power button).

note

If you hold down the **AN Mute** button on the remote control for about five seconds, you switch between **Front and Front/Ceiling** or **Rear and Rear/Ceiling**.

note

If **Direct Power On** is enabled, the power cord is connected, and a power outage occurs, the projector will start when the power is restored.

Sleep Mode: Enable if you want the projector to turn off automatically if it is idle and no signal is received for 1 to 30 minutes (you can adjust the amount of time using the next setting).

Sleep Mode Timer: When Sleep Mode is on, you can set the period of time before the projector turns off automatically, from 1 to 30 minutes.

High Altitude Mode: Enable when you are using the projector above 4,900 feet (1,500 meters) to ensure that the temperature is regulated properly. Turn this setting off for lower elevations.

BNC Sync Termination: Enable when analog (75Ω) termination (such as for switchers) is necessary.

Remote Control Type: Select **Normal** when you use the remote control provided with this projector, the PowerLite G5000, or the PowerLite Pro G5150NL, G5350NL, G5200WNL, Z8000WUNL, or Z8050WNL. Select **Simple** if you want to use the remote control provided with a different Epson projector.

Inv Direction Button: Enable when the projector is mounted on the ceiling to reverse the directions of the arrow buttons on the projector's control panel.

■ Standby Mode

Select **Communication On** to enable the projector to be monitored over a network when it is in standby mode (the power light is orange).

■ Air Filter Notice

Enable this option to receive a message on the screen when a clog in the air filter is detected.

■ Projector ID

Lets you assign a numeric ID to each projector. When you are using multiple projectors, you can use the ID to select the one you want to operate with the remote control. See page 71 for instructions.

note

Do not use the projector at altitudes above 9,800 feet (3,000 meters).

note

You cannot use this projector's remote control when the Remote Control Type is set to Simple. Select this setting carefully as changing it back may be difficult if the projector is mounted on the ceiling.

■ Multi-screen

Use this option if you want to color-match two or more projectors that are being used to display images near each other, or you are using the multi-screen feature to project from one source (one image) with multiple projectors (see the *EasyMP Network Projection Operation Guide*). You can make image adjustments at each of five adjustment levels. First choose an **Adjustment Level** and then adjust the settings for each level: **Brightness Correct** to adjust the brightness, and **Color Correct** to adjust the balance between red and green, or blue and yellow. See the next section for more information about multi-screen color adjustment.

■ Language

Select a language to use for the projector menus and messages.

Multi-screen Color Adjustment

You can match the color of projected images when two or more projectors are being used to display images near each other, or when you use the multi-screen feature to project from one source (one image) as described in the *EasyMP Network Projection Operation Guide*. For each screen, you can set five levels of brightness and color correction.

note

If you use two or more projectors side-by-side, exhaust from adjacent projectors might cause overheating. Leave at least 2 feet (60 centimeters) of space between projectors.

1. Before starting, you may want to assign a numeric ID to each projector. This lets you use the remote control to select the projector you want to adjust. See page 71 for instructions.

To match the display colors as closely as possible, make sure that all the projectors are set to the same color mode before starting. See page 114 for instructions.

2. Press the **Menu** button, highlight the **Extended** menu, and press **Enter**.
3. Select **Multi-screen** and press **Enter**.
4. Start by setting the **Adjustment Level** to 1 for two projectors. Then use **Brightness Correct** to match the darker projector to the lighter one. Press **Enter** to see the effects of your adjustments.

5. Next, adjust the brightness of Level 5 for the same two projectors. Match the brighter projector to the darker one.
6. Adjust and match the brightness of Levels 2, 3, and 4.
7. Adjust and match the G/R color correction for all levels. Then adjust and match the B/Y correction for all levels.
8. If you are using three or more projectors, repeat steps 4 through 7 to match projector 3 to projector 2, then match projector 4 to projector 3, and so on.

Projector Menu and Options List

The table below shows the options you can select based on the projector menu you are viewing. Some options may not be available depending on the projector model and input source you are using.

For more information on these menus and options, read this chapter.

Menu	Options
Image	Color Mode Brightness Contrast Color Saturation Tint Sharpness Abs. Color Temp. Color Adjustment Reset

Menu	Options
Signal	Auto Setup Resolution Tracking Sync. Position Progressive Noise Reduction HDMI Video Range DVI/HDMI Video Range Input Signal Video Signal Aspect Overscan 2-2 Pull-down Reset
Settings	Keystone Split Screen Control Panel Lock Pointer Shape Power Consumption Volume Audio Input Remote Receiver User Button Test Pattern Reset
Extended	Display Closed Caption User's Logo Projection Operation Standby Mode Air Filter Notice Projector ID Multi-screen Language Reset
Network	Basic Wireless LAN Security Wired LAN Mail Others Reset

Menu	Options
Info	Lamp Hours Source Input Signal Resolution Video Signal Refresh Rate Sync Info Status Serial Number Event ID
Reset	Reset All Reset Lamp Hours

6

Maintaining the Projector

Your projector needs little maintenance. All you have to do is keep the lens clean. You may also need to clean the air filter and vent. A clogged air filter or vent can block ventilation needed to cool the projector.

warning

Before you clean any part of the projector, turn it off and unplug the power cord.

Never open any cover on the projector, except the lamp cover. Dangerous electrical voltages in the projector can injure you severely. Do not try to service this product yourself, except as specifically explained in this User's Guide. Refer all other servicing to qualified service personnel.

The only parts you should replace are the lamp and air filter. If any other part needs replacing, contact your dealer or a qualified servicer.

This chapter covers the following:

- Cleaning the lens
- Cleaning the projector case
- Cleaning the air filter
- Replacing the air filter
- Replacing the lamp
- Replacing the remote control batteries
- Transporting the projector

caution

Do not rub the lens with harsh materials or subject the lens to shocks, as it can easily become damaged.

caution

Do not use wax, alcohol, benzene, paint thinner, or other chemical detergents. These can damage the case.

note

To order replacement air filters, request part number V13H134A17. See page 15 for ordering information.

Cleaning the Lens

Clean the lens whenever you notice dirt or dust on the surface.

To remove dirt or smears on the lens, use a commercially available cloth for cleaning glasses.

Cleaning the Projector Case

Before you clean the case, turn off the projector and unplug the power cord.

- To remove dirt or dust, wipe the case with a soft, dry, lint-free cloth.
- To remove stubborn dirt or stains, moisten a soft cloth with water and a neutral detergent and firmly wring the cloth dry. Then wipe the case.

Cleaning the Air Filter

Your projector includes an air filter to ensure the best performance. If dust collects on the air filter (on the side of the projector), you see a message on the screen telling you to clean the filter, or the  Temp light flashes green, clean the filter as described on page 135. Dust clogs prevent proper ventilation and can cause overheating, which can damage the projector.

Follow these steps:

1. Press the  power button on the back of the projector to turn it off. After the projector beeps twice, unplug the power cord.
2. Grip the air filter cover tab and remove the air filter cover as shown.

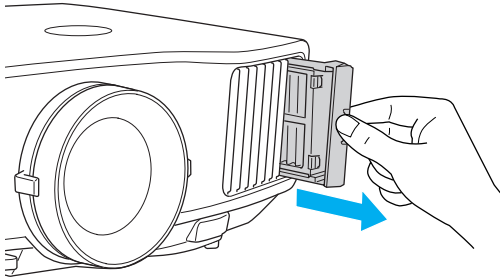

3. Place your finger into the groove and remove the air filter as shown.

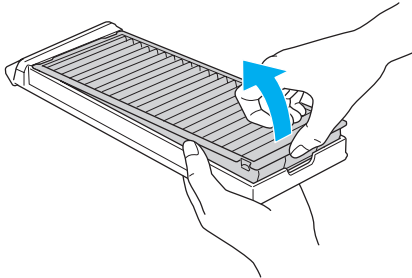

4. With the front of the air filter facing down, tap it four or five times to shake off the dust. Turn it over and tap the other side in the same way to shake off the dust.

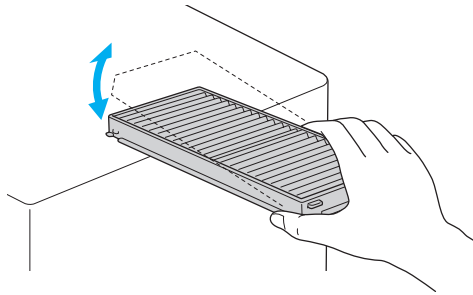

5. To clean any dust remaining on the air filter, use a small vacuum cleaner designed for computer and other office equipment to clean the front. If you don't have one, gently clean the vent with a soft brush (such as an artist's paintbrush).

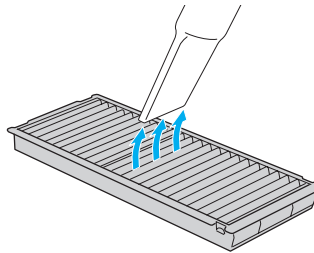

6. Insert the air filter back into the holes in the cover, then press it firmly into place.

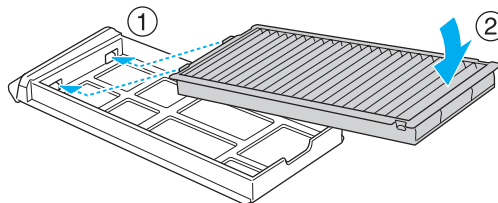

7. Slide the air filter cover in until it clicks into place.

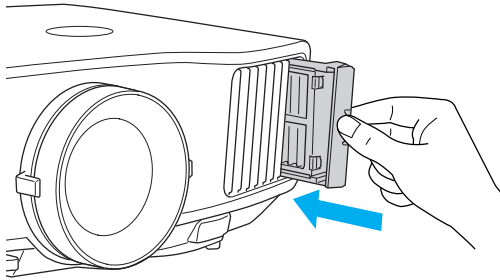

8. If the dirt is difficult to remove, the filter is broken or discolored, or you continue to see air filter related messages even after cleaning, replace the filter as described in the next section. Contact your dealer or call Epson at 800-GO-EPSON (800-463-7766) to obtain a new filter.

Replacing the Air Filter

Follow these steps to replace the air filter:

1. Press the  power button on the back of the projector to turn it off. After the projector beeps twice, unplug the power cord.
2. Grip the air filter cover tab and remove the air filter cover as shown.

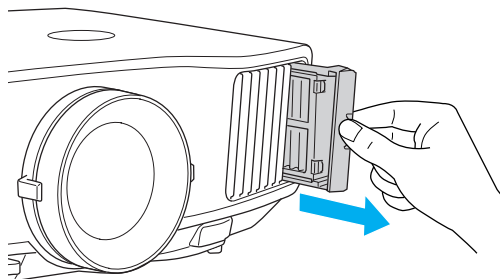

note

The air filter contains Polypropylene. Dispose of used air filters properly in accordance with your local regulations.

3. Place your finger into the groove and remove the air filter as shown.

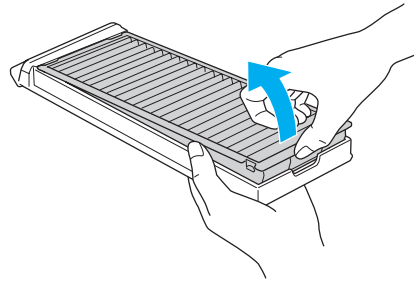

4. Insert the new air filter into the holes in the cover, then press it firmly into place.

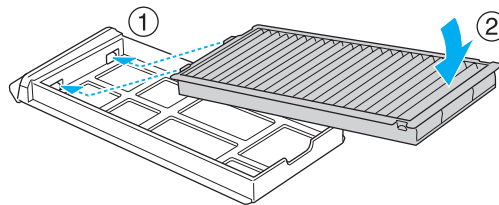

5. Slide the air filter cover in until it clicks into place.

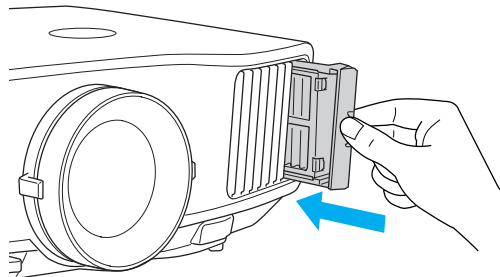

note

Turn off this product when not in use to prolong the life of the projector.

Do not turn the projector on immediately after turning it off. Turning the projector on and off frequently may shorten the life of the lamp.

Replacing the Lamp

The life span of the projection lamp is about 2000 hours if **Power Consumption** in the Settings menu is set to **Normal** (default), and 3000 hours if **Power Consumption** is set to **ECO**.

See page 142 to check the lamp usage.

It is time to replace the lamp when:

- The projected image gets darker or starts to deteriorate.
- The message **Replace the lamp** appears on the screen when the lamp comes on.
- The  Lamp light flashes orange.

To maintain projector brightness and image quality, replace the lamp as soon as possible.

You may also need to replace the lamp if the  Lamp light flashes red. See page 147.

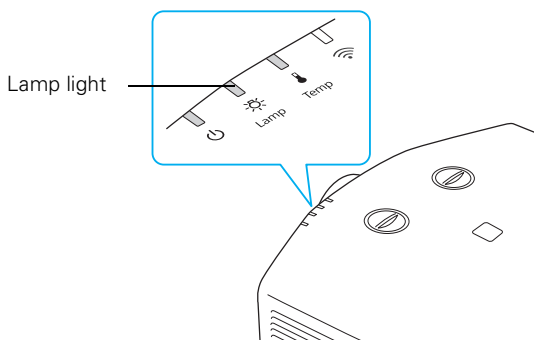

Contact your dealer or call Epson at 800-GO-EPSON (800-463-7766). Request part number V13H010L62 (G5450WUNL/G5550NL) or V13H010L63 (G5650WNL/G5750WUNL/G5950NL).

Follow these steps to replace the lamp:

1. Press the  power button on the back of the projector to turn it off. After the projector beeps twice, unplug the power cord.
2. Let the projector cool for at least an hour (if it has been on). The lamp is extremely hot immediately after use.

note

Epson recommends that you clean the air filter whenever you replace the lamp.

warning

Let the lamp cool fully before replacing it.

In the unlikely event that the lamp has broken, small glass fragments may be present and should be removed carefully to avoid injury. If the projector has been installed on the ceiling, you should stand to the side of the lamp cover, not underneath it.

If the lamp is used after the replacement period has passed, the possibility that the lamp may break increases. When a lamp replacement message appears, replace the lamp with a new one as soon as possible, even if it is still working.

note

Even when the lamp cover is removed, it is still attached to the projector to prevent it from falling when the projector is mounted on the ceiling.

3. Loosen the lamp cover screws (you don't need to remove them). Then remove the lamp cover.

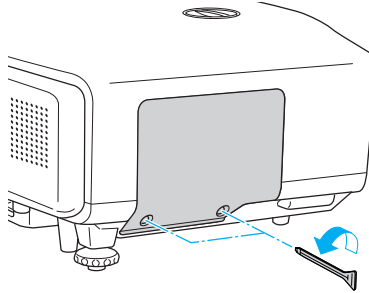

4. Loosen the two screws holding the lamp in place (you can't remove them).

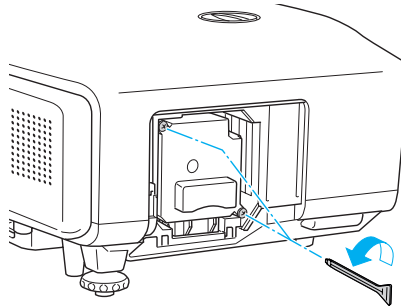

Loosen, but don't remove these screws

5. Hold the lamp as shown and pull it straight out.

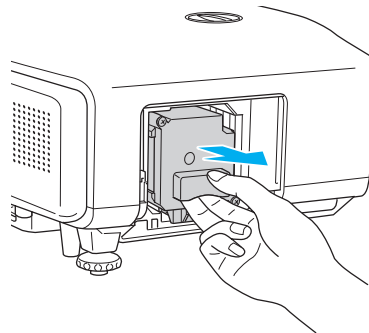

6. Gently insert the new lamp. (If it doesn't fit easily, make sure it is facing the right way.)

note

 The lamp(s) in this product contain mercury. Please consult your state and local regulations regarding disposal or recycling. Do not put in the trash.

- Once the lamp is fully inserted, tighten its screws.

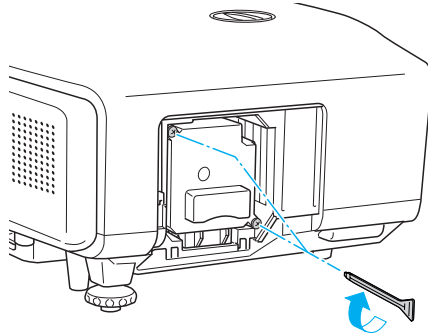

- Replace the lamp cover, then tighten its screws.
- Reset the lamp timer as described in the next section.

Resetting the Lamp Timer

After you replace the lamp, you need to reset the lamp timer using the projector's menu.

- Press the **Menu** button on the remote control or on the projector's control panel. You see the main menu.
- Use the  pointer button on the remote control (or the arrow buttons on the projector) to highlight **Reset**, then press **Enter**.

You see this screen:

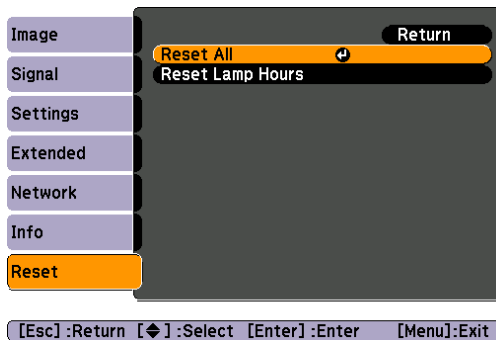

- Select **Reset Lamp Hours** and press **Enter**.
- When you see the prompt, select **Yes** and press **Enter**.

- When you're finished, press **Menu** to exit.

Checking Lamp Usage

To check the number of hours the lamp has been used, press the **Menu** button and highlight the **Info** menu. You see a screen like this:

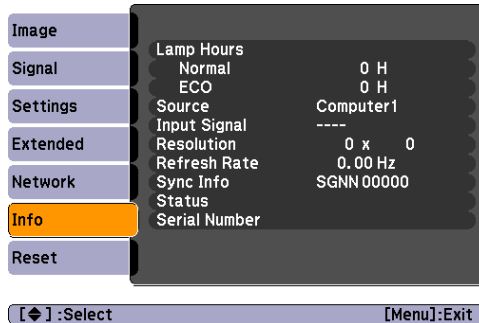

The life span of the projection lamp is about 2000 hours if **Power Consumption** in the **Settings** menu is set to **Normal** (default), and 3000 hours if **Power Consumption** is set to **ECO**. Make sure you have a spare lamp handy if the usage hours on this menu are close to the life span of your lamp.

Replacing the Batteries

Replace the batteries in the remote control as described below:

- Turn the remote control over.
- Push the tab on the battery cover as you lift the cover off.

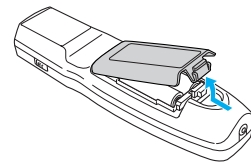

note

The information displayed depends on the input signal currently selected.

caution

When replacing batteries, take the following precautions:

- *Replace the batteries as soon as they run out. If the batteries leak, wipe away battery fluid with a soft cloth. If fluid gets on your hands, wash immediately.*
- *Do not expose batteries to heat or flame and do not put them in water.*
- *Dispose of used batteries according to local regulations.*
- *Do not use batteries other than those specified in this User's Guide and do not use batteries of different types or mix old and new batteries.*
- *Keep these batteries out of the reach of children. Batteries are choking hazards and are very dangerous if swallowed.*

3. Install two AA alkaline batteries, inserting the + and – ends as shown.

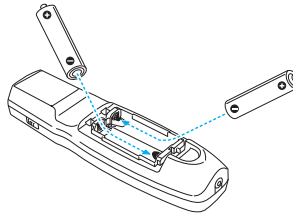

4. Position the cover as shown, then press down until it snaps into place.

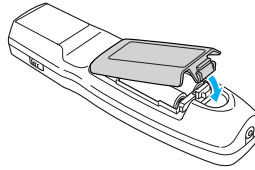

Transporting the Projector

The projector contains many glass and precision parts. Follow these guidelines to prevent damage:

- If you are moving the projector by hand, use the projector handle.
- Attach the lens cover to the lens.
- Return the projector feet to their stored (highest) positions.

Additionally, follow these guidelines when you are transporting the projector a long distance:

- Turn the vertical lens shift dial so that the lens is in its lowest position.
- When packing the projector, use the original packaging material if possible, including the protective lens pads. If you do not have the original packaging, use equivalent materials, placing plenty of cushioning around the projector to protect it from shock.

note

Epson shall not be liable for any damages incurred during transportation.

7

Solving Problems

This chapter helps you solve problems with your projector, and tells you how to contact technical support for problems you can't solve yourself. The following information is included:

- Using the projector's on-screen help system
- What to do when the projector's status lights flash
- Solving projector operation problems
- Solving problems with the image or sound
- Solving network problems
- Solving problems with the remote control
- Contacting technical support

Using On-Screen Help

If the image doesn't look right or your audio isn't working, you can get help by pressing the ? Help button on the back of the projector or on the remote control.

1. Press the ? Help button on the remote control or on the projector.

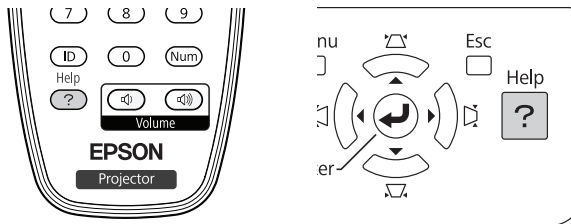

You see the Help menu:

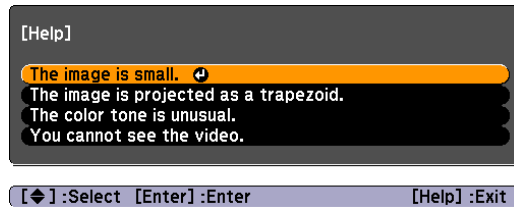

2. Use the  pointer button on the remote control or the navigational buttons on the projector to highlight menu items.
3. Press the **Enter** button on the remote control or on the projector to select the menu item.
4. To exit the help system, press the ? Help button.

If none of the suggestions solve your problem, see additional solutions to problems in the following sections.

Checking Projector Status

If your projector isn't working correctly, first turn it off and unplug it. Then plug the power cord back in and turn on the projector. If this doesn't solve the problem, check the lights on top of the projector.



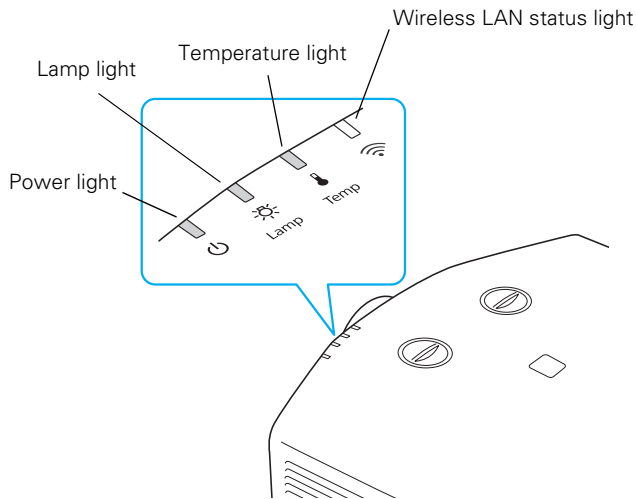

What To Do When the Lights Flash

The lights on top of the projector indicate the projector's status.













Refer to the following table for a complete description of the projector's status lights:



Status lights

Light	Status	Description
	Orange	The projector is in sleep or standby mode. You can unplug it or press the  power button to turn it on.
	Flashing green	The projector is warming up. Wait for the image to appear.
	Green	The projector is operating normally.

Status lights (continued)



Light	Status	Description
	Flashing orange	The projector is cooling down. You can't turn it back on (and you should not unplug it) until the light stops flashing and remains orange. The projector is setting itself up for network monitoring.
	Flashing green	The air filter may be clogged. Clean or replace the air filter as described on pages 134 to 138.
	Red or flashing red	There is a problem with the projector. Check the other two lights and the information on page 149 to diagnose the problem.
	Flashing orange	It's time to replace the lamp. See page 138 for instructions. If you continue to use the lamp after the replacement warning, there is an increased possibility that the lamp may break.
	Flashing orange	Rapid cooling is in progress. Although this is not an abnormal condition, projection will stop automatically if the temperature rises higher. Make sure there is plenty of space around and under the projector for ventilation, and that the vents are clear. The air filter may be clogged. Clean or replace the air filter as described on pages 134 to 138.
	Red	The projector is overheating, which turns the lamp off automatically. Wait until the projector switches to standby mode (about 5 minutes). Make sure the room temperature is not outside the required temperature range of the projector (see page 173), and there is plenty of space around and under the projector for ventilation. The air filter may be clogged. Clean or replace the air filter as described on pages 134 to 138. If you're using the projector above an altitude of 4,900 feet (1,500 meters), turn on High Altitude Mode in the Operation menu (see page 126). If the projector continues to overheat after you clean the air filter, the problem may be caused by damage to the cooling fan or temperature sensor. Contact Epson for help as described on page 161. Warning: Except as specifically explained in this <i>User's Guide</i> , do not attempt to service this product yourself.
 	Flashing red	Power is cut off because of an internal problem. Unplug the power cord and contact Epson for help, as described on page 161.
  	Flashing red	

Status lights (continued)

Light	Status	Description
	Flashing red	There is a problem with the fan or temperature sensor. Stop using the projector, disconnect the power cord, and contact Epson as described on page 161.
	Flashing red	<p>The lamp may be burnt out. First make sure the lamp cover is securely installed. If that's not the problem, the air filter may be clogged. Clean or replace the air filter as described on pages 134 to 138.</p> <p>If this does not resolve the problem, let the lamp cool and then remove it. If the lamp is cracked, replace it as described on page 138. If the lamp is not cracked, reinstall it. If reinstalling doesn't work, replace the lamp.</p> <p>If you're using the projector above an altitude of 4,900 feet (1,500 meters), turn on High Altitude Mode in the Operation menu (see page 126).</p> <p>If none of these suggestions resolves the problem, contact Epson as described on page 161.</p>

Solving Projector Operation Problems

The power doesn't turn on.

- If the projector doesn't turn on when you press the  power button, make sure the power cord is connected to the projector and plugged into a working electrical outlet.
- The power cord may be defective. Disconnect the cord from the outlet and contact Epson as described on page 161.
- If you're using the Direct Power On function and you immediately plug the power cord back in after unplugging it, the power may not turn back on. Press the  power button to turn the projector back on.

The buttons on the projector don't work.

If the Control Panel Lock function has been enabled, you can't use the buttons on the projector. Try using the remote control instead (make sure it is set to the correct ID). See page 125 for information about the Control Panel Lock function.

Solving Problems With the Image or Sound

No image appears on the screen.

- Check that the ⏻ power light is green, not flashing, and that the lens cover is removed.
- The projector may be in standby or sleep mode. If the ⏻ power light is orange, press the ⏻ power button to turn the projector on.
- If the power was switched off and then on again, the projector may be cooling down. Wait until the ⏻ power light stops flashing and remains orange; then press the ⏻ power button again.
- Press the **A/V Mute** button on the remote control to make sure the picture has not been turned off temporarily.
- The attached computer may be in sleep mode or displaying a black screen saver. Try pressing a key on the computer.
- If you are projecting from a DVD player or other video source, make sure you turn it on and press its **Play** button.
- If you are projecting from a video source, make sure the Video Signal setting is correct (see page 116).
- You can also try resetting all of the configuration menu settings. See page 113.

You've connected a computer and see a blue screen with the message No Signal displayed.

- Make sure the cables are connected correctly, as described beginning on page 30.

- If you've connected more than one computer and/or video source, you may need to press the **Source Search** button on the projector's control panel, or the **Search** button or one of the **Source** buttons on the remote control to select the correct source. (Allow a few seconds for the projector to sync up after pressing the button.)
- Make sure the power for your connected equipment is turned on.

If you're using a PC notebook:

- Press the function key on your keyboard that lets you display on an external monitor. It may be labeled **CRT/LCD** or have an icon such as . You may have to hold down the **Fn** key while pressing it. Allow a few seconds for the projector to sync up after changing the setting. Check your notebook's manual or online help for details.

On most systems, the  key lets you toggle between the LCD screen and the projector, or display on both at the same time.

If you connect the notebook while the projector or computer are already turned on, the function key that changes the computer's image signal to external output may not work. Turn the computer and the projector off and then back on again.

- Depending on your computer's video card, you might need to use the Display utility in the Control Panel to make sure that both the LCD screen and external monitor port are enabled. See your computer's documentation or online help for details.

If you're using Mac OS X:

1. Open System Preferences.
2. Click Displays.
3. Click Detect Displays.
4. Do one of the following:

Mac OS X 10.6.x users: Click Show displays in menu bar.

Other Mac OS X users: Make sure the VGA Display or Color LCD dialog box is selected, click the Arrangement or Arrange tab, then make sure the **Mirror Displays** checkbox is selected.

The message Not Supported is displayed.

- Make sure the correct input signal is selected in the Signal menu (see page 116).
- Make sure your computer's resolution and frequency or refresh rate is supported by the projector (see page 174). If necessary, change your computer's settings.

The projector and notebook don't display the same image

If you're using a PC notebook:

- On most systems, there's a function key that lets you toggle between the LCD screen and the projector, or display on both at the same time. It may be labeled CRT/LCD or have an icon such as . You may have to hold down the Fn key while pressing it. Allow a few seconds for the projector to sync up after changing the setting.
- If the function key doesn't permit you to display simultaneously on both screens, you should check your monitor settings to make sure both the LCD screen and the external monitor port are enabled.

From the Control Panel, open the **Display** utility, select the **Settings** option, then select the **Advanced** option (in Windows Vista, right-click on the desktop, select **Personalize**, select **Display Settings**, then select **Advanced Settings**). The method for adjusting the settings varies by brand; you may need to click a **Monitor** tab, then make sure the external Monitor port is set as your primary display and/or enabled. See your computer's documentation or online help for details

If you're using Mac OS X:

You may need to set up your system to display on the projector screen as well as the LCD screen. Make sure your projector is connected, then follow these steps:

1. Open **System Preferences**.
2. Click **Displays**.

3. Click **Detect Displays**.
4. Do one of the following:

Mac OS X 10.6.x users: Click **Show displays** in menu bar.

Other Mac OS X users: Make sure the **VGA Display** or **Color LCD** dialog box is selected, click the **Arrangement** or **Arrange** tab, then make sure the **Mirror Displays** checkbox is selected.

Only part of the computer image is displayed.

- Press the **Auto** button on the remote control or the **Enter** button on the projector.
- Make sure the image **Position** setting is correct in the **Signal** menu. See page 117 for more information.
- Press the **Aspect** button on the remote control.
- Press the **Esc** button on the remote control to cancel the **E-Zoom** function.
- Make sure your computer's resolution setting is correct. See the compatible video formats listed on page 174.
- You also may need to modify existing presentation files if you created them for a different resolution. See your software documentation for specific information.
- If you're projecting a wide panel computer image, adjust the **Resolution** setting (see page 116).
- If you're projecting an image from a computer with dual display activated, turn dual display off.

The image isn't square, but keystone-shaped.

If the image isn't square or rectangular, adjust its shape as described on page 58.

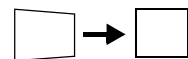
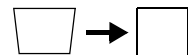

The image contains static or noise.

- Make sure the cables are securely connected.

- If you're using a computer cable longer than 6 feet (1.8 meters), or an extension cable, the image quality may be reduced.
- Keep your computer and video cables away from the power cord as much as possible to prevent interference.
- The video signal may be split between the computer and the projector. If you notice a decline in the projected image quality when the image is displayed simultaneously on your notebook computer and the projector, turn off the notebook's LCD display.
- Make sure the correct input signal is selected in the Signal menu (see page 118).
- If you've used the Quick Corner or Keystone adjustment, you may need to decrease the **Sharpness** setting in the Image menu (see page 115).
- If you're projecting from a computer, make sure its signal is compatible with the projector. See page 174.
- If you're using the Split Screen function, you may need to set the Resolution setting in the Signal menu to **Auto** (see page 117).
- Press the **Auto** button on the remote control or the **Enter** button on the projector to reset the projector's Tracking, Sync, and Position settings. If further adjustment is needed, you can fine-tune the Tracking and Sync settings manually using the Signal menu, as described on page 117.

note

*You must be projecting an image for the **Auto** button to have any effect. It works only with computer images projected through the VGA port.*

The image is blurry.

- There may be dirt or smears on the lens. Clean the lens as described on page 134.
- Adjust the focus using the focus ring (see page 58).
- If the projector is angled sharply toward the screen, it may not be possible to focus the entire image. Move the projector to position it more directly in front of the screen.
- Lower the projection angle to reduce the amount of keystone correction required.

- Make sure the projector is within the proper range (projection distance) from the screen (see page 170).
- Make sure the lens is not fogged by condensation. You may need to wait before using the projector after moving it from a cold environment to a warm environment.
- If you're projecting from a computer, you may need to adjust the tracking and sync settings as described in the next section.

You see vertical bands or the image still looks blurry after trying the solutions in the previous section.

- If you're projecting from a computer and displaying an image that contains a lot of fine detail, you may notice vertical bands or some of the characters may look heavy or blurred. Press the **Auto** button on the remote control or the **Enter** button on the projector to reset the projector's Tracking, Sync, and Position settings.
- If further adjustment is needed, you can fine-tune the **Tracking** and **Sync** settings manually using the Signal menu, as described on page 117.
 1. Fill the screen with an image containing fine detail, such as a pattern to appear as your desktop background, or try projecting black text on a white background.
 2. Adjust the **Tracking** to eliminate vertical bands.

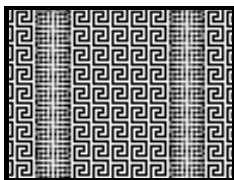

3. Adjust the **Sync** setting to increase the image sharpness.

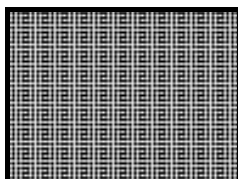

note

*You must be projecting an image for the **Auto** button to have any effect. It works only with computer images projected through the VGA port.*

note



Because of the different technologies used, your projected image may not exactly match the colors on your notebook or computer monitor.

The image is too light or dark, or colors are incorrect.

- Use the **Color Mode** option in the projector's Image menu to adjust the color (see page 114).
- If you're displaying video, adjust the **Color Adjustment** and **Color Mode** settings on the Image menu. You can also try adjusting the **Color Saturation**, **ABS Color Temp**, and **Tint** settings on the Image menu.
- Try adjusting the **Brightness** and **Contrast** settings on the Image menu.
- Try adjusting the **Power Consumption** setting (see page 119).
- Check your computer display settings to correct the color balance.
- The projector's lamp may need to be replaced. See page 138 for instructions.
- Make sure the correct input signal is selected in the **Signal** menu (see page 118).
- Make sure that all cables are connected to the proper ports and connected securely.

There is no sound, or the sound is not loud enough.

- Use the **Volume** buttons on the remote control to adjust the volume, or adjust the **Volume** setting in the **Settings** menu (see page 120).
- Make sure **A/V Mute** is not enabled. (The **A/V Mute** button may have been pressed.)
- If your presentation includes computer audio, make sure the volume control on your computer is not turned all the way down or muted. In Windows, you may be able to check this by clicking the volume control in your Windows system tray (lower right corner of the screen). On a Mac, you may be able to adjust the volume from your menu bar (top right corner of the screen) or via the volume control function keys.
- If you're using a DVD player or other video source, make sure the cables are connected correctly, as described on page 46.

- If you're using a computer audio cable, make sure it is connected to your computer's  headphone jack or  audio out jack. Connect the other end to the projector as described on page 46.
- If you're using an HDMI cable and you hear no sound, set your equipment to PCM output.
- If your equipment is connected through the LAN port, or the HDMI port with the PowerLite G5550NL/G5650WNL/G5950NL, make sure you've set the **Audio Input** setting correctly. See page 119.

Nothing Appears on an External Monitor

- The only images that can be displayed on an external monitor are computer images connected through the **Computer1**, **Computer2** (G5550NL/G5650WNL/G5950NL only) or **BNC** input ports. See page 45.
- If you are using the Split Screen function, the computer image must be on the left side if you want to display it on an external monitor. See page 62.

Solving Network Problems

The projector does not send e-mail alerts even though the e-mail notification function has been turned on.

- Make sure the mail notification function is set correctly in the configuration menu. See page 98.
- Set Standby Mode to **Communication On** in the Extended menu. Otherwise, the projector cannot send e-mails when it is in Standby mode (when the power is off).
- If a critical problem develops with a projector which causes it to suddenly stop working, it may not be possible for the projector to send a message.

- Make sure the projector is plugged in.
- Make sure the LAN cable is connected correctly. Reconnect it if it is not connected or it is not connected correctly (see page 76).

For problems with the EasyMP Network Projection software, see the *EasyMP Network Projection Operation Guide*.

For problems with the EasyMP Multi PC Projection software, see the *EasyMP Multi PC Projection Operation Guide*.

For problems with EasyMP Monitor (available for Windows only), see the *EasyMP Monitor Operation Guide*.

You can also check the Event ID in the projector when you have network related problems:

1. Press the **Menu** button and highlight the **Info** menu.
2. If you see an **Event ID** at the bottom of the menu, refer to the following table for additional information:

Event ID	Description
0432 0435	EasyMP Network Projection failed to start. Turn the projector off and then back on.
0434 0481 0482 0485	Network communication is unstable. Check the status of your network. Wait a few moments, then try connecting to the projector again.
433	A transferred image cannot be projected. Restart EasyMP Network Projection.
484	There was a network communication problem. Restart EasyMP Network Projection.
04FE	Check the status of your network. Turn the projector off and then back on.
0891	There is a an SSID problem. Set the computer, access point, and projector to the same SSID.
0892	There is a problem related to WPA or WPA2 authentication. Check the setting wireless LAN security setting in the projector (page 93).

Event ID	Description
0893	There is a problem related to WEP, TKIP, or AES encoding. Check the setting wireless LAN security setting in the projector (page 93).
0894	There was a network communication problem because a connection was made to the wrong access point. Consult your network administrator.
0898	Failed to obtain DHCP settings. Check the DHCP server to make sure it is operating correctly. Turn off DHCP in the projector if it is not being used. See page 76 (for a wired connection) or page 81 (for a wireless connection).
0899	Connection error. If you cannot resolve the problem by restarting EasyMP Network Projection or turning the projector off and on, contact Epson for help as described on page 161.

Solving Problems With the Remote Control

The projector doesn't respond to remote control commands.

- Point the remote control towards the receiver.
- Make sure the projector and remote control IDs match. To operate all projectors by remote control regardless of ID settings, set the ID switch on the side of the remote control to **Off**.
- The remote control's batteries may not be installed correctly or may be low on power. To change the batteries, see page 142.
- Make sure you are within about 49 feet (15 meters) of the projector and within range of the projector's front or back sensor.
- Dim the room lights and turn off any fluorescent lights. Make sure the projector is not in direct sunlight. Strong lighting, especially fluorescent lights, may affect the projector's infrared receivers. Also, turn off any nearby equipment that emits infrared energy, such as a radiant room heater. If necessary, use the **Remote Receiver** setting to disable the projector's front or back sensor if it continues to pick up interference (see page 120).
- Make sure the **Remote Receiver** setting isn't disabling both of the projector's sensors (see page 120).
- If any buttons are held for longer than 30 seconds, the remote enters sleep mode. Release any button that is held to wake the remote.
- When the optional remote control cable is connected, the remote control light-emitting area and the projector's remote receiver are disabled. If you're not using the cable, make sure it is disconnected from both the remote control and the projector.
- Make sure the **Remote Control Type** setting is correct. See page 126.

Where to Get Help

Epson provides these technical support services:

Internet Support

Visit Epson's support website at www.epson.com/support for solutions to common problems. You can download utilities and documentation, get FAQs and troubleshooting advice, or e-mail Epson with your questions.

Speak to a Support Representative

To use the Epson PrivateLine Support service, call (800) 637-7661 and enter the PIN on the included Epson PrivateLine Support card. This is the fastest way of speaking to a live representative, and it's free. This service is available 6 AM to 6 PM, Pacific Time, Monday through Friday, for the duration of your warranty period.

You may also speak with a projector support specialist by dialing one of these numbers:

- U.S.: (562) 276-4394, 6 AM to 6 PM, Pacific Time, Monday through Friday.
- Canada: (905) 709-3839, 6 AM to 6 PM, Pacific Time, Monday through Friday.

Days and hours of support are subject to change without notice. Toll or long distance charges may apply.

Before you call for support, please have the following information ready:

- Product name (PowerLite Pro G5450WUNL, G5550NL, G5650WNL, G5750WUNL, or G5950NL)
- Product serial number (located both on the projector and in the projector's menu as described on page 162)
- Proof of purchase (such as a store receipt) and date of purchase
- Computer or video configuration

- Description of the problem

You can obtain the serial number from the projector's menu system: Just press the **Menu** button and highlight the **Info** menu.

Purchase Supplies and Accessories

You can purchase screens and other accessories from an Epson authorized reseller. To find the nearest reseller, call 800-GO-EPSON (800-463-7766). Or you can purchase online at www.epsonstore.com (U.S. sales) or www.epson.ca (Canadian sales).

A *Projector Installation*

This appendix provides guidelines on installing the projector in a permanent location, such as a theater or conference room.

Installation Guidelines

The projector can be installed for four different viewing setups: front projection, ceiling projection, rear projection onto a semi-transparent screen, or rear/ceiling projection, as shown:

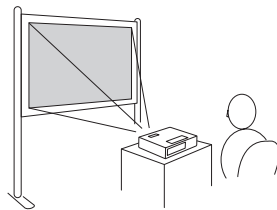

Front projection

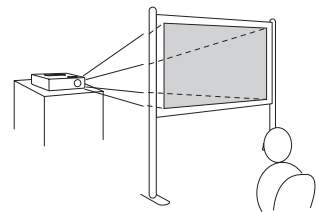

Rear projection

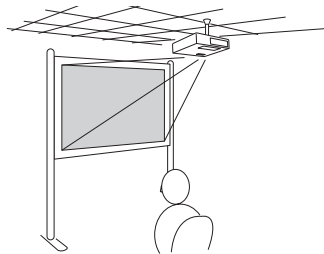

Ceiling projection

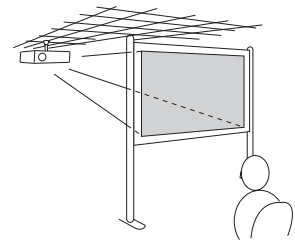

Rear/ceiling projection

To project from overhead, you'll need the optional ceiling mounting hardware (see page 15). You'll also need to select the appropriate **Projection** setting in the projector's Extended menu to flip the image upside-down (see page 126).

If you're mounting the projector on the ceiling and you place it above screen level, you'll have to tilt the projector down to position the image on the screen. This causes the image to lose its square shape. You can correct the image using the projector's **Quick Corner** and/or **Keystone** functions, as described on page 58.

Security Features

The projector includes security features to prevent its theft when installed or used in public locations:

- **Security cable attachment.** You can attach a commercially available security cable as shown below to secure the projector to a table or ceiling mount.

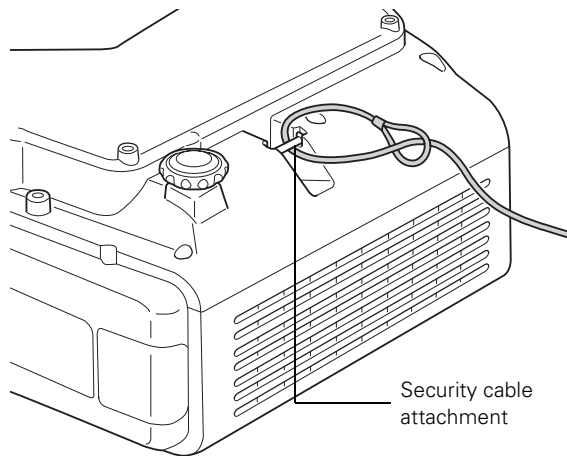

- **Kensington security slot.** The security slot (located above the power inlet) is compatible with the MicroSaver security systems manufactured by Kensington. You can purchase this lock from Epson (see page 15).

- **Lens theft deterrent screw.** You can lock the lens with the supplied screw, so that the lens cannot be removed.

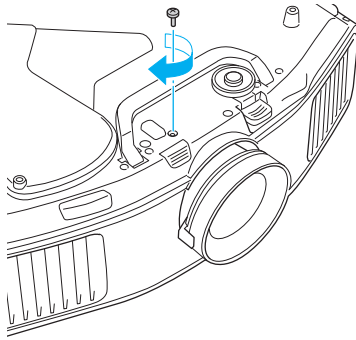

In addition, the projector includes several menu-operated security features. See page 121.

Installing and Removing the Cable Cover

Install the rear cable cover to enhance the appearance of the projector and prevent any cables from being loosened or removed. To install the cover, follow these steps:

1. Insert its tabs into the slots as shown, then push the cover against the projector.

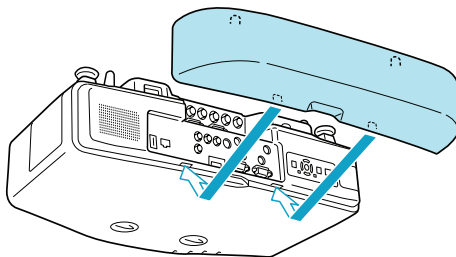

note

These illustrations show the projector mounted on the ceiling.

2. Tighten the screws at the bottom of the cover.

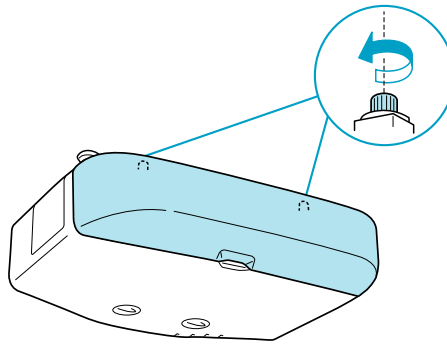

3. To remove the cover (when connecting or disconnecting cables), loosen the screws on the bottom of the cover, pull the bottom of the cover away from the projector as shown.

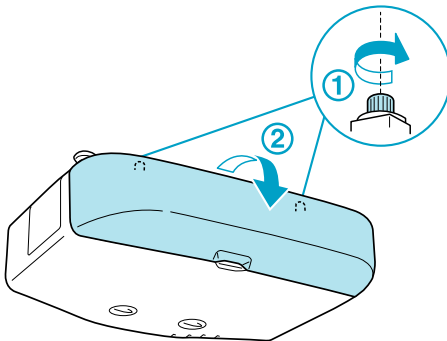

Installing and Removing the Lens

See the following sections for instructions on installing and removing the lens.

Installing the Lens

1. Turn off the projector and unplug the power cord.

2. Turn the focus ring clockwise until it stops moving.

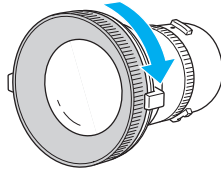

3. Make sure the white dot on the lens is facing up. Insert the lens straight into the projector, then turn clockwise until you hear it click into place.

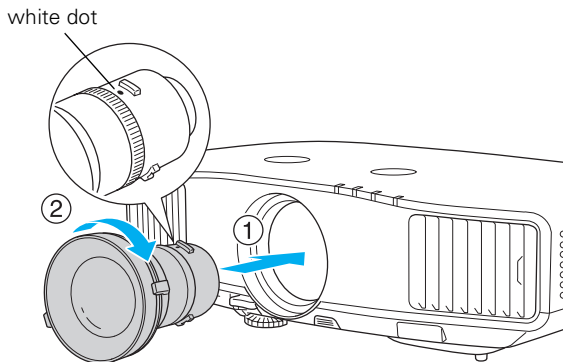

4. If necessary, attach the lens theft deterrent screw (see page 165).

Removing the Lens

1. Turn off the projector and unplug the power cord.
2. If you've attached the lens theft deterrent screw, remove it (see page 165).

note

Only install or remove the lens when necessary. If dust enters the projector, projection quality may deteriorate and/or the projector may malfunction.

Do not install or remove the lens when the projector's lens insertion section is facing up. Dust could enter the projector.

Do not touch the lens with your hand or fingers. If fingerprints or oils are left on the surface of the lens, projection quality will deteriorate.

note

If you have moved the lens with the lens shift dials (see page 57), center the lens again before removing it.

3. Hold down the lens removal button and turn the lens counterclockwise until you hear it click.

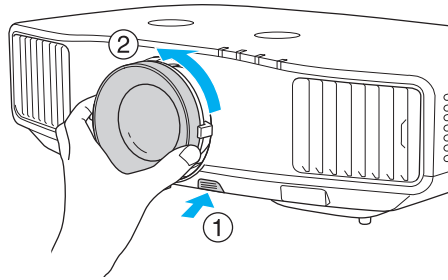

4. Remove the lens by pulling it straight out.

B *Technical Specifications*

General

Type of display	Epson poly-silicon TFT active matrix
Resolution (native format)	PowerLite Pro G5550NL/G5950NL: 1024 × 768 pixels (XGA) PowerLite Pro G5650WNL: 1280 × 800 pixels (WXGA) PowerLite Pro G5450WUNL/G5750WUNL: 1920 × 1200 pixels (WUXGA)
Color reproduction	16.8 million colors
Brightness	White light output

	Normal Power Consumption Mode (ISO 21118 standard) (lumens)	ECO Power Consumption Mode (lumens)
G5450WUNL	4000	3200
G5550NL/G5650WNL/ G5750WUNL	4500	3600
G5950NL	5200	4160

Color light output

	Normal Power Consumption Mode (lumens)
G5450WUNL	4000
G5550NL/G5650WNL/ G5750WUNL	4500
G5950NL	5200

Contrast ratio	PowerLite Pro G5450WUNL/G5550NL: 1000:1 PowerLite Pro G5750WUNL: 1500:1 PowerLite Pro G5650WNL/G5950NL: 2000:1
Image size (includes all lenses)	PowerLite Pro G5450WUNL/G5750WUNL (16:10 image): 50 to 300 inches (127 to 762 centimeters) PowerLite Pro G5650WNL (16:10 image): 30 to 300 inches (76.2 to 762 centimeters) PowerLite Pro G5550NL/G5950NL (4:3 image): 30 to 300 inches (76.2 to 762 centimeters)
Projection distance (includes all lenses)	PowerLite Pro G5450WNL/G5750WUNL (16:10 image): 2.6 to 149.1 feet (0.8 to 45.5 meters) PowerLite Pro G5650WNL (16:10 image): 1.5 to 152.1 feet (0.5 to 46.4 meters) PowerLite Pro G5550NL/G5950NL (4:3 image): 1.5 to 144.6 feet (0.5 to 44.1 meters)
Projection methods	Front, rear, upside-down (ceiling mount)
Internal sound system	7 W monaural
Optical aspect ratio	PowerLite Pro G5550NL/G5950NL: 4:3 (horizontal:vertical) PowerLite Pro G5450WUNL/G5650WNL/G5750WUNL: 16:10 (horizontal:vertical)
Zoom ratio (standard lens, not included)	1:1.8
Noise level	PowerLite Pro G5450WUNL: 35 dB in Normal Power Consumption mode 30 dB in ECO Power Consumption mode PowerLite Pro G5550NL: 33 dB in Normal Power Consumption mode 28 dB in ECO Power Consumption mode PowerLite Pro G5650WNL/G5950NL: 38 dB in Normal Power Consumption mode 32 dB in ECO Power Consumption mode PowerLite Pro G5750WUNL: 39 dB in Normal Power Consumption mode 33 dB in ECO Power Consumption mode

Keystone correction	PowerLite Pro G5450WUNL/G5750WUNL: ±30° vertical, ±20° horizontal (standard lens) PowerLite Pro G5550NL/G5650WNL/G5950NL: ±40° vertical, ±20° horizontal (standard lens)
Mouse compatibility	Requires optional Wireless IR Mouse Receiver (part number V12H007T16)

Projection Lamp

note

Lamp life will vary depending upon mode selected, environmental conditions, and usage. Brightness decreases over time.

Turn off this product when not in use to prolong the life of the projector.

Type	UHE (Ultra High Efficiency)
Power consumption	PowerLite Pro G5450WUNL/G5550NL: 275 W PowerLite Pro G5650WNL/G5750WUNL/G5950NL: 330 W
Lamp life	Approx. 2000 hours (Normal Power Consumption mode) Approx. 3000 hours (ECO Power Consumption mode)
Part number	PowerLite Pro G5450WUNL/G5550NL: V13H010L62 PowerLite Pro G5650WNL/G5750WUNL/G5950NL: V13H010L63

Remote Control

Range	49.2 feet (15 meters)
Batteries (2)	Alkaline AA

Dimensions

Height	5.3 inches (135 mm), feet retracted
Width	18.5 inches (470 mm)
Depth	12.3 inches (311.5 mm), not including lens
Weight (without lens)	13.7 lb (6.2 kg)

Electrical

Rated frequency	50/60 Hz AC
Power supply	Powerlite Pro G5450WUNL: 100/240 VAC, 4.2 A/1.8 A Powerlite Pro G5550NL: 100/240 VAC, 3.9 A/1.7 A PowerLite Pro G5650WNL/G5950NL: 100/240 VAC, 4.7 A/2.0 A Powerlite Pro G5750WUNL: 100/240 VAC, 4.8 A/2.1 A
Power consumption	PowerLite Pro G5450WUNL: Operating: 100 to 120 VAC 413 W (Normal Power Consumption mode) 345 W (ECO Power Consumption mode) 220 to 240 VAC 393W (Normal Power Consumption mode) 330 W (ECO Power Consumption mode) Standby: 100 to 120 VAC 0.38 W (Communication off) 10 W (Communication on) 220 to 240 VAC 0.47 W (Communication off) 11 W (Communication on) PowerLite Pro G5550NL: Operating: 100 to 120 VAC 390 W (Normal Power Consumption mode) 323 W (ECO Power Consumption mode) 220 to 240 VAC 373 W (Normal Power Consumption mode) 311 W (ECO Power Consumption mode) Standby: 100 to 120 VAC 0.38 W (Communication off) 10 W (Communication on) 220 to 240 VAC 0.47 W (Communication off) 11 W (Communication on)

PowerLite Pro G5650WNL/G5950NL:

Operating:

100 to 120 VAC

464 W (Normal Power Consumption mode)

383 W (ECO Power Consumption mode)

220 to 240 VAC

442 W (Normal Power Consumption mode)

367 W (ECO Power Consumption mode)

Standby:

100 to 120 VAC

0.38 W (Communication off)

10 W (Communication on)

220 to 240 VAC

0.47 W (Communication off)

11 W (Communication on)

PowerLite Pro G5750WUNL:

Operating:

100 to 120 VAC

477 W (Normal Power Consumption mode)

394 W (ECO Power Consumption mode)

220 to 240 VAC

451 W (Normal Power Consumption mode)

376 W (ECO Power Consumption mode)

Standby:

100 to 120 VAC

0.38 W (Communication off)

10 W (Communication on)

220 to 240 VAC

0.47 W (Communication off)

11 W (Communication on)

Environmental

Temperature

Operating: 32 to 104 °F (0 to 40 °C)

32 to 95 °F (0 to 35 °C) (over 4,900 ft/1,500 m, with High Altitude Mode and Normal Power Consumption mode active)

Storage: 14 to 140 °F (-10 to 60 °C)

Humidity

(non-condensing)

Operating: 20 to 80% RH

Operating altitude 0 to 9,800 ft (0 to 3,000 m) (over 4,900 ft/1,500 m, with High Altitude Mode active)

Safety and Approvals

United States FCC 47CFR Part 15B Class B (DoC)
UL60950-1 Second Edition (cTUVus Mark)

Canada ICES-003 Class B
CSA C22.2 No. 60950-1-07 (cTUVus Mark)



Pixelworks™ DNX™ ICs are used in this projector.

Compatible Video Formats

These projectors support the high definition video and computer display formats listed in this section, as well as traditional NTSC, PAL, and SECAM video standards.

To project images output from a computer, the computer's video card must be set at a refresh rate (vertical frequency) that's compatible with the projector. Some images are automatically resized using Epson's SizeWize™ technology to display in the projector's native format. The frequencies of some computers may not allow images to display correctly; see your computer's documentation for details.

Computer signals (analog RGB)

Mode	Refresh Rate (Hz)	Resolution
VGA—60	60	640 × 480
VESA—72	72	640 × 480
VESA—75	75	640 × 480
VESA—85	85	640 × 480
SVGA—56	56	800 × 600
SVGA—60	60	800 × 600
SVGA—72	72	800 × 600
SVGA—75	75	800 × 600
SVGA—85	85	800 × 600
XGA—60	60	1024 × 768
XGA—70	70	1024 × 768
XGA—75	75	1024 × 768
XGA—85	85	1024 × 768

Computer signals (analog RGB) (continued)

Mode	Refresh Rate (Hz)	Resolution
SXGA1—70	70	1152 × 864
SXGA1—75	75	1152 × 864
SXGA1—85	85	1152 × 864
WXGA—60	60	1280 × 800
WXGA—75	75	1280 × 800
WXGA—85	85	1280 × 800
SXGA2—60	60	1280 × 960
SXGA2—75	75	1280 × 960
SXGA2—85	85	1280 × 960
SXGA3—60	60	1280 × 1024
SXGA3—75	75	1280 × 1024
SXGA3—85	85	1280 × 1024
WXGA1—60	60	1280 × 768
WXGA2—60	60	1360 × 768
WXGA+60	60	1440 × 900
WXGA+75	75	1440 × 900
WXGA+85	85	1440 × 900
SXGA+60	60	1400 × 1050
SXGA+75	75	1400 × 1050
UXGA—60	60	1600 × 1200
WSXGA+60*	60	1680 × 1050
WUXGA—60**	60	1920 × 1200
MAC13	67	640 × 480
MAC16	75	832 × 624
MAC19	75	1024 × 768
MAC19-60	59	1024 × 768
MAC21	75	1152 × 870

* Available only when **Wide** is selected as the Resolution with the PowerLite Pro G5450WUNL/G5650WNL/G5750WUNL.

** Available only when a VESA CVT-RB (Reduced Blanking) signal is input with the PowerLite G5450WUNL/G5750WUNL.

Component video

Mode	Refresh Rate (Hz)	Resolution
TV525i (480i)	60	720 × 480
TV625i (576i)	50	720 × 576
SDTV525p (480p)	60	720 × 480
SDTV625p (576p)	50	720 × 576
HDTV750p (720p)	60	1280 × 720
HDTV750p (720p)	50	1280 × 720
HDTV1125i (1080i)	60	1920 × 1080
HDTV1125i (1080i)	50	1920 × 1080

Composite video/S-Video

Mode	Refresh Rate (Hz)	Resolution
NTSC	60	720 × 480
NTSC 4:43	60	720 × 480
PAL	50	720 × 576
N-PAL	50	720 × 576
M-PAL	60	720 × 576
PAL—60	60	720 × 576
SECAM	50	720 × 576

Signals input through the DVI-D (G5450WUNL/G5750WUNL only) or HDMI ports

Mode	Refresh Rate (Hz)	Resolution
VGA—60	60	640 × 480
SVGA—60	60	800 × 600
XGA—60	60	1024 × 768
WXGA—60	60	1280 × 800
SXGA2—60	60	1280 × 960
SXGA3—60	60	1280 × 1024
SXGA+60	60	1400 × 1050
UXGA—60	60	1600 × 1200
WUXGA—60*	60	1920 × 1200

Signals input through the DVI-D (G5450WUNL/G5750WUNL only) or HDMI ports (continued)

Mode	Refresh Rate (Hz)	Resolution
TV525i (480i)	60	720 × 480
TV625i (576i)	50	720 × 576
SDTV525p (480p)	60	720 × 480
SDTV625p (576p)	50	720 × 576
HDTV750p (720p)	60	1280 × 720
HDTV750p (720p)	50	1280 × 720
HDTV1125i (1080i)	60	1920 × 1080
HDTV1125i (1080i)	50	1920 × 1080
HDTV1125p (1080p)	60	1920 × 1080
HDTV1125p (1080p)	50	1920 × 1080
HDTV1125p (1080p)	30	1920 × 1080
HDTV1125p (1080p)	24	1920 × 1080

* Available only when a VESA CVT-RB (Reduced Blanking) signal is input with the PowerLite G5450WUNL/G5750WUNL.

C

Notices

This appendix includes safety instructions and other important information about your projector.

Important Safety Instructions

Follow these safety instructions when setting up and using the projector:

- Do not look into the lens when the projector is on. The bright light can damage your eyes, and is especially dangerous for children and pets.
- Do not place the projector on an unstable cart, stand, or table.
- Do not operate the projector on its side, or while tilted to one side. Do not tilt the projector forward or back at a greater angle than that specified for vertical keystone correction (see page 171).
- If the projector is mounted on a ceiling, it should be installed by qualified technicians using mounting hardware designed for use with this projector. If the projector is not installed correctly, the projector may fall from its ceiling mount. This could cause serious injury to anyone under the mount and could damage the projector.
- If you use a ceiling mount and apply adhesives to the mount to prevent the screws from loosening, or if you use lubricants or oils on the projector, the projector case may crack and the projector may fall from its ceiling mount. This could cause serious injury to anyone under the mount and could damage the projector. When installing or adjusting a ceiling mount, do not use adhesives to prevent the screws from loosening and do not use oils or lubricants.
- Do not stand on the projector or place heavy objects on it.
- Do not use the projector where it may be exposed to rain, water, or excessive humidity.
- Unplug the projector from the wall outlet before cleaning. Use a dry cloth (or, for stubborn dirt or stains, a moist cloth that has been wrung dry) for cleaning. Do not use liquid or aerosol cleaners, or solvents such as alcohol, thinner, or benzine.

- Do not use sprays containing flammable gas to clean the lens or filter. Do not spray a liquid of any kind directly on the projector or its lens. Do not use the projector where there may be flammable, explosive, or corrosive gases present in the atmosphere.
- Do not place containers of liquid on top of the projector. Never spill liquid of any kind into the projector.
- Do not use the projector where it may be exposed to smoke, steam, or excessive dust.
- Never insert or drop objects of any kind through the projector's vents or openings. Do not leave metal, flammable, or foreign objects nearby.
- Do not use or store the projector or remote control in a hot location, such as near a heater, in direct sunlight, or in a closed vehicle.
- Do not block the slots and openings in the projector case. They provide ventilation and prevent the projector from overheating. Do not operate the projector on a sofa, rug, or other soft surface. If you are setting up the projector near a wall, leave at least 7.9 inches (20 cm) of space between the wall and the air exhaust vent.
- Do not operate the projector in a closed-in cabinet unless proper ventilation is provided.
- If you are using two or more projectors side-by-side, leave at least 2 feet (60 cm) of space between the projectors to allow for proper ventilation.
- You may need to clean the air filter and vent. A clogged air filter or vent can block ventilation needed to cool the projector.
- Do not store the projector outdoors for an extended length of time.
- Do not use the projector outside the required temperature range (see page 173). Doing so may cause an unstable display and could lead to projector damage.
- Do not store the projector outside the required temperature range (see page 173) or in direct sunlight for long periods of time. Doing so may cause damage to the case.
- Do not touch the plug during an electrical storm. Otherwise, you may receive an electric shock.
- Unplug the projector when it will not be used for extended periods. Place the projector near an outlet where the plug can be easily unplugged.
- Remove the batteries from the remote control if you will not be using the projector for a long period of time.
- Unplug the projector from the wall outlet and refer servicing to qualified service personnel under the following conditions: if it does not operate normally when you follow the operating instructions, or exhibits a

distinct change in performance; if smoke, strange odors, or strange noises come from the projector; if the power cord or plug is damaged or frayed; if liquid or foreign objects get inside the projector, or if it has been exposed to rain or water; if it has been dropped or the housing has been damaged.

- Except as specifically explained in this *User's Guide*, do not attempt to service this product yourself. Refer all servicing to qualified personnel. Opening or removing covers may expose you to dangerous voltages and other hazards.
- Never open any covers on the projector except as specifically explained in this *User's Guide*. Never attempt to disassemble or modify the projector (including consumables). Refer all repairs to qualified service personnel.
- Use the type of power source indicated on the projector. Use of a different power source may result in fire or electric shock. If you are not sure of the power available, consult your dealer or power company.
- If you use the projector in the country where it was purchased, only use the power cable that came with the projector. If you use the projector in a country other than where you purchased it, use the correct power cord for that country.
- Take the following precautions when handling the plug: Do not overload wall outlets, extension cords, or power strips. Do not hold the plug with wet hands. Do not insert the plug into a dusty outlet. Insert the plug firmly into the outlet. Do not pull the power cord when disconnecting the plug; always be sure to hold the plug when disconnecting it. Failure to comply with these precautions could result in fire or electric shock.
- Do not place anything that can become warped or damaged by heat near the exhaust vents. Do not bring your hands or face close to the vents while projection is in progress.
- Before you move the projector, make sure its power is turned off, the plug is disconnected from the outlet, and all cables are disconnected.
- Do not project images while the detachable lens cover is still attached. Heat may cause the lens cover to melt, and if you touch the lens cover you could get burned.
- Do not block the light coming from the projector with any object. The object may be damaged or the reflected light may heat the lens and damage the projector.
- Do not touch the lens with bare hands.
- Always attach the lens cover to the lens when not using the projector, to prevent the lens from becoming dirty or damaged.

- Never try to remove the lamp immediately after use because it will be extremely hot. Before removing the lamp, turn off the power and wait at least an hour to allow the lamp to cool completely.
- Do not place the source of an open flame, such as a lit candle, on or near the projector.
- Do not modify the power cord. Do not place heavy objects on top of the power cord or bend, twist, or pull it excessively. Keep the power cord away from hot electrical appliances. Do not place the projector where the cord can be walked on.
- (Hg) The lamp(s) in this product contain mercury. Please consult your state and local regulations regarding disposal or recycling. Do not put in the trash.
- The gases inside the lamp contain mercury vapor. If the lamp breaks, ventilate the room to prevent gases contained in the lamp from being inhaled or coming in contact with the eyes or mouth.
- If the projector is mounted overhead and the lamp breaks, small pieces of glass may fall down when you remove the lamp cover. Be careful to prevent pieces of glass from getting into your eyes or mouth.
- If the lamp breaks and gases or fragments of broken glass from the lamp are inhaled or get into the eyes or mouth, or if any other ill effects are noticed, immediately seek medical advice.
- Do not disassemble or damage the lamp or subject it to any impacts.
- Do not start the projector while the volume is too high.
- Do not use the projector where there may be low or high temperature extremes or sudden changes in temperature.
- Do not set up the projector where it may be subjected to vibrations or shocks, or near high-voltage electrical wires or sources of magnetic fields.

WARNING: The cords included with this product contain chemicals, including lead, known to the State of California to cause birth defects or other reproductive harm. *Wash hands after handling.* (This notice is provided in accordance with Proposition 65 in Cal. Health & Safety Code §25249.5 and following.)

FCC Compliance Statement

For United States Users

This equipment has been tested and found to comply with the limits for a Class B digital device, pursuant to Part 15 of the FCC Rules. These limits are designed to provide reasonable protection against harmful interference in a residential installation. This equipment generates, uses, and can radiate radio frequency energy and, if not installed and used in accordance with the instructions, may cause harmful interference to radio communications. However, there is no guarantee that interference will not occur in a particular installation. If this equipment does cause interference to radio or television reception, which can be determined by turning the equipment off and on, the user is encouraged to try to correct the interference by one or more of the following measures:

- Reorient or relocate the receiving antenna.
- Increase the separation between the equipment and receiver.
- Connect the equipment into an outlet on a circuit different from that to which the receiver is connected.
- Consult the dealer or an experienced radio/TV technician for help.

WARNING

The connection of a non-shielded equipment interface cable to this equipment will invalidate the FCC Certification or Declaration of this device and may cause interference levels which exceed the limits established by the FCC for this equipment. It is the responsibility of the user to obtain and use a shielded equipment interface cable with this device. If this equipment has more than one interface connector, do not leave cables connected to unused interfaces. Changes or modifications not expressly approved by the manufacturer could void the user's authority to operate the equipment.

For Canadian Users

This Class B digital apparatus complies with Canadian ICES-003.

Cet appareil numérique de la classe B est conforme à la norme NMB-003 du Canada.

Software Copyright

This product uses free software as well as software to which this company holds the rights.

The following is information on the free software used by this product.

1. LGPL

(1) This company uses free software for this product under the terms of the GNU LESSER General Public License Version 2, June 1991 (henceforth "LGPL") or later versions.

You can see the full text of the LGPL on the following Web sites.

[LGPL]<http://www.gnu.org/licenses/gpl.html>

This company, under the terms of the LGPL, discloses the source code for the free software used in this product based on the LGPL.

Contact the Epson support personnel to reproduce, modify, and/or distribute the free software concerned.

Please follow the conditions of the LGPL when reproducing, modifying, and/or distributing the free software concerned.

Also, the free software concerned is offered "as is" with no guarantee or warranty what so ever. The term guarantee includes, but is not limited to, appropriate commercialization, business potential, purpose of use, and does not infringe on third person rights (including, but not limited to, patent rights, copyrights, and trade secrets).

(2) Furthermore, as stated in (1), there is no guarantee for free software that is included in this product to which the LGPL applies because of the characteristics of the free software that has already used in this product; any problems in this product (including problems that originate with the free software concerned) do not influence the conditions of the guarantee (written guarantee) issued by this company.

(3) Under the terms of the LGPL, the source code as well as authorship for the free software used in this product is disclosed as stated in (1).

2. Other free software

As well as the free software used under the terms of the LGPL, this company also uses the following free software for this product. Hereafter, each author, the conditions, and so on are described in the original. Furthermore, there is no guarantee for free software because of the characteristics of the free software that has already been used in this product; any problems in this product (including problems that originate with the free software concerned) do not influence the conditions of the guarantee (written guarantee) issued by this company.

(1) libpng

Copyright© 1998-2004 Glenn Randers-Pehrson

Copyright© 1996-1997 Andreas Dilger

Copyright© 1995-1996 Guy Eric Schalnat, Group 42, Inc.

(2) zlib

Copyright© 1995-2003 Jean-loup Gailly and Mark Adler

GNU GPL

This projector product includes the open source software programs which apply the GNU General Public License Version 2 or later version ("GPL Programs").

We provide the source code of the GPL Programs until five (5) years after the discontinuation of same model of this projector product.

If you desire to receive the source code of the GPL Programs, please contact the customer support of your region.

These GPL Programs are WITHOUT ANY WARRANTY; without even the implied warranty of MERCHANTABILITY AND FITNESS FOR A PARTICULAR PURPOSE. See the GNU General Public License for more details.

The list of GPL Programs is as follows and the names of author are described in the source code of the GPL Programs

The list of GPL Programs

busybox-1.7.2

libgcc1(gcc-4.2.3)

linux-2.6.20

patches

udhcp 0.9.8

uvc rev.219

wireless_tools 29

Pixelworks PWC950 SDK drivers

The GNU General Public License Version 2 is as follows. You also can see the GNU General Public License Version 2 at <http://www.gnu.org/licenses/>.

GNU GENERAL PUBLIC LICENSE

Version 2, June 1991

Copyright (C) 1989, 1991 Free Software Foundation, Inc., 51 Franklin Street, Fifth Floor, Boston, MA 02110-1301 USA Everyone is permitted to copy and distribute verbatim copies of this license document, but changing it is not allowed.

Preamble

The licenses for most software are designed to take away your freedom to share and change it. By contrast, the GNU General Public License is intended to guarantee your freedom to share and change free software—to make sure the software is free for all its users. This General Public License applies to most of the Free Software Foundation's software and to any other program whose authors commit to using it. (Some other Free Software Foundation software is covered by the GNU Lesser General Public License instead.) You can apply it to your programs, too.

When we speak of free software, we are referring to freedom, not price. Our General Public Licenses are designed to make sure that you have the freedom to distribute copies of free software (and charge for this service if you wish), that you receive source code or can get it if you want it, that you can change the software or use pieces of it in new free programs; and that you know you can do these things.

To protect your rights, we need to make restrictions that forbid anyone to deny you these rights or to ask you to surrender the rights. These restrictions translate to certain responsibilities for you if you distribute copies of the software, or if you modify it.

For example, if you distribute copies of such a program, whether gratis or for a fee, you must give the recipients all the rights that you have. You must make sure that they, too, receive or can get the source code. And you must show them these terms so they know their rights.

We protect your rights with two steps: (1) copyright the software, and (2) offer you this license which gives you legal permission to copy, distribute and/or modify the software.

Also, for each author's protection and ours, we want to make certain that everyone understands that there is no warranty for this free software. If the software is modified by someone else and passed on, we want its recipients to know that what they have is not the original, so that any problems introduced by others will not reflect on the original authors' reputations.

Finally, any free program is threatened constantly by software patents. We wish to avoid the danger that redistributors of a free program will individually obtain patent licenses, in effect making the program proprietary. To prevent this, we have made it clear that any patent must be licensed for everyone's free use or not licensed at all.

The precise terms and conditions for copying, distribution and modification follow.

GNU GENERAL PUBLIC LICENSE TERMS AND CONDITIONS FOR COPYING, DISTRIBUTION AND MODIFICATION

0. This License applies to any program or other work which contains a notice placed by the copyright holder saying it may be distributed under the terms of this General Public License. The "Program", below, refers to any such program or work, and a "work based on the Program" means either the Program or any derivative work under copyright law: that is to say, a work containing the Program or a portion of it, either verbatim or with modifications and/or translated into another language. (Hereinafter, translation is included without limitation in the term "modification".) Each licensee is addressed as "you".

Activities other than copying, distribution and modification are not covered by this License; they are outside its scope. The act of running the Program is not restricted, and the output from the Program is covered only if its contents constitute a work based on the Program (independent of having been made by running the Program). Whether that is true depends on what the Program does.

1. You may copy and distribute verbatim copies of the Program's source code as you receive it, in any medium, provided that you conspicuously and appropriately publish on each copy an appropriate copyright notice and disclaimer of warranty; keep intact all the notices that refer to this License and to the absence of any warranty; and give any other recipients of the Program a copy of this License along with the Program.

You may charge a fee for the physical act of transferring a copy, and you may at your option offer warranty protection in exchange for a fee.

2. You may modify your copy or copies of the Program or any portion of it, thus forming a work based on the Program, and copy and distribute such modifications or work under the terms of Section 1 above, provided that you also meet all of these conditions:
 - a) You must cause the modified files to carry prominent notices stating that you changed the files and the date of any change.
 - b) You must cause any work that you distribute or publish, that in whole or in part contains or is derived from the Program or any part thereof, to be licensed as a whole at no charge to all third parties under the terms of this License.
 - c) If the modified program normally reads commands interactively when run, you must cause it, when started running for such interactive use in the most ordinary way, to print or display an announcement including an appropriate copyright notice and a notice that there is no warranty (or else, saying that you provide a warranty) and that users may redistribute the program under these conditions, and telling the user how to view a copy of this License. (Exception: if the Program itself is interactive but does not normally print such an announcement, your work based on the Program is not required to print an announcement.)

These requirements apply to the modified work as a whole. If identifiable sections of that work are not derived from the Program, and can be reasonably considered independent and separate works in themselves, then this License, and its terms, do not apply to those sections when you distribute them as separate works. But when you distribute the same sections as part of a whole which is a work based on the Program, the distribution of the whole must be on the terms of this License, whose permissions for other licensees extend to the entire whole, and thus to each and every part regardless of who wrote it.

Thus, it is not the intent of this section to claim rights or contest your rights to work written entirely by you; rather, the intent is to exercise the right to control the distribution of derivative or collective works based on the Program.

In addition, mere aggregation of another work not based on the Program with the Program (or with a work based on the Program) on a volume of a storage or distribution medium does not bring the other work under the scope of this License.

3. You may copy and distribute the Program (or a work based on it, under Section 2) in object code or executable form under the terms of Sections 1 and 2 above provided that you also do one of the following:
 - a) Accompany it with the complete corresponding machine-readable source code, which must be distributed under the terms of Sections 1 and 2 above on a medium customarily used for software interchange; or,
 - b) Accompany it with a written offer, valid for at least three years, to give any third party, for a charge no more than your cost of physically performing source distribution, a complete machine-readable copy of the corresponding source code, to be distributed under the terms of Sections 1 and 2 above on a medium customarily used for software interchange; or,
 - c) Accompany it with the information you received as to the offer to distribute corresponding source code. (This alternative is allowed only for noncommercial distribution and only if you received the program in object code or executable form with such an offer, in accord with Subsection b above.)

The source code for a work means the preferred form of the work for making modifications to it. For an executable work, complete source code means all the source code for all modules it contains, plus any associated interface definition files, plus the scripts used to control compilation and installation of the executable. However, as a special exception, the source code distributed need not include anything that is normally distributed (in either source or binary form) with the major components (compiler, kernel, and so on) of the operating system on which the executable runs, unless that component itself accompanies the executable.

If distribution of executable or object code is made by offering access to copy from a designated place, then offering equivalent access to copy the source code from the same place counts as distribution of the source code, even though third parties are not compelled to copy the source along with the object code.

4. You may not copy, modify, sublicense, or distribute the Program except as expressly provided under this License. Any attempt otherwise to copy, modify, sublicense or distribute the Program is void, and will automatically terminate your rights under this License. However, parties who have received copies, or rights, from you under this License will not have their licenses terminated so long as such parties remain in full compliance.

5. You are not required to accept this License, since you have not signed it. However, nothing else grants you permission to modify or distribute the Program or its derivative works. These actions are prohibited by law if you do not accept this License. Therefore, by modifying or distributing the Program (or any work based on the Program), you indicate your acceptance of this License to do so, and all its terms and conditions for copying, distributing or modifying the Program or works based on it.
6. Each time you redistribute the Program (or any work based on the Program), the recipient automatically receives a license from the original licensor to copy, distribute or modify the Program subject to these terms and conditions. You may not impose any further restrictions on the recipients' exercise of the rights granted herein. You are not responsible for enforcing compliance by third parties to this License.
7. If, as a consequence of a court judgment or allegation of patent infringement or for any other reason (not limited to patent issues), conditions are imposed on you (whether by court order, agreement or otherwise) that contradict the conditions of this License, they do not excuse you from the conditions of this License. If you cannot distribute so as to satisfy simultaneously your obligations under this License and any other pertinent obligations, then as a consequence you may not distribute the Program at all. For example, if a patent license would not permit royalty-free redistribution of the Program by all those who receive copies directly or indirectly through you, then the only way you could satisfy both it and this License would be to refrain entirely from distribution of the Program.

If any portion of this section is held invalid or unenforceable under any particular circumstance, the balance of the section is intended to apply and the section as a whole is intended to apply in other circumstances.

It is not the purpose of this section to induce you to infringe any patents or other property right claims or to contest validity of any such claims; this section has the sole purpose of protecting the integrity of the free software distribution system, which is implemented by public license practices. Many people have made generous contributions to the wide range of software distributed through that system in reliance on consistent application of that system; it is up to the author/donor to decide if he or she is willing to distribute software through any other system and a licensee cannot impose that choice.

This section is intended to make thoroughly clear what is believed to be a consequence of the rest of this License.

8. If the distribution and/or use of the Program is restricted in certain countries either by patents or by copyrighted interfaces, the original copyright holder who places the Program under this License may add an explicit geographical distribution limitation excluding those countries, so that distribution is permitted only in or among countries not thus excluded. In such case, this License incorporates the limitation as if written in the body of this License.

9. The Free Software Foundation may publish revised and/or new versions of the General Public License from time to time. Such new versions will be similar in spirit to the present version, but may differ in detail to address new problems or concerns.

Each version is given a distinguishing version number. If the Program specifies a version number of this License which applies to it and "any later version", you have the option of following the terms and conditions either of that version or of any later version published by the Free Software Foundation. If the Program does not specify a version number of this License, you may choose any version ever published by the Free Software Foundation.

10. If you wish to incorporate parts of the Program into other free programs whose distribution conditions are different, write to the author to ask for permission. For software which is copyrighted by the Free Software Foundation, write to the Free Software Foundation; we sometimes make exceptions for this. Our decision will be guided by the two goals of preserving the free status of all derivatives of our free software and of promoting the sharing and reuse of software generally.

NO WARRANTY

11. BECAUSE THE PROGRAM IS LICENSED FREE OF CHARGE, THERE IS NO WARRANTY FOR THE PROGRAM, TO THE EXTENT PERMITTED BY APPLICABLE LAW. EXCEPT WHEN OTHERWISE STATED IN WRITING THE COPYRIGHT HOLDERS AND/OR OTHER PARTIES PROVIDE THE PROGRAM "AS IS" WITHOUT WARRANTY OF ANY KIND, EITHER EXPRESSED OR IMPLIED, INCLUDING, BUT NOT LIMITED TO, THE IMPLIED WARRANTIES OF MERCHANTABILITY AND FITNESS FOR A PARTICULAR PURPOSE. THE ENTIRE RISK AS TO THE QUALITY AND PERFORMANCE OF THE PROGRAM IS WITH YOU. SHOULD THE PROGRAM PROVE DEFECTIVE, YOU ASSUME THE COST OF ALL NECESSARY SERVICING, REPAIR OR CORRECTION.
12. IN NO EVENT UNLESS REQUIRED BY APPLICABLE LAW OR AGREED TO IN WRITING WILL ANY COPYRIGHT HOLDER, OR ANY OTHER PARTY WHO MAY MODIFY AND/OR REDISTRIBUTE THE PROGRAM AS PERMITTED ABOVE, BE LIABLE TO YOU FOR DAMAGES, INCLUDING ANY GENERAL, SPECIAL, INCIDENTAL OR CONSEQUENTIAL DAMAGES ARISING OUT OF THE USE OR INABILITY TO USE THE PROGRAM (INCLUDING BUT NOT LIMITED TO LOSS OF DATA OR DATA BEING RENDERED INACCURATE OR LOSSES SUSTAINED BY YOU OR THIRD PARTIES OR A FAILURE OF THE PROGRAM TO OPERATE WITH ANY OTHER PROGRAMS), EVEN IF SUCH HOLDER OR OTHER PARTY HAS BEEN ADVISED OF THE POSSIBILITY OF SUCH DAMAGES.

END OF TERMS AND CONDITIONS

How to Apply These Terms to Your New Programs

If you develop a new program, and you want it to be of the greatest possible use to the public, the best way to achieve this is to make it free software which everyone can redistribute and change under these terms.

To do so, attach the following notices to the program. It is safest to attach them to the start of each source file to most effectively convey the exclusion of warranty; and each file should have at least the "copyright" line and a pointer to where the full notice is found.

```
<one line to give the program's name and a brief idea of what it does.>  
Copyright (C) <year> <name of author>
```

```
This program is free software; you can redistribute it and/or modify it under the  
terms of the GNU General Public License as published by the Free Software  
Foundation; either version 2 of the License, or (at your option) any later version.
```

```
This program is distributed in the hope that it will be useful, but WITHOUT ANY  
WARRANTY; without even the implied warranty of MERCHANTABILITY or  
FITNESS FOR A PARTICULAR PURPOSE. See the GNU General Public License  
for more details.
```

```
You should have received a copy of the GNU General Public License along with  
this program; if not, write to the Free Software Foundation, Inc., 51 Franklin  
Street, Fifth Floor, Boston, MA 02110-1301 USA.
```

Also add information on how to contact you by electronic and paper mail.

If the program is interactive, make it output a short notice like this when it starts in an interactive mode:

```
Gnomovision version 69, Copyright (C) year name of author Gnomovision comes  
with ABSOLUTELY NO WARRANTY; for details type `show w'. This is free  
software, and you are welcome to redistribute it under certain conditions; type  
`show c' for details.
```

The hypothetical commands `show w' and `show c' should show the appropriate parts of the General Public License. Of course, the commands you use may be called something other than `show w' and `show c'; they could even be mouse-clicks or menu items--whatever suits your program.

You should also get your employer (if you work as a programmer) or your school, if any, to sign a "copyright disclaimer" for the program, if necessary. Here is a sample; alter the names:

```
Yoyodyne, Inc., hereby disclaims all copyright interest in the program  
'Gnomovision' (which makes passes at compilers) written by James Hacker.
```

```
<signature of Ty Coon>, 1 April 1989  
Ty Coon, President of Vice
```

This General Public License does not permit incorporating your program into proprietary programs. If your program is a subroutine library, you may consider it more useful to permit linking proprietary applications with the library. If this is what you want to do, use the GNU Lesser General Public License instead of this License.

GNU LGPL

This projector product includes the open source software programs which apply the GNU Lesser General Public License Version 2 or later version ("LGPL Programs"). We provide the source code of the LGPL Programs until five (5) years after the discontinuation of same model of this projector product. If you desire to receive the source code of the LGPL Programs, please contact the customer support of your region.

These LGPL Programs are WITHOUT ANY WARRANTY; without even the implied warranty of MERCHANTABILITY AND FITNESS FOR A PARTICULAR PURPOSE. See the GNU General Public License for more details.

The list of LGPL Programs is as follows and the names of author are described in the source code of the LGPL Programs.

LGPL Programs

uClibc-0.9.29

SDL-1.2.13

The GNU Lesser General Public License Version 2 is as follows. You also can see the GNU Lesser General Public License Version 2 at <http://www.gnu.org/licenses/>.

GNU LESSER GENERAL PUBLIC LICENSE

Version 2.1, February 1999

Copyright (C) 1991, 1999 Free Software Foundation, Inc. 51 Franklin Street, Fifth Floor, Boston, MA 02110-1301 USA Everyone is permitted to copy and distribute verbatim copies of this license document, but changing it is not allowed.

[This is the first released version of the Lesser GPL. It also counts as the successor of the GNU Library Public License, version 2, hence the version number 2.1.]

Preamble

The licenses for most software are designed to take away your freedom to share and change it. By contrast, the GNU General Public Licenses are intended to guarantee your freedom to share and change free software—to make sure the software is free for all its users.

This license, the Lesser General Public License, applies to some specially designated software packages—typically libraries—of the Free Software Foundation and other authors who decide to use it. You can use it too, but we suggest you first think carefully about whether this license or the ordinary General Public License is the better strategy to use in any particular case, based on the explanations below.

When we speak of free software, we are referring to freedom of use, not price. Our General Public Licenses are designed to make sure that you have the freedom to distribute copies of free software (and charge for this service if you wish); that you receive source code or can get it if you want it; that you can change the software and use pieces of it in new free programs; and that you are informed that you can do these things.

To protect your rights, we need to make restrictions that forbid distributors to deny you these rights or to ask you to surrender these rights. These restrictions translate to certain responsibilities for you if you distribute copies of the library or if you modify it.

For example, if you distribute copies of the library, whether gratis or for a fee, you must give the recipients all the rights that we gave you. You must make sure that they, too, receive or can get the source code. If you link other code with the library, you must provide complete object files to the recipients, so that they can relink them with the library after making changes to the library and recompiling it. And you must show them these terms so they know their rights.

We protect your rights with a two-step method: (1) we copyright the library, and (2) we offer you this license, which gives you legal permission to copy, distribute and/or modify the library.

To protect each distributor, we want to make it very clear that there is no warranty for the free library. Also, if the library is modified by someone else and passed on, the recipients should know that what they have is not the original version, so that the original author's reputation will not be affected by problems that might be introduced by others.

Finally, software patents pose a constant threat to the existence of any free program. We wish to make sure that a company cannot effectively restrict the users of a free program by obtaining a restrictive license from a patent holder. Therefore, we insist that any patent license obtained for a version of the library must be consistent with the full freedom of use specified in this license.

Most GNU software, including some libraries, is covered by the ordinary GNU General Public License. This license, the GNU Lesser General Public License, applies to certain designated libraries, and is quite different from the ordinary General Public License. We use this license for certain libraries in order to permit linking those libraries into non-free programs.

When a program is linked with a library, whether statically or using a shared library, the combination of the two is legally speaking a combined work, a derivative of the original library. The ordinary General Public License therefore permits such linking only if the entire combination fits its criteria of freedom. The Lesser General Public License permits more lax criteria for linking other code with the library.

We call this license the "Lesser" General Public License because it does Less to protect the user's freedom than the ordinary General Public License. It also provides other free software developers Less of an advantage over competing non-free programs. These disadvantages are the reason we use the ordinary General Public License for many libraries. However, the Lesser license provides advantages in certain special circumstances.

For example, on rare occasions, there may be a special need to encourage the widest possible use of a certain library, so that it becomes a de-facto standard. To achieve this, non-free programs must be allowed to use the library. A more frequent case is that a free library does the same job as widely used non-free libraries. In this case, there is little to gain by limiting the free library to free software only, so we use the Lesser General Public License.

In other cases, permission to use a particular library in non-free programs enables a greater number of people to use a large body of free software. For example, permission to use the GNU C Library in non-free programs enables many more people to use the whole GNU operating system, as well as its variant, the GNU/Linux operating system.

Although the Lesser General Public License is Less protective of the users' freedom, it does ensure that the user of a program that is linked with the Library has the freedom and the wherewithal to run that program using a modified version of the Library.

The precise terms and conditions for copying, distribution and modification follow. Pay close attention to the difference between a "work based on the library" and a "work that uses the library". The former contains code derived from the library, whereas the latter must be combined with the library in order to run.

GNU LESSER GENERAL PUBLIC LICENSE TERMS AND CONDITIONS FOR COPYING, DISTRIBUTION AND MODIFICATION

0. This License Agreement applies to any software library or other program which contains a notice placed by the copyright holder or other authorized party saying it may be distributed under the terms of this Lesser General Public License (also called "this License"). Each licensee is addressed as "you".

A "library" means a collection of software functions and/or data prepared so as to be conveniently linked with application programs (which use some of those functions and data) to form executables.

The "Library", below, refers to any such software library or work which has been distributed under these terms. A "work based on the Library" means either the Library or any derivative work under copyright law: that is to say, a work containing the Library or a portion of it, either verbatim or with modifications and/or translated straightforwardly into another language. (Hereinafter, translation is included without limitation in the term "modification".)

"Source code" for a work means the preferred form of the work for making modifications to it. For a library, complete source code means all the source code for all modules it contains, plus any associated interface definition files, plus the scripts used to control compilation and installation of the library.

Activities other than copying, distribution and modification are not covered by this License; they are outside its scope. The act of running a program using the Library is not restricted, and output from such a program is covered only if its contents constitute a work based on the Library (independent of the use of the Library in a tool for writing it). Whether that is true depends on what the Library does and what the program that uses the Library does.

1. You may copy and distribute verbatim copies of the Library's complete source code as you receive it, in any medium, provided that you conspicuously and appropriately publish on each copy an appropriate copyright notice and disclaimer of warranty; keep intact all the notices that refer to this License and to the absence of any warranty; and distribute a copy of this License along with the Library.

You may charge a fee for the physical act of transferring a copy, and you may at your option offer warranty protection in exchange for a fee.

2. You may modify your copy or copies of the Library or any portion of it, thus forming a work based on the Library, and copy and distribute such modifications or work under the terms of Section 1 above, provided that you also meet all of these conditions:
 - a) The modified work must itself be a software library.
 - b) You must cause the files modified to carry prominent notices stating that you changed the files and the date of any change.
 - c) You must cause the whole of the work to be licensed at no charge to all third parties under the terms of this License.
 - d) If a facility in the modified Library refers to a function or a table of data to be supplied by an application program that uses the facility, other than as an argument passed when the facility is invoked, then you must make a good faith effort to ensure that, in the event an application does not supply such function or table, the facility still operates, and performs whatever part of its purpose remains meaningful.

(For example, a function in a library to compute square roots has a purpose that is entirely well-defined independent of the application. Therefore, Subsection 2d requires that any application-supplied function or table used by this function must be optional: if the application does not supply it, the square root function must still compute square roots.)

These requirements apply to the modified work as a whole. If identifiable sections of that work are not derived from the Library, and can be reasonably considered independent and separate works in themselves, then this License, and its terms, do not apply to those sections when you distribute them as separate works. But when you distribute the same sections as part of a whole which is a work based on the Library, the distribution of the whole must be on the terms of this License, whose permissions for other licensees extend to the entire whole, and thus to each and every part regardless of who wrote it.

Thus, it is not the intent of this section to claim rights or contest your rights to work written entirely by you; rather, the intent is to exercise the right to control the distribution of derivative or collective works based on the Library.

In addition, mere aggregation of another work not based on the Library with the Library (or with a work based on the Library) on a volume of a storage or distribution medium does not bring the other work under the scope of this License.

3. You may opt to apply the terms of the ordinary GNU General Public License instead of this License to a given copy of the Library. To do this, you must alter all the notices that refer to this License, so that they refer to the ordinary GNU General Public License, version 2, instead of to this License. (If a newer version than version 2 of the ordinary GNU General Public License has appeared, then you can specify that version instead if you wish.) Do not make any other change in these notices.

Once this change is made in a given copy, it is irreversible for that copy, so the ordinary GNU General Public License applies to all subsequent copies and derivative works made from that copy.

This option is useful when you wish to copy part of the code of the Library into a program that is not a library.

4. You may copy and distribute the Library (or a portion or derivative of it, under Section 2) in object code or executable form under the terms of Sections 1 and 2 above provided that you accompany it with the complete corresponding machine-readable source code, which must be distributed under the terms of Sections 1 and 2 above on a medium customarily used for software interchange.

If distribution of object code is made by offering access to copy from a designated place, then offering equivalent access to copy the source code from the same place satisfies the requirement to distribute the source code, even though third parties are not compelled to copy the source along with the object code.

5. A program that contains no derivative of any portion of the Library, but is designed to work with the Library by being compiled or linked with it, is called a "work that uses the Library". Such a work, in isolation, is not a derivative work of the Library, and therefore falls outside the scope of this License.

However, linking a "work that uses the Library" with the Library creates an executable that is a derivative of the Library (because it contains portions of the Library), rather than a "work that uses the library". The executable is therefore covered by this License. Section 6 states terms for distribution of such executables.

When a "work that uses the Library" uses material from a header file that is part of the Library, the object code for the work may be a derivative work of the Library even though the source code is not. Whether this is true is especially significant if the work can be linked without the Library, or if the work is itself a library. The threshold for this to be true is not precisely defined by law.

If such an object file uses only numerical parameters, data structure layouts and accessors, and small macros and small inline functions (ten lines or less in length), then the use of the object file is unrestricted, regardless of whether it is legally a derivative work. (Executables containing this object code plus portions of the Library will still fall under Section 6.)

Otherwise, if the work is a derivative of the Library, you may distribute the object code for the work under the terms of Section 6. Any executables containing that work also fall under Section 6, whether or not they are linked directly with the Library itself.

6. As an exception to the Sections above, you may also combine or link a "work that uses the Library" with the Library to produce a work containing portions of the Library, and distribute that work under terms of your choice, provided that the terms permit modification of the work for the customer's own use and reverse engineering for debugging such modifications.

You must give prominent notice with each copy of the work that the Library is used in it and that the Library and its use are covered by this License. You must supply a copy of this License. If the work during execution displays copyright notices, you must include the copyright notice for the Library among them, as well as a reference directing the user to the copy of this License. Also, you must do one of these things:

- a) Accompany the work with the complete corresponding machine-readable source code for the Library including whatever changes were used in the work (which must be distributed under Sections 1 and 2 above); and, if the work is an executable linked with the Library, with the complete machine-readable "work that uses the Library", as object code and/or source code, so that the user can modify the Library and then relink to produce a modified executable containing the modified Library. (It is understood that the user who changes the contents of definitions files in the Library will not necessarily be able to recompile the application to use the modified definitions.)
- b) Use a suitable shared library mechanism for linking with the Library. A suitable mechanism is one that (1) uses at run time a copy of the library already present on the user's computer system, rather than copying library functions into the executable, and (2) will operate properly with a modified version of the library, if the user installs one, as long as the modified version is interface-compatible with the version that the work was made with.
- c) Accompany the work with a written offer, valid for at least three years, to give the same user the materials specified in Subsection 6a, above, for a charge no more than the cost of performing this distribution.
- d) If distribution of the work is made by offering access to copy from a designated place, offer equivalent access to copy the above specified materials from the same place.
- e) Verify that the user has already received a copy of these materials or that you have already sent this user a copy.

For an executable, the required form of the "work that uses the Library" must include any data and utility programs needed for reproducing the executable from it. However, as a special exception, the materials to be distributed need not include anything that is normally distributed (in either source or binary form) with the major components (compiler, kernel, and so on) of the operating system on which the executable runs, unless that component itself accompanies the executable.

It may happen that this requirement contradicts the license restrictions of other proprietary libraries that do not normally accompany the operating system. Such a contradiction means you cannot use both them and the Library together in an executable that you distribute.

7. You may place library facilities that are a work based on the Library side-by-side in a single library together with other library facilities not covered by this License, and distribute such a combined library, provided that the separate distribution of the work based on the Library and of the other library facilities is otherwise permitted, and provided that you do these two things:
 - a) Accompany the combined library with a copy of the same work based on the Library, uncombined with any other library facilities. This must be distributed under the terms of the Sections above.
 - b) Give prominent notice with the combined library of the fact that part of it is a work based on the Library, and explaining where to find the accompanying uncombined form of the same work.
8. You may not copy, modify, sublicense, link with, or distribute the Library except as expressly provided under this License. Any attempt otherwise to copy, modify, sublicense, link with, or distribute the Library is void, and will automatically terminate your rights under this License. However, parties who have received copies, or rights, from you under this License will not have their licenses terminated so long as such parties remain in full compliance.
9. You are not required to accept this License, since you have not signed it. However, nothing else grants you permission to modify or distribute the Library or its derivative works. These actions are prohibited by law if you do not accept this License. Therefore, by modifying or distributing the Library (or any work based on the Library), you indicate your acceptance of this License to do so, and all its terms and conditions for copying, distributing or modifying the Library or works based on it.
10. Each time you redistribute the Library (or any work based on the Library), the recipient automatically receives a license from the original licensor to copy, distribute, link with or modify the Library subject to these terms and conditions. You may not impose any further restrictions on the recipients' exercise of the rights granted herein. You are not responsible for enforcing compliance by third parties with this License.
11. If, as a consequence of a court judgment or allegation of patent infringement or for any other reason (not limited to patent issues), conditions are imposed on you (whether by court order, agreement or otherwise) that contradict the conditions of this License, they do not excuse you from the conditions of this License. If you cannot distribute so as to satisfy simultaneously your obligations under this License and any other pertinent obligations, then as a consequence you may not distribute the Library at all. For example, if a patent license would not permit royalty-free redistribution of the Library by all those who receive copies directly or indirectly through you, then the only way you could satisfy both it and this License would be to refrain entirely from distribution of the Library.

If any portion of this section is held invalid or unenforceable under any particular circumstance, the balance of the section is intended to apply, and the section as a whole is intended to apply in other circumstances.

It is not the purpose of this section to induce you to infringe any patents or other property right claims or to contest validity of any such claims; this section has the sole purpose of protecting the integrity of the free software distribution system which is implemented by public license practices. Many people have made generous contributions to the wide range of software distributed through that system in reliance on consistent application of that system; it is up to the author/donor to decide if he or she is willing to distribute software through any other system and a licensee cannot impose that choice.

This section is intended to make thoroughly clear what is believed to be a consequence of the rest of this License.

12. If the distribution and/or use of the Library is restricted in certain countries either by patents or by copyrighted interfaces, the original copyright holder who places the Library under this License may add an explicit geographical distribution limitation excluding those countries, so that distribution is permitted only in or among countries not thus excluded. In such case, this License incorporates the limitation as if written in the body of this License.
13. The Free Software Foundation may publish revised and/or new versions of the Lesser General Public License from time to time. Such new versions will be similar in spirit to the present version, but may differ in detail to address new problems or concerns.

Each version is given a distinguishing version number. If the Library specifies a version number of this License which applies to it and "any later version", you have the option of following the terms and conditions either of that version or of any later version published by the Free Software Foundation. If the Library does not specify a license version number, you may choose any version ever published by the Free Software Foundation.

14. If you wish to incorporate parts of the Library into other free programs whose distribution conditions are incompatible with these, write to the author to ask for permission. For software which is copyrighted by the Free Software Foundation, write to the Free Software Foundation; we sometimes make exceptions for this. Our decision will be guided by the two goals of preserving the free status of all derivatives of our free software and of promoting the sharing and reuse of software generally.

NO WARRANTY

15. BECAUSE THE LIBRARY IS LICENSED FREE OF CHARGE, THERE IS NO WARRANTY FOR THE LIBRARY, TO THE EXTENT PERMITTED BY APPLICABLE LAW. EXCEPT WHEN OTHERWISE STATED IN WRITING THE COPYRIGHT HOLDERS AND/OR OTHER PARTIES PROVIDE THE LIBRARY "AS IS" WITHOUT WARRANTY OF ANY KIND, EITHER EXPRESSED OR IMPLIED, INCLUDING, BUT NOT LIMITED TO, THE IMPLIED WARRANTIES OF MERCHANTABILITY AND FITNESS FOR A PARTICULAR PURPOSE. THE ENTIRE RISK AS TO THE QUALITY AND PERFORMANCE OF THE LIBRARY IS WITH YOU. SHOULD THE LIBRARY PROVE DEFECTIVE, YOU ASSUME THE COST OF ALL NECESSARY SERVICING, REPAIR OR CORRECTION.
16. IN NO EVENT UNLESS REQUIRED BY APPLICABLE LAW OR AGREED TO IN WRITING WILL ANY COPYRIGHT HOLDER, OR ANY OTHER PARTY WHO MAY MODIFY AND/OR REDISTRIBUTE THE LIBRARY AS PERMITTED ABOVE, BE LIABLE TO YOU FOR DAMAGES, INCLUDING ANY GENERAL, SPECIAL, INCIDENTAL OR CONSEQUENTIAL DAMAGES ARISING OUT OF THE USE OR INABILITY TO USE THE LIBRARY (INCLUDING BUT NOT LIMITED TO LOSS OF DATA OR DATA BEING RENDERED INACCURATE OR LOSSES SUSTAINED BY YOU OR THIRD PARTIES OR A FAILURE OF THE LIBRARY TO OPERATE WITH ANY OTHER SOFTWARE), EVEN IF SUCH HOLDER OR OTHER PARTY HAS BEEN ADVISED OF THE POSSIBILITY OF SUCH DAMAGES.

END OF TERMS AND CONDITIONS

How to Apply These Terms to Your New Libraries

If you develop a new library, and you want it to be of the greatest possible use to the public, we recommend making it free software that everyone can redistribute and change. You can do so by permitting redistribution under these terms (or, alternatively, under the terms of the ordinary General Public License).

To apply these terms, attach the following notices to the library. It is safest to attach them to the start of each source file to most effectively convey the exclusion of warranty; and each file should have at least the "copyright" line and a pointer to where the full notice is found.

<one line to give the library's name and a brief idea of what it does.>

Copyright (C) <year> <name of author>

This library is free software; you can redistribute it and/or modify it under the terms of the GNU Lesser General Public License as published by the Free Software Foundation; either version 2.1 of the License, or (at your option) any later version.

This library is distributed in the hope that it will be useful, but WITHOUT ANY WARRANTY; without even the implied warranty of MERCHANTABILITY or FITNESS FOR A PARTICULAR PURPOSE. See the GNU Lesser General Public License for more details.

You should have received a copy of the GNU Lesser General Public License along with this library; if not, write to the Free Software Foundation, Inc., 51 Franklin Street, Fifth Floor, Boston, MA 02110-1301 USA

Also add information on how to contact you by electronic and paper mail.

You should also get your employer (if you work as a programmer) or your school, if any, to sign a "copyright disclaimer" for the library, if necessary. Here is a sample; alter the names:

Yoyodyne, Inc., hereby disclaims all copyright interest in the library `Frob' (a library for tweaking knobs) written by James Random Hacker.

<signature of Ty Coon>, 1 April 1990

Ty Coon, President of Vice

That's all there is to it!

BSD License (Berkeley Software Distribution License)

This projector product includes the open source software program "University of California, Berkeley License (Berkeley Software Distribution License)" which applies the terms and conditions provided by owner of the copyright to the "BSD License".

The "BSD License" are WITHOUT ANY WARRANTY; without even the implied warranty of MERCHANTABILITY AND FITNESS FOR A PARTICULAR PURPOSE.

List of BSD License programs

busybox_1.7.2

License terms of conditions of each program which are provided by owner of the copyright to the "BSD License" are as follows.

Copyright (c) The Regents of the University of California. All rights reserved.

This code is derived from software contributed to Berkeley by Kenneth Almquist.

Redistribution and use in source and binary forms, with or without modification, are permitted provided that the following conditions are met:

1. Redistributions of source code must retain the above copyright notice, this list of conditions and the following disclaimer.
2. Redistributions in binary form must reproduce the above copyright notice, this list of conditions and the following disclaimer in the documentation and/or other materials provided with the distribution.
3. Neither the name of the University nor the names of its contributors may be used to endorse or promote products derived from this software without specific prior written permission.

THIS SOFTWARE IS PROVIDED BY THE REGENTS AND CONTRIBUTORS "AS IS" AND ANY EXPRESS OR IMPLIED WARRANTIES, INCLUDING, BUT NOT LIMITED TO, THE IMPLIED WARRANTIES OF MERCHANTABILITY AND FITNESS FOR A PARTICULAR PURPOSE ARE DISCLAIMED. IN NO EVENT SHALL THE REGENTS OR CONTRIBUTORS BE LIABLE FOR ANY DIRECT, INDIRECT, INCIDENTAL, SPECIAL, EXEMPLARY, OR CONSEQUENTIAL DAMAGES (INCLUDING, BUT NOT LIMITED TO, PROCUREMENT OF SUBSTITUTE GOODS OR SERVICES; LOSS OF USE, DATA, OR PROFITS; OR BUSINESS INTERRUPTION) HOWEVER CAUSED AND ON ANY THEORY OF LIABILITY, WHETHER IN CONTRACT, STRICT LIABILITY, OR TORT (INCLUDING NEGLIGENCE OR OTHERWISE) ARISING IN ANY WAY OUT OF THE USE OF THIS SOFTWARE, EVEN IF ADVISED OF THE POSSIBILITY OF SUCH DAMAGE.

libjpeg

This projector product includes the open source software program "libjpeg" which applies the terms and conditions provided by owner of the copyright to the "libjpeg".

The "libjpeg" are WITHOUT ANY WARRANTY; without even the implied warranty of MERCHANTABILITY AND FITNESS FOR A PARTICULAR PURPOSE.

List of libjpeg programs

libjpeg-6b

License terms of conditions of each program which are provided by owner of the copyright to the "libjpeg" are as follows.

Copyright (C) 1994-1997, Thomas G. Lane. This file is part of the Independent JPEG Group's software. For conditions of distribution and use, see the accompanying README file.

This distribution contains the sixth public release of the Independent JPEG Group's free JPEG software. You are welcome to redistribute this software and to use it for any purpose, subject to the conditions under LEGAL ISSUES, below.

LEGAL ISSUES

=====

In plain English:

1. We don't promise that this software works. (But if you find any bugs, please let us know!)
2. You can use this software for whatever you want. You don't have to pay us.
3. You may not pretend that you wrote this software. If you use it in a program, you must acknowledge somewhere in your documentation that you've used the IJG code.

In legalese:

The authors make NO WARRANTY or representation, either express or implied, with respect to this software, its quality, accuracy, merchantability, or fitness for a particular purpose. This software is provided "AS IS", and you, its user, assume the entire risk as to its quality and accuracy.

This software is copyright (C) 1991-1998, Thomas G. Lane. All Rights Reserved except as specified below.

Permission is hereby granted to use, copy, modify, and distribute this software (or portions thereof) for any purpose, without fee, subject to these conditions:

- (1) If any part of the source code for this software is distributed, then this README file must be included, with this copyright and no-warranty notice unaltered; and any additions, deletions, or changes to the original files must be clearly indicated in accompanying documentation.
- (2) If only executable code is distributed, then the accompanying documentation must state that "this software is based in part on the work of the Independent JPEG Group".
- (3) Permission for use of this software is granted only if the user accepts full responsibility for any undesirable consequences; the authors accept NO LIABILITY for damages of any kind.

These conditions apply to any software derived from or based on the IJG code, not just to the unmodified library. If you use our work, you ought to acknowledge us.

Permission is NOT granted for the use of any IJG author's name or company name in advertising or publicity relating to this software or products derived from it. This software may be referred to only as "the Independent JPEG Group's software".

We specifically permit and encourage the use of this software as the basis of commercial products, provided that all warranty or liability claims are assumed by the product vendor.

ansi2knr.c is included in this distribution by permission of L. Peter Deutsch, sole proprietor of its copyright holder, Aladdin Enterprises of Menlo Park, CA. ansi2knr.c is NOT covered by the above copyright and conditions, but instead by the usual distribution terms of the Free Software Foundation; principally, that you must include source code if you redistribute it. (See the file ansi2knr.c for full details.) However, since ansi2knr.c is not needed as part of any program generated from the IJG code, this does not limit you more than the foregoing paragraphs do.

The Unix configuration script "configure" was produced with GNU Autoconf. It is copyright by the Free Software Foundation but is freely distributable. The same holds for its supporting scripts (config.guess, config.sub, ltconfig, ltmain.sh). Another support script, install-sh, is copyright by M.I.T. but is also freely distributable.

It appears that the arithmetic coding option of the JPEG spec is covered by patents owned by IBM, AT&T, and Mitsubishi. Hence arithmetic coding cannot legally be used without obtaining one or more licenses. For this reason, support for arithmetic coding has been removed from the free JPEG software. (Since arithmetic coding provides only a marginal gain over the unpatented Huffman mode, it is unlikely that very many implementations will support it.) So far as we are aware, there are no patent restrictions on the remaining code.

The IJG distribution formerly included code to read and write GIF files. To avoid entanglement with the Unisys LZW patent, GIF reading support has been removed altogether, and the GIF writer has been simplified to produce "uncompressed GIFs". This technique does not use the LZW algorithm; the resulting GIF files are larger than usual, but are readable by all standard GIF decoders.

We are required to state that

"The Graphics Interchange Format(c) is the Copyright property of CompuServe Incorporated. GIF(sm) is a Service Mark property of CompuServe Incorporated."

libpng

This projector product includes the open source software program "libpng" which applies the terms and conditions provided by owner of the copyright to the "libpng".

The "libpng" are WITHOUT ANY WARRANTY; without even the implied warranty of MERCHANTABILITY AND FITNESS FOR A PARTICULAR PURPOSE.

List of libpng programs

libpng-1.2.7

License terms of conditions of each program which are provided by owner of the copyright to the "libpng" are as follows.

For conditions of distribution and use, see copyright notice in png.h Copyright (c) 1998-2004 Glenn Randers-Pehrson (Version 0.96 Copyright (c) 1996, 1997 Andreas Dilger) (Version 0.88 Copyright (c) 1995, 1996 Guy Eric Schalnat, Group 42, Inc.)

This copy of the libpng notices is provided for your convenience. In case of any discrepancy between this copy and the notices in the file png.h that is included in the libpng distribution, the latter shall prevail.

COPYRIGHT NOTICE, DISCLAIMER, and LICENSE:

If you modify libpng you may insert additional notices immediately following this sentence.

libpng version 1.2.6, September 12, 2004, is Copyright (c) 2004 Glenn Randers-Pehrson, and is distributed according to the same disclaimer and license as libpng-1.2.5 with the following individual added to the list of Contributing Authors

Cosmin Truta

libpng versions 1.0.7, July 1, 2000, through 1.2.5 - October 3, 2002, are Copyright (c) 2000-2002 Glenn Randers-Pehrson, and are distributed according to the same disclaimer and license as libpng-1.0.6 with the following individuals added to the list of Contributing Authors

Simon-Pierre Cadieux

Eric S. Raymond

Gilles Vollant

and with the following additions to the disclaimer:

There is no warranty against interference with your enjoyment of the library or against infringement. There is no warranty that our efforts or the library will fulfill any of your particular purposes or needs. This library is provided with all faults, and the entire risk of satisfactory quality, performance, accuracy, and effort is with the user.

libpng versions 0.97, January 1998, through 1.0.6, March 20, 2000, are Copyright (c) 1998, 1999 Glenn Randers-Pehrson, and are distributed according to the same disclaimer and license as libpng-0.96, with the following individuals added to the list of Contributing Authors:

Tom Lane
Glenn Randers-Pehrson
Willem van Schaik

libpng versions 0.89, June 1996, through 0.96, May 1997, are Copyright (c) 1996, 1997 Andreas Dilger Distributed according to the same disclaimer and license as libpng-0.88, with the following individuals added to the list of Contributing Authors:

John Bowler
Kevin BraceySam Bushell
Sam Bushell
Magnus Holmgren
Greg Roelofs
Tom Tanner

libpng versions 0.5, May 1995, through 0.88, January 1996, are Copyright (c) 1995, 1996 Guy Eric Schalnat, Group 42, Inc.

For the purposes of this copyright and license, "Contributing Authors" is defined as the following set of individuals:

Andreas Dilger
Dave Martindale
Guy Eric Schalnat
Paul Schmidt
Tim Wegner

The PNG Reference Library is supplied "AS IS". The Contributing Authors and Group 42, Inc. disclaim all warranties, expressed or implied, including, without limitation, the warranties of merchantability and of fitness for any purpose. The Contributing Authors and Group 42, Inc. assume no liability for direct, indirect, incidental, special, exemplary, or consequential damages, which may result from the use of the PNG Reference Library, even if advised of the possibility of such damage.

Permission is hereby granted to use, copy, modify, and distribute this source code, or portions hereof, for any purpose, without fee, subject to the following restrictions:

1. The origin of this source code must not be misrepresented.
2. Altered versions must be plainly marked as such and must not be misrepresented as being the original source.
3. This Copyright notice may not be removed or altered from any source or altered source distribution.

The Contributing Authors and Group 42, Inc. specifically permit, without fee, and encourage the use of this source code as a component to supporting the PNG file format in commercial products. If you use this source code in a product, acknowledgment is not required but would be appreciated.

A "png_get_copyright" function is available, for convenient use in "about" boxes and the like:

```
printf("%s",png_get_copyright(NULL));
```

Also, the PNG logo (in PNG format, of course) is supplied in the files "pngbar.png" and "pngbar.jpg (88x31) and "pngnow.png" (98x31).

Libpng is OSI Certified Open Source Software. OSI Certified Open Source is a certification mark of the Open Source Initiative.

Glenn Randers-Pehrson
glennrp@users.sourceforge.net
September 12, 2004

zlib

This projector product includes the open source software program "zlib" which applies the terms and conditions provided by owner of the copyright to the "zlib".

The "zlib" are WITHOUT ANY WARRANTY; without even the implied warranty of MERCHANTABILITY AND FITNESS FOR A PARTICULAR PURPOSE.

List of zlib programs

zlib-1.1.4

License terms of conditions of each program which are provided by owner of the copyright to the "zlib" are as follows.

Copyright notice:

(C) 1995-1998 Jean-loup Gailly and Mark Adler

This software is provided 'as-is', without any express or implied warranty. In no event will the authors be held liable for any damages arising from the use of this software.

Permission is granted to anyone to use this software for any purpose, including commercial applications, and to alter it and redistribute it freely, subject to the following restrictions:

1. The origin of this software must not be misrepresented; you must not claim that you wrote the original software. If you use this software in a product, an acknowledgment in the product documentation would be appreciated but is not required.
2. Altered source versions must be plainly marked as such, and must not be misrepresented as being the original software.
3. This notice may not be removed or altered from any source distribution.

Jean-loup Gailly
jloup@gzip.org

Mark Adler
madler@alumni.caltech.edu

If you use the zlib library in a product, we would appreciate *not* receiving lengthy legal documents to sign. The sources are provided for free but without warranty of any kind. The library has been entirely written by Jean-loup Gailly and Mark Adler; it does not include third-party code.

If you redistribute modified sources, we would appreciate that you include in the file ChangeLog history information documenting your changes.

libmd5-rfc

This project product includes the open source software program "libmd5-rfc" which applies the terms and conditions provided by owner of the copyright to the "libmd5-rfc".

The "libmd5-rfc" are WITHOUT ANY WARRANTY; without even the implied warranty of MERCHANTABILITY AND FITNESS FOR A PARTICULAR PURPOSE.

List of libmd5-rfc programs

libmd5-rfc

License terms of conditions of each program which are provided by owner of the copyright to the "libmd5-rfc" are as follows.

Copyright (C) 1999, 2002 Aladdin Enterprises. All rights reserved.

This software is provided 'as-is', without any express or implied warranty. In no event will the authors be held liable for any damages arising from the use of this software.

Permission is granted to anyone to use this software for any purpose, including commercial applications, and to alter it and redistribute it freely, subject to the following restrictions:

1. The origin of this software must not be misrepresented; you must not claim that you wrote the original software. If you use this software in a product, an acknowledgment in the product documentation would be appreciated but is not required.
2. Altered source versions must be plainly marked as such, and must not be misrepresented as being the original software.
3. This notice may not be removed or altered from any source distribution.

L. Peter Deutsch ghost@aladdin.com

Independent implementation of MD5 (RFC 1321).

This code implements the MD5 Algorithm defined in RFC 1321, whose text is available at

<http://www.ietf.org/rfc/rfc1321.txt>

The code is derived from the text of the RFC, including the test suite (section A.5) but excluding the rest of Appendix A. It does not include any code or documentation that is identified in the RFC as being copyrighted.

The original and principal author of md5.h is L. Peter Deutsch <ghost@aladdin.com>. Other authors are noted in the change history that follows (in reverse chronological order):

- 2002-04-13 lpd Removed support for non-ANSI compilers; removed references to Ghostscript; clarified derivation from RFC 1321; now handles byte order either statically or dynamically.
- 1999-11-04 lpd Edited comments slightly for automatic TOC extraction.
- 1999-10-18 lpd Fixed typo in header comment (ansi2knr rather than md5); added conditionalization for C++ compilation from Martin Purschke<purschke@bnl.gov>.
- 1999-05-03 lpd Original version.

ncurses

This projector product includes the open source software program "ncurses" which applies the terms and conditions provided by owner of the copyright to the "ncurses".

The "ncurses" are WITHOUT ANY WARRANTY; without even the implied warranty of MERCHANTABILITY AND FITNESS FOR A PARTICULAR PURPOSE.

List of ncurses programs

ncurses-5.6

License terms of conditions of each program which are provided by owner of the copyright to the "ncurses" are as follows.

Copyright (c) 1998-2002,2003 Free Software Foundation, Inc.

Permission is hereby granted, free of charge, to any person obtaining a copy of this software and associated documentation files (the "Software"), to deal in the Software without restriction, including without limitation the rights to use, copy, modify, merge, publish, distribute, distribute with modifications, sublicense, and/or sell copies of the Software, and to permit persons to whom the Software is furnished to do so, subject to the following conditions:

The above copyright notice and this permission notice shall be included in all copies or substantial portions of the Software.

THE SOFTWARE IS PROVIDED "AS IS", WITHOUT WARRANTY OF ANY KIND, EXPRESS OR IMPLIED, INCLUDING BUT NOT LIMITED TO THE WARRANTIES OF MERCHANTABILITY, FITNESS FOR A PARTICULAR PURPOSE AND NONINFRINGEMENT. IN NO EVENT SHALL THE ABOVE COPYRIGHT HOLDERS BE LIABLE FOR ANY CLAIM, DAMAGES OR OTHER LIABILITY, WHETHER IN AN ACTION OF CONTRACT, TORT OR OTHERWISE, ARISING FROM, OUT OF OR IN CONNECTION WITH THE SOFTWARE OR THE USE OR OTHER DEALINGS IN THE SOFTWARE.

Except as contained in this notice, the name(s) of the above copyright holders shall not be used in advertising or otherwise to promote the sale, use or other dealings in this Software without prior written authorization.

For embedded multimedia software:

This product contains embedded multimedia software licensed from Ingenient Technologies, Inc. (www.ingenient.com).

Copyright© 2000-2007 Ingenient Technologies, Inc. All rights reserved.

For MPEG-4 ASP:

With respect to a Licensee offering MPEG-4 Video Decoders and/or Encoders the following notice shall be given: THIS PRODUCT IS LICENSED UNDER THE MPEG-4 VISUAL PATENT PORTFOLIO LICENSE FOR THE PERSONAL AND NONCOMMERCIAL USE OF A CONSUMER FOR (i) ENCODING VIDEO IN COMPLIANCE WITH THE MPEG-4 VISUAL STANDARD ("MPEG-4 VIDEO") AND/OR (ii) DECODING MPEG-4 VIDEO THAT WAS ENCODED BY A CONSUMER ENGAGED IN A PERSONAL AND NON-COMMERCIAL ACTIVITY AND/OR WAS OBTAINED FROM A VIDEO PROVIDER LICENSED BY MPEG LA TO PROVIDE MPEG-4 VIDEO. NO LICENSE IS GRANTED OR SHALL BE IMPLIED FOR ANY OTHER USE. ADDITIONAL INFORMATION INCLUDING THAT RELATING TO PROMOTIONAL, INTERNAL AND COMMERCIAL USES AND LICENSING MAY BE OBTAINED FROM MPEG LA,LLC. SEE [HTTP://WWW.MPEGLA.COM](http://WWW.MPEGLA.COM).

For MPEG-4 AVC:

THIS PRODUCT IS LICENSED UNDER THE AVC PATENT PORTFOLIO LICENSE FOR THE PERSONAL AND NON-COMMERCIAL USE OF A CONSUMER TO (i) ENCODE VIDEO IN COMPLIANCE WITH THE AVC STANDARD ("AVC VIDEO") AND/OR (ii) DECODE AVC VIDEO THAT WAS ENCODED BY A CONSUMER ENGAGED IN A PERSONAL AND NON-COMMERCIAL ACTIVITY AND/OR WAS OBTAINED FROM A VIDEO PROVIDER LICENSED TO PROVIDE AVC VIDEO. NO LICENSE IS GRANTED OR SHALL BE IMPLIED FOR ANY OTHER USE. ADDITIONAL INFORMATION MAY BE OBTAINED FROM MPEG LA, L.L.C. SEE [HTTP://WWW.MPEGLA.COM](http://WWW.MPEGLA.COM)

For WMV/WMA (Microsoft):

This product is protected by certain intellectual property rights of Microsoft.

Use or distribution of such technology outside of this product is prohibited without a license from Microsoft.

Index

A

- A/V Mute
 - button, 67
 - display settings, 125
- Access Point mode, 82
- Accessories, 15 to 16
- Ad Hoc mode, 81
- Air filter
 - cleaning, 134 to 137
 - ordering, 15
 - replacing, 137 to 138
- Altitude, 127, 148, 149, 174
- Anti-theft device, 15, 30, 164 to 165
- Aspect ratio, 170
- Audio
 - connecting equipment, 46 to 49
 - controlling volume, 68
 - problems, troubleshooting, 156 to 157
 - turning off (using A/V Mute), 67
- Audio Input setting, 120
- Authentication, 94 to 95
- Auto Setup setting, 116

B

- Background screen settings, 125
- Bands, vertical, 155
- Blank screen, 150 to 152
- Blurry image, 154 to 155
- Brightness, 169
- Brightness setting, 114
- Browser control, 101

C

- Cable cover, 166

Cables

- BNC to VGA, 35
 - component, 15, 36, 42
 - composite, 36, 40
 - DVI/HDMI conversion, 32, 39
 - DVI-D, 31, 38
 - Ethernet, 76
 - HDMI, 33, 37
 - illustrations, 18
 - network, 76
 - ordering, 15 to 16
 - remote control cable set, 15
 - security, 164
 - S-Video, 41
 - VGA, 34, 43
- ## Capturing image, 123 to 124
- ## Ceiling mount, 15, 163 to 164
- ## Certificate validation, 95 to 96
- ## Cleaning
- air filter, 134 to 137
 - lens, 134
 - projector case, 134
- ## Closed captions, 126
- ## Color
- correcting, 60, 114 to 116
 - multi-screen adjustment, 128
 - problems, 156
 - saturation, 114
 - settings, 114 to 115
 - temperature, 115
- ## Color Mode, 60 to 61, 114
- ## Component video cable, 15, 36, 42
- ## Composite video cable, 36, 40
- ## Computer
- connecting to, 30 to 35
 - selecting source, 56

- Connecting projector
 - to audio equipment, 46 to 49
 - to computer, 30 to 35
 - to digital camera, 50 to 51
 - to external monitor, 45
 - to speakers, 49
 - to video equipment, 36 to 44
- Contrast setting, 114
- Control Panel Lock setting, 119, 125
- Crestron RoomView, 104
- Custom screen, *see* User's Logo
- Customized color mode, 61

D

- Data encryption, 96
- Default settings, restoring, 113
- DICOM SIM color mode, 61
- Digital camera
 - connecting to, 50 to 51
- Direct Power On, 53
- Distance from projector to screen, 19, 170
- Documentation, 13 to 14
- DVD player, connecting, 36 to 44
- DVI/HDMI conversion cable, 32, 39
- DVI-D cable, 31, 38
- Dynamic color mode, 60

E

- EAP authentication, 94 to 95
- EAP-TLS certificate, 95 to 96
- EasyMP Monitor
 - features, 75
 - problems, 158
- EasyMP Multi PC Projection
 - features, 75
 - problems, 158
- EasyMP Network Projection
 - creating password for, 81
 - features, 96
 - problems, 158
- Electrical specifications, 172
- E-mail alerts, 98 to 100
- Encryption, 91 to 92, 96
- Environmental specifications, 173

- Epson
 - accessories, 15 to 16
 - PrivateLine Support, 14
 - technical support, 14, 161 to 162
 - warranty, 14
- Ethernet connection, 76 to 77
- Extended menu, 126 to 128
- External monitor, connecting, 45
- E-Zoom button, 68

F

- FCC compliance statement, 183
- Filter, *see* Air filter
- Focusing image, 58
- Freeze button, 67

H

- HDMI cable, 33, 37
- HDTV images, video formats, 176, 177
- Height of image, adjusting, 57 to 58
- Help, 13 to 14, 161 to 162
- Help system, using, 146
- High altitude, 127, 148, 149

I

- Image
 - adjusting, 56 to 62, 114 to 116
 - blurry, 154 to 155
 - capturing and saving in projector,
 - 123 to 124
 - correcting shape, 58 to 60, 119, 153
 - fitting on screen, 116, 153
 - height, adjusting, 57 to 58
 - problems with, 150 to 156
 - raising, 57 to 58
 - selecting source, 56, 66
 - shape, correcting, 58 to 60
 - size and projection distance, 19, 170
 - turning off (using A/V Mute), 67
 - turning off temporarily, 67
 - zooming, 58, 68
- Image menu, 114 to 115
- Info menu, 142

Infrastructure mode, *see* Access Point mode
Input Signal setting, 118
Input signal, selecting, 56, 66
Installing
 cable cover, 166
 projector, 163 to 164
Instant Off, 54

K

Kensington anti-theft device, 15, 30, 164
Keystone correction, 58 to 60, 119, 153, 171
Keyword, 81

L

Lamp
 number of hours used, 142
 ordering, 15
 replacing, 138 to 142
 specifications, 171
 status light, 147 to 149
Lamp timer, resetting, 141 to 142
Language setting, 128
Laptop computer
 connecting to, 34 to 35
 display problems, 150 to 153
 selecting source, 56, 66
LEAP authentication, 94 to 95
Lens theft deterrent screw, 165
Lens, cleaning, 134
Lights, status, 147 to 149
Logo, saving on projector, 123 to 125

M

Macintosh
 display problems, 151
 selecting network settings, 85
Manuals, 13 to 14

Menus
 changing settings, 112 to 113
 default settings, restoring, 113
 Extended, 126 to 128
 Image, 114 to 115
 Info, 142
 Network, 80
 network, 76, 91, 93, 94, 95, 98
 Settings, 119 to 120
 Signal, 116 to 118
 User's Logo, 123 to 124
Monitor, connecting, 45
Monitoring projector
 EasyMP Monitor, 75
 e-mail notifications, 98 to 100
 SNMP, 100 to 101
 using browser, 101
Mouse
 compatibility, 171
 using remote control as, 70
Multiple projectors, controlling, 71 to 73
Multi-screen color adjustment, 128

N

Network
 cable, 76
 managing projector remotely, 98 to 109
 problems, 157 to 158
 settings, 76 to 101
 wired, 76 to 77
 wireless, 75 to 98
Network settings, configuring, 75 to 109
No Signal message, 150 to 151
Noise level, 170
Noise Reduction setting, 117
Not Supported message, 152
Numeric keypad, using, 122

O

Optical aspect ratio, 170
Options for projector, 15 to 16

P

Password

- protection, 121 to 123
- remote access, 81
- request code, 123

PEAP authentication, 94 to 95

Photo color mode, 60

Picture source, selecting, 56, 66

Picture, *see* Image

PIN code method, 85, 88 to 90

Pointer shape, 119

Pointer tool, using, 69

Positioning

- image, 57 to 58
- projector, 19 to 30, 163 to 164

Power

- button, 53
- specifications, 172
- status light, 53, 147 to 149

Power consumption, 119

Presentation color mode, 60

Presentations

- computer, 30 to 35
- digital camera, 50 to 51
- room conditions, 19, 66
- using the pointer tool, 69
- video, 36 to 44
- wireless, 75 to 98

PrivateLine Support, 14

Problems

- color, 156
- image, 150 to 156
- monitoring projector, 157 to 158
- no signal, 150 to 151
- remote control, 160
- sound, 156 to 157
- using on-screen help, 146

Progressive format, 117

Projecting without screen, 60

Projection lamp, *see* Lamp

Projector

- cleaning, 134
- disabling buttons, 125
- distance from screen, 19, 170
- installing, 163 to 164
- lamp specifications, 171
- Menu and Options List, 129 to 131
- monitoring remotely, 98 to 109
- options, 15 to 16
- password protection, 121 to 123
- positioning, 19 to 30, 163 to 164
- resolution, 169
- security features, 121 to 125, 164 to 165
- specifications, 169 to 174
- transporting, 143
- troubleshooting, 145 to 162
- turning off, 54
- turning on, 51 to 53
- unpacking, 18
- viewing information about, 142

Projector ID

- checking, 72
- setting, 71

Push button method, 85, 87 to 88

Q

Quick Corner, 58, 119

Quick Wireless Connection, using, 79

R

Raising image, 57 to 58

Rear-screen projection, 126, 163 to 164

Registration, 14

Remote control
A/V Mute button, 67
as wireless mouse, 70
battery used, 171
controlling multiple projectors, 71 to 73
correcting color, 60, 114 to 116
E-Zoom button, 68
Freeze button, 67
ID, 72 to 73
numeric keypad, using, 122
pointer tool, using, 69
problems, 160
range, 171
specifications, 171
switching sources, 66
troubleshooting, 160
virtual over network, 102

Remote Receiver setting, 120

Removing wireless module, 97

Replacing lamp, 138 to 142

Request code, password, 123

Resetting lamp timer, 141 to 142

Resetting menu options, 113

Resize image, 61 to 62

Resolution, 61 to 62, 152, 169

Resolution setting, 117

S

Safety
instructions, 179 to 182
specifications, 174

Saturation setting, 114

Screen
blank, 150 to 152
distance from projector, 19, 170
ordering, 15
startup screen, creating, 123 to 124

Screen image, *see* Image

Security
cables, 164
Control Panel Lock, 125
identifying logo, 123 to 125
Kensington lock, 15, 164
password protection, 121 to 123

Settings menu, 119 to 120

Sharpness setting, 115

Signal menu, 116 to 118

Six-axis color adjustment, 115 to 116

Sleep mode, 51, 127

SNMP, 100 to 101

Sound, troubleshooting, 156

Source, selecting, 56, 66

Speaker, specifications, 170

Speakers, connecting, 49

Specifications
brightness, 169
dimensions, 171
electrical, 172
environmental, 173
general, 169
lamp, 171
remote control, 171
resolution, 169
safety, 174
speaker, 170

Split screen, 62, 119

Sports color mode, 60

sRGB color mode, 61

SSID, 83, 84, 85

Startup screen
creating, 123 to 125
settings, 125
user's logo, *see* User's Logo

Status lights, 147 to 149

Support, *see* Technical support

S-Video cable, 41

Switching picture source, 56, 66

Sync setting, 117

Synchronization, adjusting, 155

T

Technical support, 14, 161 to 162

Temperature
requirements, 173
status light, 147 to 149

Temperature, color, 115

Test pattern, displaying, 120

Theatre color mode, 60

- Tint setting, 114
- Tracking, adjusting, 155
- Transporting projector, 143
- Troubleshooting
 - blank screen, 150 to 152
 - cut-off image, 153
 - distorted image, 58 to 60
 - EasyMP Monitor problems, 158
 - EasyMP Multi PC Projection problems, 158
 - EasyMP Network Projection problems, 158
 - image and sound problems, 150 to 157
 - network problems, 157 to 158
 - no signal, 150 to 151
 - projector problems, 145 to 162
 - remote control problems, 160
 - tapered image, 58 to 60
- Turning off picture (using A/V Mute), 67
- Turning off projector, 54

U

- Unpacking projector, 18
- USB key, 79
- User's Logo
 - creating, 123 to 124
 - display settings, 124 to 125

V

- VGA video cable, 34, 43
- Video
 - cables, 15 to 16, 18, 36
 - connecting video equipment, 36 to 44
 - formats, supported, 174 to 177
 - selecting source, 56, 66
- Video Signal setting, 118
- Volume, controlling, 68, 120

W

- Warning lights, 147 to 149
- Warranty, 14
- Web browser control, 101
- Web Remote Control, 102
- WEP encryption, 91 to 92

- Wi-Fi, 85 to 90
- Windows
 - display problems, 151
 - selecting network settings, 84
- Wired network, 76 to 77
- Wireless
 - EAP, 94 to 95
 - EAP-TLS, 95 to 96
 - LEAP, 94 to 95
 - module, 15, 78 to 79, 97
 - PEAP, 94 to 95
 - presentation, 75 to 98
 - Quick Wireless Connection, 79
 - WEP encryption, 91 to 92
 - WPA security, 93
- Wireless, mouse, 70
- WPA security, 93
- WPS connection, 85 to 90

Z

- Zoom ratio, 170
- Zooming image, 58, 68

EPSON[®]
EXCEED YOUR VISION