



EPXi Series



EPXi Series

CLARK
THE FORKLIFT



Load capacity:
max. 3.200 kg



Lift height:
max. 7315 mm



Travel speed:
max. 18 km/h



Stacking aisle width:
min. 3808 mm



Battery capacity:
max. 48 V/ 715 Ah



Drive motor rating:
15 kW

Wet, uneven floors and restricted working environments are no problem for the new EPXi electric forklift, making it the perfect alternative to an IC Forklift.

The new EPXi series CLARK forklift is a quiet non-polluting operation alternative to internal combustion engine trucks. The robust electric counterbalanced EPXi is suitable for most applications with handling capacities from 2.0 to 3.2 tonnes.

A solid 'Built to Last' construction with a well designed driver compartment makes the CLARK EPXi series the truck you need to operate in a smart and safe manner over long periods.

The new CLARK EPXi is available now with long term rental rates similar to an equivalent IC truck!

CLARK International South Pacific
30 Salisbury Road
Hornsby, NSW 2077 Australia
Tel: 1800 005 747
Website: www.clarkforklifts.com.au

DIMENSIONS

EPX20i/22i/25i/30i/32i*

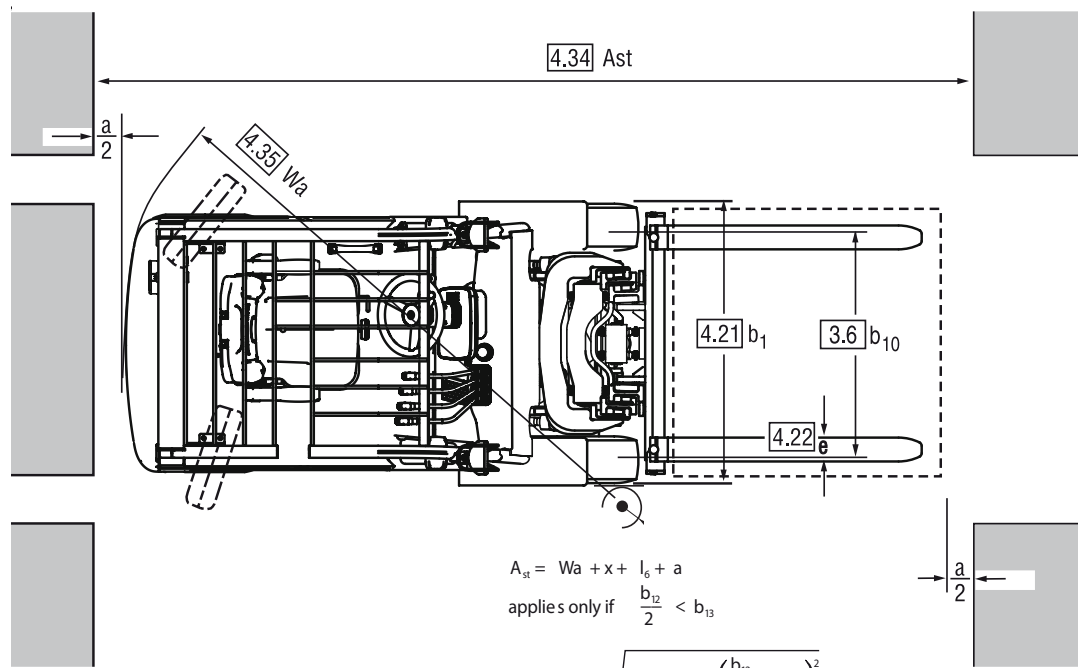
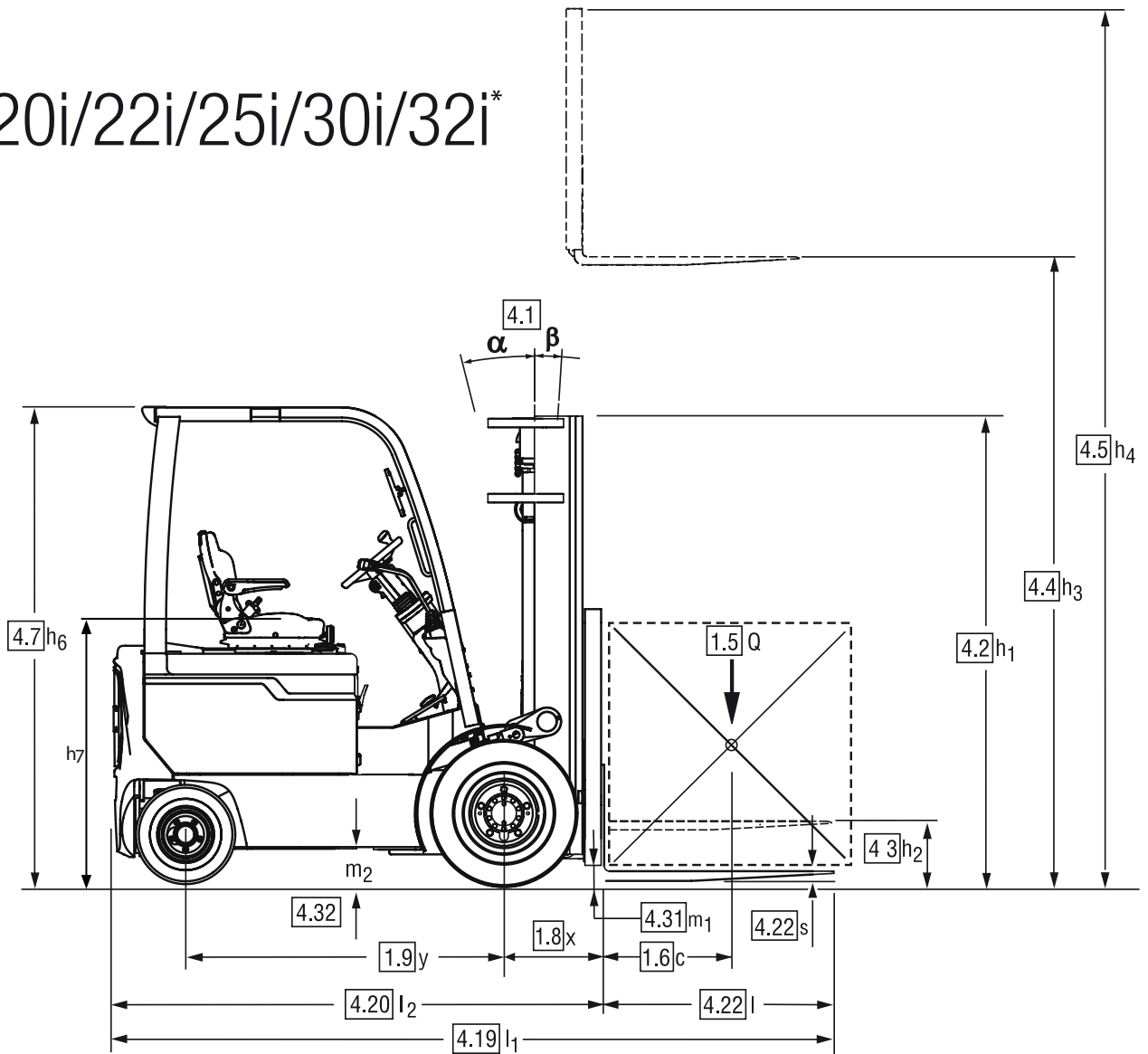

$$A_{st} = W_a + x + l_6 + a$$

applies only if $\frac{b_{12}}{2} < b_{13}$

$$A_{st} = W_a + \sqrt{l_6 + x)^2 + \left(\frac{b_{12}}{2} - b_{13}\right)^2} + a$$

applies only if $\frac{b_{12}}{2} \geq b_{13}$

$$a = 200$$

For corresponding data see Specification Chart.

SPECIFICATIONS

Product Specifications acc. to VDI 2198

1.1 Manufacturer (Abbreviation)		CLARK	CLARK	CLARK	
Specifications	1.2 Manufacturer's designation	EPX20i	EPX22i	EPX25i	
	1.3 Drive unit	Electro-48V	Electro-48V	Electro-48V	
	1.4 Operator type stand on/driver seated	Rider-seated	Rider-seated	Rider-seated	
	1.5 Load capacity/rated load	Q (kg)	2000	2200	2500
	1.6 Load centre distance	c (mm)	500	500	500
	1.8 Load centre distance, centre of drive axle to fork face	x (mm)	465	465	465
	1.9 Wheelbase	y (mm)	1475	1475	1475
Weight	2.1 Service weight	kg	3770	3830	4120
	2.2 Axle loading, laden front/rear	kg	5013 / 757	5239 / 791	5750 / 870
	2.3 Axle loading, unladen front/rear	kg	1568 / 2202	1593 / 2237	1714 / 2406
Tyres, Chassis	3.1 Tyre type, SE = superelastic		SE	SE	SE
	3.2 Tyre size, front, superelastic		7.0 x 12	7.0 x 12	7.0 x 12
	3.3 Tyre size, rear, superelastic		18 x 7 x 8	18 x 7 x 8	18 x 7 x 8
	3.5 Wheels, number front/rear (x = drive wheels)		2 x / 2	2 x / 2	2 x / 2
	3.6 Tread, front	b10 (mm)	998	998	998
	3.7 Tread, rear	b11 (mm)	915	915	915
	Dimensions	4.1 Tilt of upright/fork carriage	a/b deg	10 / 6	10 / 6
4.2 Height, upright lowered		h1 (mm)	2165	2165	2165
4.3 Freelift		h2 (mm)	110	110	110
4.4 Lift height *1		h3 (mm)	3300	3300	3300
4.5 Height, upright extended (with load backrest)		h4 (mm)	4520	4520	4520
4.7 Height overheadguard		h6 (mm)	2195	2195	2195
4.8 Seat height		h7 (mm)	1240	1240	1240
4.19 Overall length		l1 (mm)	3340	3340	3399
4.20 Length to face of forks		l2 (mm)	2273	2273	2332
4.21 Width		b1 (mm)	1195	1195	1195
4.22 Fork dimensions		s*e*l (mm)	45 x 100 x 1070	45 x 100 x 1070	45 x 100 x 1070
4.23 Fork carriage DIN 15173, A, B			Class II A	Class II A	Class II A
4.24 Fork carriage width		b3 (mm)	1040	1040	1040
4.31 Ground clearance minimum, laden		m1 (mm)	135	135	135
4.32 Ground clearance centre of wheelbase		m2 (mm)	135	135	135
4.34 Stacking aisle for pallets (l6 • b12) 1000x1200 across		Ast (mm)	3808	3808	3854
4.34 Stacking aisle for pallets (l6 • b12) 800x1200 along	Ast (mm)	4008	4008	4054	
4.35 Turning radius	Wa (mm)	2143	2143	2189	
4.36 Internal Turning radius	b13 (mm)	610	610	610	
Performance	5.1 Travel speed laden/unladen	km/h	18 / 18	18 / 18	16 / 18
	5.2 Lift speed laden/unladen	m/s	0.38 / 0.48	0.37 / 0.48	0.36 / 0.48
	5.3 Lowering speed laden/unladen	m/s	0.55 / 0.50	0.55 / 0.50	0.55 / 0.50
	5.6 Max. drawbar pull laden/unladen (S2 5 min) *2	N	1445 / 880	1444 / 916	1680 / 970
	5.8 max. gradeability laden/unladen (S2 5 min) *2	%	25.7 / 22.8	24.1 / 22.8	21.8 / 19.5
	5.10 Service brake		Drum	Drum	Drum
Drive line	6.1 Drive motor rating (S2 60 min)	kW	15	15	15
	6.2 Lift motor rating (S3 15 %)	kW	18.7	18.7	18.7
	6.3 Battery acc. to DIN43531/35/36		no	no	no
	6.4 Battery voltage, nominal capacity K5	V/Ah	48 / 600 (715)	48 / 600 (715)	48 / 650 (715)
	6.5 Battery weight (min)	kg	995	995	1052
Misc.	8.1 Type of control		AC / Inverter	AC / Inverter	AC / Inverter
	8.2 Operating pressure for attachments	kg/cm2	Adjustable	Adjustable	Adjustable
	8.4 Sound level, driver's ear*3	dB (A)	69	69	69

*1 Further lift heights see upright table

*2 At friction coefficient $\mu=0.8$ with 1.6 km/h

*3 acc. to DIN EN 12053

All values shown are for standard lift truck with standard equipment. If the truck is supplied with options, values may change. All values given may vary + 5 % and - 10 % due to the motor and system tolerances and represent nominal values obtained under typical operating conditions. Specifications for Non-emission limited truck.

*Please contact your CLARK Dealer for specific model availability in your region.

Product Specifications acc. to VDI 2198

1.1 Manufacturer (Abbreviation)		CLARK	CLARK	
Specifications	1.2 Manufacturer's designation	EPX30i	EPX32i	
	1.3 Drive unit	Electro-48V	Electro-48V	
	1.4 Operator type stand on/driver seated	Rider-seated	Rider-seated	
	1.5 Load capacity/rated load	Q (Kg)	2980	3200
	1.6 Load centre distance	c (mm)	500	500
	1.8 Load centre distance, centre of drive axle to fork face x (mm)		475	480
	1.9 Wheelbase	y (mm)	1600	1600
Weight	2.1 Service weight	kg	4590	4835
	2.2 Axle loading, laden front/rear	kg	6686 / 884	7095 / 940
	2.3 Axle loading, unladen front/rear	kg	1946 / 2644	2050 / 2785
Tyres, Chassis	3.1 Tyre type, SE = superelastic		SE	SE
	3.2 Tyre size, front, superelastic		28 x 9 x 15	28 x 9 x 15
	3.3 Tyre size, rear, superelastic		18 x 7 x 8	18 x 7 x 8
	3.5 Wheels, number front/rear (x = drive wheels)		2 x / 2	2 x / 2
	3.6 Tread, front	b10 (mm)	1004	1004
	3.7 Tread, rear	b11 (mm)	915	915
	Dimensions	4.1 Tilt of upright/fork carriage	a/b deg	10 / 6
4.2 Height, upright lowered		h1 (mm)	2180	2180
4.3 Freelift		h2 (mm)	110	115
4.4 Lift height *1		h3 (mm)	3300	3165
4.5 Height, upright extended (with load backrest)		h4 (mm)	4520	4395
4.7 Height overheadguard		h6 (mm)	2210	2210
4.8 Seat height		h7 (mm)	1240	1240
4.19 Overall length		l1 (mm)	3584	3644
4.20 Length to face of forks		l2 (mm)	2517	2577
4.21 Width		b1 (mm)	1230	1230
4.22 Fork dimensions		s*e*l (mm)	45 x 120 x 1070	50 x 120 x 1070
4.23 Fork carriage DIN 15173, A, B			Class III A	Class III A
4.24 Fork carriage width		b3 (mm)	1040	1040
4.31 Ground clearance minimum, laden		m1 (mm)	150	150
4.32 Ground clearance centre of wheelbase		m2 (mm)	150	150
4.34 Stacking aisle for pallets (l6 • b12) 1000 x 1200 across Ast (mm)			4010	4061
4.34 Stacking aisle for pallets (l6 • b12) 800 x 1200 along Ast (mm)		4210	4261	
4.35 Turning radius	Wa (mm)	2335	2381	
4.36 Internal Turning radius	b13 (mm)	625	625	
Performance	5.1 Travel speed laden/unladen	km/h	16 / 16	15 / 15
	5.2 Lift speed laden/unladen	m/s	0.32 / 0.48	0.25 / 0.44
	5.3 Lowering speed laden/unladen	m/s	0.55 / 0.50	0.47 / 0.43
	5.6 Max. drawbar pull laden/unladen (S2 5 min) *2	N	1582 / 1080	1380 / 824
	5.8 max. gradeability laden/unladen (S2 5 min) *2	%	19.2 / 18.9	17.5 / 17.6
	5.10 Service brake		Drum	Drum
Drive line	6.1 Drive motor rating (S2 60 min)	kW	15	15
	6.2 Lift motor rating (S3 15 %)	kW	18.7	18.7
	6.3 Battery acc. to DIN43531/35/36		no	no
	6.4 Battery voltage, nominal capacity K5	V/Ah	48 / 740 (850)	48 / 740 (850)
	6.5 Battery weight (min)	kg	1770	1770
Misc.	8.1 Type of control		AC / Inverter	AC / Inverter
	8.2 Operating pressure for attachments	kg/cm2	Adjustable	Adjustable
	8.4 Sound level, driver's ear*3	dB (A)	69	69

*1 Further lift heights see upright table

*2 At friction coefficient $\mu=0.8$ with 1.6 km/h

*3 acc. to DIN EN 12053

All values shown are for standard lift truck with standard equipment. If the truck is supplied with options, values may change. All values given may vary + 5 % and - 10 % due to the motor and system tolerances and represent nominal values obtained under typical operating conditions. Specifications for Non-emission limited truck.

*Please contact your CLARK Dealer for specific model availability in your region.

GENERAL DATA

Truck Capacities Capacity at different load centres

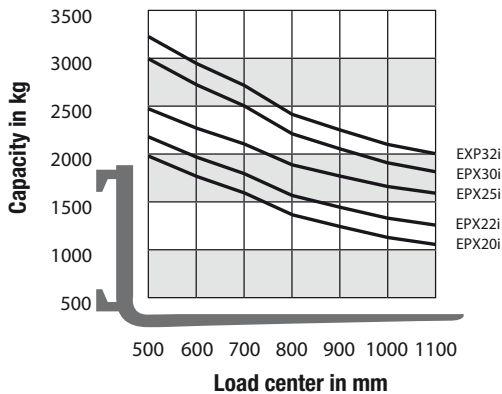

Note:

The listed capacities are valid only for the standard upright in vertical position with standard fork carriage and standard forks, up to max. lifting height of 3085 mm. The centre of gravity of the load may be displaced by max. 100 mm against the longitudinal centre plane of the truck. Load centre is determined from top and front face of the forks. The values are based on a 1000 mm cube load configuration with the centre of gravity at the true centre of the cube with upright tilted forward lower capacity values are valid. Attachments, longer forks, exceptional load dimensions and higher lifting heights can reduce the capacity. Please talk to your CLARK dealer if you require further information.

Upright table EXP20i/22i/25i/30i

Mast type	Maximum Fork Height (h3)	Mast Lowered (h1)	Mast Extended (h4)		Free Lift (h2)	
			with load backrest	without load backrest	with load backrest	without load backrest
			mm	mm	mm	mm
Standard	2020	1575	3340	2718	110	110
	2680	1855	3900	3278		
	2980	2005	4200	3578		
	3300	2165	4520	3898		
	3725	2455	4944	4322		
	3860	2530	5080	4458		
	4165	2800	5384	4762		
	4380	3000	5600	4978		
	4620	3230	5840	5218		
5170	3495	6390	5768			
Triple	3860	1855	5079	4483	636	1232
	4320	2005	5539	4943	786	1382
	4600	2100	5824	5228	881	1477
	4800	2165	6019	5423	946	1542
	5210	2305	6429	5833	1086	1682
	5520	2455	6739	6143	1236	1832
	5740	2530	6959	6363	1311	1907
	6100	2690	7319	6723	1471	2067
	6370	2800	7589	6993	1581	2177
6830	3000	8049	7453	1781	2377	
7315	3230	8534	7938	2011	2607	
HI-LO	2935	2005	4155	3559	786	1382
	3255	2165	4475	3879	946	1542
	3530	2305	4750	4154	1086	1682
	3760	2455	4980	4384	1236	1832
	3910	2530	5128	4532	1311	1907

Upright table EPX32i

Mast type	Maximum Fork Height (h3)	Mast Lowered (h1)	Mast Extended (h4)		Free Lift (h2)	
			with load backrest	without load backrest	with load backrest	without load backrest
			mm	mm	mm	mm
Standard	1985	1590	3215	2662	115	115
	2545	1870	3775	3222		
	2845	2020	4075	3522		
	3165	2180	4395	3842		
	3300	2233	4526	3973		
	3590	2470	4819	4266		
	3725	2545	4955	4402		
	4030	2815	5255	4702		
	4245	3015	5471	4918		
	4485	3245	5711	5158		
5035	3510	6261	5708			
Triple	3680	1870	4899	4368	651	1182
	4140	2020	5363	4832	801	1332
	4620	2180	5843	5312	961	1492
	4800	2180	6024	5493	961	1492
	5030	2320	6253	5722	1101	1632
	5340	2470	6563	6032	1251	1782
	5560	2545	6783	6252	1326	1857
	5920	2705	7143	6612	1486	2017
	6190	2815	7409	6878	1596	2127
	6650	3015	7868	7337	1796	2327
7135	3245	8354	7823	2026	2557	

Note:

Mast lowered (h1) and freelif (h2) for EPX30i are 15 mm higher than above mentioned values.

Performance may vary + 5 % and - 10 % due to motor and system efficiency tolerance. The performance shown represents nominal values which may be obtained under typical operating conditions of a machine. CLARK products and specifications are subject to change without notice.

*Please contact your CLARK Dealer for specific model availability in your region.

PRODUCT DESCRIPTION



The EPX20i-32i series CLARK forklift is a quiet, non-polluting operation alternative to internal combustion engine trucks. The robust electric counterbalanced range trucks are suitable for most applications with handling capacities from 2,0 to 3,2 tons. A solid built to last construction with a well-designed driver compartment makes the Clark EPX20-32i series the truck you need to operate in a smart and safe manner over long periods.

Operator's Compartment

A large low positioned step, together with a grab handle on the driver's guard column allows easy access to the ergonomically designed operator's compartment. A full width rubber floor covering in the footwell ensures a firm footing in all conditions. The tilting steering column and an easily adjustable comfort seat, gives maximum legroom enabling optimal adjustment to suit any driver. The operator's foot pedals are arranged in the automotive fashion to avoid any confusion.

Fully directional operating levers move smoothly giving precise control and are located at a perfect position to enable easy handling and a firm grip. Essential operating data is displayed in real-time on the clear TFT LCD colour display.

Two individually programmable modes of operation (Turtle-Normal), as well as an additional crawl function, allows the truck be optimally adapted to all relevant work applications. Easily accessible storage compartments as well as quick access to the park brake completes the impressive operator compartment.

Motor, drive and control

A front axle mounted 15.0 kW AC drive motor and 48 Volt three-phase current technology gives excellent acceleration and performance.

Maintenance free AC motors will keep running costs to a minimum. The temperatures of the motors and controller are constantly monitored with the power being automatically adjusted to prevent design limits being exceeded. The ZAPI AC3 INVERTER controller is equipped with modern MOSFET and CAN bus technology which is located and protected in a safe position in the counterweight, yet easily accessible for service. The motor and controller temperature monitoring devices serve to protect your investment.

Brake system

Three independent brake systems (electronic, service and parking brake) brings increased efficiency through improved utilisation of the battery capacity and better safety. The adjustable drum service brake, foot and parking brake provide constant brake performance.

Regenerative electronic braking returns energy to the battery during each braking action. This process saves energy costs, reduces brake wear and extends the driving time per battery cycle.

When changing direction, the electronics give a smooth braking action and progressive acceleration when moving in the chosen travel direction. The standard ramp start feature brings controlled operation of the truck on gradients and precise handling on loading platforms.

Steering system

The hydrostatic EPX20-32i steering system makes the truck, extremely manoeuvrable. Good steering wheel turn angles allows these trucks to work in narrow working aisles.

Hydraulic system

The independent, AC powered hydraulic pump only pumps the necessary volume of oil for the task at hand, ensuring optimum energy efficiency and longer battery shift cycles. The internal gear hydraulic pump is notable by a particularly low pumping frequency combined with high efficiency. This saves energy and reduces the thermal loads on the hydraulics. The full-flow return line filtration filters the oil to the tank at each reverse flow. Large particles are filtered directly via a suction filter, thereby preventing them from entering the oil circuit. This ensures a long service life for all hydraulic components.

Upright

The clear-view uprights are available in Standard, Hilo and Triplex versions. The interlocking profiles provide high strength and improved safety, even at high racking heights. Enclosed canted rollers minimize deflection and can easily be adjusted without major disassembly.

Tilt cylinders are mounted in spherical bushings, eliminating hydraulic seal strain, thereby increasing the service life of the complete cylinder. An integral tilt-lock valve prevents excessive tilt speeds and unintentional operation of the upright.

A hydraulic cushioning valve reduces upright shock and allows smooth lifting and lowering at all times, thus ensuring a long service life and reduced product damage. The sturdy 6-roller fork carriage features enclosed canted rollers together with adjustable side thrust rollers, preventing carriage jamming when handling offset loads.

Further standard equipment

Two protected headlights, combination rear lights with brake and reverse light, paintwork in bright safety „CLARK “Hot Yellow Green”, driver compartment and upright in matt black, and white wheel rims to finish.

Optional equipment

Non-marking tyres, side battery removal system, acoustic backup alarm, fork positioner or hook-on type side shifter, driver seats with armrest or hip restraint and much more.

Safety

The EXPi-Series conforms to all CLARK safety standards for counterbalanced forklift trucks.

Talk to your CLARK dealer to find your optimum choice equipment.

CLARK International South Pacific
30 Salisbury Road
Hornsby, NSW 2077 Australia
Tel: 1800 005 747
Website: www.clarkforklifts.com.au

CLARK International Singapore
2 Venture Drive, #12-28 Vision Exchange
Singapore, 608526
Tel: 65 6863 4083
Website: www.clarkforklifts.com.au

Dealer: