

EQAO Preparation

Grade 9 Academic Mathematics

Table of Contents:

How to Master Multiple Choice Questions.....	4
Formula Sheets.....	5

Strand 1: Number Sense & Algebra

EQAO Sample Questions.....	7
1-1: Exponent Laws.....	9
1-2: Polynomials.....	10
1-3: Distributive Property.....	11
1-4: Solving Equations.....	11
Re-test.....	12
Answers.....	13

Strand 2: Measurement & Geometry

EQAO Sample Questions.....	16
2-1: Pythagorean Theorem.....	18
2-2: Optimization.....	19
2-3: Composite Figures.....	20
2-4: Surface Area & Volume.....	21
2-5: Angle & Triangle Theorems.....	23
2-6: Parallel Line Theorems.....	24
2-7: Polygons Theorems.....	25
Re-test.....	26
Answers.....	27

Strand 3: Analytical Geometry & Linear Relations

EQAO Sample Questions.....	29
3-1: Linear vs. Non-Linear.....	31
3-2: Forms to Represent Linear Equations.....	32
3-3: Methods of Graphing.....	33
3-4: Generating an Equation.....	34
3-5: Special Lines.....	35
3-6: Linear Systems.....	36
3-7: Scatter Plots & Lines of Best Fit.....	37
Re-test.....	39
Answers.....	40

How to Master Multiple Choice Questions

1 Start with the questions you find the easiest. This will build your confidence for tackling the harder questions, and may even provide you with information you have forgot.

2 Read the question carefully. Highlight information that you need to consider when answering the question. Identify any **key words**, or formulas that can assist you in answering the question.

3 Don't read the answers provided. This may seem backwards, but using a "cover up" strategy may help you to answer correctly because you will be less persuaded by the incorrect responses that are there to confuse you. Once you have attempted the question on your own look to see if your answer is one of the four possible choices.

4 Don't select your answer. There are answers provided to trick you based on common mistakes that students make. Before selecting your answer, cross out all the other possibilities and reason through why they cannot be the correct choice. This will encourage you to consider the problem from a different perspective and ensure you did not misread the information provided.

5 Budget your time. Multiple choice questions should take no more than 1-2 minutes. If you are taking longer than that on any one question, place a big question mark beside it and move on to the next.

6 Review your answers. Go back and finish any questions you identified as being incomplete. If you still don't know, make an informed guess, cross off any obviously incorrect responses and choose from the remaining options. You have a 25% chance of being correct.

Formula Sheet

Grade 9 Academic

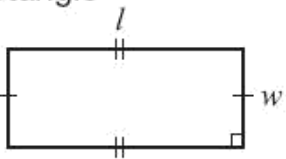
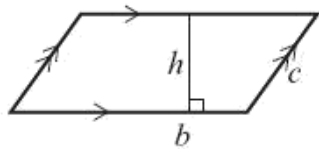
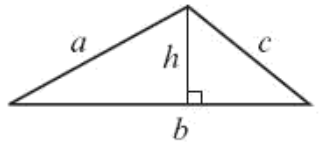
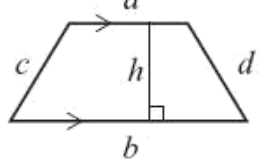
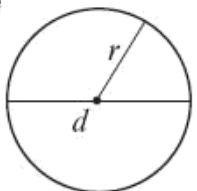
Geometric Figure	Perimeter	Area
<p>Rectangle</p> 	$P = l + l + w + w$ or $P = 2(l + w)$	$A = lw$
<p>Parallelogram</p> 	$P = b + b + c + c$ or $P = 2(b + c)$	$A = bh$
<p>Triangle</p> 	$P = a + b + c$	$A = \frac{bh}{2}$ or $A = \frac{1}{2}bh$
<p>Trapezoid</p> 	$P = a + b + c + d$	$A = \frac{(a + b)h}{2}$ or $A = \frac{1}{2}(a + b)h$
<p>Circle</p> 	$C = \pi d$ or $C = 2\pi r$	$A = \pi r^2$

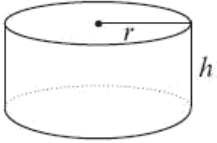
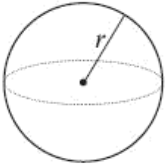
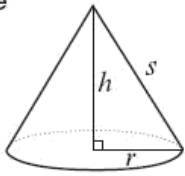
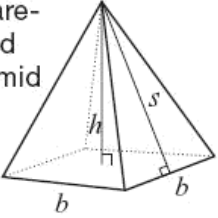
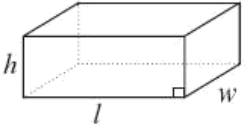
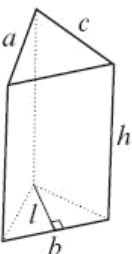
Geometric Figure	Surface Area	Volume
Cylinder 	$A_{\text{base}} = \pi r^2$ $A_{\text{lateral surface}} = 2\pi r h$ $A_{\text{total}} = 2A_{\text{base}} + A_{\text{lateral surface}}$ $= 2\pi r^2 + 2\pi r h$	$V = (A_{\text{base}})(\text{height})$ $V = \pi r^2 h$
Sphere 	$A = 4\pi r^2$	$V = \frac{4}{3}\pi r^3$ or $V = \frac{4\pi r^3}{3}$
Cone 	$A_{\text{lateral surface}} = \pi r s$ $A_{\text{base}} = \pi r^2$ $A_{\text{total}} = A_{\text{lateral surface}} + A_{\text{base}}$ $= \pi r s + \pi r^2$	$V = \frac{(A_{\text{base}})(\text{height})}{3}$ $V = \frac{1}{3}\pi r^2 h$ or $V = \frac{\pi r^2 h}{3}$
Square-based pyramid 	$A_{\text{triangle}} = \frac{1}{2}bs$ $A_{\text{base}} = b^2$ $A_{\text{total}} = 4A_{\text{triangle}} + A_{\text{base}}$ $= 2bs + b^2$	$V = \frac{(A_{\text{base}})(\text{height})}{3}$ $V = \frac{1}{3}b^2 h$ or $V = \frac{b^2 h}{3}$
Rectangular prism 	$A = 2(wh + lw + lh)$	$V = (A_{\text{base}})(\text{height})$ $V = lwh$
Triangular prism 	$A_{\text{base}} = \frac{1}{2}bl$ $A_{\text{rectangles}} = ah + bh + ch$ $A_{\text{total}} = A_{\text{rectangles}} + 2A_{\text{base}}$ $= ah + bh + ch + bl$	$V = (A_{\text{base}})(\text{height})$ $V = \frac{1}{2}blh$ or $V = \frac{blh}{2}$

Strand 1:

Number Sense & Algebra

EQAO Sample Questions:

1. What is the value of $6x^2$ when $x = \frac{1}{3}$?
- a $\frac{2}{9}$
 - b $\frac{2}{3}$ -
 - c 2
 - d 4

See 1-1

2. Which value of x satisfies the equation $5 - 2x = 9$?
- a $x = -7$
 - b $x = -2$
 - c $x = 2$
 - d $x = 3$

See 1-4

3. Consider the expression below.

$$3x^2(5x^2 - 2x + 1)$$

Which of the following is equivalent to this expression?

- a $8x^2 - 2x + 1$
- b $8x^2 + x + 4$
- c $15x^4 - 2x + 1$
- d $15x^4 - 6x^3 + 3x^2$

See 1-2

4. The sum of the perimeters of two shapes is represented by $13x + 4y$. The perimeter of one shape is represented by $4x - 2y$. Which expression represents the perimeter of the other shape?

- a $9x + 2y$
- b $9x + 6y$
- c $17x + 2y$
- d $17x + 6y$

See 1-2

5. Which of the following is equivalent to the expression below?

$$(4x - 5) + (2x + 1)$$

- a $2x - 6$
- b $2x - 4$
- c $6x - 6$
- d $6x - 4$

See 1-2

6. Alfredo and his wife, Jody, work in a restaurant. Last week Alfredo received an average of \$15 in tips for each of the 55 tables he served. Jody received an average of \$20 in tips for each of the 60 tables she served. They are planning a weekend trip. Alfredo will pay a total of \$220 for their hotel room and Jody will pay a total of \$160 for their rental car. How much of their combined tips will be left over after they have paid for their hotel room and rental car?

- a \$1620
- b \$1645
- c \$2025
- d \$2405

See 1-4

7. What is the value of $(x^2)^3$ when $x = \frac{1}{2}$?

a $\frac{1}{4}$

b $\frac{1}{12}$

c $\frac{1}{32}$

d $\frac{1}{64}$

See 1-1

8. Meg has been asked to determine the value of the numerical expression below.

$$\frac{2^{400}}{2^{396}} - 2^3$$

Which of the following is the value of Meg's expression?

a 1

b 2

c 4

d 8

See 1-1

8. Part-Time Job

Ezre works part-time at a clothing store. He earns \$80 per week plus 6% of the value of his weekly sales. This week Ezre earns \$119.

What is the total value of his sales this week? Show your work

See 1-4

10. Keepin' Tabs

A student council collects aluminum pop tabs to raise money to purchase a wheelchair. A company buys the pop tabs for \$0.88 per kilogram.

If 1267 pop tabs have a mass of one pound, how many pop tabs are needed to purchase a wheelchair worth \$1500?

Show your work.

HINT:

1 kilogram = 2.2
pounds

See 1-4

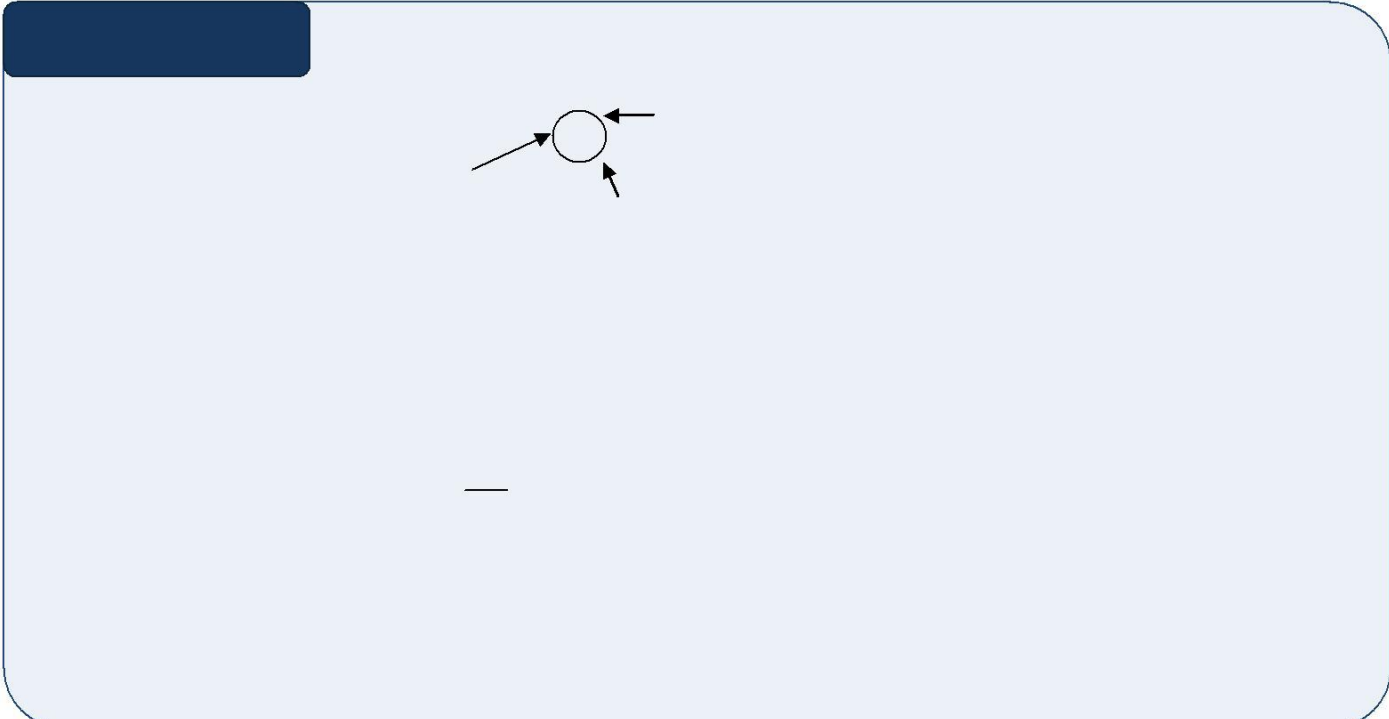

1-1 Exponent Laws:

Key Concepts

Terminology:



Multiplication Law: where multiplying powers with the SAME BASE you ADD the EXPONENTS. $(a^n)(a^m) = a^{n+m}$

Division Law: where dividing powers with the SAME BASE you SUBTRACT the EXPONENTS. $\frac{a^n}{a^m} = a^{n-m}$

Power Law: where there is a power of a power you MULTIPLY the EXPONENTS $(a^n)^m = a^{nm}$

1. Simplify the following.

a) $p \times p^4$

b) $2a^2 \times 4a^3 \times a^4$

c) $(-9x^4)(6x^3)$

d) $(3x^2y)(4xy^2)(-2x^3y)$

e) $\frac{x^9}{x^2}$

f) $\frac{x^5y^8}{xy^2}$

g) $\frac{-24x^6y^{12}z^{10}}{-3x^2y^6z^2}$

h) $(a^2)^{12}$

i) $(a^3b^2)^4$

j) $(-2y^3)^3$

k) $\frac{(x^2)^3}{(x^3x)}$

l) $\left[\frac{(-3a^2b)^3(2b)^2}{18a^3b^4} \right]^3$

m) $\left[\frac{3(x^2y)^5}{(-2xy)^2(x^3)^2} \right]^2$

1-2 Polynomials:

Key Concepts

Polynomial: terms that are separated by addition and/or subtraction

- Can be classified according to their number of terms: monomial (1 term), binomial (2 terms), trinomial (3 terms).

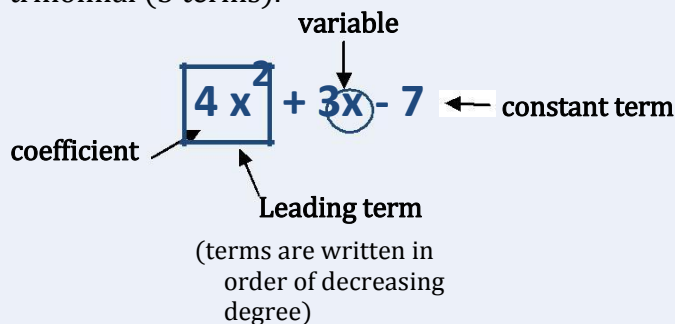

Term: has a coefficient and/or a variable (exponent on variable must be a natural number)

Coefficient: the number and the sign that is in front of the variable

Degree: the value of the exponent on the variable

A constant: a term that does not have a variable

Like terms: terms that have the same variable with the same exponent, only like terms can be added or subtracted

1. Complete the chart below:

Expression	Number of Terms	Coefficient of x	Constant
$3x$			
$7x - 9y$			
$4x^2 - 3x + 7$			
$-5x + 13$			
$2x^3 - 6x^2 + 9x + 1$			

2. Circle the like terms:

a) $-6k, -10, 7k$

b) $-r, 8r^2, 10r^3, -10r$

c) $x^4y^2, 5x^2y^4, 2xy^4, (3x^2y)^2$

d) $0.7mn^3, 2mn^2, \frac{1}{2}mn, -17mn^3$

3. Simplify the expression:

a) $-6k + 7k$

b) $n - 10 + 9n - 3$

c) $12r + 5 + 3r - 5$

d) $5a^2 + 3a^2x - 7a^3 + 2a^2 - 8a^2x + 4$

e) $(6x^2 + 4x + 1) - (4x + 20)$

f) $(8x^3 - 6x + 10) - (x^3 + 10x - 9)$

1-3 Distributive Property:

Key Concepts

Distributive Property: distribute the term or constant to each term or constant inside the parentheses.

$$a(b + c) = ab + ac$$

1. Expand and simplify where necessary.

a) $-6(a + 8)$

b) $3a(4x + 2y)$

c) $x^2 y^2 (2x + 3y)$

d) $(5x^2 + 3x + 7)(9xy)$

e) $4(5x - 1) - 5(3x + 2)$

f) $-(4 + 3n) - 8(n + 7)$

g) $\frac{3}{2}\left(\frac{1}{3}a - \frac{2}{3}b\right) - \frac{3}{4}\left(\frac{1}{3}a + \frac{2}{3}b\right) + 8$

1-4 Solving Equations:

Key Concepts

Equation: contains two expressions which are equivalent. For example: $2x + 3 = 7$

Expression: a representation of a quantity. For example: $7x + 1$

Solving Equations: solve multi-step equations by applying inverse order of operations

****KEEP IT SIMPLE:** Eliminate fractions as early as possible by **MULTIPLYING** by the **DENOMINATOR**

1. Solve for the unknown variable.

a) $5x + 1 = 31$

b) $6x + 4 = 20 - 2x$

c) $5(x + 2) = 25$

d) $4(5x - 3) = 7(2x + 3)$

e) $-\frac{5}{6}x = \frac{3}{4}$

f) $m + \frac{2}{3} = \frac{1}{4}m - 1$

g) $\frac{2}{3}(3x + 1) = 5$

h) $\frac{1}{2} + \frac{2}{5}t - 1 = \frac{1}{5}t + t$

Re-test

1. Simplify the following expression.

$$(x^2 + 4x + 3) + x(3 - x) ?$$

- a $x + 3$
- b $3x$
- c $7x + 3$
- d $-2x^2 + 4x + 3$

2. Eric and Julie are each asked to solve an equation. Who has correctly solved his or her equation?

- a Eric only
- b Julie only
- c Both Eric and Julie
- d Neither of them

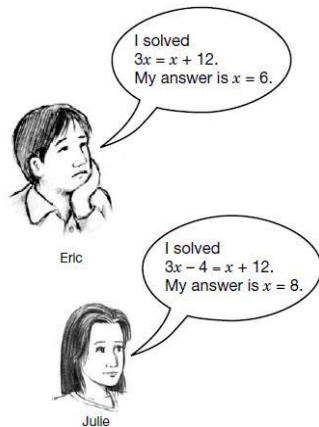

3. Pierre and his friends order from a hot dog stand.



Based on the price list given, how many hot dogs and colas do they buy with \$17.80?

- a 3 hot dogs and 5 colas
- b 5 hot dogs and 3 colas
- c 6 hot dogs and 4 colas
- d 5 hot dogs and 5 colas

4. Simplify fully:

$$-5x(4 - 3x) + 2x^2$$

- a $2x^2 - 17x$
- b $2x^2 - 23x$
- c $17x^2 - 5x$
- d $17x^2 - 20x$

5. Simplify the following algebraic expression:

$$\frac{a^6 b^4}{a^2 b}$$

- a $\frac{a^3}{b^3}$
- b $\frac{a^4}{b^3}$
- c $a^3 b^3$
- d $a^4 b^3$

6. Tim shows the steps he took in simplifying the following algebraic expression:

$$\frac{(a^2)^3}{a^2 \times a^3}$$

$$= \frac{a^5}{a^2 \times a^3} \quad \text{Step 1}$$

$$= \frac{a^5}{a^{2+3}} \quad \text{Step 2}$$

$$= \frac{a^5}{a^5} \quad \text{Step 3}$$

$$= 1 \quad \text{Step 4}$$

Which step has an error in it?

- a Step 1
- b Step 2
- c Step 3
- d Step 4

Answers

EQAO Multiple Choice

1. B 2. B 3. D 4. B 5. D
 6. B 7. D 8. D 9. \$ 650 10. 4,751,250

1-1 Exponent Laws

1. a) p^5 e) x^2 i) $a^{12}b^8$ m) $\frac{9x^4y^6}{16}$
 b) $8a^9$ f) x^4y^6 j) $-8y^2$
 c) $-54x^7$ g) $8x^4y^6z^8$ k) x^5
 d) $-24x^6y^4$ h) a^{24} l) $-216a^9b^3$

1-2 Polynomials

1.

Expression	Number of Terms	Coefficient of x	Constant
$3x$	1	3	0
$7x - 9y$	2	7	0
$4x^2 - 3x + 7$	3	-3	7
$-5x + 13$	2	-5	13
$2x^3 - 6x^2 + 9x + 1$	4	9	1

2. a) $-6k, 7k$ b) $-r, -10r$
 c) $x^4y^2, (3x^2y)^2$ d) $0.7mn^3, -17mn^3$
 3. a) k d) $-7a^3 + 7a^2 - 5a^2x + 4$
 b) $10n - 13$ e) $6x^2 - 19$
 c) $15r$ f) $7x^3 - 16x + 19$

1-3 Distributive Property

1. a) $-6a - 48$ e) $5x - 14$
 b) $12ax + 6ay$ f) $-11n - 60$
 c) $2x^3y^2 + 3x^2y^3$ g) $\frac{1}{4}a - \frac{3}{2}b + 8$
 d) $45x^3y + 27x^2y + 63xy$

1-4 Solving Equations

1. a) $x = 6$ c) $x = 3$ e) $x = \frac{-9}{10}$ g) $x = \frac{13}{6}$
 b) $x = 2$ d) $x = \frac{33}{6}$ f) $x = \frac{-20}{9}$ h) $x = \frac{-5}{8}$

Re-test

1. C 2. C 3. B 4. D 5. D 6. A

Strand 2:

Measurement & Geometry

EQAO Sample Questions:

1. A garden is in the shape of a rectangle and a semicircle as shown below.

Which of the following is closest to the amount of fencing needed to enclose the garden?

- a 60 cm
- b 70 cm
- c 75 cm
- d 85 cm

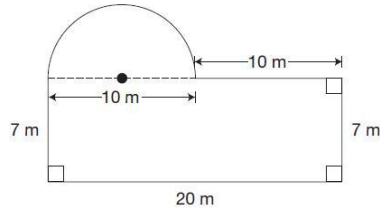

See 2-2

2. Ella wants a rectangle with:

- a perimeter of 100 cm and
- the largest possible area.

What are the dimensions of the rectangle that satisfies her conditions?

- a 10 cm x 10 cm
- b 20 cm x 30 cm
- c 25 cm x 25 cm
- d 40 cm x 60 cm

See 2-2

3. Chris has a square garden with an area of 38.4 m^2 , as shown in the diagram.



He decreases the length of each side by 1.7m to make a smaller garden. Which is the closest to the perimeter of the smaller garden?

- a 37 m
- b 32 m
- c 25 m
- d 18 m

See Formula Sheet

4. Consider the parallelogram shown below. What is the perimeter of WXYZ?

- a 28 cm
- b 30 cm
- c 31 cm
- d 34 cm

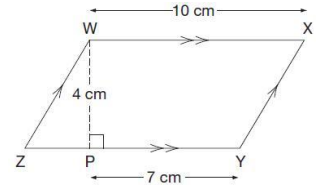

See 2-1

5. Consider the diagram below.

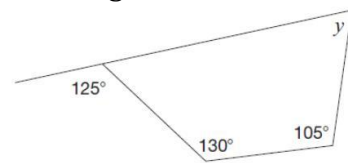

- a 55°
- b 70°
- c 125°
- d 130°

See 2-4

6. The playing chips of a board game are stored in cylindrical plastic cases. The plastic cases have a volume of 25120 mm^3 and a diameter of 40 mm. Which of the following is closest to the height of one playing chip if 50

playing chips can fit tightly into the plastic case as shown above?



Plastic Case
← 40 mm →

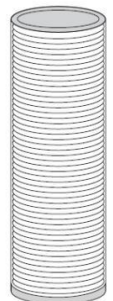

- a 0.1 mm
- b 0.4 mm
- c 1.3 mm
- d 2.5 mm

See 2-3

7. Consider the following diagram.

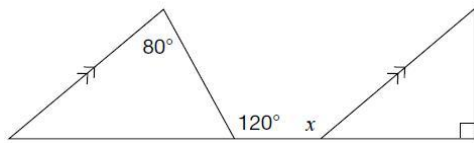

What is the value of x ?

- a 80°
- b 120°
- c 140°
- d 170°

See 2-4 & 2-5

8. What is the sum of the interior angles of a 12-sided regular polygon?

- a 1080°
- b 1800°
- c 1980°
- d 2160°

See 2-6

9. Toy Sailboats

Emelina makes toy sailboats as shown below. Determine the total area of the shaded sails. Show your work

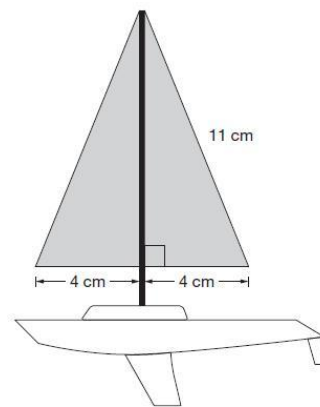

See 2-1

10. What's Missing?

Consider the diagram below.

Complete the table below. Justify your answers using geometric properties.

Angle measure	Justification
$x = \underline{\hspace{2cm}}$	
$y = \underline{\hspace{2cm}}$	

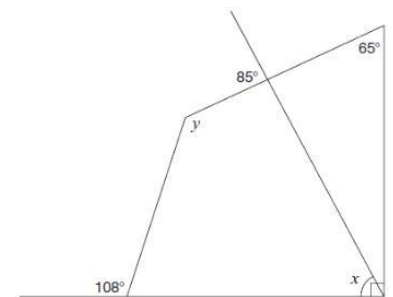

See 2-4

2-1 Pythagorean Theorem:

Key Concepts

Hypotenuse: the longest side of the right triangle, opposite to the 90° angle.

Pythagorean Theorem: in a right angle triangle, the square of the length of the hypotenuse is equal to the sum of the squares of the lengths of the two shorter sides.

$$a^2 + b^2 = c^2$$

1. Find the missing length to the nearest tenth.

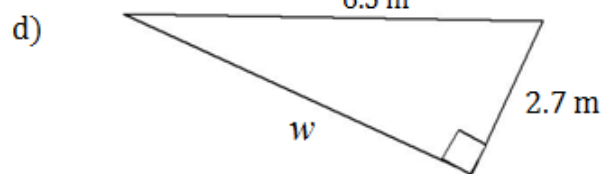
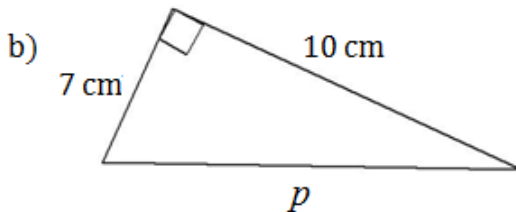
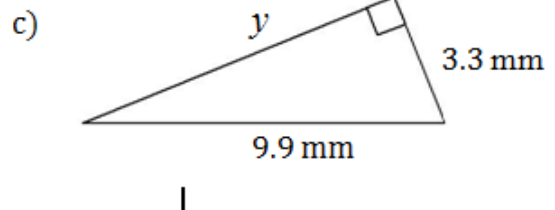
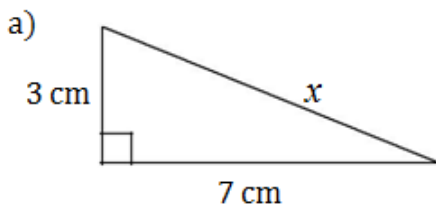

- A baseball diamond is a square with sides of 90 feet. What is the shortest distance, to the *nearest tenth* of a foot, between first base and third base?
- Two joggers run 3 miles north and 8 miles west. What is the shortest distance, to the *nearest tenth* of a mile, that they must travel to return to their starting point?
- Tv's are measured across the diagonal. You don't have a ruler long enough to measure the size of your tv. The only measurements you have are the two sides lengths: 48 inches and 36 inches. What size is your tv?

2-2 Optimization:

Key Concepts

Optimization: creating the largest or smallest area or perimeter given restrictions.

Maximum area: when obtaining a maximum rectangular area:

-enclose 2 or 4 sides forming a square

-enclose 3 sides forming a rectangle where the length is double the width

Minimum perimeter: when obtaining a minimum perimeter of a rectangular area, form a square.

1. Paula plans to build a rectangular patio using 180 m of fencing. What is the maximum area of the patio that she can build?
2. Cody needs to make a rectangular pen for his pigs that will enclose a total area of 256 square feet. What is the maximum length of fencing that he will need?
3. Ella wants a new vegetable garden. She needs 144 m² of space for her vegetable plants. What is the least amount of fencing that she will need to purchase?
4. A doggy day care is looking to create an outdoor area for the dogs boarding for the day. There is 900 m of fencing available to enclose the area. Which shape offers the largest area: a rectangular pen or a circular pen?
5. While working at a summer camp on the lake you are asked to create a swimming enclosure for the campers. You have 900 feet of rope with buoys on it. What are the dimensions of the maximum area that can be enclosed? What area will be created?

2-3 Composite Figures:

Key Concepts

Composite Figures: figures that are made up of two or more two-dimensional figures: triangles, squares, rectangles, semicircles, etc.

1. Calculate the area and perimeter, *to the nearest tenth*, of each of the figures.

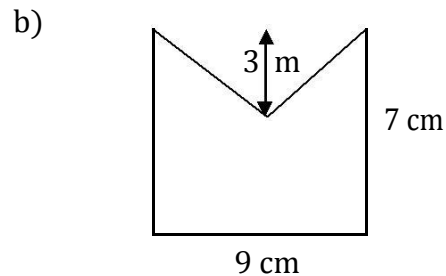
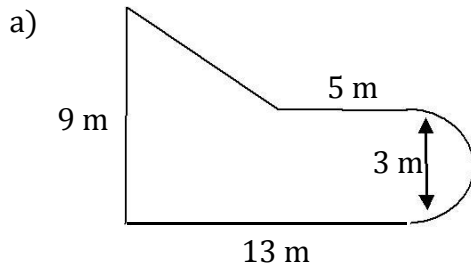

2. The diagram shows a running track at a high school. It consists of two parallel line segments with a semicircle at each end. The track is 10m wide. Kayla runs on the inside of the track and Emily runs on the outer edge. How much farther does Emily run in one lap, than Kayla?

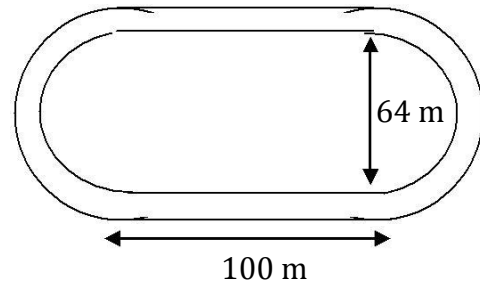

3. Bradley is planning a garage sale. To direct customers to his house, he is painting six arrow signs.

a) Calculate the area of one sign.

b) Each can of paint can covers 10 cm^2 . How many cans of paint should Bradley buy for all six signs. Explain your answer.

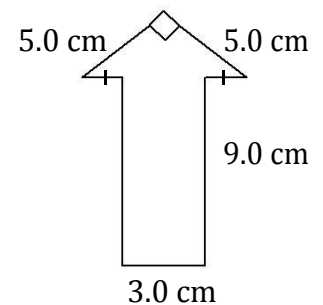

2-4 Surface Area & Volume:

Key Concepts

Surface Area: the number of square units needed to cover the surface of a 3-D object.

Lateral Faces: the faces of a prism or pyramid that are not bases.

Volume: the amount of space that an object occupies, measured in cubic units.

Prism: a 3-D object with two parallel congruent polygonal bases.

$$\text{Volume of Prism} = \text{AREA of the BASE} \times \text{Height}$$

Pyramid: a 3-D object with one polygonal base and all lateral surfaces meeting at an apex.

$$\text{Volume of Pyramid} = \frac{\text{AREA of the BASE} \times \text{Height}}{3}$$

3

1. Calculate the volume of each pyramid, *to the nearest tenth*.

a)

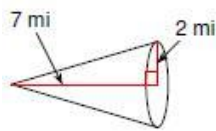

b)

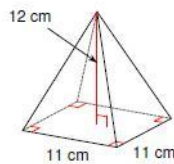

c)

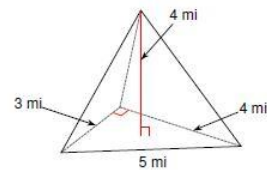

2. Calculate the volume of each prism, *to the nearest tenth*. a) b) c)

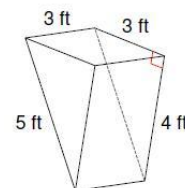
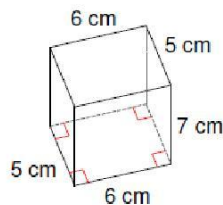
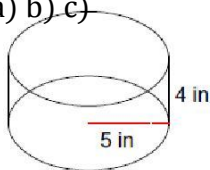

3. Calculate the surface area of each pyramid, *to the nearest tenth*.

a)

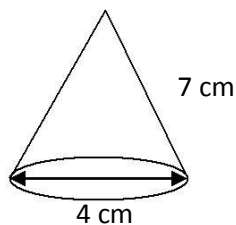

b)

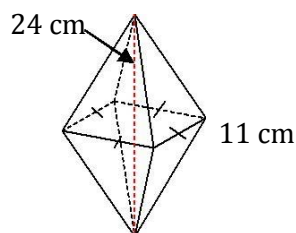

c)

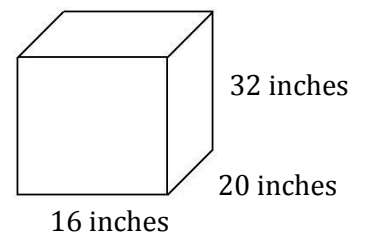

4. Calculate the surface area of each prism, *to the nearest tenth*.

a)

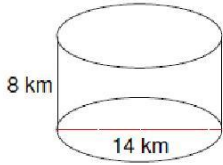

b)

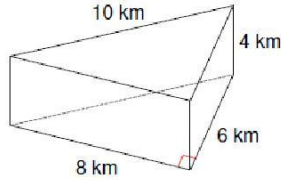

c)

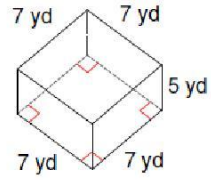

5. The Great Pyramids of Khufu is located in Egypt. It is 481 feet high and has a square base with a base edge of 756 feet. What is the surface area of the Great Pyramid? Round your answers to two decimal places.
6. Lindsey buys mulch for her flower garden. How many cubic feet of mulch will fit in her truck bed that is 5 feet by 8 feet by 2 feet?
7. A water tank has been purchased for the farm. It will be used to water cattle. It is a cylindrical shaped metal container that is 2.6 feet tall. The area of the bottom of the tank is 9.3 square feet. If the cattle drink two hundred four cubic feet of water a day, how many times per day will the tank have to be filled?
8. Jen found a plant holder at a garage sale, in the shape of a square frustum. The frustum has a slant height of 40 cm, a base width of 35 cm, and a top width of 17 cm. She needs to give it a fresh coat of paint. How much surface area will she need to cover?

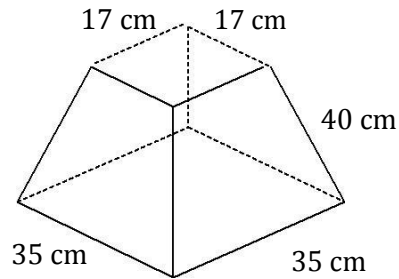

2-5 Angle & Triangle Theorems:

Key Concepts

Complementary Angles: two angles on a right angle which sum to 90 degrees.

Supplementary Angles: two angles on a straight line which sum to 180 degrees.

Opposite Angles: two angles on the same intersection opposite to each other are equal.

Equilateral Triangle Theorem: all side lengths and all angles are equal.

Isosceles Triangle Theorem: two sides lengths and their opposite angles are equal.

Sum of Angle Triangle Theorem: all interior angles in a triangle add to 180 degrees.

Remote Interior Angle Triangle Theorem: the exterior angle at each vertex of a triangle is equal to the sum of the two interior angles opposite to it.

1. Find the value of the missing angles.

a)

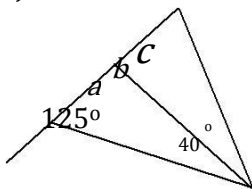

b)

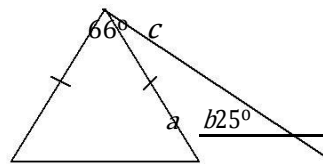

2. Find the measure of each indicated angle.

a)

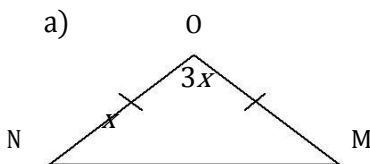

b)

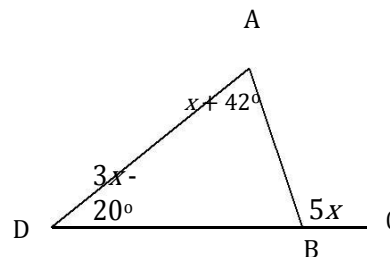

3. Find the value of each variable. A

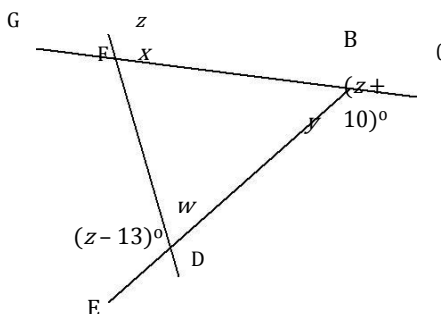

2-6 Parallel Line Theorems:

Key Concepts

Corresponding Angles: pairs of corresponding angles associated with a transversal are equal.

Alternate Angles: pairs of alternate angles associated with a transversal are equal.

Co-interior Angle: pairs of co-interior angles associated with a transversal have a sum of 180 degrees.

1. Find the measure of each of the unknown angles indicated.

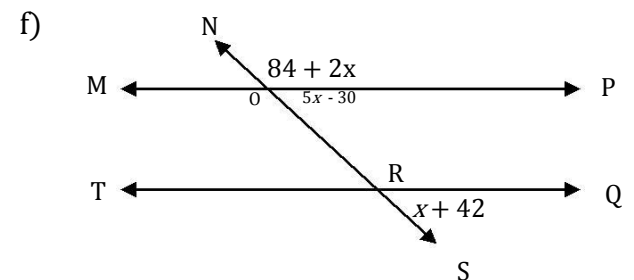
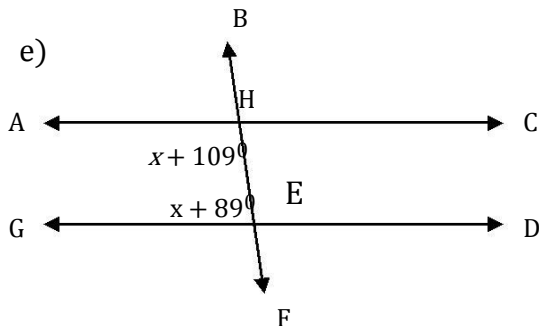
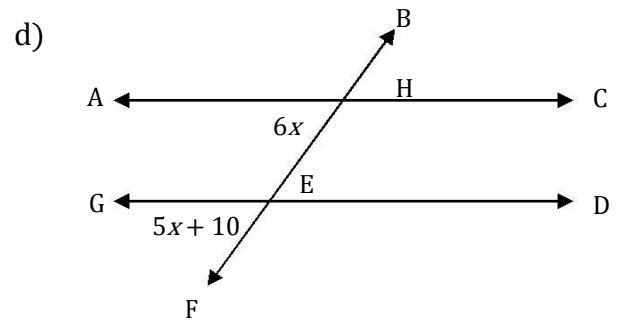
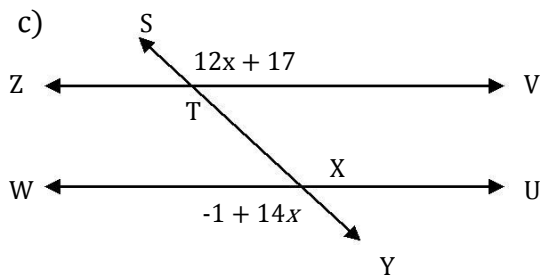
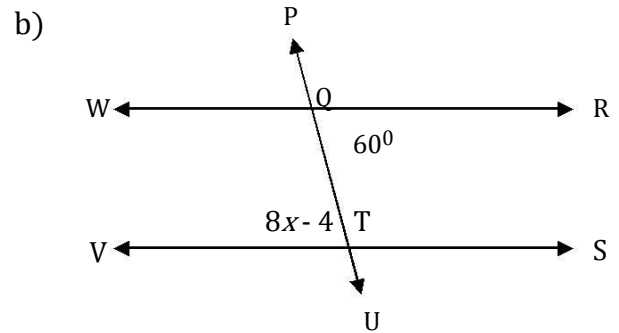
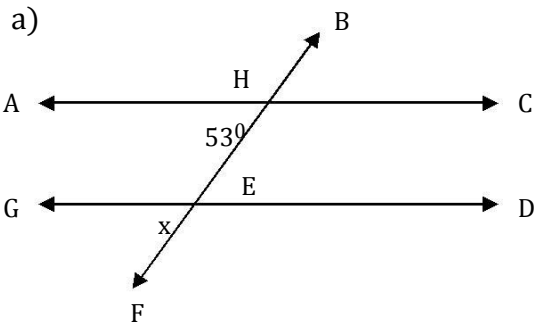

2-7 Polygon Theorems:

Key Concepts

Polygon: a closed figure that is a union of 3 or more line segments in a plane.

Sum of Interior Angles of a Polygon: the interior angles of any polygon is given by the expression:
$$S = 180(n - 2)$$

Sum of Exterior Angles of a Polygon: the exterior angles of any polygon is 360° .

1. Find the measure of one interior angle in each regular polygon, to the *nearest degree*.

a)

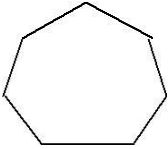

b) regular 15-sided polygon

2. Find the measure of one exterior angle in each regular polygon.

a)

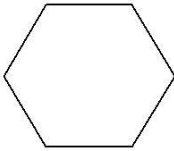

b) regular 13-sided polygon

3. Find the value of each missing angle.

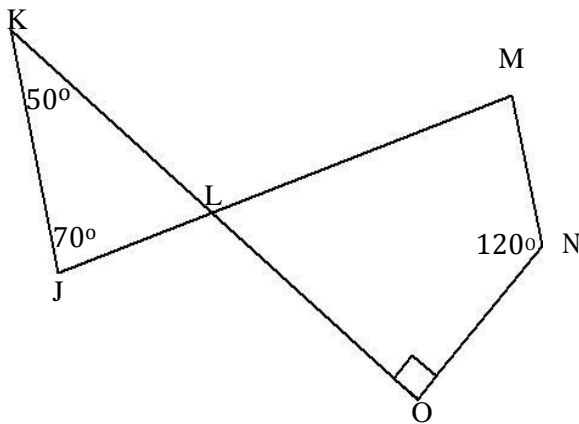

4. Find the value of each missing angle.

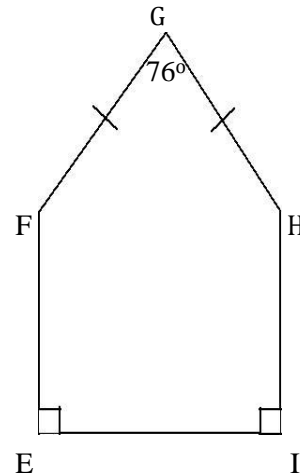

Re-test

1. In the figure below, AB is parallel to CD.

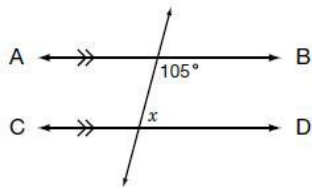

What is the value of x ?

- a 75°
- b 85°
- c 95°
- d 105°

2. AD is the angle bisector of $\angle BAC$.
 $\angle ABD = 57^\circ$ and $\angle ADC = 80^\circ$. What is the value of x ?

- a 50°
- b 57°
- c 70°
- d 77°

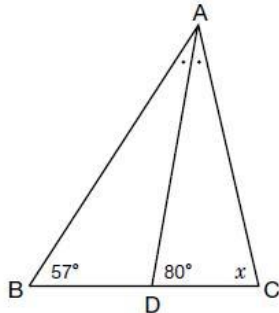

3. The frame of a picture measures 60 cm by 30 cm. The border around the picture is 10 wide.

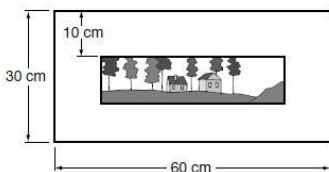

What are the dimensions of the **picture**?

- a 40 cm x 10 cm
- b 50 cm x 20 cm
- c 50 cm x 30 cm
- d 60 cm x 30 cm

4. Pat draws this figure.

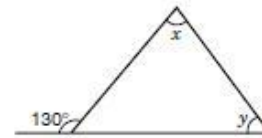

What is the relationship between the angles in this diagram?

- a $y = x$
- b $y = x + 50^\circ$
- c $x + y = 50^\circ$
- d $x + y = 130^\circ$

5. Each side of a cube is $2y$ cm long. What is the volume of the cube?

- a $8y^3 \text{ cm}^3$
- b $6y \text{ cm}^3$
- c $4y^3 \text{ cm}^3$
- d $2y \text{ cm}^3$

6. Yin measures a solid cylinder and a solid cone and finds that the solids have the same height and the same base diameter. Which of the following statements is true?

- a The volume of the cylinder is equal to three times the volume of the cone.
- b The total surface areas of the cylinder and cone are the same.
- c The volumes of the cylinder and cone are the same.
- d The total surface area of the cylinder is equal to three times the total surface area of the cone.

Answers

EQA0 Multiple Choice

1. A 2. C 3. D 4. B 5. B
6. B 7. B 8. C 9. 41 cm^2 10. $x = 60^\circ, y = 133^\circ$

2-1 Pythagorean Theorem

1. a) 7.6 cm b) 12.2 cm c) 9.3 mm d) 5.9 m
2. 127.3 ft 3. 8.5 miles 4. 60 inches

2-2 Optimization

1. 45 m by 45 m 2. 64 feet 3. 48 m
4. Circle 5. 225 ft by 450 ft; $101,250 \text{ ft}^2$

2-3 Composite Figures

1. a) Area: 109.1 m^2 ; Perimeter: 41.7 m b) Area: 49.5 cm^2 ; Perimeter: 33.8 cm
2. Emily runs 62.8 m farther 3. a) 39.5 cm^2 b) 24 cans of paint

2-4 Surface Area & Volume

1. a) 88.0 mi^3 2. a) 314.2 in^3
b) 484.0 cm^3 b) 210.0 cm^3
c) 8.0 mi^3 c) 18 ft^3
3. a) 56.5 cm^2 4. a) 659.7 km^3
b) 1082.4 in^2 b) 144 km^2
c) 2944 in^2 c) 266.0 yd^2
1354820.34
5. ft^2 6. 80 ft^3
7. 9 times 8. 4449 cm^2

2-5 Angles and Triangle Theorems

1. a) $a = 55^\circ, b = 85^\circ, c = 92^\circ$ 2. a) $x = 36$; $\angle \text{NOM} = 108^\circ, \angle \text{ONM} = 36^\circ$
b) $a = 57^\circ, b = 123^\circ, c = 32^\circ$
b) $x = 22$; $\angle \text{ABC} = 110^\circ, \angle \text{BAD} = 64^\circ, \angle \text{ADB} = 46^\circ$
3. $\angle \text{AFC} = 121^\circ, \angle \text{CBE} = 131^\circ, \angle \text{EDA} = 108^\circ, \angle \text{CFD} = 59^\circ, \angle \text{ADB} = 72^\circ, \angle \text{EBG} = 49^\circ$

2-6 Parallel Line Theorems

1. a) $\angle \text{GEF} = 53^\circ$ d) $x = 10$; $\angle \text{AHF} = 60^\circ, \angle \text{GEF} = 60^\circ$
b) $x = 8^\circ$; $\angle \text{PTV} = 8^\circ$ e) $x = -9$; $\angle \text{AHF} = 100^\circ, \angle \text{GEB} = 80^\circ$
c) $x = 9$; $\angle \text{STV} = 125^\circ, \angle \text{WXY} = 125^\circ$ f) $x = 18$; $\angle \text{NOP} = 120^\circ, \angle \text{POS} = 60^\circ,$
 $\angle \text{QRS} = 60^\circ$

2-7 Polygon Theorems

1. a) 128° b) 156° 2. a) 60° b) 27.7°
3. $\angle \text{KLJ} = 60^\circ, \angle \text{MLO} = 60^\circ, \angle \text{LMN} = 90^\circ$ 4. $\angle \text{GFE} = 142^\circ, \angle \text{IHG} = 142^\circ$

Re-test

1. D 2. D 3. D 4. B 5. C 6. D

Strand 3:

Analytical Geometry & Linear Relations

EQAO Sample Questions:

1. What are the slope, m , and y -intercept, b , of the line represented by: $3x - 2y + 16 = 0$?

a $m = \frac{3}{2}, b = 8$

b $m = \frac{2}{3}, b = -16$

c $m = -\frac{2}{3}, b = -8$

d $m = -\frac{3}{2}, b = 16$

See 3-2

2. Tyler walks along a line leading from a motion sensor. The graph below shows information about Tyler's walk. Which of the following is closest to Tyler's speed in metres per second as he walks toward the motion sensor?

- a 2.0
b 1.3
c 0.8
d 0.5

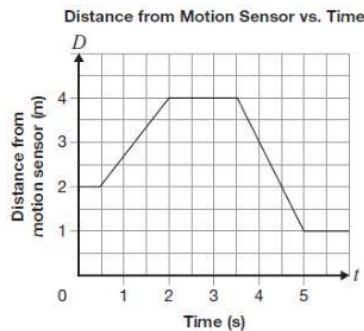

See 3-2

3. Consider the following graph.

Which statement is **false**?

- a The slope of AB is -2.
b The slope of CD is 1.
c The y -intercept of the line through CD is -4
d The y -intercept of the line through AB is -1.

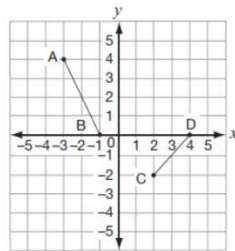

See 3-2

4. A bus is rented for a class field trip. The transportation cost for the trip is made up of \$225 to rent the bus, \$50 for gas and \$2 for each bus seat. Which relation below describes the total transportation cost for the trip if C is the total cost in dollars and n is the number of seats?

a $C = -2n + 225$

b $C = -2n + 275$

c $C = 2n + 225$

d $C = 2n + 275$

See 3-4

5. Consider the following chart and graph.

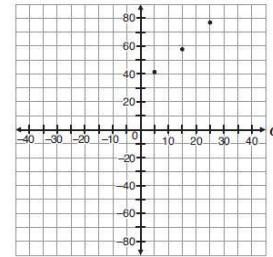

What temperature in degrees Celsius is equivalent to -20°F ?

- a -4°C
b -18°C
c -29°C
d -40°C

Temperature in degrees Celsius, C	Temperature in degrees Fahrenheit, F
5°	41°
15°	59°
25°	77°

See 3-2

6. A sports company uses the equation

$C = 8t + 5$ to represent the relationship between the total amount charged to rent a canoe, C , in dollars and the rental time, t , in hours. What is the initial charge to rent a canoe?

- a \$0
b \$5
c \$8
d \$13

See 3-2

7. The total cost of hiring Beth's Plumbing Services is represented by the equation $C = 50t + 70$, where C is the total cost in dollars and t is the time in hours. Next month, the rate will change to \$60 per hour, but the initial charge will stay the same. Which of the following describes how the graph of the relation will change?
- a The steepness of the line will increase
 - b The steepness of the line will decrease
 - c The vertical intercept will increase by 10 units
 - d The vertical intercept will decrease by 10 units

See 3-1

8. Janelle draws a line that passes through the points $(-1,6)$ and $(0,3)$. If Janelle writes the equation of the line in

$y = mx + b$ form, what are the values of m and b ?

- a $m = -9, b = 3$
- b $m = -3, b = 6$
- c $m = -9, b = 6$
- d $m = -3, b = 3$

See 3-2

9. **What's the Charge?**

The table below represents the linear relationship between cost and repair time at an appliance store.

Repair time, t (h)	Cost, C (\$)
3	205
6	385
8	505

Determine initial value of this relationship. Show your work

Initial value: _____

Is this relationship a direct or partial variation? Justify your answer.

See 3-2

10. **The New Line**

A line has

- The same slope as the line represented by $4x - 3y + 15 = 0$
 - The same y -intercept as the line represented by $2x + y + 6 = 0$
- Determine an equation of this line. Show your work.

See 3-4

3-1 Linear vs. Non-linear

Key Concepts

Linear Equation: an equation where the x -values increase at the same rate as the y -values in a graph: a straight line is used.

in a table of values: the first differences are constant. in an equation: the highest degree is one.

Non-linear Equation: an equation where the x -values increase at a different rate than the y -values. in a graph: a curve is used.

in a table of values: the first differences are not constant.

in an equation: the highest degree is anything other than one or zero.

1. Identify the relationships below as being linear or non-linear.

a)



Figure 1



Figure 2

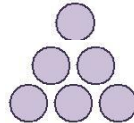

Figure 3

b)



Figure 1



Figure 2



Figure 3

2. Identify which table of values below is linear.

x	y
0	1
1	3
2	5
3	7
4	9

x	y
-5	0.25
-4	0.50
-3	1
-2	2
-1	4

x	y
-1	2
1	4
3	8
5	16
7	32

3. Identify which graphs below are linear.

a)

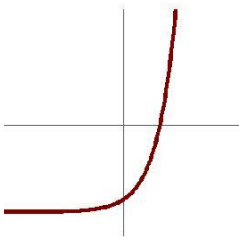

b)

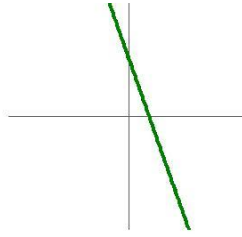

c)

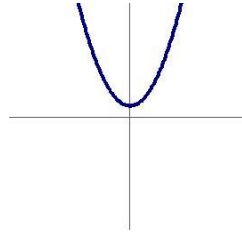

d)



4. Identify the following equations as being linear or non-linear.

a) $3x + 2y = 7$

b) $xy + 4 = 1$

c) $\frac{3}{x} = y$

d) $x^2 - 3x + 4 = y$

e) $y - x = 2$

f) $9x - 2 = \frac{y}{2}$

3-2 Forms of Representing Linear Equations:

Key Concepts

Slope-intercept form: $y = mx + b$, where m represents the slope and b represents the y-intercept.

Standard Form: $Ax + By + C = 0$

Slope: is the measure of how steep a line is. The slope can be calculated from:

- a graph: by determining the rise and run $m = \frac{\text{rise}}{\text{run}}$

- two points: using their coordinates $m = \frac{y_2 - y_1}{x_2 - x_1}$

y-intercept: the point where the line passes through the y-axis.

1. Write the following equations in slope-intercept form.

a) $3x - 2y = -16$

d) $x - 3y = 6$

b) $13x - 11y = -12$

e) $6x + 5y = -15$

c) $9x - 7y = -7$

f) $4x - y = 1$

2. Write the following equations in standard form.

a) $y = \frac{11}{4}x - 8$

d) $2y = -\frac{1}{3}x - \frac{3}{4}$

b) $y = -24x + \frac{6}{5}$

e) $y = -\frac{8}{15}x + \frac{1}{20}$

c) $y = -\frac{7}{3}x + 5$

f) $y = \frac{5}{6}x - 7$

3. Find the slope and y-intercept from the following graphs.

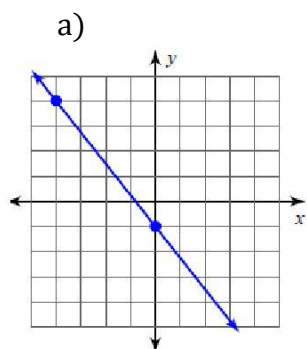

$m = \underline{\quad} b = \underline{\quad}$

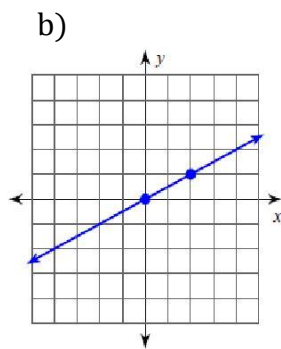

$m = \underline{\quad} b = \underline{\quad}$

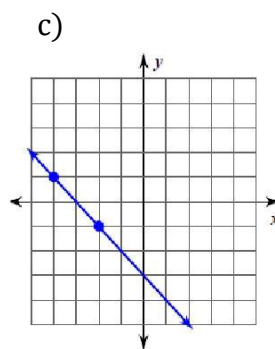

$m = \underline{\quad} b = \underline{\quad}$

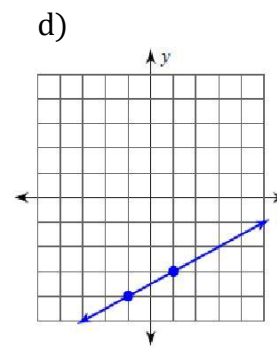

$m = \underline{\quad} b = \underline{\quad}$

3-3 Methods of Graphing:

Key Concepts

Table of Values: plot 5 points on the graph and connect them with a straight line.

Slope & y-intercept: plot the “ b ” value on the y -axis. Use the “ m ” value to determine the slope from that point, rise up if a positive slope or down if a negative slope and over to the right.

x & y -intercepts: calculate the x -intercept by subbing in $y = 0$ then calculate the y -intercept by subbing in $x = 0$. Plot these two intercepts and connect them with a straight line.

1. Graph the linear equation using the table of values below.

x	$y = -\frac{1}{3}x + 2$

x	$y = \frac{3}{2}x - 6$

x	$3y = x - 4$

2. Graph the following linear equations using the slope and y -intercept.

a) $y = 4x + 3$

d) $y = -3x - 3$

b) $y = \frac{4}{3}x - 4$

e) $y = \frac{3}{5}x + 1$

c) $y = x + 1$

f) $y = -x + 2$

3. Graph the following linear equations using the x and y -intercepts.

a) $4x - 2y = 6$

d) $-8x + 4y = -16$

b) $-6x + \frac{3}{4}y = 9$

e) $-\frac{3}{4}x - \frac{1}{2}y = 3$

c) $-x + 3y = 9$

f) $2x + 5y = 12$

3-4 Generating an Equation:

Key Concepts

Given two points: first calculate the slope, then find the y-intercept by subbing in one of the points.

Given a word description: determine whether the new slope is parallel or perpendicular to the existing slope.

Given a graph: calculate the slope using the rise and the run, then read the y-intercept from the graph.

- Write an equation that satisfies the information given below.
 - Passes through (3, -1) and (10, 5)
 - Passes through (1, 2) and (-2, 5)
 - Passes through (2, -4) and (4, -8)
 - Passes through (0, -4) and (2, 0)
- Write an equation that passes through (-1, 4), and parallel to $y = -5x + 2$.
- Write an equation that passes through the point (-1, 2) and is perpendicular to $y = \frac{1}{4}x + 5$
- Write an equation that is parallel to $3x + 6y = 7$ and has the same x-intercept as $y = -2x + 4$
- Write an equation for the linear equations shown below in slope y-intercept form.

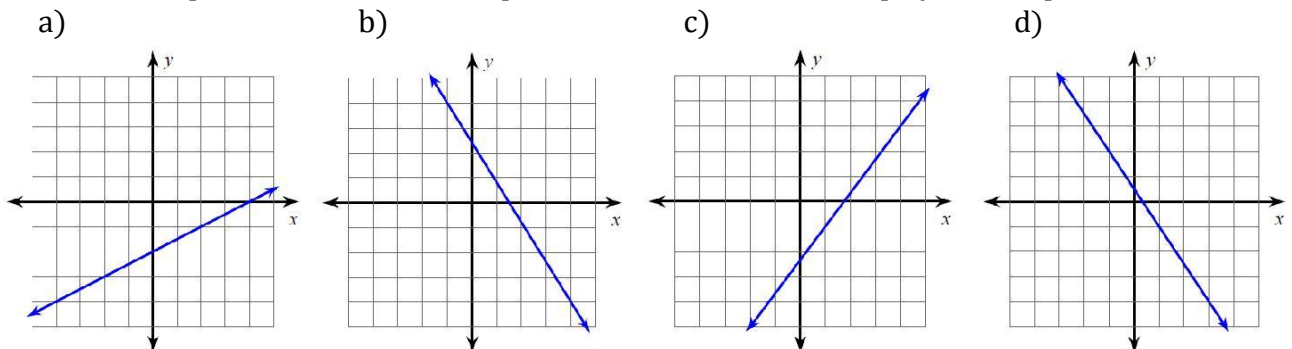

3-5 Special Lines:

Key Concepts

Horizontal Lines: lines that are parallel to the x-axis and have a slope of 0.

Vertical Lines: lines that are parallel to the y-axis and have an undefined slope.

Remember: **H**orizontal

O slope

Y = b

Vertical

Undefined slope

X = a

1. Graph the following horizontal lines.

a) $y = -1$

b) $y = -4$

c) $y = 8$

d) $y = 7$

2. Graph the following horizontal lines.

a) $x = 2$

b) $x = -5$

c) $x = -3$

d) $x = 6$

3. Make a sketch of the horizontal line that passes through the point given below. What is the equation of this line?

a) (3, -4)

b) (-7, 3)

c) (0, 5)

d) (-2, 6)

4. Make a sketch of the vertical line that passes through the point given below. What is the equation of this line?

a) (-5, 4)

b) (5, 7)

c) (-4, -8)

d) (8, -2)

5. Write the equation for the line that is perpendicular to each of the lines in #4.

3-6 Linear Systems:

Key Concepts

Linear System: two or more linear equations considered at the same time.

Solution: the point where the two linear equations intersect.

1. Solve each system graphically.

a) $y = -\frac{5}{3}x + 3$

c) $y = -\frac{1}{2}x - 1$

e) $y = 3x - 4$

g) $y = -\frac{1}{2}x - 2$

$y = -\frac{1}{2}x + 3$

$y = \frac{1}{3}x - 3$

$y = \frac{1}{4}x - 4$

$y = -\frac{3}{2}x + 2$

b) $y = 4x + 3$

d) $y = -1$

f) $y = -2x + 2$

h) $y = \frac{1}{3}x - 3$

$y = -x - 2$

$y = -\frac{5}{2}x + 4$

$y = -2x - 2$

$y = -x + 1$

2. Jack and Liam just had business cards made. Jack's printing company charged a one-time setup fee of \$20 and then \$4 per box of cards. Liam ordered his cards online. They cost \$5 per box. There was no setup fee, but he had to pay an additional \$10 to have them shipped to his house. After purchasing how many boxes, would Jack and Liam end up spending the same amount?
3. Paula and Megan each regularly buy books at Chapters. Paula decided to buy the store discount card which cost \$50 initially but saves her \$2 a book for the entire year. Each book the girls bought was \$20. Who made the smarter decision?

3-7 Scatter Plots & Lines of Best Fit:

Key Concepts

Scatter Plot: a graphical method of showing the relationship between two variables.

Partial variation: the dependent variable is related to the independent variable; the y-intercept is not zero.

Direct variation: the dependent variable is directly related to the independent variable; the y-intercept is zero.

Correlation: a relationship between the dependent and independent variable. Can be classified as: **positive, negative, no correlation.**

Strength of Correlation:

Perfect correlation: all points lie on the line of best fit

Strong correlation: points are close to the line or best fit

Moderate correlation: points are spread out but there is a definite trend

Weak correlation: points are more spread out and trend is less obvious

Line of Best Fit: a line that follows the trend of the data and has the same number of points above and below the line.

Interpolation: method of prediction that reads information within the given range of data.

Extrapolation: method of prediction that requires the line of best fit to be extended to read information outside of the given range of data.

1. Describe the relationship between the two variables.

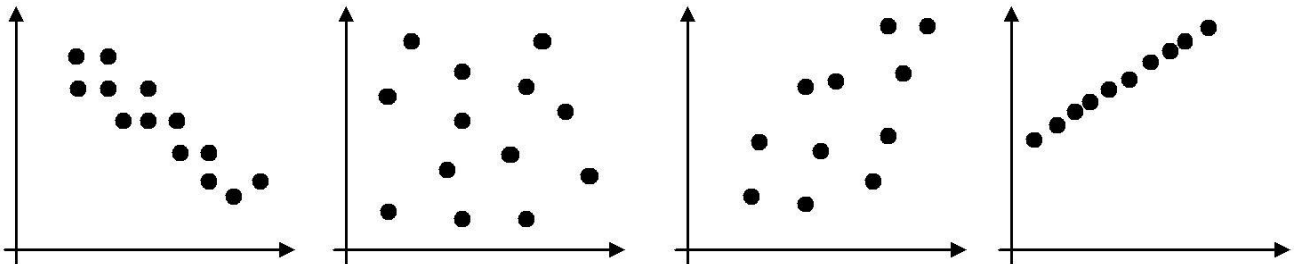

2. Describe the relationship between the following:
- a) Your average mark in school and the amount of time spent in front of the television
 - b) Your shoe size and your score playing angry birds
 - c) Freeze sales and the temperature outside
 - d) The weight in your backpack and your level of back pain
3. A tree trunk's diameter was measured over the course of its life. The data is found in the table below.

Age (years)	10	20	30	40	50	60	70	80	90
Diameter (cm)	15	25	40	53	65	80	90	102	115

Create a scatter plot and draw in the line of best fit.

What was the diameter of the tree trunk after 7 years? What method was used to determine this? What will diameter of the tree trunk be when it is 65 years old? What method was used to determine this?

Re-test

1. The graph below represents the relationship between distance and time on

Javier's walk.

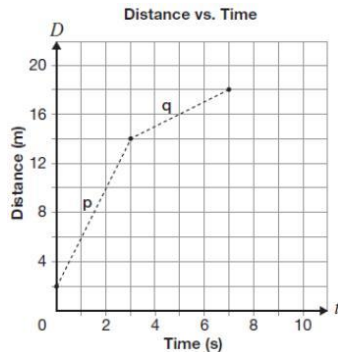

How much greater is Javier's speed in section p than in section q ?

- a 0.5 m/s
 b 1.5 m/s
 c 2.0 m/s
 d 3.0 m/s
2. Which of the following represents an equation of a line?
 a $y = 2^x$
 b $y = x^2 - 5$
 c $x^2 + y^2 - 25 = 0$
 d $2x + 3y - 5 = 0$

3. For the slope of the line, the change in x is greater than the change in y . Which of the following could represent the slope of this line?

- a $\frac{4}{3}$
 b 2
 c 1
 d $\frac{2}{5}$

4. Data on distance travelled and the number of hours spent travelling are shown on the graph below. The line

$D = 10n + 30$ is also shown on the graph.

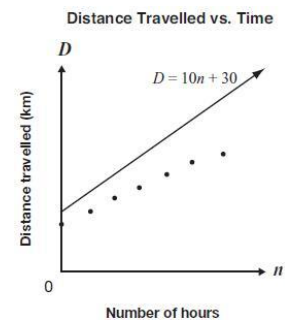

Which equation best represents the line of best fit for the data shown?

- a $D = 5n + 33$
 b $D = 8n + 23$
 c $D = 10n + 18$
 d $D = 12n + 25$
5. The table of values below displays the cost of renting a bicycle. Which equation models the cost of renting a bicycle

- a $c = 5t$
 b $c = 25t$
 c $c = 5t + 25$
 d $c = 25t + 5$

Time, t (h)	Cost, C (\$)
0	25
1	30
2	35
3	40

6. Which of the following statements is true for the line $5x - 2y - 12 = 0$

- a The slope is $\frac{2}{5}$ and the y-intercept is 12
 b The slope is -5 and the y-intercept is 6
 c The slope is 5 and the y-intercept is -12
 d The slope is $\frac{5}{2}$ and the y-intercept is -6

Answers

EQAO Multiple Choice

1. A 2. A 3. D 4. D 5. C
 6. B 7. A 8. D 9. \$25; partial 10. $y = \frac{4}{3}x - 6$

3-1 Linear vs. Non-linear

1. a) non-linear b) linear
 2. first table only 3. b) and d)
 4. a) linear b) non-linear c) non-linear d) non-linear e) linear f) linear

3-2 Forms of Representing Linear Equations

1. a) $y = \frac{3}{2}x + 8$ c) $y = \frac{9}{7}x + 1$ e) $y = -\frac{6}{5}x - 3$
 b) $y = \frac{13}{11}x + \frac{12}{11}$ d) $y = -\frac{1}{6}x - 2$ f) $y = 4x - 1$
2. a) $11x - 4y = 32$ c) $7x + 3y = 15$ e) $32x + 60y = 15$
 b) $120x + 5y = 6$ d) $4x + 24y = -9$ f) $5x - 6y = 42$
3. a) $m = -\frac{5}{4}, b = 4$ c) $m = -1, b = -3$
 b) $m = \frac{1}{2}, b = 0$ d) $m = \frac{1}{2}, b = \frac{7}{2}$
 b) $m = 2, b = 0$ d) $m = 2, b = 2$

3-3 Methods of Graphing

1.

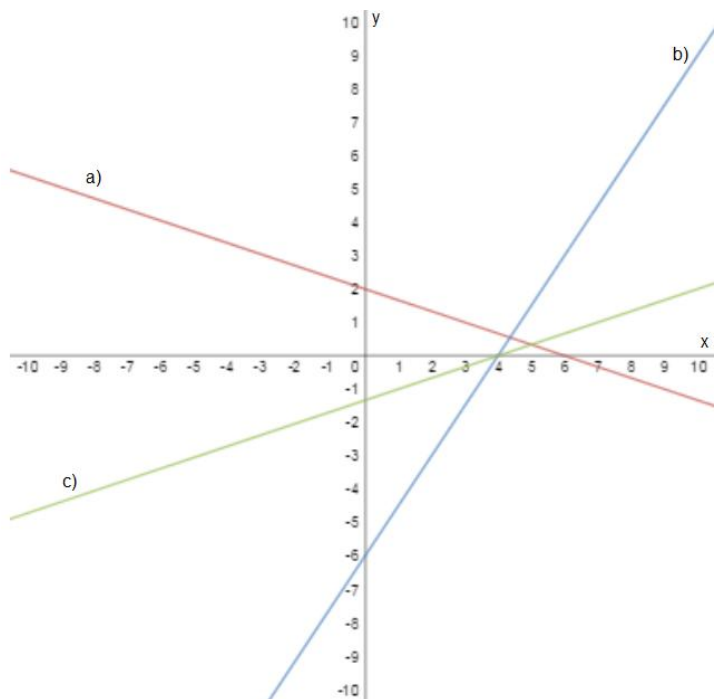

2. a)

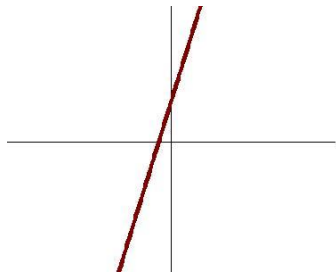

b)

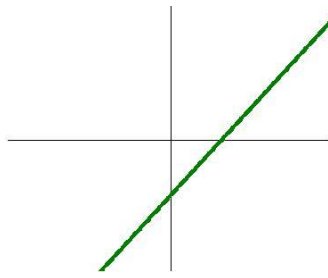

c)

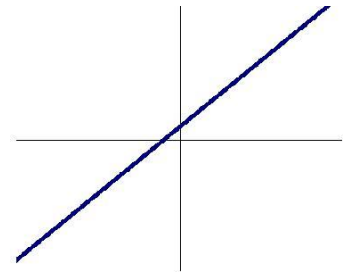

d)

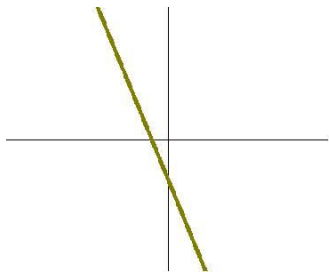

e)

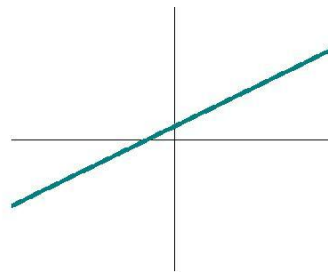

f)

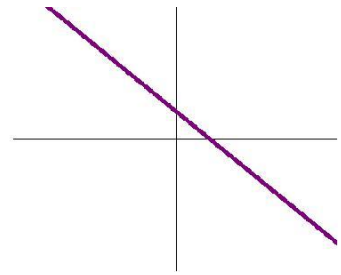

3.

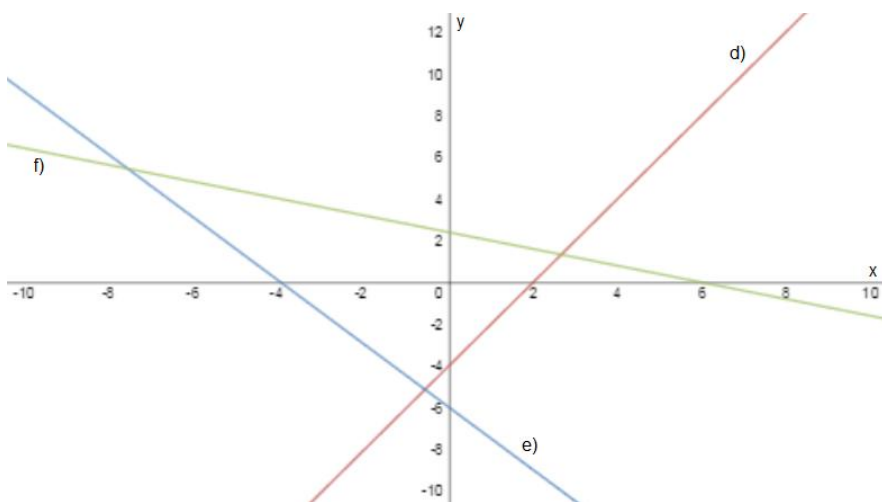
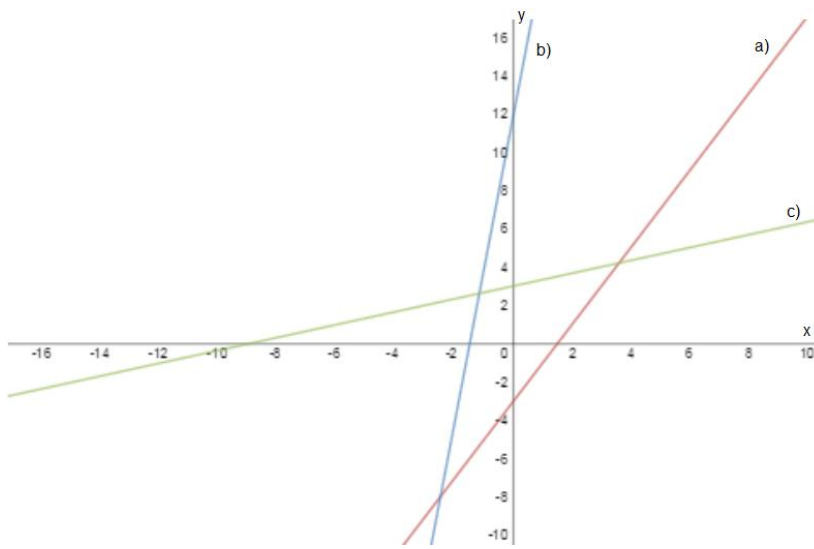

3-4 Generating an Equation

1. a) $y = \frac{6}{7}x - \frac{25}{7}$ b) $y = -x + 3$ c) $y = -2x$ d) $y = 2x - 4$
2. $y = -5x + \frac{4}{5}$ 3. $y = -4x + 7$ 4. $y = -\frac{1}{2}x + 1$
5. a) $y = \frac{1}{2}x - 2$ b) $y = -\frac{8}{5}x + \frac{5}{2}$ c) $y = \frac{4}{3}x - \frac{7}{3}$ d) $y = -\frac{3}{2}x + \frac{1}{2}$

3-5 Special Lines

3. a) $y = -4$ b) $y = 3$ c) $y = 5$ d) $y = 6$
4. a) $x = -5$ b) $x = 5$ c) $x = -4$ d) $x = 8$
5. a) $y = 4$ b) $y = 7$ c) $y = -8$ d) $y = 2$

3-6 Linear Systems

1. a) (3, -2) c) (4, -3) e) (2, 2) g) (4, -4)
b) (-1, -1) d) (2, -1) f) no solution h) (3, -2)
2. 10 boxes

3. If you buy less than 15 books, Megan made the better decision, if you buy exactly 15 books, either girl made a good decision, if you buy more than 15 books, Paula made the better decision.

3-7 Scatter Plots & Lines of Best Fit

1. a) linear, strong, negative correlation c) linear, weak, positive correlation
b) no correlation d) correlation
2. a) as the time spent in front of the tv increases, the average mark decreases
b) no relationship
c) as the temperature increases, the freeze sales increase
d) as the weight in your backpack increases, the higher level of back pain
3. 13 cm, extrapolation; 87 cm, interpolation

Re-test

1. D 2. D 3. D 4. B 5. C 6. D