

Ergo Tools



lighting
laptop holders
cpu holders
document holders
foot rests
glare filters
input devices



TXMAS Price Guide

Texas Multiple Award Schedules

Office Products and Services and New Products Technology

Ergo Tools Contract: TXMAS-3-7511A010

Contract Period: 04/01/03 through 03/15/2012

Ordering Address: Humanscale

Contractor Address: 2651 N. Harwood, Suite 108, Dallas, TX 75201

Contact Number: 214-965-9232 Fax: 214-299-9349

Email Address: dallastxmas@humanscale.com

Web Site Access: <http://portal.cpa.state.tx.us/txmas>

Table of Contents

Keyboard System Accessories.....	3
Ergonomic Accessories	4
Build Your Different Light Product Code	7
Terms & Conditions.....	9

TXMAS DISCOUNT ON ALL KEYBOARD PRODUCTS

END USER LIST

DISCOUNT

FROM DOLLAR ONE (\$1).....63%

Note: All prices are list. Use applicable TXMAS discount to calculate TXMAS pricing.

Keyboard System Accessories

Mouse Pads



HSMP12TIPS \$5

8" 12 Tips Ergo Mouse Pad

HSMP12TIPS10 \$6

9" 12 Tips Ergo Mouse Pad

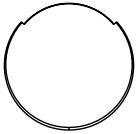

CMPGEL8 \$26

8.5" Gel Mouse Pad

For 90 or 90H Clip Mouse

CMPGEL \$26

10" Gel Mouse Pad

For 91 or 91H Clip Mouse

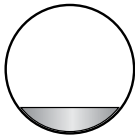

MPGEL8 \$21

8.5" Gel Mouse Pad

MPGEL10 \$26

10" Gel Mouse Pad

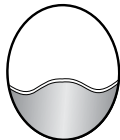

GPSMP \$37

Desktop Mouse Pad with Gel Palm

Palm Support

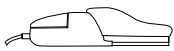

MM10 \$16

Mouse Mate



GPS \$43

Desktop Gel Palm Support

Corner Sleeves

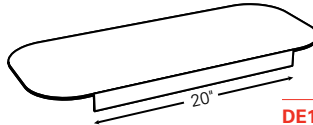

DE100 \$128

29.5" x 12.188"

Fits desks 1" to 1.5" thick

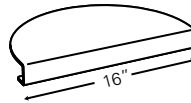

DE200/DE250 \$81

16" diameter

DE200 fits desks 1" to 1.5" thick

DE250 fits desks 1.5" to 2.5" thick

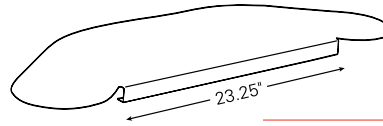

DE400/DE450 \$209

38.5" x 13.75"

DE400 fits desks 1" to 1.5" thick

DE450 fits desks 1.5" to 2.5" thick

TXMAS DISCOUNT ON ALL ERGO TOOLS

END USER LIST

FROM DOLLAR ONE (\$1).....65%

DISCOUNT

Note: All prices are list. Use applicable TXMAS discount to calculate TXMAS pricing.

Ergonomic Accessories

Input Device



Switch Mouse

SMUSB

\$120

Switch Mouse with USB connector, optical sensor and navigation dish

Laptop Holders

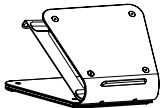

L2

Notebook Manager

\$213

Maximum Dimensions:
10" d x 10.5" w x 8.75" h
5" height adjustability

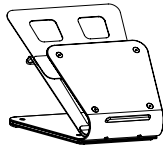

L2DS

Notebook Manager with Docking Station Support

\$240

L2DSEXT

Retrofit Docking Station Support

\$32

Foot Rests

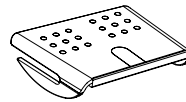

Rocking Foot Machine

FM500C (Cherry)

\$152

FM500K (Black)

\$152

12.25" d x 16.75" w x 4.5" h



Foot Machine with Massage Balls

FM300B (Natural)

\$180

FM300BDC (Dark Cherry)

\$180

11.875" d x 16" w

Height Range: 3.75" to 6.75"

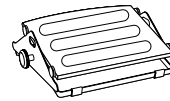

Foot Machine

FM300 (Natural)

\$135

11.875" d x 16" w

Height Range: 3.75" to 6.75"



Tilting Foot Rest

FM100 (Natural)

\$125

11.75" d x 19" w x 3.375" h

TXMAS DISCOUNT ON ALL ERGO TOOLS

END USER LIST

DISCOUNT

FROM DOLLAR ONE (\$1).....65%

Note: All prices are list. Use applicable TXMAS discount to calculate TXMAS pricing.

Ergonomic Accessories

CPU Holders

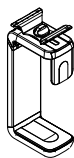

CPU600 \$168

Fits CPUs 3.5" to 9" wide by 12" to 20" high Max CPU Weight: 50 lbs.

Installed Dimensions:
7" or CPU Width + 1.7" (whichever is greater), CPU Height + 3.6"

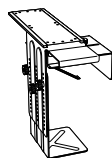

CPU300 \$142

Fits CPUs 3.25" to 9" wide by 10.5" to 18" high
Max CPU Weight: 70 lbs.

Installed Dimensions:
CPU Width + 1.5"; CPU Height + 3"

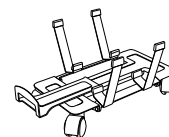

CPU Dolly

CPUDLY \$153

Fits CPUs 3.25" to 9" wide

Installed Dimensions:
CPU Height + 3.75"

CPUDLYPLT \$164

With Platform
For CPUs 1.5" to 9" wide

CPUPLATFORM \$17

CPU Dolly Retrofit Platform

CPUDLYH \$38

Telescoping Pull Handle

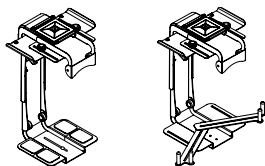

CPU555 \$164

Fits CPUs 3" to 9.5" wide
by 12" to 22" high
Max CPU Weight: 70 lbs.

Installed Dimensions:
CPU Width + 3.5"; CPU Height + 4.5"

CPU555SEC \$196

With Security System

CPU555STOOL \$27

Replacement Tool Kit for CPU555SEC
(comes standard with CPU555SEC)

CPU555SECKIT \$50

Retrofit Security Kit for CPU555
(comes standard with CPU555SEC)

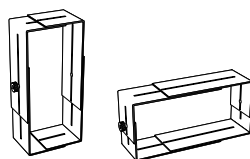

CPU450 \$131

Fits CPUs 4" to 8"
by 11.5" to 20"
Max CPU Weight: 50 lbs.

Installed Dimensions:
CPU Width + 2.5"; CPU Height + 3.75"

CPU450STK \$33

Swivel Track Upgrade Kit

Quick Track

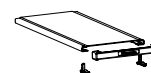

Quick Track

QT \$13

Easily removable (without tools) front
bracket makes swap-outs a snap.

To order, simply add "QT" to end of product
code (e.g., CPU555QT).

Comes standard with CPU600.

TXMAS DISCOUNT ON ALL ERGO TOOLS

END USER LIST

DISCOUNT

FROM DOLLAR ONE (\$1).....65%

Note: All prices are list. Use applicable TXMAS discount to calculate TXMAS pricing.

In-Line Document Holders

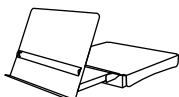

Copy Drawer

CH3000 (Putty) \$153
CH3000B (Black)* \$153
 15" d x 15.5" w x 3" h



Copy Stand

CH1000 (Putty) \$126
CH1000B (Black)* \$126
 12" d x 14" w x 3" h
 For use with CRTs



Copy Stand Basic

CH900 (Putty) \$110
CH900B (Black)* \$110
 11" d x 14" w x 3" h
 For use with flat panel monitors

* Black may require up to an 8–10 week lead time. See your Humanscale sales representative for more information.

Security Lock

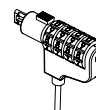

Security Lock

SECLOCK \$42
 For CPUs, laptops, flat panels, etc.
 Fits all units with standard security keyhole

Glare Filters

NOTE:

Filter fits size of monitor indicated by number in code.
 For example, FP15 fits 15" monitors.

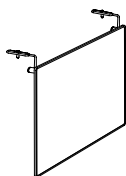

Flat Panel Filters

with Tempered Glass and
 95% Transmission (5% Tint)

Standard

FP15 14.25" w x 10.875" h \$126
FP17 14.625" w x 12.75" h \$218
FP19 15.75" w x 12.375" h \$246
FP20 17.125" w x 13" h \$263
FP21 18.125" w x 13.75" h \$273

Privacy

FP15PF 13.125" w x 10" h \$235
FP17PF 15" w x 11.5" h \$290
FP19PF 15.75" w x 12.375" h \$322
FP20PF 17.125" w x 13" h \$333
FP21PF 18.125" w x 13.75" h \$350

Ergo Block

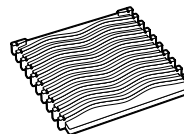

Ergo Block

EB025 (Gray) \$11
EB025B (Black)
 1" x 11.25" x 11.25"
 Stackable Riser
EB050 (Gray) \$14
EB050B (Black)
 2" x 11.25" x 11.25"
 Stackable Riser

TXMAS DISCOUNT ON ALL ERGO TOOLS

END USER LIST

DISCOUNT

FROM DOLLAR ONE (\$1).....65%

Note: All prices are list. Use applicable TXMAS discount to calculate TXMAS pricing.

Build Your Diffrient Light Product Code

To create the product code for your Diffrient Light, simply choose your preferred style, mount, color and bulb, and combine the respective codes for each.

Lighting Product Code:

Style	Mount	Color	Bulb
1	2	3	4
_____	_____	_____	_____

1 Style

DIFFRIENT TASK LIGHT (DT SERIES)

Compatible with 4-pin compact fluorescent bulbs.

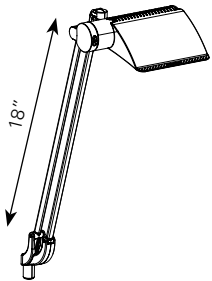

DT1E \$290
Single Arm with Task Shade

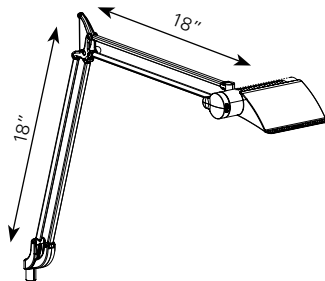

DT2E \$322
Double Arm with Task Shade

DIFFRIENT WORK LIGHT II (DX SERIES)

E26 socket compatible with screw-in bulbs up to 60W.

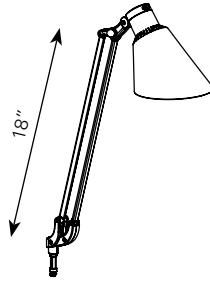

DX1E \$290
Single Arm with Work Shade

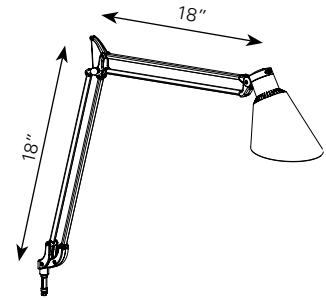

DX2E \$322
Double Arm with Work Shade

2 Mount

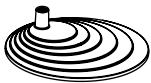

B Add \$90
Desktop Base
9" diameter

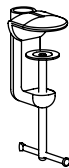

C N/C
Clamp
For grommet or edge mount. Fits surfaces up to 2" thick and grommet holes 2" or more in diameter.

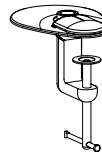

G Add \$10
Clamp with Grommet Cover
For grommet holes 2" – 3.25" in diameter.

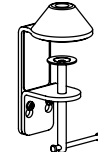

K Add \$15
2-Piece Clamp
Requires minimum 1/4" clearance between desk and wall or panel.

TXMAS DISCOUNT ON ALL ERGO TOOLS

END USER LIST

DISCOUNT

FROM DOLLAR ONE (\$1).....65%

Note: All prices are list. Use applicable TXMAS discount to calculate TXMAS pricing.

2 Mount, cont.

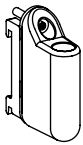

Panel Mount Add \$25

- PC** Allsteel Concensys
- P2** Allsteel Terrace 2.6 & 3.4, Align
- PH** Haworth Places, Unigroup
- PM** Haworth Premise
- PA** Herman Miller Action Office
- PE** Herman Miller Ethospace
- PR** Herman Miller Resolve
- P9** Steelcase 9000
- PB** Teknion Boulevard
- PI** Teknion IE
- PL** Teknion Leverage, Transit

Not compatible with corner mount applications. For other panel systems, see your Humanscale representative.

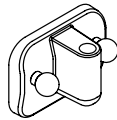

S N/C

Universal Slatwall
Adjusts to fit most standard slatwalls.



W N/C

Wall
Screws into vertical surface.



A N/C

Humanscale Access Rail



D N/C

Direct
Screws into horizontal surface.

3 Color

S
Silver

B
Black

4 Bulb

DIFFRIENT TASK LIGHT (DT SERIES)

— 26W, 3500K, 4-Pin Base N/C

DIFFRIENT WORK LIGHT II (DX SERIES)

1 18W, 3500K (standard) N/C
2 23W, 3500K N/C
0 No Bulb Less \$5

Diffrient Light Replacement Parts (if purchased separately)

MOUNTS

Desktop Base	DLBS (silver), DLBB (black)	\$125
Access Rail	DLAS (silver), DLAB (black)	\$35
Clamp <i>For grommet or edge mount</i>	DLCS (silver), DLCB (black)	\$35
2-Piece Clamp <i>For edge mount</i>	DLKS (silver), DLKB (black)	\$50
Direct	DLDS (silver), DLDB (black)	\$35
Universal Slatwall	DLSS (silver), DLSB (black)	\$35
Wall	DLWS (silver), DLWB (black)	\$35
Panel Mount	DL <u>1</u> <u>1</u> <u>2</u>	\$60
<small>(1): Panel System Code, (2): Color (B or S)</small>		
Grommet Cover <i>For use with Clamp Mount C</i>	DLGC (black)	\$10

TASK AND WORK LIGHT ACCESSORIES (DT AND DW SERIES)

Electronic Ballast	DLBALE (gray)	\$126
Magnetic Ballast	DLBALM (black)	\$100
Bulb <i>26W, 3500K, 4-Pin Base</i>	DLBULB	\$22

WORK LIGHT II ACCESSORIES (DX SERIES)

Bulb <i>18W, 3500K, screw-in base</i>	DLCFL1	<i>Consult your rep</i>
Bulb <i>23W, 3500K, screw-in base</i>	DLCFL2	<i>Consult your rep</i>

Humanscale Terms and Conditions

THE FOLLOWING TERMS & CONDITIONS APPLY TO ALL HUMANSCALE PRODUCTS.

TERMS OF PAYMENT

Upon approved credit, terms of payment are net 30 from date of shipment. Deposits may be required for large or custom orders. The processing of orders and/or shipment of orders placed may be delayed if the deposit is not received with the order or if customer's account is in "Past Due" status.

CREDIT POLICY

All customers of Humanscale must complete a credit application, with current information, which must be signed by an owner or officer. A line of credit may be set by our Credit Department, however the basis for the line of credit may be changed or cancelled at our discretion and advance payment may be required. Any unpaid balance, upon which payments are not made according to the terms governing the sale, will be considered "Past Due" and will increase by a maximum of 2% per month, without forfeit of Humanscale's right to payment.

Any customer who has failed to pay for goods delivered or services rendered in a timely manner shall be liable for all fees, expenses, disbursements, and charges (including all legal costs) incurred by Humanscale in collecting monies owed, as well as interest (at 24% per annum).

PURCHASE ORDERS

Purchase orders must include the following: "Bill To" and "Ship To" information—Company Name (Ship To company may be end user or installation company), Address, Telephone, Fax, Contact Person; End User Company Name; Requested Ship Date; Purchase Order Number; Special Delivery, Shipping and Packing Instructions (if applicable); Proper Discount Off Current List Price, Product Quantities and Full Model Numbers; and Total (List/Net).

ORDER CHANGES & CANCELLATIONS

All changes to or cancellations of orders placed with Humanscale must be in writing and sent to Customer Service. Orders may be changed or cancelled without penalty if Humanscale is notified at least two (2) weeks before the scheduled ship date. All order changes or cancellations made less than two (2) weeks before the scheduled ship date will incur a minimum change/cancellation fee of 10% of net. Irrespective of when notified, changes or cancellations are not binding upon Humanscale until Humanscale issues a written acknowledgment of the change or cancellation. Order changes are defined as the deletion of line items; changes in style, color, quantity or requested ship date; or ship-to address changes. Order changes that result in a quantity reduction may be subject to an additional small order fee or adjustment in pricing. Under no circumstances will changes or cancellations be accepted on any custom fabric, special order or custom product orders.

TAXES

Humanscale list prices do not include sales tax. Customer is responsible to remit all such tax. Humanscale requires a State Resale/Exemption Certification to be on file at its main office. Sales made without said Certificate will be charged the appropriate sales tax.

PRICES

All discounts and list prices are subject to change without notice. Prices are those in effect at the time of order entry. If the requested shipment date is more than 90 days after the order date, Humanscale reserves the right to price said order based on the published list price as of the shipment date.

SMALL ORDER FEE

A 3% small order fee applies to all invoiceable orders of \$1,500 net or less, including billable replacement parts, regardless of product category.

SHIPPING AND DELIVERY

All Humanscale orders are acknowledged with a promise date (scheduled ship date) based on the product with the longest lead time. Large orders may increase standard lead times. Standard shipping charges will be billed to customer. Custom platform orders require 4 to 6 weeks.

Seating orders, unless otherwise specified, will ship 4 to 6 weeks from the date of order. Unless otherwise contractually specified, Freedom and Liberty chairs will ship with the base and frame disassembled. Chairs can be easily assembled in seconds without use of tools. Blanket-wrapped shipping is available for full truckloads of 200 or more Freedom or Liberty Task and Conference chairs. Consult your Humanscale representative for blanket-wrapped shipping requirement for Cinto and the Liberty Side chair.

Ship Sets: All products ordered on a single purchase order will be delivered together in a single ship set. To break a ship set, customers must indicate "Ship as Available" on the purchase order. Upon request, customer accounts may be defaulted to ship all orders on an as-available basis.

Shipping Instructions: Humanscale will attempt to accommodate basic shipping instructions, such as "call ahead" or "deliver before 12:00 p.m.," if clearly identified on the purchase order as "Shipping Instructions."

Packing Instructions: Humanscale will attempt to accommodate basic packing instructions for internal delivery of specific items on an order, such as "Deliver to Joe Smith" or "Deliver to cube #218," if clearly identified on the purchase order as "Packing Instructions."

DELIVERY SHORTAGES

Product shortages must be noted at the time of delivery and reported to the carrier for correction. Claims against Humanscale for shortages, errors, etc., must be made in writing and within three (3) days of the date of delivery or customer waives its right to make such a claim.

FREIGHT CLAIMS

Humanscale will file all F.O.B. destination claims. In order to receive credit, customer agrees to cooperate and assist in the procedures set out by the carrier and Humanscale.

EXTERNAL DAMAGE

If the shipping container shows any external damage, customer is instructed to refuse the product at time of delivery. If it is a multiple piece shipment, customer may refuse only the damaged items. Humanscale will not issue full credit for returned product unless customer takes the following action steps:

1. Note damage on the delivery receipt at time of delivery.
2. Refuse product at time of delivery.
3. Contact Humanscale Customer Service within 24 hours of the attempted delivery and advise them of the damage.
4. Enter a chargeable replacement order; credit will be issued after the disposition of damaged product is determined.

CONCEALED DAMAGE/LOSS

If customer determines that there is internal damage not visible at time of delivery, customer will retain all packaging materials and take the following action steps within fifteen (15) calendar days from the date of delivery:

1. Request inspection by calling local freight carrier to report damage.
2. Retain merchandise in the original box.
3. Call your Humanscale Customer Service agent to provide order and product information.
4. Get a copy of the inspection report from carrier.
5. Enter a chargeable replacement order; credit will be issued after the disposition of damaged product is determined.

STORAGE

If a customer is unable to accept a scheduled product delivery, Humanscale, if notified in writing after product assembly and prior to the scheduled ship date, will store the product at customer’s expense. Humanscale shall invoice customer for the product and monthly Storage Fees.

Storage Fees will be 1% of the net order value per month or actual storage costs—whichever is greater. Storage Fees are calculated with a one-month minimum and will not be pro-rated. If customer is unable to accept a scheduled product upon delivery, customer shall be responsible for placing the product in storage and bears the risk of loss. However, payment of the balance due is per Humanscale’s Terms of Payment.

RETURN AUTHORIZATIONS & REFUSALS

All returned and non-damaged refused orders are subject to a twenty percent (20%) restocking fee. Seating and special order returns will not be accepted. Customer must request a Return Authorization through the Humanscale Customer Service Department within 45 days of product receipt to return any product. If Humanscale agrees to restock the product, customer must return it freight prepaid to Humanscale, F.O.B., to the original shipping point or as otherwise instructed by Humanscale Customer Service. If product is returned without a Return Authorization, Humanscale will notify customer of the unauthorized return and customer must provide instructions for its disposition within one week thereafter. Failure of customer to respond within one week will result in Humanscale’s right to dispose of the product with no credit. Return Authorizations expire sixty (60) days after the date of issue. If the returned product is not in resalable condition, customer will not receive credit for the return. Customer must promptly provide a purchase order or other acceptance of fees/credit reduction as required.

WARRANTY

THE FOLLOWING WARRANTY IS IN LIEU OF ALL OTHER WARRANTIES EXPRESS OR IMPLIED, INCLUDING, BUT NOT LIMITED TO, THE IMPLIED WARRANTY OF MERCHANTABILITY AND FITNESS FOR A PARTICULAR PURPOSE AND ALL OTHER WARRANTIES ARISING FROM COURSE OF DEALING OR USAGE OF TRADE.

Humanscale offers the following warranties on its products:

PRODUCT	WARRANTY
Light Bulbs Customer’s Own Material (COM, COL)	No Warranty
Switch Mouse	1 Year
Diffrient Light Fabric/Cushions	5 Years
M4 & M7 Monitor Arms with Gas Cylinder Components	10 Years
All Other Products, Detailed in a Current Price Guide	15 Years
All Other Products, Not Detailed in a Current Price Guide	Varies; consult your Humanscale rep for details

This Warranty is applicable to the initial purchaser only and is non-transferable. If products are procured through authorized Humanscale Dealerships, the end-user customer must be registered with Humanscale for the warranty to be in effect. Humanscale warrants that, at the time of customer’s receipt, the product will be in good working order and will be free from defects in material and workmanship. This Warranty does not apply to normal wear and tear or damage caused by accident, neglect, misuse or improper installation or operation. Humanscale will not be responsible for damage due to service, maintenance, modifications or tampering by anyone other than a Humanscale authorized representative. In the event a product is defective and Humanscale receives written notice of the defect within the Warranty period, Humanscale, at its option, will either repair or replace the defective product. This Warranty does not cover damage caused by a carrier or transportation of the product from one location to another, or alterations made by owner.

LIMITATION OF LIABILITY

Purchaser’s remedies set forth herein are exclusive and the liability of Humanscale with respect to the breach of this agreement or any contract entered into between the parties pursuant hereto shall not exceed the price of the product or part on which such liability is based. In no event will Humanscale be liable to purchasers for any special, collateral, incidental or consequential damages however caused, whether by Humanscale’s negligence or otherwise.

The remedies provided above are the purchaser’s sole remedies for any failure of Humanscale to comply with its obligations regarding the workmanship of its products. Correction of any nonconformity in the manner and for the period of time provided shall constitute complete fulfillment of all liabilities of Humanscale, with respect to or arising out of the product furnished hereunder.



Ergo Tools

TXMAS Price Guide



U.S. Headquarters

11 East 26th Street
8th Floor
New York, NY 10010
212 725 4749
212 725 7545 fax

Customer Service

10 Inverness Drive East
Suite 100
Englewood, CO 80112
800 400 0625
303 858 9912
303 858 9916 fax
info@humanscale.com

European Headquarters

13 Northburgh Street
London
EC1V 0JP
United Kingdom
+44 207 566 7990
+44 207 566 7991 fax
info@humanscale.co.uk

www.humanscale.com

Our Design Philosophy

At Humanscale, we believe the best designs in the world are based on purpose and function. If a design solves a functional problem as simply and elegantly as possible, the resulting form will be honest and timeless.

Recognized by I.D. Magazine as one of the 10 "Best Companies" worldwide that help push design forward.