

# OmniSeal<sup>®</sup>

Spring Energised Seals



SAINT-GOBAIN

PERFORMANCE PLASTICS



# A Worldwide Leader in High Performance Sealing

OmniSeal®, a recognized name in sealing for over fifty years. First as Fluorocarbon then Furon and now as Saint-Gobain Performance Plastics (SGPPL). OmniSeals, have been used in a multitude of applications where durability, resistance to chemicals and operation at temperature extremes is crucial. Our spring energised seal designs are widely recognized throughout the industry. OmniSeal high-performance spring energised seals reduce friction, operate in harsh environments, reduce downtime and extend equipment service life.

Compagnie de Saint-Gobain has a rich tradition of excellence that dates back over 300 years to its founding. Today it is one of the world's top 100 industrial corporations and a leader in the development and production of engineered materials. Established in France in 1665 as a glass maker, Saint-Gobain continues through arduous research to develop new and innovative materials.

Today, Compagnie de Saint-Gobain is a global leader in each of its businesses, including flat glass, containers, insulation, building materials, abrasives, high performance seals, industrial ceramics and piping.



# OmniSeal® Seals in the Marketplace

SGPPL's proprietary blends of engineered polymers can be coupled with many spring geometries to offer a superior seal that operates in a variety of different applications in a range of industries, including:

- Aircraft, Aerospace
- Transportation (Heavy Truck, Automotive, Marine, Rail)
- Construction Equipment
- High Performance Racing
- Medical Instrumentation
- Liquid Chromatography
- Semiconductor Manufacturing Equipment
- Petroleum and Chemical Process Equipment
- Pumps, Valves, Compressors

The acceptance of OmniSeal seals across this wide range of applications confirms their versatility and outstanding performance. Design engineers throughout the world enjoy the opportunity to specify both superior design and a multiplicity of materials with every OmniSeal product.

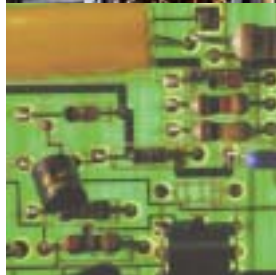
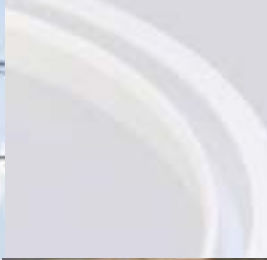

COPYRIGHT AIRBUS S.A.S. Computer Graphics by I3M



# Technology

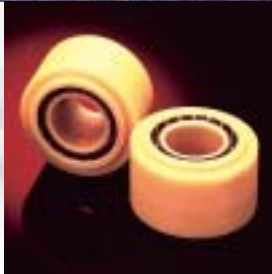

## High Performance Seals

Backed by a proud heritage of product innovation, technological expertise and market leadership, Saint-Gobain Performance Plastics is dedicated to working with our customers to solve today's tough seal application issues and the challenges that lie ahead.

OmniSeal seals are manufactured throughout the world, with sites located in North America and South America, Europe and Asia.

The seals were originally designed and developed in Southern California. The current facilities located in Garden Grove, California, Kontich in Belgium and Suwa Japan design and manufacture High Performance Spring Energised Seals, according to ISO 9100 standards. Experienced design engineers, state of the art production equipment and a comprehensive testing laboratory support the development of special designed OmniSeal seals.

# Table of Contents

## OmniSeals

How OmniSeal seals Work . . . . .	6
Radial Seals - Seal Function & Motion . . . . .	7
Face Seals - Seal Function and Motion . . . . .	8
Installation OmniSeals . . . . .	8
Friction and Rotary Motion . . . . .	9
Temperature, Pressure and Extrusion Gap . . . . .	10
Hardware, Finish & Hardness . . . . .	11
OmniSeal Back-Up Rings . . . . .	12
Seal Design Variations . . . . .	13
Seal Jacket Materials . . . . .	14
Spring Energiser Materials . . . . .	15

## Radial Seal, Radial & Face Seals

Radial Seals - OmniSeal Series 103A . . . . .	16
OmniSeal Series 103A - Hardware . . . . .	17
Radial Seals - OmniSeal Series 400A . . . . .	18
OmniSeal Series 400A - Hardware . . . . .	19
Radial Seals - OmniSeal Series APS . . . . .	20
OmniSeal APS Series - Hardware . . . . .	21
Radial Seals - OmniSeal Series RP II . . . . .	22
OmniSeal Series RPII - Hardware . . . . .	23
Face Seals - OmniSeal 103A, 400A, APS & RACO® Series . . . . .	24
OmniSeal Face Seals Series - Hardware . . . . .	25
Minimal Seal Diameters . . . . .	25
Typical Installations . . . . .	26
Application Data Form . . . . .	27

## Special Seals

Special Seal Designs . . . . .	28
Other Products . . . . .	31

# How OmniSeal seals Work

## OmniSeal Components

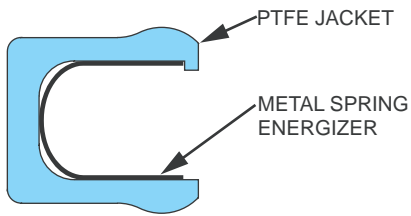

The OmniSeal is a spring actuated, pressure assisted sealing device consisting of a PTFE (or other polymer) jacket, partially encapsulating a corrosion resistant metal spring energiser.

When the OmniSeal is seated in the gland, the spring is under compression, forcing the jacket lips against the gland walls thereby creating a leak-tight seal.

The spring provides permanent resilience to the seal jacket and compensates for material wear and hardware misalignment or eccentricity. System pressure also assists in energizing the seal jacket. Spring loading, assisted by system pressure provides effective sealing at both low and high pressures.

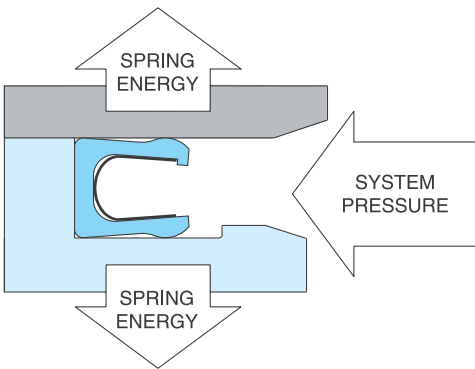

*OmniSeal 400A in working conditions*

OmniSeal jackets are precision machined from PTFE, filled PTFE composites and other high performance polymers. OmniSeal seals with PTFE jackets are serviceable at temperatures ranging from cryogenic to + 300°C and are inert to virtually all chemicals except molten alkali metals, fluorine gas at high temperature and chlorine trifluoride (ClF<sub>3</sub>).

OmniSeal seals are available with a variety of spring energisers, each having characteristics to meet specific requirements. Spring loading can be tailored to meet critical low friction requirements in dynamic applications, or extremely high loading often required for cryogenic

sealing. Springs are fabricated from corrosion-resistant metals such as 300 Series and 17-7 PH stainless steels, Elgiloy®, Hastelloy® and Inconel.

OmniSeal seals with elastomer O-rings used as energisers (nitrile, silicone, Fluoroelastomer, OmniFlex™, etc.) are also available by contacting the factory.

The geometry of the OmniSeal installed in the gland, provides positive resistance to torsional or spiral failures often found in O-rings. OmniSeal seals (with metal springs) have unlimited shelf life and are not subject to age controls normally imposed on elastomeric seals.

## Selecting an OmniSeal Design

Saint-Gobain Performance Plastics manufacturers and markets a variety of basic styles of spring energised PTFE Fluoroloy® seals. Several of these designs can be used interchangeably in the same gland.

The recommendations that follow are intended as a general guide and should be used together with the tables and dimensional charts that appear on the following pages. Should you require additional assistance, please contact the factory. For complete contact information see the inside back cover.

## Static Seals and Dynamic Seals

The two basic types of sealing applications are STATIC SEALS and DYNAMIC SEALS. In static sealing there is essentially no relative motion between the seal and the hardware members. An example would be a seal clamped between bolted flanges.

In dynamic sealing there is relative motion between the two sealing surfaces. A typical example would be the rod and piston seals in a hydraulic cylinder.

There are two directions of motion in dynamic sealing, reciprocating or linear motion, and rotary (including oscillating) motion.

Occasionally there may be a combination of both static and dynamic applications. An additional factor to be considered is the orientation of the seal in the hardware. Seals that are compressed in a radial direction are called radial seals, again using rod and piston seals as examples.

Seals that are compressed in a direction parallel to the axis are called Face Seals, the flange gasket being a typical example.

Typical installations are shown on Page 26.

# Radial Seals - Seal Function & Motion

## Radial Seals in Static Service

While most of the OmniSeal designs can be used as static radial seals, the OmniSeal 103A, Page 16, is generally recommended for this service. Its moderate to high spring load provides positive sealing under most static sealing conditions.

## Radial Seals in Reciprocating Motion

Reciprocating radial seals are the most common OmniSeal applications. For rod and piston sealing and similar applications, the OmniSeal 400A, Page 18, is recommended for general purpose sealing at low to moderate pressures. This series has a low load, high deflection spring which provides low friction sealing, long wear life, and compensates for minor hardware eccentricity or misalignment.

OmniSeal APS (Advanced Pitch Spring), Page 20, uses a unique design of a round wire spring energiser which has the advantage of producing an almost constant spring load over a wide deflection range. This type of seal accommodates variation in hardware dimensions (tolerances) and/or provides effective sealing loads over a large seal wear allowance. Also, it can be wound in very small coil diameters, which makes it particularly suitable for miniature seals and seals requiring low friction values.

For better sealing at low speeds, the OmniSeal 103A, Page 16, is recommended. The higher spring load provides positive sealing with some increase in seal friction. Particularly suitable for medium to high pressure service, the 103A is also an excellent rod seal for positive sealing.

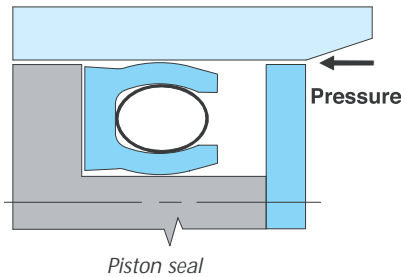

*Piston seal*

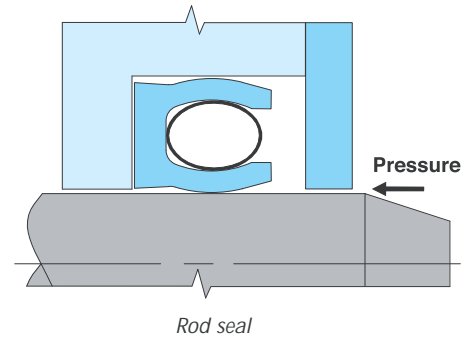

*Rod seal*

The OmniSeal RP II, Page 22, is a very rugged design for severe operating conditions. This seal utilizes a unique wrapped and formed stainless steel ribbon spring which is highly resilient with wide deflection capabilities. Its durable spring and rugged jacket design makes the OmniSeal RP II an excellent choice for heavy-duty sealing applications and long wear life.

The Spring Ring II, is an economical alternative to the OmniSeal 400A for high production applications requiring low cost, small size seals. It is manufactured by automated methods and is offered only in a limited number of sizes 3 to 25 mm I.D. Design and sealing characteristics are similar to the OmniSeal 400A.

## Radial Seals in Rotary Motion

All of the OmniSeal designs can be used in slow to moderate speed rotary or oscillatory applications at low pressure.

In rotary shaft applications the flanged design is preferred. The flange is clamped in the hardware to prevent the seal from turning with the shaft. This can sometimes occur with the standard designs due to thermal and other effects. The flange provides positive hardware retention.

The flanged OmniSeal 400A, page 18, and the flanged OmniSeal APS on page 15 are recommended for most rotary/oscillatory applications. The light spring load minimizes friction, at pressures under 1,5 MPa, with surface speeds in the range of 1-1,5 m/s. At higher pressures, reduced surface speeds are required to prolong seal wear life. The resilient 400A and APS spring allows for minor shaft runout or misalignment.

For very slow speeds, under 0,5 m/s. and intermittent rotary/oscillatory motion at higher pressures, the flanged OmniSeal 103A, Page 16 and OmniSeal RP II, Page 22, are recommended. The OmniSeal RP II has a very resilient spring that can tolerate above normal shaft run-out and misalignment.

For applications requiring ultra-low friction, high pressures or high surface speeds we suggest that you contact our Technical Support. (See inside back cover for complete information.)

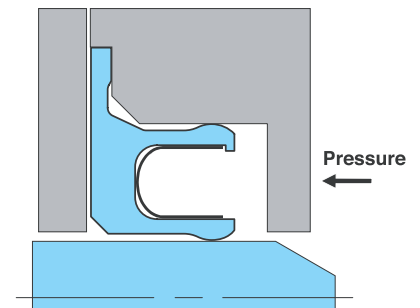

*Flanged 400A,  
typical flanged jacket*



# Face Seals-Seal Function and Motion

## Face Seals in Static Service

The OmniSeal 103A, face seal is generally the first choice for most static face seal applications. This series utilizes a moderate to high load spring, and is capable of sealing effectively over a wide temperature and pressure range.

Because of its very high spring loading, the OmniSeal RACO® 1100A, is particularly recommended for extreme sealing conditions, cryogenic temperatures, ultra-high vacuum and positive sealing of helium and other light gases.

The OmniSeal 400A, may also be used as a static face seal when light spring loading is essential. However, its sealing ability may not be as effective under extreme conditions as possible with the 103A or the RACO 1100A due to the relatively light spring load.

## Face Seals in Dynamic Service

OmniSeal 400A, is recommended for rotary face seal applications at slow to moderate rotary speeds. Low spring loading keeps friction to a minimum. For ultra-low friction or high surface speed contact the factory.

The OmniSeal APS, is an ideal choice for use in dynamic reciprocating and rotary applications. Due to the flat load curve of the Advanced Pitch Spring (APS), it also provides excellent service in friction sensitive applications.

In oscillatory or slow, intermittent rotary applications where high rotational torques are available, the OmniSeal RACO 1100A, is recommended. Such applications include swivels and loading arm pivot joints. Because of its exceptionally high spring load, the OmniSeal

RACO 1100A is also an excellent choice when maximum sealability is mandatory in liquids and gases with a low specific gravity and sealing at cryogenic temperatures.

### Inside Face Seal

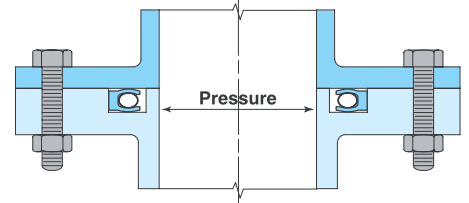

### Outside Face Seal

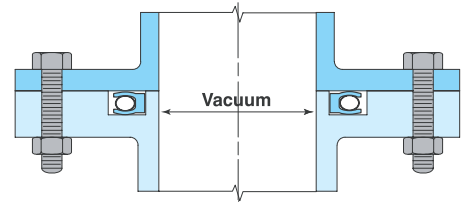

### Groove Sizes Part Number Designation See page 24-25

## Installation

Unlike Rubber O Rings, OmniSeal Seals do not stretch without damage. Therefore it is desirable to install OmniSeal spring energised seals in open groove designs. If closed (non-split) or half open grooves are inevitable then make sure that, even more than with open grooves, all parts in touch with the seal when assembled are free from scratches and sharp edges. Otherwise the seal may be damaged.

Assembling seals in closed grooves, located piston-wise will be easier than bore-wise assembling. Piston-wise assembling means the seal has to be

stretched. Depending on the diameter this stretching can be done by heating up the seal, so that natural expansion will reduce the elongation needed to bring the seal in the groove. When cooling down again the seal will shrink back to the nominal size.

Bore-wise assembling means the seal has to be deformed, and special care should be taken when pushing the seal in the groove.

OmniSeal 103A, 400A and APS type seals can be installed in closed grooves. It is not recommended to install small diameter type 400A (U-spring) seals in closed grooves.

Bigger diameter seals are typically easier to install in closed grooves than smaller sized seals. Consult factory for seals diameters smaller than 20 times the seal cross-section. Saint-Gobain Performance Plastics can assist you with special assembly tools.



# Friction and Rotary Motion

## Friction

Friction, a measurement of the resistance to sliding between a seal and hardware surfaces, is directly related to seal material coefficient of friction and the normal load. Some other factors affecting friction are lubrication, temperature and hardware surface finishes. An approximate friction value for non-lubricated conditions can be

calculated using the charts and formulas on this page. Lubrication provided by the media may produce lower friction results.

It is difficult to predict how the running and break-out friction values will differ without testing under actual existing conditions. SGPPL manufactures a variety of springs

with lower or higher loads than shown on this page. Also, special springs can be developed when required.

For assistance with applications where friction is critical. Contact our Technical Support. (see inside back cover for complete information.)

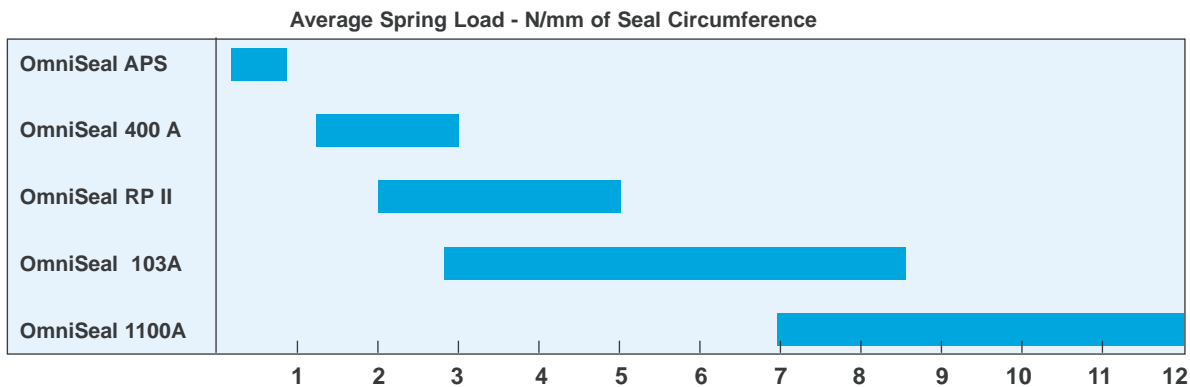

Note: The values above are for standard spring materials and thicknesses. Other materials and spring thicknesses may be substituted; consult factory for availability.

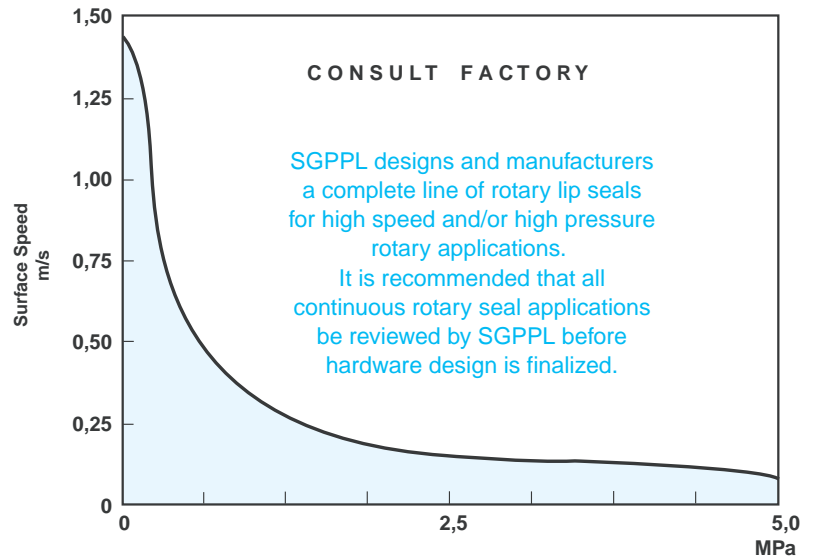
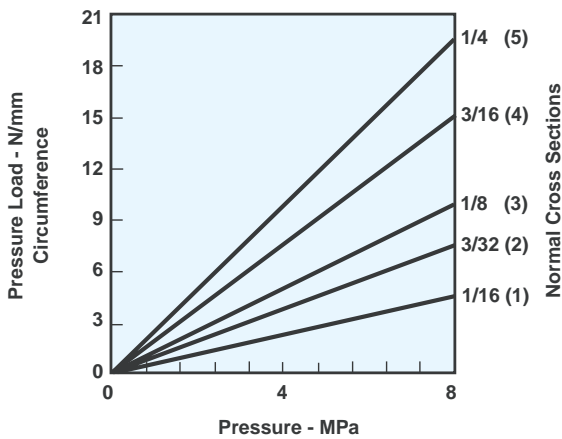

**F** = Total load—N/mm circumference (pressure load + spring load)  
**D** = Diameter of dynamic surface  
**R** = D/2 (Radius)  
**μ** = Material coefficient of friction (See Page 14)  
**Linear Friction (N)** =  $F \times D \times \pi \times \mu$   
**Frictional Torque (Nm)** =  $F \times D \times \pi \times \mu \times R$

The approximate total load of an OmniSeal can be calculated by adding the pressure load found in the chart above to the average spring load shown in the top chart.

## Rotary Motion

Use the chart above to qualify OmniSeal seals for continuous rotary applications.

# Temperature, Pressure and Extrusion Gap

## HT/HP Sealing

When sealing high pressures and/or high temperatures, the size of the extrusion gap behind the seal becomes critical.

*This extrusion gap is the clearance between the hardware members. Hardware designs without bearing or centering devices must consider the diametral clearance as the maximum extrusion gap.* The combination of high pressures and/or high temperatures, excessive clearance can allow the seal jacket to extrude into the gap causing premature failure.

The extrusion gap should be held to the minimum, and should not exceed the values shown in the table (right). Increasing the heel thickness of the seal improves resistance to extrusion. Also, the extrusion gap can be bridged by the use of a separate back-up ring arrangement.

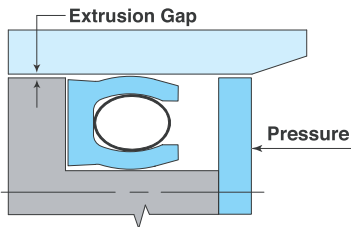

Generally, the back-up ring should be of a harder material than the seal material. A high filled PTFE compound, or a high modulus plastic such as A22, is recommended. See materials shown on page 14. Additional back-up ring details are shown on Page 12.

## Cryogenic Sealing



Cold temperatures below -40°C will cause PTFE and other polymer sealing materials to shrink and harden. These additional forces may compromise the spring load and frictional characteristics of the OmniSeal.

Although face seals are less affected than radial seals, we recommend consulting our Seal Technical Support team before selecting an OmniSeal for any cryogenic application.

## Seal Design Vs. Temperature

In general, seal jacket materials become somewhat harder at cold temperatures and tend to soften to some extent at high temperatures (see material list on Page 14 for temperature ranges). The spring energiser compensates for these conditions. If your seal design selection does not agree with the graph (right), contact our Technical Support. (see inside back cover for complete information.)

Maximum Recommended Extrusion Gap

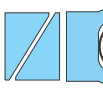
(OmniSeal 103A Shown for Illustration Only)			A	B	C	D
	Unfilled		0,10	0,07	0,05	—
	Filled		0,15	0,10	0,07	—
	Unfilled		0,15	0,10	0,07	—
	Filled		0,20	0,15	0,10	0,07
	Filled—Back-Up		0,20	0,15	0,10	0,07
	A22—Back-Up		0,25	0,20	0,15	0,10
	Filled—Back-Up		0,25	0,20	0,15	0,10
	A22—Back-Up		0,35	0,25	0,20	0,15

Note: Consult Technical Support for extrusion gap information regarding specific applications.

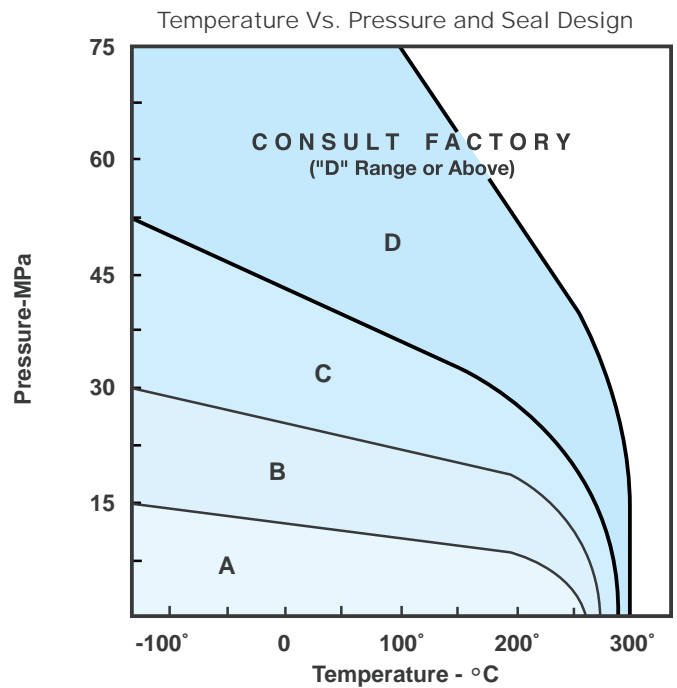

Seal Design Vs. Temp. Chart.

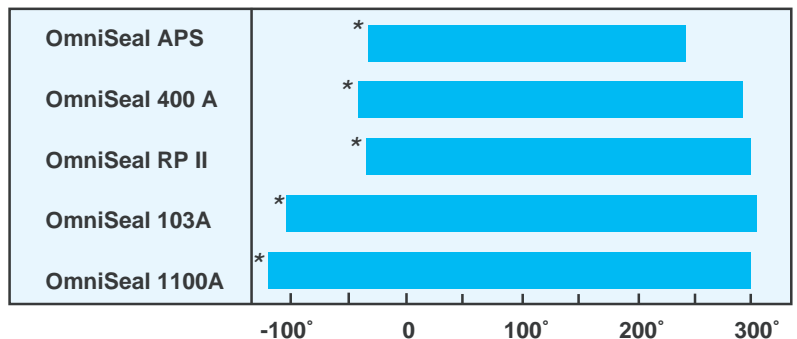

\* For temp. below -20°C consult factory

## Dynamic Hardware Surfaces

The finish of the surface over which the OmniSeal must slide greatly influences the relative wear of the cover material. Mating surfaces that are too rough can create leak paths and be abrasive to the seal.

The transfer of a thin film of PTFE from the OmniSeal cover to the mating dynamic surface will improve

seal life. Dynamic surfaces with relatively rough finishes wear the jacket material too rapidly. Extremely smooth dynamic surfaces result in insufficient material transfer to form a thin film. The graph below illustrates the effect of surface finish on seal wear.

## Static Hardware Surfaces

In most static sealing applications, better overall sealing performance can be achieved with a smoother sealing surface finish. With OmniSeal the recommended optimum surface finish for most static sealing applications is 0,8 Ra or better. The "lay" on surfaces for static face seals must be concentric.

**Hardware Surface Finish Recommendations**

Fluid Belting Sealed	Surface Finish	
	Dynamic Surface	Static Surface
Cryogenics Helium Gas Hydrogen Gas Freon	0,1 to 0,2 Ra	0,1 to 0,2 Ra
		0,15 to 0,3 Ra
Air Nitrogen Gas Argon Gas Natural Gas Fuel (Aircraft, Automotive)	0,15 to 0,3 Ra	0,3 to 0,8 Ra
Water Hydraulic Oil Crude Oil Sealants	0,2 to 0,4 Ra	0,4 to 0,8 Ra

*Consult Technical Support for proper surface finish of gland and shaft, and media recommendations.*

**Dynamic Surface Finish Chart**

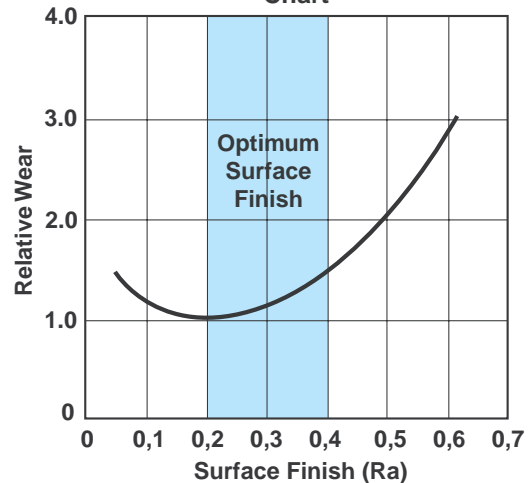

## Dynamic Hardware Sealing Surface Hardness

As a general rule, the higher the sealing surface smoothness the better the overall seal performance can be expected. Better smoothness reduces wear and increases seal life. A 40 Rockwell C or greater is recommended for slow to moderate reciprocating motion.

The ideal hardness is 60 to 70 Rockwell C. Hardness in this range is recommended for moderate to high speed linear or rotary motion. Hard anodized surface must be polished after anodizing.

## Gland Design

Consideration of proper gland geometry in the early stages of design can eliminate unnecessary installation problems.

The use of split or separable glands in piston and rod seal applications is always desirable to eliminate stretching or compressing the OmniSeal during installation into the gland. Split glands also eliminate the need for special installation tools.

To minimize stretching or distortion during assembly in non-split glands, the gland side wall on the pressure

side can be reduced to provide a partial shoulder to retain the seal.

If stretching into a full groove is unavoidable, consult our technical department. (see inside back cover) Assembly of the seal over sharp corners, threads, keyways, etc., should be avoided, or protective tooling should be used when these conditions exist.



# OmniSeal Back-Up Rings

**Back-Up Rings** are used when sealing fluids or gases at high temperature and high pressure combinations. Careful attention is also required at high pressure and high speed reciprocation conditions. If the application parameters fall outside the limits set in the tables on page 10, we strongly advice to contact our technical support for further assistance.

Extrusion is a function off

- a) the size of the extrusion gap
- b) the temperature
- c) the system pressure
- d) surface speed (reciprocating movements)

Under pressure the PTFE tends to flow into the extrusion gap. Dynamic reciprocating movements increases extrusion. Under static conditions however and when pressure, temperature and extrusion are below certain limits, extrusion will stop as soon as the friction in the extrusion gap equals the pressure. Cycling conditions however can cause the extrusion to continue, resulting in premature failure of the seal.

## Rectangular Back-Up (fig. 1)

In most applications with lower pressure and temperatures below 250° C, a rectangular backup will secure the seal for extrusion. Such backup rings are machined to fit exactly in the radial groove width. The material should be a compound with a higher extrusion resistance then the seal's material.



fig. 1

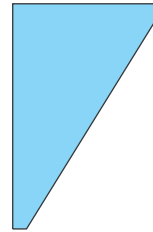

fig. 2

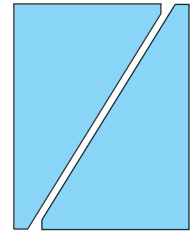

fig. 3

## Triangular Back-Up (fig. 2)

In some cases where a high temperature precedes a high pressure it is recommended to use a triangular backup.

## Double Triangular Back-Up closing the extrusion gap and preventing extrusion of the seal. (fig. 3)

For extreme high pressure and temperature combinations it is recommended to use a set of two triangular back up rings. It is very important to assemble the 90° corner of the backup ring towards the extrusion gap. This type of backup ring is often used when the radial groove dimension changes as a result of the system pressure.

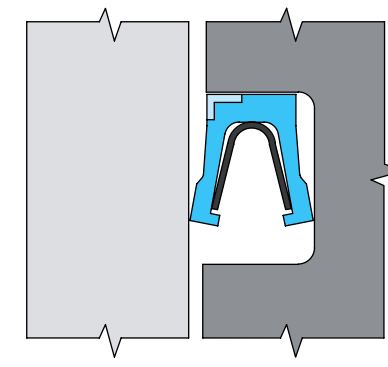
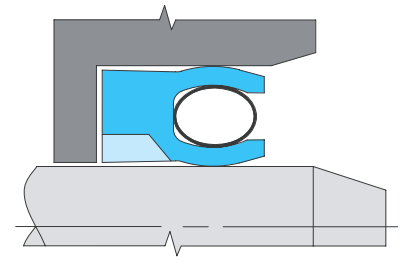

fig. 4



High modulus anti-extrusion/wear ring

## L-shaped Back-Up (fig. 4)

The L-shaped backup ring is used for preventing extrusion at extreme high pressure and high temperature combinations. It is capable of securing PTFE seals up to + 300°C and extreme pressures, such as 20 MPa, with very large extrusions gaps.

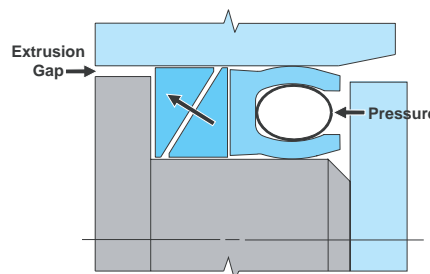

Piston seal installation with split back-up rings

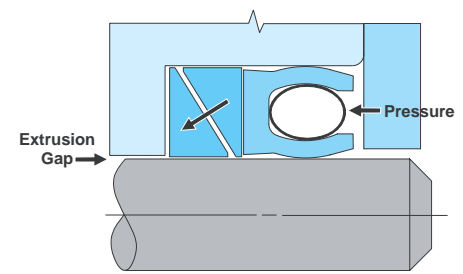

Rod seal installation with split back-up rings

# Seal Design Variations



Saint-Gobain Performance Plastics offers the industry's most complete line of spring energiser configurations.

**OmniSeal 103A Spring Design**

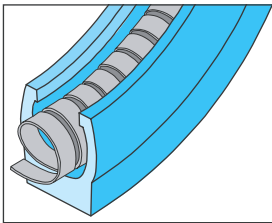

**OmniSeal 400A Spring Design**

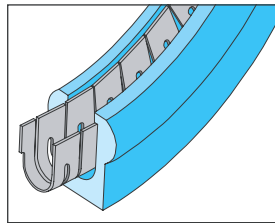

**OmniSeal APS Spring Design**

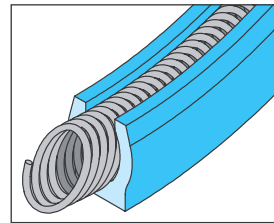

**OmniSeal RPII Spring Design**

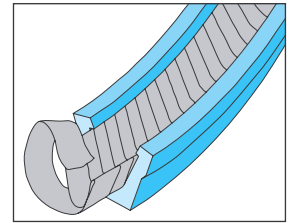

**OmniSeal RACO 1100A Spring Design**

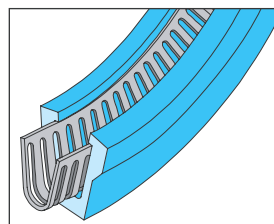

## Skived Lip

All OmniSeal designs except OmniSeal RP II can be supplied with a sharp edge on either the I.D. or O.D. sealing lip. This edge provides a scraper/wiper action for sealing abrasive or viscous media. May also be used as an environmental excluder.



## Extended Heel

OmniSeal seals can be supplied with an extended heel section for improved resistance to extrusion at high temperatures and/or high pressures. See page 14 for material selection guidance.



## Flanged Heel

The flanged heel design is recommended for rotary/oscillatory shaft applications. The flange is clamped in the seal housing to prevent the seal from turning with the shaft.

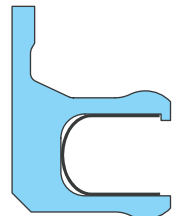

# Seal Jacket Materials

## SGPPL Seal Jacket Materials

SGPPL seal jacket materials are compounded and processed for optimum performance in a wide variety of sealing environments. The materials listed below are our most commonly recommended compounds, and

are suitable for most applications. Over the years SGPPL has developed over 500 materials for seal use. These additional compounds are available should they be required in special applications. SGPPL is continually

formulating and developing new materials. For more information, contact our Technical Support (see inside back cover).

Fluoroloy Code No.	Color	Application All Formulated Materials are Proprietary to Saint-Gobain Performance Plastics	Temp. Range Degrees °C.	Coefficient of Friction	Wear K Factor 15000 = Poor 1 = Excellent
A01	White	<b>Virgin PTFE</b> Excellent for light to moderate dynamic and static service. Limited wear and heat resistance. Low gas permeability. Good cryogenic properties. Moderate to hard vacuum service. FDA approved.	+260° To -260°	.09	7500
A02	White	<b>Modified PTFE</b> Excellent for light to moderate dynamic and static service. Limited wear and heat resistance. Low gas permeability. Good cryogenic properties. Moderate to hard vacuum service. FDA approved. Improved creep and extrusion resistance.	+280° To -260°	.09	6000
A08	Tan	<b>Polymer Filled PTFE</b> Superior heat and wear resistance. Non-abrasive. Recommended for moderate to high speed dynamic service running against soft metals.	+315° To -260°	.15	2
A09	Yellow	<b>Formulated UHMW - PE</b> Extremely tough, long wearing but limited heat and chemical resistance. Particularly suitable for abrasive media. Recommended for long wear life under severe conditions.	+90° To -260°	.11	9
A12	Gold	<b>Polymer Filled PTFE</b> Tough, long wearing, heat resistant. Very low friction. Excellent for dry running applications against soft surfaces. Excellent material for reciprocating applications.	+315° To -240°	.09	9
A15	Gray	<b>Lubricated Glass Filled PTFE</b> Similar to A30 material but some what softer for improved sealing at low pressure. Can be abrasive running against soft metals.	+315° To -240°	.09	5
A16	Black	<b>Lubricated Organic Filled PTFE</b> Excellent general purpose material for heat and wear resistance. Recommended for dry and poorly lubricated applications. Particularly suitable for water and steam service.	+315° To -260°	.09	12
A22	Tan	<b>Virgin PEEK</b> A high modulus material with excellent high temperature resistance. Recommended for back-up rings and for specials applications.	+315° To -200°	.40	20
A30	Gold	<b>Glass Formulated PTFE</b> Excellent heat, wear and chemical resistance. Good cryogenic properties. Caution: Can be abrasive running against soft metals at high surface speeds. Excellent material for back-up rings.	+315° To -260°	.09	6
A40	Tan	<b>Polymer Filled PTFE</b> Good wear resistant material for medium hard counterfaces. Caution when used in wet applications. FDA compliant.	+315° To -260°	.10	6
A41	Black	<b>Modified Filled PTFE</b> Excellent all purpose high wear material. Best for dynamic applications running on moderate to hard surfaces.	+315° To -260°	.09	30
A42	Black	<b>Lubricated Formulated PTFE</b> Excellent general purpose material with good heat and wear resistance. Non-abrasive. Compatible with all hydraulic fluids and most chemicals. Good in water and non-lubricating fluids.	+315° To -260°	.09	30
A45	Brown	<b>Polymer Filled PTFE, FDA compliant.</b> Excellent wear material for higher temperatures, pressures and speeds. Superior in dry or poor lubricated applications.	+315° To -260°	.09	1
A46	White	<b>FDA Compliant Filled PTFE</b> Good wear resistant material against all stainless steel counterfaces. This material may be used in contact with food.	+315° To -260°	.20	150
A47	White	<b>FDA Compliant Filled PTFE</b> Very good wear resistant material under wet or lubricated conditions. May be used in contact with foods.	+315° To -260°	.11	9







# Spring Energiser Materials

The metallic spring and elastomeric energisers available with OmniSeal seals are listed in the chart below. Because of the almost infinite variety

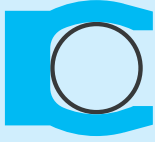
of fluidmedia that may be encountered by the seals, no attempt is made to make specific recommendations. The various stainless steels listed are

compatible with most fluids. If you are in doubt about media compatibility, contact our Technical Support. (See inside back cover).

* Optional all sizes. Please contact Seals Technical Support		OmniSeal 103A	OmniSeal 400A	OmniSeal APS	OmniSeal RP II	OmniSeal RACO 1100A
						
Code No.	Description	Page 16	Page 18	Page 20	Page 22	Page 24
01	301 Stainless Steel		Standard		Standard	Standard
02	Inconel® 718					*
04	304 Stainless Steel		*			
05	Elgiloy®	*	*			
06	316 Stainless Steel	*	*	*		
07	17/7 PH Stainless Steel	Standard				
08	Hastelloy® C276		*			
09	302 Stainless Steel			Standard		

Note: Other metallic spring energisers are available. For information regarding design requirements, specific seal designs, unique applications, additional data specifications contact: Technical Support, see inside back cover for complete information.  
Elgiloy® is a registered trademark of the Elgiloy Comp.  
Hastelloy® is a registered trademark of the Haynes Int. Comp.

## Optional Energisers

### Elastomer Energisers

OmniSeal 103A seals may be ordered with optional elastomeric O-Ring energisers in place of the metallic spring. A wide variety of elastomers such as OmniFlex, nitrile, FKM and silicone are available. Contact our Technical Support for more information.

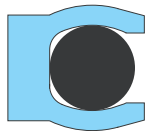

### RTV Silicone Filled

The OmniSeal 400A can be supplied with an FDA-approved grade of RTV silicone filled into the spring cavity. The elastomer ensures that no contaminants can become trapped in the spring cavity, allowing the seal to be used in food processing and clean-in place applications. Other materials are available; contact our Technical Support for individual applications.

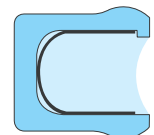

# Radial Seals - OmniSeal Series 103A



## Radial Seal

The OmniSeal 103A is a refinement of the original spring energised seal design. The helical wound flat spring offers a moderate to high spring load for static and slow to moderate speed dynamic sealing. It has higher friction than the 400A Series, but better sealing of light liquids and gases. Available in all aero-space, military and industrial gland sizes.



OmniSeal type 103A is generally used for static applications and when positive sealing is most critical. Its relatively high spring load allows excellent sealing on smooth surfaces and satisfactory sealing on rougher surfaces. The standard spring load averages 5 N/mm circumference, but may be tailored from less than 5N up to 20N/mm circumference, to suit specific sealing specifications. Typically, high loads are required where extremely low leak rates are necessary, as in the sealing of cryogenic gases.

The 103A seal can also be successfully used in slow dynamic applications, both for radial or face seal type applications. (see page 24-25 for face seal info). The largest possible cross section should be selected, especially where application temperatures are in the extremes.

For more information, please contact our technical service and/or fill out the application data sheet on page 27.

Radial	Standard Lip	Skived I.D. Lip	Skived O.D. Lip
Standard Heel G Width			
Part No.	230	231	232
Extended Heel G <sub>1</sub> Width			
Part No.	233	234	235
Flanged Heel G <sub>1</sub> Width			Other shapes available on simple request
Part No.	236	237	

## Part Number System

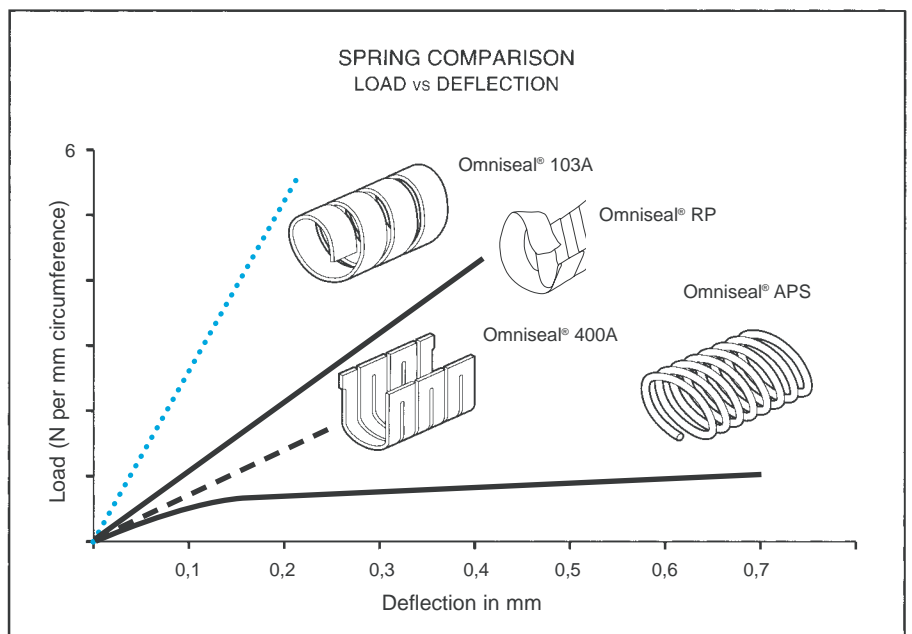
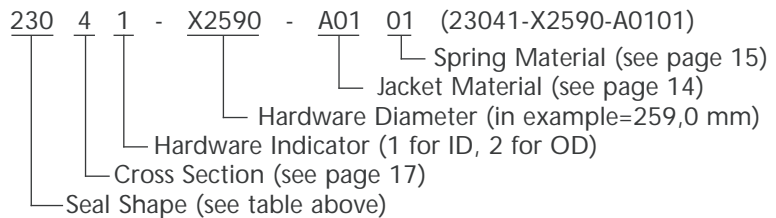

# OmniSeal Series 103A - Hardware

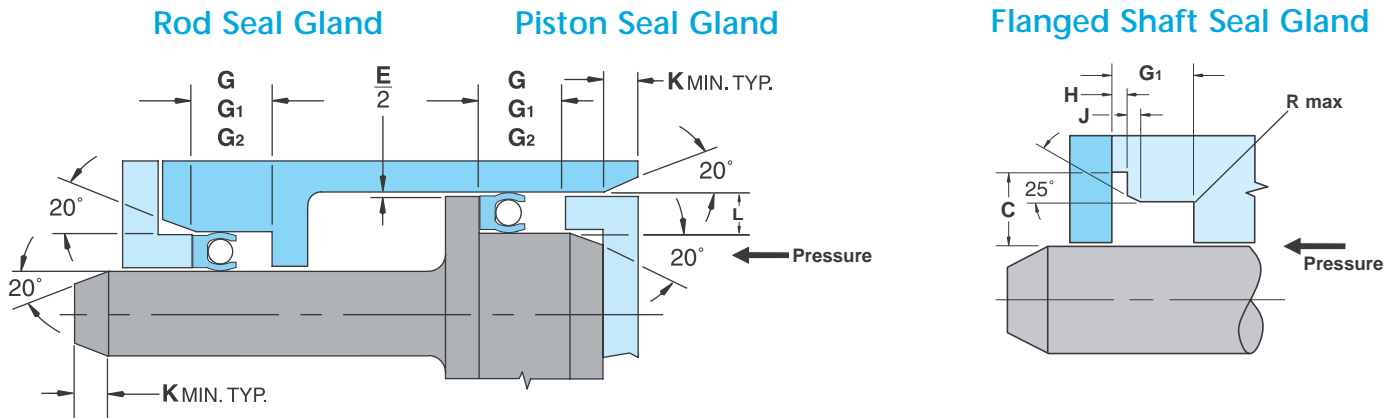

See page 11 for surface finish recommendations

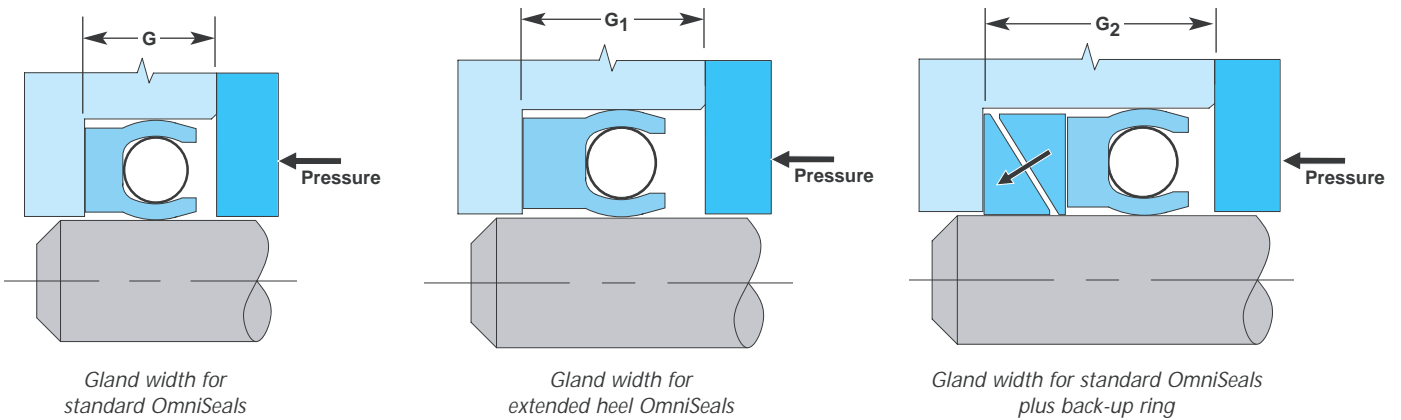

## Radial Seal Gland Designs

X-Section No.	Nominal X-Section	L c/s in mm	G +0,3 -0,0	G <sub>1</sub> +0,3 -0,0	G <sub>2</sub> +0,3 -0,0	K Min.	C ± 0,13	H ± 0,05	J ± 0,13	E NOM (1)	R MAX	Shaft Tol.
1	1/16	1,42/1,47	2,4	3,8	5,3	1,0	3,4	0,40	0,80	0,10	0,10	-0,05
2	3/32	2,26/2,31	3,6	4,6	6,2	1,5	4,3	0,60	0,90	0,13	0,10	-0,05
3	1/8	3,07/3,12	4,8	6,0	7,7	2,4	5,5	0,70	1,30	0,15	0,20	-0,05
4	3/16	4,72/4,78	7,1	8,5	10,8	3,0	8,4	0,80	1,80	0,18	0,25	-0,06
5	1/4	6,05/6,12	9,5	12,1	14,7	4,0	11,6	1,20	2,30	0,20	0,50	-0,07

NOTE: Complete Rod and piston radial seal gland dimensional data for Mil./ind. and AS4716, 1/16"-1/4" X-sections available on request.

(1) See extrusion gap recommendations Page 10

## Alternate Gland Designs

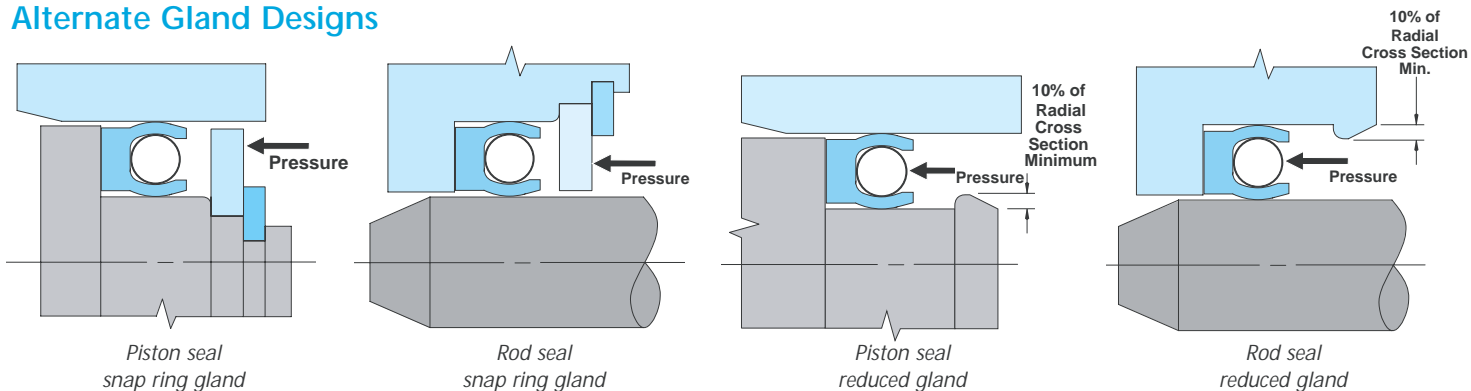



# Radial Seals - OmniSeal Series 400A

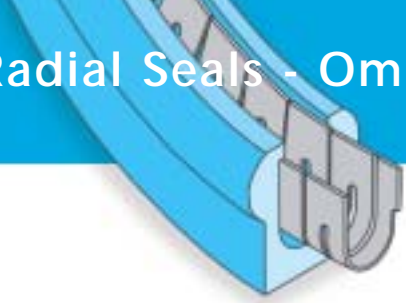

## Radial Seal

The OmniSeal 400A utilizes a cantilevered finger spring design. This unique spring design provides more dynamic runout and wider gland tolerances. Seal friction is reduced substantially, yet remains consistent with positive sealing in both low and high pressures. Available to fit all aerospace, military and industrial gland sizes. Larger cross sections up to 3/4" are also available.



Radial	Standard Lip	Skived I.D. Lip	Skived O.D. Lip
Standard Heel G Width			
Part No.	220	221	222
Extended Heel G <sub>1</sub> Width			
Part No.	223	224	225
Flanged Heel G <sub>1</sub> Width			Other shapes available on simple request
Part No.	226	227	

## Part Number System

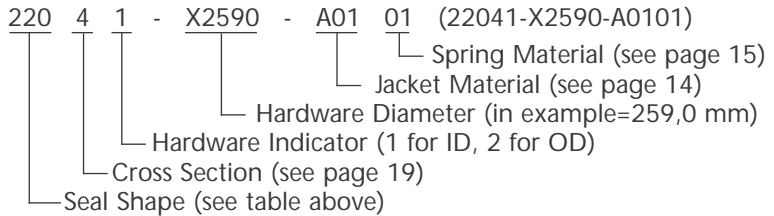

OmniSeal type 400A has been designed for dynamic applications and therefore typically features a lower load spring. In order to obtain the best possible sealing performance, mating surfaces must have a smoother finish than required for type 103A seals. Static surfaces should also have a smooth finish to accommodate the lower load spring performance.

The standard spring load averages 1,5 N/mm circumference, but can be tailored to higher and lower loads. Such loads may be required for extremely low friction values or for enhanced sealing integrity at slower dynamic speeds.

The 400A seal is also the preferred seal for High Temperature/High Pressure applications. The largest possible cross section should be selected, particularly where application temperatures are in the extremes.

Also available in face seal design.

For more information, please contact our technical service and/or fill out the application data sheet on page 27.

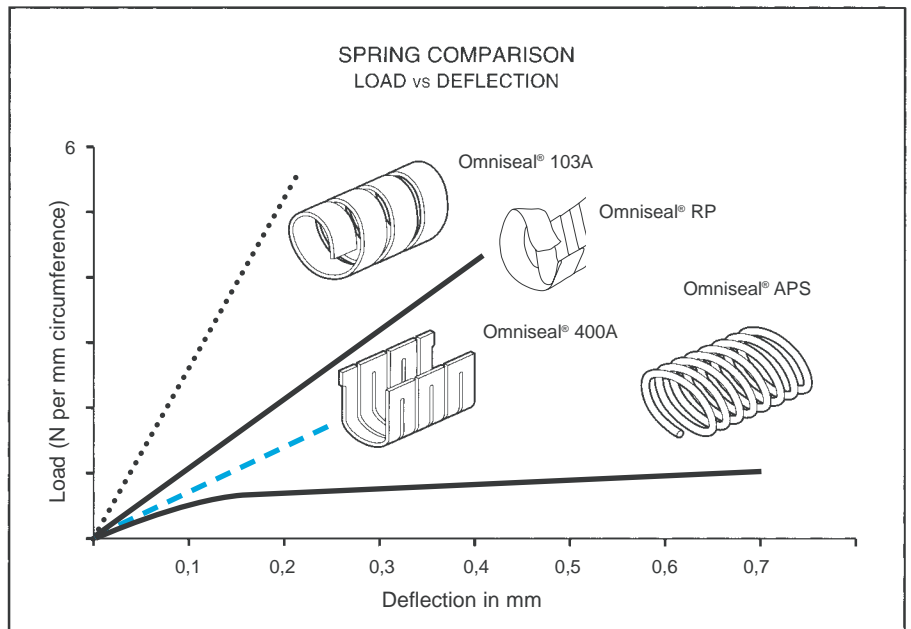

# OmniSeal Series 400A - Hardware

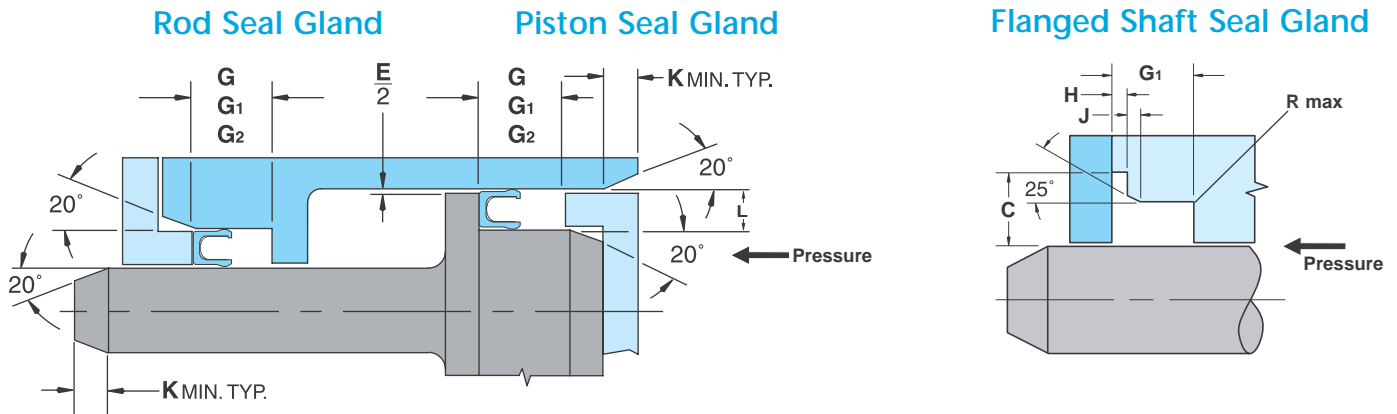

See page 11 for surface finish recommendations

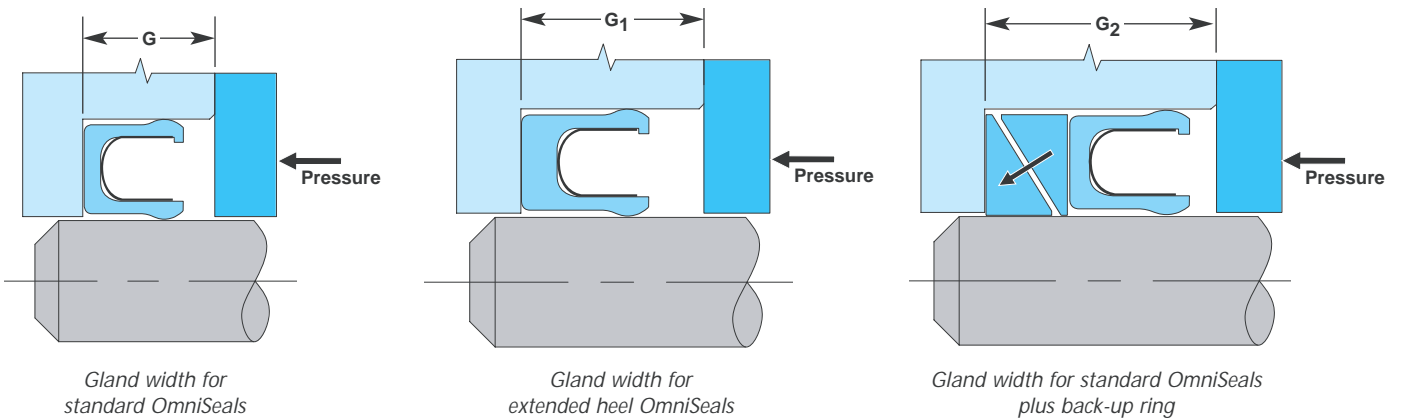

## Radial Seal Gland Designs

X-Section No.	Nominal X-Section	L c/s in mm	G +0,3 -0,0	G <sub>1</sub> +0,3 -0,0	G <sub>2</sub> +0,3 -0,0	K Min.	C ± 0,13	H ± 0,05	J ± 0,13	E NOM (1)	R MAX	Shaft Tol.
1	1/16	1,42/1,47	2,4	3,8	5,3	1,0	3,4	0,40	0,80	0,10	0,10	-0,05
2	3/32	2,26/2,31	3,6	4,6	6,2	1,5	4,3	0,60	0,90	0,13	0,10	-0,05
3	1/8	3,07/3,12	4,8	6,0	7,7	2,4	5,5	0,70	1,30	0,15	0,20	-0,05
4	3/16	4,72/4,78	7,1	8,5	10,8	3,0	8,4	0,80	1,80	0,18	0,25	-0,06
5	1/4	6,05/6,12	9,5	12,1	14,7	4,0	11,6	1,20	2,30	0,20	0,50	-0,07

NOTE: Complete Rod and piston radial seal gland dimensional data for Mil./ind. and AS4716, 1/16"-1/4" X-sections available on request.

(1) See extrusion gap recommendations Page 10

## Alternate Gland Designs

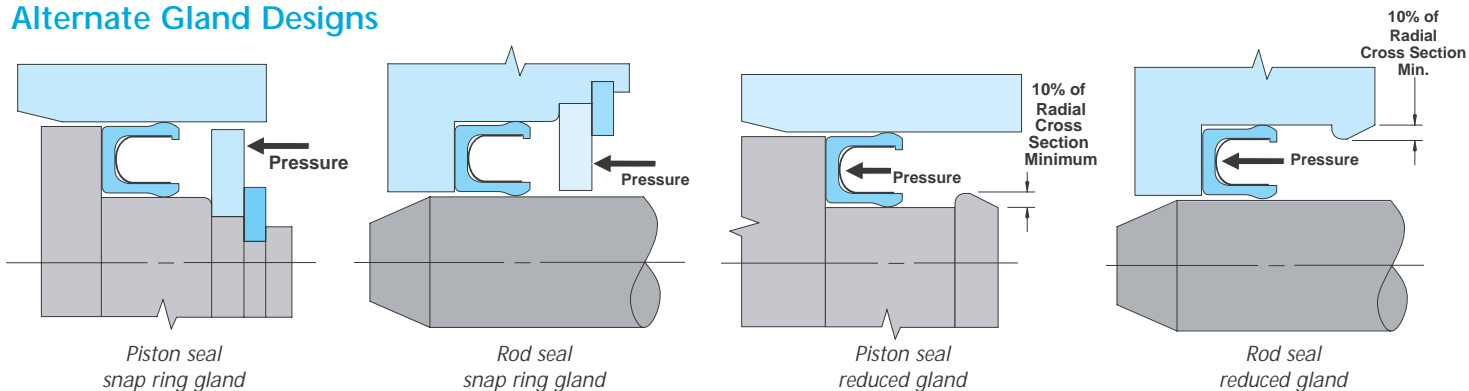

# Radial Seals - OmniSeal Series APS

## Radial Seal

OmniSeal APS (Advanced Pitch Spring) utilizes a unique coiled wire spring design that has a light load and characteristics of a wide range of deflection while producing an almost constant spring load. This feature permits a large wear allowance in the seal jacket while maintaining an effective sealing load. Also, the spring can be wound in extremely small coil diameters, which makes this type of seal ideal for small cross section and small diameter seal applications. The low stressed spring makes it possible to deform the seal, allowing for assembly of rod seals into most closed glands without damaging the spring.



Radial	Standard Lip	Skived I.D. Lip	Skived O.D. Lip
Standard Heel G Width			
Part No.	730	731	732
Extended Heel G <sub>1</sub> Width			
Part No.	733	734	735
Flanged Heel G <sub>1</sub> Width			Other shapes available on simple request
Part No.	736	737	

## Part Number System

730 4 1 - X2590 - A01 01 (73041-X2590-A0101)

- 730 Seal Shape (see table above)
- 4 Cross Section (see page 21)
- 1 Hardware Indicator (1 for ID, 2 for OD)
- X2590 Hardware Diameter (in example=259,0 mm)
- A01 Jacket Material (see page 14)
- 01 Spring Material (see page 15)

OmniSeal type APS (Advanced Pitch Spring) has been designed for applications where a low and constant load (friction) is required over a wide range of deflections. Typically this seal is used in dynamic applications.

The standard spring load averages at 0,3 N/mm circumference, but may be increased or decreased for specific seal performance.

The APS seal is designed for dynamic applications & is available for radial or face seal designs.

For more information, please contact our technical service and/or fill out the application data sheet on page 27.

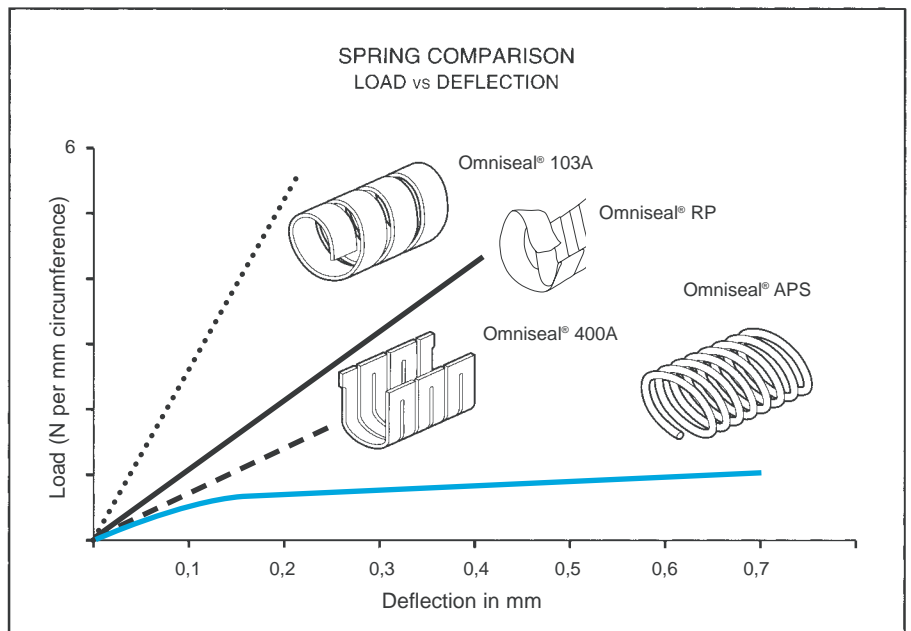

# OmniSeal APS Series - Hardware

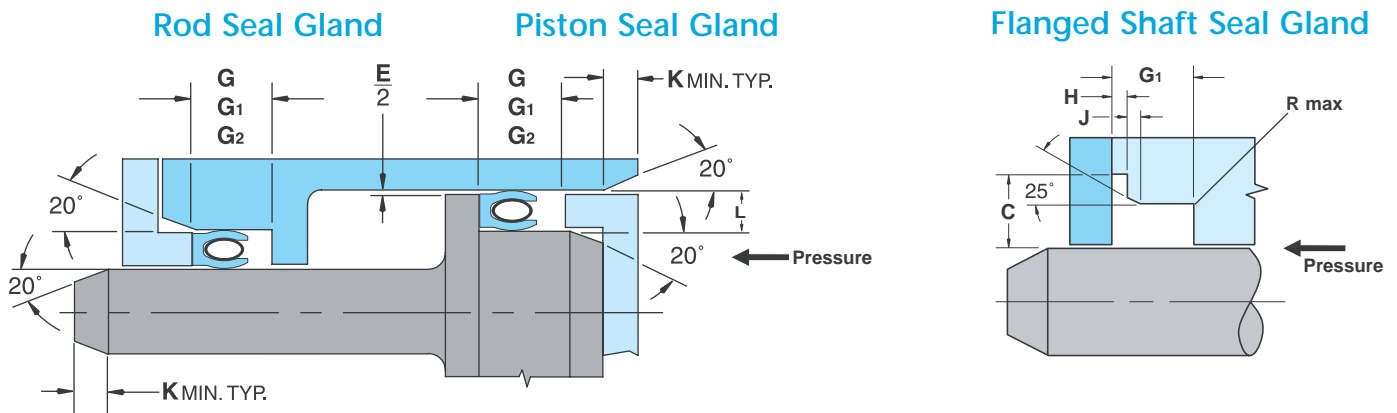

See page 11 for surface finish recommendations

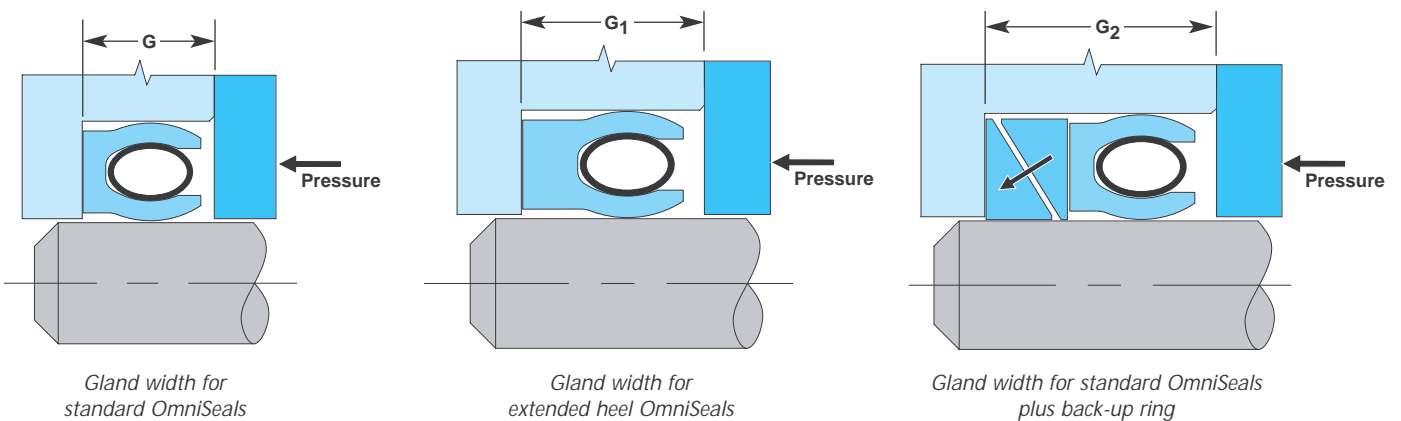

## Radial Seal Gland Designs

X-Section No.	Nominal X-Section	L c/s in mm	G +0,3 -0,0	G <sub>1</sub> +0,3 -0,0	G <sub>2</sub> +0,3 -0,0	K Min.	C ± 0,13	H ± 0,05	J ± 0,13	E NOM (1)	R MAX	Shaft Tol.
1	1/16	1,42/1,47	2,4	3,8	5,3	1,0	3,4	0,40	0,80	0,10	0,10	-0,05
2	3/32	2,26/2,31	3,6	4,6	6,2	1,5	4,3	0,60	0,90	0,13	0,10	-0,05
3	1/8	3,07/3,12	4,8	6,0	7,7	2,4	5,5	0,70	1,30	0,15	0,20	-0,05
4	3/16	4,72/4,78	7,1	8,5	10,8	3,0	8,4	0,80	1,80	0,18	0,25	-0,06
5	1/4	6,05/6,12	9,5	12,1	14,7	4,0	11,6	1,20	2,30	0,20	0,50	-0,07

NOTE: Complete Rod and piston radial seal gland dimensional data for Mil./ind. and AS4716, 1/16"-1/4" X-sections available on request.

(1) See extrusion gap recommendations Page 10

## Alternate Gland Designs

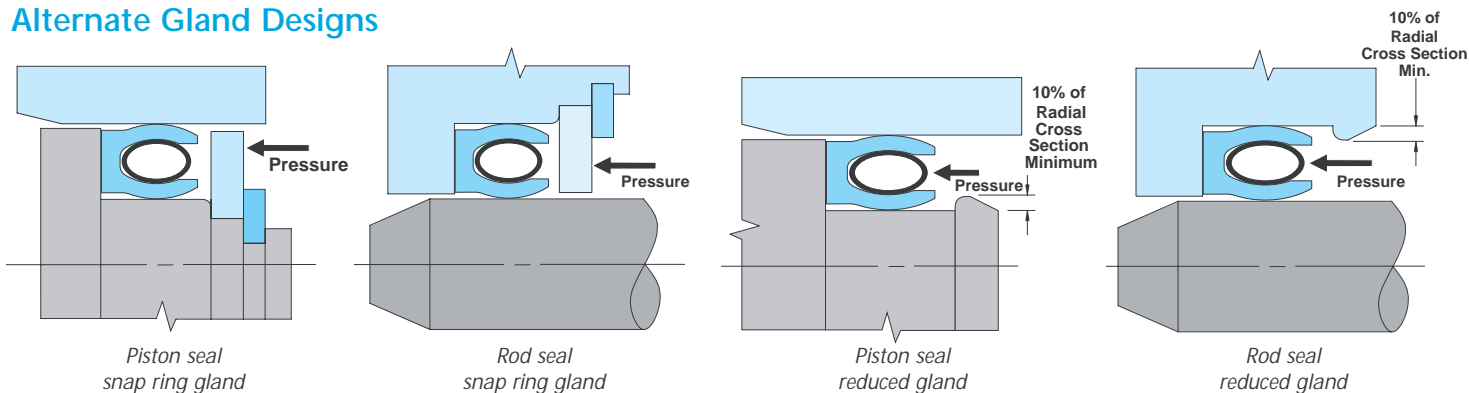



# Radial Seals - OmniSeal Series RP II

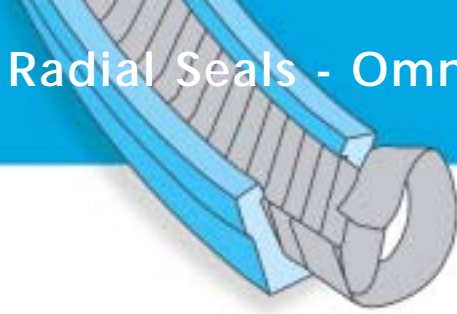

## Radial Seal

The OmniSeal RP II utilizes a wrapped and formed ribbon spring. The design offers the utmost in spring deflection for otherwise difficult sealing applications, and may be used for reciprocating and slow rotary motion in dynamic as well as static sealing.

The Omniseal RP II seal is one of the most rugged of all Saint-Gobain Performance Plastics seals, and will often work under the most severe mechanical conditions when other designs fail. Available in most aerospace, military and industrial gland sizes, as well as larger cross sections.

Radial	Standard Lip
Standard Heel G Width	
Part No.	320
Extended Heel G <sub>1</sub> Width	
Part No.	323
Flanged Heel G <sub>1</sub> Width	
Part No.	326



## Part Number System

320 4 1 - X2590 - A01 01 (32041-X2590-A0101)

- 320 Seal Shape (see table above)
- 4 Cross Section (see page 23)
- 1 Hardware Indicator (1 for ID, 2 for OD)
- X2590 Hardware Diameter (in example=259,0 mm)
- A01 Jacket Material (see page 14)
- 01 Spring Material (see page 15)

OmniSeal type RP has the most resilient spring available in spring energised seals. It has been developed for high deflection and average load conditions, both for static or dynamic applications. The typical spring load is marginally higher than with 400A type seals with 2 to 2,5 N/mm circumference.

The OmniSeal RP seal is only available for *radial seal* type designs.

For more information, please contact our technical service and/or fill out the application data sheet on page 27.

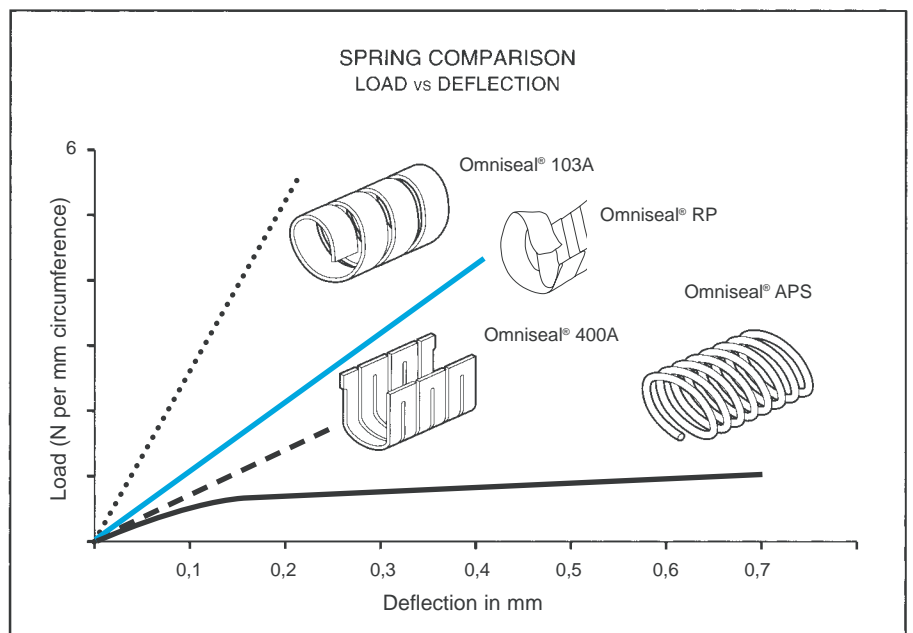

# OmniSeal Series RPII - Hardware

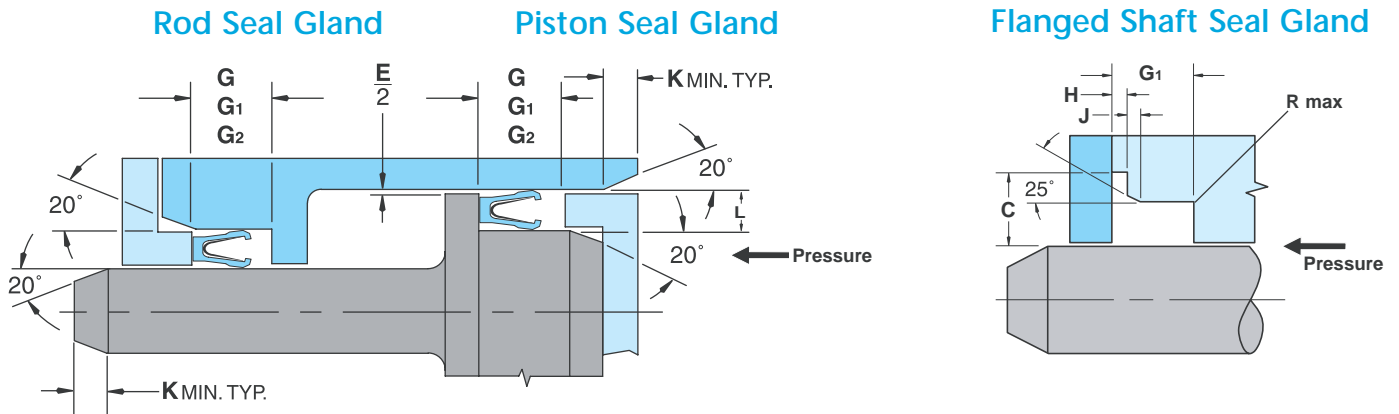

See page 11 for surface finish recommendations

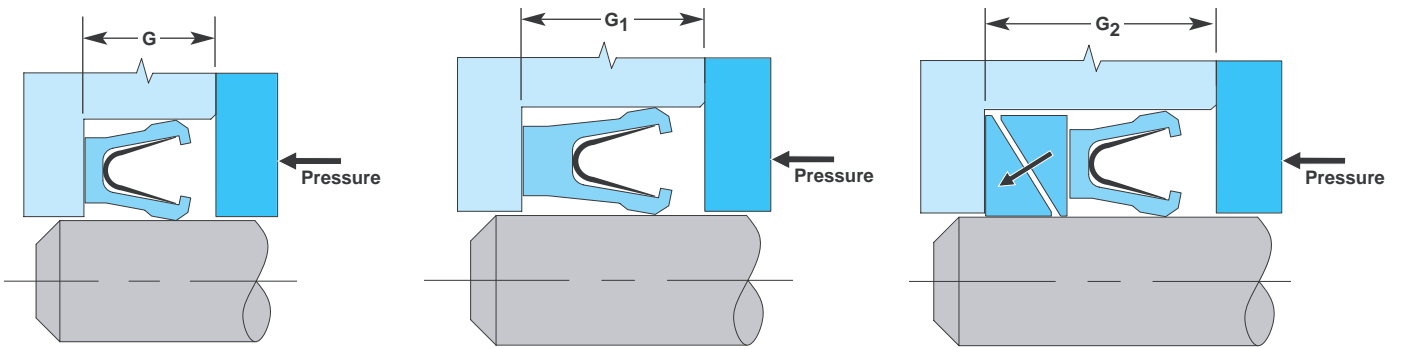

Gland width for standard OmniSeals

Gland width for extended heel OmniSeals

Gland width for standard OmniSeals plus back-up ring

## Radial Seal Gland Designs

X-Section No.	Nominal X-Section	L c/s in mm	G +0,3 -0,0	G <sub>1</sub> +0,3 -0,0	G <sub>2</sub> +0,3 -0,0	K Min.	C ± 0,13	H ± 0,05	J ± 0,13	E NOM (1)	R MAX	Shaft Tol.
3	1/8	3,07/3,12	4,8	6,0	7,7	2,4	5,5	0,70	1,30	0,15	0,20	-0,05
4	3/16	4,72/4,78	7,1	8,5	10,8	3,0	8,4	0,80	1,80	0,18	0,25	-0,06
5	1/4	6,05/6,12	9,5	12,1	14,7	4,0	11,6	1,20	2,30	0,20	0,50	-0,07

NOTE: Complete Rod and piston radia seal gland dimensional data for Mil./ind. and AS4716, 1/8"-1/4" X-sections available on request.

(1) See extrusion gap recommendations Page 10

## Alternate Gland Designs

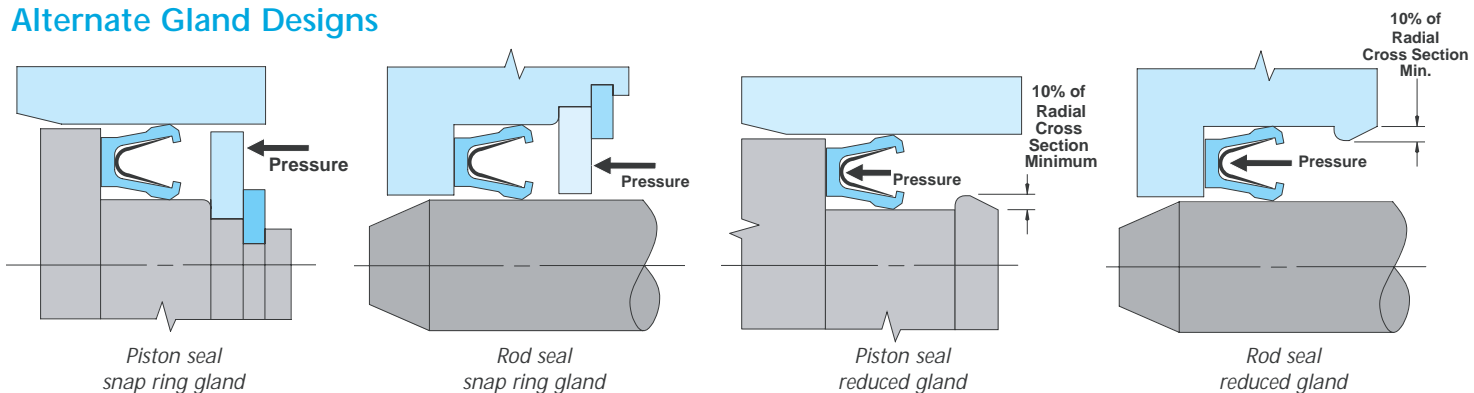

# Face Seals - OmniSeal 103A, 400A, APS & RACO® Series

## Face Seal

The OmniSeal RACO 1100A Face Seal employs a heavy duty, high load RACO spring with continuous spring contact along the entire sealing lip. This rugged seal is recommended for extreme static sealing conditions such as those involving cryogenic fluids, ultra high vacuum and

positive sealing of helium. The RACO® seal is also used dynamically in marine loading arm swivels and similar applications where high torque and clamping forces are employed. Larger cross sections and diameters are quite common with this seal design.



Face Seal For High Pressure	Inside Face Seal (Internally Pressurized)		Outside Face Seal (Externally Pressurized)	
	Shape			
Serie Part No.	103A 238	400A 228	103A 239	400A 229
Shape				
Serie Part No.	APS 738	Raco 348	APS 739	Raco 349

### Part Number System

238 4 0 - X2590 - A01 01 (23840-X2590-A0101)

- 238 — Seal Shape (see table above)
- 4 — Cross Section (see page 25)
- 0 — Hardware Indicator (always 0 for face seals)
- X2590 — Hardware Diameter (in example=259,0 mm)\*
- A01 — Jacket Material (see page 14)
- 01 — Spring Material (see page 15)

\* Hardware Diameter is OD for inside pressure, ID for outside pressure

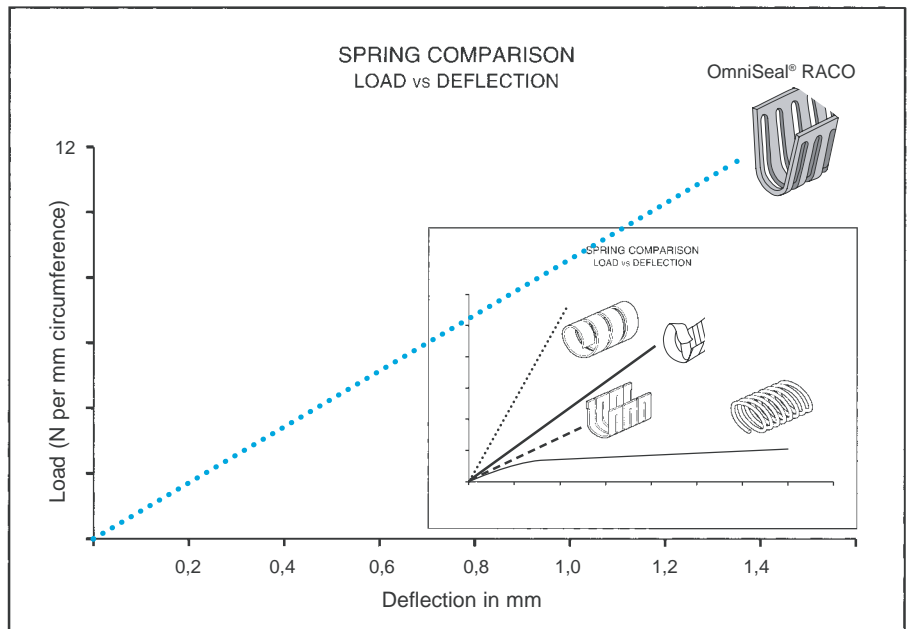

# OmniSeal Face Seals Series - Hardware

## Inside Face Seals

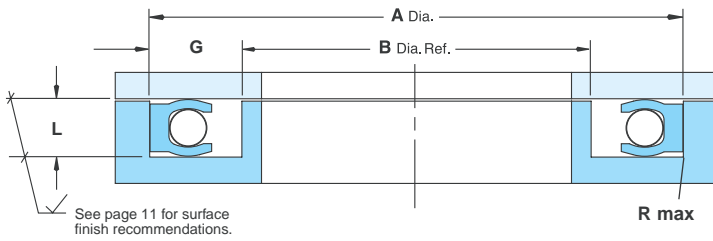

## Outside Face Seals

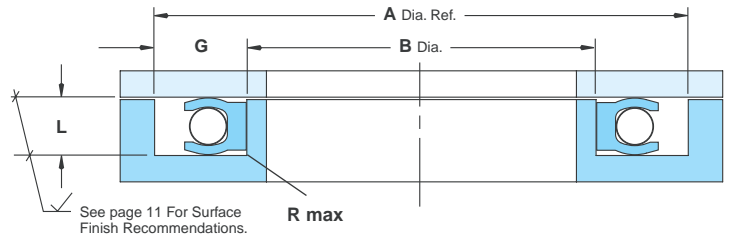

## Face Seal Gland Designs

Section No.	Nominal X-Section	L c/s in mm	G Min.	R MAX
1	1/16	1,42/1,47	2,4	0,10
2	3/32	2,26/2,31	3,6	0,10
3	1/8	3,07/3,12	4,8	0,20
4	3/16	4,72/4,78	7,1	0,25
5	1/4	6,05/6,12	9,5	0,50

## Minimal Seal Diameters

### OmniSeal RACO

Contact our Technical Service Department for information on sizes smaller than in table below.

Cross Section	Min. I.D.	Min. O.D.
2	14,5	19,0
3	19,0	25,5
4	35,0	38,0
5	95,0	102,0

### OmniSeal 103A, 400A & APS

Contact our Technical Service Department for information on sizes smaller than in table below.

For Face Seal designs

Cross Section	Min. I.D.
1	20
2	20
3	25
4	35
5	50

For Radial Seal designs

Cross Section	Min. I.D.
1	5
2	6
3	7,5
4	13
5	17

### OmniSeal RPII

Contact our Technical Service Department for information on sizes smaller than in table below.

Cross Section	Min. I.D.
3	30
4	30
5	50

For smaller sizes contact our Technical Support



# Typical Installations

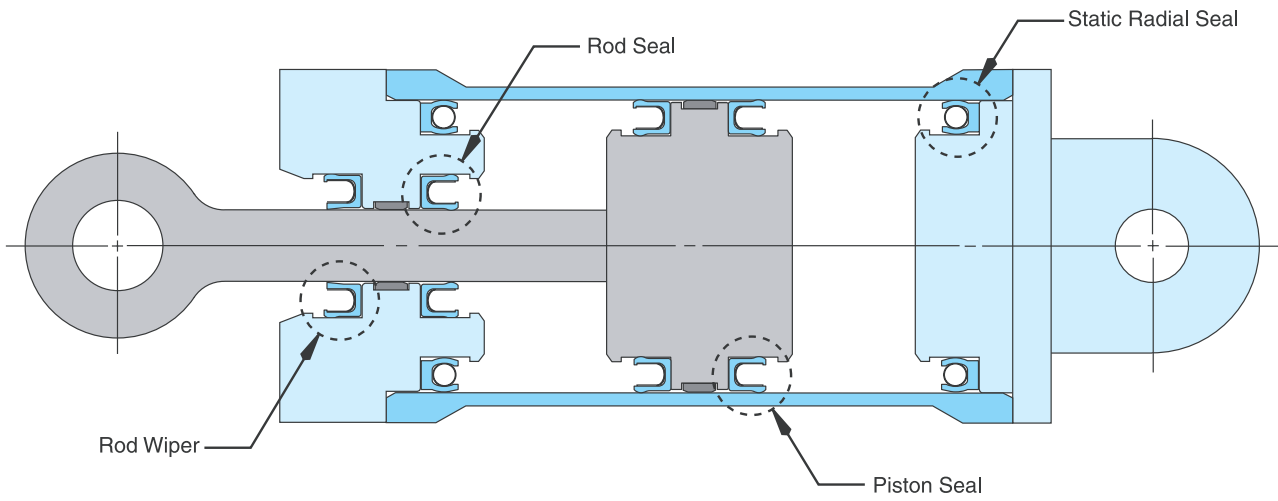

**Rotary Face Seal**

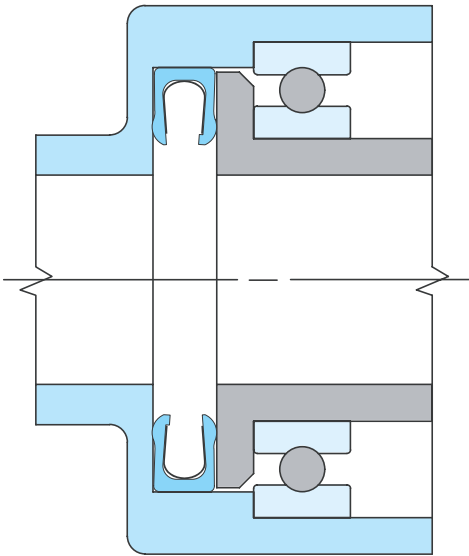

**Rotary Shaft Seal**

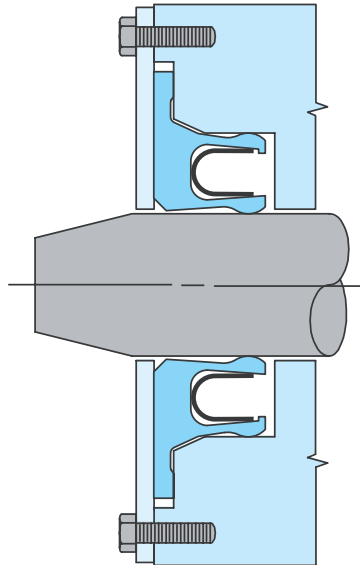

**Valve Stem Seal**

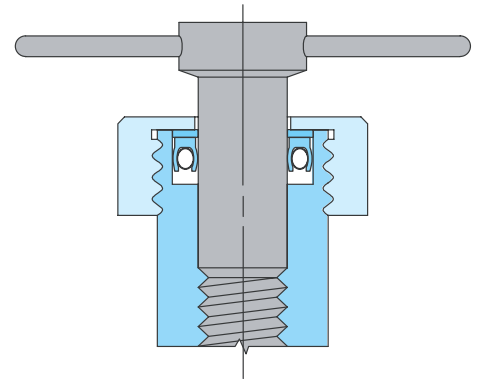

**Static Face Seal  
(Internal Pressure)**

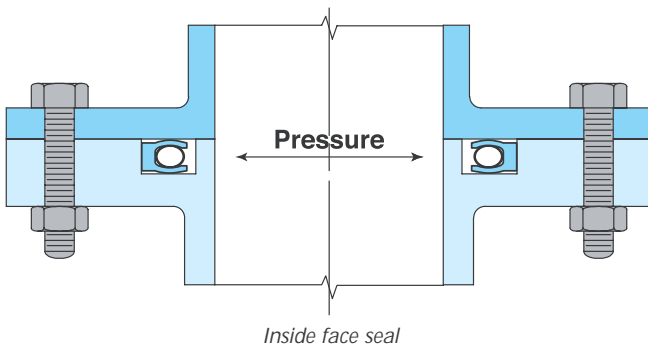

**Static Face Seal  
(External Pressure & Internal Vacuum)**

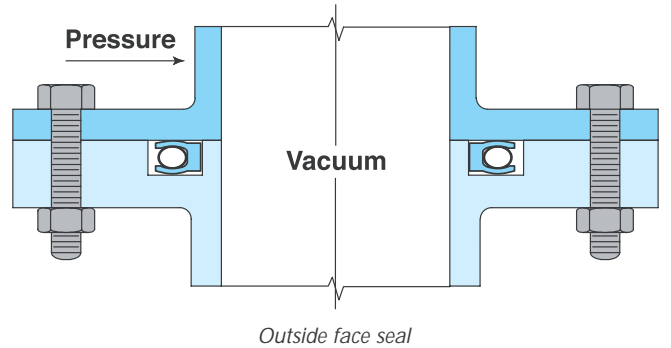



## Design Capabilities

For more than 30 years SGPPL has dedicated its engineering efforts to solving difficult and unique sealing problems. With each challenge we gained greater insight into the science of specialized sealing.

Today, aided by advanced 3-D modeling software and the latest

visualizing innovations, our team of skilled design engineers is exploring the next generation of sealing applications. Utilization of Finite Element Analysis (FEA) as a viable design and production tool facilitates higher productivity, design confidence, reduction in testing time and resultant cost savings.

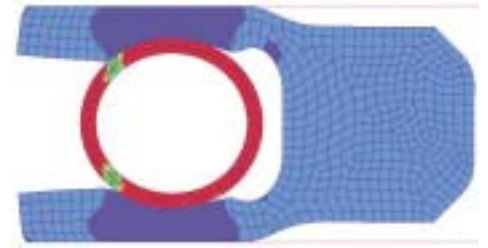

*Finite Element Analysis stress plot simulating seal jacket deflection.*

## Anti-Blowout Seal

This unique design has been used in the valve industry for over 40 years. In applications requiring the rod to disengage from the seal, the anti-blowout design prevents the dynamic sealing lip from deforming under pressure.

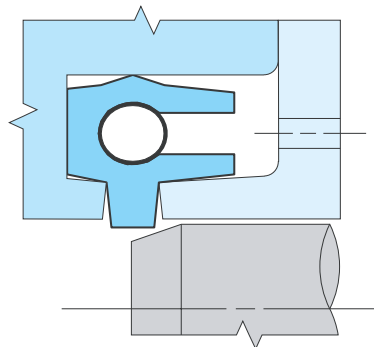

*Anti-blowout seal*

## Integral Piston Seal

For small diameter applications at moderate pressures, the integral piston seal is an innovative approach to reducing the number of precision machined metal parts and components. In addition to being easy to assemble, this design serves as a seal and as a guide bearing.

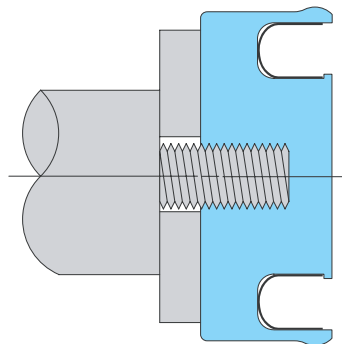

*Integral piston seal*

## Diaphragm Seals

This design combines a flexible disk and static face seal in a single unit. Diaphragm seals offer chemical equipment designers a simple yet advanced method for handling corrosive fluids in actuating valves and small metering pumps.

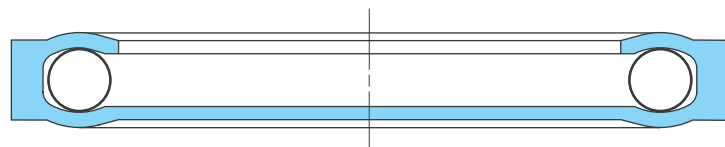

*Diaphragm seals*

## Machined Spring Face Seal

The machined spring seal is a solid ring of metal covered by a thin PTFE jacket. The solid spring is impermeable to light gases like hydrogen and helium, and provides extremely low leak rate sealing. It is also an excellent face seal for sealing hard vacuums.



*Machined spring face seal*



*Belleville spring seal*

## Belleville Spring Seals

Face seals energised with belleville washers provide high deflection without risk of the spring collapsing. Another advantage of bellevilles is that they can be manufactured in smaller diameters than most spring-energised seals.

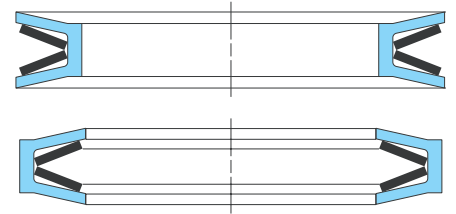

*Belleville spring seals*



*Bi-directional seals*

## Bi-Directional Seals

This versatile design combines two seals and a guide bearing into a one-piece component. The bi-directional seal is found in moderate temperature/pressure applications where simple assembly and quick replacement are required. When designed without an inside diameter it also serves as a floating piston.

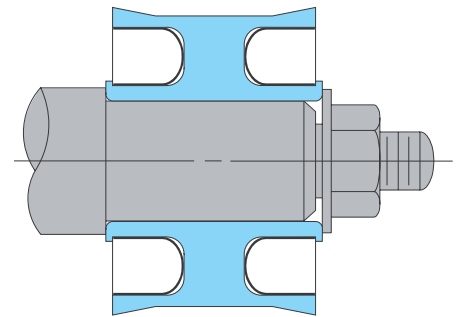

*Bi-directional seals*



*Sanitary seals*

## Sanitary Seals

The JS design shield the spring from the media to prevent entrapment in the spring and allow easier cleaning. Excellent in food filling and other dispensing equipment.

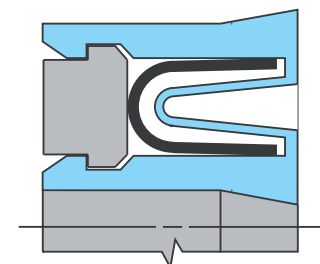

*JS seal*





OmniGasket

## OmniGasket

OmniGaskets are spring energised face seals retained in a metal plate designed to customer specifications. They offer the advantages of a ready-made seal groove (saving hardware design and machining cost), and easy changeout of the seals in the field.

These are two reasons why OmniGaskets are gaining wide acceptance in gas turbine engine and aerospace hydraulic applications.

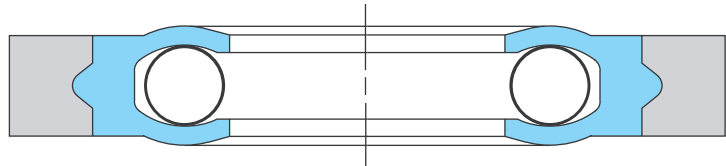

OmniGasket

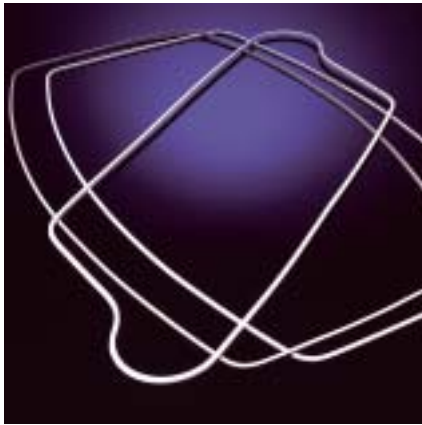

Formed seals

## Formed Seals

Formed seals are a unique specialty sealing product. SGPPL has the ability to manufacture most of the major seal cross sections in special shapes to fit the customer's hardware. Successful applications of formed seals include aerospace access doors and liquid heat exchangers.



High pressure seals

## High Pressure Seals with Back-Up Rings

A number of design options are available for high-pressure sealing problems. Back-up rings can be configured into most seal types to prevent extrusion of the jacket

material. Pressure actuated back-up rings are often recommended for closing multiple gaps or for dealing with hardware side loads.

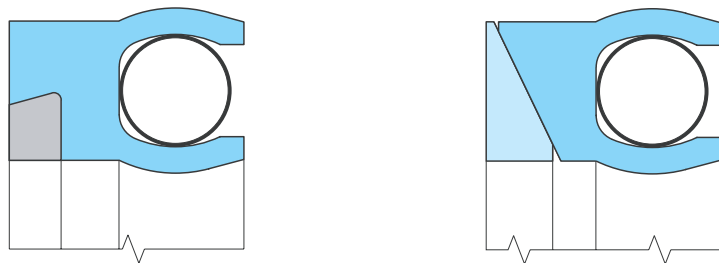

High pressure seals with back-up rings

# Other Seal Products



*Boss seals*

## Boss Seals

The metal Boss Seal is a pressure loaded, positive sealing device designed for service in port-to-tube fitting applications beyond the capabilities of elastomer O-rings.



*OmniLip seals*

## OmniLip™ Seals DynaLip® Seals

Saint-Gobain Performance Plastics designs and manufactures a complete line of rotary lip seals for high speed and/or high pressure rotary applications.

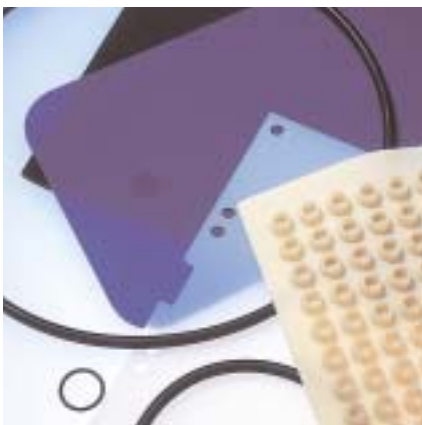

*OmniFlex seals*

## OmniFlex Seals

A proprietary fluoroelastomer material with performance factors that exceed perfluoroelastomer materials. Available in O-rings and standard and custom shapes.

## Hydraulic Seals

A product line of seals and scrapers designed specifically for hydraulic and pneumatic applications.



*Hydraulic seals*

## Resilient Metal Seals

Metal-O-Rings, Metal-C-Rings, Spring Energised Metal-C-Rings and machined V Rings designed for temperature from minus 260°C up to +1000°C. Available from Cross section < 1mm Up to 6,3 mm and diameters > 2 m.



*For complete information on these seal products, contact the nearest High Performance Seal location.*



## High Performance Seals Worldwide

Saint-Gobain  
Performance Plastics  
High Performance Seals  
7301 Oranewood Avenue  
Garden Grove, CA 92841-1411  
Tel.: (714) 995-1818  
Fax: (714) 688-2702

Saint-Gobain  
Performance Plastics  
22, Heiveldekens  
B-2550 Kontich  
Belgium  
Tel.: (+32) 3 458-2828  
Fax: (+32) 3 458-2669

Saint-Gobain  
Performance Plastics  
Saint-Gobain Norton KK  
10801-5, Haramura  
Suwa-gun, Nagano, 391-0106  
Japan  
Tel.: (+81) 266-79-6400  
Fax: (+81) 266-70-1001

			INJECTION MOLDING	AGRICULTURAL PLASTICS	NORGLIDE® BEARINGS	NORSLIDE®	OMNILIP™	OMNISEAL®	MELDIN®	RULON®	RAM EXTRUSION	MACHINED & MILLED COMPONENTS
<b>EUROPE</b>												
* Saint-Gobain Performance Plastics Pampus GmbH Willich • Germany	Phone: (49) 2154 600 Fax: (49) 2154 60310				•	•					•	•
* Saint-Gobain Performance Plastics N.V. Kontich • Belgium	Phone: (32) 34 58 28 28 Fax: (32) 34 58 26 69	•					•	•	•	•	•	•
Saint-Gobain Performance Plastics Asti Nanterre • France	Phone: (33) 1490 70205 Fax: (33) 1490 69762				•	•						
Saint-Gobain Performance Plastics Agrate Brianza (Mi) • Italy	Phone: (39) 03 96 50 070 Fax: (39) 03 96 52 736	•			•	•	•	•	•	•		
Saint-Gobain Performance Plastics Espana, S.A. Barcelona • Spain	Phone: (34) 93 682 8138 Fax: (34) 93 682 8143				•	•						
* Saint-Gobain Performance Plastics Espana, S.A. Logrono • Spain	Phone: (34) 94 14 86 035 Fax: (34) 94 14 37 095	•					•	•	•	•		•
<b>NORTH AMERICA</b>												
* Saint-Gobain Performance Plastics Corporation Wayne, New Jersey • USA	Phone: (1) 973-696-4700 Fax: (1) 973-696-4056				•	•					•	
* Saint-Gobain Performance Plastics Corporation Bristol, Rhode Island • USA	Phone: (1) 401-253-2000 Fax: (1) 401-253-1755	•							•	•	•	•
* Saint-Gobain Performance Plastics Corporation Mundelein, Illinois • USA	Phone: (1) 847-949-0850 Fax: (1) 847-949-0198									•		•
* Saint-Gobain Performance Plastics Corporation Garden Grove, California • USA	Phone: (1) 714-995-1818 Fax: (1) 714-688-2701						•	•				•
Saint-Gobain Performance Plastics Corporation Iztapalapa • Mexico	Phone: (5) 256-132-814	•			•	•			•	•		
<b>SOUTH AMERICA</b>												
* Saint-Gobain (Bearing & Wear Technology) Ceramicas Industrias Ltda. (Agricultural Plastics) Vinhedo-SP • Brazil	Phone: (55) 19 3876 8153 Phone: (55) 19 3876 8070 Fax: (55) 19 3876 8077	•	•	•	•	•	•	•	•	•		
<b>ASIA</b>												
* Saint-Gobain Norton KK Nagano • Japan	Phone: (81) 266 79 6400 Fax: (81) 266 70 1001	•	•	•	•	•	•	•	•	•		
* Saint-Gobain Performance Plastics Korea Co., Ltd. Seoul • South Korea	Phone: (82) 25 08 82 00 Fax: (82) 25 54 15 50	•	•	•	•	•	•	•	•	•		
* Saint-Gobain Performance Plastics Shanghai Co., Ltd. Shanghai • China	Phone: (86) 21 64 62 2800 Fax: (86) 21 64 62 27 81	•	•	•	•	•	•	•	•	•		
* Saint-Gobain Advanced Materials (Taiwan) Co., Ltd. Taipei • Taiwan	Phone: (886) 22 50 34 201 Fax: (886) 22 50 34 202	•	•	•	•	•	•	•	•	•		
* Grindwell Norton Ltd. Bangalore • India	Phone: (91) 80 847 2900 Fax: (91) 80 847 2905	•	•	•	•	•	•	•	•	•		
Saint-Gobain Advanced Materials (M) Sdn.Bhd Selangor Darul Ehsan • Malaysia	Phone: (60) 37 36 40 82/81 Fax: (60) 37 36 40 99	•	•	•	•	•	•	•	•	•		

\* Manufacturing Facilities

OmiLip™ is a trademark. Meldin®, Norglide®, Norslide®, OmniSeal® and Rulon® are registered trademarks.



**Limited Warranty:** For a period of 6 months from the date of first sale, Saint-Gobain Performance Plastics Corporation warrants this product(s) to be free from defects in manufacturing. Our only obligation will be to provide replacement product for any portion proving defective, or at our option, to refund the purchase price thereof. User assumes all other risks, if any, including the risk of injury, loss or damage, whether direct or consequential, arising out of the use, misuse, or inability to use this product(s). SAINT-GOBAIN PERFORMANCE PLASTICS DISCLAIMS ANY AND ALL OTHER WARRANTIES, EXPRESSED OR IMPLIED, INCLUDING THE IMPLIED WARRANTIES OF MERCHANTABILITY AND FITNESS FOR A PARTICULAR PURPOSE.

**NOTE:** Saint-Gobain Performance Plastics Corporation does not assume any responsibility or liability for any advice furnished by it, or for the performance or results of any installation or use of the product(s) or of any final product into which the product(s) may be incorporated by the purchaser and/or user. The purchaser and/or user should perform its own tests to determine the suitability and fitness of the product(s) for the particular purpose desired in any given situation.