



# **EUCLID REMANUFACTURED BRAKE SHOE CORE IDENTIFICATION**



# BRAKE SHOE IDENTIFICATION CHART



## Euclid Brake Shoe Number Index by FMSI Number

FMSI NO.	APPLICATION	CORE NO.	PAGE NO.
1252	15" x 5" Wagner Hydraulic		8
1279	15" x 3.5" Wagner Air		8
1280B	15" x 3.5" Wagner Hydraulic		7
1307	15" x 3.5" Meritor T Front		5
1308A	15" x 4" Wagner Air (512 shoe )		9
1308TT	15" x 4" Meritor Q Front	C1308	6
1308TT	15" x 4" Eaton Front	C1308E	6
1308TT	15" x 4" Meritor T Front	C1308T	5
1443TT	15" x 4" Eaton ES Front	C1443	7
4223A	16.5" x 5" Eaton (High Mount)	C4223	10
4311J	16.5" x 7" Eaton ( Low Mount )	C4311	10
4311J	16.5" x 7" Eaton ( High Mount )		10
4317G	16.5" x 6" Eaton ( Low Mount )	C4317	10
4317G	16.5" x 6" Eaton ( High Mount )	C4317H	10
4471B	18" x 7" Meritor Cast Iron	C4471	15
4504A	15" x 6" Meritor Lucas Hydraulic	C4504	7
4505A	15" x 7" Meritor Lucas Hydraulic	C4505	7
4514G	16.5" x 6" Meritor P		12
4514G	16.5" x 6" Meritor Q	C4514Q	13
4514G	16.5" x 6" Meritor Q w/relocated spring hole	C4514QR	14

FMSI NO.	APPLICATION	CORE NO.	PAGE NO.
4515	16.7" x 7" Meritor Cast Iron	C4515PC	14
4515E	16.5" x 7" Bendix		10
4515E	16.5" x 7" Fruehauf P	C4515F	11
4515E	16.5" x 7" Fruehauf XEM3	C4515F3	12
4515E	16.5" x 7" Meritor P	C4515P	12
4515G	16.5" x 7" Meritor for Fruehauf (F5)		12
4515G	16.5" x 7" Meritor Q	C4515Q	12
4515H	16.5" x 7" Meritor H.D. Q		14
4524B	16.5" x 5" Meritor P		12
4524B	16.5" x 5" Meritor Q	C4524Q	13
4524B	16.5" x 5" Meritor Q for 1.68" offset spider		14
4524B	16.5" x 5" Meritor Q w/relocated spring hole	C4524QR	14
4527B	18" x 7" Eaton Cast Iron	C4527	15
4528A	15" x 5" Meritor Lucas Hydraulic		7
4549C	16.5" x 4" Meritor Q		13
4551B	16.5" x 8.625" Fruehauf XEM3 LH		12
4551B	16.5" x 8.625" Fruehauf XEM3 RH		12
4551B	16.5" x 8.625" Meritor Q	C4551Q	13
4561	16.25" x 3.5" Meritor T		9
4591	12.25" x 7.5" Dexter "PQ"	C4591D	5

# BRAKE SHOE IDENTIFICATION CHART



## Euclid Brake Shoe Number Index by FMSI Number

FMSI NO.	APPLICATION	CORE NO.	PAGE NO.
4591	12.25" x 7.5" Eaton		4
4591	12.25" x 7.5" Standard Forge (closed roller end)	C4591S	5
4596	15" x 6" Wagner Hydraulic		8
4602	15" x 7" Meritor Stopmaster Wedge		9
4605	15" x 6" Meritor Stopmaster Wedge	C4605R	9
4615	15" x 5" Meritor Stopmaster Wedge		9
4644A	16.5" x 8" Meritor Q		13
4647	15" x 4" Kelsey Hayes / Gunite Hydraulic		7
4670	12.25" x 7.5" Meritor Q	C4670	5
4674	16.5" x 8.625" Eaton	C4674	10
4692	12.25" x 7.5" Standard Forge (open roller end)	C4692	4
4692	12.25" x 7.5" Dana Spicer "Fast Change II"	C4692FC2	4
4692	12.25" x 7.5" Dana Spicer "U"	C4692U	4
4693	15" x 4" Bendix		6
4701	16.5" x 7" Spicer XL	C4701	11
4702	15" x 4" Meritor Q Plus Front	C4702QP	8
4703	15" x 5" Meritor Q Plus Front	C4703QP	8
4704	15" x 6" Meritor Q Plus Front	C4704QP	8
4705	15" x 7" Meritor Q Plus Front		8

FMSI NO.	APPLICATION	CORE NO.	PAGE NO.
4706	15" x 8" Meritor Q Plus Front	C4706QP	8
4707	16.5" x 7" Meritor Q Plus	C4707QP	13
4707	16.5" x 7" Spicer XL II	C4707QP	13
4707	16.5" x 7" Meritor H.D. Q Plus	C4707QPM	13
4707	16.5" x 7" Meritor w/relocated springhole	C4707QPR	13
4708	16.5" x 7" Eaton for Rockwell		10
4709	16.5" x 7" Eaton ES	C4709	11
4709	16.5" x 7" Eaton ES II	C4709G2	11
4710	15" x 8.625" Meritor Q Plus	C4710QP	8
4710	15" x 8.625" IMT	C4710IMT	8
4711	16.5" x 8.625" Meritor Q Plus	C4711QP	14
4715	16.5" x 6" Meritor Q Plus	C4715QP	13
4717	15 x 8.625 Eaton Reduced Envelope	C4717	6
4718	16.5" x 8" Meritor Q Plus	C4718QP	14
4719	16.5" x 5" Eaton ES II	C4719	11
4720	16.5" x 5" Meritor Q Plus	C4720QP	13
4725	16.5" x 6" Eaton ES II	C4725	11
4726	16.5" x 8.625" Eaton ES II	C4726	11
4729	15" x 4" Eaton ES II	C4729	7

# BRAKE SHOE IDENTIFICATION CHART



## 12.25" Diameter

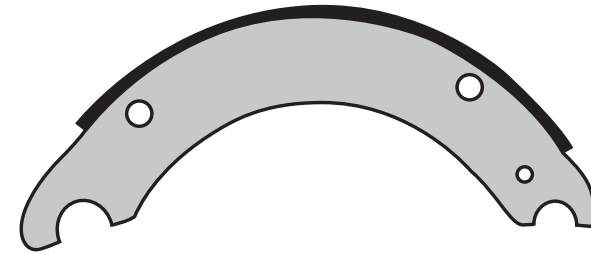

FMSI NO.	WIDTH	Euclid New Shoe PART NO.	Euclid Reman Core NO.	MFR.
4692	7.5"	E-2394A	C4692	Dana/Std. Forge

FMSI NO.	WIDTH	Euclid New Shoe PART NO.	Euclid Reman Core NO.	MFR.
4692	7.5"	E-10763	C4692FC2	Dana/Std. Forge

4692	7.5"	E-5303A	C4692U	Dana/Std. Forge
------	------	---------	--------	-----------------

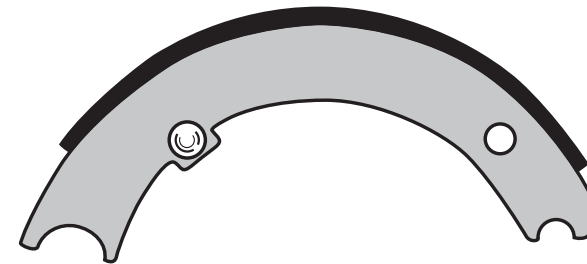

4591	7.5"	E-1398		Eaton
------	------	--------	--	-------

# BRAKE SHOE IDENTIFICATION CHART



## 12.25" Diameter

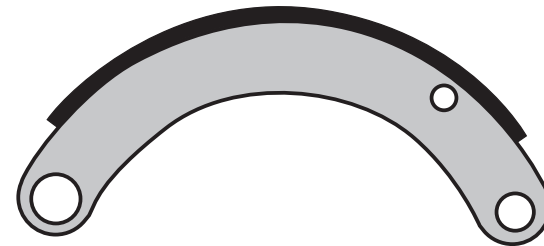
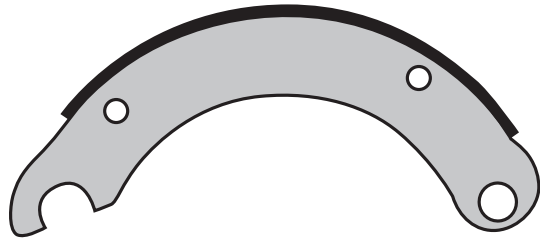

FMSI NO.	WIDTH	Euclid New Shoe PART NO.	Euclid Reman Core NO.	MFR.	FMSI NO.	WIDTH	Euclid New Shoe PART NO.	Euclid Reman Core NO.	MFR.
4591	7.5"	E-10878	C4591D	Dexter	4591	7.5"	E-2394	C4591S	Std. Forge

## 12.25" Diameter

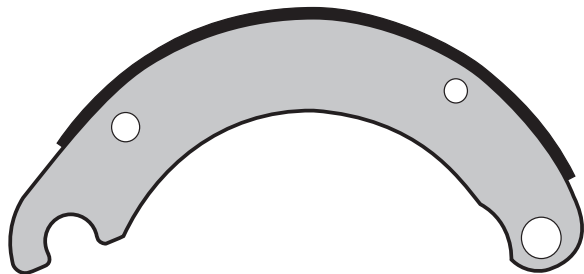

4670	7.5"	E-3491	C4670	Euclid Q
------	------	--------	-------	----------

## 15" Diameter

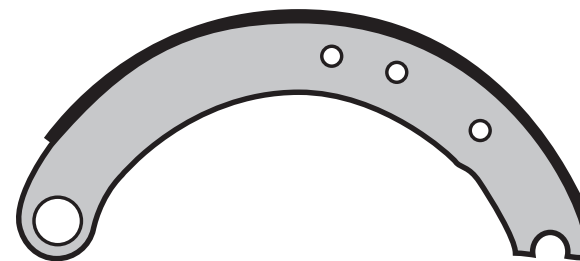

1307	3.5"	E-3438	C1307	Euclid T Brake
1308TT	4"	E-3439	C1308T	Euclid T Brake

# BRAKE SHOE IDENTIFICATION CHART



## 15" Diameter

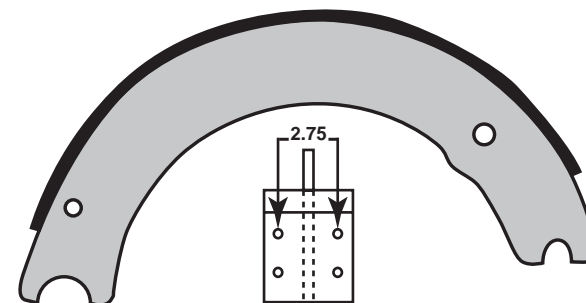
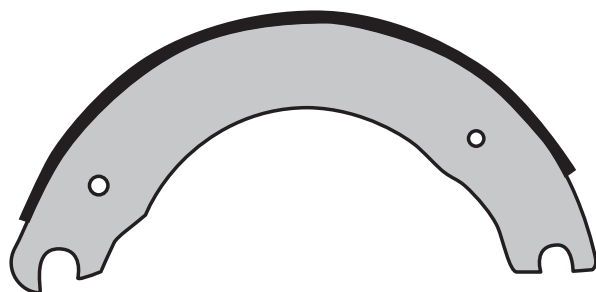

FMSI NO.	WIDTH	Euclid New Shoe PART NO.	Euclid Reman Core NO.	MFR.
1308TT	4"	E-5528	C1308Q	Euclid Q

FMSI NO.	WIDTH	Euclid New Shoe PART NO.	Euclid Reman Core NO.	MFR.
1308TT	4"	E-5126	C1308E	Eaton

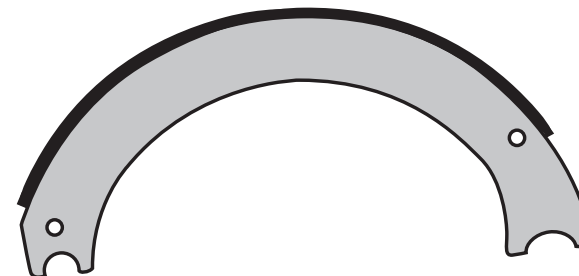
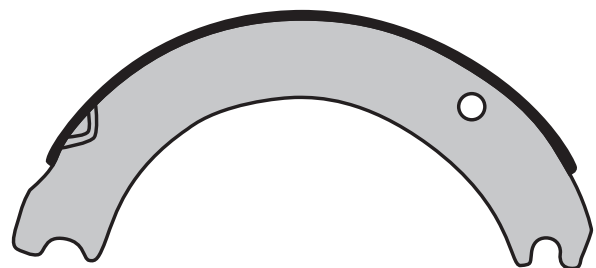

4693	4"	E-7230		Ford Cargo
------	----	--------	--	------------

4729	4"	E-11982	C4729	Eaton ES II
4717	8.625"	Not Available	C4717	Eaton Reduced Envelope

# BRAKE SHOE IDENTIFICATION CHART



## 15" Diameter

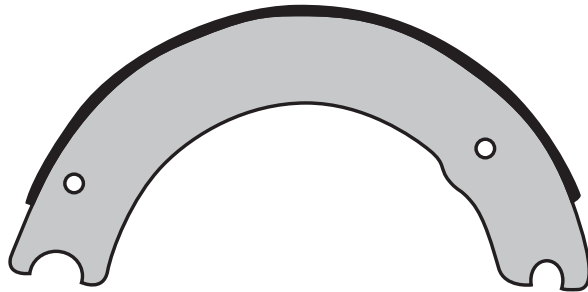

FMSI NO.	WIDTH	Euclid New Shoe PART NO.	Euclid Reman Core NO.	MFR.
1443TT	4"	E-9027	C1443	Eaton ES

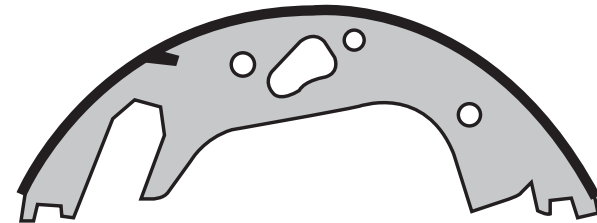

FMSI NO.	WIDTH	Euclid New Shoe PART NO.	Euclid Reman Core NO.	MFR.
4647	4"	E-2501		Gunite / Kelsey Hayes

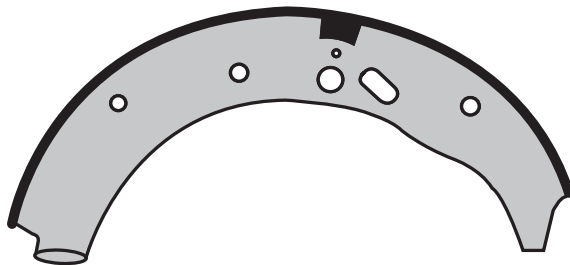

1280B	3.5"	E-4010		Wagner
-------	------	--------	--	--------

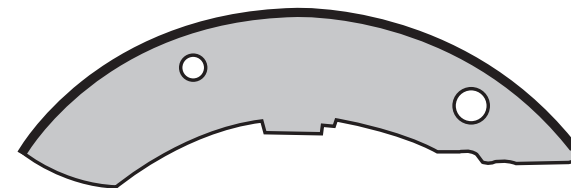

4528A	5"	E-4018		Lucas A2LS
4504A	6"	E-4019	C4504	Lucas A2LS
4505A	7"	E-4020	C4505	Lucas A2LS

# BRAKE SHOE IDENTIFICATION CHART



## 15" Diameter

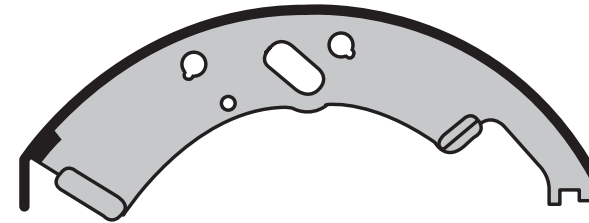
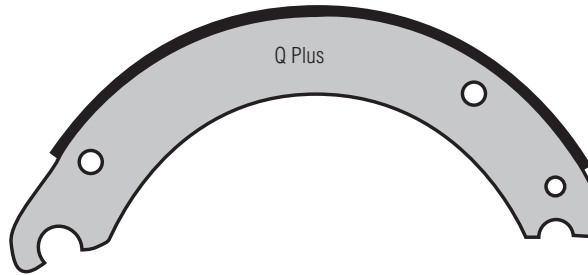

FMSI NO.	WIDTH	Euclid New Shoe PART NO.	Euclid Reman Core NO.	MFR.
4702	4"	E-9062	C4702QP	Euclid Q Plus
4703	5"	E-11453	C4703QP	Euclid Q Plus
4704	6"	E-11454	C4704QP	Euclid Q Plus
4705	7"	E-11455		Euclid Q Plus
4706	8"	Not Available	C4706QP	Euclid Q Plus
4710	8.625"	E-11456	C4710QP	Euclid Q Plus

FMSI NO.	WIDTH	Euclid New Shoe PART NO.	Euclid Reman Core NO.	MFR.
1252	5"	E-2529		Wagner
4596	6"	E-2498		Wagner

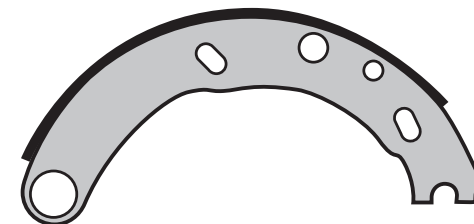
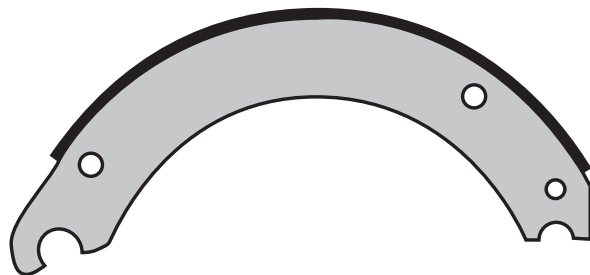

4710 | 8.625" | Not Available | C4710IMT<sup>1</sup> | IMT

1279 | 3.5" | E-2728 | | Wagner

<sup>1</sup> 4710 IMT for use on IMT axles— only. Shoe table has been repositioned, changing the contact points.



# BRAKE SHOE IDENTIFICATION CHART



## 15" Diameter

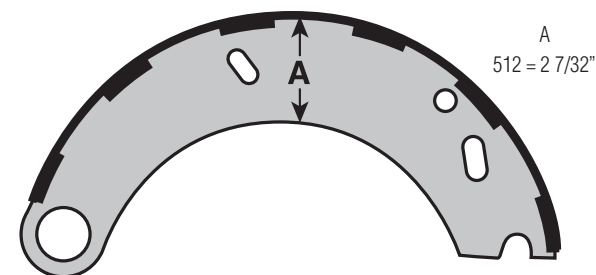
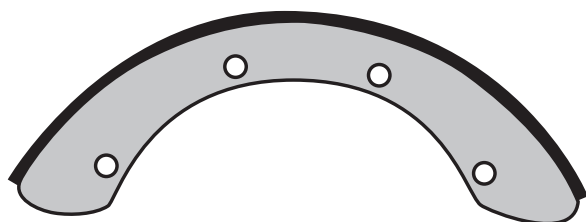

FMSI NO.	WIDTH	Euclid New Shoe PART NO.	Euclid Reman Core NO.	MFR.
4615	5"	E-2689		Stopmaster Wedge
4605	6"	E-1489	C4605R	Stopmaster Wedge
4602	7"	E-1139		Stopmaster Wedge

FMSI NO.	WIDTH	Euclid New Shoe PART NO.	Euclid Reman Core NO.	MFR.
1308A	4"	E-4785		Wagner 512

## 16.25" Diameter

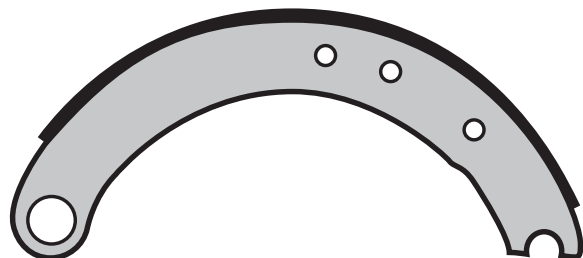

FMSI NO.	WIDTH	Euclid New Shoe PART NO.	Euclid Reman Core NO.	MFR.
4561	3.5"	E-3441		Euclid T Brake

# BRAKE SHOE IDENTIFICATION CHART



## 16.5" Diameter

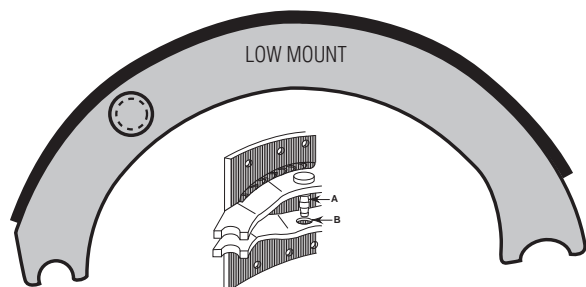

Spring Pin "A" is directly in line with Hole "B" in opposite Web.

FMSI NO.	WIDTH	Euclid New Shoe PART NO.	Euclid Reman Core NO.	MFR.
4317G	6"	E-1777	C4317	Eaton
4311J	7"	E-1778	C4311	Eaton
4674	8.625"	E-9054	C4674	Eaton

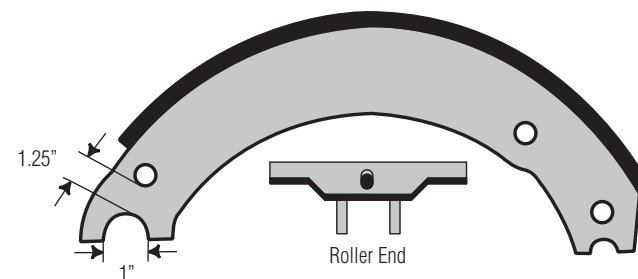

FMSI NO.	WIDTH	Euclid New Shoe PART NO.	Euclid Reman Core NO.	MFR.
4708	7"	E-8922	C4708R	Eaton Q Retrofit

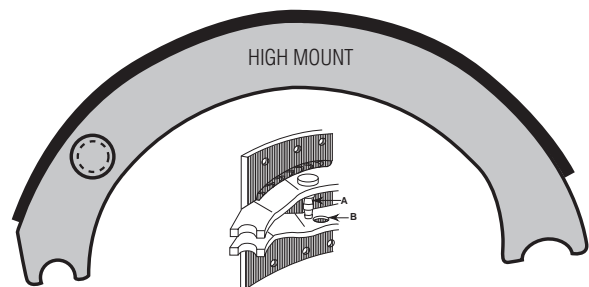

Spring Pin "A" is located farther toward the end of the shoe.

4223A	5"	E-2474		Eaton
4317G	6"	E-9509	C4317H	Eaton
4311J	7"	E-2819		Eaton

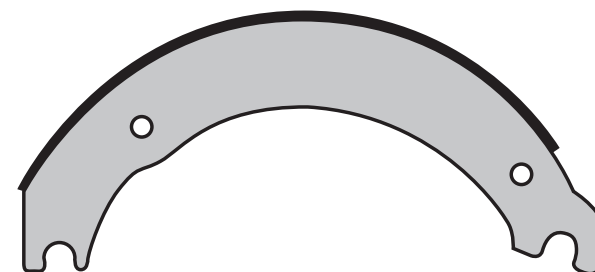

4515E	7"	E-7236		Bendix
-------	----	--------	--	--------

# BRAKE SHOE IDENTIFICATION CHART



## 16.5" Diameter

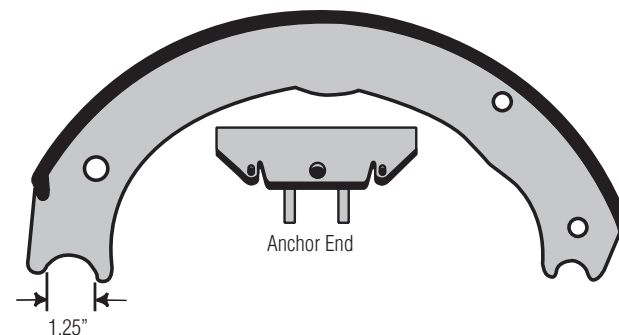
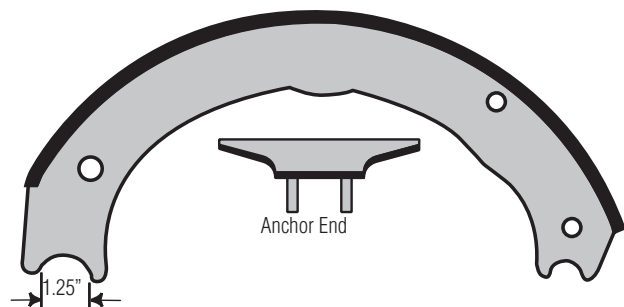

FMSI NO.	WIDTH	Euclid New Shoe PART NO.	Euclid Reman Core NO.	MFR.
4719	5"	E-10270	C4719	Eaton ES II
4725	6"	E-10271	C4725	Eaton ES II
4709	7"	E-10272	C4709G2	Eaton ES II
4726	8.625"	E-10273	C4726	Eaton ES II

FMSI NO.	WIDTH	Euclid New Shoe PART NO.	Euclid Reman Core NO.	MFR.
4709	7"	E-5480	C4709	Eaton ES

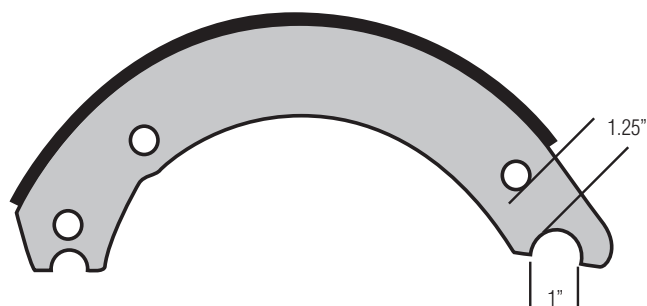

4701	7"	Not Available	C4701 <sup>2</sup>	Dana
------	----	---------------	--------------------	------

4515E	7"	Not Available	C4515F	Fruehauf P
-------	----	---------------	--------	------------

<sup>2</sup> Not acceptable as a core return when purchasing 4515Q reman shoes.

# BRAKE SHOE IDENTIFICATION CHART



## 16.5" Diameter

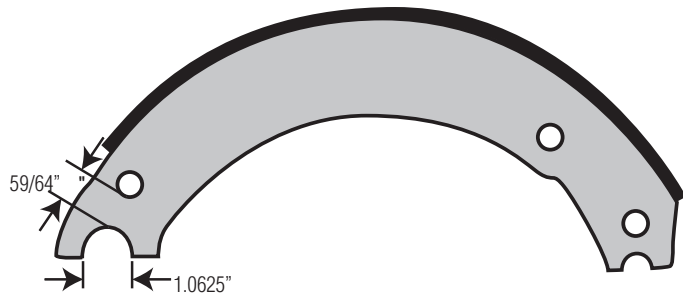

FMSI NO.	WIDTH	Euclid New Shoe PART NO.	Euclid Reman Core NO.	MFR.
4515E	7"	E-3920	C4515F3	Fruehauf XEM 3
4551B	8.625"	E-3713		Fruehauf XEM 3 LH
4551B	8.625"	E-3714		Fruehauf XEM 3 RH

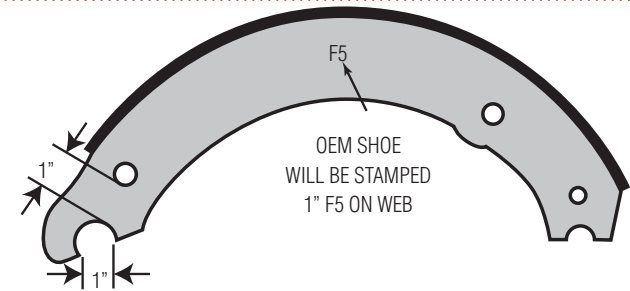

FMSI NO.	WIDTH	Euclid New Shoe PART NO.	Euclid Reman Core NO.	MFR.
4515G	7"	E-6075		Euclid/Fruehauf XEM3

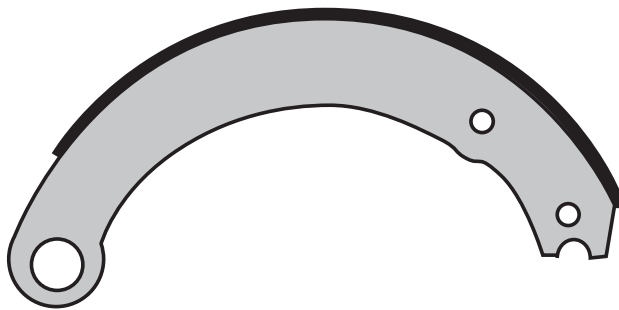

4524B	5"	E-2687		Euclid P
4514G	6"	E-2684		Euclid P
4515E	7"	E-2241	C4515P	Euclid P

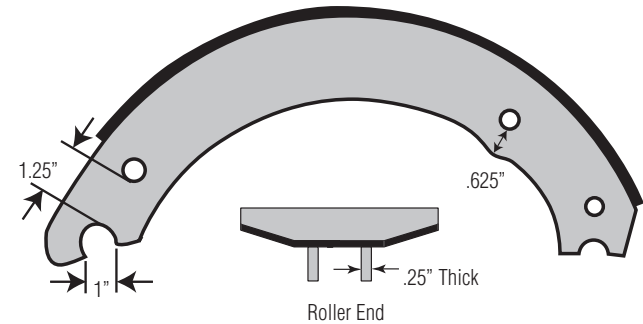

4524B	5"	E-3303	C4524Q	Euclid Q
4514G	6"	E-3304	C4514Q	Euclid Q
4515G	7"	E-2778	C4515Q	Euclid Q
4644A	8"	Not Available		Euclid Q
4551B	8.625"	E-3522	C4551Q	Euclid Q

# BRAKE SHOE IDENTIFICATION CHART



## 16.5" Diameter

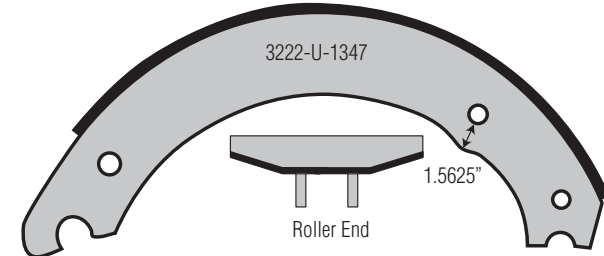
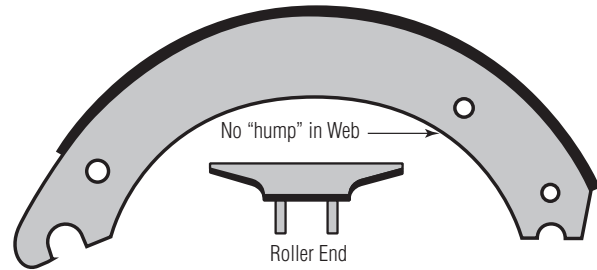

FMSI NO.	WIDTH	Euclid New Shoe PART NO.	Euclid Reman Core NO.	MFR.
4720	5"	E-10854	C4720QP	Euclid Q Plus
4715	6"	E-10847	C4715QP	Euclid Q Plus
4707	7"	E-5503	C4707QP	Euclid Q Plus
4707	7"	E-5503	C4707QP	Spicer XLII
4718	8"	E-10850	C4718QP	Euclid Q Plus
4711	8.625"	E-10844	C4711QP	Euclid Q Plus

FMSI NO.	WIDTH	Euclid New Shoe PART NO.	Euclid Reman Core NO.	MFR.
4524B	5"	E-3823	C4524QR	Euclid Q Mack
4514G	6"	E-9780	C4514QR	Euclid Q Mack

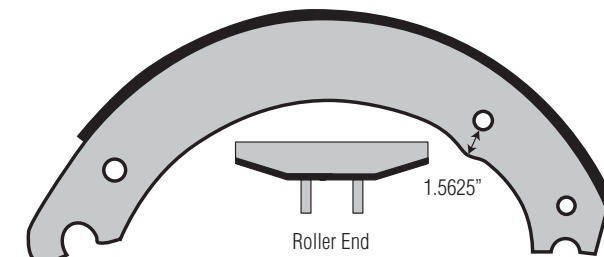
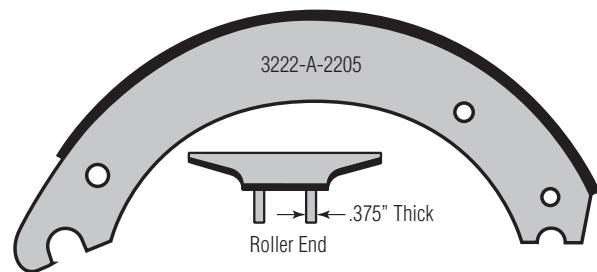

4707 | 7" | Not Available | C4707QPM | Euclid Q Plus HD Shoe

4707 | 7" | Not Available | C4707QPR | Euclid Q Plus

# BRAKE SHOE IDENTIFICATION CHART



## 16.5" Diameter

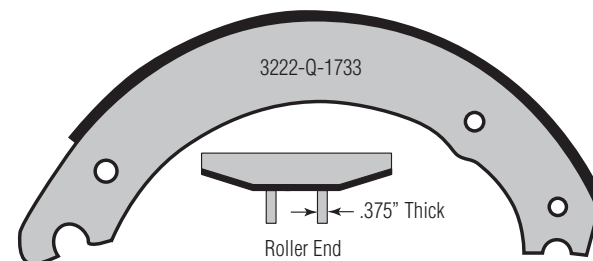
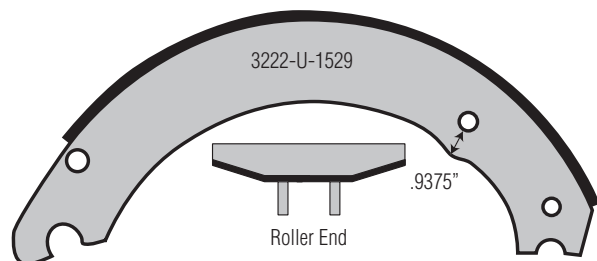

FMSI NO.	WIDTH	Euclid New Shoe PART NO.	Euclid Reman Core NO.	MFR.
4524B	5"	Not Available		Euclid Q (1.68" offset spider)

FMSI NO.	WIDTH	Euclid New Shoe PART NO.	Euclid Reman Core NO.	MFR.
4515H	7"	E-5092		Euclid Q Mack HD Shoe



FMSI NO.	WIDTH	Euclid New Shoe PART NO.	Euclid Reman Core NO.	MFR.
4515	7"	Not Available	C4515PC	Euclid Cast Iron

# BRAKE SHOE IDENTIFICATION CHART



## 18" Diameter

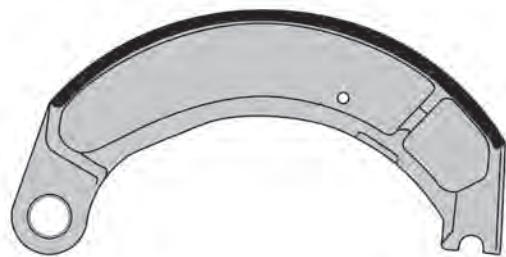

FMSI NO.	WIDTH	Euclid New Shoe PART NO.	Euclid Reman Core NO.	MFR.
4471B	7"	E-4902	C4471	Euclid Cast Iron

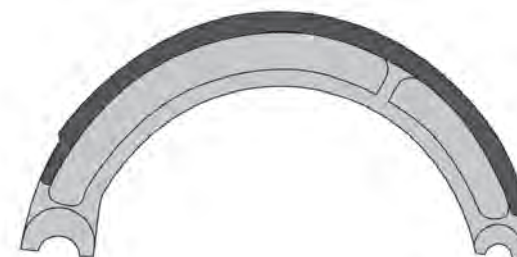

FMSI NO.	WIDTH	Euclid New Shoe PART NO.	Euclid Reman Core NO.	MFR.
4527B	7"	E-2801	C4527	Eaton Cast Iron

# BRAKE SHOE IDENTIFICATION CHART



## Typical Brake Shoe

### Damage Shown Below Indicates AN UNACCEPTABLE CORE

#### VISUAL INSPECTION PROCEDURE for Brake Shoes with Anchor Pin Slots

Look for damage in the areas shown here. Scrap the shoe if any of these conditions exist.

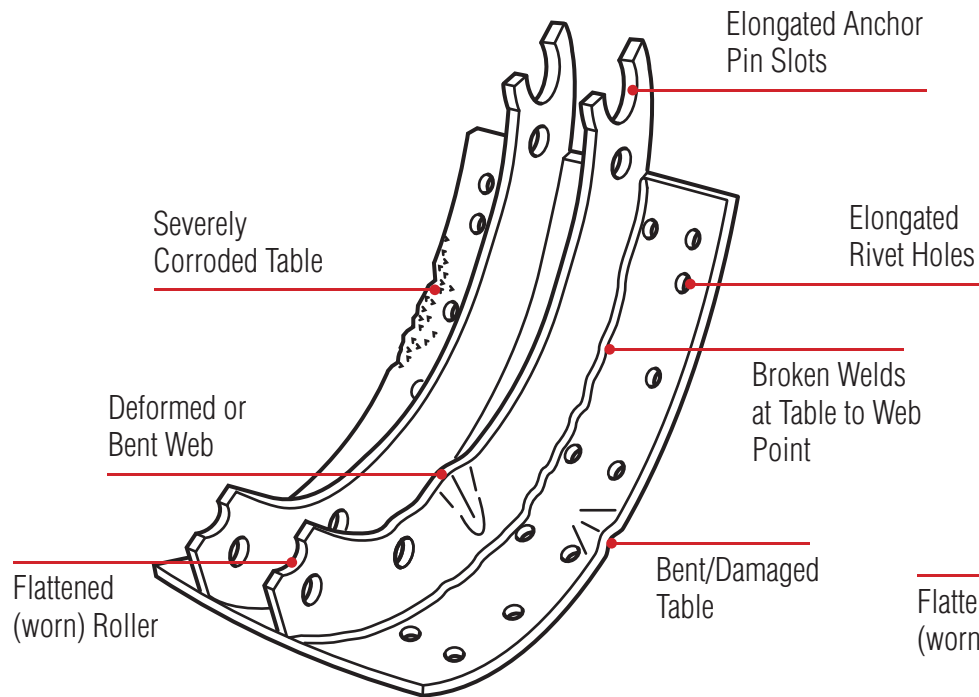

#### VISUAL INSPECTION PROCEDURE for Brake Shoes with Anchor Pin Holes

Look for damage in the areas shown here. Scrap the shoe if any of these conditions exist.

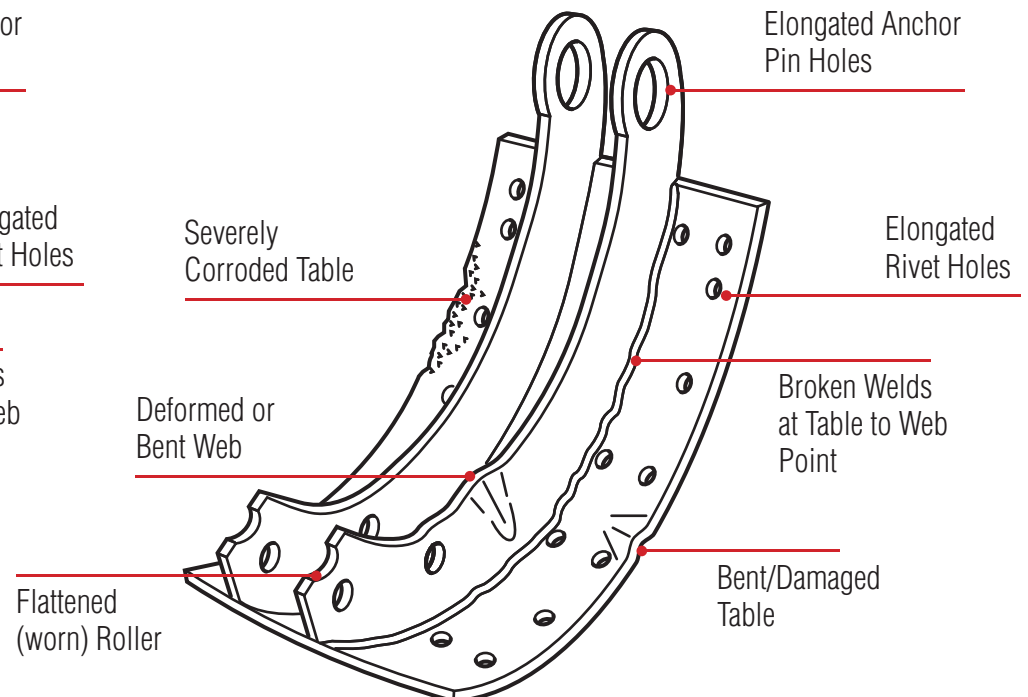



# REMANUFACTURED BRAKE SHOES WITH PLATINUMSHIELD™ II COATING

## "BRAKE-THROUGH" TECHNOLOGY SOLVES THE INDUSTRY'S RUST-JACKING PROBLEM!



PlatinumShield™ II coating. It's one very big Meritor idea that results in even bigger dividends for you and the whole trucking industry.

Why? Because Meritor reman brake shoes with PlatinumShield II, the second-generation brake shoe coating that features a stronger formula, provide unsurpassed resistance to rust-jacking and corrosion – while extending the life of your brakes.

Today's harsher liquid chemicals used in winter road solvents to melt ice and snow have intensified the rust-jacking that has cut short brake shoe life and added unnecessary costs.



But our PlatinumShield II, the second-generation coating of this scientific breakthrough by Meritor brake engineers, has solved the problem once and for all.

As a result, Meritor reman brake shoes with PlatinumShield II coating deliver everything you expect from a worldwide brake leader. Including our 3-Year/300,000-Mile warranty against rust-jacking. So, unlike the competition's, our 3-year reman brake shoes actually last three full years.

Now, those are the kind of results that every fleet wants. Again and again.

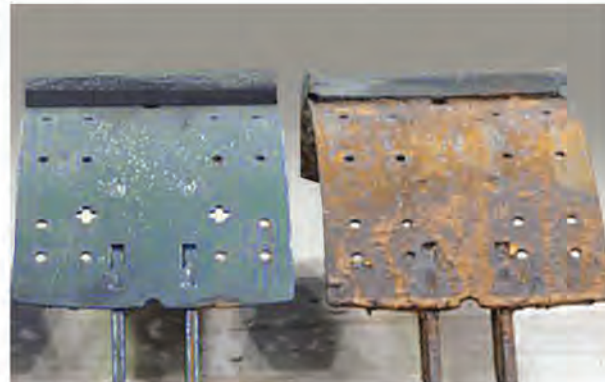

Results after salt spray test.  
(Left) PlatinumShield II coating, (right) Competitor G.

### How Did Our Brake Engineers Solve This Longtime Rust-Jacking Problem?

In order to develop a real-world solution, our brake experts re-created actual road conditions. Unlike in most testing, we first took lined brake shoes and subjected them to brake applications on a dynamometer – before we subjected them to a salt spray test. In this approach, brake shoes reach the salt spray test with wear and tear that more closely approximates actual highway results.

Next, in our ASTM B-117 Salt Spray Test, brake shoes were sprayed with a bath made of modern anti-icing road solvents and salt water for 408 hours. We observed how rust forms on brake shoe tables and tested the corrosion resistance of countless paints and coatings.

Of all the brake shoes and coatings tested, we found that PlatinumShield II does the best job of protecting the shoe table by preventing micro-abrasions, so rust-jacking simply does not occur during the expected life of the brake shoe. In fact, the PlatinumShield II coating meets our list of desired criteria:

- Rates higher than 8 on the ASTM scale
- Unlike competitors', Meritor reman brake shoes with PlatinumShield II coating offer a 3-Year/300,000-Mile warranty against rust-jacking

### Want Extended Brake Life And Reduced Stopping Distances Combined?

No other reman brake shoe delivers protection from rust-jacking for the full brake life like Meritor reman brake shoes with PlatinumShield II coating. And now, no other reman brake shoe will deliver such a combination of stopping power and corrosive protection. Because Meritor reman brake shoes with PlatinumShield II coating now also feature new Meritor Reduced Stopping Distance (RSD) friction materials. It's simply the best braking combination available in the aftermarket!

# BRAKE SHOE IDENTIFICATION CHART



**MERITOR WABCO**  
Safety. Strength. Efficiency. Smart™

**Mascot**  
Truck Parts  
a **MERITOR** brand

**EUCLID**

**MERITOR**

**MERITORPARTSONLINE.COM**  
Your 24/7/365 access to Meritor®, Euclid, Mascot and Meritor WABCO parts ordering, plus real-time pricing, parts comparisons and in-depth technical information.  
©2013 Meritor, Inc. meritor.com





**Meritor Heavy Vehicle Systems, LLC**  
7975 Dixie Highway  
Florence, KY 41042 USA

**For more information:**

**U.S. 888-725-9355**

**Canada 800-387-3889**

**MeritorPartsOnline.com**

**meritor.com**

Information contained in this publication is in effect at the time the publication was approved for printing and is subject to change without notice or liability. Euclid Heavy Vehicle Systems, LLC, reserves the right to revise the information presented or discontinue the production of parts described at any time.

Litho in USA Revised 03-13  
A-906 (FLOA)  
©2013 Meritor, Inc.