

---

# EVOLUTION

---



## EVOLUTION e SERIES AMPLIFIERS

302e, 402e AND 2250e STEREO  
403e AND 3250e THREE-CHANNEL  
400e, 600e AND 900e MONAURAL

OWNER'S REFERENCE

**KRELL**  
THE LEADER IN AUDIO ENGINEERING

---

**Evolution 302e, 402e, 2250e, 403e, 3250e, 400e 600e and 900e Power Amplifiers  
Owner's Reference, V1.0**

Krell Industries, LLC  
45 Connair Road  
Orange, CT 06477-3650 USA

TELL 203-298-4000  
FAX 203-891-2028  
E-MAIL [sales@krellonline.com](mailto:sales@krellonline.com)  
WEBSITE <http://www.krellonline.com>



This product complies with the EMC directive (89/336/EEC) and the low-voltage directive (73/23/EEC).

This CLASS 1 apparatus must be connected to a MAINS socket outlet with a protective earthing connection.

## **IMPORTANT SAFETY INSTRUCTIONS**

1. *Read Instructions.*
2. *Keep these Instructions.*
3. *Heed all Warnings.*
4. *Follow all Instructions.*
5. *Do not use this apparatus near water.*
6. *Clean only with a dry cloth.*
7. *Do not install near any heat sources such as radiators, heat registers, stoves, or other apparatus (including amplifiers) that produce heat.*
8. *Unplug this apparatus during lightning storms or when unused for long periods of time.*
9. *Refer all servicing to qualified service personnel. Servicing is required when the apparatus has been damaged in any way, such as a power-supply cord or plug is damaged, liquid has been spilled or objects have fallen into the apparatus, the apparatus has been exposed to rain or moisture, does not operate normally, or has been dropped.*
10. *An Evolution e Series amplifier must be placed on a firm, level surface where it is not exposed to dripping or splashing.*
11. *The ventilation slots on the top of every Evolution e Series amplifier, the ventilation slots on the back of the Evolution 302e and 400e amplifier, and the space underneath every Evolution e Series amplifier must be unobstructed at all times during operation. Do not place flammable material above or beneath an Evolution e Series amplifier.*
12. *Before making connections to an Evolution e Series amplifier, ensure that the power is off and other components are in mute or stand-by mode. Make sure all cable terminations are of the highest quality, free from frayed ends, short circuits, or cold solder joints. Be especially careful when connecting to terminals marked ⚡ which may have hazardous voltages on them during operation.*
13. **THERE ARE NO USER SERVICEABLE PARTS INSIDE AN EVOLUTION AMPLIFIER.**

Please contact Krell if you have questions not addressed in this guide.

This product is manufactured in the United States of America. Krell® is a registered trademark of Krell Industries, LLC, and is restricted for use by Krell Industries, LLC, its subsidiaries, and authorized agents. CAST™, Evolution CAST™, and Krell Current Mode™ are trademarks of Krell Industries, LLC. All other trademarks are registered to their respective companies.



---

# Contents

*List of Illustrations, page 4*

*A Letter from Krell, page 5*

**SECTION ONE: Evolution e Series Amplifier Features and Technology, page 6**

*Features, Revolutionary Krell CAST Technology,  
Definition of Terms*

**SECTION TWO: Unpacking and Placement, page 11**

*Opening the Evolution e Series Amplifier Shipping Carton*

**SECTION THREE: Anatomy of the Evolution e Series Amplifier, page 13**

*Front Panel Description, and Back Panel Description*

**SECTION FOUR: Connecting an Evolution e Series Amplifier to Your System, page 21**

*CAST Connections, Balanced Connections, Single-ended Connections,  
Evolution DC Protection Circuitry/Using Tube Preamplifiers, Connection Steps*

**SECTION FIVE: Evolution e Series Amplifier Operation, page 23**

*On/Off and Stand-by Operation*

**SECTION SIX: Troubleshooting System Noise, page 24**

*How to Evaluate e Series Amplifier Operation, Error Codes*

**SECTION SEVEN: Questions and Answers, page 26**

**WARRANTY, page 27**

**RETURN AUTHORIZATION PROCEDURE, page 29**

**SPECIFICATIONS, page 30**

---

## List of Illustrations

**Figure 1, page 13**

*Evolution e Series Amplifier Front Panel*

**Figure 2, page 15**

*Evolution 302e Back Panel*

**Figure 3, page 16**

*Evolution 402e Back Panel*

**Figure 4, page 17**

*Evolution 403e Back Panel*

**Figure 5, page 18**

*Evolution e Series Monaural Amplifier Back Pane*

**Figure 6, page 20**

*Evolution 2250e Back Panel*

**Figure 7, page 21**

*Evolution 3250e Back Panel*

**Figure 8, page 28**

*Connection Diagram*

# A Letter from Krell Industries

---

Dear Audio Enthusiast,

Thank you for your purchase of a Krell Evolution e Series amplifier. No component in an audio system contributes more to the full range of musical expression than a power amplifier. The seemingly impossible tasks of simultaneously conveying music's subtle emotional cues and intense dynamic passages rest squarely on its shoulders. In our quest for amplifiers that deliver absolute truth in music reproduction, we present the Evolution e Series. This next generation of Evolution Amplifiers, "e", short for enhanced, represent a defining moment in Krell design, joining awesome current capability with a newly refined, ultra-linear circuit topology and environmentally friendly operation.

Krell amplifiers are best known for their ability to drive any loudspeaker to sound its best, without regard to impedance, efficiency, or driver style. It is linearity, an amplifier's ability to output an exact duplicate of the input signal, which is the ultimate measure of that amplifier's worth. Krell designs toward the common goal of linearity, through the rigorous application of Krell design principles that focus our efforts on four major performance factors: distortion, bandwidth, output impedance and current capability. The Evolution e Series excels in each of these areas, delivering supreme accuracy from whisper level to astounding, awe inspiring amounts of power with grace and elegance.

## **BETTER SOUND**

Building on the unique Active Cascode Topology foundation of the Evolution Series, the e Series amplifiers feature more precisely balanced current sharing among the seven sets of Active Cascode Quartets that make up the output stage. This greater precision elevates an already impressive performance envelope and provides greater amplifier reliability. Audible at all volume levels, this improvement is independent of load current. Although negative feedback in the Evolution amplifiers was already extremely low, a mere 14 dB several orders of magnitude lower than other manufacturers' power amplifiers modifications to the feedback circuitry allow for more ideal operation completely independent of the signal level. The results are greatly enhanced inner detail and micro-dynamics with smoother high frequency response.

An intense upgrade to the power supply includes a number of improvements. There is now a separate transformer for the digital power supplies. Not only does this facilitate greatly reduced power consumption in standby, but it provides still better isolation between the digital and analog power supplies. The high-current and high-voltage analog supplies have additional noise filtration circuitry to reduce high-frequency switching noise from the rectifiers. The high-current power supplies also have more reservoir capacitance than before (anywhere from 10-50% more, depending upon the model). Finally, the power supply circuit board has been redesigned for better isolation between the incoming AC power and the DC power supplies.

## **LESS HEAT, LOWER ENERGY CONSUMPTION**

A new green standby mode reduces standby power draw dramatically. Standby power draw for all Evolution e Series amplifiers has been reduced to 2W. As an example, the Evolution 402e power draw drops to 2W from 260W as compared to the Evolution 402 - a reduction of 99% in energy draw and a huge drop in heat output. The power indicator ring now glows green to indicate the new energy efficient mode.

We hope that you enjoy your new Evolution e Series amplifier.

Sincerely,

Krell Industries, LLC

## Evolution e Series Amplifier Features and Technology

This section describes the innovative features and technology of the Evolution e Series amplifiers, and defines CAST and other key terms used in this reference. There are seven amplifier models in the Evolution e Series: the 302e Stereo Power Amplifier, the 402e Stereo Power Amplifier, the 2250e Stereo Power Amplifier, the 403e Three-channel Power Amplifier, the 3250e Three-channel power Amplifier, the 400e Monaural Power Supply, the 600e Monaural Power Amplifier, and the 900e Monaural Power Amplifier.

### Features

Evolution e Series 302e, 402e, 403e, 400e, 600e, and 900e amplifiers are designed with a signal path that incorporates Krell Current Mode and CAST circuitry.

All amplifiers feature massive power supplies. The power supply makes use of extensive electrical and magnetic shielding to keep radiated interference out of critical amplifier circuits.

The Evolution 302e and Evolution 400e are equipped with a 3000 VA power supply. The Evolution 2250e and Evolution 3250e are equipped with a 2500 VA power supply. The Evolution 402e and Evolution 600e are equipped with a 4400 VA power supply, and the Evolution 403e and Evolution 900e house 6000 VA power supplies.

Internal high-current line conditioning circuitry filters RF noise on the AC mains, as well as compensating for asymmetrical power waveforms and DC on the mains.

Advanced microprocessor control monitors critical operational parameters. In the event of a problem, the power status indicator will flash, indicating a potential fault.

---

## Revolutionary Krell CAST Technology

Current Audio Signal Transmission, termed CAST, is a revolutionary method of connecting analog audio components for unparalleled sonic performance. Innovative engineering combines the new Krell CAST circuitry with existing Krell Current Mode technology to create entire CAST systems that reproduce music with incredible range, tonality, and precision.

### The Voltage Signal Transmission and the Traditional Audio System

Traditionally, signal is transmitted in the voltage domain between two components. In an audio system, each component is a discrete entity with unique characteristics that act upon the musical signal independently. Each component is unaware of the other components in the system. The cables that connect the components also have their own electrical characteristics, which affect the sonic presentation of the entire system. CAST transmission unifies individual components and interconnects into an electrically-linked whole. The original signal remains unaltered from source to speaker.

### CAST Basics

Here is how a CAST audio system works. Internally, each CAST source transfers, or amplifies, current using Krell Current Mode circuitry. This current signal is then output using CAST circuitry. When the signal is received by a CAST input, Krell Current Mode circuitry again takes over until the signal reaches the loudspeaker. By maintaining the musical signal in the current domain from beginning to end, an entire CAST system behaves as if it is one component. With CAST, circuit board properties and signal transmission aberrations between components are eliminated. Cable impedances and their effects on the transmitted signal are non-existent.

### How CAST and Krell Current Mode Interact

While CAST is a new method of transferring the musical signal between components, its origin stems from Krell Current Mode, the technology developed to transfer the musical signal within a component. CAST combined with Krell Current Mode circuitry takes signal transmission to the next evolutionary level. In essence,

Krell Current Mode maintains the integrity of the signal within the component and CAST preserves the transmitted signal between components. Together, CAST and Krell Current Mode technologies unify separate Krell components into a *single global circuit*. Krell Current Mode technology enjoys bandwidth increases up to an order of magnitude greater than their voltage based counterparts. This dramatic increase in circuit bandwidth delivers near perfection in the audible band that typically suffers from phase distortions in voltage circuits.

### **CAST Cable Construction**

A CAST system uses cables manufactured by Krell and other manufacturers specially licensed by Krell. Thin and flexible CAST cables are constructed with the same build quality as other Krell components and are aesthetically matched to the components that Krell manufactures. An all-metal body and locking connectors with gold contacts are part of the standard no-compromise specification developed for every CAST cable made.

### **Evolution CAST**

By employing revolutionary current mirror circuitry, the Evolution e Series amplifier components raises CAST technology to another level. This advanced use of the technology increases the linearity, transient speed, and bandwidth of the Evolution components while reducing the distortion by an order of magnitude.

### **The Best Musical Performance**

When you operate a CAST system, you will hear significant improvements in every performance area: speed, precision, dynamic range, depth and width of the sound stage, transient impact, tonal balance, harmonic distortion, and more. The goal for CAST is the same company goal used for all Krell products. Krell strives for the delivery of the best performance of a musical event for you, using the full expression of technology to date.



---

## Definition of Terms

The following are definitions of key terms used in this owner's reference:

### Inputs and Outputs

#### Balanced

A symmetrical input or output circuit that has equal impedance from both input terminals to a common ground reference point. The industry standard for professional and sound recording installations, balanced connections have 6 dB more gain than single-ended connections and allow the use of long interconnect cables. Balanced connections are completely immune to induced noise from the system or the environment.

#### CAST and Evolution CAST

Krell Current Audio Signal Transmission, or CAST, is a proprietary Krell circuit technology for connecting analog components, transmitting the audio waveform between components in the current domain rather than in the voltage domain. The speed and bandwidth provided by Krell CAST and its circuitry update, Evolution CAST, yield accurate, realistic music reproduction, enabling connected components to perform as if they are all part of a single circuit. CAST and Evolution CAST are balanced connections, and reject induced noise.

#### Single-ended

A two-wire input or output circuit. Single-ended connections are not recommended for connections requiring long cable runs. Use care when using single-ended connections, because the ground connection is made last and broken first. Turn the system off/on prior to making or breaking single-ended connections.

### Operation

#### Off

When the power status indicator is not illuminated, the amplifier is off.

#### Stand-by

A low-power-consumption status that keeps the audio and power supply circuits at idle. The power status indicator illuminates in green. Green is the default standby color and indicates an ultra low power draw of 2 watts. An optional red standby mode is available which keeps the input and driver stages continuously powered. Krell recommends leaving the amplifier in stand-by mode when it is not playing music.

#### Operation

When the power button is pressed, and the power status indicator is illuminated in blue, the amplifier is in operational mode and ready to play music.

## **Technology**

### **Active Cascode Topology**

A unique circuit technique that minimizes distortion by applying from 2 to 3 times more active devices to each gain stage thereby reducing the load on individual devices and improving circuit-wide linearity.

### **Krell Current Mode**

A proprietary Krell circuit topology in which the audio gain stages of a component operate in the current domain rather than the voltage domain. This unique technology provides the component with exceptional speed, and a wide bandwidth.

## SECTION **TWO**

---

### Unpacking and Placement

This section describes the procedures for safely unpacking and placing your Evolution e Series amplifier. The amplifier and accessories are shipped in 1 carton. The dimensions of the amplifier are shown in the specifications section starting on page 30.

Two people are needed to remove the Evolution e Series amplifier from its shipping box safely and easily.

### Opening the Evolution e Series Amplifier Shipping Carton

1. Open the shipping carton and remove the top layer of foam. The carton contains these items:
  - 1 Evolution e Series amplifier chassis
  - 1 20 amp AC power cord
  - 1 12 VDC (12 V trigger) cable
  - 1 Packet containing the Quick Setup Guide and the warranty registration card
2. Orient the shipping box so that one person stands at the front of the amplifier and one person stands at the back of the amplifier. Both people need to grab a pair of the cardboard handle cutouts (one pair located at the front of the amplifier and one pair located at the back of the amplifier) and simultaneously lift the amplifier straight up, out of the carton. Bend and lift with your knees, not your back.
3. Place the amplifier in a safe location, and remove the protective plastic wrapping.

**Note**

*Save all packing materials. If you need to ship the Evolution e Series amplifier in future, repack the unit in its original packaging to prevent shipping damage.*

## Placement

Before you install an Evolution e Series amplifier into your system, please follow the guidelines in this section to select a location for your component. This will facilitate a clean, trouble-free installation.

Place the amplifier on a firm, level surface, away from excessive heat, humidity, or moisture. The ventilation slots on the top of all Evolution e Series amplifiers and the ventilation slots on the back of the Evolution 302e and 400e amplifiers must be unobstructed at all time during operation. Do not place flammable material on top or beneath the component.

If you place the amplifier in a closed cabinet, you may need to modify shelf spacing or use small fans to increase ventilation. When the front and back of a cabinet are open, the air space between the chassis and shelf must be unobstructed.

Place the amplifier(s) as close to the loudspeakers as possible. While Evolution CAST and balanced technology permits long interconnect cable lengths, keep loudspeaker cable lengths to a minimum.

### AC Power Guidelines

The Evolution e Series amplifier requires a dedicated AC circuit rated at a minimum of 20 amps. Do not use extension cords, multiple AC adapters, or AC power strips.

#### **Note**

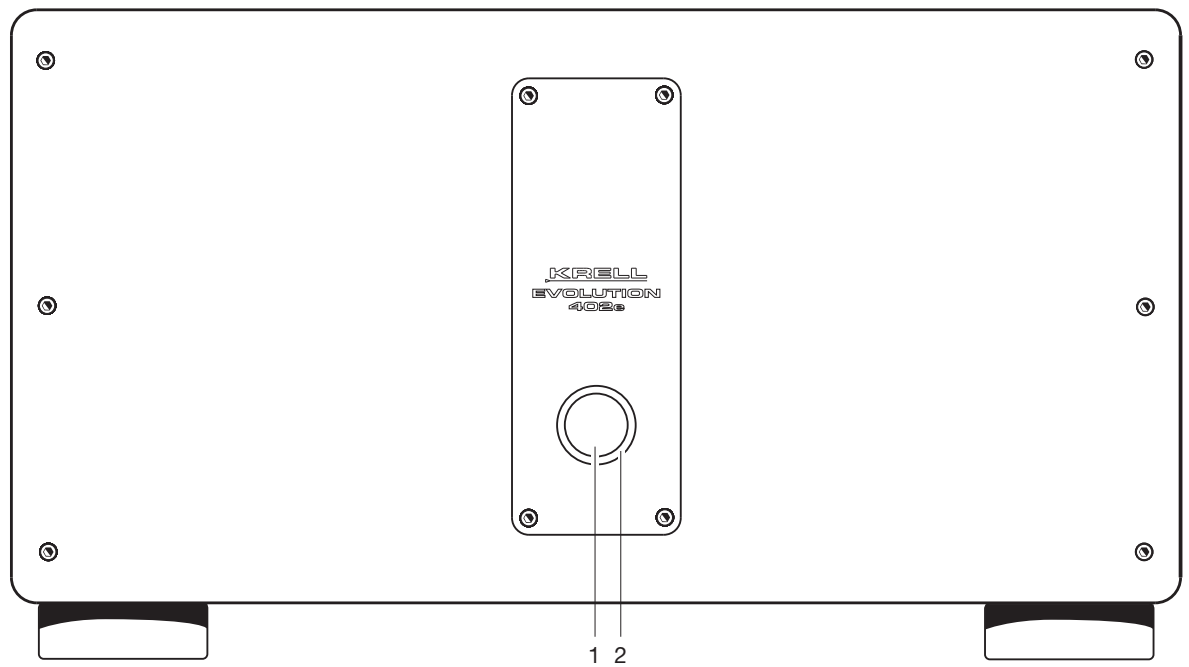
*Do not operate the Evolution e Series amplifiers with any device designed to alter or condition AC power.*

# SECTION **THREE**

## Anatomy of an Evolution e Series Amplifier

This section describes Evolution e Series amplifier functions.

**Figure 1** Evolution e Series Amplifier Front Panel (*Evolution 402e shown*)



- Power**
- 1 Power Button
  - 2 Power Status Indicator

## Front Panel Description

See Figure 1 on the previous page

Evolution e Series amplifier front panel functions are described below:

### Power

#### 1 Power Button

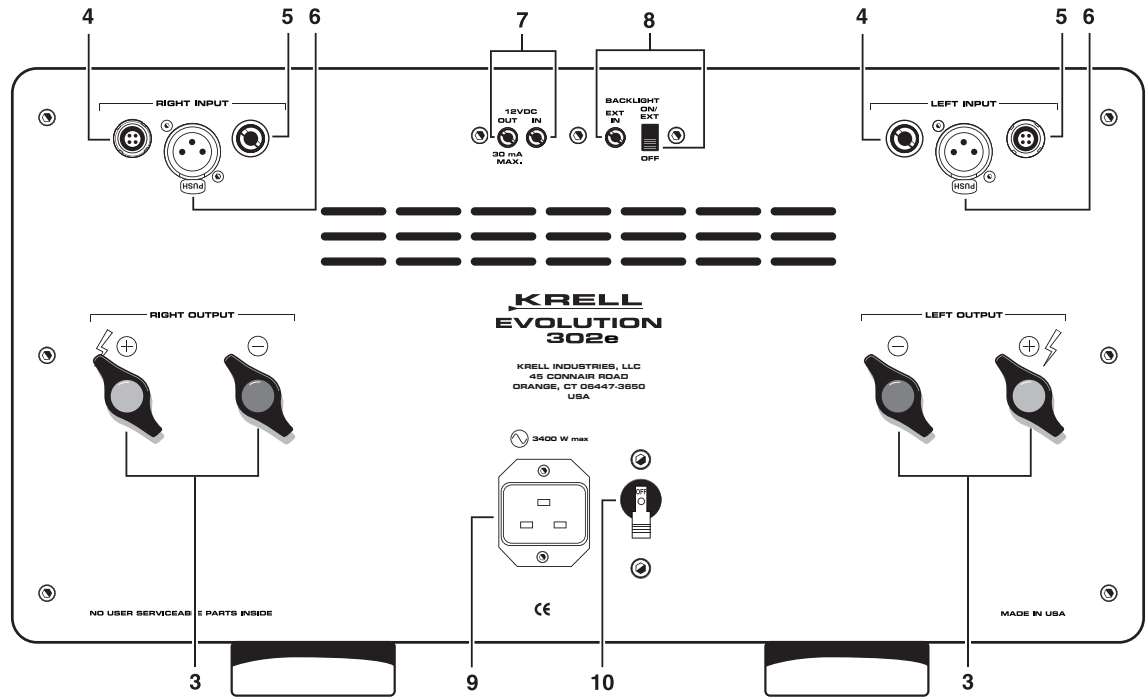
Press this button to place the Evolution e Series amplifier in operational mode.

#### 2 Power Status Indicator

The power status indicator is illuminated in either green or red when the amplifier is in stand-by mode. The indicator illuminates in blue when the amplifier is in operational mode. If there is no illumination, please check the following items:

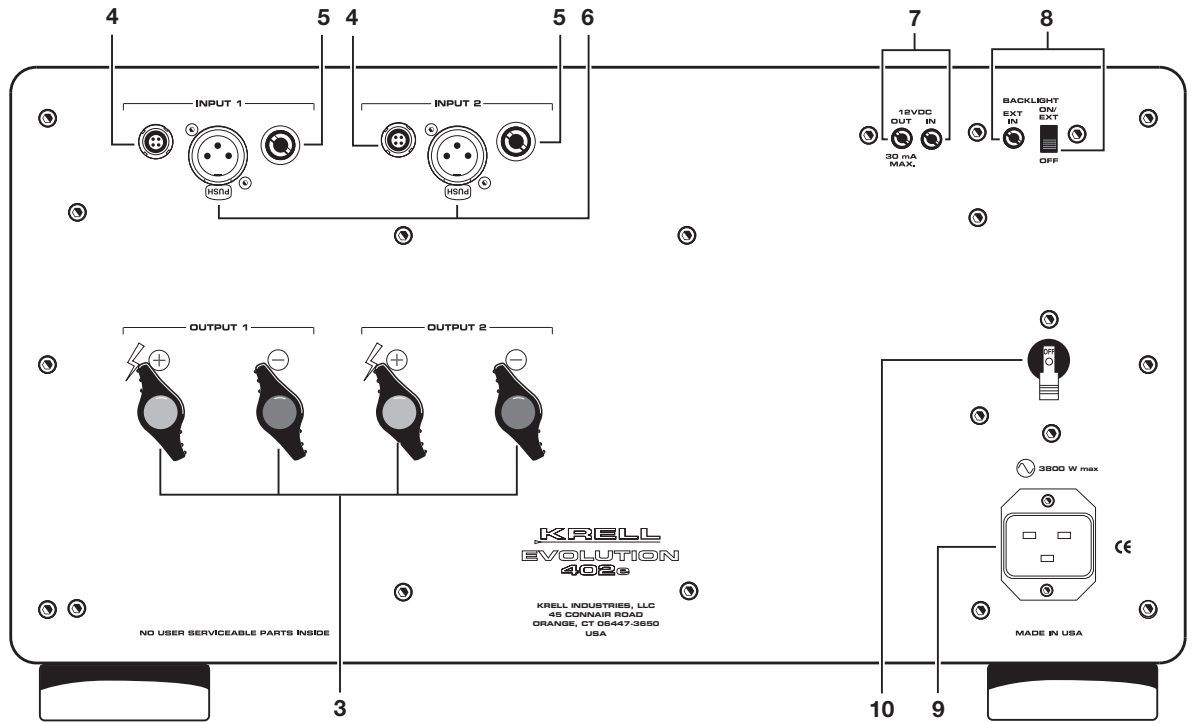
- The power cord is connected to the amplifier
- The power cord is plugged into a live AC power supply
- The back panel power breaker switch (10) is set to the on position
- The back panel backlight switch (8) is set to the on/ext position
- There is no 12 VDC controller connected to the EXT IN connector

**Figure 2** Evolution 302e Stereo Amplifier Back Panel



- |                |                                |
|----------------|--------------------------------|
| <b>Outputs</b> | 3 Loudspeaker Binding Posts    |
| <b>Inputs</b>  | 4 Single-ended Inputs          |
|                | 5 CAST Inputs                  |
|                | 6 Balanced Inputs              |
| <b>Remote</b>  | 7 12 VDC Out/In (12 V Trigger) |
|                | 8 Backlight Control            |
| <b>Power</b>   | 9 IEC Power Cord Receptacle    |
|                | 10 Power Breaker Switch        |

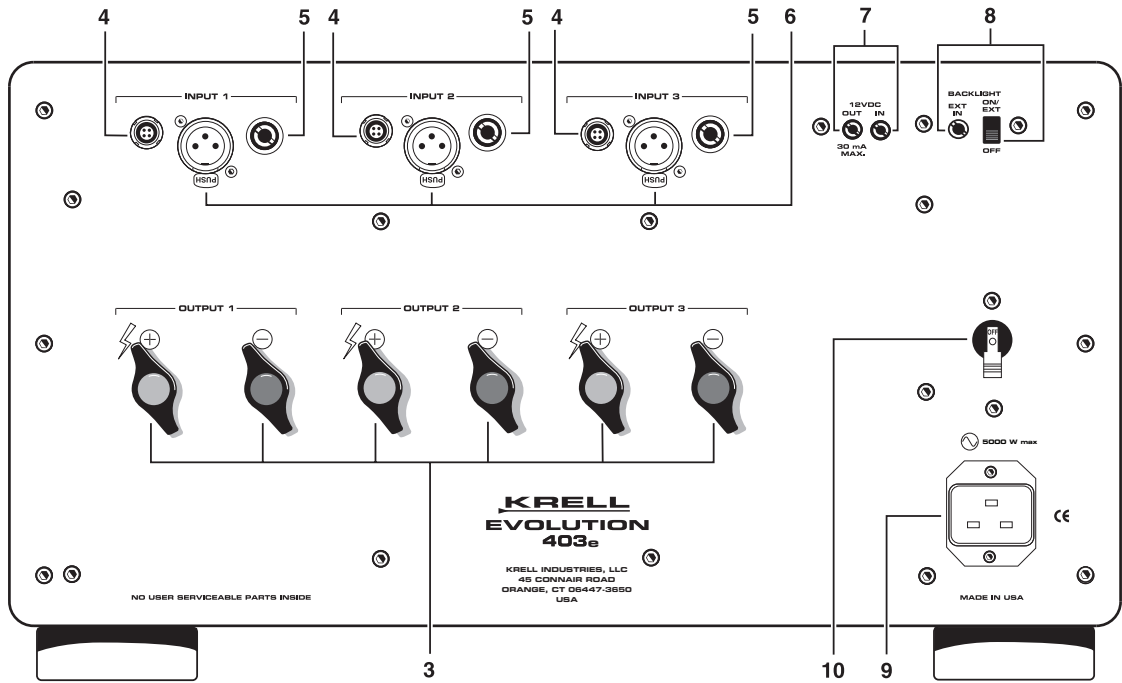
**Figure 3** Evolution 402e Stereo Amplifier Back Panel



- |                |                                |
|----------------|--------------------------------|
| <b>Outputs</b> | 3 Loudspeaker Binding Posts    |
| <b>Inputs</b>  | 4 CAST Inputs                  |
|                | 5 Single-ended Inputs          |
|                | 6 Balanced Inputs              |
| <b>Remote</b>  | 7 12 VDC Out/In (12 V Trigger) |
|                | 8 Backlight Control            |
| <b>Power</b>   | 9 IEC Power Cord Receptacle    |
|                | 10 Power Breaker Switch        |

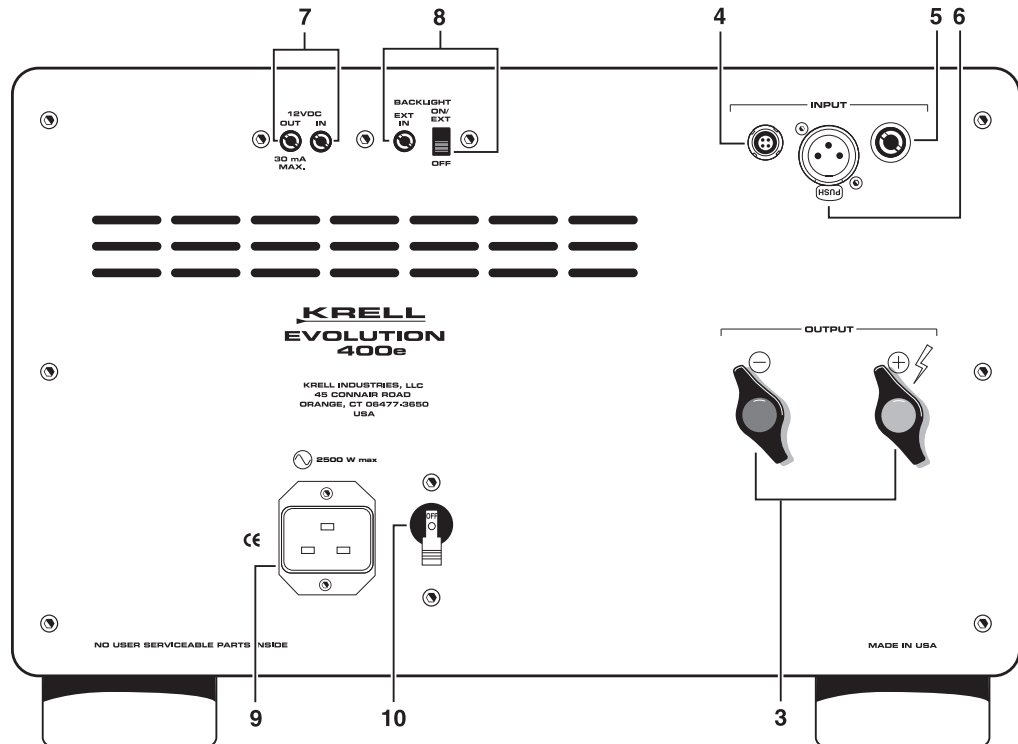


**Figure 4** Evolution 403e Multi-channel Amplifier Back Panel



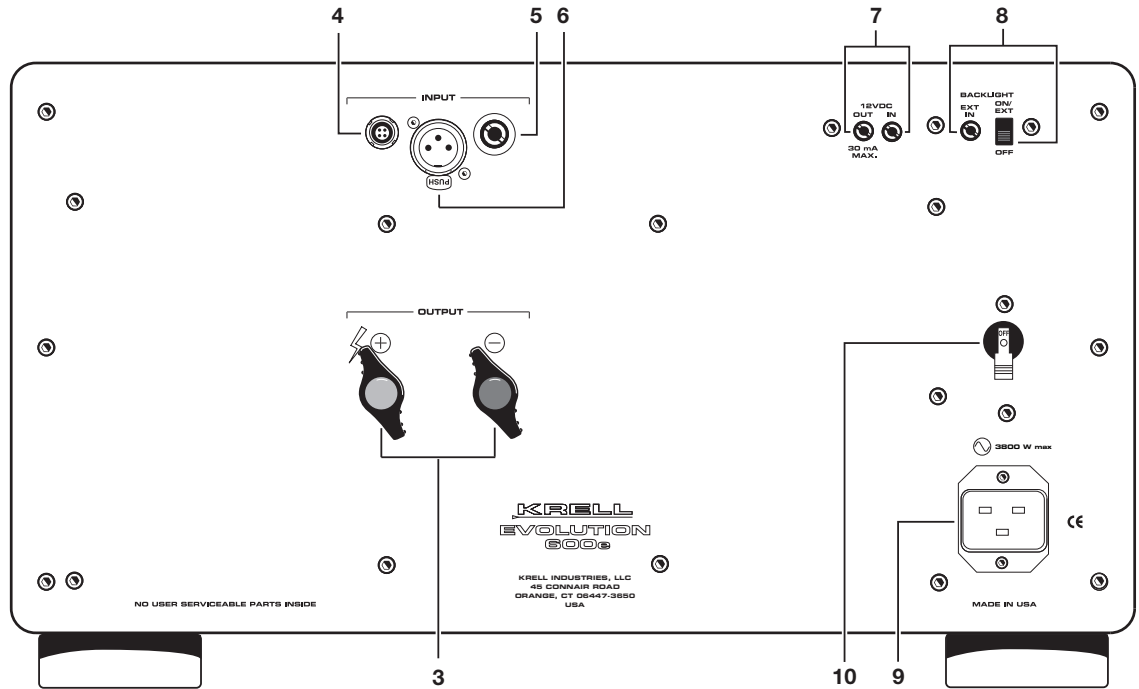
- |                |                                |
|----------------|--------------------------------|
| <b>Outputs</b> | 3 Loudspeaker Binding Posts    |
| <b>Inputs</b>  | 4 CAST Inputs                  |
|                | 5 Single-ended Inputs          |
|                | 6 Balanced Inputs              |
| <b>Remote</b>  | 7 12 VDC Out/In (12 V Trigger) |
|                | 8 Backlight Control            |
| <b>Power</b>   | 9 IEC Power Cord Receptacle    |
|                | 10 Power Breaker Switch        |

**Figure 5** Evolution 400e Monaural Amplifier Back Panel



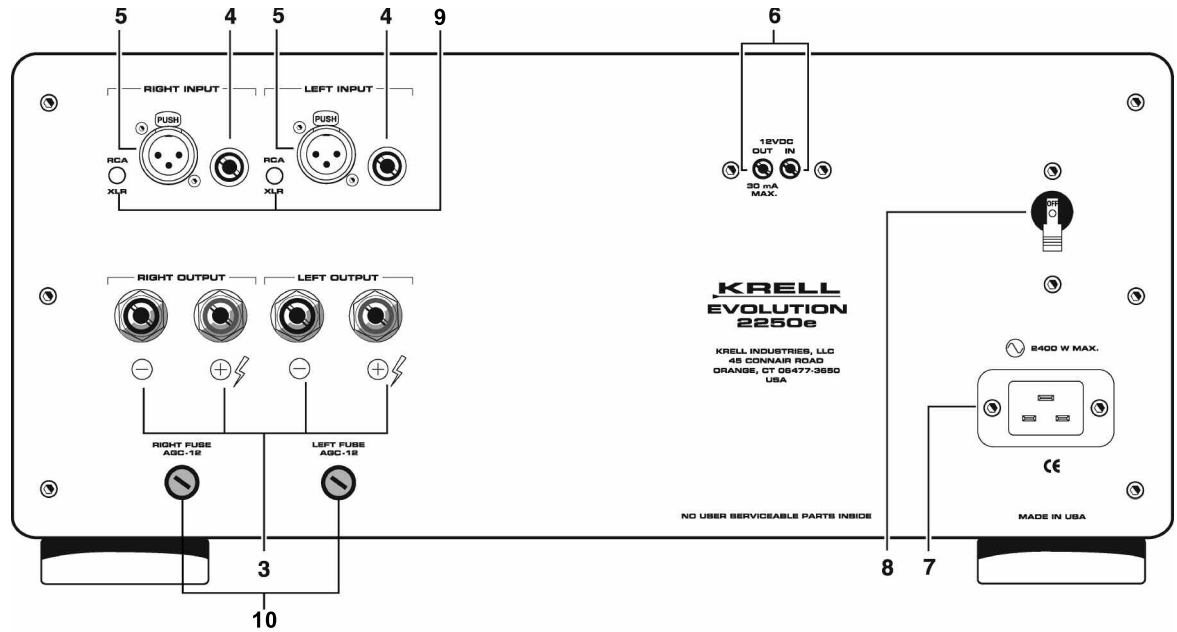
- |                |                                |
|----------------|--------------------------------|
| <b>Outputs</b> | 3 Loudspeaker Binding Posts    |
| <b>Inputs</b>  | 4 CAST Input                   |
|                | 5 Single-ended Input           |
|                | 6 Balanced Input               |
| <b>Remote</b>  | 7 12 VDC Out/In (12 V Trigger) |
|                | 8 Backlight Control            |
| <b>Power</b>   | 9 IEC Power Cord Receptacle    |
|                | 10 Power Breaker Switch        |

**Figure 5** Evolution e Series Monaural Amplifier Back Panel (Evolution 600e shown)



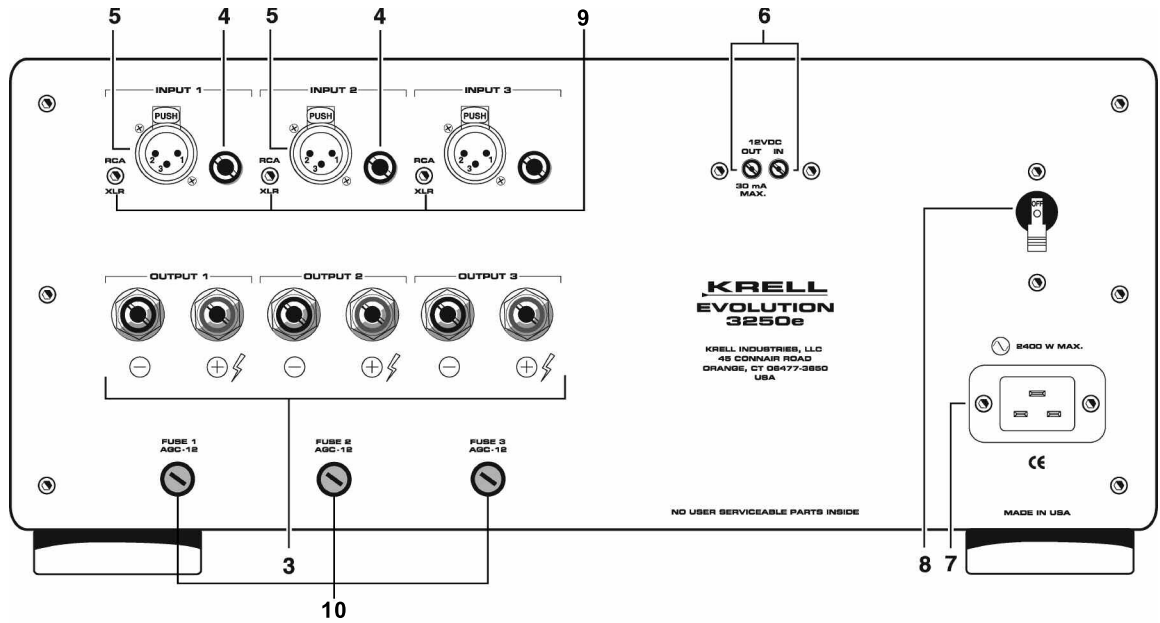
- |                |                                |
|----------------|--------------------------------|
| <b>Outputs</b> | 3 Loudspeaker Binding Posts    |
| <b>Inputs</b>  | 4 CAST Input                   |
|                | 5 Single-ended Input           |
|                | 6 Balanced Input               |
| <b>Remote</b>  | 7 12 VDC Out/In (12 V Trigger) |
|                | 8 Backlight Control            |
| <b>Power</b>   | 9 IEC Power Cord Receptacle    |
|                | 10 Power Breaker Switch        |

**Figure 6** Evolution e Series Stereo Amplifier Back Panel (*Evolution 2250e* shown)



- |         |                                    |
|---------|------------------------------------|
| Outputs | 3 Loudspeaker Binding Posts        |
| Inputs  | 4 Single-ended Input               |
|         | 5 Balanced Input                   |
|         | 9 XLR/Single-ended Selector Switch |
| Remote  | 6 12 VDC Out/In (12 V Trigger)     |
| Power   | 7 IEC Power Cord Receptacle        |
|         | 8 Power Breaker Switch             |
|         | 10 Speaker Fuses                   |

**Figure 7** Evolution e Series Three Channel Amplifier Back Panel (Evolution 3250e shown)



- |              |                                    |
|--------------|------------------------------------|
| Outputs      | 3 Loudspeaker Binding Posts        |
| Inputs       | 4 Single-ended Input               |
|              | 5 Balanced Input                   |
| Remote Power | 9 XLR/Single-ended Selector Switch |
|              | 6 12 VDC Out/In (12 V Trigger)     |
|              | 7 IEC Power Cord Receptacle        |
|              | 8 Power Breaker Switch             |
|              | 10 Speaker Fuses                   |

## Back Panel Description

See Figure 2, 3, 4 and 5 on the previous pages

The amplifier back panel provides access to the input and output connections, 12 V trigger inputs and outputs, and the AC power connection and switch. Back panel features and their descriptions follow:

### Outputs

#### 3 Loudspeaker Binding Posts (one pair per channel)

Each channel has one positive and one negative binding post. They accept spade lugs only.

### Inputs

#### 4 CAST Inputs (one per channel)

These are CAST inputs with 4-pin bayonet connectors, for use with Krell CAST-equipped preamplifiers and components.

#### 5 Single-ended Inputs (one per channel)

These are single-ended analog inputs with RCA connectors.

#### 6 Balanced Inputs (one per channel)

These are balanced analog inputs with XLR connectors.

### Remote Connections

#### 7 12 VDC In/Out (12 V Trigger)

**In.** The 12 V trigger allows you to turn the Evolution e Series amplifier on or to stand-by from other components.

**Out.** The output sends 12 VDC (12 V trigger) power on/off signals to other Krell components and other devices that incorporate a 12 V trigger, allowing whole systems or parts of systems to be easily controlled remotely. Mono 3.5 mm connectors are used in the following configuration: Tip = +12 V, Sleeve = GND.

#### Notes

*When an Evolution e Series amplifier is in the operational mode, the 12 V trigger provides 12 Volts of DC output. When the amplifier is in the stand-by mode or off, the DC output is 0 Volts. A maximum of 30 mA is available from the 12 V trigger output.*

*Consult the owner's reference of the components used in a custom installation to take full advantage of the remote capabilities of an Evolution e Series amplifier.*

## 8 Backlight Control

**Ext In.** Connect a 12 V trigger to the Ext In input connector to turn off the power status indicator (2) using a remote control. The switch must be set to On/Ext, in order for this to function (see below).

**On/Ext.** This activates the power status indicator. (This is the factory default position.)

**Off.** This turns off the power status indicator, during normal operation. The power status indicator remains illuminated for ten seconds after the power button is pressed.

## Power

### 9 IEC Power Cord Receptacle

The power receptacle is for use with the provided 20 amp AC power cord. Use only the power cord supplied with your Evolution e Series amplifier.

### 10 Power Breaker Switch

Place this switch in the up position to put the amplifier in stand-by mode. Place the switch in the down position to turn off the amplifier.

## Back Panel Description

See Figure 6 and 7 on the previous pages

The amplifier back panel provides access to the input and output connections, 12 V trigger inputs and outputs, and the AC power connection and switch. Back panel features and their descriptions follow:

### Outputs

#### 3 Loudspeaker Binding Posts (one pair per channel)

Each channel has one positive and one negative binding post. They accept spade lugs only.

### Inputs

#### 4 Single-ended Inputs (one per channel)

These are single-ended analog inputs with RCA connectors.

#### 5 Balanced Inputs (one per channel)

These are balanced analog inputs with XLR connectors.

#### 9 Input Switch

Set this switch for the style of connection being used, balanced/XLR or Single-ended/RCA.

### Remote Connections

#### 6 12 VDC In/Out (12 V Trigger)

**In.** The 12 V trigger allows you to turn the Evolution e Series amplifier on or to stand-by from other components.

**Out.** The output sends 12 VDC (12 V trigger) power on/off signals to other Krell components and other devices that incorporate a 12 V trigger, allowing whole systems or parts of systems to be easily controlled remotely. Mono 3.5 mm connectors are used in the following configuration: Tip = +12 V, Sleeve = GND.

#### Notes

*When an Evolution e Series amplifier is in the operational mode, the 12 V trigger provides 12 Volts of DC output. When the amplifier is in the stand-by mode or off, the DC output is 0 Volts. A maximum of 30 mA is available from the 12 V trigger output.*

*Consult the owner's reference of the components used in a custom installation to take full advantage of the remote capabilities of an Evolution e Series amplifier.*



## Power

### **7 IEC Power Cord Receptacle**

The power receptacle is for use with the provided 20 amp AC power cord. Use only the power cord supplied with your Evolution e Series amplifier.

### **8 Power Breaker Switch**

Place this switch in the up position to put the amplifier in stand-by mode. Place the switch in the down position to turn off the amplifier.

### **10 Speaker Fuses**

The speaker fuse protects the 2250e and 3250e in case of overload or malfunction.

## SECTION **FOUR**

---

### **Connecting an Evolution e Series Amplifier to Your System**

This section describes Evolution e Series amplifier connections. Each Evolution e Series 302e, 402e, 403e, 400e, 600e, and 900e amplifier channel has a CAST 4-pin connector, a balanced input via an XLR connector, a single-ended RCA connector, and a pair of loudspeaker binding posts. The rear panel also has 12 VDC trigger input and outputs, and a backlight remote trigger input. The Evolution e Series 2250e, and 3250e amplifier channel has a balanced input via an XLR connector, a single-ended RCA connector, and a pair of loudspeaker binding posts. The rear panel also has 12 VDC trigger input and output. All inputs and outputs are located on the Evolution e Series amplifier back panel. Maintain the correct left/right orientation, when hooking up your system.

#### **CAST Connections**

Krell recommends using its proprietary Krell CAST system for unparalleled sonic performance for connections between the Evolution e Series amplifier and other CAST-equipped components. Krell CAST uses flexible interconnecting cables that can be drawn through tight spaces and concealed.

#### **Balanced Connections**

The Evolution e Series amplifier also offers balanced operation. The circuitry and connections associated with balanced operation not only can minimize sonic loss but also are immune to induced noise, especially for installations using long cables.

##### **XLR Pin Configuration**

Pin 1	Ground
Pin 2	Non-inverting (0°) (hot)
Pin 3	Inverting (180°) (cold)

#### **Single-ended Connections**

Each Evolution e Series amplifier channel has one single-ended input. If connecting a vacuum tube preamplifier, use the single-ended inputs only (see below). Connect the u-shaped jumpers between pins 1 and 3 of the XLR connectors when using single-ended inputs. On the 2250e and 3250e use the Input Select Switch to select single-ended. No jumpers are necessary.

## Evolution DC Protection Circuitry/Using Tube Preamplifiers

The high DC output of tube preamplifiers may exceed the active DC protection circuitry of the Evolution e Series amplifiers. Excessive DC level in a signal can damage amplifiers, loudspeakers, or both. The single-ended inputs of the Evolution e Series amplifiers are capacitor-coupled and DC does not pass through. Therefore, if connecting a tube preamplifier, use the single-ended inputs only. For more information about DC protection circuitry features, see **Error Codes** on page 31.

## Connection Steps

### See Figure 8 on Page 28

Position the amplifier where you intend to use it in your system.

The following steps describe how to connect an Evolution e Series amplifier to your system:

1. Turn off all power sources and components before connecting inputs and outputs.
2. Neatly arrange and organize wiring to and from the Evolution e Series amplifier and all components. Separate AC wires from audio cables to prevent hum or other unwanted noise from being introduced into the system.
3. Connect the outputs of your preamplifier to the appropriate CAST (4), balanced (6), or single-ended inputs (5) on the Evolution e Series amplifier.

#### **Note**

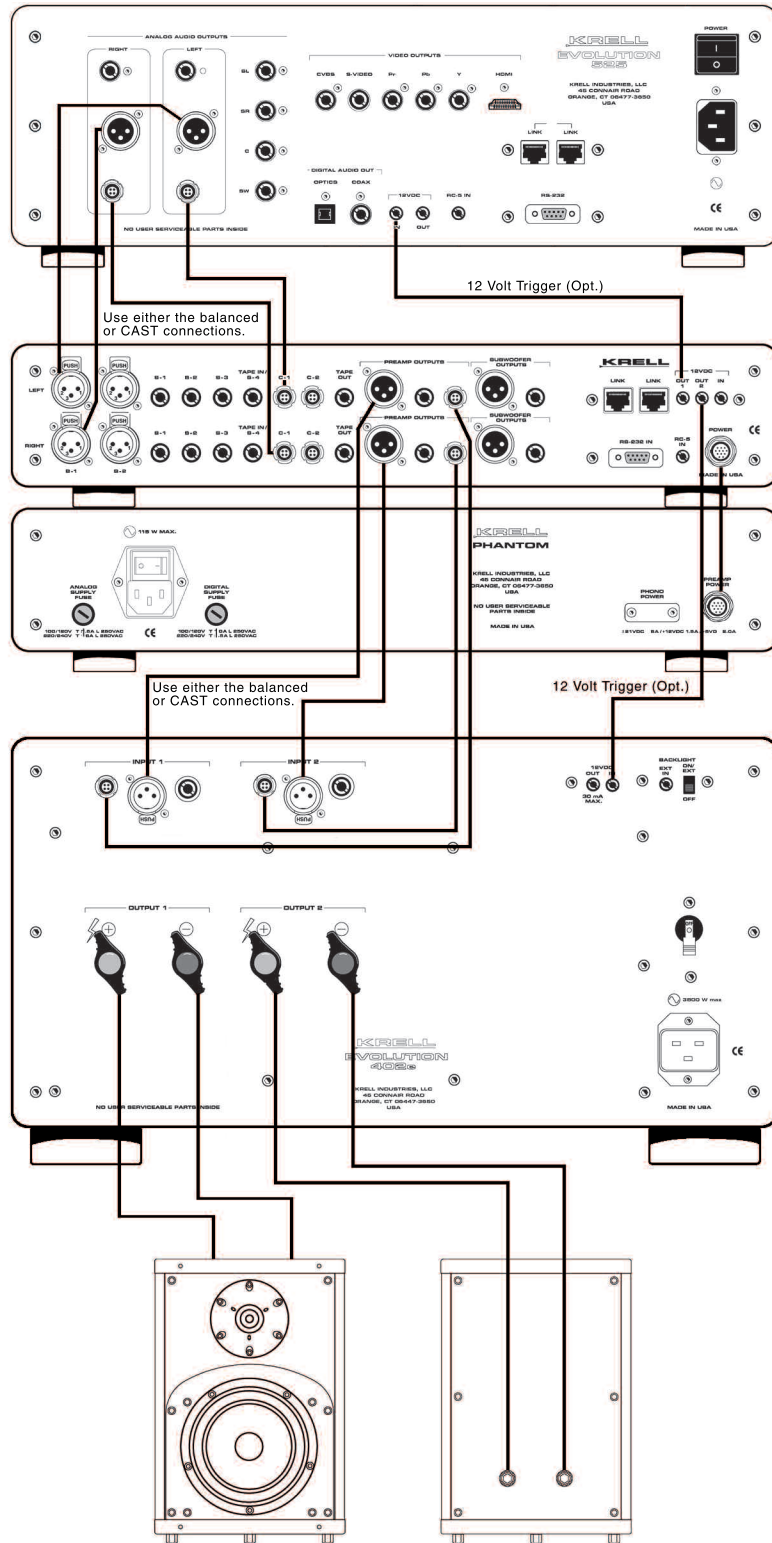
*Connect the u-shaped jumpers between pins 1 and 3 of the XLR connectors when using single-ended inputs. On 2250e and 3250e toggle the Input Select Switch to single-ended.*

4. Connect the loudspeaker cables to the loudspeaker binding posts (7) on the Evolution e Series amplifier. The binding posts accept spade lugs only. Take care to observe the correct polarity when making connections: The positive (+) output connects to the positive input of the loudspeaker. The negative (-) output connects to the negative input of the loudspeaker.
5. Connect the supplied AC power cord to the AC power cord receptacle (9).
6. Plug the AC power cord into AC power.

#### **Note**

*Use only the power cord provided with the Evolution e Series amplifier to make the connection to AC power. Operation with a power cord other than the one supplied by Krell could induce noise, limit current, or otherwise impair the ability of the amplifier to perform optimally.*

**Figure 8** Connection Diagram



## SECTION **FIVE**

---

### Evolution e Series Amplifier Operation

The Evolution e Series amplifiers are easy to operate.

**IMPORTANT**

*When powering up any system, turn the amplifier on last. When powering down, turn it off first. This will prevent any turn-on and turn-off thumps in your loudspeakers.*

*Always mute or fully attenuate the preamplifier level when switching sources. Do not change input connections to the amplifier when the amplifier is on.*

*Krell amplifiers have large reserves of clean power that can safely drive loudspeakers to higher sound pressure levels than other amplifiers. Use care when setting high playback levels, and lower the volume level at the first sign of loudspeaker distress.*

#### On/Off and Stand-by Operation

1. Move the back panel power breaker switch (10) to the up position to place the amplifier in stand-by mode. The power status indicator (2) illuminates in green. Green is the default standby color and indicates an ultra low power draw of 2 watts. On the Evolution 302e, 402e, 403e, 400e, 600e, and 900e amplifiers an optional red standby mode is available which keeps the input and driver stages continuously powered. To engage the red standby power mode, move the power breaker switch (10) to the down position, and while pressing the power button (1) on the amplifier front panel, return power breaker switch (10) to the up position. Repeat the procedure to return to the green operating mode.
2. Press the power button (1) on the amplifier front panel. The power status indicator (2) illuminates in blue.

The initial power-up phase lasts approximately 30 seconds from the moment the back panel power breaker switch is placed in the up position. If the power button is pressed during this period, the power status indicator flashes blue for the remainder of the initial power-up phase. When the initial power-up phase is complete, the power indicator illuminates in blue and is no longer flashing. The amplifier is in the operational mode.

3. With the preamplifier muted or its volume completely lowered, select a source.
4. Increase the volume control to the desired listening level.
5. To return the amplifier to stand-by, press the power button on the front panel. The power status indicator turns green or red, and the amplifier is in the stand-by mode.

It is now safe to place the rest of the system in stand-by.

#### Powering Off

Krell recommends leaving Evolution e Series amplifiers in the stand-by mode between listening sessions. Turn the amplifier off using the power breaker switch (10), and disconnect the amplifier from AC power when the system is not being used for an extended

## Troubleshooting System Noise

AC grounding becomes critical when connecting high-performance audio components. When you mix and match high-performance audio components, each with its own ground potential, a low frequency hum may occur in one or both loudspeakers. This often occurs when introducing a new component into a system.

If this happens when you place the Evolution e Series amplifier into your system, follow these simple troubleshooting steps.

*Note*

*During these steps, the back panel power breaker switch remains in the on position.*

- 1.** Check that all input and output connections are of sound construction.
- 2.** With the amplifier in stand-by mode, remove the interconnect cables, then turn the amplifier on. If the hum disappears, turn the amplifier into stand-by mode again, and reinsert one of the interconnect cables. Turn the amplifier back on. Repeat this process for each cable.
- 3.** If the hum reappears with one or both interconnect cables reinserted, the cable needs to be checked.
- 4.** If the interconnect cables are sound, you may be experiencing a ground loop. Please contact your authorized Krell dealer, distributor, or Krell for suggestions on how to eliminate the ground loop.

## Error Codes

In the event of a problem, the power status indicator (2) will flash error code(s) in red. Errors are identified by a sequence flashes. There is a pause between codes, and in the case where there is only one error code, the same code is repeated.

<b>Diagnostic Code</b>	<b>Possible Condition</b>	<b>Course of Action</b>
1 flash	Internal power supply rail fault	Breaker Switch will automatically shut off. Contact your Dealer / Distributor or the Krell Factory.
2 flashes	Excessive DC at Output	Breaker Switch will automatically shut off. Contact your Dealer / Distributor or the Krell Factory.
3 flashes	Excessive Output Current	Check loudspeaker and cables for short circuits. If you are driving more than one loudspeaker per channel, check that the combined load does not drop below 2 Ohms. The power breaker switch must be shut off to reset the fault condition.
4 flashes	Excessive temperature	Allow the amplifier to cool, and increase ventilation. If the problem persists, please contact your Dealer / Distributor.
5 flashes	Excessive DC at input	Check the preamplifier output and source outputs for excessive DC voltage. If you are using a vacuum tube preamplifier, use only the single-ended inputs, as they are capacitor coupled.
6 flashes	Line frequency error	Contact your Dealer / Distributor or the Krell Factory.

# SECTION **SEVEN**

---

## Questions and Answers

- Q.** Should I leave my Evolution e Series amplifier on at all times?
- A.** For maximum amplifier performance, leave the back panel power breaker switch on at all times. This places the amplifier in stand-by mode. Evolution e Series amplifiers are designed to be powered on and off from stand-by, using the front panel power button.
- Q.** When I turn on the amplifier there is a loud hum through the loudspeakers. What should I do?
- A.** When a new component is introduced, a low frequency hum may occur in one or both loudspeakers. Check all input and output connections and cables, making sure they are of sound construction. See ***Troubleshooting System Noise***, on page 24. If the interconnects and cables are sound, you may be experiencing a ground loop. This can often be easily eliminated. Please contact your authorized Krell dealer, distributor, or Krell for suggestions on how to solve this problem.
- Q.** My loudspeakers are rated for 150 Watts. Are the Evolution models too powerful for them?
- A.** No. A loudspeaker seldom is damaged from overdriving. More often, damage occurs when an amplifier that lacks sufficient power is asked to handle heavy demand situations such as high playback levels. These amplifiers may have very high 8 Ohm power ratings, but in heavy demand situations they can be driven into clipping (in which high power, high frequency harmonics go to the loudspeakers, due to loss of amplifier power). Clipping can damage loudspeakers. Avoid damage to your loudspeakers by reviewing your loudspeaker's specifications, and exercise caution in heavy demand situations.



---

## Warranty

Krell products have a limited warranty. Amplifiers, preamplifiers, preamp/processors, and receivers carry a limited warranty of five years from date of purchase or six years from date of manufacture for parts and labor on circuitry. Loudspeakers carry a limited warranty of five years from date of purchase or six years from date of manufacture for parts and labor. CD and DVD players carry a limited warranty of five years from date of purchase or six years from date of manufacture for parts and labor on circuitry, and three years for parts and labor on mechanical parts. Should the product fail to perform at any time during the warranty, Krell will repair it at no cost to the owner, except as set forth in this warranty. This warranty does not apply to damage caused by acts of God or nature. This warranty shall be in lieu of any other warranty, expressed or implied, including, but not limited to, any implied warranty of merchantability or fitness for a particular purpose. There are no warranties which exceed beyond those described in this document, if the product does not perform as warranted herein, the owner's sole remedy shall be repair. In no event will Krell be liable for incidental or consequential damages arising from purchase, use, or inability to use the product, even if Krell has been advised of the possibility of such damages.

### **IMPORTANT**

***The single-ended inputs on the Evolution e Series amplifiers are capacitor-coupled. Use these inputs whenever you are connecting a tube preamplifier.***

Proof of purchase in the form of a bill of sale or receipted invoice substantiating that the product is within the warranty period must be presented to obtain warranty service. The warranty begins on the date of the original retail purchase, as noted on the bill of sale or receipted invoice from an authorized Krell dealer or distributor. Previously owned equipment, when re-purchased from an authorized Krell dealer or distributor, has the balance of the original warranty, based on the original date of manufacture. Krell dealers and distributors are not authorized to sell current products on the Internet. Current products purchased via the Internet do not have any transferrable warranty.

The warranty for a Krell product is valid only in the country to which it was originally shipped, through the authorized Krell distributor for that country, and at the factory. There may be restrictions on or changes to the Krell warranty because of regulations within a specific country. Please check with your distributor for a complete understanding of the warranty in your country.

---

If the product is serviced by a distributor who did not import the unit, there may be a charge for service, even if the product is within the warranty period.

Freight to the factory is your responsibility. Return freight within the United States (U.S.A.) is included in the warranty. If you have purchased your Krell product outside the U.S.A. and wish to have it serviced at the factory, all freight and associated charges to the factory are your responsibility. Krell will pay return freight to the U.S.A.-based freight forwarder of your choice. Freight and other charges to ship the product from the freight forwarder to you are also your responsibility.

Krell is not responsible for any damage incurred in transit. Krell will file claims for damages as necessary for a product damaged in transit to the factory. You are responsible for filing claims for shipping damages during the return shipment.

Krell does not supply replacement parts and/or products to the owner of the product. Replacement parts and/or products will be furnished only to the distributor performing service on this product on an exchange basis only; any parts and/or products returned to Krell for exchange become the property of Krell.

No expressed or implied warranty is made for any Krell product damaged by accident, abuse, misuse, natural or personal disaster, or unauthorized modification.

***Any unauthorized voltage conversion, disassembly, component replacement, perforation of chassis, updates, or modifications performed to the product will void the warranty.***

The operating voltage of the product is determined by the factory and can only be changed by an authorized Krell distributor or at the factory. The voltage for this product in the U.S.A. cannot be changed until six months from the original purchase date.

In the event that Krell receives a product for warranty service that has been modified in any way without Krell authorization, all warranties on that product will be void. The product will be returned to original factory layout specifications at the owner's expense before it is repaired. All repairs required after the product has been returned to original factory specifications will be charged to the customer, at current parts and labor rates.

All operational features, functions, and specifications and policies are subject to change without notification.

***To register your product for warranty benefits, please complete and return the Warranty Registration Card enclosed in the shipping box within 15 days of purchase. Thank you.***

---

## Return Authorization Procedure

### How to Expedite Service

If you believe there is a problem with your component, please contact your dealer, distributor, or the Krell factory to discuss the problem *before* you return the component for repair. To expedite service, you may wish to complete and e-mail the Service Request Form in the Service section of our website at:

<http://www.krellonline.com>

### To contact the Krell Service Department:

TELL 203-298-4020, Monday-Friday  
9:00 AM to 5:00 PM EST

FAX 203-795-2287

E-MAIL [service@krellonline.com](mailto:service@krellonline.com)

WEBSITE <http://www.krellonline.com>

### How to Return a Product

To return a product to Krell, please follow this procedure so that we may serve you better:

1. Obtain a Return Authorization Number (R/A number) and shipping address from the Krell Service Department.
2. Insure and accept all liability for loss or damage to the product during shipment to the Krell factory and ensure that all freight (shipping) charges are prepaid.

The product may also be hand delivered if arrangements with the Service Department have been made in advance. Proof of purchase will be required for warranty validation at the time of hand delivery.

### **IMPORTANT**

*Use the original packaging to ensure the safe transit of the product to the factory, dealer, or distributor. Krell may, at its discretion, return a product in new packaging and bill the owner for such packaging if the product received by Krell was boxed in nonstandard packaging or if the original packaging was so damaged that it was unusable. If Krell determines that new packaging is required, the owner will be notified before the product is returned.*

### How to Purchase Additional Packing

To purchase additional packing, please contact your authorized Krell dealer, distributor, or the Krell Service Department for assistance.

# Specifications

Measurement	Evolution 302e Amplifier	Evolution 402e Amplifier
<b>FREQUENCY RESPONSE</b>	20 Hz to 20 kHz +0, -0.10 dB <0.5 Hz to 180 kHz +0, -3 dB	20 Hz to 20 kHz +0, -0.18 dB <0.5 Hz to 120 kHz +0, -3 dB
<b>SIGNAL-TO-NOISE RATIO</b>		
Wideband, unweighted, referred to full power output	>107 dB	>106 dB
“A” weighted	>117 dB	>116 dB
<b>GAIN</b>	25.5 dB	25.4 dB
<b>TOTAL HARMONIC DISTORTION</b>	<0.02% at 1 kHz, at 300 W, 8 Ohms <0.15% at 20 kHz, at 300 W, 8 Ohms	<0.02% at 1 kHz, at 400 W, 8 Ohms <0.15% at 20 kHz, at 400 W, 8 Ohms
<b>INPUT IMPEDANCE</b>		
Single-ended	100 kOhms	100 kOhms
Balanced	200 kOhms	200 kOhms
CAST	75 Ohms	70 Ohms
<b>INPUT SENSITIVITY</b>		
Single-ended or balanced	2.60 V rms	3.04 V rms
CAST	2.60 mA rms	3.04 mA rms
<b>OUTPUT POWER</b>		
All channels driven	300 W rms at 8 Ohms 600 W rms at 4 Ohms 1200 W rms at 2 Ohms	400 W rms at 8 Ohms 800 W rms at 4 Ohms 1600 W rms at 2 Ohms
<b>OUTPUT VOLTAGE</b>	139 V peak-to-peak 49 V rms	160 V peak-to-peak 57 V rms
<b>OUTPUT CURRENT</b>	35 A peak	37 A peak
<b>SLEW RATE</b>	120 V/ $\mu$ s	100 V/ $\mu$ s
<b>OUTPUT IMPEDANCE</b>	<0.040 Ohms at 20 Hz <0.053 Ohms, 20 Hz to 20 kHz	<0.055 Ohms at 20 Hz <0.064 Ohms, 20 Hz to 20 kHz
<b>DAMPING FACTOR</b>		
Referred to 8 Ohms	>200 at 20 Hz >150, 20 Hz to 20 kHz	>145 at 20 Hz >125, 20 Hz to 20 kHz
<b>POWER CONSUMPTION</b>		
Stand-by	2 W	2 W
High Current Stand-by	150 W	260 W
Idle	320 W	390 W
Maximum	3400 W	3800 W
<b>HEAT OUTPUT</b>		
Stand-by	7 BTU/hr.	7 BTU/hr.
High Current Stand-by	510 BTU/hr.	890 BTU/hr.
Idle	1100 BTU/hr.	1300 BTU/hr.
Maximum	5500 BTU/hr.	6400 BTU/hr.
<b>INPUTS</b>	2 single-ended via RCA connector 2 balanced via XLR connector 2 CAST via 4-pin bayonet connector	2 single-ended via RCA connector 2 balanced via XLR connector 2 CAST via 4-pin bayonet connector
<b>OUTPUTS</b>	2 pairs Krell binding posts	2 pairs Krell binding posts
<b>DIMENSIONS</b>	17.3 in. W x 9.8 in. H x 20.7 in. D 438 mm W x 248 mm H x 525 mm D	17.3 in. W x 9.8 in. H x 22.1 in. D 438 mm W x 248 mm H x 550 mm D
<b>WEIGHT</b>		
Shipping	138 lb., 62.4 kg	150 lb., 67.9 kg
Unit only	120 lb., 54.3 kg	135 lb., 61.1 kg

All operational features, functions, specifications, and policies are subject to change without notification.

(Specifications continued)

Measurement	Evolution 403e Amplifier	Evolution 400e Monaural Amplifier
<b>FREQUENCY RESPONSE</b>	20 Hz to 20 kHz +0, -0.18 dB <0.5 Hz to 120 kHz +0, -3 dB	20 Hz to 20 kHz +0, -0.18 dB <0.5 Hz to 125 kHz +0, -3 dB
<b>SIGNAL-TO-NOISE RATIO</b>		
Wideband, unweighted, referred to full power output	>106 dB	>108 dB
“A” weighted	>116 dB	>118 dB
<b>GAIN</b>	25.4 dB	25.4 dB
<b>TOTAL HARMONIC DISTORTION</b>	<0.02% at 1 kHz, at 400 W, 8 Ohms <0.15% at 20 kHz, at 400 W, 8 Ohms	<0.02% at 1 kHz, at 400 W, 8 Ohms <0.15% at 20 kHz, at 400 W, 8 Ohms
<b>INPUT IMPEDANCE</b>		
Single-ended	100 kOhms	100 kOhms
Balanced	200 kOhms	200 kOhms
CAST	70 Ohms	70 Ohms
<b>INPUT SENSITIVITY</b>		
Single-ended or balanced	3.04 V rms	3.04 V rms
CAST	3.04 mA rms	3.04 mA rms
<b>OUTPUT POWER</b>	400 W rms at 8 Ohms 800 W rms at 4 Ohms 1600 W rms at 2 Ohms	400 W rms at 8 Ohms 800 W rms at 4 Ohms 1600 W rms at 2 Ohms
<b>OUTPUT VOLTAGE</b>	160 V peak-to-peak 57 V rms	160 V peak-to-peak 57 V rms
<b>OUTPUT CURRENT</b>	37 A peak	37 A peak
<b>SLEW RATE</b>	100 V/ $\mu$ s	100 V/ $\mu$ s
<b>OUTPUT IMPEDANCE</b>	<0.055 Ohms at 20 Hz <0.064 Ohms, 20 Hz to 20 kHz	<0.055 Ohms at 20 Hz <0.064 Ohms, 20 Hz to 20 kHz
<b>DAMPING FACTOR</b>	>145 at 20 Hz Referred to 8 Ohms >125, 20 Hz to 20 kHz	>145 at 20 Hz >125, 20 Hz to 20 kHz
<b>POWER CONSUMPTION</b>		
Stand-by	2 W	2 W
High Current Stand-by	370 W	150 W
Idle	570 W	210 W
Maximum	5000 W	2500 W
<b>HEAT OUTPUT</b>		
Stand-by	7 BTU/hr	7 BTU/hr.
High Current Stand-by	1270 BTU/hr.	510 BTU/hr.
Idle	1950 BTU/hr.	720 BTU/hr.
Maximum	7700 BTU/hr.	3800 BTU/hr.
<b>INPUTS</b>	3 single-ended via RCA connector 3 balanced via XLR connector 3 CAST via 4-pin bayonet connector	1 single-ended via RCA connector 1 balanced via XLR connector 1 CAST via 4-pin bayonet connector
<b>OUTPUTS</b>	3 pairs Krell binding posts	3 pairs Krell binding posts
<b>DIMENSIONS</b>	17.3 in. W x 9.8 in. H x 26.1 in. D 438 mm W x 248 mm H x 662 mm D	14.5 in. W x 9.8 in. H x 20.65 in. D 368 mm W x 248 mm H x 525 mm D
<b>WEIGHT</b>		
Shipping	190 lb., 86 kg	120 lb., 54.3 kg
Unit only	175 lb., 79.2 kg	102 lb., 46.2 kg

All operational features, functions, specifications, and policies are subject to change without notification.

continued

(Specifications continued)

Measurement	Evolution 600e Monaural Amplifier	Evolution 900e Monaural Amplifier
<b>FREQUENCY RESPONSE</b>	20 Hz to 20 kHz +0, -0.18 dB <0.5 Hz to 120 kHz +0, -3 dB	20 Hz to 20 kHz +0, -0.18 dB <0.5 Hz to 120 kHz +0, -3 dB
<b>SIGNAL-TO-NOISE RATIO</b>		
Wideband, unweighted, referred to full power output	>110 dB	>113 dB
“A” weighted	>119 dB	>122 dB
<b>GAIN</b>	25.4 dB	25.4 dB
<b>TOTAL HARMONIC DISTORTION</b>	<0.02% at 1 kHz, at 600 W, 8 Ohms <0.15% at 20 kHz, at 600 W, 8 Ohms	<0.02% at 1 kHz, at 900 W, 8 Ohms <0.15% at 20 kHz, at 900 W, 8 Ohms
<b>INPUT IMPEDANCE</b>		
Single-ended	100 kOhms	100 kOhms
Balanced	200 kOhms	200 kOhms
CAST	70 Ohms	70 Ohms
<b>INPUT SENSITIVITY</b>		
Single-ended or balanced	3.72 V rms	4.55 V rms
CAST	3.72 mA rms	4.55 mA rms
<b>OUTPUT POWER</b>	600 W rms at 8 Ohms 1200 W rms at 4 Ohms 2400 W rms at 2 Ohms	900 W rms at 8 Ohms 1800 W rms at 4 Ohms 3600 W rms at 2 Ohms
<b>OUTPUT VOLTAGE</b>	196 V peak-to-peak 69 V rms	240 V peak-to-peak 85 V rms
<b>OUTPUT CURRENT</b>	49 A peak	60 A peak
<b>SLEW RATE</b>	100 V/ $\mu$ s	90 V/ $\mu$ s
<b>OUTPUT IMPEDANCE</b>	<0.030 Ohms, 20 Hz to 20 kHz	<0.023 Ohms, 20 Hz to 20 kHz
<b>DAMPING FACTOR</b> Referred to 8 Ohms	>270, 20 Hz to 20 kHz	>350, 20 Hz to 20 kHz
<b>POWER CONSUMPTION</b>		
Stand-by	2 W	2 W
High Current Stand-by	260 W	440 W
Idle	410 W	650 W
Maximum	3800 W	5000 W
<b>HEAT OUTPUT</b>		
Stand-by	7 BTU/hr.	7 BTU/hr.
High Current Stand-by	890 BTU/hr.	1500 BTU/hr.
Idle	1400 BTU/hr.	2200 BTU/hr.
Maximum	5500 BTU/hr.	7700 BTU/hr.
<b>INPUTS</b>	1 single-ended via RCA connector 1 balanced via XLR connector 1 CAST via 4-pin bayonet connector	1 single-ended via RCA connector 1 balanced via XLR connector 1 CAST via 4-pin bayonet connector
<b>OUTPUTS</b>	1 pair Krell binding posts	1 pair Krell binding posts
<b>DIMENSIONS</b>	17.3 in. W x 9.8 in. H x 22.1 in. D 438 mm W x 248 mm H x 560 mm D	17.3 in. W x 9.8 in. H x 26.1 in. D 438 mm W x 248 mm H x 662 mm D
<b>WEIGHT</b>		
Shipping	150 lb., 67.9 kg	190 lb., 86 kg
Unit only	135 lb., 61.1 kg	175 lb., 79.2 kg

All operational features, functions, specifications, and policies are subject to change without notification.

(Specifications continued)

Measurement	Evolution 2250e Amplifier	Evolution 3250e Amplifier
<b>FREQUENCY RESPONSE</b>	20 Hz to 20 kHz +0, -0.07 dB <0.3 Hz to 150 kHz +0, -3 dB	20 Hz to 20 kHz +0, -0.07 dB <0.3 Hz to 150 kHz +0, -3 dB
<b>SIGNAL-TO-NOISE RATIO</b>		
Wideband, unweighted, referred to full power output	>108 dB	>108 dB
“A” weighted	>116 dB	>116 dB
<b>GAIN</b>	25.7 dB	25.7 dB
<b>TOTAL HARMONIC DISTORTION</b>	<0.02% at 1 kHz, at 250 W, 8 Ohms <0.15% at 20 kHz, at 250 W, 8 Ohms	<0.02% at 1 kHz, at 250 W, 8 Ohms <0.15% at 20 kHz, at 250 W, 8 Ohms
<b>INPUT IMPEDANCE</b>		
Single-ended	50 kOhms	50 kOhms
Balanced	100 kOhms	100 kOhms
<b>INPUT SENSITIVITY</b>		
Single-ended or balanced	2.32 V rms	2.32 V rms
<b>OUTPUT POWER</b>	250 W rms per channel at 8 Ohms 500 W rms per channel at 4 Ohms	250 W rms per channel at 8 Ohms 500 W rms per channel at 4 Ohms
<b>OUTPUT VOLTAGE</b>	47 V rms or 133 V peak-to-peak	47 V rms or 133 V peak-to-peak
<b>OUTPUT CURRENT</b>	20 A peak	20 A peak
<b>SLEW RATE</b>	80 V/ $\mu$ s	80 V/ $\mu$ s
<b>OUTPUT IMPEDANCE</b>	<0.060 Ohms at 20 Hz <0.067 Ohms, 20 Hz to 20 kHz	<0.060 Ohms at 20 Hz <0.067 Ohms, 20 Hz to 20 kHz
<b>DAMPING FACTOR</b>		
Referred to 8 Ohms	>130 at 20 Hz, at 8 Ohms >120, 20 Hz to 20 kHz at 8Ohms	>130 at 20 Hz, at 8 Ohms >120, 20 Hz to 20 kHz at 8Ohms
<b>POWER CONSUMPTION</b>		
Stand-by	2 W	2 W
High Current Stand-by	40 W	50 W
Idle	90 W	125 W
Maximum	2400 W	2400 W
<b>HEAT OUTPUT</b>		
Stand-by	7 BTU/hr.	7 BTU/hr.
High Current Stand-by	140 BTU/hr.	170 BTU/hr.
Idle	310 BTU/hr.	430 BTU/hr.
Maximum	3100 BTU/hr.	3100 BTU/hr.
<b>INPUTS</b>	2 single-ended via RCA connector 2 balanced via XLR connector	3 single-ended via RCA connector 3 balanced via XLR connector
<b>OUTPUTS</b>	2 pair WBT binding posts	3 pair WBT binding posts
<b>DIMENSIONS</b>	17.5 in. W x 7.6 in. H x 19 in. D 438 mm W x 193 mm H x 486 mm D	17.5 in. W x 7.6 in. H x 19 in. D 438 mm W x 193 mm H x 486 mm D
<b>WEIGHT</b>		
Shipping	92 lb., 34.8 kg	95 lb., 43 kg
Unit only	77 lb., 41.6 kg	80 lb., 36.2 kg

All operational features, functions, specifications, and policies are subject to change without notification.

---

EVOLUTION e SERIES AMPLIFIERS

302e AND 402e STEREO  
403e THREE-CHANNEL  
600e AND 900e MONAURAL  
OWNER'S REFERENCE  
V 1.0

KRELL INDUSTRIES, LLC  
45 CONNAIR ROAD  
ORANGE, CT 06477-3650 USA

TELL: 203-298-4000 • FAX: 203-891-2028

E-MAIL: [sales@krellonline.com](mailto:sales@krellonline.com)

<http://www.krellonline.com>