

# Evolution of Instrumentation for Detection of the Raman Effect as Driven by Available Technologies and by Developing Applications

Fran Adar, Ph.D. - Jobin Yvon Horiba

Professor Michel Delhaye - Technical University of Lille

Edouard DaSilva, Ph.D. - Jobin Yvon Horiba

Waters Symposium

Pittcon 2003



[www.jyhoriba.co.uk](http://www.jyhoriba.co.uk)

**HORIBA** GROUP

EMISSION

FLUORESCENCE

FORENSICS

GRATINGS & DEM

OPTICAL SPECTROSCOPY

RAMAN

THIN FILM

# Time Line - 1920-1960

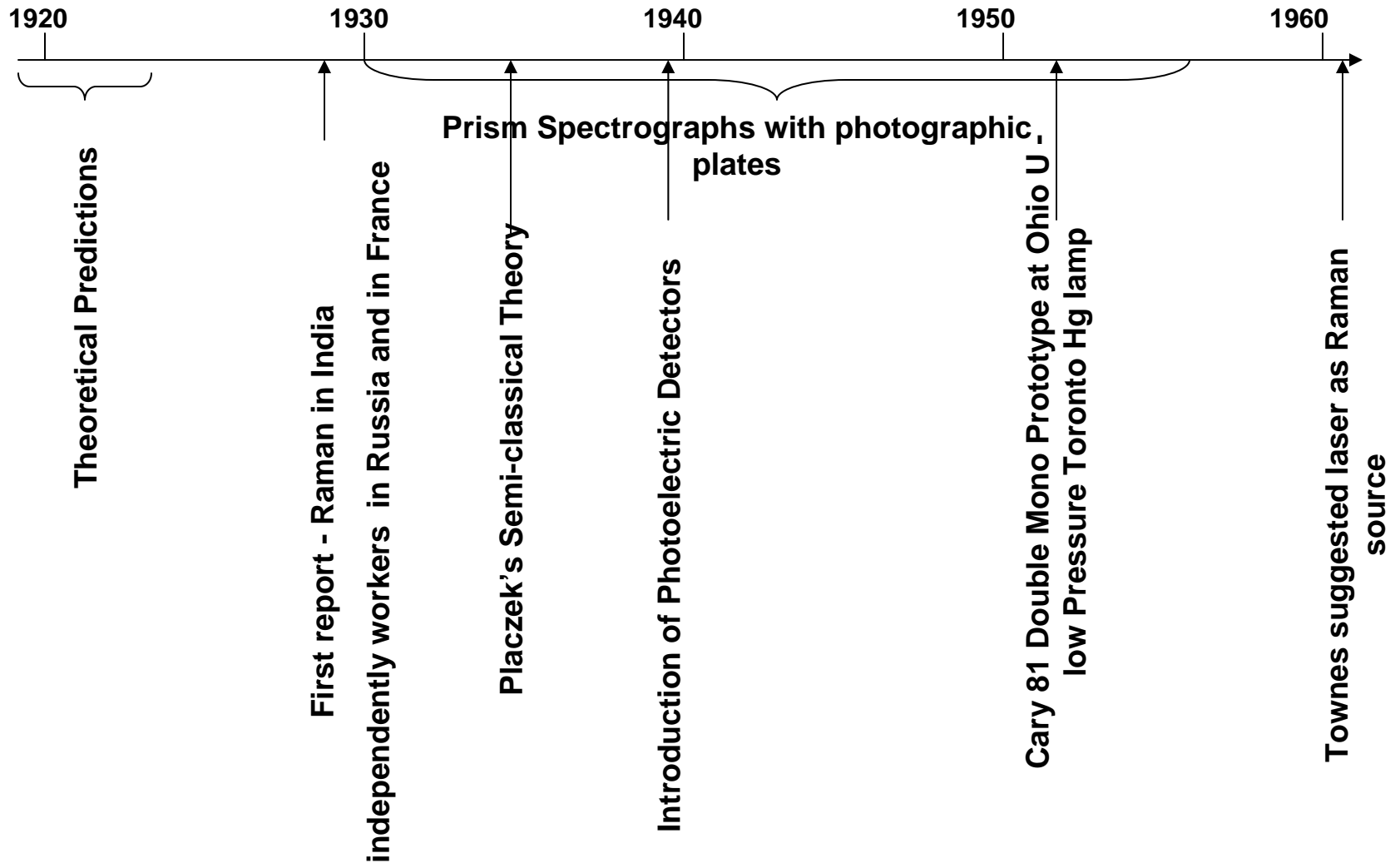

# Time Line - 1960-2000+

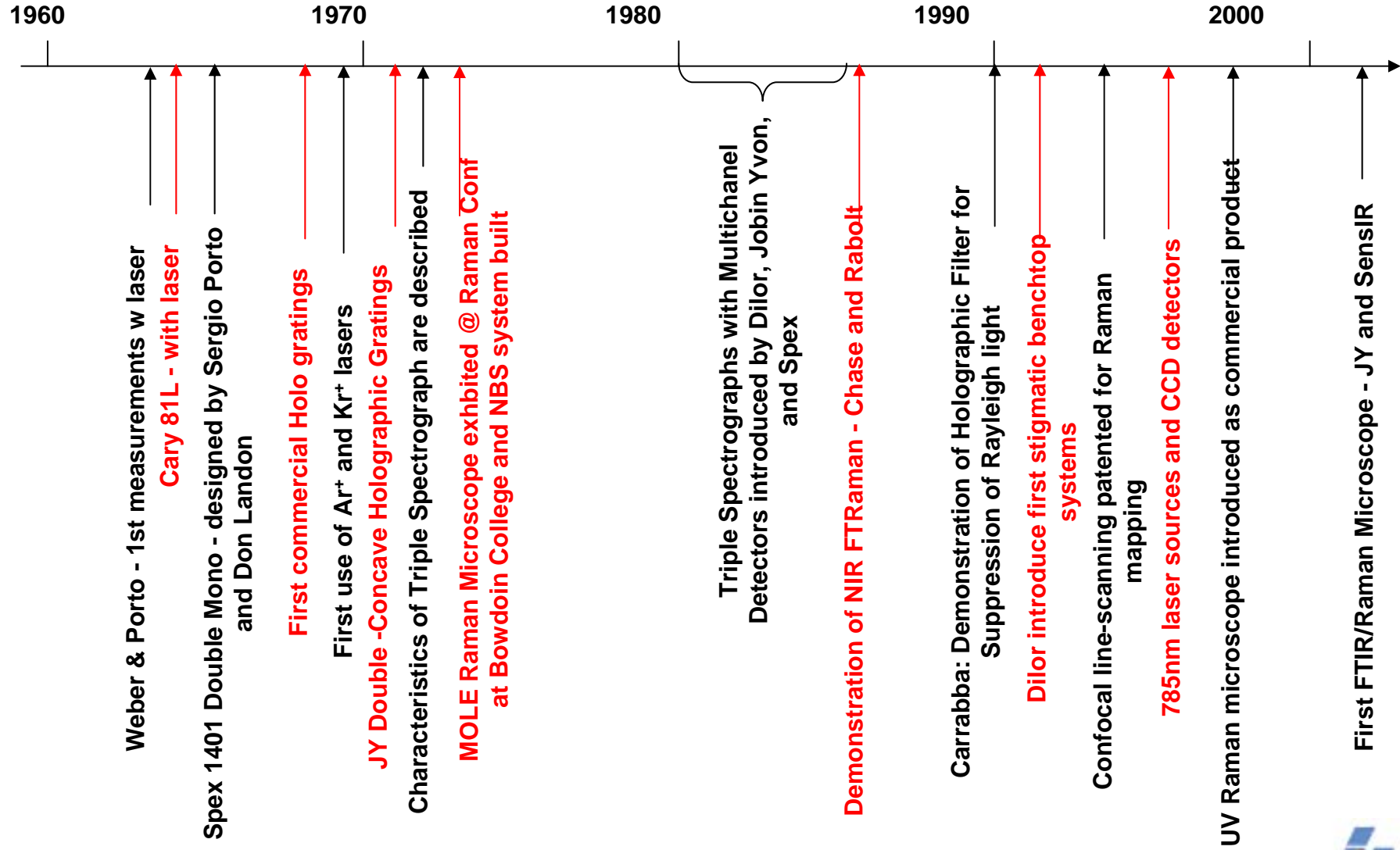

# History

- 1922-7: Predictions of molecular light scattering by Raman, Smekal, Kramers and Heisenberg, Cabannes and Daure, Rocard, and Schroedinger and Dirac
- 1928: Independent reports of the Raman Effect by CV Raman and shortly later by French and Russian groups
- 1930: CV Raman is awarded the Nobel Prize
- Raman's system: filtered sunlight, prism spectroscope, visual observation - later filtered Hg light and photographic plate
- Early work:
  - organic liquids and gases - Annal der Physik/Chem, 1930 100's of spectra are shown with the chemistry described; G Hertzberg, Molecular Spectra and Molecular Structure, II. Infrared and Raman Spectra of Polyatomic Molecules, 1945 - 100's of compounds studied with rigorous interpretations
  - inorganic solids - S.D. Ross Inorganic Infrared and Raman Spectra, 1972 - results from 40's, 50's, 60's
  - solid state physics, incl. semiconductors - W. Hayes and R. Loudon, 1978
- During early period there was much more activity in Raman spectroscopy than IR absorption because Raman was relatively easier than IR!



# Raman's Spectrograph with Photographic Plate and 1st Spectra Published in Indian Journal of Physics



From C&E News, p. 103,  
January 18, 1999

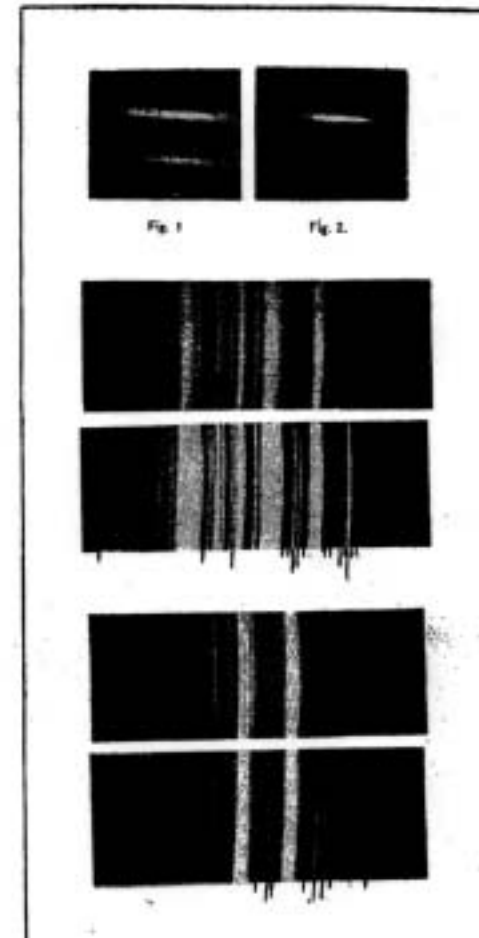

# Historical Curiosity

Raman's lifetime interest in color of the sea and gemstones led to his measuring the spectrum of diamond as one of the earliest materials examined.

Currently the study of diamond and hard carbon films is one of the most active areas.

1. DLC (diamond-like carbon) is used to coat all computer hard discs. The Raman signature is being correlated with the tribological qualities of the films.
2. Parameters of the Raman spectra (peak position, linewidth, carbon background) are correlated with the quality of diamond films.
3. A new technique has been developed to convert brown diamond stones to bright white gems. These GE Pol diamonds can be characterized by recording the UV-excited low temperature PL (photoluminescence) which must be measured on a Raman system.



# The Challenge to Record Raman Spectra

To detect a signal that is weaker than the excitation signal by at least 6 to 8 orders of magnitude

Practically this means that the “wings” from the elastically scattered light (the laser wavelength) will overwhelm the desired signal at the shifted wavelengths.

During the 30's, 40's and 50's, the “problems” that we commonly experience - fluorescence and stray light - were avoided because the samples were extensively purified (multiple distillations) after preparation - as much as 3 months for total preparation. [Particles in solution would produce a flash of light that would ruin the plate.]

During the earliest period spectra were typically recorded with prism spectrographs, Hg lamps, and photographic plates, integrating sometimes for days.

When people began to study **polycrystalline materials**, problems of stray light and luminescence (from impurities) became overwhelming obstacles to the acquisition of high quality spectra.



# The 30's, 40's and 50's

## PRISM SPECTROGRAPHS

**Commercial spectrographs** offered by Huet (Paris), Hilger and Watts (UK), and Steinheil (Germany) and ??? (Russian)

Very large **high index prisms** were available for these spectrographs. For example one of the Huet products used 3 prisms, with a base of 35 cm and a 35cm aperture, and used lenses from Mr.'s Jobin and Yvon<sup>1</sup>. These prisms were cooled slowly over a 1 year period in order to guarantee their quality!

1. M. Daure and M. Cabannes, Spectrographe a grande luminosite pour l'etude du spectre visible, Revue d'Optique, Theorique et instrumentale, t. 7, p.450-456 (1928)

Detection was either with a **photographic plate** or a **photomultiplier** tube. The photographic plate was sometimes mounted as close as a few mm's from the focussing lens, producing an f/0.9 system! "Baked plates", where a technique of heating the plates to increase sensitivity were used.





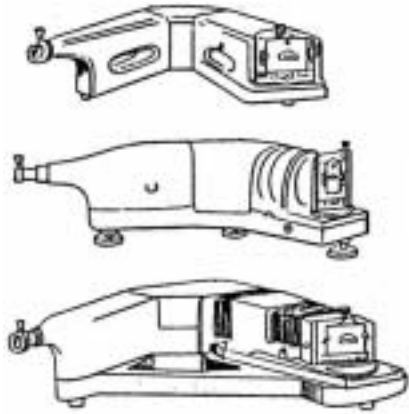

BII

- GRANDS SPECTROGRAPHES à Prismes
- SPECTROGRAPHES pour l'Effet Raman et l'Astrophysique



1940's

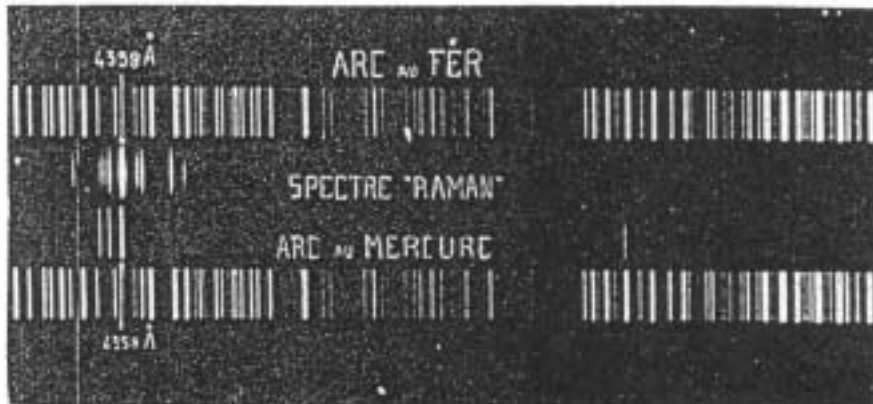

[www.jyhoriba.co.uk](http://www.jyhoriba.co.uk)

**HORIBA** GROUP

EMISSION

FLUORESCENCE

FORENSICS

GRATINGS & DEM

OPTICAL SPECTROSCOPY

RAMAN

THIN FILM

# HUET

	CI	BII
Aperture	F/0.7	F/4.7
# Prisms	1	2
Resolution	triplet 5507-5501-5497Å	80mm 3850-5900Å
Slit		symmetrically adjustable
Applications	astrophysics	Raman



# The Hilger E612 Optical Diagram

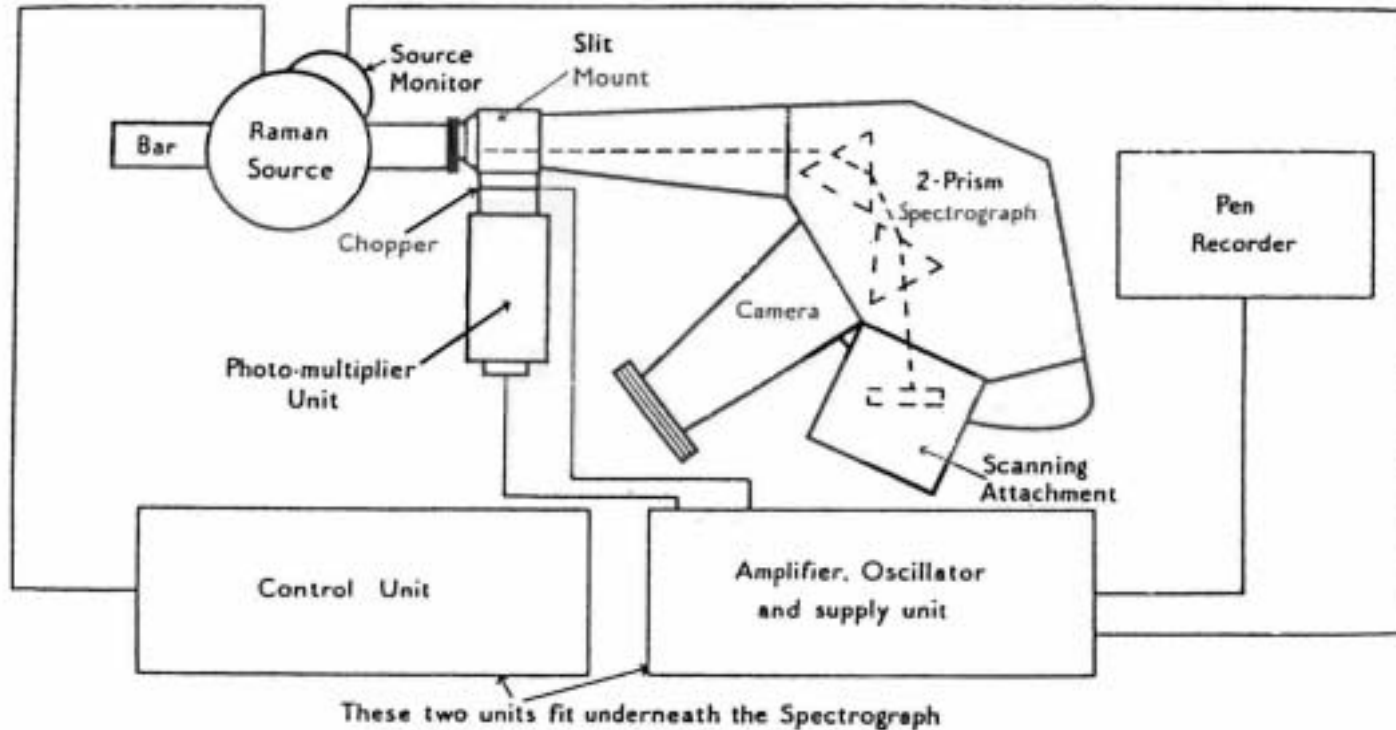

Double detector: Photographic plate for high sensitivity, and Scanning mirror producing subtracted dispersion on the slit and PMT, which was fixed in position. Designed by Menzies, scientific advisor.



# Hilger E612 Raman Spectrometer

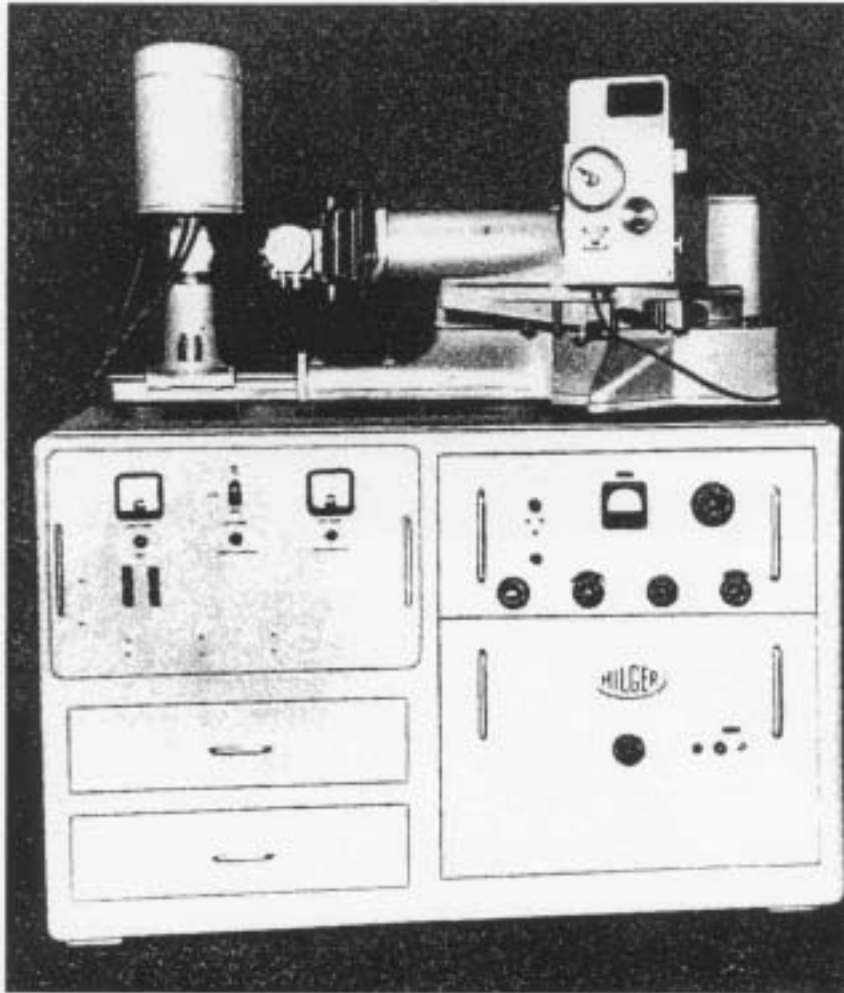

- Unit of 4 Hg Lamps
- Two-prism Spectrograph, 590mm focal length
- Dispersion  $68\text{cm}^{-1}/\text{mm}$  at  $435.8\text{nm}$
- Photographic or photoelectric detection (EMI PMT)

Circa 1955



## The Prism Chamber of the Steinheil Raman Spectrometer

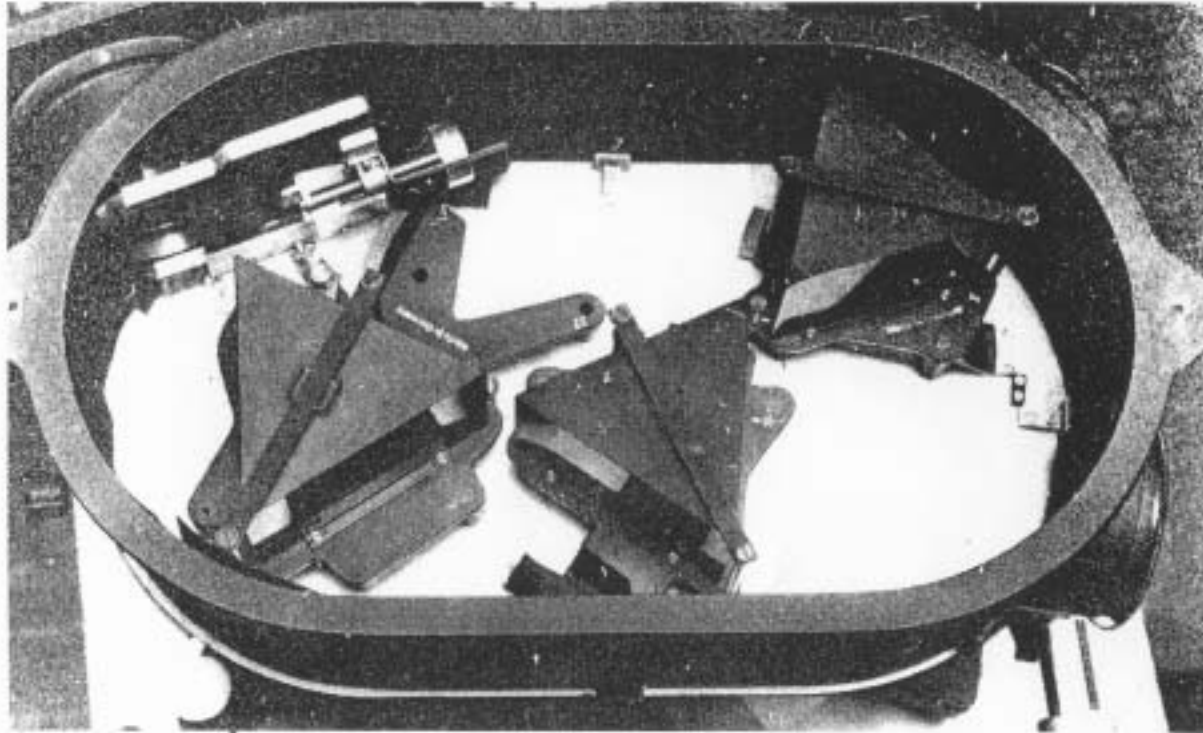

Medium sized, 3-4 cm prisms



[www.jyhoriba.co.uk](http://www.jyhoriba.co.uk)

**HORIBA** GROUP

EMISSION

FLUORESCENCE

FORENSICS

GRATINGS & DEM

OPTICAL SPECTROSCOPY

RAMAN

THIN FILM



# Steinheil Raman Spectrometer (1957)

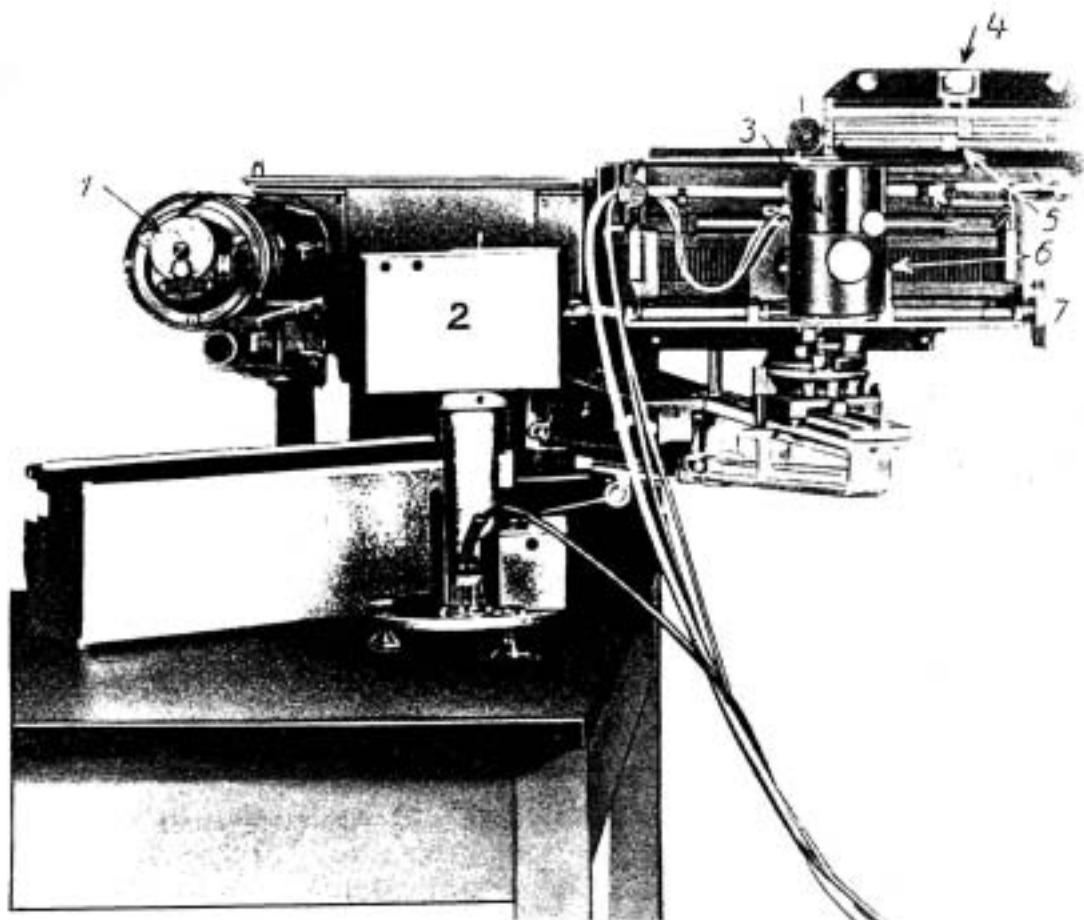

- High or Low Pressure Hg Arc Lamps
- 3-Prism Spectrograph:  
Collimator  $f=195$  or  $650$ mm  
Camera  $f= 225, 640, 1600$  mm
- PMT (RCA or EMI)
- PMT and slit were scanned across the focal plane



## Electronic System of the Steinheil Raman Spectrometer

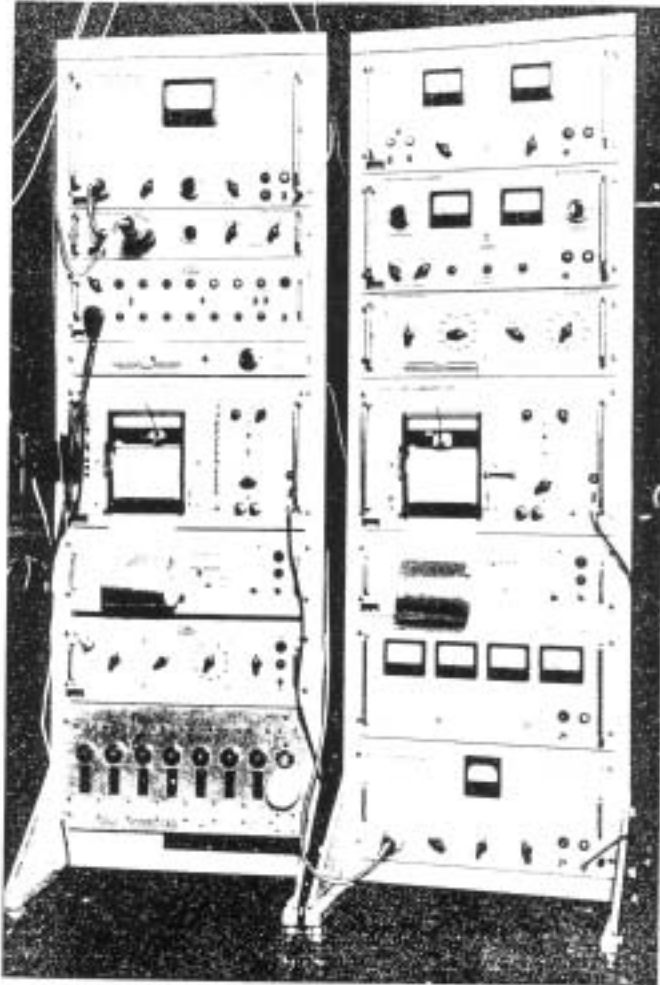

**Left**

- PM power supply
- Control panel
- Recorder
- Lamp Control

**Right**

- Integration
- 2-channel amplifier
- amplification and RC control
- Recorder
- PM power supply



# Mid 1950's to Early 70's

## Photoelectric Detection

Photon-counting PMT's developed for astronomy were used to optimize signal-to-noise (S/N) in order to take advantage of the ultimate noise limitation which is the Shot Noise from the signal itself - introduced in 1942, then integrated in Raman system in the 1950's

## Introduction of Laser as Source

HeNe - 1st suggested as a Raman source by Townes in 1961

1st used by Weber and Porto to study the gas phase in 1964

Ar and Kr - higher power, more "sensitive" range of spectrum

## Gratings as Dispersing Elements

**Ruled Gratings** Advantages included efficiency, higher angular dispersion, analytical description of dispersion, useful area (size). They offered better performance in the red. Double mono eliminated stray light - low efficiency of double was offset by doubled dispersion compared to single. Interferometric control to reduce ghosts and stray light was introduced ca. 1955

**Holographic Gratings** - To reduce the stray light levels and eliminate ghosts - Introduced commercially ca. 1972 - Large step in instrumentation development (eg. Concave grating mono) because of the inherent perfection of this optical element.



# Cary 81 Raman Spectrometer

The first easy-to-use analytical instrument.

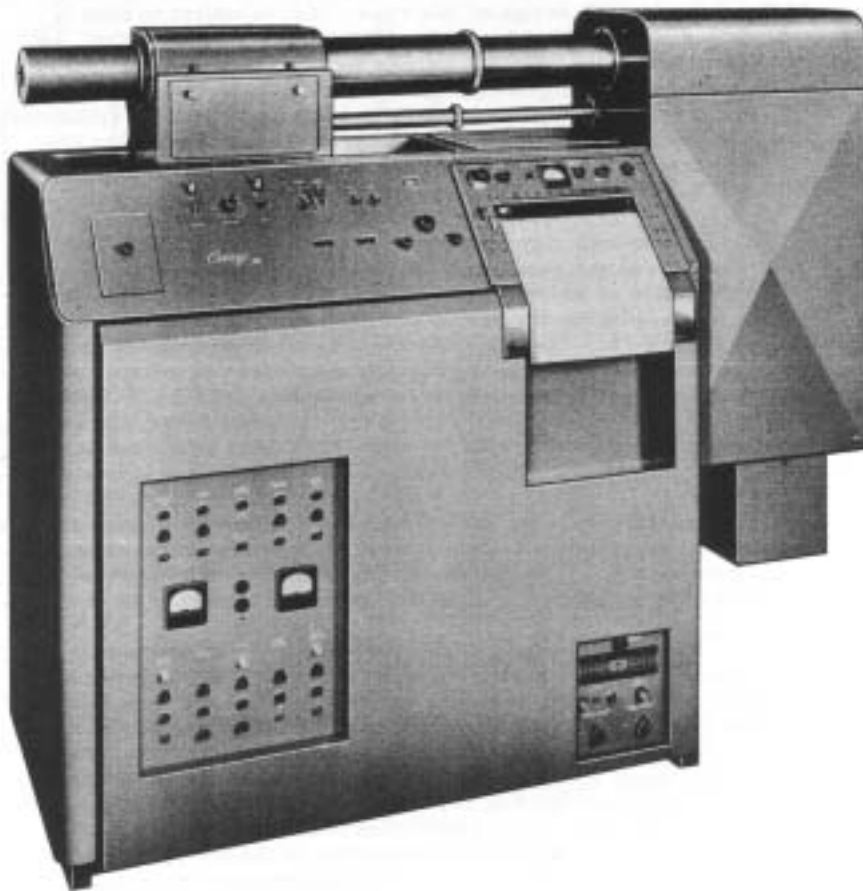

3kW helical Toronto Hg arc (low pressure for sharp lines, cooled by water low background)

Czerny-Littrow double monochromator with 1200 g/mm gratings [(100mm)<sup>2</sup>, 450nm blaze] - mechanically scanned in  $\text{cm}^{-1}$  (speeds from .0005 to 50  $\text{cm}^{-1}/\text{sec}$ )

Multi slit design to increase signal - plano convex lenses were added to correct for slit curvature and reduce aberrations

PMT - 1P28 type

Signal was chopped betw 2 PMT's and recombined to recover lost signal from chopping

Full rigorous discussion of Howard Cary's design considerations (sampling optics and spectrometer layout) appeared in a publication of the Applied Physics Corporation - 1954



# Toronto Arc Lamp

## Designed by Stoicheff in Toronto

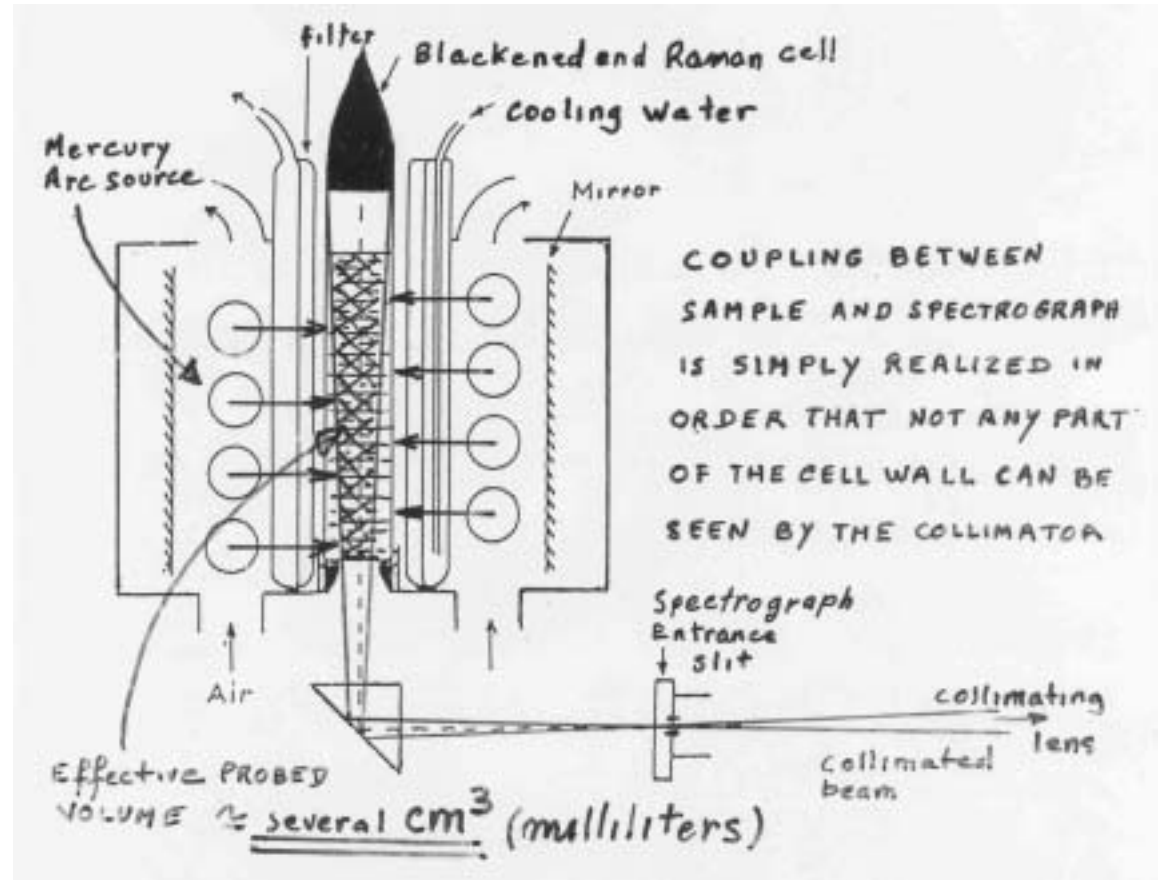
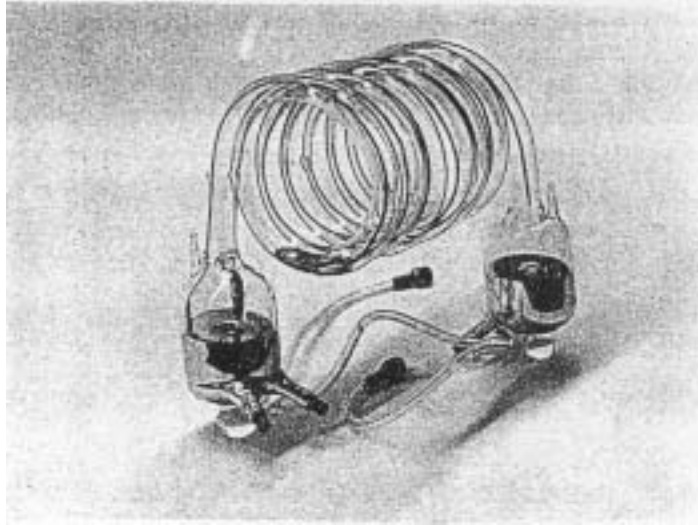

From archives of Prof. Paul Dhamelincourt



# Design Considerations of Cary 81

- Double mono
- Efficient light coupling from sample (surrounded by Hg arc) to spectrometer: conservation of light derived from Optical Sign Law of Abbe and LaGrange's Law of Optical Images, which we describe as conservation of etendu
- Cary evaluated system performance for various commercial instruments at the time (both grating and prism types) and was surprised to find that their "figures of merit" were similar despite differences in design and size.
- His evaluation indicated that an unsymmetrical entrance optics and image slicer would greatly improve the performance.
- He used a double slit arrangement to increase signal collection, and a rotating mirror to chop the light between 2 PMT's and gain in S/N.
- A reference phototube monitored the lamp intensity.



# Cary 81 Double Monochromator (Littrow) with Hg Toronto Arc Excitation

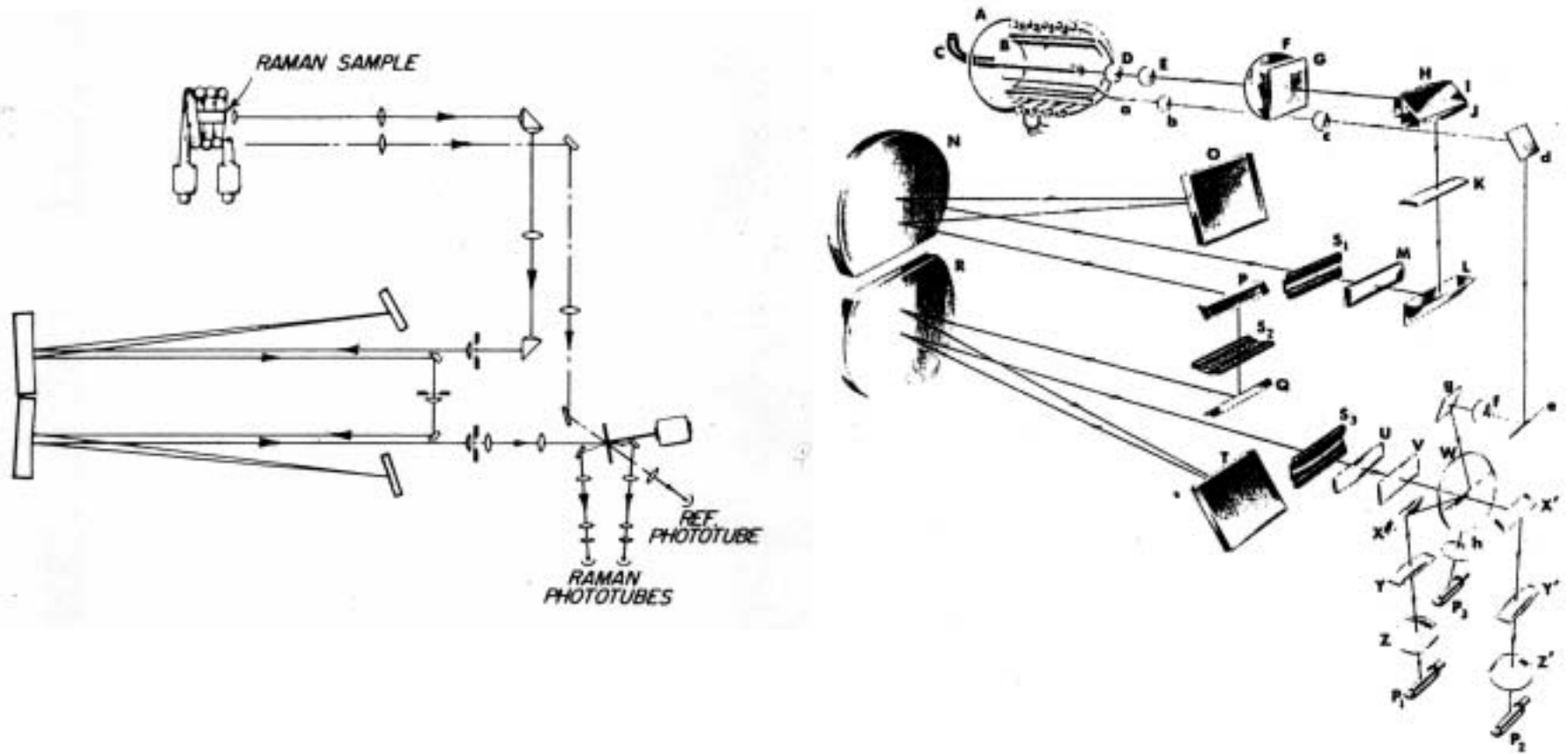

# Image Slicer

for converting large optical disc to segments that fit in slit

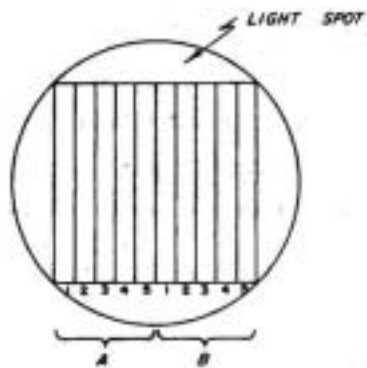

Goal

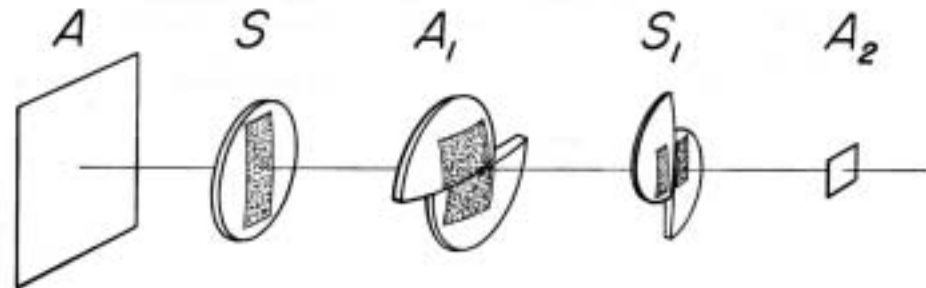
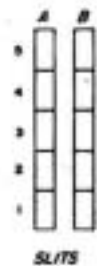

Principle of Operation





# Raman Spectrum of Benzene (0.25ml) Recorded on Cary 81 w Hg Arc Lamp: 10 cm<sup>-1</sup> slit, 10 cm<sup>-1</sup>/sec

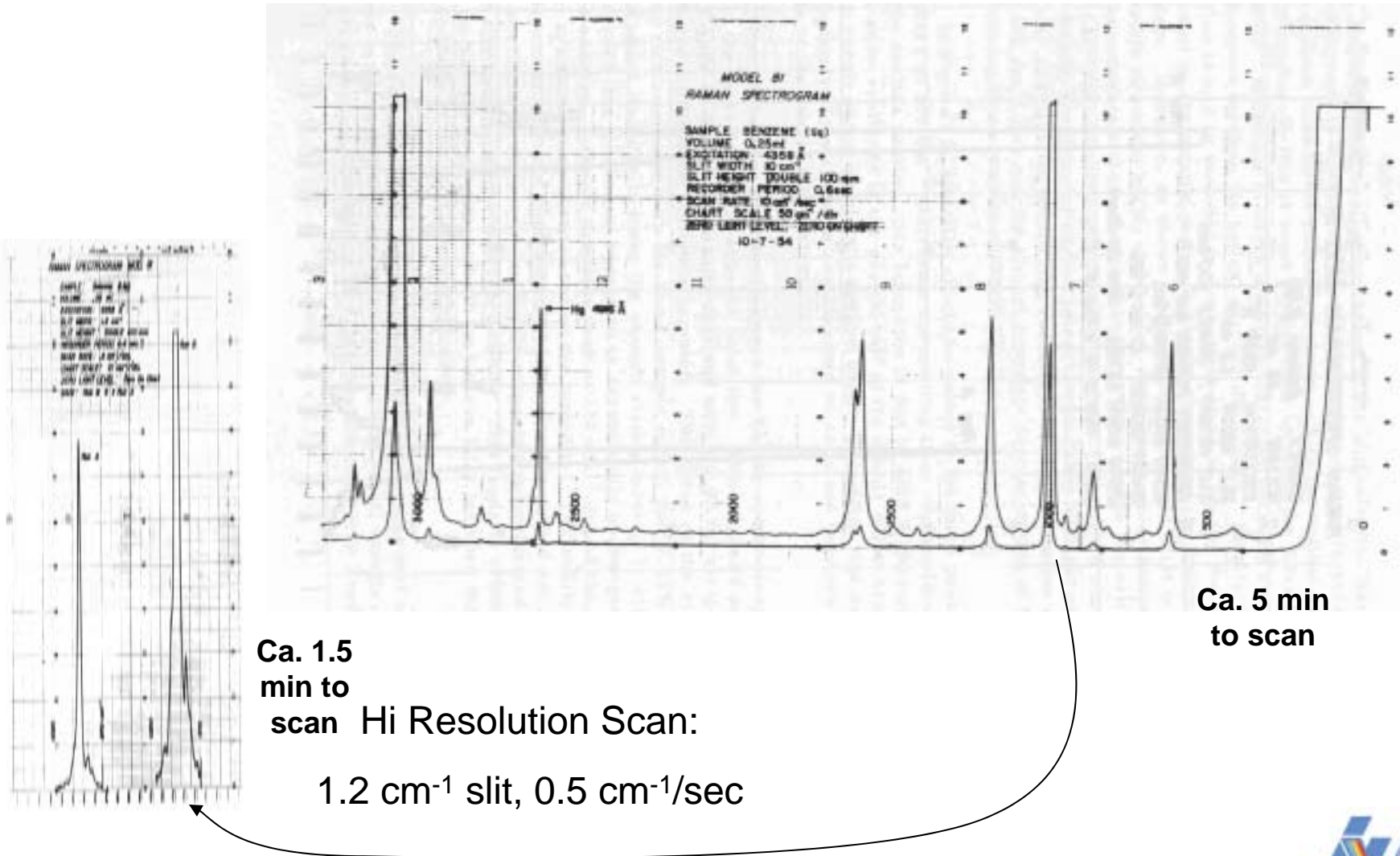

# Raman Spectra of Aqueous Solution

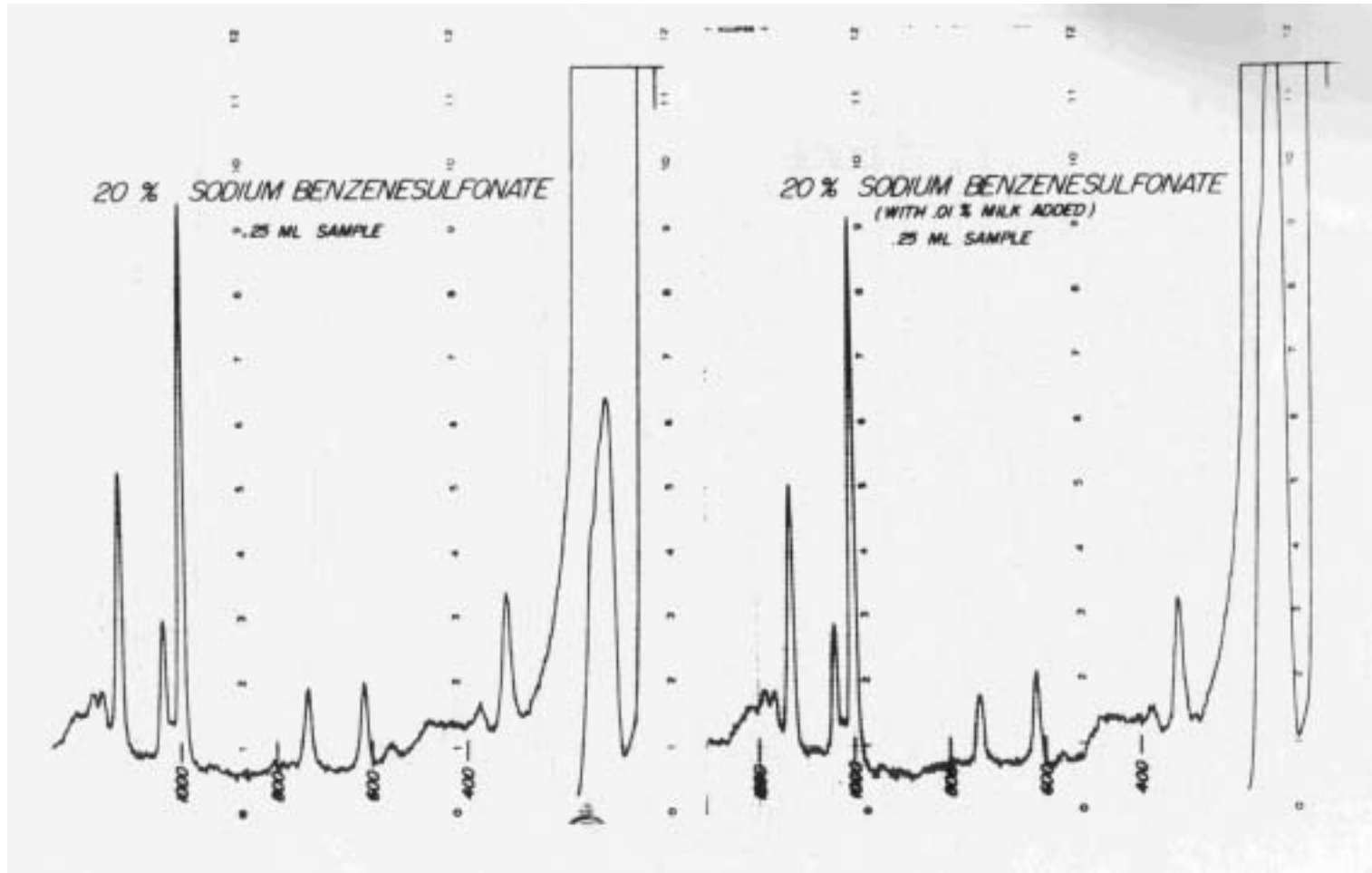

Note that addition of 0.01% milk increased turbidity resulting in stronger laser artifact at  $120\text{ cm}^{-1}$ , but no loss in ability to record spectrum.



# Perkin Elmer Raman Spectrometer - 1966

## - 1st Benchtop System

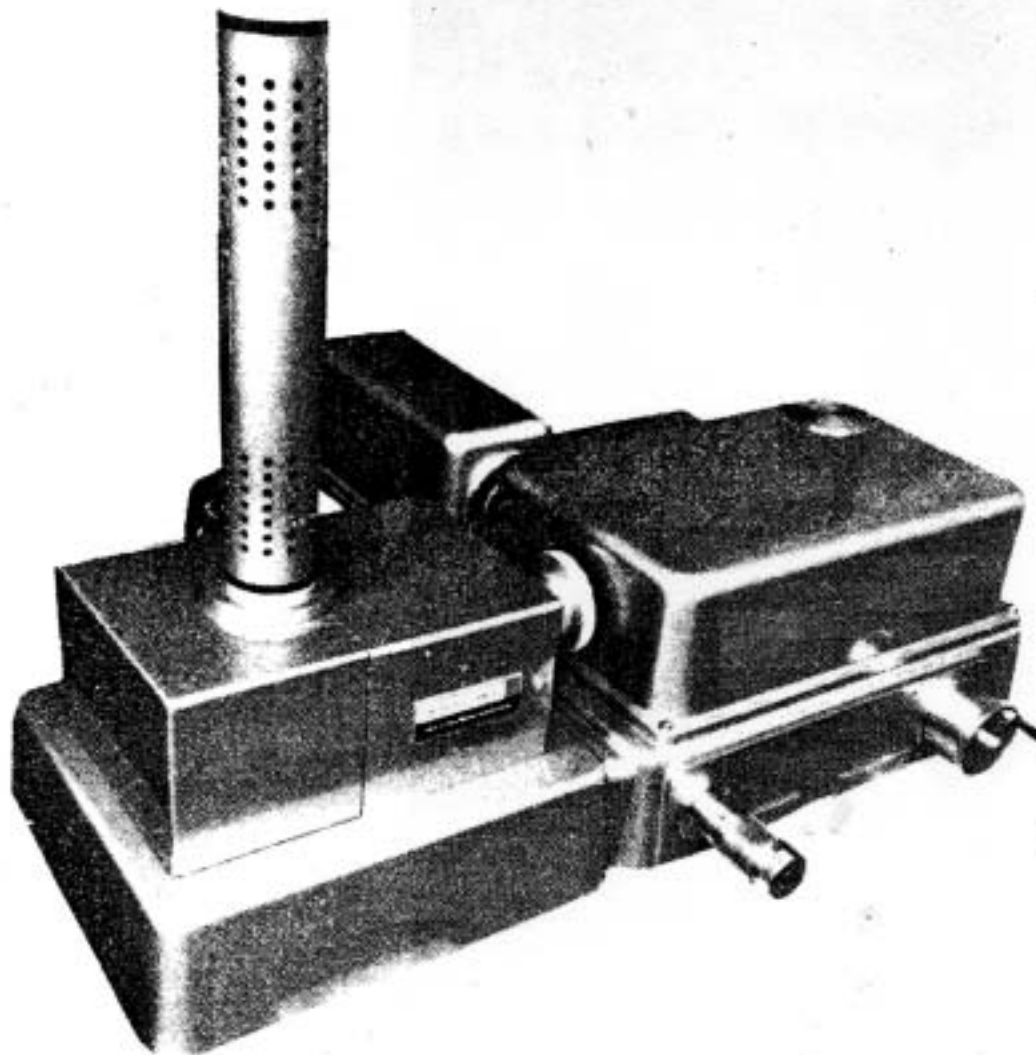

HeNe Laser - 4mw @633nm

1st multipass cell

Double pass grating  
monochromator (modified IR  
system with parabolic mirrors) -  
1440 g/mm - fl~300mm

Slit and motor drive were  
coupled to maintain constant  
resolution over scan range.

PMT with S20 response with  
chopper w synchronous  
demodulation





# Raman Spectra of Benzene and $\text{CCl}_4$ recorded on Perkin Elmer Scanning Raman System with 3 mw HeNe laser

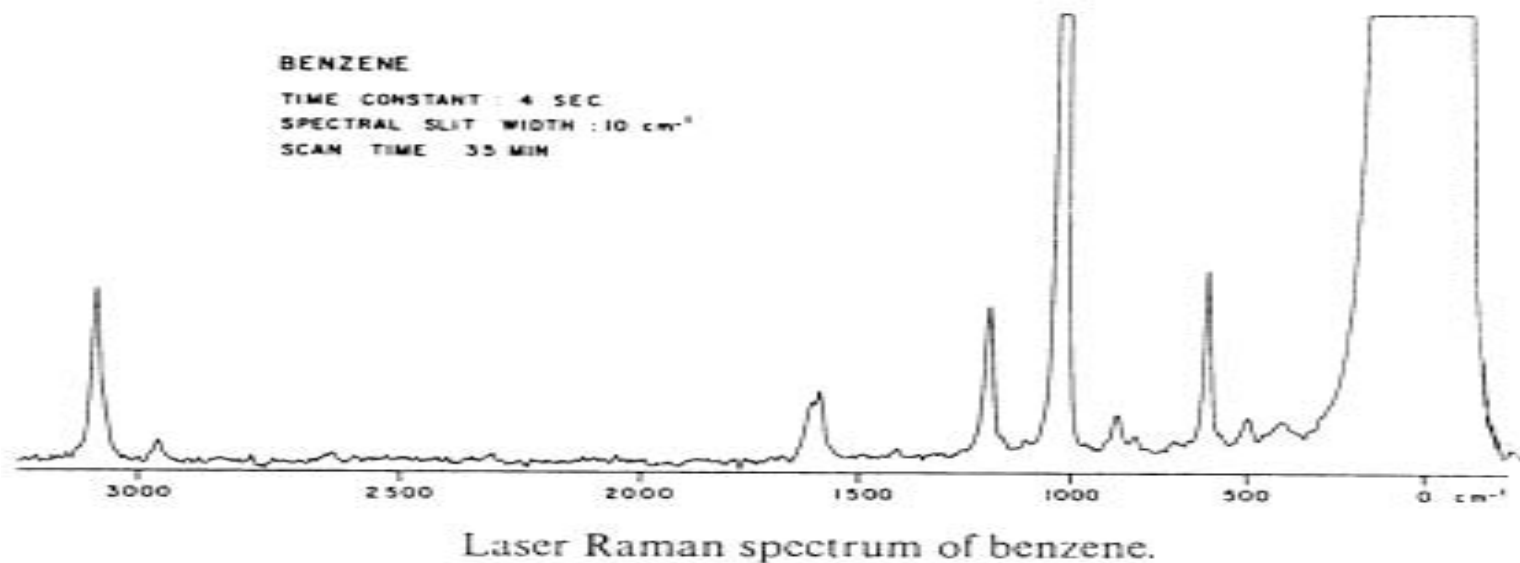
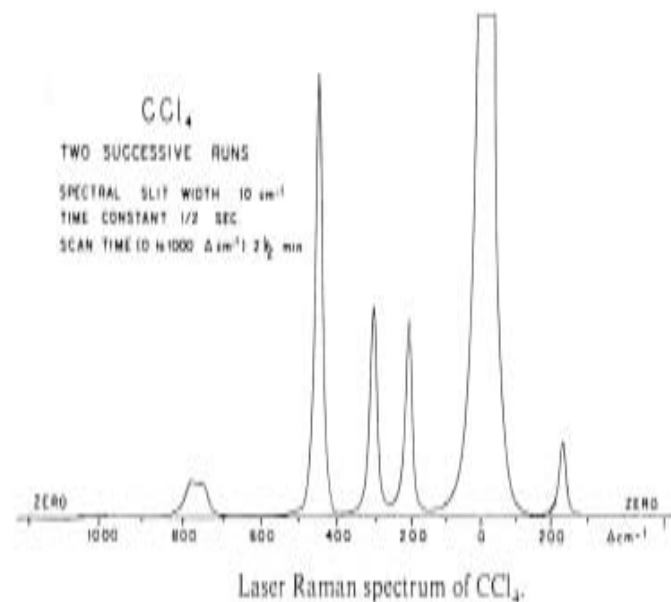

# Doubles and Triples with PMT

Multi-stage monos using Diffraction Gratings as the wavelength-dispersing element

Photoelectric detectors

- 1953 - Cary showed double additive CT\* at Ohio State U Conference - introduced commercial product, using Hg lamp (Cary 81)
- 1964 - Cary 82 - modification to accommodate the HeNe laser
- 1964 SpectraPhysics - double, additive Ebert (400mm)
- 1964 Steinheil - double, additive with lenses for collimation and focussing
- 1966 - Perkin Elmer benchtop double with HeNe
- 1967 - Spex - double additive CT
- 1967 - Coderg double (PH1)
- 1968 - Jarrell Ashe - double subtractive CT
- 1972 - Coderg - triple additive Sergeant Rozey mount - Delhaye design
- 1972 - Jobin Yvon - double additive - concave gratings w no mirrors between slits



# Spectrometer Types

optimized for simplicity, to minimize aberrations, etc.

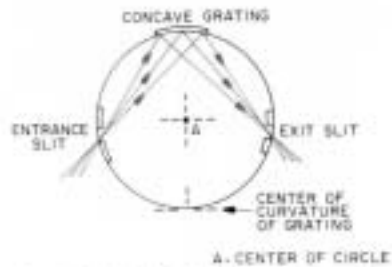

Fig. 4. Rowland Circle construction utilizes concave grating.

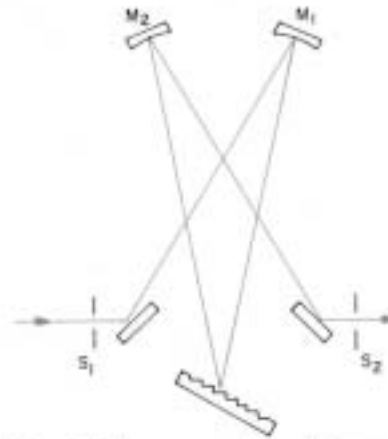

Fig. 6. Criss-cross version of Czerny-Turner.

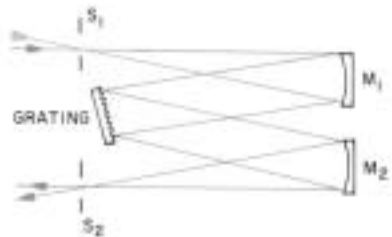

Fig. 5. Czerny-Turner construction uses two mirrors.

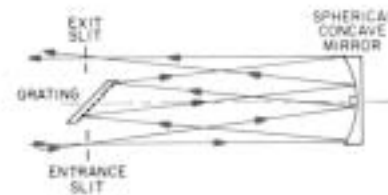

Fig. 7. Ebert construction uses a single mirror. This is the "side-by-side" version.

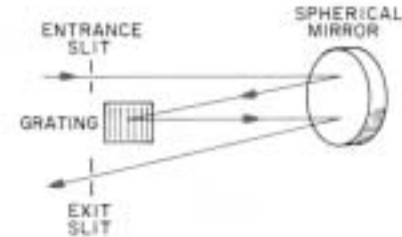

Fig. 8. "Over-and-under" version of the Ebert.

Sargent-Rozey analog with 2 tilted mirrors

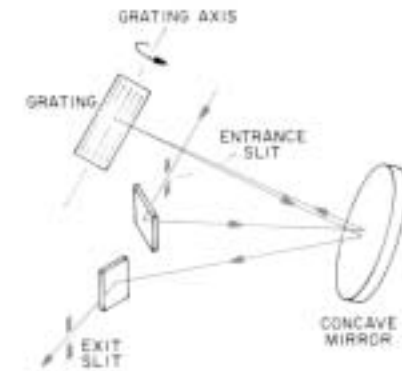

Fig. 9. "Out-of-plane" version of the Ebert.

Figure from Electro-Optical Systems Design, Feb. 1979, p. 32



# Optical Aberrations

**Spherical**

Effect spectral resolution, stray light levels, imaging capabilities. Concave mirrors used off-axis exaggerate these problems

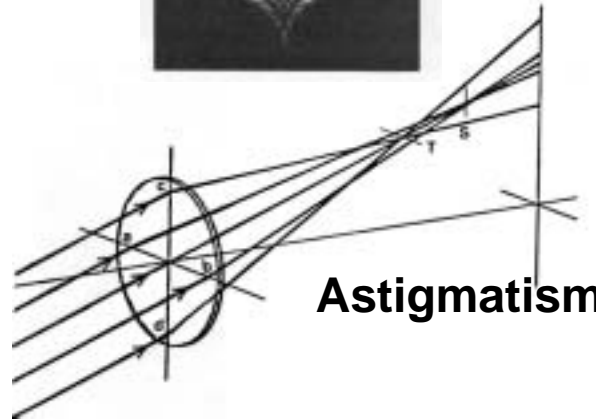
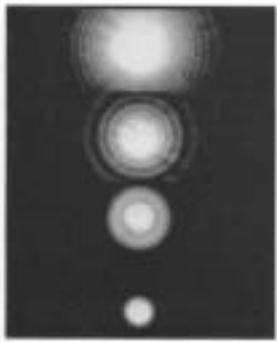
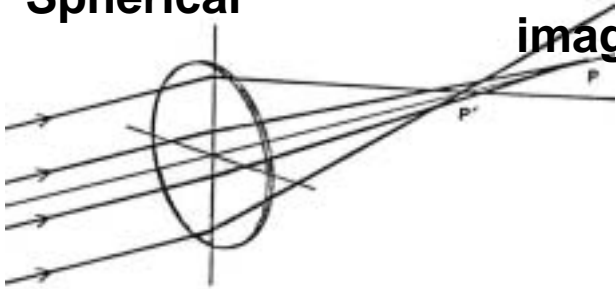

**Astigmatism**

**Coma**

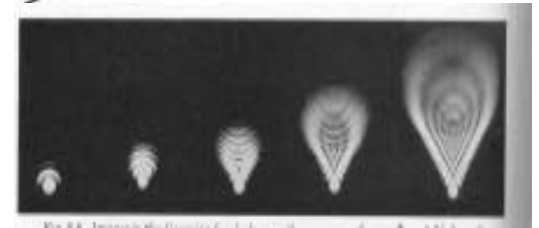
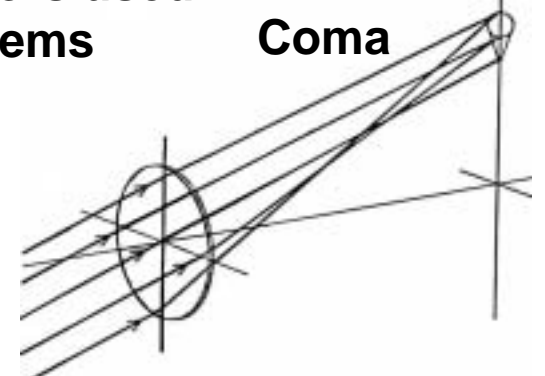

From Born and Wolf Fig. 9.5, 9.8, and 9.11,

and

WH Price The Photographic Lens, Scientific American, **235**, 2, 72-83 (1976)

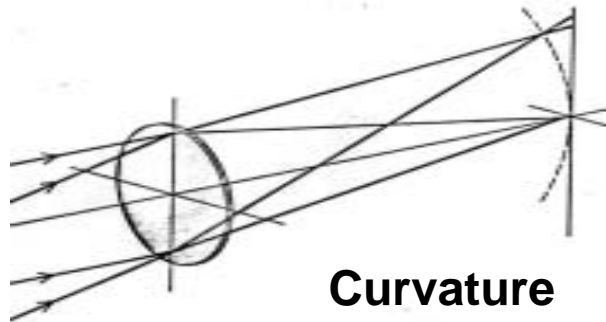

**Curvature**

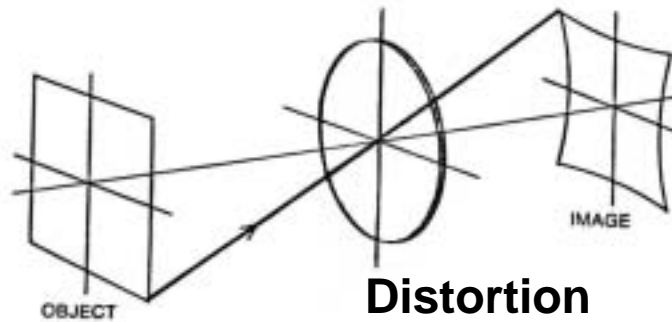

**Distortion**



# Aberrations Produced by Spherical Concave Mirrors

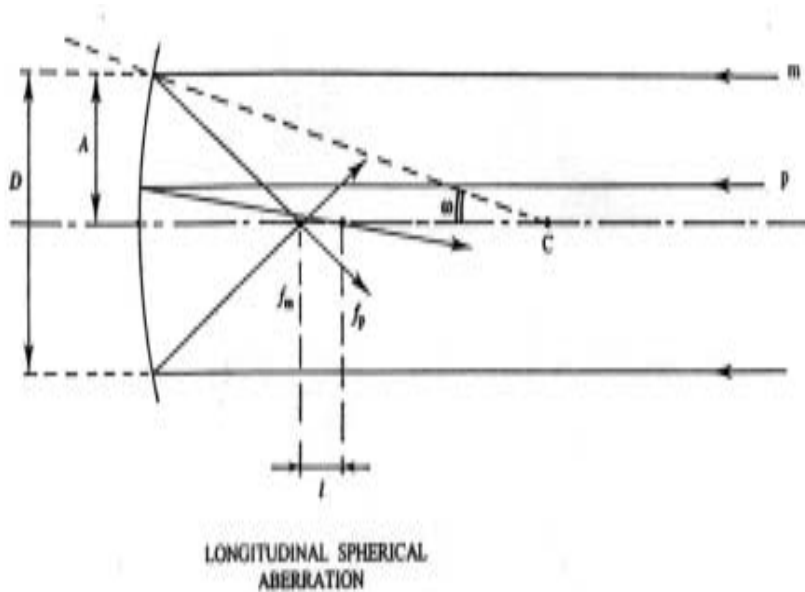

**Spherical Aberration**

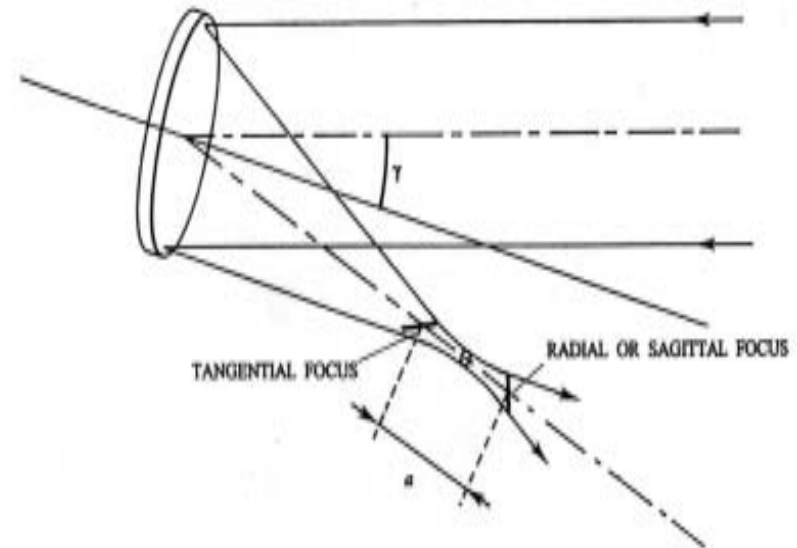

**Astigmatism**

Figures 28 and 29, Chap.3 Instrumentation by M Delhaye, J Barbaillat, J. Aubard, M Bridoux, and E DaSilva in Raman Microscopy, ed. G. Turrell and J. Corset (Academic Press, London 1996)



# Czerny Turner Design

## Goal was to Cancel Coma

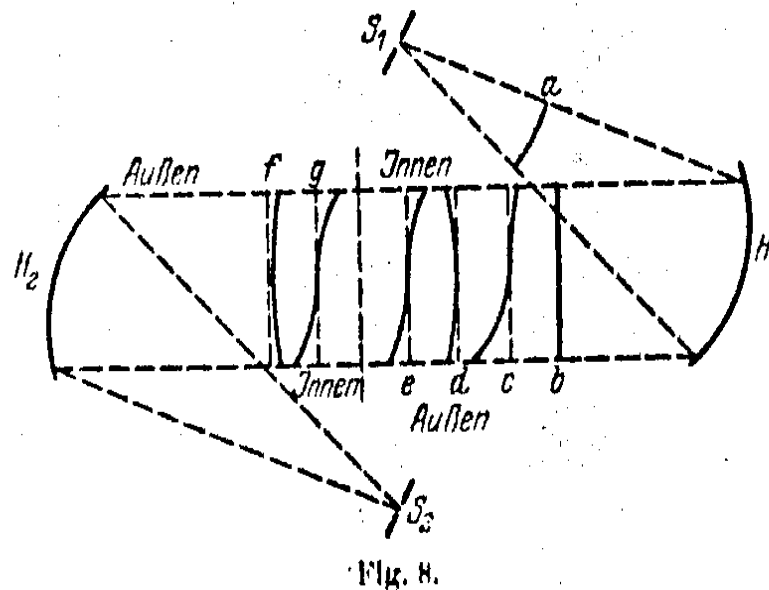

Mirror arrangement  
Compensates for  
distortion of plane  
waves



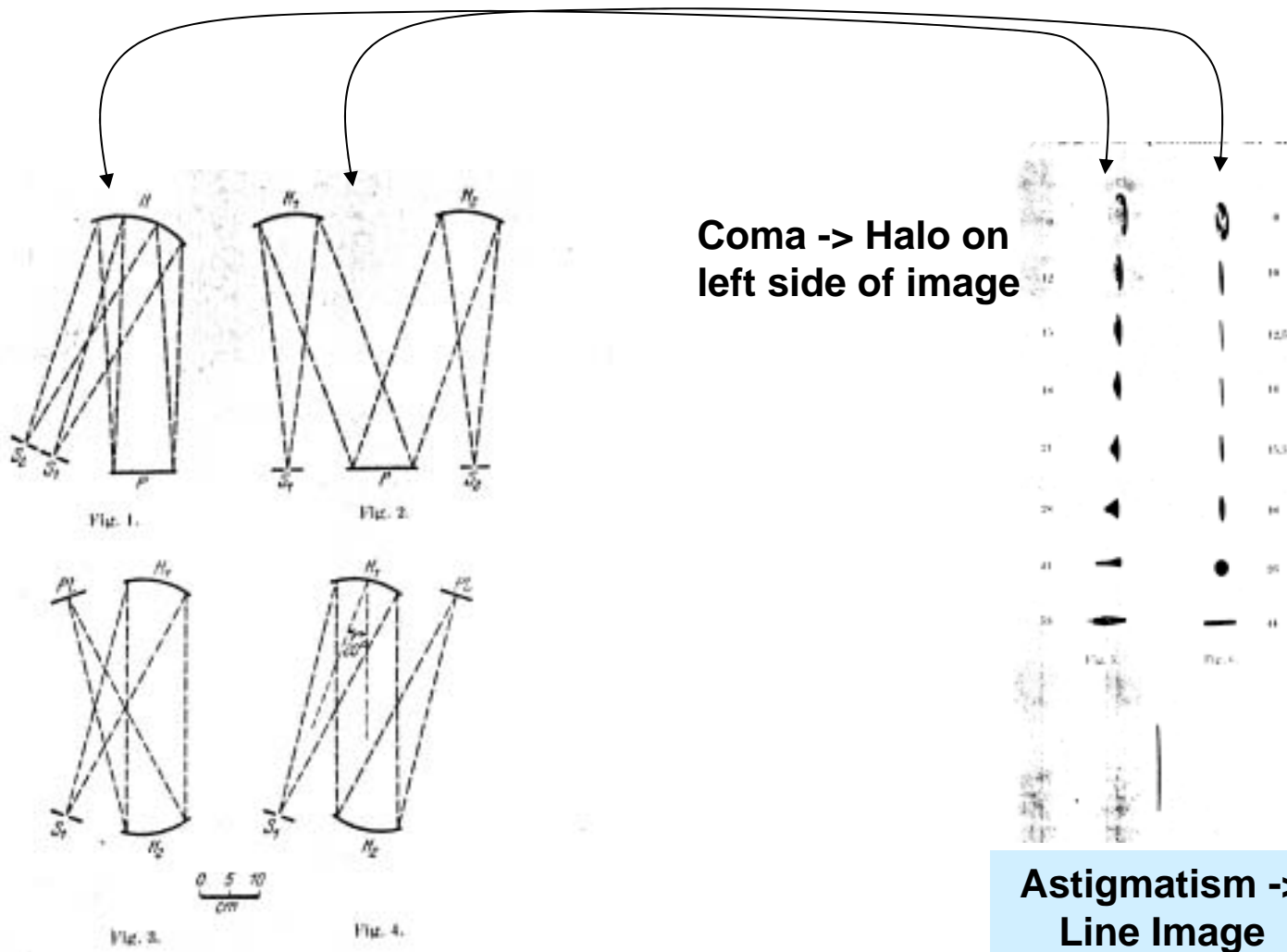

**Czerny Turner Design (on right side of figures) Eliminates Halo (on left side of foci)**





# Further Czerny Turner Developments

- **Asymmetrization** for further sharpening of slit image: Shafer, et.al Optimization of the Czerny Turner Spectrometer, J. Opt. Soc. Am **54**, 879-887 (1964)
- Further optimization for use as a spectrograph, ie., **flattening the focal surface**: J. Reader, Optimizing Czerny Turner Spectrographs: A Comparison between Analytic Theory and Ray Tracing, J. Opt. Soc. Am **59**, 9, 1189-1196 (1969) - **A flattened focal surface will be critical for use of multichannel detectors.**





# PRINCIPLE DESIGNS FOR MULTI STAGE SPECTROMETERS

## Czerny-Turner - Plane Gratings

Designed in 1930 to eliminate lowest order coma.

The plane of incidence of the mirrors is parallel to the dispersion direction.

Uses spherical mirrors off-axis -> sagittal and tangential focal planes: exit slit is placed in plane where the image is parallel to the slit dimension to optimize for spectral resolution.

## Sergent-Rozey - Plane Gratings

Alternative design to eliminate aberrations, but it takes up larger volume. Multiple stages can be stacked without need for extra mirrors, which maximizes throughput. See T800 triple scanning system for use with PMT.

## Concave Grating Spectrograph

Holographically recorded gratings eliminate grating “ghosts”.

Elimination of mirrors between spectrometer slits eliminated sources of “stray light” due to mirror imperfections



# Comparison of Czerny-Turner and Sergent-Rozey Spectrometers

(Use of one large mirror instead of two mirrors is called an Ebert mount.)

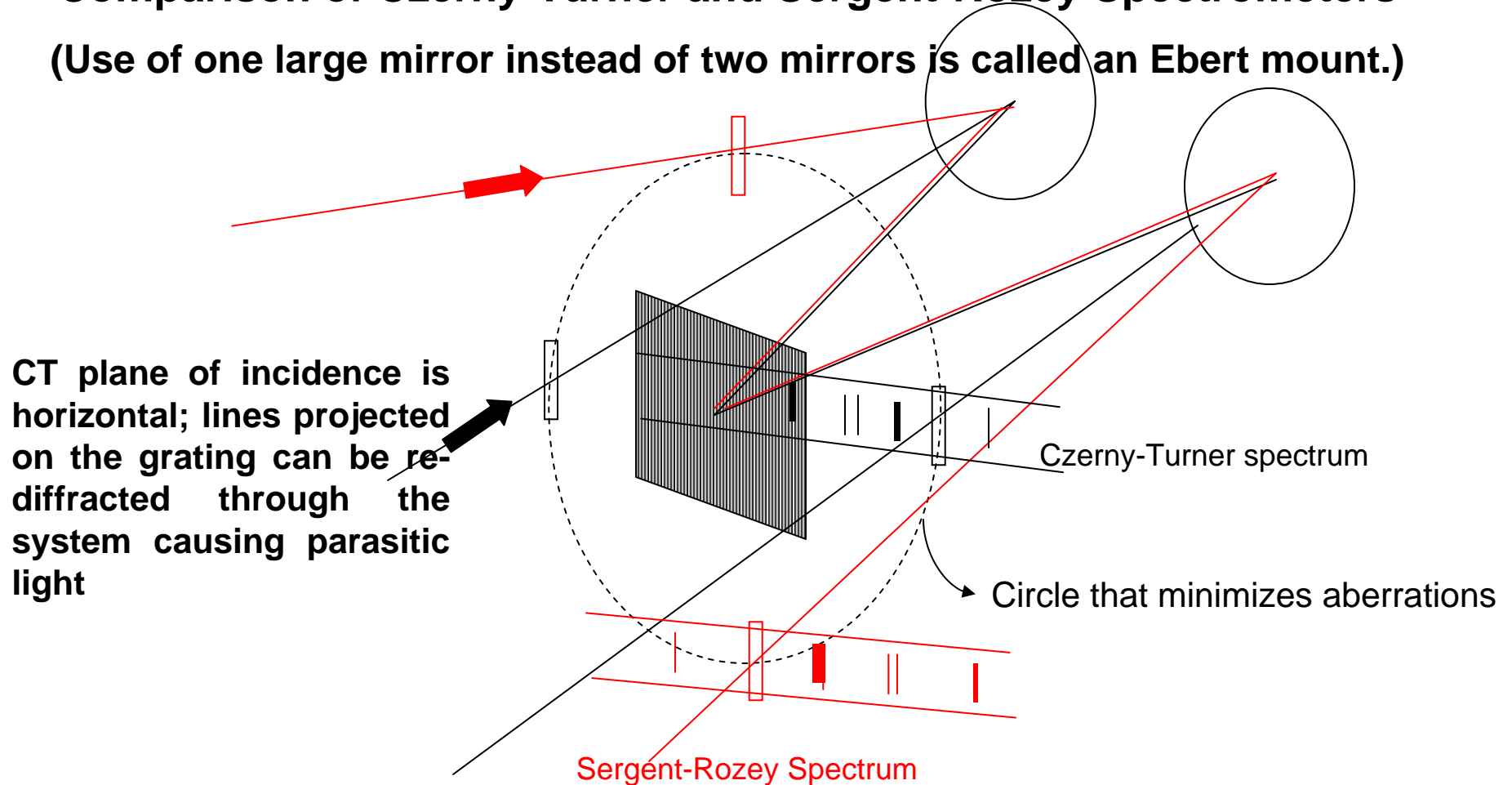

**SR plane of incidence is vertical and totally eliminates re-diffracted light and thus reduces stray light**



# Coderg T800

Triple scanning spectrometer based on Sergent-Rozey design. Minimized use of extra mirrors for transferring light from one stage to another, and minimized re-diffracted light.

Largest Sergent-Rozey design was a 5 stage spectrometer and produced the Brillouin spectrum as well as the Raman spectrum in the same scan. The system is currently running at U. Lyon.

M. Sergent-Rozey, Etude d'un Montage Ameliorant la Formation des Images dans un Spectrometre a Reseau, Revue d'Optique, t44, no 4, 193-203 (1965) and  
G. Arie, J-Cl. Lescouarch, et R. Demol, Entre un Double et un Triple Monochromateur en Spectrometrie Raman-Laser, Nouv., Rev. Optique Appliquee, t3 #5, 281-284 (1972)

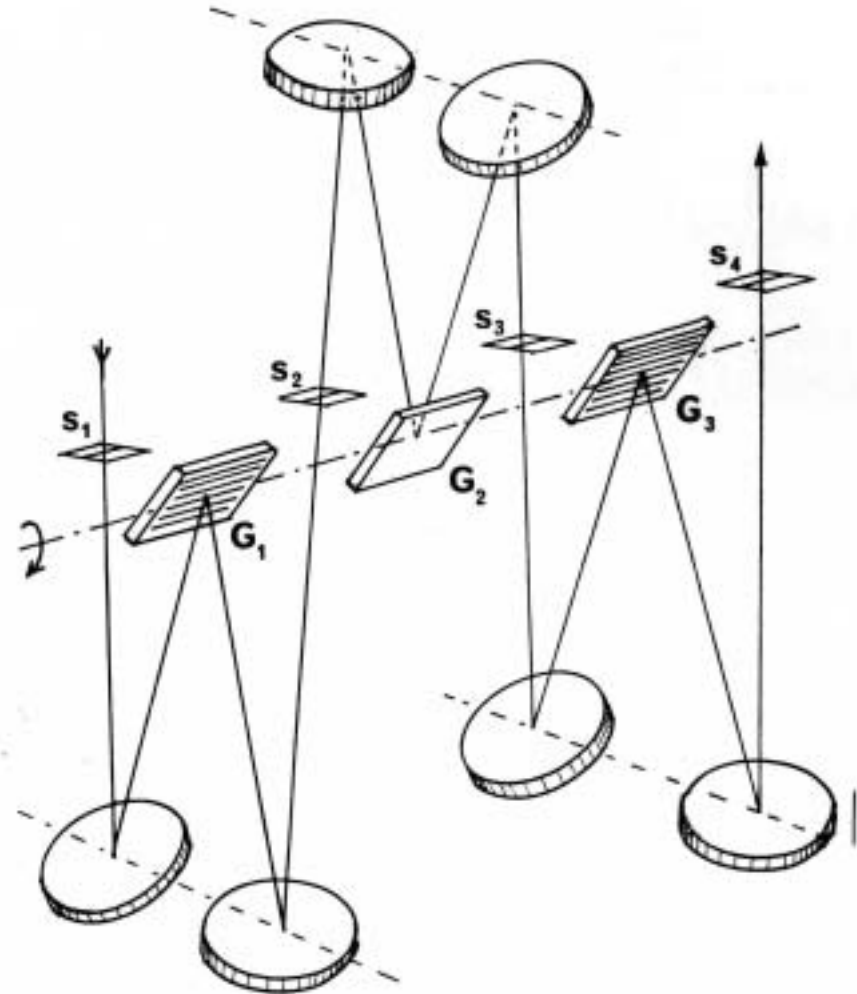

# Mechanically Ruled vs. Holographic Gratings

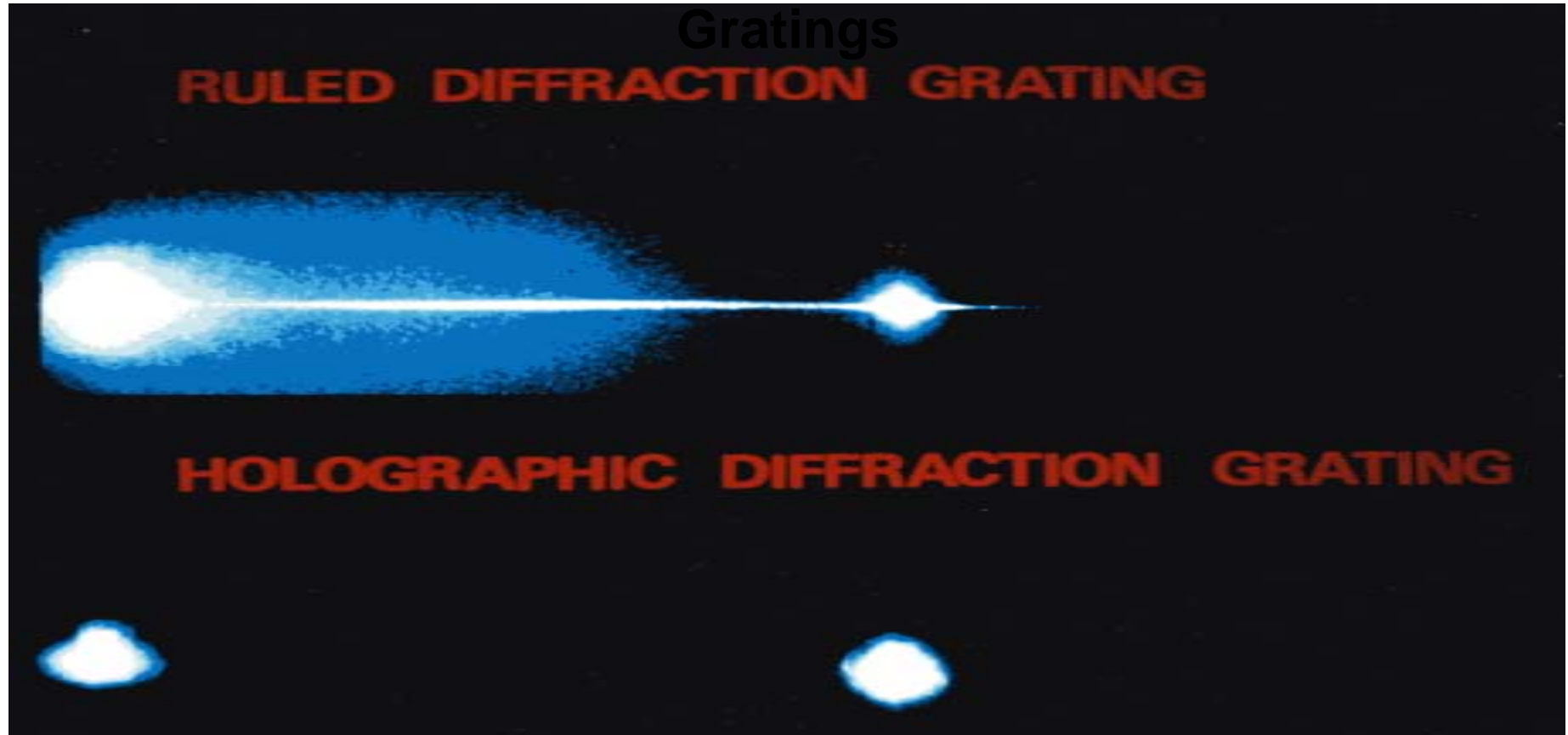

- Holographically recorded gratings reduce stray light levels by orders of magnitude totally eliminate ghosts which are artifacts of a particular ruling engine.
- Multistage grating spectrometers or spectrographs, using holographically recorded gratings record low frequency bands to  $5 \text{ cm}^{-1}$  from the laser



# JY HG2S Concave Grating Spectrometer

Gratings mounted on single shaft - no optical element inside of slits other than grating to further reduce stray light levels - spectra were recorded to  $5\text{ cm}^{-1}$  from the laser line

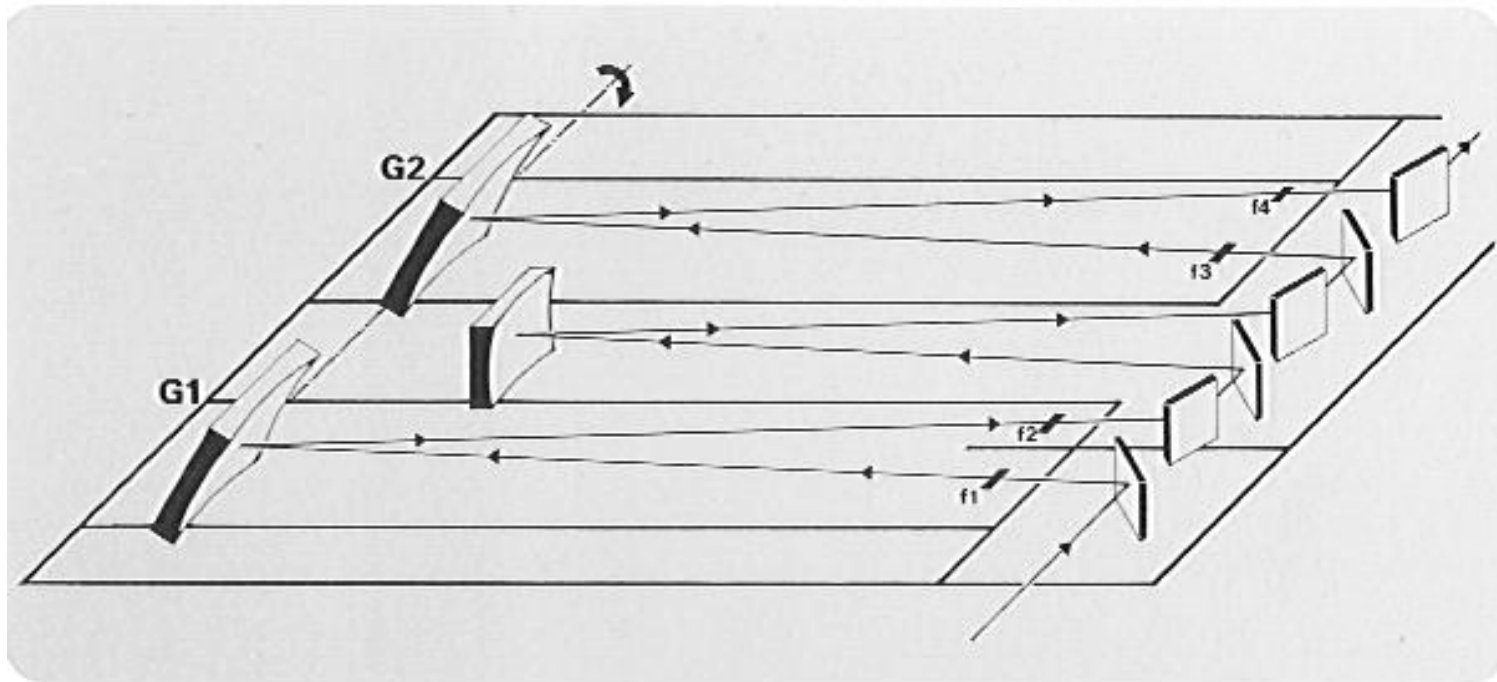

# Observation of LAM Mode in Polyethylene Oxide U1000 Double Mono with 1800 g/mm Holographic

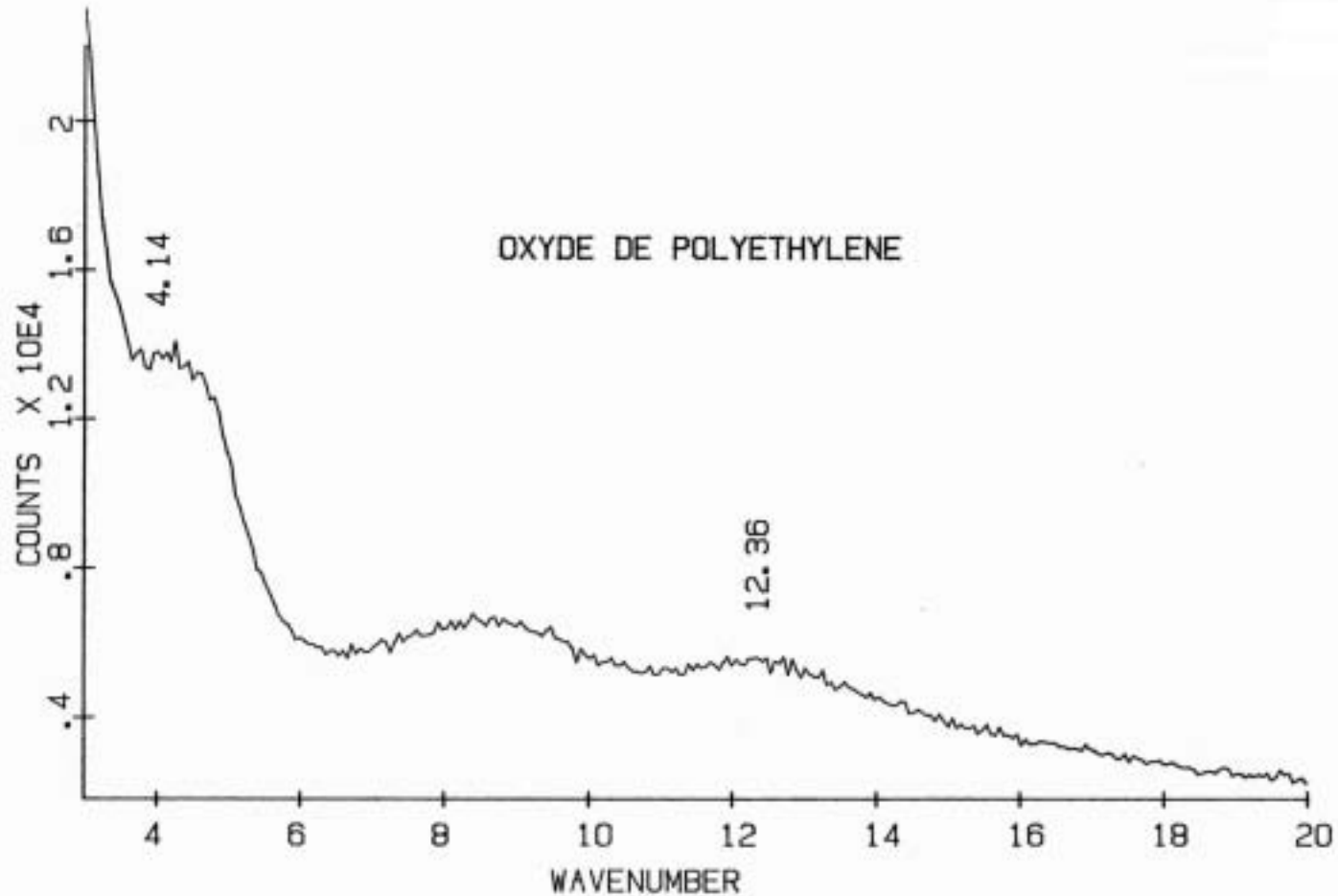

**Note: such critical results will depend on focal length as well as quality of optical elements**





# Brillouin Spectrum of $\text{SiO}_2$

recorded on U1000 with 1800g/mm holographic gratings

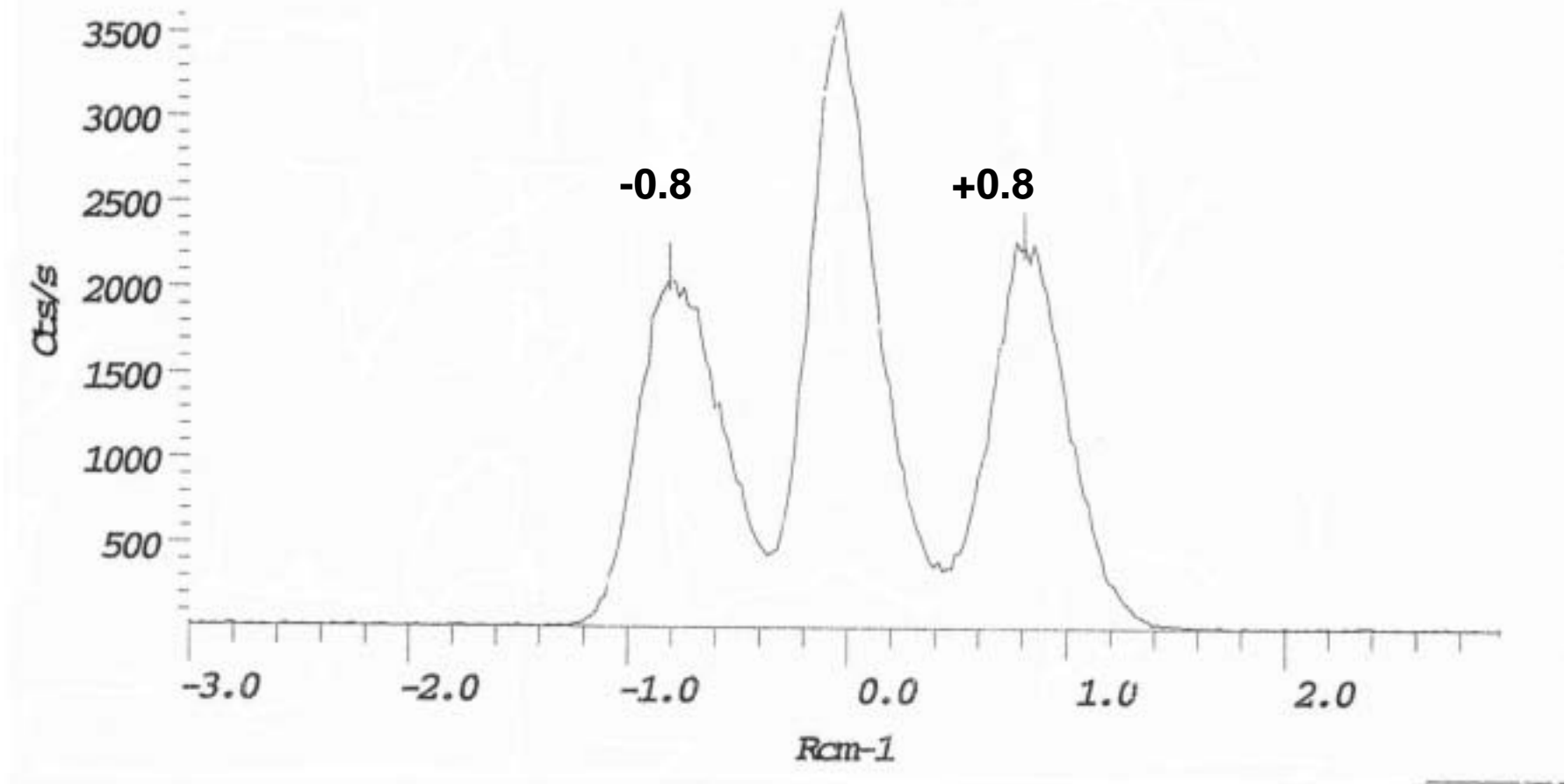

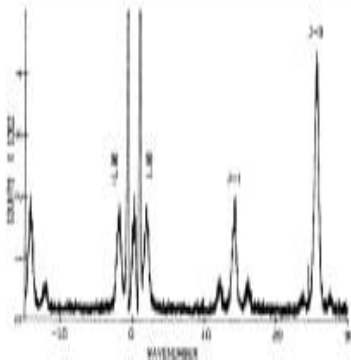
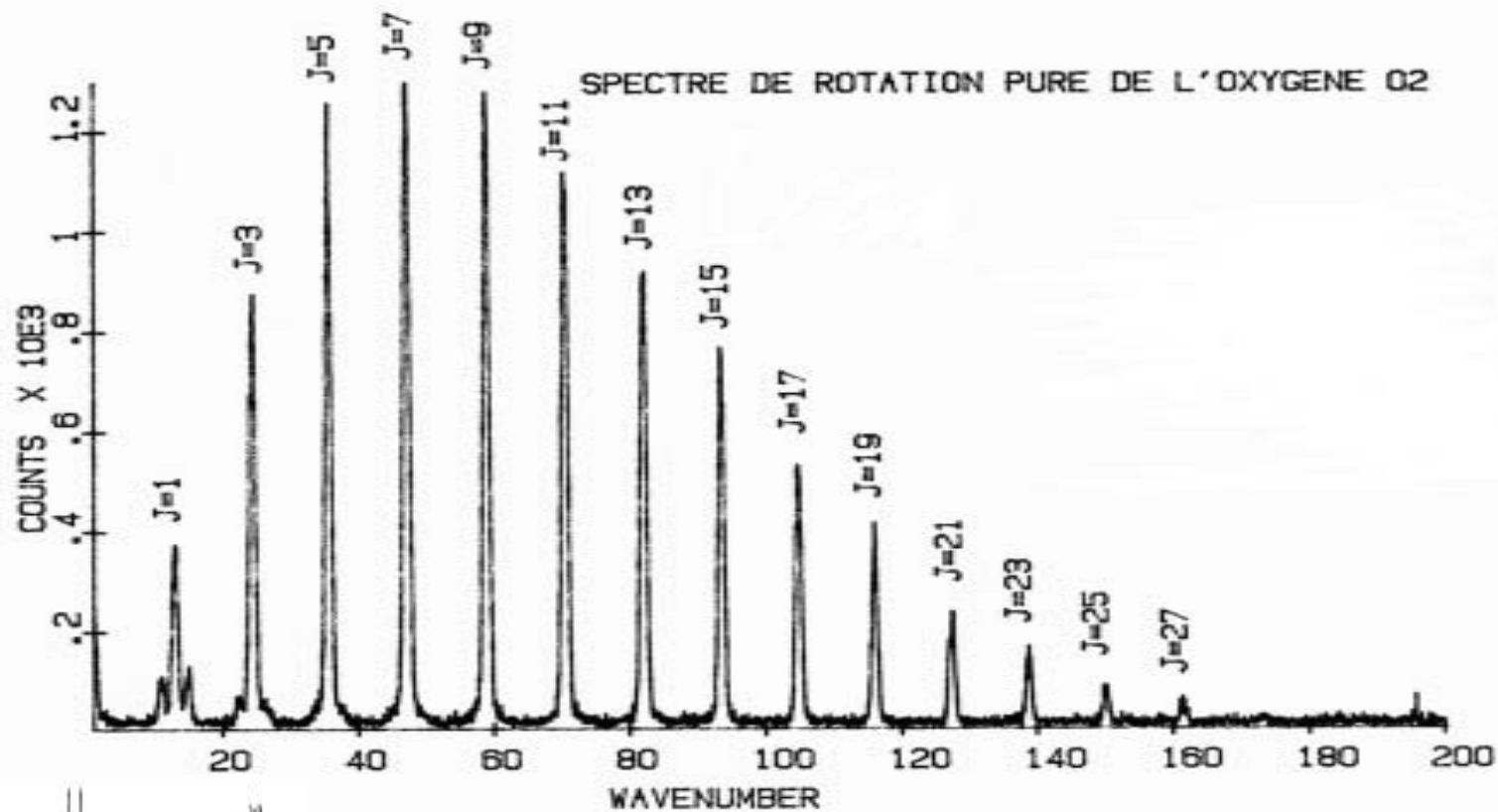

**Rotational Spectrum of O<sub>2</sub> recorded on U1000 with 1800g/mm holographic gratings**

**Note lines at  $\pm 1.96 \text{ cm}^{-1}$  and similar sidebands on J=1 and 3 rotational lines that have been assigned to spin transitions of the O<sub>2</sub> triplet**





## Drive System of Double Monos

If  $\lambda \sim \sin\theta_{\text{included}}$ , then  $\Delta\nu \sim \csc\theta_{\text{included}}$

**Cosecant drive:** # steps linearly related to wavenumber shifts which was a convenience when using **strip chart recorders**.

But the mechanical range is limited, which became an issue when low groove density gratings were to be mounted for increased coverage with multichannel detector. Practically this meant that a cosecant drive designed for an 1800 g/mm grating could be used with a 1200 g/mm grating with an Ar laser, but not with 600 g/mm.

**Sine drive:** Any groove density grating could be mounted. The wavenumber shift calibration is handled by simple arithmetic **calculations in computer**.



## Cosecant Arm

# DRIVE SYSTEMS

## Sine Arm

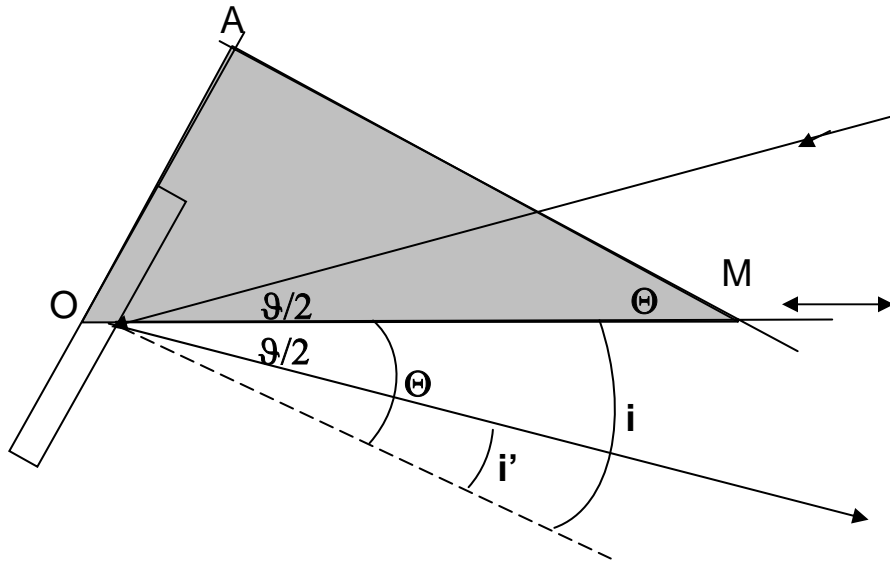

$$OM = x \quad OA = l$$

$$\sin i + \sin i' = kn\lambda = kn/\sigma$$

$$2\sin [(i+i')/2]\cos [(i-i')/2] = kn/\sigma$$

$$2\sin\theta \cos\phi/2 = kn/\sigma$$

$$\sigma = [kn/(2\cos\phi/2)] * [1/\sin\theta]$$

$$\text{with } \sin\theta = l/x$$

$$\sigma = [kn/(2\cos\phi/2)] * x/l = k'x$$

$$\Rightarrow v \text{ and } \Delta v \sim \sigma \sim x$$

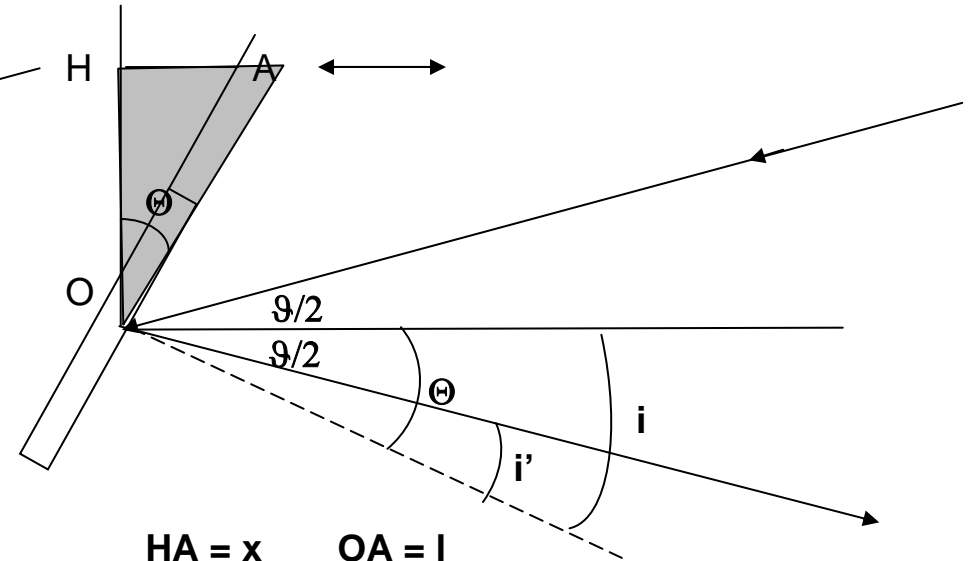

$$HA = x \quad OA = l$$

$$\sin i + \sin i' = kn\lambda$$

$$2\sin [(i+i')/2]\cos [(i-i')/2] = kn\lambda$$

$$2\sin\theta \cos\phi/2 = kn\lambda$$

$$\sigma = [2/(kn)]\cos(\phi/2) * \sin\theta$$

$$\text{with } \sin\theta = x/l$$

$$\lambda = kx$$



# Electronic Multichannel Detectors - Digital Analog of Photographic Plate

- **Imaging PMT** - good noise characteristics, but low dynamic range
- **Image Intensifier and Photographic Plate or Vidicon camera** 1964 (M.Bridoux, Application des Tubes Intensificateurs d'Image a la Spectrographie Raman Instantanee, Revue d'Optique **46**, #8, 389-416 (1967) - The properties of the Image Intensifier and various detectors were studied in order to follow chemical, kinetic changes in a high luminosity spectrograph.

- **IPDA - Intensified Photodiode Array** - 1978

Spectral sensitivity limited by photocathode

The size of the pixel and the array dictated the size of the spectrograph

1024 25 $\mu$ m x 2.5mm pixels - 0.5 to 2 cm<sup>-1</sup>/pixel -> 500 - 2000 cm<sup>-1</sup> coverage - some cross-talk from Image Intensifier micro channel plate limited spectral resolution

- **CCD - Charge Coupled Device** used to record Raman spectrum - 1986 when noise characteristics had been improved

Inherently lower noise device with no cross-talk

Good photosensitivity to violet to red

Two dimensional  $\Rightarrow$  can accommodate line image (line focus or line scan)  $\Rightarrow$  implications on spectrograph design and performance. In order to separate Raman signals from each point on the line, the astigmatism (line aberration) has to be eliminated. This can be achieved with cylindrical lens on input optics, by using PACH (patented aberration-correcting holographic) gratings, or by using a lens-based spectrograph.

# Impact of Availability of Solid State Multichannel Detectors

- **Size of linear device:** ca. 1000 25 $\mu$ m pixels ( 25mm)

- When introduced, most Raman systems were doubles:

The largest unvignetted field that could be recorded was 18mm

**Coverage** tended to be 100 to 200  $\text{cm}^{-1}$

- Total new design was developed to take advantage of the detectors

- **Spectrograph was sized** to produce ca. 1000  $\text{cm}^{-1}$  on the detector

- **Foremonochromator** was designed to “**filter**” the laser light - design was a subtractive double (“classical” triple)



# Raman Shift Calibration on Multichannel Detector

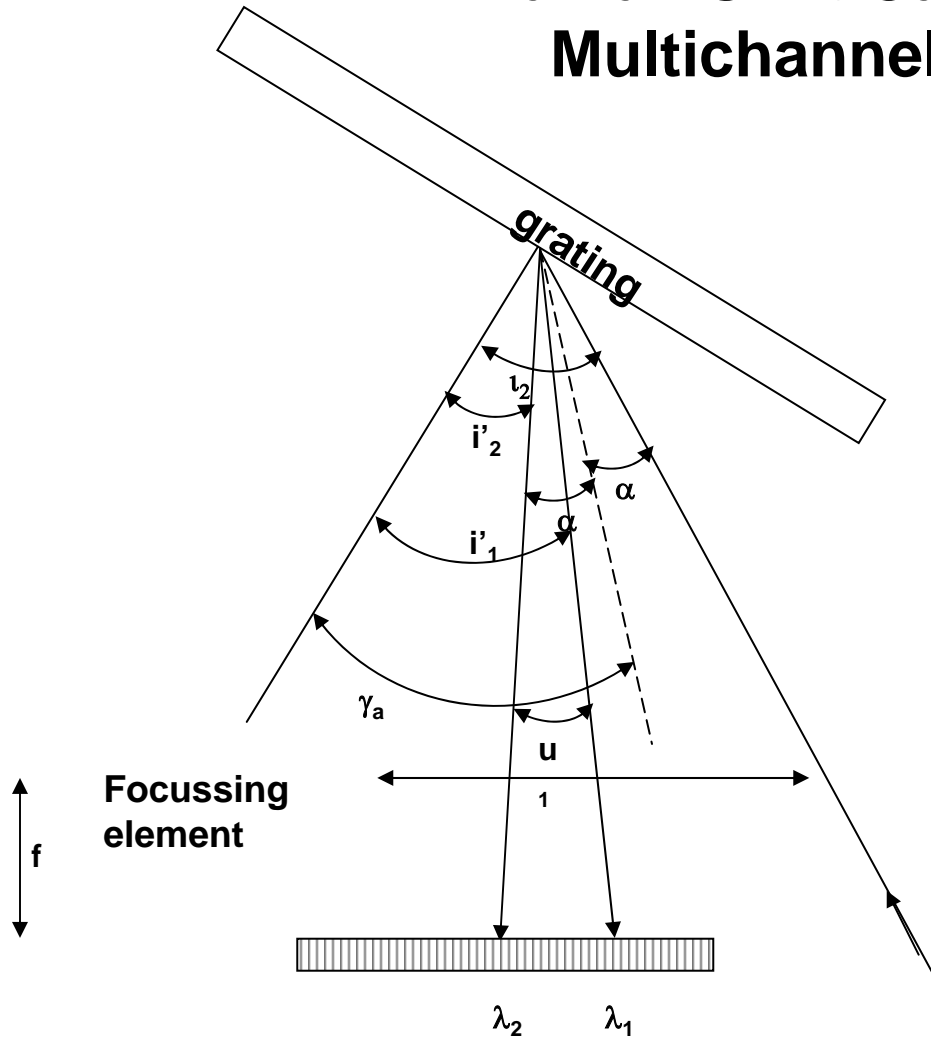

$$\sin \gamma_a = k\lambda / [2\cos \alpha]$$

$$\tan u_1 = d_1 / f = \tan (i_1' - i_2') = \tan [\arcsin \{k\lambda_1 - \sin(\gamma_a + \alpha)\} - (\gamma_a + \alpha)]$$

where  $d_1$  is the distance between pixels at  $\lambda_1$  and  $\lambda_2$



# DISPERSION, RESOLUTION, COVERAGE ON MULTICHANNEL DETECTOR

## THE ROLE OF FOCAL LENGTH, GROOVE DENSITY, $\lambda$ , AND PIXEL SIZE

- Grating groove density and Focal Length determine Dispersion
- Dispersion and Pixel Size determine  $\text{cm}^{-1}/\text{pixel}$
- Best resolution achievable is determined by the dispersion in 2 pixels, assuming that the incident slit is less than 2 pixels wide
- Experimental conditions can be optimized by
  - 1. exchanging gratings to
    - increase coverage, when large portion of spectrum is required (lower groove density grating), or
    - increase resolution when small shifts or closely spaced bands are of interest (higher groove density grating).
  - 2. and by changing laser wavelength, because the number of  $\text{cm}^{-1}$  spanned by  $1\text{\AA}$  depends on the wavelength itself

$4\text{cm}^{-1}/\text{\AA}$  at 500nm, but  $2\text{cm}^{-1}/\text{\AA}$  at 700nm



# Resolution vs Coverage

$\sim \lambda_{\text{ex}}$  and Grating Groove Density

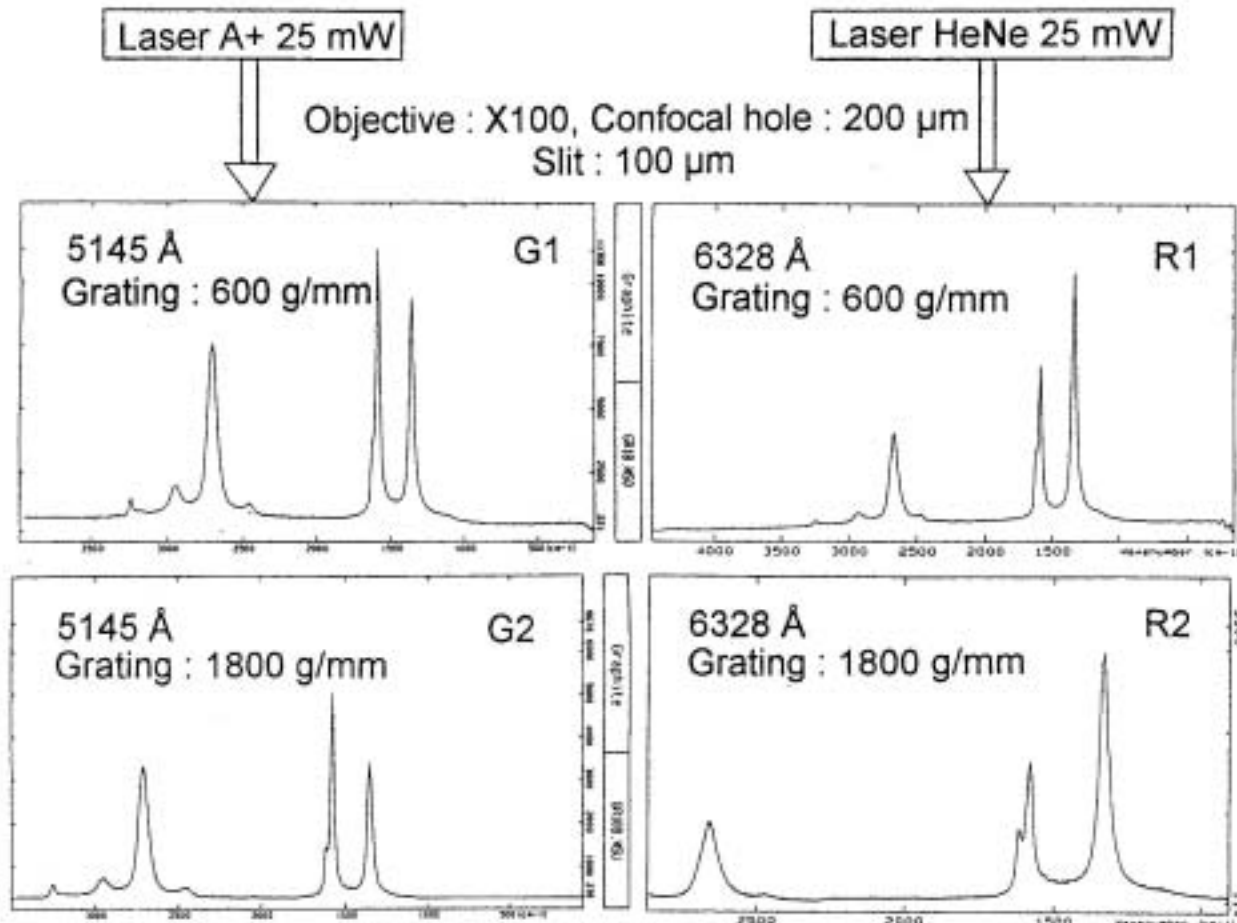

# Spectrograph Modifications for Multichannel Detectors

## 1. Initially required subtractive foremonochromator to eliminate laser line : Czerny-Turner

- Asymmetrize to flatten focal surface at least as large as 1”
- Correct for Astigmatism:
  - Triple Mate (1983 - Spex) - toroidal mirror reduces image in focal plane from >12mm to ~4mm
  - XY (1986 - Dilor) - cylindrical lens is placed in front of entrance slit
  - T64000 mk1- (1990 - Jobin Yvon) PACH (patented aberration correcting holographic) gratings - hologram is produced on optical table with optics identical to those of the spectrograph -> holographic profile which corrects for astigmatism in spectrograph

## 2. Lens-based spectrograph - esp. of interest after intro of holographic filters

- Use of camera lenses which by their nature correct quasi-perfectly coma, astigmatism, field curvature, etc. (previously used in prism spectrographs). However these lenses will never be achromatic over the UV to NIR range.
  - Microdil ~1983



# JY Triple Spectrographs

- Pre-mono to remove elastic (Rayleigh) scattering -

Double Subtractive for low frequency ( $< 5\text{cm}^{-1}$  in some systems!)

- Commercial instruments

OMARS89	1979	$(0.5)^2(400/300)$	multichannel and single channel
1877	1981	$(0.34\text{m})^2(0.5\text{m})$	8mm intermediate slit ->limited coverage
MICRODIL28	1981	$(0.5)^3$ (lenses in 3rd stage)	confocal laser scanning microscope patented lens-scanning system
S3000	1985	$(0.32)^2(0.64)$	
XY	1986	$(0.5\text{m})^3$ or $(0.8\text{m})^3$	modular, Additive mode, SAS, csc drive
T64000mk1	1988	$(0.64)^2(0.64)$	Additive mode, SAS, sine drive



# Triple Spectrograph

“Classical” or Subtractive Mode

Concept shown

Optical Diagram shown

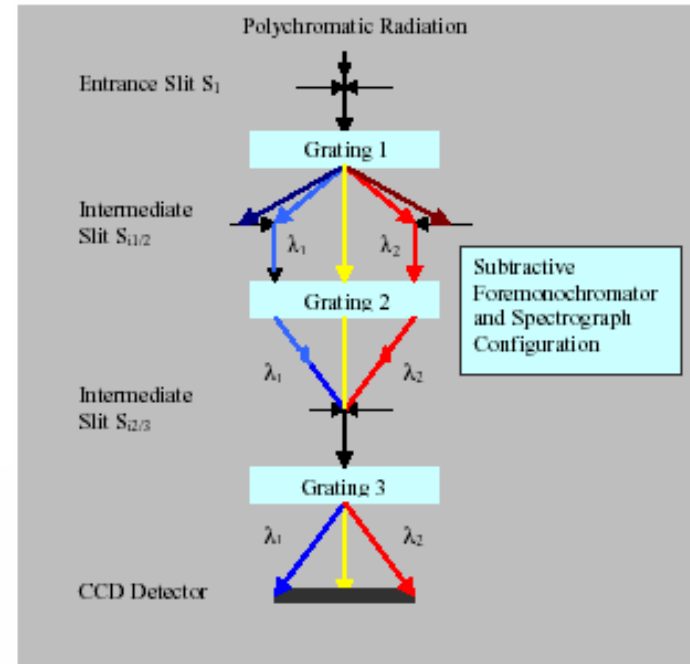
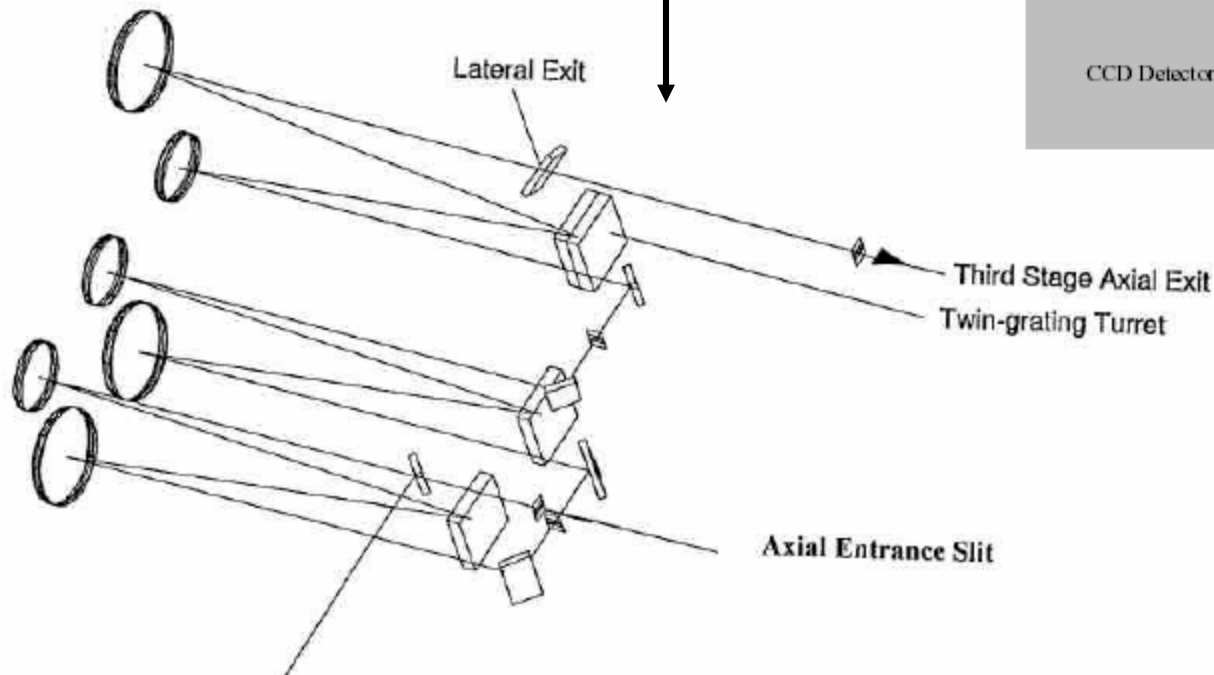

# Triple Spectrograph

Additive Mode

Concept shown



Optical Diagram shown

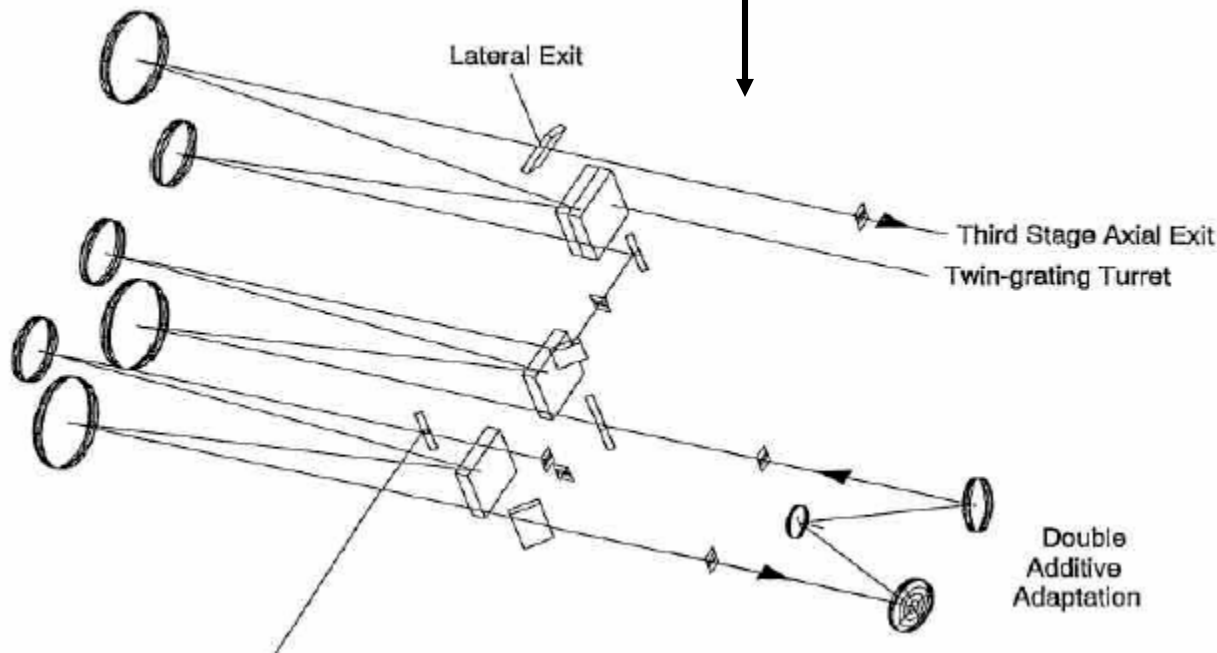
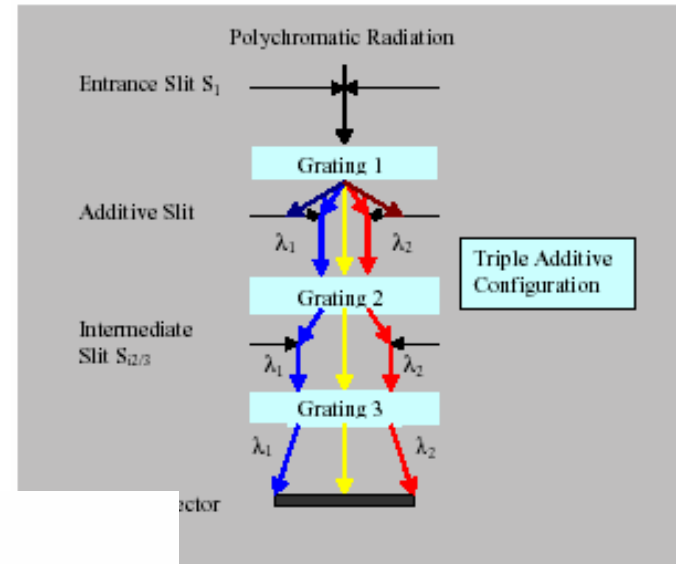

## Characteristics

Triple resolution

1/3 signal/pixel

Less stray light rejection w CCD



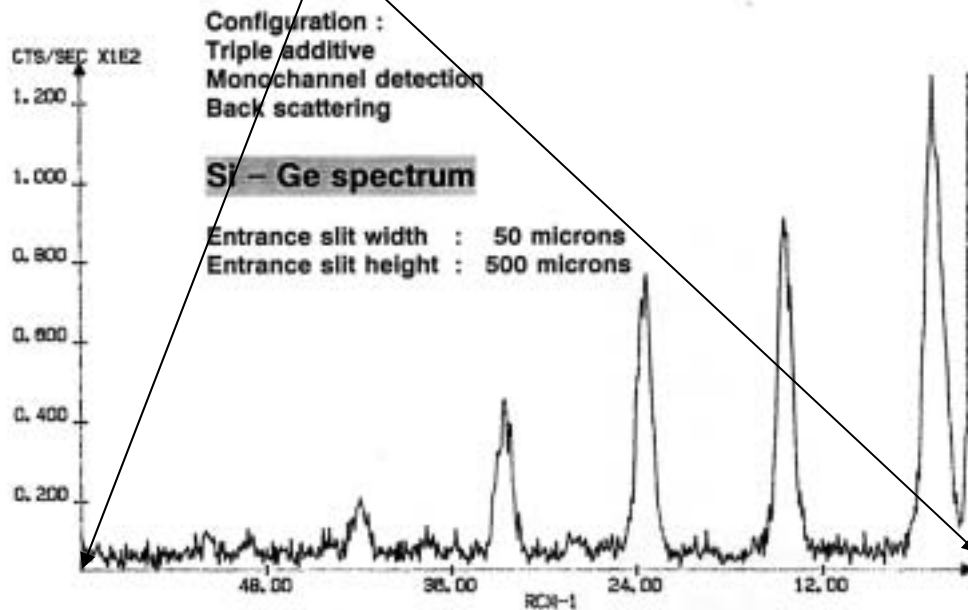
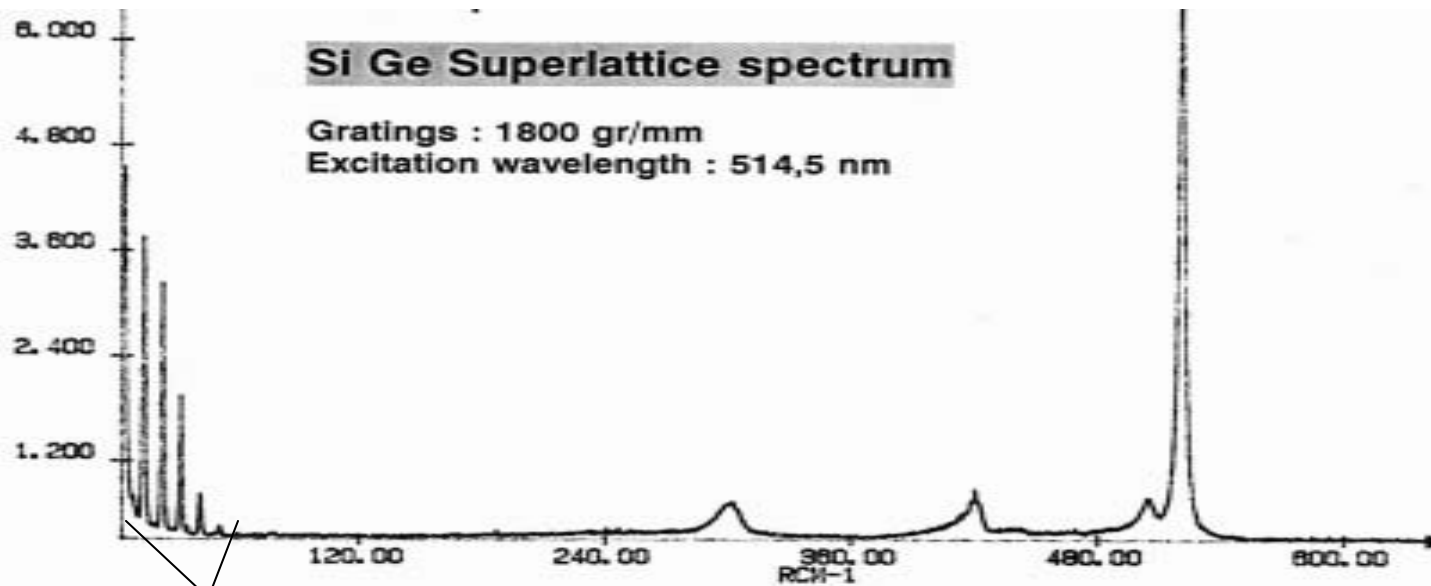

**Classical Triple + CCD (top)**  
**vs.**  
**Triple Additive + PMT (bottom)**





# Comparative Spectra of Silicon

## Acquired in Additive vs. Subtractive Modes w CCD

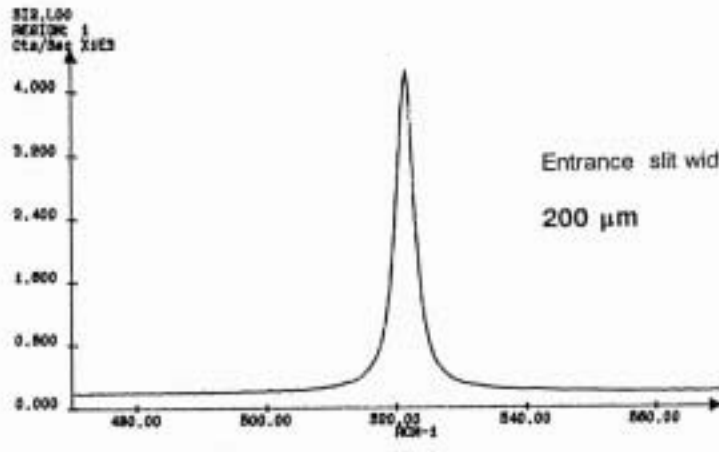
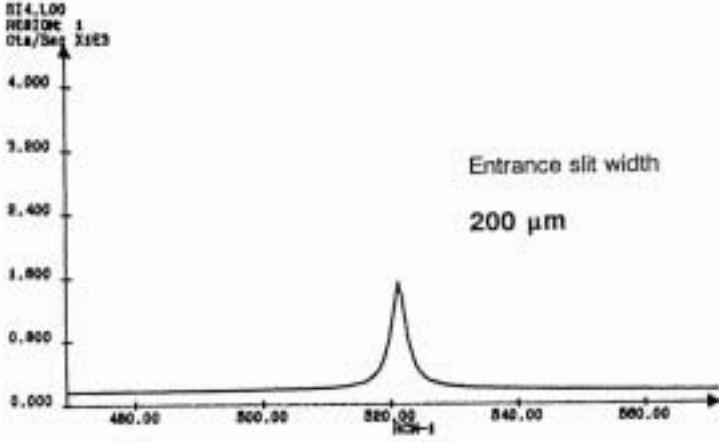
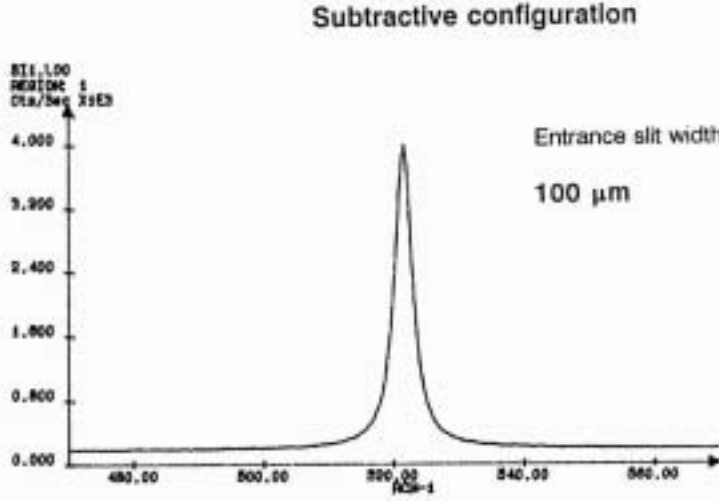
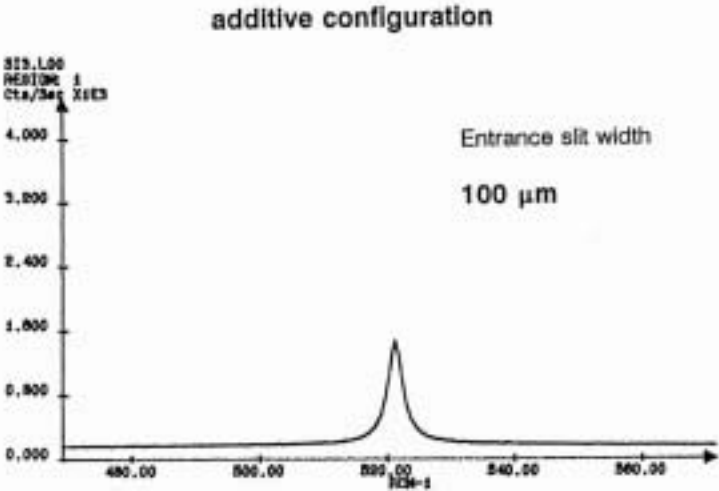

# Comparative Spectra of Silicon

## Acquired in Additive vs. Subtractive Modes w PMT

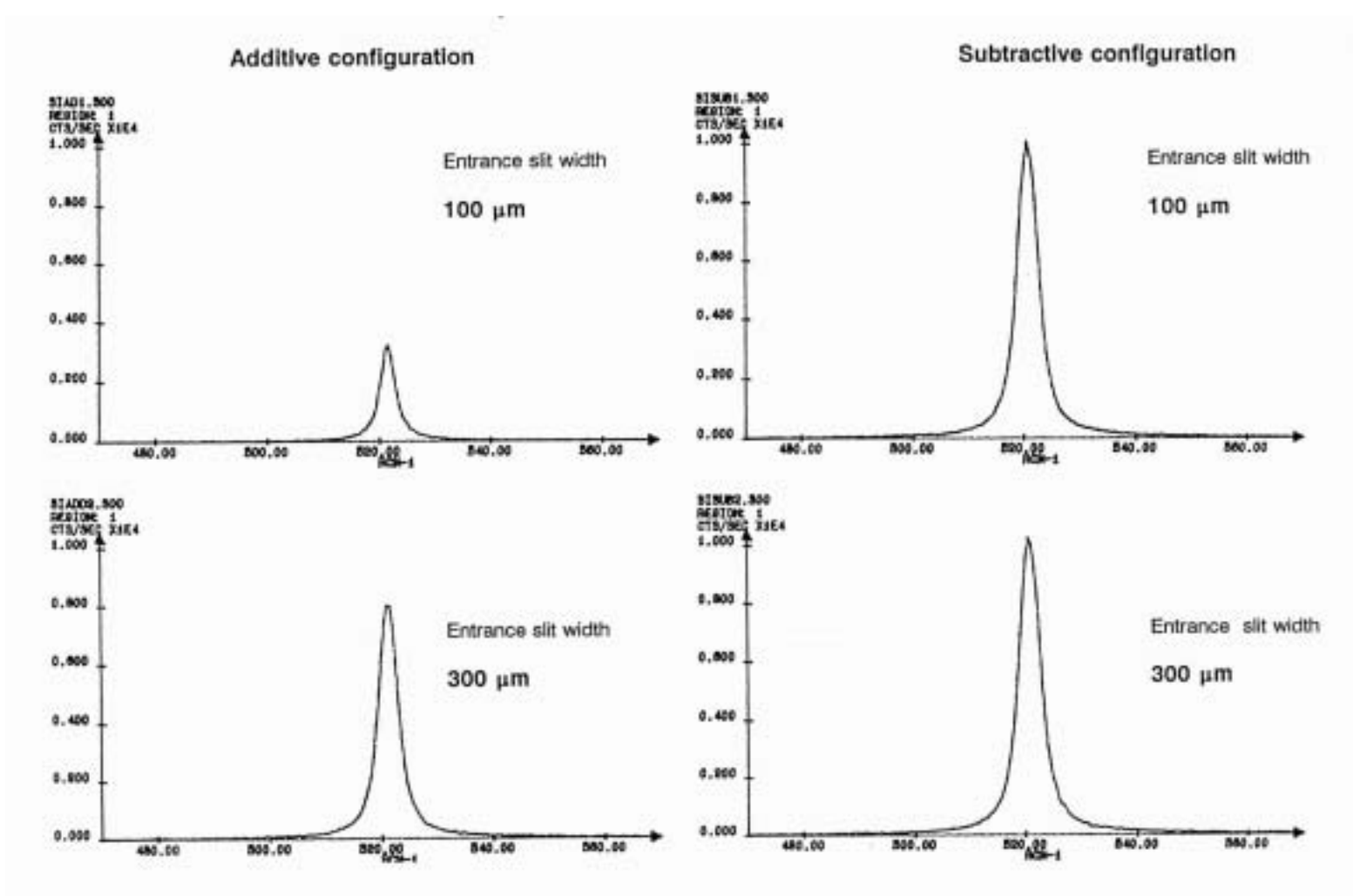

# Raman Microscopy Was a microprobe possible?

- In 1966 Delhaye and Migeon argued that a laser beam could be tightly focussed at a sample, and the Raman light efficiently collected and transferred to a spectrometer, without losses.
- Calculations showed that increase in irradiance more than compensated for decrease in size of irradiated volume.

M. Delhaye and M. Migeon, Effet Raman – Calcul du gain apporte par un dispositif optique de concentration du faisceau laser pour l'étude de l'effet Raman, C.R. Acad. Sc. Paris, t.262, 702-705 (7 mars 1966)

M. Delhaye and M. Migeon, Effet Raman – Interet de la concentration d'un faisceau laser pour l'excitation de l'effet Raman, C.R. Acad. Sc. Paris, t.262, 1513-1516 (13 juin, 1966)

Tomas Hirschfeld - promoted the idea, based on computations, that sample dimension is not as important as the optical scheme for probing a femto liter sample. His ideas appeared as an abstract Hirschfeld J Opt. Soc. V63 1973



# Original Concepts of Raman Microscope

Initial goal was to produce a picture of the sample through its Raman signal in order to promote the development to the Raman community.

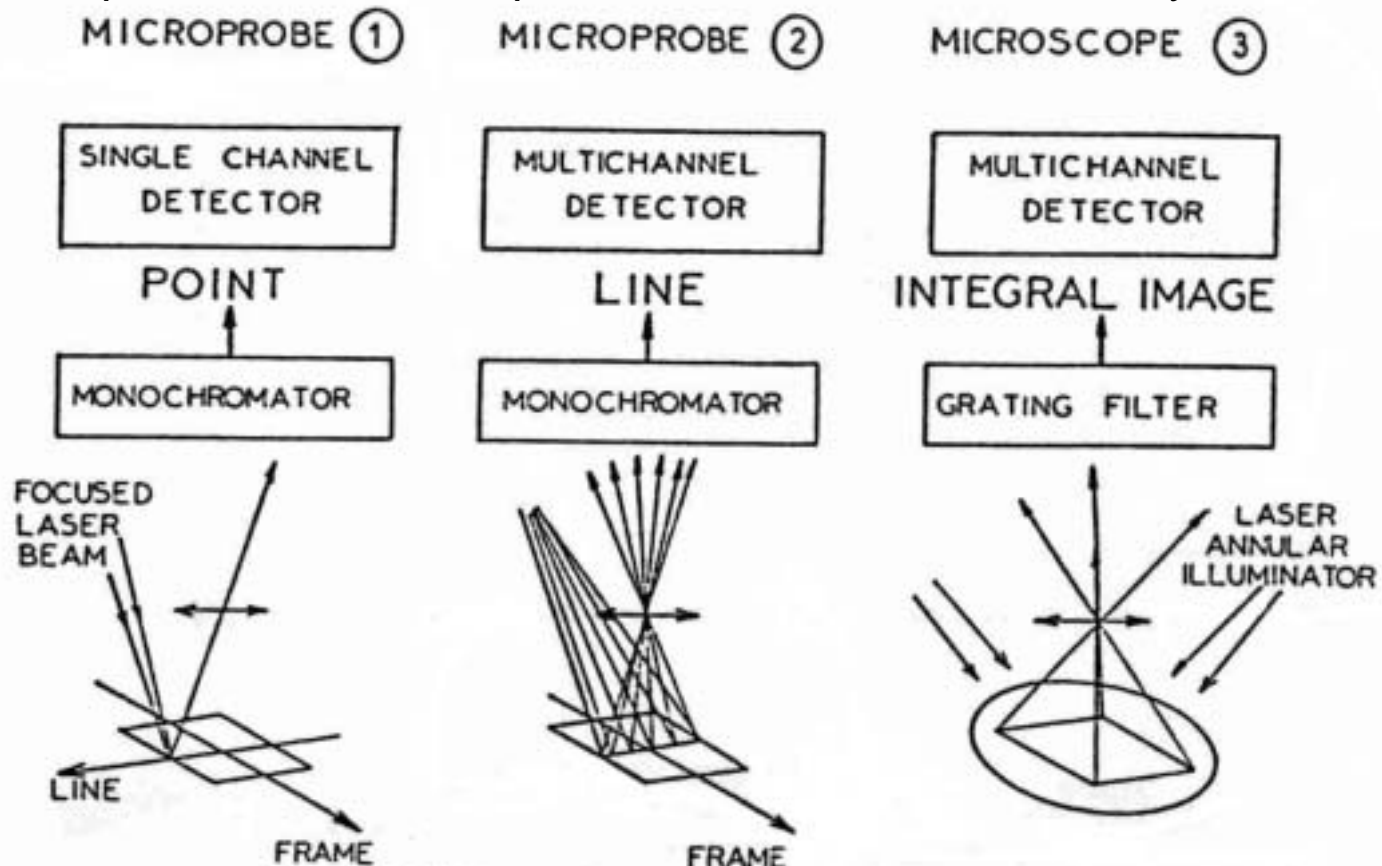

Laser spot scanned across sample - image reconstructed from PMT<sub>signal</sub>

SCANNING

Laser spot scanned along line and imaged thru stigmatic mono onto multichannel detector

NO SCANNING

Global laser illumination - sample imaged onto detector thru  $\lambda$ -selection filter

Delhaye and Dhamelincourt, J Raman Spectros. 3, 35-43 (1979)



# MOLE™ (Molecular Optics Laser Examiner)

## First Commercial Instrument - ca. 1974

- Double spectrometer/spectrograph
- Imaging implemented with global illumination and sample re-imaged onto gratings and then detector
- Many early applications were in Geosciences and contaminant analysis in industrial materials.
- Lack of sensitivity made Raman mapping/imaging impractical due to high background levels; problems eventually overcome with confocal coupling and data treatments including multivariate algorithms.



**Prototype -  
L'Universite des  
Sciences et  
Techniques de Lille  
France**



# Three Modes of Operation of MOLE™

Raman Imaging (lower left), Spectrograph (upper right) and Monochromator (lower right)

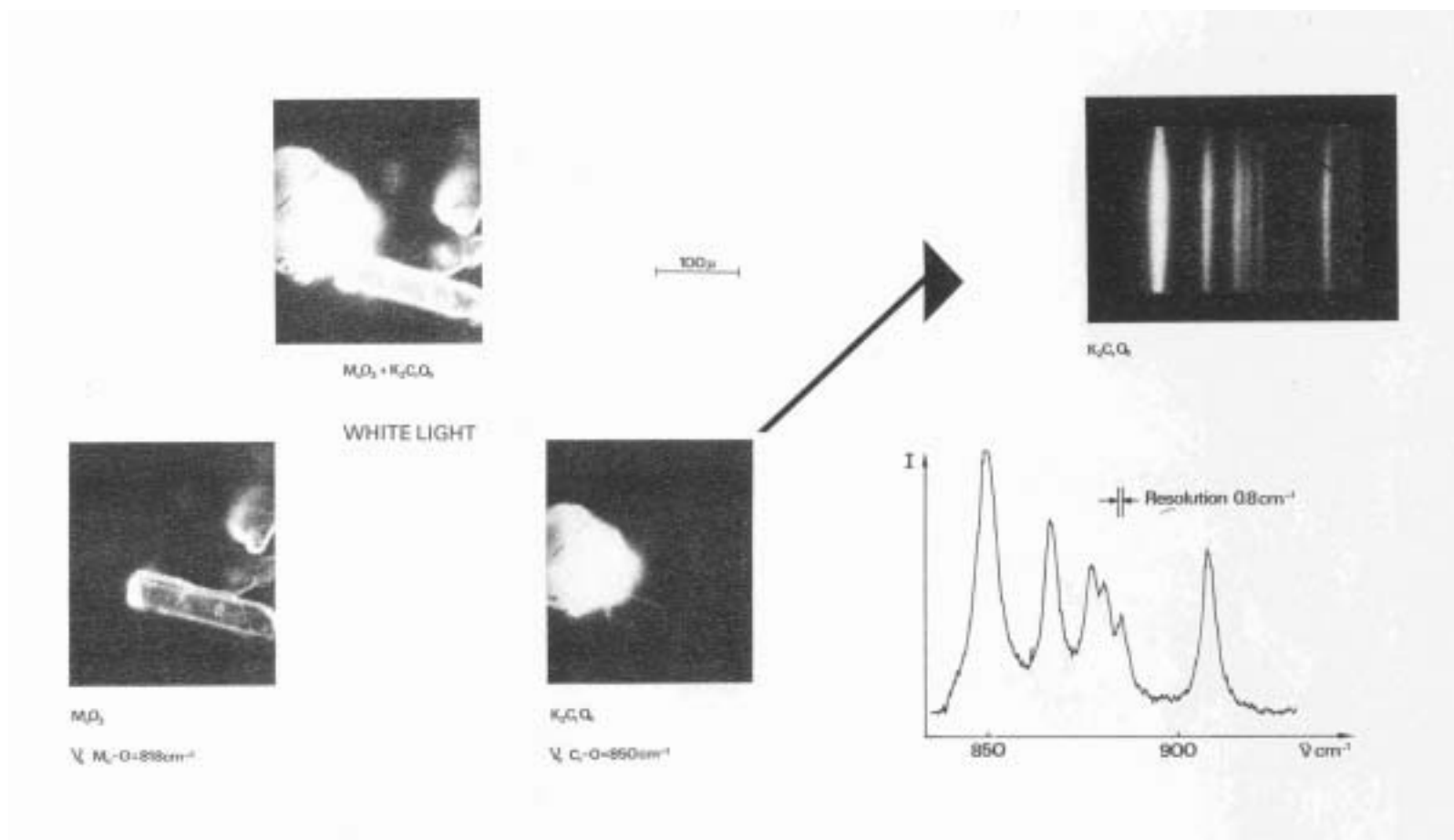



# Raman Sampling Volume ~ Year

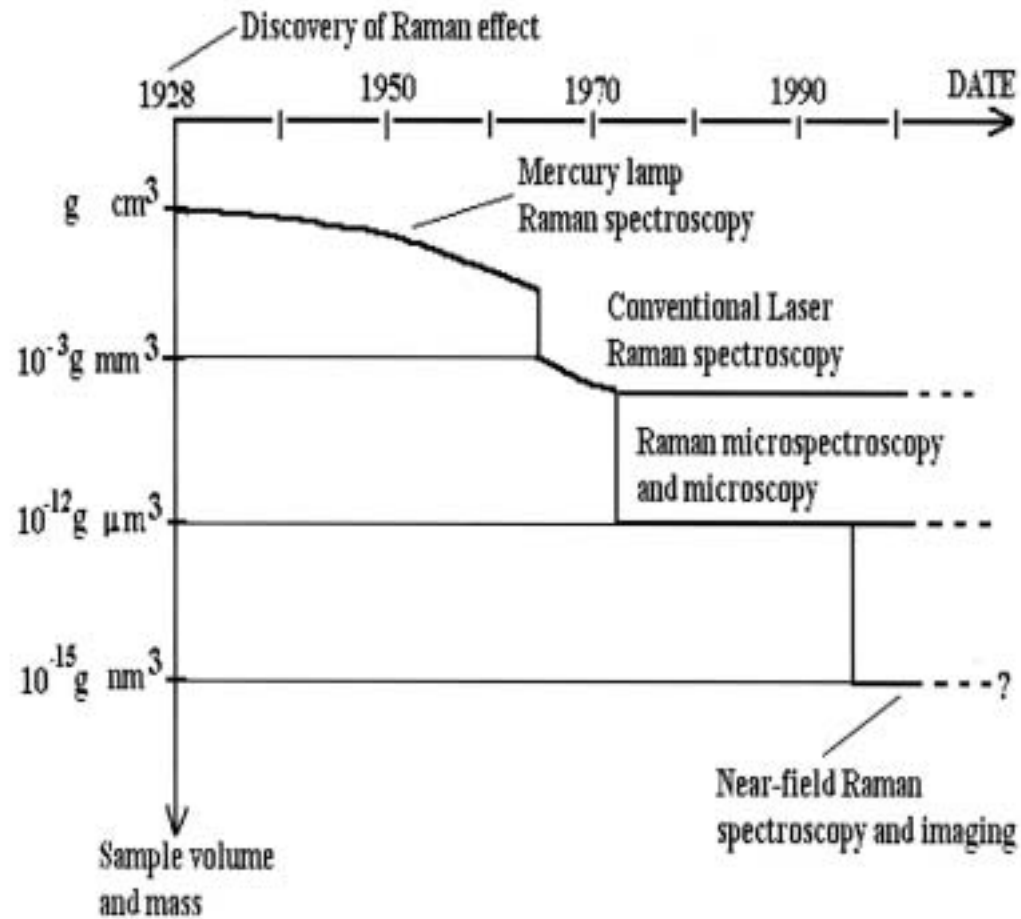

From talk of Delhaye and Dhamelincourt at the meeting of the Microbeam Society



# Solid Inclusion in Mineral

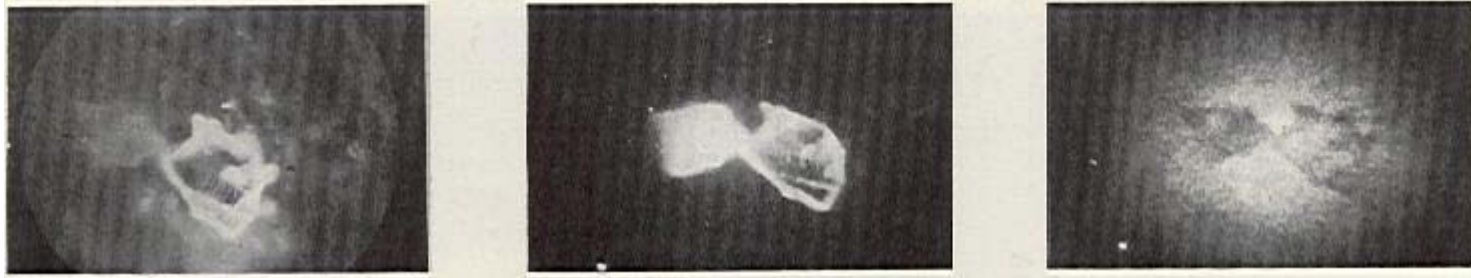

White light Illumination

Sulfur line at 473 cm<sup>-1</sup>

SrSO<sub>4</sub> line at 1000 cm<sup>-1</sup>

These images were recorded on the MOLE™ using Global Imaging and published in product literature in 1976.



## Analysis of Contents of Fluid Inclusion (bottom) and Map of Calcite Phase (top)



FIG. 9 : Image de l'inclusion fluide en lumière blanche.

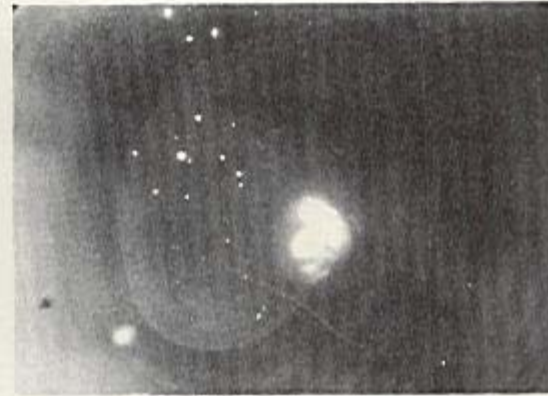
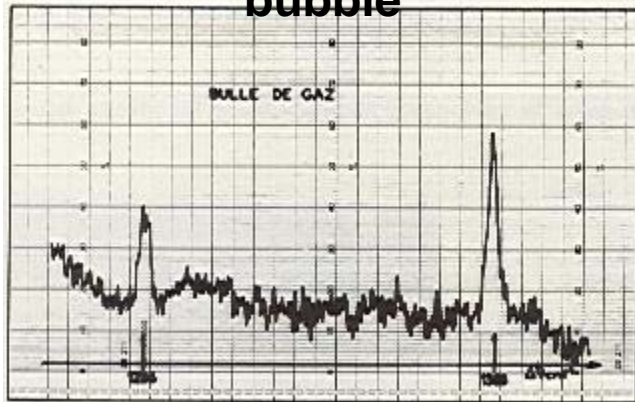
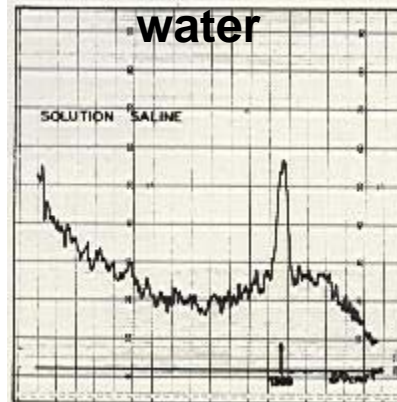

FIG. 10 : Image de l'inclusion fluide dans la raie 1088cm⁻¹.

**CO<sub>2</sub> in  
bubble**



**CO<sub>2</sub>  
dissolved in  
water**



**Calcite (CaCO<sub>3</sub>) in  
water**

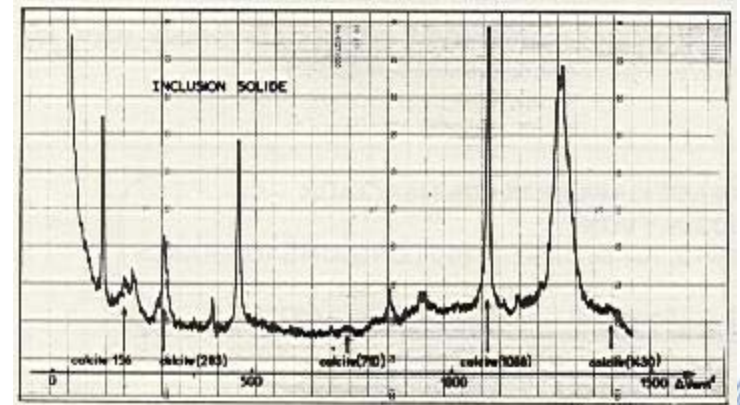

HORIBA

## Advantages of the Microscope for Raman Sampling

- **Laser Focus:** high na enables tight focusing ( $\Rightarrow < 1\mu\text{m}$ )  $\Rightarrow$  microprobe
- **Raman Collection:** high na enables collecting almost  $2\pi$  steradians
- **Image Transfer:** correct optical coupling with spectrograph  $\Rightarrow$  all Raman light can be transmitted by  $\sim 100\mu\text{m}$  entrance slit  $\Rightarrow$  high throughput



## Laser Focus by Microscope Objective

The availability of high na objectives enable the small focus

$$\omega_0 \cong \lambda/na \Rightarrow 0.5 - 1\mu\text{m}$$

$$na = n \sin\Theta$$

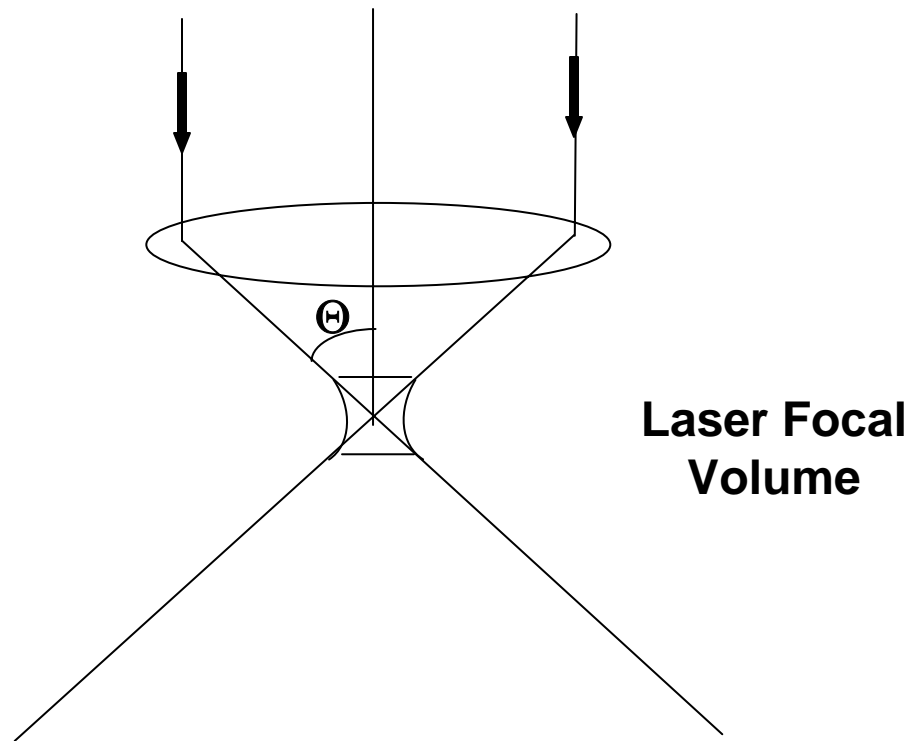

# Microscope Objectives

For High  
Numerical  
Aperture

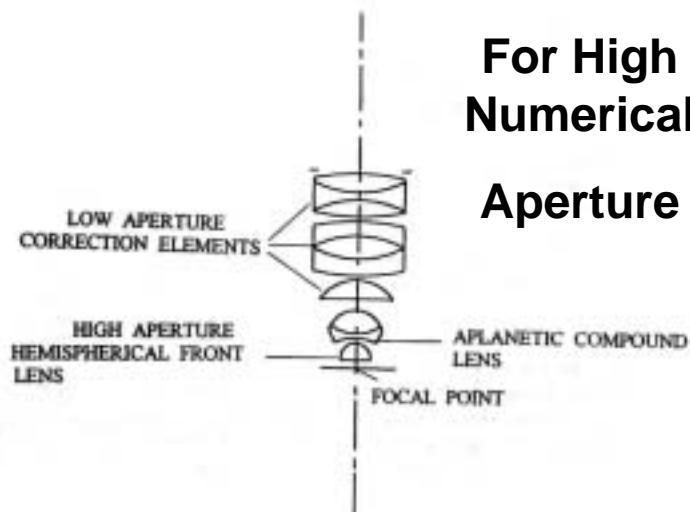

Numerical Aperture determines

1. Spot size
2. Collection Efficiency
3. Spatial Resolution - axial and lateral

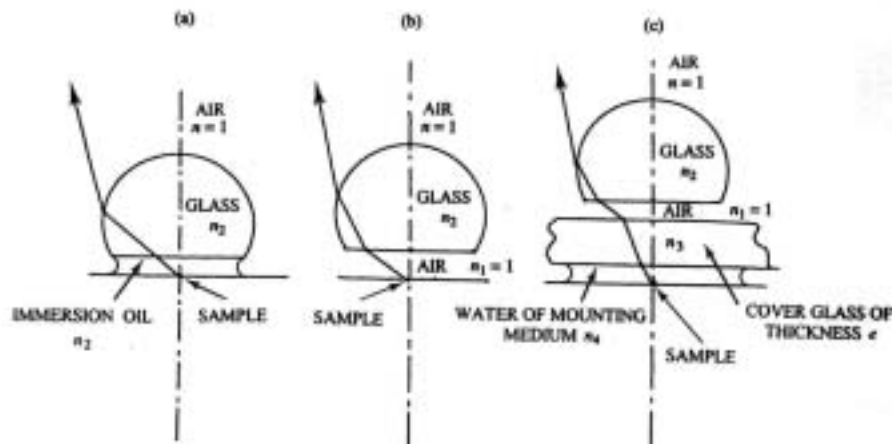

Immersion Optics for Increasing Numerical Aperture and for examining deep inside materials ( $>20\mu\text{m}$ ) with index  $n>1$  and minimizing loss of confocality due to spherical aberrations in sample

Figures 11 and 12 in Chap.3 Instrumentation by M Delhaye, J Barbaillat, J. Aubard, M Bridoux, and E DaSilva in Raman Microscopy, ed. G. Turrell and J. Corset (Academic Press, London 1996)





## Comparison between

Numerical Aperture:  $NA = n \sin \theta$

Photographic Aperture:  $f/\#$

Collection Efficiency ~ Solid Angle:  $\Omega$

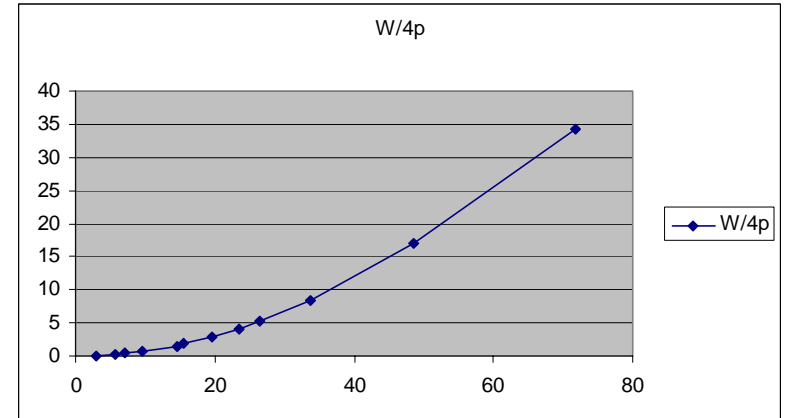
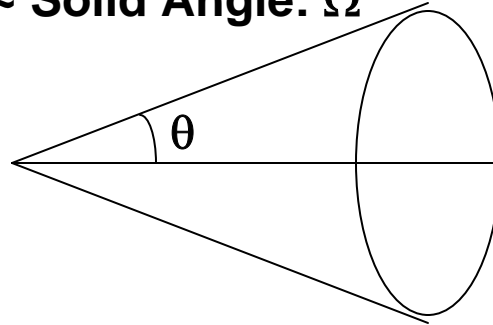

Collection Efficiency  $\Omega$  as a function of Cone Angle  $\theta$

	OPTIC	NA = $n \sin \theta$			$\theta$	$\Omega/4\pi$
		n=1	n=1.33	n=1.5		
	f/10	0.0499	0.066	0.74	2.862	0.06
	f/5	0.099	0.131	0.148	5.71	0.25
	f/4	0.124	0.165	0.186	7.125	0.38
	f/3	0.164	0.218	0.246	9.462	0.68
10x	f/1.93	0.25	0.332	0.375	14.477	1.5
<b>M Chamber</b>	<b>f/1.8</b>	<b>0.267</b>	<b>0.355</b>	<b>0.4</b>	<b>15.485</b>	<b>1.8</b>
M Chamber2	f/1.4	0.336	0.447	0.504	19.633	2.9
20x ULWD	f/1.14	0.4	0.532	0.6	23.578	4.1
	f/1	0.44	0.594	0.67	26.551	5.2
50xULWD	f/0.75	0.554	0.737	0.831	33.69	8.4
50x	f/0.44	0.75	0.997	1.125	48.59	16.9
<b>100x</b>	<b>f/0.164</b>	<b>0.95</b>	<b>1.263</b>	<b>1.425</b>	<b>71.8</b>	<b>34.3</b>



# Coupling Microscope to Spectrometer

## Principle

- sample is imaged at slit, and sometimes at intermediate plane for redundant confocal aperture
- objective of pupil is imaged on grating

## Implementation

- beam splitter separates incident and collected rays without sacrificing na at sample
- spatial filter at intermediate image plane defines scattering volume  $\Rightarrow$  confocal definition

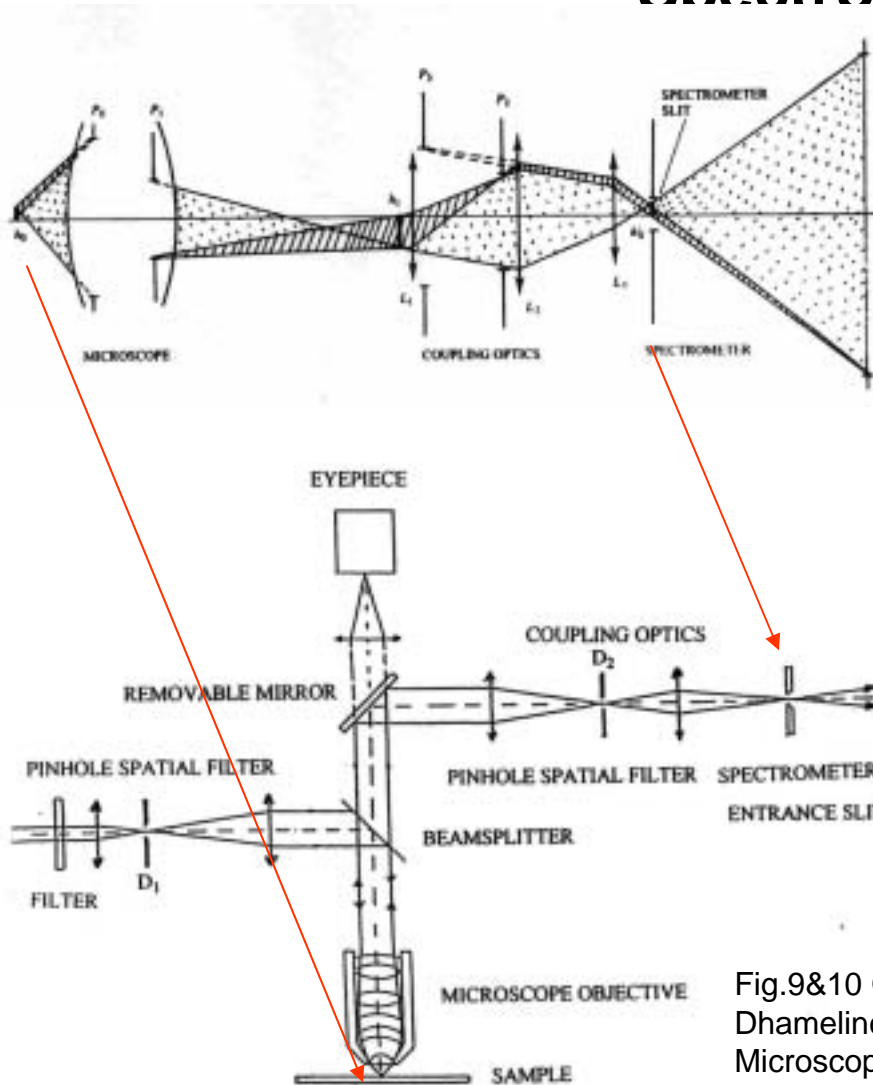

Fig.9&10 GTurrell, M Delhaye, and P Dhamelincourt, Characteristics of Raman Microscopy, in Raman Microscopy, ed G. Turrell (Academic Press, London, 1996)



# Confocality

Confocal apertures define the volume from which signal is collected. This volume is defined independently of the laser spot.

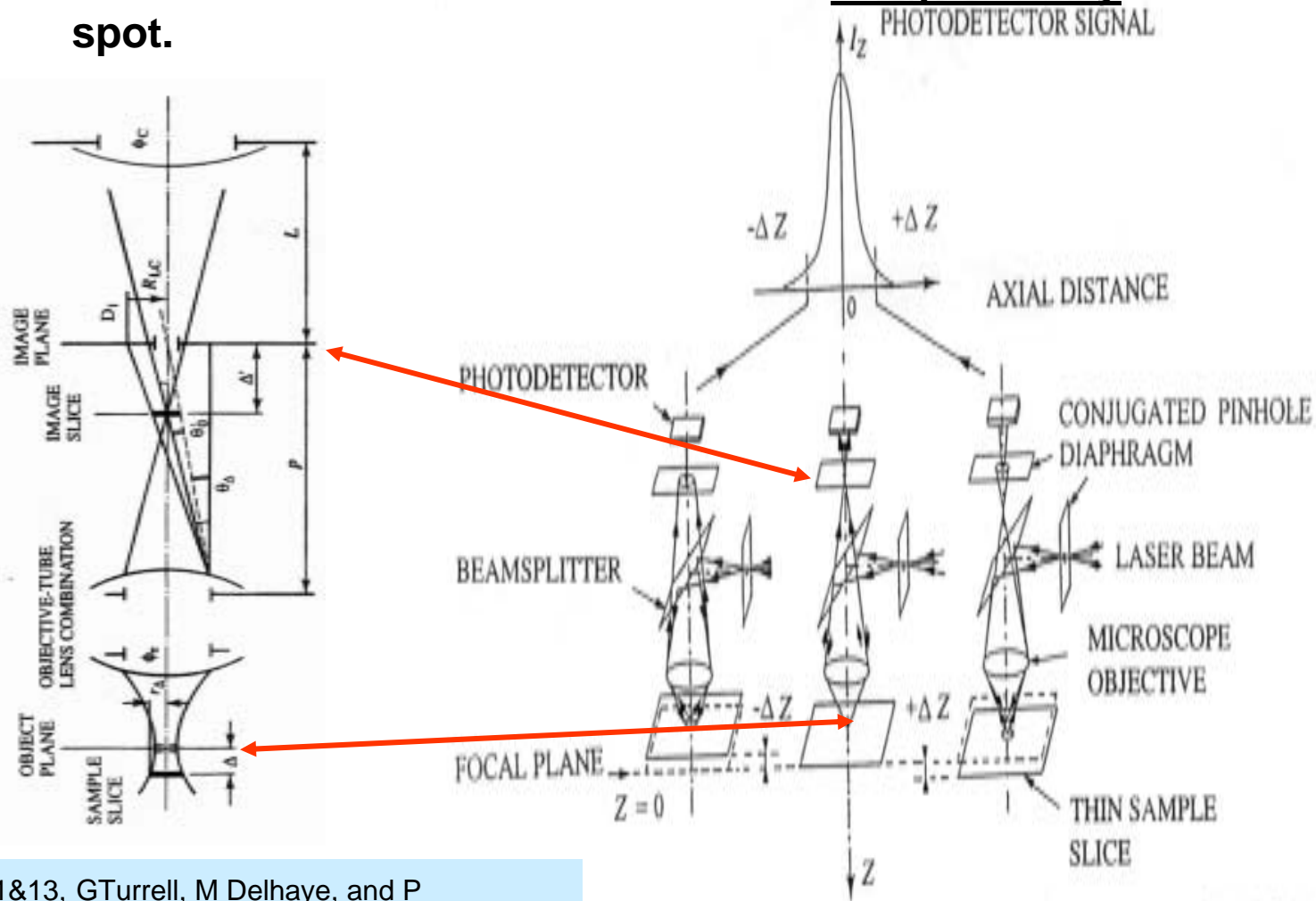
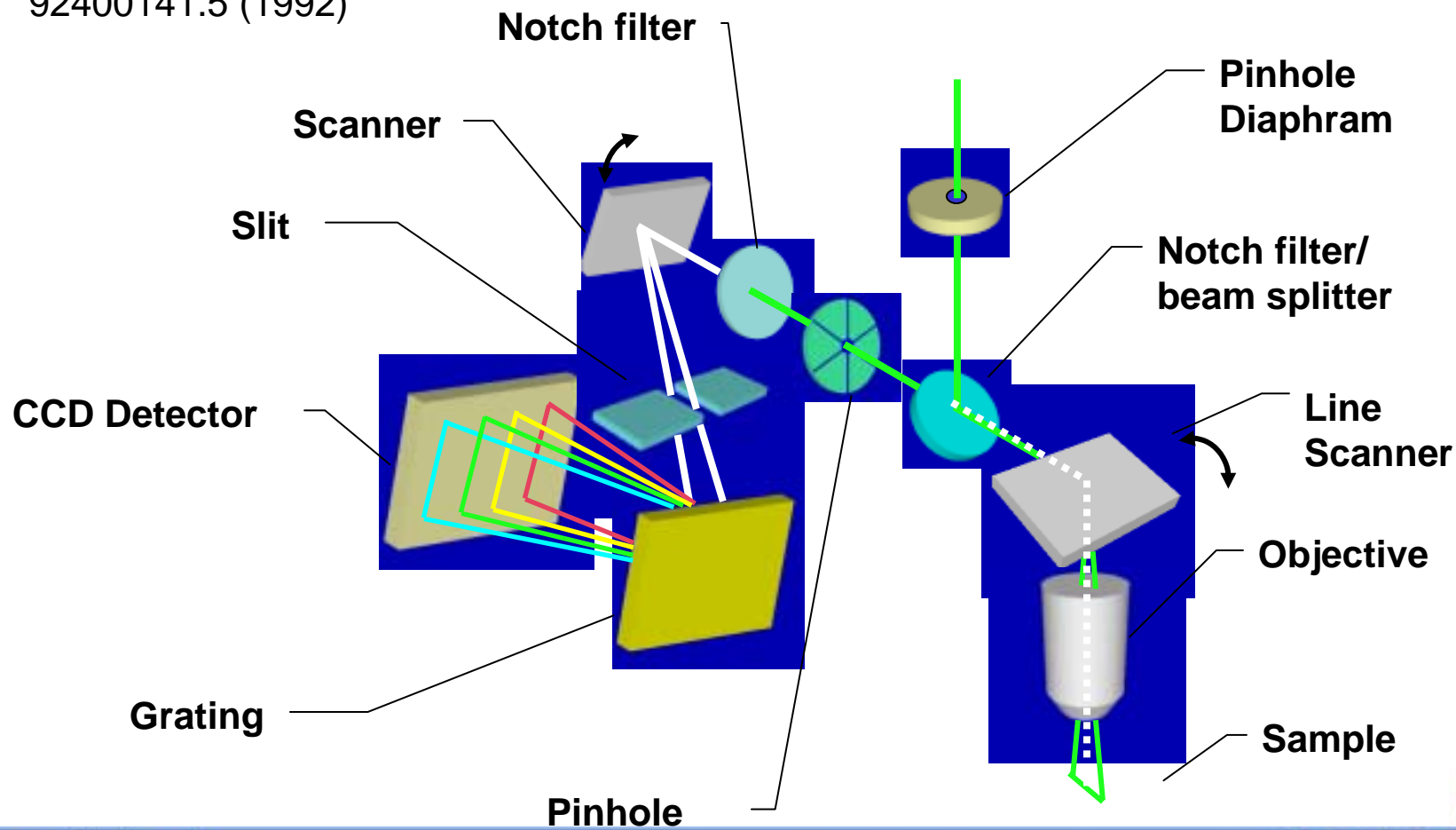

Fig.11&13, GTurrell, M Delhayé, and P Dhamelincourt, Characteristics of Raman Microscopy, in Raman Microscopy, ed G. Turrell (Academic Press, London, 1996)

# Confocal Line Scanning

Patented unique method to scan laser through objective to avoid aberrations and maintain diffraction-limited spot. Then the spectrum of each spot on sample is displayed on a different row of the CCD, **assuming that the spectrograph is stigmatic.** European patent # 92400141.5 (1992)



# Confocal Images from Pathology Samples (explants), courtesy of Jose Centeno, AFIP

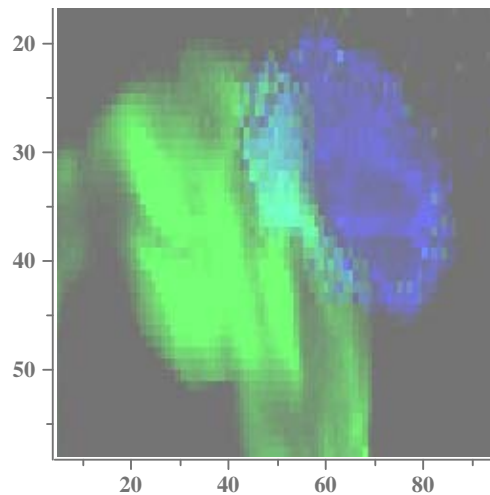
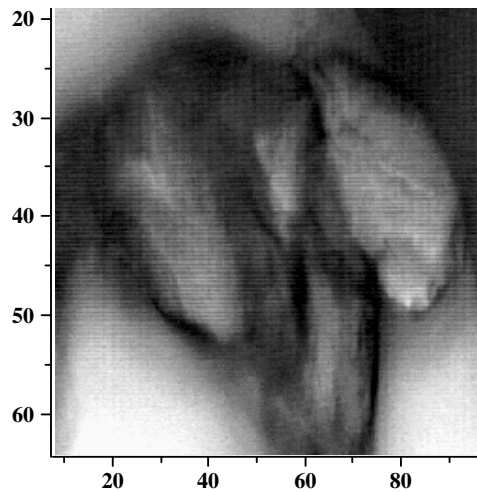
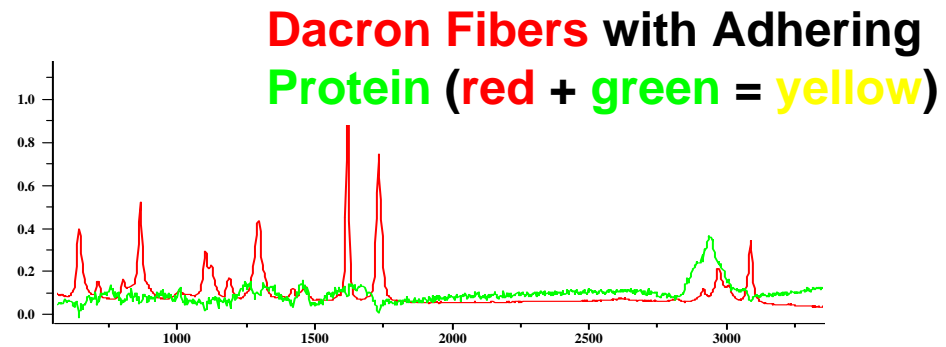
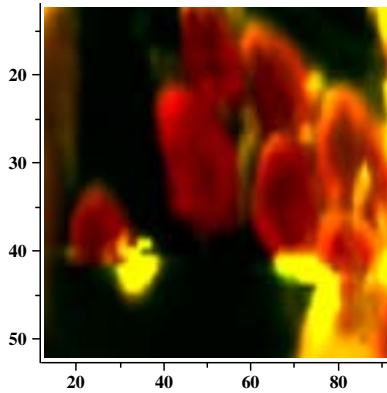

## P-silicone and P-urethane

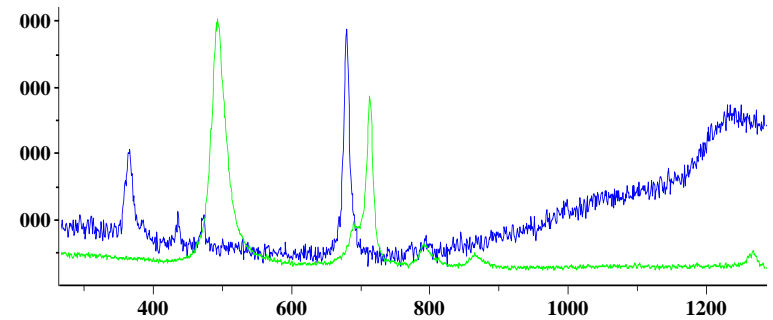

# Holographic Filters

Initially reported in **1990** by **Carrabba**<sup>1</sup> as an effective means to suppress elastically scattered light so that any size monochromator could be used to collect Raman spectrum. Depending on the type of filter produced, and how it is mounted, lines as close as  $30\text{ cm}^{-1}$  from the laser line can be observed.

Historical curiosity: there was a **1948** publication, in which it was shown that it was possible to make filters based on technology from the beginning of the last century<sup>3</sup>, which could reflect a selected wavelength and transmit all others!. “En particulier, Mr. Kastler avait eu l’idée d’utiliser les plaques Lippmann, dans l’obtention des spectres Raman, pour affaiblir la raie excitatrice si gênante dans l’étude des raies de basses fréquences.” **“In particular, Mr. Kastler has had the idea of utilizing the Lippman plates in order to obtain Raman spectra, by reducing the exciting beam which interferes in the low frequency region.”**

1. Carrabba, et.al., The Utilization of a holographic Bragg diffraction filter for Rayleigh line rejection in Raman spectroscopy, App. Spectrosc. **44**, 1558-1561 (1990)
2. Jean-Loup Delcroix, Utilisation des Plaques Lippmann Comme Filtres, Revue d’Optique t.27, no.8-9, 493-509 (1948)
3. Gabriel Jonas Lippman, Nobel Prize, 1908, “for his method of reproducing colors photographically based on the phenomenon of interference”





## Evolution of Microspectroscopy

**1974 Fourth International Conference on Raman Spectroscopy, Brunswick, ME,  
- reports of first prototypes of 1973 based on doubles with PMT's**

#5.1.10 GJ Rosasco and E Etz, Investigation of the Raman Spectra of Individual Micron Sized  
Particles

#5.B M Delhaye and P Dhamelincourt, Laser Raman Microprobe and Microscope

**1980's Triple spectrographs with microscopes and IPDA's**

**1989 Raman microscopes with CCD multichannel detector**

**1991 Notch filters used in injection/rejection of laser**

**Rebirth of widefield, direct (global) imaging due to use of optical tunable  
filters (AOTF, LCTF, Interference)**

**Introduction of confocal microscopy for point analysis and imaging  
(point and linescan) providing improved**

- depth resolution
- contrast of Raman images/maps
- rejection of fluorescence

**1992 European patent for confocal line-scanning**

# BENCHTOP RAMAN SYSTEMS

## Enabling Technologies for Practical Commercial Products or,

### How we Got to Where we are Today

- **Holographic Notch Filter** - to remove laser line and consequently enable construction of smaller, much more sensitive instruments
- **Air-cooled Lasers** - to lower utility and space requirements
- **Multichannel detectors**, esp. CCD's - for high sensitivity and rapid spectral acquisition
- **High power desk top computers** for full acquisition control and sophisticated spectral analysis

Guesstimate for increase in sensitivity and ease of use: 2 to 3 orders of magnitude

[FTIRaman and more complete discussions of CCD's and holographic technologies will be discussed separately in later talks.]



# Applications of the Microprobe

- Pharmaceuticals
- Polymers
- Bioclinical sciences
- Forensic Science
- Cultural Heritage
- Chemical/Molecular Structure
- Ceramics
- Semiconductors
- Corrosion
- Geosciences
- Catalysts

## Markets

Analytical  
Educational

Research

Process

QC

Drug Development (HTS)



## Current and Future Developments

**UV** - for higher spatial resolution and RR - can UV excitation be used routinely without inducing photochemistry, especially in organic solids?

**NSOM** - is there really sensitivity for near-field Raman excitation and/or collection?

**Electron Microscopy** - how can Raman optics be introduced into the vacuum for effective Raman excitation?



# UV to NIR Excitation

Back to mirror optics to maintain focus over spectral range

Be aware of effects of focal length and  $\lambda$  on spectral resolution

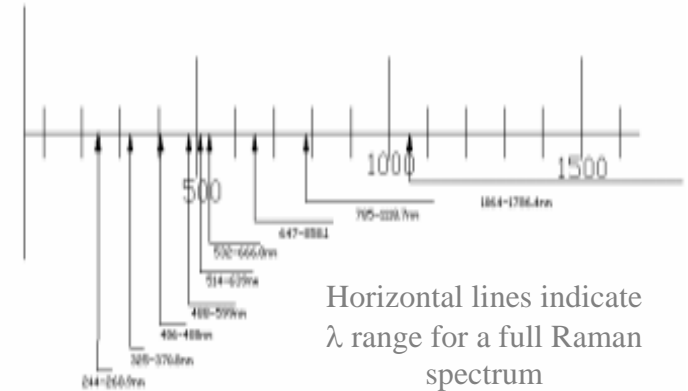
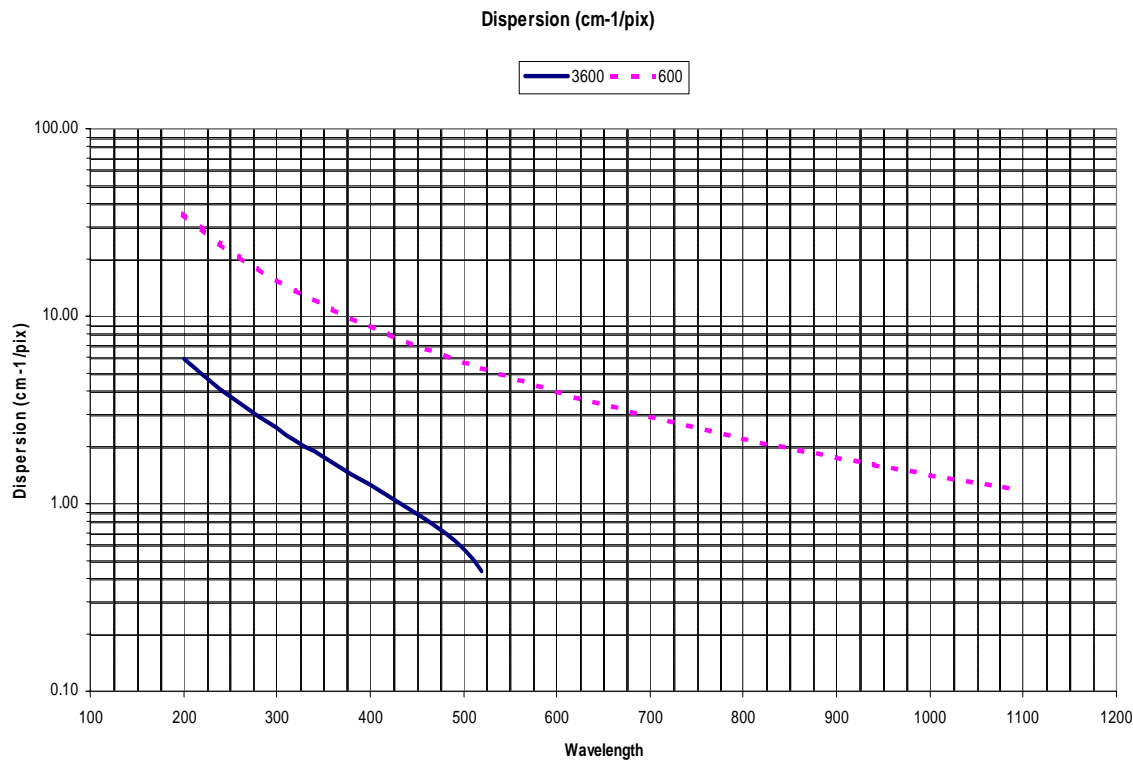

Dispersion cm<sup>-1</sup>/26 $\mu$ m pixel on 300 mm spectrograph as a function of wavelength and groove density



## 1987 Suggestion for Introduction of Raman Optics into Electron Microprobe

M. Truchet and M. Delhaye, Transmission Electron Microscope with Castaing's Electron X-ray and Laser Raman Probes for Simultaneous Elemental and Molecular Analysis at Submicrometric Scale, in *Microbeam Analysis - 1987*, ed. RH Geiss (San Francisco Press)

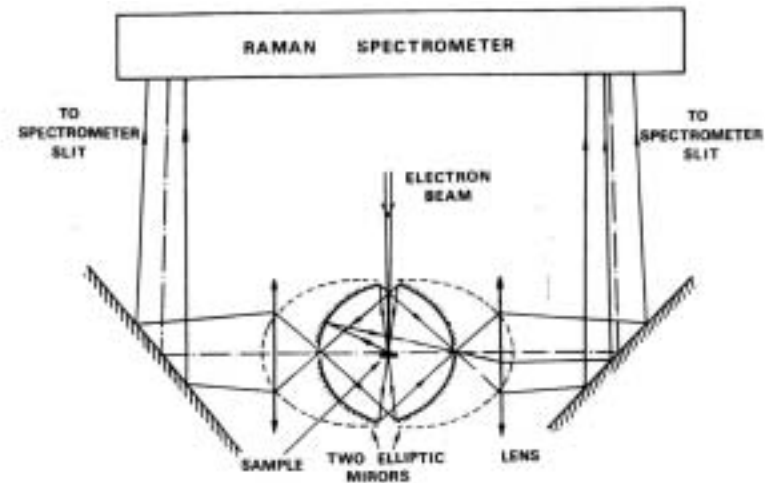
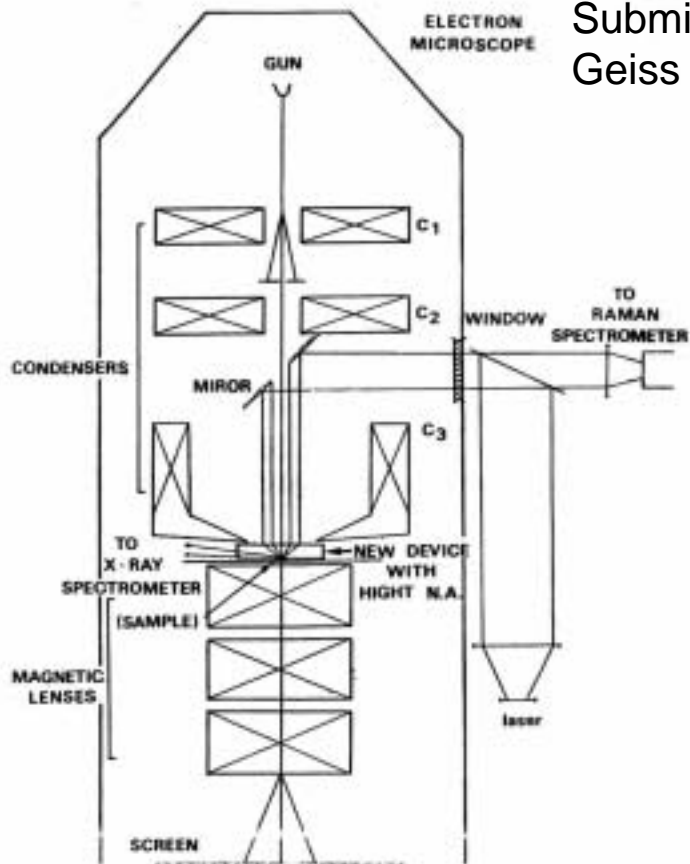



# Thanks

Dr. Michael Carrabba

Prof. Paul Dhamelincourt

Prof. John Ferrarro

Dr. Michel Leclercq

Joel Oswald

Prof. Anant Ramdas - Raman's last student

Hans Juergen Reich

Dr. Bernard Roussel

Steve Slutter

Dr. Alfons Weber

Dr. Andrew Whitley

