

## Evolution of the IBDM Structural Latch Development into a Generic Simplified Design

K. De Vriendt\*, H. Dittmer\*, D. Vrancken\*, P. Urmston\*\* and O. Gracia\*\*

### Abstract

This paper presents the evolution in the development of the structural latch for the International Berthing Docking Mechanism (IBDM, see Figure 1). It reports on the lessons learned since completion of the test program on the engineering development unit of the first generation latching system in 2007. The initial latch design has been through a second generation concept in 2008, and now evolved into a third generation of this mechanism. Functional and structural testing on the latest latch hardware has recently been completed with good results.

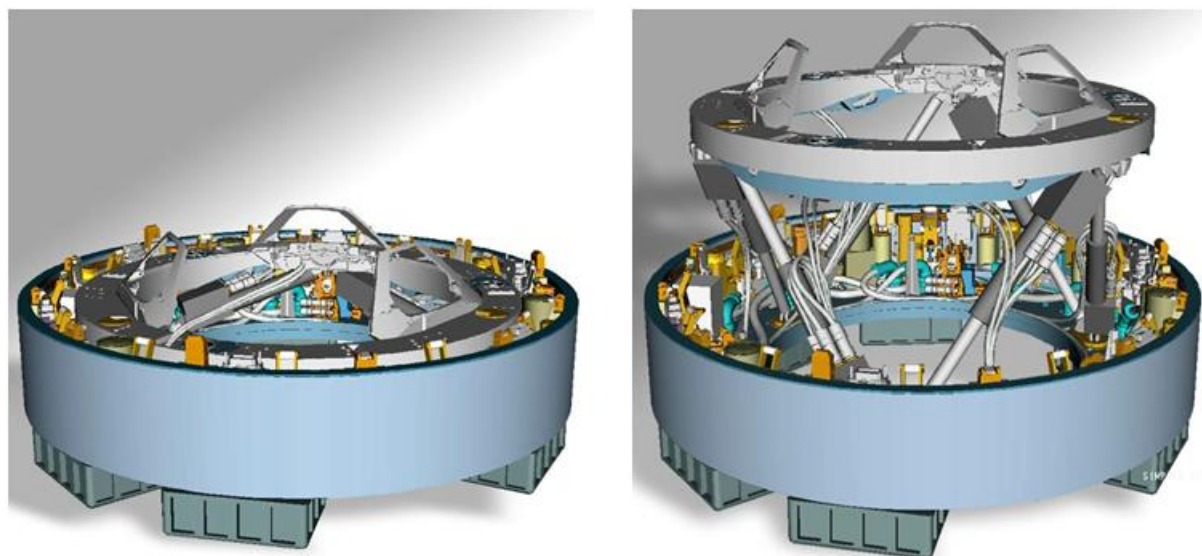

Figure 1 The IBDM equipped with the first generation latching system

### General Objective

The IBDM latching system will provide the structural connection between two mated space vehicles after berthing or docking. The mechanism guarantees that the interface seals become compressed to form a leak-tight pressure system that creates a passageway for the astronauts.

### The First Generation Latching System

#### Introduction

The initial latch design was driven by the requirements of the NASA X-38/CRV spacecraft, being the envisaged 7-crew astronaut rescue vehicle for the ISS. This implied that the mechanism had to be single fault tolerant for docking (no catastrophic hazard when in LEO) and dual fault tolerant for undocking (i.e., release).

---

\* Verhaert Space, Kruike, Belgium

\*\* ESA/ESTeC, Noordwijk, The Netherlands

### Description of the first generation latching system

The general architecture of the latching system (Figure 2) consists of twelve latches and an equal number of latch tabs per IBDM. All are mounted on the inside of the IBDM tunnel wall and are oriented in a radial direction. The androgynous concept of the IBDM enables each latch to mate with a corresponding latch tab on the side of a mating vehicle. The latches can be driven via two independent ring gears that take care of the synchronization between all latches. Each ring gear is individually actuated by a redundant electro-motor.



**Figure 2 The Latch (left) and Latch Tab (right) of the first generation latching system**

The latch mechanism kinematics are a combination of two 4-bar linkages. The latch has a roller interface for landing onto the hook of a latch tab. The redundancy in the latch release is accomplished by a primary and a secondary drive, plus a pyrotechnic solution. Additionally, a pyro-release capability can also be implemented into the latch tab. The latch tabs each hold a load-limiting device that becomes geometrically positioned in line with the load path of the latch in order to have a minimal hysteresis in the load-limiter operation.

High design loads, the complexity of the design, and the small available volume within the IBDM tunnel have pushed the design of the latch mechanism to the limits. Even with the use of super alloys (MP35N, Custom-455) and the selection of a customized bushing, only minimal positive structural margins of safety could be accomplished.

### Shortcomings of the first generation latching system

During the functional testing of the mechanism several anomalies were observed. These are the major findings:

- In the nominal situation (i.e., as required), the kinematics of the latch are designed to follow a vertical trajectory in the final phase of latching (i.e., the roller of the latch approaching the hook of the latch tab, see Figure 3), limiting any transverse loads on the latch mechanism. However, during functional testing, the trajectory showed a motion of the roller towards the edge of the latch tab hook. This happened due to flexibility of the secondary drive elements of the latch that created a bigger than expected deflection of the latch linkages involved.  
Test conclusion: the design concept of the latching system appeared not to be safe against inadvertent release of the mechanism (i.e., the latch roller snapping of the latch tab). Therefore, this latching system is no reliable device for a structural connection.
- In order to minimize the primary drive torque to close the latch, the diameter of the free rotating pins had to be reduced. Therefore, custom-sized commercial parts were needed. These were dry-lubricated bushings with a larger L/D ratio than nominal (off-the-shelf) units. It was discovered that the assumptions made for the strength verification of standard parts are not valid for the dimensions of the customized bushings. This was not anticipated by the parts supplier. The load bearing capability of the custom-sized bushings appeared to be lower than the load capability of

standard bushings with the net result that the load capability of the latch/latch tab combination was lower than anticipated.

Test conclusion: Pin and bushing failures have been observed at a significantly lower load level compared to the values predicted by analysis.

- From a very early stage of the development, factors of safety were introduced on the applied loads. Due to the non-linear behavior of the latching system due to the presence of a load-limiter in the latch tab, the structural margin of safety on the resulting stresses are low.

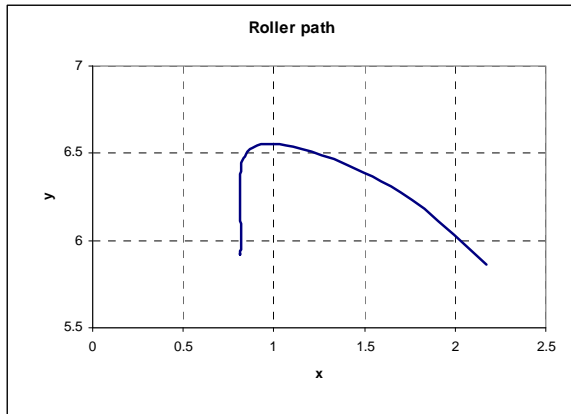

**Figure 3 Theoretical (left) versus measured (right) trajectory of the Latch onto the Latch Tab**

#### Lessons learned from the first generation latching system

A thorough investigation of the observed anomalies resulted in a number of valuable lessons learned:

- The shape of the latch tab hook has to be properly controlled by careful factoring of the relative stiffness of the latch and the tunnel, the mounting tolerances and differential thermal expansion. Additionally, positive locking of the latch must be incorporated to prevent the roller interface at all times to snap off the latch tab at (excessive) load increase.
- Avoid as much as possible dual use for both the primary and the secondary drive of single linkage joints.
- Due to the exceptional characteristics of the space environment and the limitations in mass and envelope imposed to any space equipment, the design of structural elements, in particular pins and bushings, cannot be done based on suppliers or textbook generic formulas. Careful estimations of stresses and deformations have to be carried out by FEM, even for simple geometries. Material allowables must be determined by test. Breadboarding and testing of function critical or highly stress elements must be always carried out and results correlated with the FEM models.
- The optimal dimensional relations (i.e., small L/D ratio) for the structural strength of the bushing should be maintained as much as possible. Non-linear contact analysis showed that bushings with a large L/D ratio show a big variation in the stresses in the bushing liner, while this is much less for bushings with a small L/D.
- Suppliers of COTS equipment may only have limited knowledge of their products, usually only around the qualification range of the first product that used the element. It is not always an option to design space mechanisms so they comply with the known environment of these COTS parts, therefore, supplier's calculations and analysis methods have to be carefully assessed and verified by test under the foreseen environment and conditions early in the project when corrective actions or alternative designs can be considered.
- Apply the structural factor of safety on the resulting stresses instead of on the applied loads.

## The Second Generation Latching System

### Introduction

After cancellation of the X-38 program by NASA, ESA decided to independently pursue the IBDM development – comprising the further optimization of the latching system – for implementation of this docking mechanism into their Space Exploration plans. The second generation latch did therefore take into account the above-mentioned lessons learned, while establishing even more severe requirements for the Exploration purposes. For example, the latching system not only had to be dual fault tolerant for undocking, but also had to become dual fault tolerant for docking.

The size of the second generation latch was enlarged with respect to the first generation latch to assess the feasibility of an increased IBDM tunnel diameter (to also allow for ISPR-racks to pass through the tunnel instead of astronauts only). The second generation latch did focus on the optimization of the primary drive and did therefore not consider the design of a secondary release mechanism in order to fulfil the dual fault tolerance requirement. However, the new overall design concept introduces a redundant release function by the possibility to operate the latching system on the other vehicle side.

### Design improvements for the second generation latching system

In order to comply with the more stringent requirements, the following design modifications with respect to the first generation latching system have been incorporated:

- Modification of the overall design concept, in which:
  - the combination of latch and latch tab became replaced by the generic hook-on-hook principle. Therefore each latch will mate with an identical counterpart on the other vehicle side, resolving the necessity for the IBDM to carry the mass of unutilized elements that are imposed for androgyny (i.e., the latch tabs on a passive IBDM).
  - the common drive train has been replaced by an independent motor plus gearbox for each latch.
- Latches have moved from the inside of the tunnel wall to the outside and are oriented in a tangential direction.
- A compliance element has been integrated into the design of the latch itself. Therefore, two mated IBDMs feature double of the latch compliance.
- Inherent positive locking of the latch is incorporated.
- A (primary) drive kinematics has been accomplished that is no longer dominated by the diameter of the pins in the joints. Therefore, the bushings can now be correctly sized (i.e., increased) to the latch load. For reasons of completeness, it has to be mentioned that as a negative consequence, friction losses due to a bigger pin diameter are now a little higher compared to the first generation latch design, resulting in a lower overall mechanical efficiency.
- Conservative factors of safety (1.25 for yield and 1.5 for ultimate) have been taken on the design load stress.

The second generation latch contains a primary drive with linkage kinematics similar to the previous latch design (i.e., a combination of two 4-bar linkages). In analogy to the first generation latch, this results in a vertical trajectory for the operated hook when it approaches its mating counterpart at the final phase of latching.

### Lessons learned from the second generation latching system

Hardware has been built and has been subjected to stringent functional and structural tests (Figure 4). The following lessons learned are recorded:

- The hook-on-hook concept does guarantee a stable structural connection.
- The number of moving parts in the latch drive chain has to be (further) reduced as much as possible. Any moving part increases the risk of jamming the mechanism and more joints in the latch leads to lower transmission efficiency. A longer drive train through many linkages results in more difficult control in the synchronization of the release of all latches.

- The load path from the interface load to the load-limiter has to be decreased as much as possible, in order to avoid hysteresis in the load-limiter operation.



**Figure 4 Functional and structural testing of the second generation latching system**

### The (Present) Third Generation Latching System

#### Introduction

The latest latch design is derived from the second generation latch. It maintains the hook-on-hook concept, but the kinematics are restricted to a single 4-bar linkage. The size of the latch is reduced back to that of the first generation latch (i.e., the size of the latch/latch tab, intended for an IBDM tunnel diameter that allows astronaut passage only).

Per IBDM, 12 latches are attached in a tangential direction to the outside of the tunnel wall (Figure 5). Each latch has its proper motor, gearbox and adjustable compliance element. The motor and the gearbox are developed as an integrated actuator unit. Dual failure tolerance has been established for both docking and undocking, and inherent positive locking of the mechanism provides the guarantee against inadvertent release.

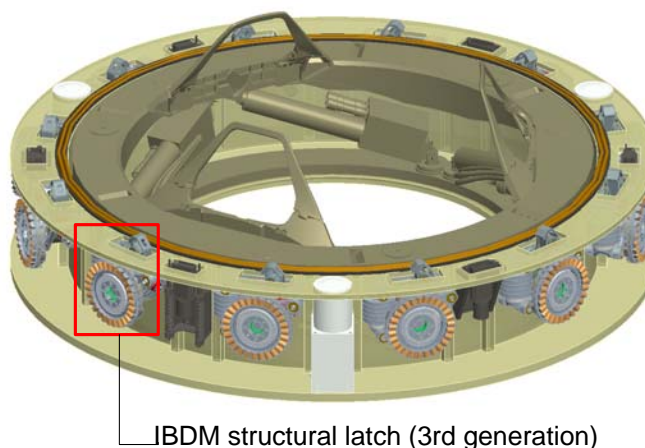

**Figure 5 The IBDM with the third generation latching system**

Design improvements for the third generation latching system

- The load capability has been significantly increased while the overall mass of the latching system could be slightly reduced (with respect to the latch/latch tab concept, see Figure 6). At the same time, even more standard materials have been applied, like Al 7075 for the latch housing.
- A substantial improvement in mechanical efficiency and reliability could be realized through a simplified design that reduced the number of linkages in the load path of the latch primary drive to a minimum. The short drive train to the latch hook also leads to accurate control in the synchronization of the release of all latches.
- The latch design includes a secondary release mechanism, which:
  - accomplishes the dual fault tolerance requirement.
  - takes into account the Limited Life Item policy for pyrotechnics (i.e., the pyrotechnic release capability being provided on the visiting vehicle only).

The latch secondary drive consists out of tilting the latch hook by rupturing the hold-down bolt. Rupturing the bolt can be done with a Frangibolt actuator or with a rich cut bolt (pyrotechnic).

- The joints in the direct load path of the latch are now equipped with roller bearings instead of bushings, resulting in an increased drive efficiency.
- The load path from the interface load to the load limiter has been shortened, resulting in minimal hysteresis in the load limiter operation.

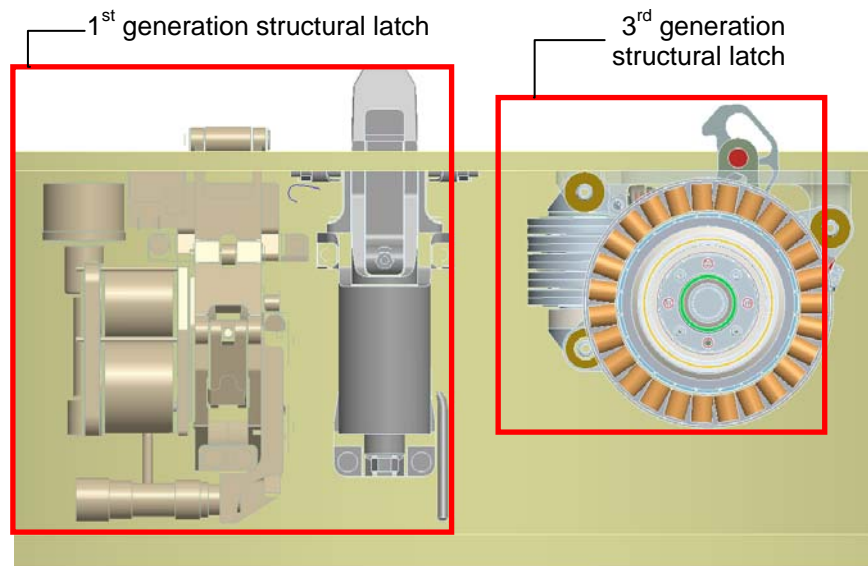

- |  |  |
|--|--|
| <ul style="list-style-type: none"> <li>▪ Design load: 34 kN (7640 lbf)</li> <li>▪ Single fault tolerant</li> <li>▪ Mechanical drive efficiency: 66%</li> </ul> | <ul style="list-style-type: none"> <li>▪ Design load: 57 kN (12800 lbf)</li> <li>▪ Dual fault tolerant</li> <li>▪ Mechanical drive efficiency: 80%</li> <li>▪ Reduced mounting envelope</li> </ul> |
|--|--|

**Figure 6 Comparison of 1<sup>st</sup> generation structural latch vs. 3<sup>rd</sup> generation structural latch**

### Design verification tests on the third generation latching system

Two prototype hardware models are built and they have recently been functionally and structurally tested. By test, a few less-favorable consequences of this generic simplified latch design have been verified for their potential impact on the functionality of the latch.

The investigated points of concern of the present latch design were the following:

- Due to the latch primary drive kinematics consisting out of a single 4-bar linkage, the latch hook will no longer land on its mating counterpart in a straight vertical trajectory. Instead, the hook now has to slide off the mated hook for release. Despite the fact that the latch hooks have been Niflor-coated, friction between the contact surfaces has been increased compared to the separation scenario with a roller interface (being used in the first generation latching system).
- Release capability tests with the push-off force<sup>1</sup> have been executed. The push-off force being applied to the latch is the worst-case condition of two side-by-side latch failures out of all 12 latches.  
Test conclusion: all tests did demonstrate the capability of the hooks to release without a problem.
- A preloaded compression spring to the side of the latch hook has to force the hook to close when rotating the latch crank to the closed position.  
Test conclusion: test did show that this functionality was also working fine while an LVDT attached to the other side of the latch hook monitors the movement of the hook.

### **Conclusion**

Testing of the latest latch system has demonstrated the capability to design a stable structural connection device that is made dual fault tolerant for both docking and undocking of the IBDM. Design optimization of the mechanism has been realized through analysis and validation of three concept generations. This was accomplished by consistently taken into account the numerous lessons learned that have been gathered along the way. It resulted in a generic simplified design of the IBDM latching system that features an optimized mechanical drive efficiency<sup>2</sup>, mass efficiency<sup>3</sup> and reliability<sup>4</sup>.

---

<sup>1</sup> A push-off force is being exerted on the latch by an energized separation system that must provide the IBDM with a prescribed delta-velocity in case of an expedited departure.

<sup>2</sup> Mechanical drive efficiency being expressed as the ratio between the required drive torque without and with friction losses in the linkages.

<sup>3</sup> Mass efficiency being expressed as the ratio for the load capability versus the mass of the latching system.

<sup>4</sup> Reliability being expressed as the inverse of the amount of moving parts per drive (considering each moving part as a potential single point of failure).

