

**Exercises in GCSE
Mathematics
Foundation Level
Robert Joinson**

Sumbooks

Sumbooks Chester CH4 8BB

Exercises in GCSE Mathematics-Foundation level

First Published 1998

Updated 2002

New Edition 2006

Copyright R Joinson and **Sumbooks**

This package of worksheets is sold subject to the condition that it is photocopied for educational purposes only on the premises of the purchaser.

ISBN 0 9543580 1 5

Preface

This book covers the GCSE syllabi examined for the first time in 2003 and the foundation part of the new two tier examination system beginning in September 2006.

All graphs can be accommodated on A4 size graph paper used in 'portrait' mode.

I would like to thank my wife Jenny and my two daughters Abigail and Hannah for all the help and encouragement they have given me in writing this.

R Joinson

September 2006
Chester

Foundation Level Contents

1. Rounding Off and Estimating
2. Estimation 1
3. Estimation 2
4. Reading and Writing Whole Numbers
5. Multiplying and Dividing by 10, 100 etc
6. Multiplication and Division
7. Ordering Directed Numbers
8. Use of the Calculator 1
9. Use of the Calculator 2
10. Types of Numbers
11. Standard Form
12. Prime Factors
13. Recurring Decimals
14. Fractions, Decimals and Percentages 1
15. Fractions, Decimals and Percentages 2
16. Fractions, Decimals and Percentages 3
17. Fractions, Decimals and Percentages 4
18. Interest
19. Ratio and Proportion
20. Personal and Household Finance
21. Tables
22. Conversion Graphs 1
23. Conversion Graphs 2
24. Distance Time Diagrams 1
25. Distance Time Diagrams 2
26. Trial and Improvement 1
27. Trial and Improvement 2
28. Number Patterns and Sequences 1
29. Number Patterns and Sequences 2
30. Indices
31. Number Machines
32. Substitution 1
33. Substitution 2
34. Forming Expressions
35. Simplifying Expressions 1
36. Simplifying Expressions 2
37. Multiplying Brackets
38. Factorising
39. Rearranging Formulae
40. Making and Solving Equations
41. Equations
42. More Equations
43. Simultaneous Equations
44. Using Simple Equations
45. Using Quadratic Equations
46. Co-ordinates
47. Sketching and Recognising Graphs 1

48. Sketching and Recognising Graphs 2
49. Recognising Graphs
50. Plotting Graphs 1
51. Plotting Graphs 2
52. Plotting Graphs 3
53. Straight Line Graphs
54. Inequalities
55. Inequalities - Graphs
56. Angles
57. Triangles 1
58. Triangles 2
59. Shapes
60. Quadrilaterals
61. Regular Polygons
62. Irregular Polygons
63. Congruency
64. Tessellations
65. Nets and Isometric Drawings 1
66. Nets and Isometric Drawings 2
67. Reflection Symmetry
68. Reflection
69. Enlargements
70. Rotational Symmetry
71. Rotation
72. Translation 1
73. Translation 2
74. Reflections, Rotations and Translations 1
75. Reflections, Rotations and Translations 2
76. Enlargement Through a Point 1
77. Enlargement Through a Point 2
78. Enlargement Through a Point 3
79. Planes of Symmetry
80. Similar Shapes
81. Locus Problems 1
82. Locus Problems 2
83. Constructions
84. Scale Drawings
85. Plans
86. Plans and Elevations 1
87. Plans and Elevations 2
88. Plans and Elevations 3
89. Plans and Elevations 4
90. Using Measurements
91. Degree of Accuracy
92. Bearings
93. Areas and Perimeters 1
94. Areas and Perimeters 2
95. Circumference of a Circle
96. Area of a Circle
97. Volume 1

98. Volume 2
99. Formulae for Area Volume and Perimeter 1
100. Formulae for Area Volume and Perimeter 2
101. Time
102. Density
103. Best Buys and Painting
104. Speed
105. More Best Buys
106. Pythagoras Theorem
107. Trigonometry 1
108. Trigonometry 2
109. Trigonometry 3
110. Trigonometry 4
111. Surveys and Questionnaires
112. Pictograms
113. Pie Charts 1
114. Pie Charts 2
115. Bar Charts
116. Stem and Leaf Diagrams
117. Box Plots
118. Line Graphs
119. Scatter Diagrams 1
120. Scatter Diagrams 2
121. Mean 1
122. Mean 2
123. Mean 3
124. Mean 4
125. Mean 5
126. Grouped Frequency
127. Median, Mode and Range
128. Mean, Median, Mode and Range
129. Moving Averages
130. Frequency Polygons
131. Cumulative Frequency 1
132. Cumulative Frequency 2
133. Probability 1
134. Probability 2
135. Probability 3
136. Probability 4
137. Probability 5
138. Tree Diagrams
139. Relative Frequency 1
140. Relative Frequency 2

1. Rounding off and Estimating

Do not use a Calculator

Exercise 1

Round off the following numbers in the way stated

- 1) 67 to the nearest 10
- 2) 93 to the nearest 10
- 3) 141 to the nearest 10
- 4) 289 to the nearest 10
- 5) 721 to the nearest 100
- 6) 473 to the nearest 100
- 7) 846 a) to the nearest 10 and b) to the nearest 100
- 8) 365 a) to the nearest 10 and b) to the nearest 100
- 9) 2346 a) to the nearest 100 and b) to the nearest 1000
- 10) 5876 a) to the nearest 10, b) to the nearest 100 and c) to the nearest 1000

Exercise 2

- 1) The number of boys in a school is 456 and the number of girls is 512.
 - a) Round off both numbers to the nearest 100 and estimate the total number of pupils at the school.
 - b) Round off both numbers to the nearest 10 and do a similar estimate.
- 2) A theatre has 37 rows each with 22 seats. The total number of seats is 37×22 .
 - a) Write down the numbers you would use to get an estimate of the answer.
 - b) Calculate this estimate.
- 3) A CD player costs £167 and a TV costs £280. What simple calculation would you do to show that the total cost is less than £500?
- 4) A jar of jam costs 57p, a tub of margarine costs 48p and a bottle of sauce costs 77p. What simple calculation would you do to show that the total cost is less than £2.00?
- 5) Tickets for a concert cost £5.75 each. A group of 18 people went to the concert. What simple calculation would you use to show that the total cost is less than £120?
- 6) I travel 57 miles from home to Birmingham. I then go to my gran's house, a further 36 miles from Birmingham. What simple calculation must I do to show that I have not travelled more than 100 miles?
- 7) A bus is hired to take a group of pupils on a trip. The bus seats 48 passengers. If the cost of each fare is £2.80, show that the total cost for the group is less than £150.
- 8) A book costs £5.49. If I buy it with a £20 note, do a simple calculation to show that my change is less than £15.
- 9) A case of wine contains 12 bottles. In a store room there are 37 cases. Approximately how many bottles is this? Show how you would do this estimate.

Exercise 3

Estimate the value of each of the following. In each case show how it was done.

- | | | | |
|-------------------------------|--------------------------------|--------------------------------|--------------------------------|
| 1) 54×27 | 2) 34×45 | 3) 12×63 | 4) 54×63 |
| 5) 86×43 | 6) 54×25 | 7) 104×38 | 8) 163×21 |
| 9) 39×123 | 10) 73×190 | 11) $203 \div 21$ | 12) $120 \div 19$ |
| 13) $164 \div 22$ | 14) $235 \div 24$ | 15) $582 \div 27$ | 16) $810 \div 21$ |
| 17) $983 \div 47$ | 18) $1573 \div 42$ | 19) $2056 \div 52$ | 20) $2764 \div 68$ |
| 21) $\frac{32 \times 43}{6}$ | 22) $\frac{21 \times 43}{8}$ | 23) $\frac{52 \times 43}{5}$ | 24) $\frac{32 \times 43}{19}$ |
| 25) $\frac{321 \times 4}{31}$ | 26) $\frac{396 \times 23}{41}$ | 27) $\frac{571 \times 33}{57}$ | 28) $\frac{321 \times 43}{61}$ |

2. Estimation 1

Do not use a calculator

In each of the following questions a) write down a calculation that could be done to check the answer and b) write down your answer to the estimation.

Exercise 1

- | | | | |
|-------------------|-------------------|--------------------|--------------------|
| 1) $22.5 + 57.7$ | 2) $17.6 + 61.4$ | 3) $87.3 + 62.7$ | 4) $59.3 + 81.6$ |
| 5) $38.4 - 17.6$ | 6) $59.6 - 28.4$ | 7) $83.5 - 41.6$ | 8) $84.9 - 35.3$ |
| 9) $73.4 + 28.1$ | 10) $23.3 + 48.7$ | 11) $91.2 + 57.6$ | 12) $43.5 + 67.3$ |
| 13) $87.4 - 26.9$ | 14) $75.2 - 33.9$ | 15) $107.6 - 66.7$ | 16) $142.3 - 84.9$ |

Exercise 2

- | | | | | |
|---------------------|---------------------|---------------------|---------------------|---------------------|
| 1) 81×18 | 2) 43×21 | 3) 62×29 | 4) 76×33 | 5) 104×19 |
| 6) 54×29 | 7) 137×24 | 8) 79×41 | 9) 117×57 | 10) 173×9 |
| 11) 246×13 | 12) 354×31 | 13) 507×39 | 14) 607×51 | 15) 683×52 |

Exercise 3

- | | | | | |
|---------------------|---------------------|---------------------|---------------------|---------------------|
| 1) 3.7×6 | 2) 5.2×5 | 3) 7.9×8 | 4) 6.3×11 | 5) 4.2×16 |
| 6) 7.1×23 | 7) 4.5×31 | 8) 3.9×37 | 9) 8.4×49 | 10) 6.3×26 |
| 11) 9.3×53 | 12) 6.4×71 | 13) 8.2×42 | 14) 3.9×63 | 15) 6.7×82 |

Exercise 4

- | | | | | |
|-----------------------|-----------------------|-----------------------|-----------------------|-----------------------|
| 1) 4.2×3.1 | 2) 5.3×7.8 | 3) 9.3×6.3 | 4) 5.2×4.9 | 5) 6.7×3.7 |
| 6) 3.9×5.2 | 7) 7.6×8.4 | 8) 9.5×6.3 | 9) 5.8×2.9 | 10) 7.9×8.4 |
| 11) 4.9×10.2 | 12) 7.6×11.5 | 13) 2.4×20.6 | 14) 8.7×19.8 | 15) 4.3×18.7 |

Exercise 5

- | | | | | | |
|------------------------|------------------------|------------------------|------------------------|------------------------|------------------------|
| 1) $\frac{31}{5.2}$ | 2) $\frac{43}{8.6}$ | 3) $\frac{56}{11.1}$ | 4) $\frac{93}{18}$ | 5) $\frac{65.2}{9}$ | 6) $\frac{87}{9.2}$ |
| 7) $\frac{56.1}{27.2}$ | 8) $\frac{87.3}{32.1}$ | 9) $\frac{62.3}{16.1}$ | 10) $\frac{38.9}{9.7}$ | 11) $\frac{107}{32.1}$ | 12) $\frac{123}{41.3}$ |
| 13) $\frac{145}{7.1}$ | 14) $\frac{193}{38.7}$ | 15) $\frac{308}{48.2}$ | 16) $\frac{112}{10.8}$ | 17) $\frac{385}{77}$ | 18) $\frac{523}{18.6}$ |

Exercise 6

- | | | | |
|--|---|---|--|
| 1) $\frac{84.2}{3.8 \times 5.2}$ | 2) $\frac{57.4}{2.3 \times 4.8}$ | 3) $\frac{93.5}{2.8 \times 3.1}$ | 4) $\frac{47.6}{1.9 \times 2.9}$ |
| 5) $\frac{14.7 + 27.1}{4.1}$ | 6) $\frac{3.2 + 16.7}{10.2}$ | 7) $\frac{34.8 + 58.3}{15.2}$ | 8) $\frac{74.3 - 21.4}{5.1}$ |
| 9) $\frac{54.7 - 13.6}{22.3}$ | 10) $\frac{19.7 + 53.2}{14.3}$ | 11) $\frac{35.4 - 6.1}{2.1 \times 2.9}$ | 12) $\frac{67 + 84.3}{7.2 \times 1.9}$ |
| 13) $\frac{68.7 - 25.5}{4.2 \times 9.5}$ | 14) $\frac{14.3 \times 25.4}{7.1 \times 5.1}$ | 15) $\frac{7.9 \times 33.4}{8.6 \times 10.9}$ | 16) $\frac{24.3 \times 37.4}{10.8 \times 4.1}$ |

3. Estimation 2

Do not use a calculator

In each of the following questions a) write down a calculation that could be done mentally to check the answer to each of the following and b) write down your answer

Exercise 1

- | | | | |
|----------------------|----------------------|----------------------|----------------------|
| 1) 27×56 | 2) 32×67 | 3) 48×53 | 4) 78×46 |
| 5) 81×44 | 6) 53×62 | 7) 71×89 | 8) 102×53 |
| 9) 96×156 | 10) 87×162 | 11) 167×109 | 12) 203×174 |
| 13) 287×415 | 14) 536×851 | 15) 365×424 | 16) 212×482 |
| 17) 264×387 | 18) 543×77 | 19) 643×88 | 20) 456×325 |

Exercise 2

- | | |
|--|--|
| 1) 6.314×2.876 | 2) 15.914×32.14 |
| 3) 17.68×57.58 | 4) 9.32×0.076 |
| 5) $15.421 \times .0034$ | 6) 0.00234×0.0157 |
| 7) $37.6 - 9.4$ | 8) $17.73 - 4.65$ |
| 9) $14.32 - 2.98$ | 10) $8.65 - 0.357$ |
| 11) $0.631 - 0.214$ | 12) $\frac{3.54 \times 2.64}{4.31}$ |
| 13) $\frac{5.64 \times 14.78}{5.74}$ | 14) $\frac{7.64 + 3.87}{2.56}$ |
| 15) $\frac{5.31 + 2.64}{3.74 - 1.68}$ | 16) $\frac{7.32 \times 4.28}{1.64 \times 3.17}$ |
| 17) $\frac{0.314 \times 2.64}{4.13}$ | 18) $\frac{6.43 + 4.95}{0.341}$ |
| 19) $\frac{3.152 \times 0.48}{2.63}$ | 20) $\frac{2.31 - 1.42}{3.64}$ |
| 21) $\frac{7.43 \times (4.35)^2}{230 + 175}$ | 22) $\frac{(6.82)^2 \times 17.34}{8.97 - 3.14}$ |
| 23) $\frac{3.14(4.85 + 3.94)}{8.32 - 2.15}$ | 24) $\frac{(3.78)^3 - 4.79}{0.156 \times 0.734}$ |
- 25) If $v = 2 \times 9.81 \times 17.4$ estimate the value of v .
- 26) If $c = 2.21 \times 13.6 \times 5.2 - 13.6$ estimate c .
- 27) $t = \frac{2.54 \times 37.2}{9.82}$ estimate the value of t .
- 28) $D = \frac{3.54(6.48 + 3.21)}{6.48 - 3.21}$ estimate the value of D .
- 29) Estimate the value of $8 \times 8 \times 10 \times 11 \times 12$.

4. Reading and Writing Whole Numbers

Exercise 1 Write in words the following numbers

- | | | | | |
|---------------|---------------|---------------|---------------|---------------|
| 1) 106 | 2) 214 | 3) 356 | 4) 597 | 5) 893 |
| 6) 1342 | 7) 4327 | 8) 5302 | 9) 7102 | 10) 8073 |
| 11) 11,345 | 12) 14,536 | 13) 27,356 | 14) 54,362 | 15) 73,002 |
| 16) 163,765 | 17) 374,305 | 18) 340,000 | 19) 543,009 | 20) 600,087 |
| 21) 6,000,000 | 22) 4,762,800 | 23) 5,700,345 | 24) 4,000,764 | 25) 7,100,067 |

Exercise 2 Write in number form the following

- | | |
|---|--|
| 1) One hundred and fifty six | 2) Seven hundred and six |
| 3) Four hundred and seven | 4) Six hundred and seventy |
| 5) Three thousand | 6) Four thousand three hundred and sixty seven |
| 7) Two thousand and eighty | 8) Six thousand and six |
| 9) Five thousand and sixty seven | 10) Nine thousand, nine hundred and ninety |
| 11) Twenty seven thousand | 12) Forty thousand |
| 13) Sixty three thousand and five | 14) Eighty seven thousand, five hundred |
| 15) Seventy seven thousand, four hundred and twenty two | |
| 16) Eighteen thousand nine hundred and fifty seven | |
| 17) Two hundred thousand | 18) One hundred and sixty seven thousand |
| 19) Three hundred and twenty four thousand, five hundred and fifty six | |
| 20) Seven hundred and fifty four thousand and seventy two | |
| 21) Three million | 22) Four million, nine hundred thousand |
| 23) Seven million, one hundred and sixteen thousand, nine hundred and fifty six | |
| 24) Six million, fourteen thousand, nine hundred and fifty seven | |
| 25) Eight million, seven hundred and fifty three thousand and two | |

Exercise 3

- 1) Add together one thousand six hundred and four, and seventy nine.
- 2) Add together seven hundred and sixty three and three hundred and twenty seven.
- 3) What is one hundred and forty seven add eighty four?
- 4) Subtract seventy six from one hundred and fifty two.
- 5) What is the answer when fifty four is taken away from one hundred and five?
- 6) What is the difference between fifty nine and two hundred?
- 7) Calculate the sum of five hundred and thirty nine and, three hundred and seventeen
- 8) Add together two thousand and sixty eight and one hundred and seventy one.
- 9) What is seventy one subtracted from one hundred and fifty?
- 10) What is three hundred and forty subtract ninety two?

Exercise 4 Write down each answer in words.

- 1) What is the value of the 5 in the number 354?
- 2) What is the value of the 7 in the number 1734?
- 3) What is the value of the 3 in the number 3256?
- 4) What is the value of the 2 in the number 1852?
- 5) What is the value of the 1 in the number 17,450?
- 6) What is the value of the 6 in the number 16,802?
- 7) What is the value of the 9 in the number 394,145?
- 8) What is the value of the 3 in the number 3,654,990?
- 9) What is the value of the 8 in the number 5,835,000?
- 10) What is the value of the 7 in the number 6,670,000?

5. Multiplying and Dividing by 10, 100 etc

Do not use a Calculator

Exercise 1

Write down the answer to each of the following

- | | | | |
|----------------------|------------------------|------------------------|-------------------------|
| 1) 6×10 | 2) 17×10 | 3) 36×10 | 4) 124×10 |
| 5) 674×10 | 6) 4×100 | 7) 25×100 | 8) 14×100 |
| 9) 362×100 | 10) 760×100 | 11) 7×1000 | 12) 38×1000 |
| 13) 97×1000 | 14) 270×1000 | 15) $38 \times 10,000$ | 16) $420 \times 10,000$ |
| 17) $70 \div 10$ | 18) $400 \div 10$ | 19) $920 \div 10$ | 20) $2100 \div 10$ |
| 21) $300 \div 100$ | 22) $4000 \div 100$ | 23) $8200 \div 100$ | 24) $10,000 \div 100$ |
| 25) $6000 \div 1000$ | 26) $16,000 \div 1000$ | 27) $20,000 \div 1000$ | 28) $37,000 \div 1000$ |

Exercise 2

Write down the answer to each of the following

- | | | | |
|-------------------------|--------------------------|------------------------|--------------------------|
| 1) 1.3×10 | 2) 7.4×10 | 3) 12.2×10 | 4) 27.6×10 |
| 5) 2.87×10 | 6) 5.38×10 | 7) 72.64×10 | 8) 123.67×10 |
| 9) 3.47×100 | 10) 7.50×100 | 11) 16.48×100 | 12) 128.37×100 |
| 13) 4.6×100 | 14) 18.5×100 | 15) 173.6×100 | 16) 872.4×100 |
| 17) 2.532×1000 | 18) 12.673×1000 | 19) 2.46×1000 | 20) 341.4×1000 |
| 21) 0.3×10 | 22) 0.456×10 | 23) 0.02×10 | 24) 0.0074×10 |
| 25) 0.5×100 | 26) 0.19×100 | 27) 0.937×100 | 28) 0.002×100 |
| 29) 0.023×1000 | 30) 0.37×1000 | 31) 0.4×1000 | 32) 0.0532×1000 |

Exercise 3

Write down the answer to each of the following

- | | | | |
|------------------------|------------------------|-----------------------|-----------------------|
| 1) $2 \div 10$ | 2) $2.7 \div 10$ | 3) $17 \div 10$ | 4) $153 \div 10$ |
| 5) $6.34 \div 10$ | 6) $0.34 \div 10$ | 7) $0.056 \div 10$ | 8) $0.002 \div 10$ |
| 9) $2.43 \div 100$ | 10) $48.4 \div 100$ | 11) $327 \div 100$ | 12) $1870 \div 100$ |
| 13) $0.367 \div 100$ | 14) $0.67 \div 100$ | 15) $0.0183 \div 100$ | 16) $0.5 \div 100$ |
| 17) $6 \div 1000$ | 18) $16 \div 1000$ | 19) $2.6 \div 1000$ | 20) $27.45 \div 1000$ |
| 21) $0.3765 \div 1000$ | 22) $0.0254 \div 1000$ | 23) $0.034 \div 1000$ | 24) $0.03 \div 1000$ |

Exercise 4

- 1) What must 238 be multiplied by to get 23800?
- 2) What must 14.6 be multiplied by to get 14600?
- 3) What must 0.034 be multiplied by to get 34?
- 4) What must 736 be divided by to get 7.36?
- 5) What must 6 be divided by to get 0.006?
- 6) What must 0.087 be divided by to get 0.00087?
- 7) If 12 is multiplied by 1000 what is the value of the 2 in the answer?
- 8) If 0.389 is multiplied by 1000, what is the value of the 8 in the answer?
- 9) If 23 is divided by 100, what is the value of the 3 in the answer?
- 10) If 0.27 is divided by 100, what is the value of the 7 in the answer?

6. Multiplication and Division

Do not use a calculator

Exercise 1

Short division with or without remainders

- | | | | |
|-----------------|------------------|------------------|------------------|
| 1) $65 \div 5$ | 2) $91 \div 7$ | 3) $82 \div 4$ | 4) $121 \div 3$ |
| 5) $143 \div 6$ | 6) $203 \div 5$ | 7) $216 \div 9$ | 8) $664 \div 8$ |
| 9) $378 \div 7$ | 10) $522 \div 6$ | 11) $338 \div 8$ | 12) $476 \div 4$ |

Exercise 2

Long division with or without remainders

- | | | | |
|-------------------|-------------------|-------------------|-------------------|
| 1) $96 \div 14$ | 2) $112 \div 16$ | 3) $93 \div 13$ | 4) $112 \div 22$ |
| 5) $162 \div 18$ | 6) $408 \div 34$ | 7) $453 \div 27$ | 8) $174 \div 24$ |
| 9) $332 \div 25$ | 10) $341 \div 31$ | 11) $243 \div 35$ | 12) $285 \div 19$ |
| 13) $258 \div 26$ | 14) $682 \div 31$ | 15) $576 \div 36$ | 16) $476 \div 42$ |
| 17) $553 \div 34$ | 18) $533 \div 41$ | 19) $972 \div 36$ | 20) $779 \div 27$ |

Exercise 3

Division without remainders (answer in decimal form)

- | | | | |
|-------------------|-------------------|-------------------|------------------|
| 1) $22.0 \div 4$ | 2) $15.0 \div 2$ | 3) $57 \div 5$ | 4) $33 \div 6$ |
| 5) $41 \div 2$ | 6) $37 \div 4$ | 7) $122 \div 8$ | 8) $106 \div 5$ |
| 9) $99 \div 6$ | 10) $145 \div 4$ | 11) $87 \div 5$ | 12) $134 \div 4$ |
| 13) $204 \div 8$ | 14) $258 \div 4$ | 15) $312 \div 5$ | 16) $454 \div 4$ |
| 17) $27.4 \div 8$ | 18) $36.8 \div 4$ | 19) $23.4 \div 6$ | 20) $343 \div 4$ |

Exercise 4

Long multiplication

- | | | | | |
|---------------------|---------------------|---------------------|---------------------|---------------------|
| 1) 17×22 | 2) 41×15 | 3) 31×22 | 4) 35×27 | 5) 56×36 |
| 6) 94×37 | 7) 121×17 | 8) 153×29 | 9) 157×54 | 10) 206×31 |
| 11) 221×54 | 12) 447×66 | 13) 381×71 | 14) 734×34 | 15) 236×37 |
| 16) 756×63 | 17) 371×45 | 18) 431×34 | 19) 441×39 | 20) 438×67 |

7. Ordering Directed Numbers

Exercise 1

1) Copy the number line below and mark on the numbers

20 -10 -30 12 -5 5 -28 -13

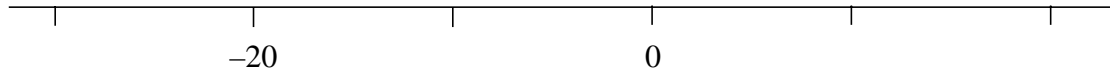

2) Copy the number line below and mark on the numbers

-1 1.6 $-\frac{1}{2}$ 2 $1\frac{3}{4}$ -2.9 $-1\frac{3}{4}$

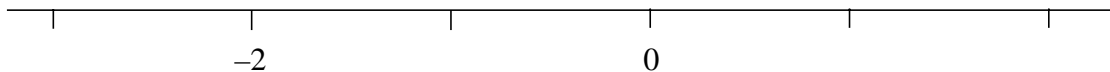

3) Write down the following numbers in order of size, smallest first

-6, 5, 26, -13, 1, -1, 0, and -12

4) Write down the following numbers in order of size, smallest first

-1.3, 1.8, $-\frac{1}{2}$, 2, -6, $2\frac{3}{4}$, 0, 3.1, $-4\frac{1}{4}$

Exercise 2

Calculate the final temperature, if

- | | |
|-------------------------|--------------------------|
| 1) 5°C increases by 9°C | 2) 5°C falls by 3°C |
| 3) 12°C falls by 15°C | 4) -2°C increases by 4°C |
| 5) -5°C falls by 8°C | 6) 9°C falls by 4°C |
| 7) -8°C falls by 12°C | 8) -4°C increases by 2°C |
| 9) 8°C falls by 12°C | 10) -6°C falls by 5°C |

Exercise 3

What is the change in temperature between each of the following?

- | | |
|------------------|-------------------|
| 1) 3°C and 7°C | 2) 17°C and 23°C |
| 3) -5°C and 4°C | 4) -7°C and 2°C |
| 5) -6°C and -3°C | 6) -7°C and 0°C |
| 7) 5°C and 2°C | 8) 7°C and -2°C |
| 9) 5°C and -3°C | 10) -2°C and -7°C |

Exercise 4

1) The table shows the temperatures at 4 towns in the United Kingdom on one day

	Perth	Llandudno	Norwich	Belfast
Midday	3	5	6	2
Midnight	-7	1	0	-1

- Which place had the lowest midday temperature?
 - Which place had the lowest midnight temperature?
 - Which place had the biggest change in temperature and by how much?
 - Which place had the least drop in temperature and by how much?
- At midnight the temperature was -10°C . At midday it had risen to 2°C . What was the change in temperature?
 - If the temperature falls from 5°C to -7°C , what is the change in temperature?
 - In a quiz, competitors get 2 marks for every correct answer, -1 for not answering and -2 for every incorrect answer. If three teams were given 20 questions each, calculate their scores and decide which team won. Team A answered 10 correct, 6 incorrect and failed to answer 4. Team B answered 11 correct and 9 incorrect.
Team C answered 11 correct, 7 incorrect and failed to answer 2.

8. Use of the Calculator 1

Exercise 1

Calculate each of the following pairs of problems. Predict the answers before you do them.

- | | | |
|----------------------|-----|---------------------|
| 1) $4 + 8 \div 4$ | and | $(4 + 8) \div 4$ |
| 2) $3 + 5 \times 4$ | and | $(3 + 5) \times 4$ |
| 3) $18 - 2 \times 3$ | and | $(18 - 2) \times 3$ |
| 4) $30 - 6 \div 2$ | and | $(30 - 6) \div 2$ |
| 5) $16 \div 4 + 4$ | and | $16 \div (4 + 4)$ |
| 6) $40 \div 8 + 2$ | and | $40 \div (8 + 2)$ |
| 7) $6 \times 4 + 2$ | and | $6 \times 4 + 2$ |

Exercise 2

Give your answer correct to 1 decimal place in each case.

- | | | |
|---------------------------------|-----------------------------------|--------------------------------------|
| 1) 0.34×0.54 | 2) 4.2×6.2 | 3) 15×3.67 |
| 4) $45 \div 13$ | 5) $12 \div 5$ | 6) $17.6 \div 3.1$ |
| 7) $3.54^2 + 5.46$ | 8) $4.17^2 + 13.4$ | 9) $8.3^2 - 19.7$ |
| 10) $4.11^2 + 5.39$ | 11) $5.32^2 + 12.1$ | 12) $6.7^2 - 23.4$ |
| 13) $\sqrt{35.41} - 3.62$ | 14) $\sqrt{18.45} + 12.6$ | 19) $\sqrt{23.7} - 3.5$ |
| 16) $\sqrt{43.12} - 4.75$ | 17) $\sqrt{24.6} + 15.8$ | 18) $\sqrt{37.1} - 5.21$ |
| 19) $3.54 + 4.26 - 3.87$ | 20) $13.3 - 5.78 + 4.89$ | 21) $8.88 + 4.32 - 6.853$ |
| 22) $13.44 - 4.76 + 4.56$ | 23) $22.3 + 5.99 + 3.66$ | 34) $14.54 + 5.33 - 8.54$ |
| 25) $\sqrt{45} - 5.36 + 2.45^2$ | 26) $6.49^2 - \sqrt{17.3} + 6.86$ | 27) $\sqrt{78} + \sqrt{23} - 2.35^2$ |

Exercise 3

Use your calculator to change these fractions into decimals. Give each answer correct to 2 decimal places.

- | | | | |
|-------------------------------------|------------------------------------|------------------------------------|-------------------------------------|
| 1) $\frac{1}{4} + \frac{3}{5}$ | 2) $\frac{1}{7} + \frac{1}{9}$ | 3) $\frac{2}{3} + \frac{3}{5}$ | 4) $\frac{3}{7} + \frac{1}{4}$ |
| 5) $\frac{3}{8} + \frac{5}{7}$ | 6) $\frac{5}{6} - \frac{1}{4}$ | 7) $\frac{1}{12} - \frac{1}{21}$ | 8) $\frac{1}{8} - \frac{1}{17}$ |
| 9) $\frac{3}{7} + \frac{5}{8}$ | 10) $\frac{1}{6} - \frac{1}{12}$ | 11) $\frac{1}{13} - \frac{1}{33}$ | 12) $\frac{1}{9} - \frac{1}{20}$ |
| 13) $\frac{3}{11} - \frac{5}{23}$ | 14) $\frac{7}{15} - \frac{5}{21}$ | 15) $3\frac{1}{4} + 2\frac{2}{3}$ | 16) $4\frac{1}{7} + 3\frac{1}{6}$ |
| 17) $5\frac{2}{3} + 1\frac{1}{5}$ | 18) $3\frac{4}{5} + 5\frac{1}{4}$ | 19) $2\frac{3}{8} + 5\frac{5}{7}$ | 20) $3\frac{5}{6} - 2\frac{1}{3}$ |
| 21) $4\frac{1}{12} - 3\frac{3}{16}$ | 22) $5\frac{1}{8} - 3\frac{3}{13}$ | 23) $4\frac{3}{8} - 2\frac{7}{13}$ | 24) $5\frac{5}{13} - 3\frac{3}{17}$ |

9 Use of the Calculator 2

Exercise 1

Calculate each of the following pairs of problems. Predict the answers before you do them.

- | | | |
|----------------------|-----|---------------------|
| 1) $3 + 6 \div 3$ | and | (3 + 6) \div 3 |
| 2) $2 + 3 \times 5$ | and | (2 + 3) \times 5 |
| 3) $12 - 4 \times 6$ | and | (12 - 4) \times 6 |
| 4) $20 - 4 \div 4$ | and | (20 - 4) \div 4 |
| 5) $20 \div 5 + 5$ | and | 20 \div (5 + 5) |
| 6) $35 \div 7 - 2$ | and | 35 \div (7 - 2) |
| 7) $3 \times 5 + 4$ | and | 3 \times (5 + 4) |

Exercise 2 (give your answer correct to 4 significant figures wherever necessary)

- | | |
|---|--|
| 1) $3.5 + 2.7 \div 4.1$ | 2) $2.5 - 1.4 \times 3.3$ |
| 3) $(3.4 - 2.1)3.6$ | 4) $2.5(7.4 + 2.3)$ |
| 5) $\frac{12.5 - 2.3}{2.5}$ | 6) $\frac{14.2 - 3.8}{1.7 - 0.4}$ |
| 7) $\frac{5.6 + 3.7}{3.4 + 7.3}$ | 8) $2.4 \div (3.4 - 2.2)$ |
| 9) $\frac{7.9 - 3.4^2}{2.5(3.2)}$ | 10) $6.4\left(\frac{2.2 + 1.4}{2.5}\right)$ |
| 11) $\frac{2.3 - 1.4}{3.1 \times 2.2}$ | 12) $\frac{3.5 + 4.2}{1.2 \times 3.2 - 1.4}$ |
| 13) $\frac{(4.6 - 3.5) \times 1.2}{1.2 + 2.3}$ | 14) $1.2\left(\frac{2.3 - 1.4}{3.1 \times 2.2}\right)$ |
| 15) $\frac{4.3^3 \times 3.1}{4.3 + 2.9}$ | 16) $4.7\left(\frac{5.4^2}{2.2 + 5.6}\right)$ |
| 17) $\frac{6.7^2 - 2.4 \times 3.3}{4.5 \times 3.2}$ | 18) $\frac{3.4 \div 2.3 \times 2.5}{3.4 \div 2.6}$ |
| 19) $\frac{5.7 - 4.2 + 1.45}{5.3 + 2.9}$ | 20) $\frac{7.9 + 3.4 - 2.3}{3.5(3.6 + 2.3)^2}$ |
| 21) $\frac{(4.5 - 3.8)^2 + 4.5}{4.5 - 3.2}$ | 22) $\frac{(4.7 + 2.54) \times 1.3}{6.5(3.1 + 2.5)}$ |
| 23) $\frac{(3.7 - 2.3) \div 1.4}{2.75(5.2 - 2.5)}$ | 24) $\frac{3.2((6.7 - 3.5) \div 2.4)}{6.5(3.4 - 3.1)^3}$ |

10. Types of Numbers

Exercise 1

1	2	3	4	5	6	7	8	9	10
11	12	13	14	15	16	17	18	19	20
21	22	23	24	25	26	27	28	29	30
31	32	33	34	35	36	37	38	39	40
41	42	43	44	45	46	47	48	49	50

From the list of numbers above, write down

- | | |
|--|------------------------------------|
| 1) The square of 5 | 2) The square root of 49 |
| 3) The largest prime number | 4) A multiple of 9 greater than 40 |
| 5) An even prime number | 6) All the factors of 48 |
| 7) All the cubic numbers | 8) A square, even number. |
| 9) A number which has 8 and 3 as two of its factors. | |
| 10) A number which has exactly 3 factors. | |

Exercise 2

Fill in the spaces in each of the following statements. Use a word from this list each time.

square root, square, prime, multiples, factors, prime, factors, not, cube root, cube, square, even, square.

- 1) The of 21 are 1,3,7 and 21.
- 2) The of 11 is 121.
- 3) 15, 20, 25, and 30 are all of 5.
- 4) 1, 4, 9, 16, 25 are numbers.
- 5) 2 is both the smallest number and the smallest number.
- 6) The numbers between 30 and 40 are 31 and 37.
- 7) 64 is the of 8 and the of 4.
- 8) The of 49 is three less than the of 1000.
- 9) 16 and 32 are both of 64.
- 10) 1 is ... a prime number.

Exercise 3

Without using a calculator, find the answer to each of these.

- | | | |
|---------------------------|----------------------------|----------------------------------|
| 1) $\sqrt{64}$ | 2) 4^2 | 3) 5^3 |
| 4) $3^2 + 2^3$ | 5) $\sqrt{49} - \sqrt{16}$ | 6) $\sqrt{81} \times \sqrt{100}$ |
| 7) $3^2 \times \sqrt{36}$ | 8) $\sqrt{64} - \sqrt{16}$ | 9) $8^2 - 4^2$ |
| 10) $5^3 \div 5^2$ | 11) $5^3 - 4^3$ | 12) $11^2 - \sqrt{144}$ |

Exercise 4

Each of the following statements are untrue. Explain why in each case.

- | | |
|--|--------------------------------|
| 1) 5 is a factor of 21 | 2) 27 is a multiple of 17. |
| 3) 44 is a prime number. | 4) 60 is a square number. |
| 5) $5^3 = 15$. | 6) The square root of 39 is 9. |
| 7) There is only one prime number between 40 and 50. | |
| 8) 9 is both a square number and a prime number. | |
| 9) 1 is not a factor of 100. | |
| 10) All prime numbers are odd. | |

11. Standard Form

Exercise 1

Write down these numbers in standard form

- | | | |
|--------------|-------------|------------|
| 1) 36 | 2) 426 | 3) 8300 |
| 4) 94 000 | 5) 562 000 | 6) 0.15 |
| 7) 0.0314 | 8) 0.0054 | 9) 0.00023 |
| 10) 0.000015 | 11) 0.00143 | 12) 157.3 |

Change these numbers from standard form.

- | | | |
|---------------------------|---------------------------|---------------------------|
| 13) 1.3×10^3 | 14) 3.4×10^4 | 15) 1.48×10^5 |
| 16) 2.1×10^7 | 17) 3.41×10^4 | 18) 4.32×10^6 |
| 19) 2.180×10^5 | 20) 9.36×10^{-3} | 21) 4.21×10^{-5} |
| 22) 5.97×10^{-4} | 23) 3.26×10^{-6} | 24) 4.85×10^{-5} |

Exercise 2

Calculate each of the following, leaving your answer in standard form. Round off to 4 significant figures where necessary.

- | | |
|---|--|
| 1) $(2.5 \times 10^2) \times (3.0 \times 10^4)$ | 2) $(4.6 \times 10^3) \times (2.8 \times 10^5)$ |
| 3) $(5.3 \times 10^{-2}) \times (2.4 \times 10^{-5})$ | 4) $(6.4 \times 10^{-4}) \times (3.7 \times 10^{-8})$ |
| 5) $(3.6 \times 10^4) \times (4.2 \times 10^{-2})$ | 6) $(4.81 \times 10^{-3}) \times (3.8 \times 10^7)$ |
| 7) $(5.4 \times 10^{10}) \div (2.7 \times 10^5)$ | 8) $(7.61 \times 10^6) \div (4.31 \times 10^{-2})$ |
| 9) $(8.31 \times 10^6) \div (4.36 \times 10^4)$ | 10) $(3.54 \times 10^{-4}) \div (5.36 \times 10^{-5})$ |
| 11) $\frac{5.7 \times 10^7}{45,000}$ | 12) $\frac{8.36 \times 10^7}{41,000}$ |
| 13) $\frac{(1.73 \times 10^6) \times (2.41 \times 10^5)}{3.17 \times 10^4}$ | 14) $\frac{(4.83 \times 10^{-7}) \times (4.61 \times 10^{-11})}{6.31 \times 10^4}$ |

Exercise 3

- If $x = 3 \times 10^5$ and $y = 2 \times 10^5$ write down the value of a) xy and b) $x + y$ leaving your answer in standard form.
- If $x = 3 \times 10^{-4}$ and $y = 3 \times 10^{-4}$ write down the value of a) xy and b) $x + y$ leaving your answer in standard form.
- If $x = 3 \times 10^{-5}$ and $y = 7 \times 10^{-3}$ write down the value of xy leaving your answer in standard form.
- The mass of the earth is 5.976×10^{24} kilograms and the mass of the moon is 7.35×10^{22} kilograms. Write down the ratio of the mass of the moon to that of the earth in the form $1 : n$.
- The distance of the moon from the earth is 384 400 kilometres. The speed of light is approximately 3.0×10^5 kilometres per second. How long does it take light to travel from the moon to the earth?
- A neutron has a mass of 1.675×10^{-27} kilograms and an electron 9.109×10^{-31} kilograms. Calculate the ratio of the mass of a neutron to the mass of an electron in the form $1 : n$.
- Light travels at a speed of approximately 3.0×10^5 kilometres per second. a) How far will it travel in 1 year (365 days)? b) If the distance from the earth to a star is 7.865×10^{13} kilometres, how long will its light take to reach earth?

12. Prime Factors

Do not use a calculator

Exercise 1

The prime factors of a number can be found by using a tree diagram. The example below shows how to find the prime factors of 36. In the same way find the prime factors of the other numbers.

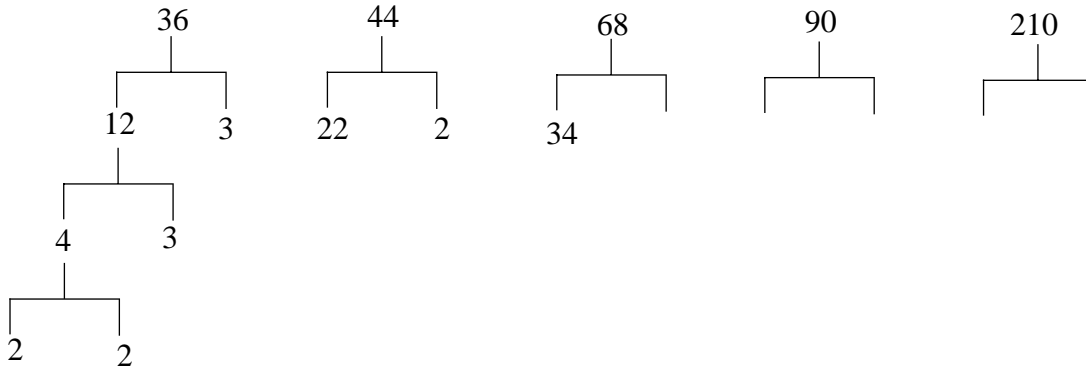

Exercise 2

Write down all the factors of the following numbers.

- | | | | | |
|--------|---------|---------|---------|---------|
| 1) 15 | 2) 20 | 3) 24 | 4) 30 | 5) 32 |
| 6) 40 | 7) 45 | 8) 60 | 9) 71 | 10) 84 |
| 11) 90 | 12) 100 | 13) 120 | 14) 130 | 15) 150 |

Exercise 3

Express the following numbers as products of their prime factors.

- | | | | | |
|----------|----------|----------|----------|----------|
| 1) 150 | 2) 160 | 3) 200 | 4) 210 | 5) 260 |
| 6) 675 | 7) 945 | 8) 1715 | 9) 1155 | 10) 1035 |
| 11) 1680 | 12) 1404 | 13) 1260 | 14) 2376 | 15) 1540 |

Exercise 4

Express the following numbers as products of their prime factors.

In each case state the smallest whole number it has to be multiplied by to produce a perfect square.

- | | | | | |
|---------|---------|---------|---------|----------|
| 1) 12 | 2) 18 | 3) 180 | 4) 80 | 5) 162 |
| 6) 252 | 7) 343 | 8) 468 | 9) 608 | 10) 980 |
| 11) 600 | 12) 360 | 13) 300 | 14) 192 | 15) 1850 |

Exercise 5

Calculate the largest odd number that is a factor of each of the following.

- | | | | | |
|----------|----------|----------|----------|----------|
| 1) 108 | 2) 180 | 3) 200 | 4) 271 | 5) 294 |
| 6) 504 | 7) 588 | 8) 720 | 9) 780 | 10) 468 |
| 11) 1248 | 12) 1200 | 13) 2160 | 14) 2520 | 15) 3920 |

13. Recurring Decimals

1) Without using a calculator, change the following fractions into recurring decimals.

a) $\frac{5}{9}$

b) $\frac{8}{9}$

c) $\frac{2}{9}$

d) $\frac{7}{9}$

e) $\frac{43}{99}$

f) $\frac{27}{99}$

g) $\frac{36}{99}$

h) $\frac{51}{99}$

Use a calculator to change these fractions into recurring decimals.

i) $\frac{122}{999}$

j) $\frac{542}{999}$

k) $\frac{418}{999}$

l) $\frac{74}{999}$

2) Which of the following fractions are equivalent to recurring decimals?

a) $\frac{5}{12}$

b) $\frac{52}{99}$

c) $\frac{7}{45}$

d) $\frac{3}{8}$

e) $\frac{11}{16}$

f) $\frac{97}{144}$

g) $\frac{43}{55}$

h) $\frac{31}{88}$

i) $\frac{5}{6}$

j) $\frac{7}{32}$

k) $\frac{41}{64}$

l) $\frac{63}{80}$

m) $\frac{541}{660}$

n) $\frac{6}{11}$

o) $\frac{63}{125}$

3) It is said that fractions with denominators that have prime factors of only 2 and 5 will represent terminating decimals.

For example $20 = 2 \times 2 \times 5$ so $\frac{1}{20} = 0.05$ $64 = 2 \times 2 \times 2 \times 2 \times 2 \times 2$ so $\frac{23}{64} = 0.359375$

Other fractions are represented by recurring decimals.

For example $15 = 3 \times 5$ so $\frac{1}{15} = 0.0\dot{6}$ $26 = 2 \times 13$ so $\frac{11}{26} = 0.4\dot{2}3\dot{0}7\dot{6}9$

Write down five fractions representing terminating decimals and five fractions representing recurring decimals. In each case write down both the fraction and the decimal.

4) Consider the number $0.\dot{2}\dot{3}\dot{4}$. Call this x

a) Write down the value of $0.\dot{2}\dot{3}\dot{4} \times 10$. Call this $10x$.

b) Write down the value of $0.\dot{2}\dot{3}\dot{4} \times 100$. Call this $100x$.

c) What is the value of $1000x$?

d) Subtract x from $1000x$ to get $999x$. Write down the value of $999x$?

e) What is $0.\dot{2}\dot{3}\dot{4}$ as a fraction?

5) Change each of the following recurring decimals into fractions in their lowest terms.

a) $0.\dot{1}\dot{3}$

b) $0.\dot{0}\dot{3}$

c) $0.\dot{2}\dot{0}$

d) $0.\dot{8}\dot{1}$

e) $0.\dot{0}\dot{5}$

f) $0.\dot{5}\dot{0}$

g) $0.\dot{6}\dot{1}$

h) $0.\dot{0}\dot{1}\dot{1}$

i) $0.\dot{5}\dot{1}\dot{8}$

j) $0.\dot{0}\dot{0}\dot{9}$

14. Fractions, Decimals and Percentages 1

Do not use a Calculator

Exercise 1

Change into decimals (correct to 4 decimal places where necessary)

- | | | | | | |
|---------------------|-------------------|-------------------|--------------------|---------------------|--------------------|
| 1) $\frac{3}{4}$ | 2) $\frac{5}{8}$ | 3) $\frac{2}{5}$ | 4) $\frac{3}{8}$ | 5) $\frac{5}{12}$ | 6) $\frac{7}{20}$ |
| 7) $\frac{8}{15}$ | 8) $\frac{7}{25}$ | 9) $\frac{3}{13}$ | 10) $\frac{4}{27}$ | 11) $\frac{14}{25}$ | 12) $\frac{8}{30}$ |
| 13) $\frac{11}{20}$ | 14) $\frac{3}{7}$ | 15) $\frac{5}{9}$ | 16) $\frac{7}{16}$ | 17) $\frac{8}{23}$ | 18) $\frac{9}{16}$ |

Exercise 2

Change these decimals into percentages

- | | | | | | |
|-----------|----------|----------|-----------|-----------|-----------|
| 1) 0.26 | 2) 0.34 | 3) 0.72 | 4) 0.87 | 5) 0.64 | 6) 0.35 |
| 7) 0.42 | 8) 0.961 | 9) 0.432 | 10) 0.614 | 11) 0.584 | 12) 0.826 |
| 13) 0.932 | 14) 0.3 | 15) 0.6 | 16) 1.9 | 17) 2.38 | 18) 6.41 |

Exercise 3

Change into percentages correct to 4 significant figures

- | | | | | | |
|---------------------|---------------------|---------------------|---------------------|----------------------|---------------------|
| 1) $\frac{4}{5}$ | 2) $\frac{8}{10}$ | 3) $\frac{7}{15}$ | 4) $\frac{3}{20}$ | 5) $\frac{9}{16}$ | 6) $\frac{5}{14}$ |
| 7) $\frac{10}{23}$ | 8) $\frac{24}{50}$ | 9) $\frac{18}{35}$ | 10) $\frac{12}{37}$ | 11) $\frac{25}{40}$ | 12) $\frac{15}{32}$ |
| 13) $\frac{18}{26}$ | 14) $\frac{27}{34}$ | 15) $\frac{81}{94}$ | 16) $\frac{41}{56}$ | 17) $\frac{81}{156}$ | 18) $\frac{57}{96}$ |

Exercise 4

Compare each of the following sets of numbers by first changing them into percentages.

Write them down in order of size, smallest to largest.

- | | | | | | |
|-------------------|------|-----|--------------------|------|-------|
| 1) $\frac{1}{4}$ | 0.2 | 23% | 2) $\frac{3}{8}$ | 0.41 | 36% |
| 3) $\frac{7}{8}$ | 0.8 | 87% | 4) $\frac{5}{16}$ | 0.3 | 31% |
| 5) $\frac{3}{20}$ | 0.14 | 10% | 6) $\frac{7}{16}$ | 0.47 | 43.7% |
| 7) $\frac{8}{23}$ | 0.35 | 30% | 8) $\frac{9}{17}$ | 0.47 | 47.3% |
| 9) $\frac{6}{28}$ | 0.2 | 21% | 10) $\frac{8}{31}$ | 0.25 | 25.6% |

Exercise 5

Copy each of the following diagrams into your book. Mark on them the approximate positions of the required numbers.

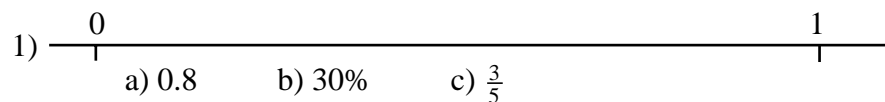
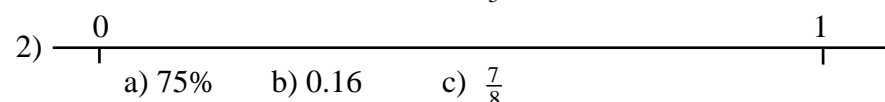
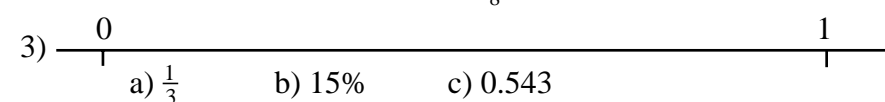
- 1) 
- 2) 
- 3) 

15. Fractions, Decimals and Percentages 2

Exercise 1

What fraction of the following shapes have been shaded in?

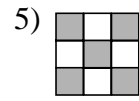
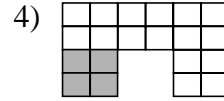
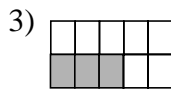
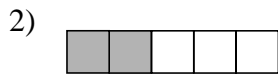
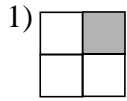

What percentage of the following shapes have been shaded in?

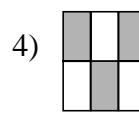
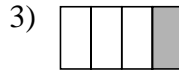
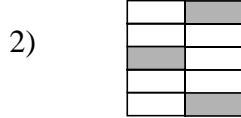
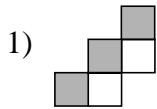

Exercise 2

Calculate

1) $\frac{3}{4}$ of 20

2) $\frac{3}{4}$ of 204

3) $\frac{7}{8}$ of £90

4) $\frac{5}{8}$ of £1.68

5) $\frac{5}{8}$ of 20 metres

6) $\frac{3}{4}$ of $12\frac{1}{2}$ metres

7) $\frac{5}{12}$ of £75

8) $\frac{7}{16}$ of 84m

9) $\frac{7}{30}$ of £66

10) $\frac{9}{16}$ of 4.4metres

11) $\frac{7}{8}$ of £44

12) $\frac{3}{10}$ of 7.7m

Exercise 3

Calculate

1) 37% of 600

2) 24% of 50

3) 36% of 950

4) 41% of 500

5) 15% of £6

6) 40% of £1.50

7) 60% of £19

8) 17% of 8 metres

9) 24% of £9

10) 72% of £4.50

11) 52% of £16.50

12) 93% of 1200

Exercise 4

Change these marks into percentages. (Give your answer correct to the nearest whole number)

1) 24 out of 50

2) 38 out of 60

3) 27 out of 40

4) 37 out of 80

5) 56 out of 90

6) 97 out of 150

7) 43 out of 200

8) 63 out of 70

9) 84 out of 120

10) 156 out of 250

11) 17 out of 20

12) 76 out of 110

13) 43 out of 76

14) 58 out of 95

15) 62 out of 68

16) 27 out of 45

Exercise 5

1) A car travels to London, a distance of 200 miles. 60 miles of this is on the motorway.

What fraction of the whole journey is on the motorway?

2) A cake weighs 800 grams. If 450 grams of this is flour, what fraction of the cake is flour?

3) David earns £200 a week. He pays £60 in tax. What fraction of his wages does he pay in tax and what is this as a percentage?

4) $\frac{2}{5}$ of the cost of a washing machine goes to the manufacturer. If a washing machine costs £250, how much does the manufacturer get?

5) Ben earns £200. If 15% of this is tax, how much tax does he pay?

16. Fractions, Decimals and Percentages 3

- 1) Liam earns £120 per week. If he gets a rise of 10%, what is his new wage?
- 2) A fridge normally costs £180. In a sale its price is reduced by $\frac{1}{5}$. What is its new price?
- 3) A house was on sale for £60,000. The owner decided to lower it by 7%. What is the new price?
- 4) The basic model of a car will travel 40 miles on a gallon of petrol. The de luxe version will travel $\frac{1}{8}$ further. How far will the de luxe car travel on a gallon of petrol?
- 5) Due to the bad summer weather, a farmer says that her potato crop will be $\frac{2}{5}$ lower than last year. She harvested 55 tonnes last year. What will it be this year?
- 6) It is expected that the number of new pupils at Clintster Community College will be 15% up on last year. 180 pupils started last year. How many are expected this year?
- 7) Sales of a magazine were 30,000 last week. They are expected to be $\frac{1}{4}$ higher this week. Approximately how many will be sold?
- 8) Packets of seeds normally contain 60 seeds. The new packets say ' $\frac{2}{3}$ extra free' on them. How many will now be in each packet?
- 9) The population of a town was 56,000 last year. It is expected to increase by 6% this year. What will the new population be?
- 10) 20% of a box of oranges are unfit to be sold. If the box contains 150 oranges, how many will be sold?
- 11) VAT (value added tax) of 6% is added to an electricity bill. How much is the total bill when £60 of electricity is used?
- 12) VAT is added onto the cost of work done by a plumber at a rate of $17\frac{1}{2}\%$. What is the total bill for £40 of work?
- 13) A solid bar of metal is cut into the shape of a tube. In doing this the bar loses $\frac{5}{9}$ of its weight. What will the tube weigh if the bar weighed 720 grammes?
- 14) In a sale the price of a shirt was reduced by $\frac{1}{3}$. If its original price was £12.60, what was the new price, correct to the nearest penny?
- 15) VAT of $17\frac{1}{2}\%$ is added to the price of a computer. If its original price was £725 calculate the price, including tax, correct to the nearest penny.
- 16) The height of a plant is 15cm on Monday. By Friday it has increased in height by $\frac{7}{10}$. What is its new height?
- 17) The telephone company says that my bill will go down by $\frac{3}{20}$ if I subscribe to their new system. What will my next bill be if my last one was £34.56, correct to the nearest penny?

17. Fractions, Decimals and Percentages 4

Exercise 1

Find the selling price for each of these.

	Buying Price	
1)	£100	17% profit
2)	£200	21% profit
3)	£150	20% profit
4)	£2000	15% profit
5)	£4200	32% profit
6)	£200	7.5% loss
7)	£70	25% loss
8)	£49,000	15% loss
9)	£80	27% loss
10)	£450	22% loss

Exercise 2

Find the percentage profit on each of the following, correct to the nearest whole number..

	Buying Price	Selling Price
1)	£100	£120
2)	£50	£80
3)	£60	£80
4)	£1.50	£1.80
5)	£2.80	£3.10
6)	£1,500	£1,700
7)	£45,000	£47,000
8)	£42.50	£45.00
9)	£900	£950
10)	£2010	£2500

Exercise 3

Calculate the simple interest on each of the following. Wherever necessary give your answer correct to the nearest penny.

- 1) £100 invested for 2 years at 2% interest per annum.
- 2) £150 invested for 2 years at 12% interest per annum.
- 3) £500 invested for 3 years at 9% interest per annum.
- 4) £1000 invested for 4 years at 10% interest per annum.
- 5) £1500 invested for 3 years at 7% interest per annum.
- 6) £2000 invested for 3 years at 4% interest per annum.
- 7) £5200 invested for 4 years at 5% interest per annum.
- 8) £120 invested for 2 years at 7% interest per annum.
- 9) £550 invested for 3 years at 8% interest per annum.
- 10) £2100 invested for 4 years at 6% interest per annum.

18. Interest

Exercise 1

Find the simple and compound interest (without using the compound interest formula) on each of the following. Wherever necessary give your answer correct to the nearest penny or cent.

- 1) £500 invested for 3 years at 4% interest per annum.
- 2) £250 invested for 3 years at 6% interest per annum.
- 3) £600 invested for 2 years at 10% interest per annum.
- 4) £1500 invested for 3 years at 8% interest per annum.
- 5) £2500 invested for 2 years at 4% interest per annum.
- 6) £3500 invested for 5 years at 6% interest per annum.
- 7) 7400 invested for 4 years at 3% interest per annum.
- 8) 3340 invested for 3 years at 3% interest per annum.
- 9) 6500 invested for 4 years at 5% interest per annum.
- 10) 1200 invested for 5 years at 4% interest per annum.

Exercise 2

The Compound Interest Formula is

$$x = P\left(1 + \frac{R}{100}\right)^n$$

Where x represents the amount in the bank after n years with a rate of $R\%$ on a principle of P .

- 1) Use the compound interest formula to calculate the amount of money in a bank account when
 - a) £3000 is invested for 6 years at a rate of 3%
 - b) £3000 is invested for 9 years at a rate of 3.4%
 - c) £14,500 is invested for 6 years at a rate of 4.7%
- 2) 10,000 Euros is invested in an account that pays interest at a compound rate of 5.1%
 - a) Calculate the value of $x = 1 + \frac{R}{100}$
 - b) By using the x^y key on your calculator, make a list of the amounts of money in the account at the end of each of the 6 years the money is left in the account.
- 3) Calculate the interest gained when 20,000 Euros is invested for 12 years in a bond which pays an interest of 4.2% per annum.
- 4) What is the difference between the simple and compound interest earned on an investment of £6000 over a period of 15 years at a rate of 3.54%?

19. Ratio and Proportion

Exercise 1

Divide each of the following into the ratios given.

- | | |
|-------------------------------|----------------------------------|
| 1) £900 into the ratio 4:5 | 2) £1000 into the ratio 3:7 |
| 3) £200 into the ratio 3:5 | 4) £600 into the ratio 7:8 |
| 5) £1200 into the ratio 5:7 | 6) £750 into the ratio 7:3 |
| 7) £800 into the ratio 5:11 | 8) £700 into the ratio 5:9 |
| 9) £630 into the ratio 7:11 | 10) £1265 into the ratio 9:14 |
| 11) £2205 into the ratio 8:13 | 12) £1170 into the ratio 4:5 |
| 13) £120 into the ratio 7:3:2 | 14) £450 into the ratio 5:6:7 |
| 15) £550 into the ratio 5:8:9 | 16) £13.86 into the ratio 3:7:11 |

Exercise 2

- 1) George and Lucy win £600 on the lottery. They decide to share it in the ratio 3:2.
How much will each receive?
- 2) A length of electric wire measuring 100 metres is cut into two pieces in the ratio 3:7.
How long is each piece?

- 3) The ratio of squares shaded in to those not shaded in is 1:2
How many more need to be shaded to make the ratio 2:1?

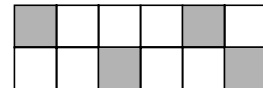

- 4) Liam makes some chocolate buns. The recipe below will make 8 buns.

50 g of butter
150 ml of water
60g of flour
6 eggs
170g chocolate

- a) Liam wants to make 12 buns. How much of each ingredient will he need?
- b) Last week Liam's mum made 30 buns. How much of each ingredient did she use?
- 5) An amount of money was shared between two brothers in the ratio 5:4. The first brother gets £200. a) How much did the second brother get? b) How much money was there altogether?
- 6) In a school there are 950 pupils. The ratio of boys to girls is 13:12. How many boys and how many girls are in the school?
- 7) A newsagent knows that for every 5 copies of a gardening magazine she sells she also sells 8 copies of a TV magazine. If she sells 100 gardening magazines, how many TV magazines does she sell?

- 8) The ratio of the shaded squares to the unshaded ones in this diagram is 1 : 4. How many more squares need to be shaded to make the ratio 2 : 1?

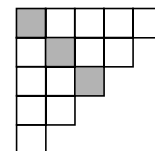

- 9) 15 shortbread biscuits can be made from the following recipe

105g of butter
45g caster sugar
180g plain flour

Re-write the recipe for 25 biscuits.

- 10) An alloy is made of copper, tin and lead in the ratio 12:5:3.
Calculate how much of each metal is in 800g of the alloy.
- 11) Three friends buy 6 lottery tickets between them. Amy pays £3, Bethan pays £2 and Charlotte pays £1. They agree to share their winnings in the ratio of their stakes.
If they win £24,000 how much do they each get?

20. Personal and Household Finance

- 1) On a market stall, apples are sold at 8 for £1.12. On another stall the same apples are sold at 12 for £1.92. Which stall is selling them cheapest?
- 2) Davids bill at the grocery shop was

Cat food 98p	6 eggs 80p	Margarine 62p	Milk 77p
--------------	------------	---------------	----------

 - a) What was his total bill?
 - b) What was his change from a £5 note?
- 3) Sarah goes to the post office to buy as many stamps as she can for £5. She buys stamps costing 26p each. She uses a £5 note. How many does she buy and how much is left over?
- 4) Craig goes to a cafe with his mum, dad and sister. This is what they buy

2 cups of coffee at 63p each	4 sandwiches at 97p each	2 colas at 53p each.
------------------------------	--------------------------	----------------------

 - a) What was their total bill?
 - b) What was their change out of a £10 note?
- 5) A CD player costs £35 deposit and 12 monthly instalments of £7.45. What is its total cost?
- 6) Harry gets £4.50 pocket money a week. He also does a paper round for which he gets paid £9.50 per week. He saves all his money each week in order to buy a camera. If the camera costs £150, for how many weeks will she have to save?
- 7) Shirts are sold at £9.50 each or 3 for £25. How much is saved by buying 3 shirts?
- 8) For her small business, Jill bought a computer for £699.95, a printer for £149.95 and a scanner for £99.95. What was her total bill?
- 9) Daniel's Mum bought packets of balloons for his birthday party. If they cost 49p a packet, how many packets did she buy with a £5 note? How much change did she get?
- 10) Mrs Brown's electricity bill showed that she used 1328 units. The cost of her bill was made up of a standing charge of £8.47 and the units at cost 7p each. What was her total bill?
- 11) A TV costs £105 deposit and 20 weekly payments of £5.37. What is the total cost?
- 12) CD's cost £2.99 each or 4 for £10. How much money is saved by buying 4?
- 13) Sarah is making a shelf for her bedroom. She buys 3 brackets costing 55p each, a packet of screws and plugs costing 95p and a piece of wood for £3.30. What is the total cost of the shelf and what is her change from a £10 note?
- 14) Joe buys petrol for his car. It costs 67p per litre. He buys £10 worth. How many litres is it?
- 15) A gas bill shows the following information. Complete the bill by filling in the blanks.

Present meter reading	0964
Previous meter reading	0872
Units used
Cost of each unit	41p
Cost of units used
Standing charge	£8.12
Total cost of bill
- 16) Mr Patel's council tax bill for the year is £784.80. He pays in 12 equal monthly instalments. How much per month will he pay?
- 17) Megan and her family go to town on the train. Tickets cost £3.35 single or £5.45 return for an adult and £1.95 single or £3.35 return for a child. There is one adult and 3 children in the family. How much money is saved by buying return tickets?
- 18) David buys 21p stamps and 28p stamps from the post office, with a £5 note. If he buys 14 stamps at 21p, how many stamps at 28p can he buy?
- 19) Cinema tickets normally cost £4.20, but are £2.80 before 5.00pm. How much is saved if a group of 6 people go before 5.00pm?

21. Tables

1) The timetable below shows when the bus leaves the Town Hall and arrives at Apple Way.

Town Hall	0730	0800	0815	0830	0845	0900	Then every 30	1800	1900
Apple Way	0752	0822	0837	0852	0907	0922	minutes until	1822	1922

- a) At what time does the 0815 from the Town Hall arrive a Apple Way?
- b) At what time will the 0930 from the Town Hall arrive at Apple Way?
- c) How long does the 1200 from the Town Hall take to get to Apple Way?
- d) If the 1630 from the Town Hall is late by 16 minutes because of a traffic hold up, at what time does it arrive at Apple Way?

2) The table shows the cost of a 1 week holiday in New York.

Accommodation	2 Star	3 Star	4 Star	5 Star
20 Mar - 30 Apr	649	689	799	909
01 May - 30 Jun	759	765	919	1029
01 Jul - 31 Aug	839	899	1009	1119
01 Sept - 31 Oct	769	819	929	1039
01 Nov - 12 Dec	659	699	809	919
13 Dec - 24 Dec	859	919	1029	1139
25 Dec - 31 Dec	659	699	809	919

Calculate

- a) The cost of a holiday for 1 person in a 5 star hotel leaving on 2nd July
- b) The cost of a holiday for 2 people in a 4 star hotel leaving on 2nd December
- c) The cost of a holiday for a family of four in a two star hotel, leaving on 17th August.

3) The table shows the evening programmes on television

6.00 Six O'clock News	9.50 Local News
7.00 Holiday Show	10.00 Main Evening News
7.30 Cartoon	10.30 Antiques Show
7.40 The Music Programme	11.00 Nature Programme
8.10 Film	11.25 Late Night Show

- a) How long does 'The Music Programme' last?
- b) How long does the film last?
- c) Claire has a 3 hour video tape. She records the film and the 'Antiques Show'. Will she have enough space left on the tape to record the 'Nature Programme'?

4)

Cardiff						
Edinburgh	373					
Glasgow	370	45				
London	154	386	403			
Manchester	172	213	214	189		
Newcastle	298	105	142	281	132	
Swansea	45	380	381	192	183	314
	C	E	G	L	M	N

The table shows the distances between some cities in Britain. The distance between London and Cardiff is highlighted.

- What is the distance between a) Swansea and Glasgow? b) Newcastle and London?
Which towns are closest to each other?

22. Conversion Graphs 1

- 1) The graph can be used to convert euros (€) into Canadian dollars. Use it to convert;
- 5.50 into Canadian dollars.
 - 10 dollars into euros and cents.
 - How many dollars and cents are equal to 1 euro?

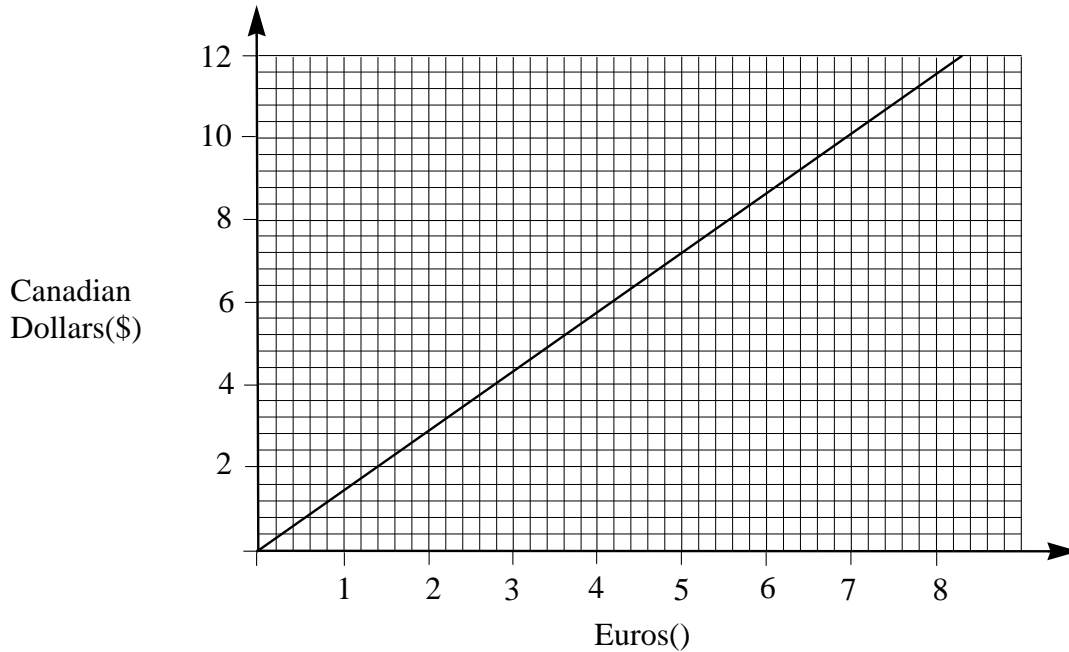

- 2) The graph can be used to convert pounds (£) into Japanese yen. Use it to convert;
- £12 into yen.
 - 1500 yen into pounds.
 - What is the approximate value of £1 in yen?

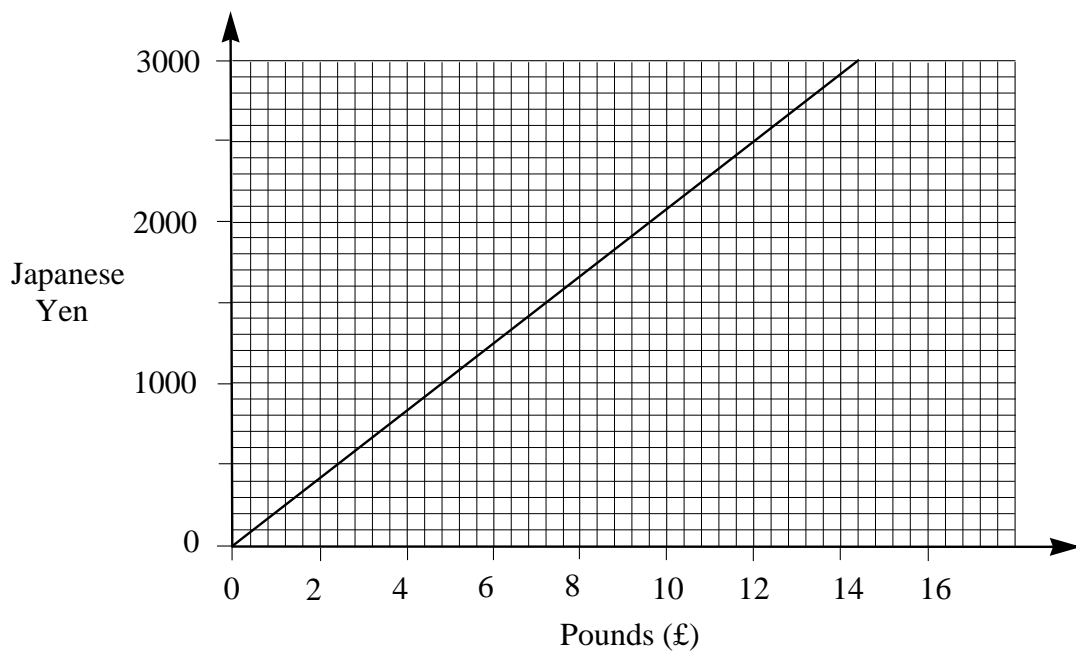

23. Conversion Graphs 2

- 1) 1 inch is approximately 2.54 centimetres. Calculate what 100 inches is in centimetres.

From this information draw a graph to convert inches into centimetres.

Use a horizontal scale of 4cm to represent 40 inches and a vertical scale of 4cm to represent 80cm.

Plot 0cm = 0 inches and the value for 100 inches.

Join up the two points for your graph.

From your graph convert;

- a) 75 inches into centimetres.
- b) 100 centimetres into inches.

- 2) It is known that 1 mile is approximately equal to 1.6 kilometres.

Use this information to change 100 miles into kilometres

Plot a graph to convert miles into kilometres.

Use a scale of 2cm to represent 20 miles on the horizontal axis and 2cm to represent 20 kilometres on the vertical axis.

Plot 0 miles = 0 kilometres and the value for 100 miles

Join up the two points for your graph.

From your graph; a) convert 90 miles into kilometres

b) convert 80 kilometres into miles

In each case give your answer correct to the nearest unit.

- 3) The table below shows the value of New Zealand dollars in pounds.

Dollars	\$14.85	\$35.64	\$60	\$75
Pounds	£5	£12	£20.20	£25.25

Use this information to plot a conversion graph with a scale of 4cm to represent £10 on the horizontal axis and 2cm to represent \$10 on the vertical axis.

From your graph find;

- a) The value of £15 in dollars
- b) The number of pounds that can be exchanged for 65 dollars.

- 4) A swimming pool holds 18,000 gallons of water, which is approximately the same as 82,000 litres.

Draw a graph to convert gallons into litres.

Use a scale of 1cm to represent 1000 gallons on the vertical axis and 1cm to represent 5000 litres on the horizontal axis.

From your graph find

- a) The number of litres of water in a pool holding 10,000 gallons.
- b) The number of gallons in a pool having a capacity of 50,000 litres

24. Distance Time Diagrams 1

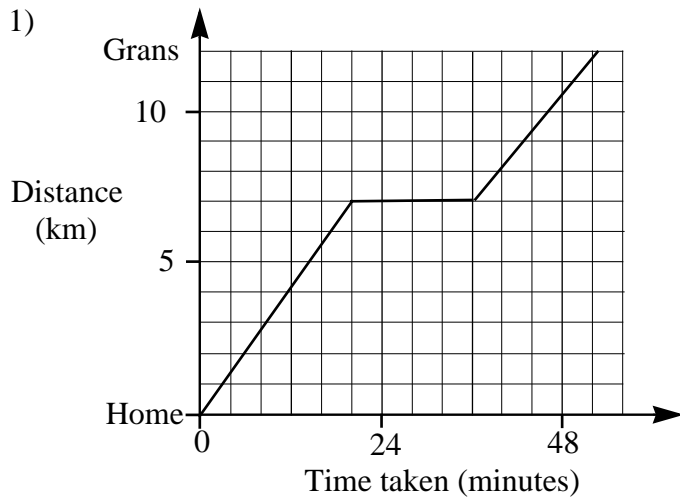

Every Saturday morning Debbie visits her gran. She has to get two buses to get there. The diagram shows the journey,

- a) What is the distance between her home and her gran's?
- b) How long did she wait for the second bus?
- c) What was the average speed of the first bus in km/hr?
- d) What was the average speed of the second bus?

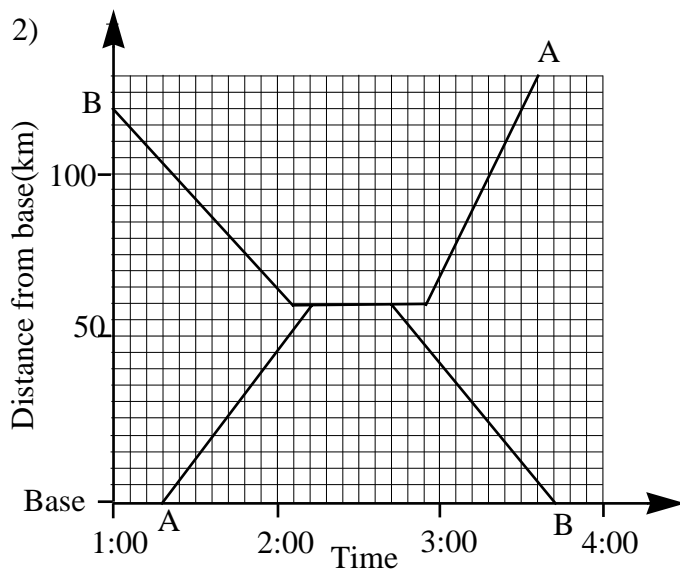

Two lorries travel down the motorway in opposite directions. The drivers plan to meet up at the same service station. The diagram shows their journey.

- a) Who arrives at the service station first A or B?
- b) How long does A stay at the service station?
- c) How long does B stay?
- d) For how long are they together at the service station?
- e) Who is the faster driver?

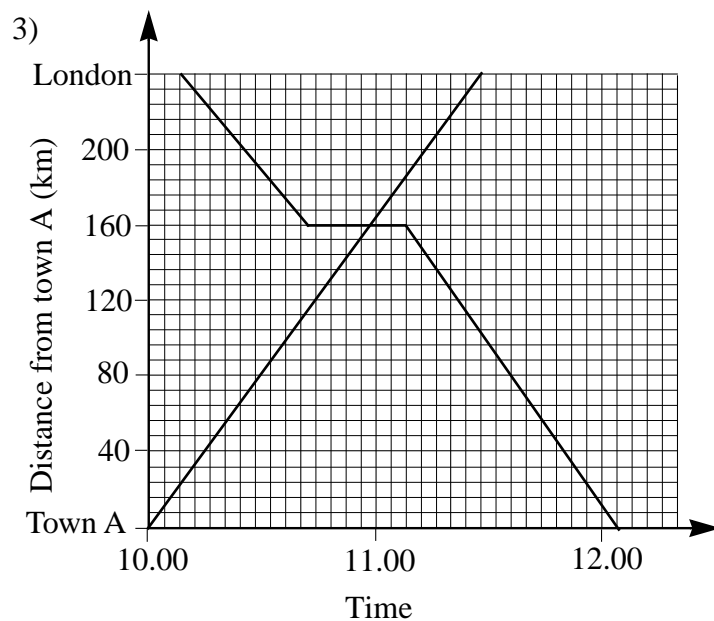

Two people travel by train. The first travels from town A to London, the other from London to town A.

On the journey from London the passengers have to change trains at town B. The diagram shows the journey.

- a) How far from London is town B?
- b) How long do passengers wait at town B?
- c) What is the average speed of the train to London?
- d) How many minutes faster is the journey to London compared to the journey from London?

25. Distance Time Diagrams 2

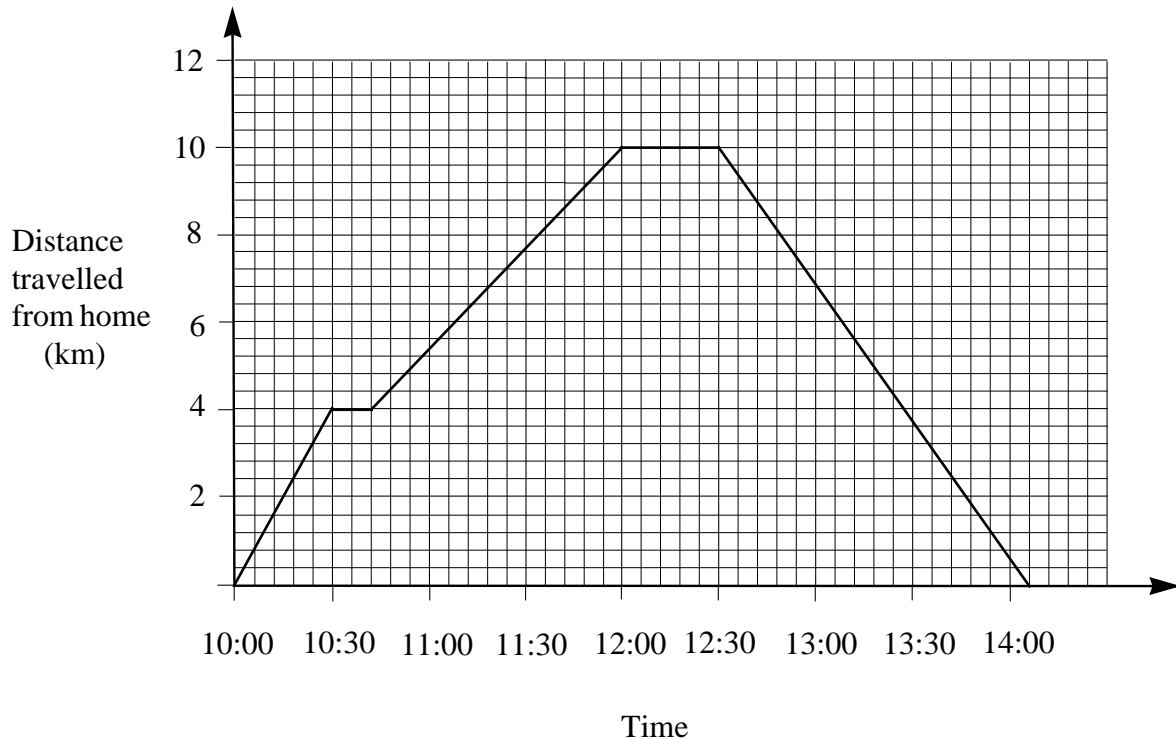

The diagram shows a distance-time graph for a jogger.

The jogger stopped twice on her journey, once on the outward journey and at the end of the outward journey.

- For how long was the first stop?
- What is the average speed on the part of the journey before the first stop?
- How long did it take to travel the first 10km?
- What is the average speed of the jogger on her homeward journey?
- For how long did the jogger stop altogether?
- At what time did she arrive home?
- What part of the journey was fastest? Explain your answer.

A second jogger does the same journey. He begins at 11:00 and travels at a constant pace of 8km/hr until he stops at the half way mark for 12 minutes. He then travels home at a constant pace of 7km/hr.

- Show this journey on the diagram.
- Who arrived home first?
- At what time did the second jogger arrive home?
- How many minutes apart were their finish times?

26. Trial and Improvement 1

- 1) A farmer buys some cows and sheep. Cows cost £300 each and sheep cost £50 each. She buys 7 animals altogether. She spends £1100. Use a trial and improvement method to calculate how many of each animal she buys.
- 2) An antiques dealer buys some tables and chairs. Tables cost £150 each and chairs cost £40 each. She buys 15 items of furniture at a cost of £930. Use a trial and improvement method to calculate how many chairs were purchased.
- 3) Harry buys some stamps costing 26p each and some costing 20p each. He spends £1.18 and buys 5 stamps. Use a trial and improvement method to calculate how many of each he buys.
- 4) Olivia buys some stamps costing 30p each and some costing 25p each. She spends £4.75 and buys 17 stamps. Use a trial and improvement method to calculate how many of each she buys.
- 5) Pencils cost 15p each and pens cost 10p each. Karen buys 11 items at a total cost of £1.30. Use a trial and improvement method to calculate how many of each she buys.
- 6) Pencils cost 12p each and pens cost 14p each. James buys 16 items at a total cost of £2.10. Use a trial and improvement method to calculate how many of each he buys.

- 7) Buttons are sold on cards of four or six. John bought 62 buttons on 13 cards. Use a trial and improvement method to calculate how many of each card he bought.

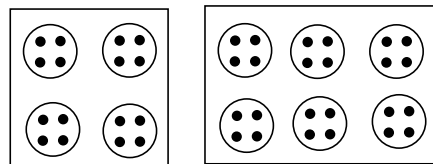

- 8) Shirt buttons are sold on cards of 5 and 12. Sarah buys 83 buttons on 11 cards. Use a trial and improvement method to determine how many of each type of card she buys.
- 9) A square has an area of 69cm^2 . Use a trial and improvement method to calculate the length of one side, correct to the nearest millimetre.

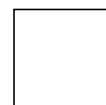

- 10) Another square has an area of 84 cm^2 . Use a trial and improvement method to calculate the length of one side, correct to the nearest millimetre.

- 1) A rectangle has an area of 50cm^2 . If the length is 2cm longer than the width, calculate its width, correct to the nearest millimetre.

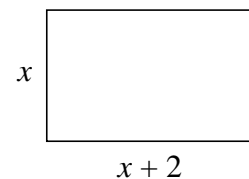

- 12) Another rectangle has an area of 37 cm^2 . The length is 3 cm longer than the width. Use a trial and improvement method to calculate the length of the rectangle, correct to the nearest millimetre.

27. Trial and Improvement 2

Exercise 1

Calculate the value of x , correct to 1 decimal place for each of the following, using a trial and improvement method. Show all your attempts.

1) $x^3 = 41$

2) $x^3 = 57$

3) $x^3 = 86$

4) $x^3 = 97$

5) $x^3 = 132$

6) $x^3 = 77$

7) $x^3 = 60$

8) $x^3 = 117$

9) $x^3 = 142$

Exercise 2

By using a suitable trial and improvement method find the value of x , correct to one decimal place, which satisfies each of the following equations. Show all your attempts.

1) $x^2 + x = 23$

2) $x^2 + x = 37$

3) $x^2 - x = 45$

4) $x^2 - 4x = 49$

5) $x^2 + 3x = 23$

6) $x^2 + 5x = 32$

7) $x^2 - 2x = 41$

8) $x^2 - 4x = 57$

9) $x^3 + x = 67$

10) $x^3 + 2x = 55$

11) $x^3 - x = 67$

12) $x^3 - 3x = 100$

13) If $x^2 = 30$, find the value of x correct to 1 decimal place.

14) If $x^2 + x = 27$, what is the value of x correct to 1 decimal place?

15) Calculate the value of x in the equation $x^2 + 3x = 36$, correct to one decimal place.

16) Solve the equation $x^3 - 3x = 40$, correct to 1 decimal place.

17) A square has an area of 32cm^2 . Use a trial and improvement method to calculate the length of one side.

18) The longer side of a rectangle is 3 cm greater than the shorter side. If its area is 24cm^2 use a trial and improvement method to calculate the size of the shorter side?

19) The perpendicular height of a right angled triangle is 5cm more than its base. If its area is 92cm^2 , what is the length of its base.

20) A cuboid has a height and length which are each 6cm greater than its width. If its volume is 600cm^3 , calculate its width correct to one decimal place.

28. Number Patterns and Sequences 1

Exercise 1

In each of the following patterns write down the next two numbers

- | | | |
|---------------------------|-----------------------------|----------------------------|
| 1) 2, 4, 6, 8, 10.... | 2) 5, 7, 9, 11, 13.... | 3) 7, 10, 13, 16, 19.... |
| 4) 5, 9, 13, 17, 21.... | 5) 3, 8, 13, 18, 23.... | 6) 3, 12, 21, 30, 39.... |
| 7) 3, 4, 6, 9, 13.... | 8) 5, 5, 6, 8, 11.... | 9) 5, 7, 11, 17, 25.... |
| 10) 2, 3, 5, 8, 12.... | 11) 20, 21, 23, 26, 30.... | 12) 3, 5, 8, 12, 17.... |
| 13) 15, 13, 11, 9, 7.... | 14) 20, 20, 19, 17, 14.... | 15) 22, 19, 16, 13, 10.... |
| 16) 15, 13, 10, 6, 1.... | 17) 7, 5, 3, 1, -1.... | 18) 8, 8, 7, 5, 2.... |
| 19) 5, 2, -2, -7, -13.... | 20) -1, -2, -4, -7, -11.... | 21) -2, 1, 4, 7, 10.... |

Exercise 2

In each of the following patterns (a) write down the next two numbers, (b) Explain in words how you would find the eighth number.

- | | | |
|----------------------------|-----------------------------|------------------------------|
| 1) 1, 2, 4, 11, 16.... | 2) 0, 2, 9, 14, 20.... | 3) 1, 1, 2, 4, 7, 11.... |
| 4) 1, 1, 2, 3, 5, 8... | 5) 2, 4, 8, 16, 32, 641... | 6) 1, 4, 7, 10, 13, 16.... |
| 7) 1, 3, 7, 15, 31, 63.... | 8) 1, 3, 9, 27, 81, 243.... | 9) 128, 64, 32, 16, 8, 4.... |

Exercise 3

In each of the following patterns (a) write down the next two numbers, (b) Write down in words the rule for finding the next number and (c) write down the rule for finding the n^{th} number in the pattern.

- | | | |
|-------------------------|---------------------------|---------------------------|
| 1) 1, 3, 5, 7, 9.... | 2) 2, 5, 8, 11, 14.... | 3) 5, 9, 13, 17, 21.... |
| 4) 6, 12, 18, 24, 30... | 5) 7, 13, 19, 25, 31.... | 6) 12, 17, 22, 27, 32.... |
| 7) 3, 5, 7, 9, 11.... | 8) 0, 3, 6, 9, 12, 15.... | 9) 11, 16, 21, 26, 31.... |

Exercise 4

1) The diagrams below show how some patterns have been made up with strips of square tiles.



1 Strip



2 Strips

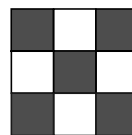

3 Strips



4 Strips

- How many dark tiles will there be in 5 strips?
- Explain in words how the number of dark tiles is changing each time.
- Explain how the number of white tiles is changing each time.

2) The diagrams below show square 'holes' surrounded by centimetre squares.

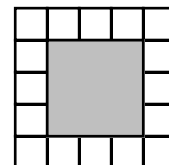
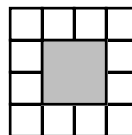
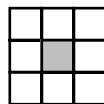

Length of side	1	2	3
Number of squares	8	12	16

- Find the number of squares needed for holes of side a) 4cm b) 5cm c) n cm
- d) Calculate the number of squares needed for a hole of side 20cm.

29. Number Patterns and Sequences 2

1) A child places blocks on a floor making the pattern shown below. The first row contains 1 block, the second 3 blocks, the third 5 and so on.

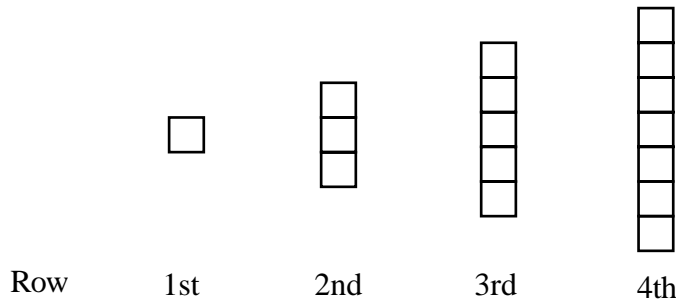

How many blocks will be in a) row 5 b) row 6 c) row n
 d) Calculate how many will be in row 40.

2) The diagram shows a number of rectangles where the length is 1 unit longer than the width.

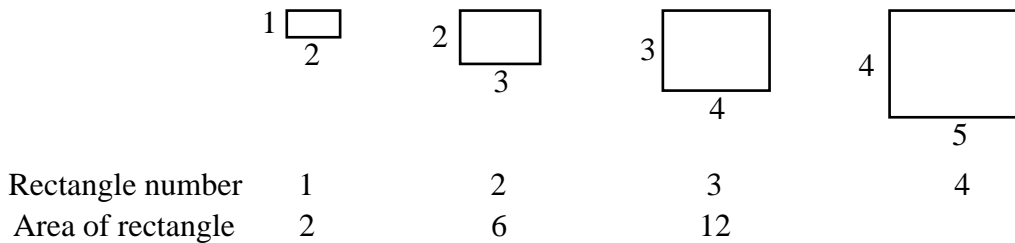

Find the areas of a) Rectangle 4 b) Rectangle 5
 c) What do you add on to the area of rectangle 5 to get rectangle 6?

3) A library shelving system is made from uprights and shelves as shown below.

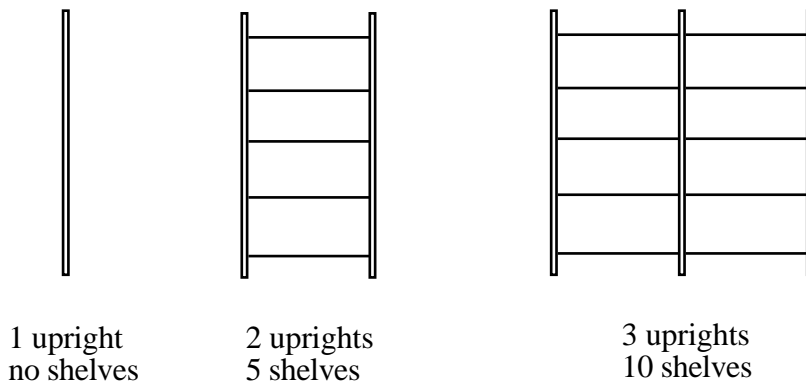

How many shelves can be made from a) 4 uprights b) 5 uprights c) n uprights.
 d) How many shelves are needed for 10 uprights.

4) Shapes are made from matchsticks as shown below.

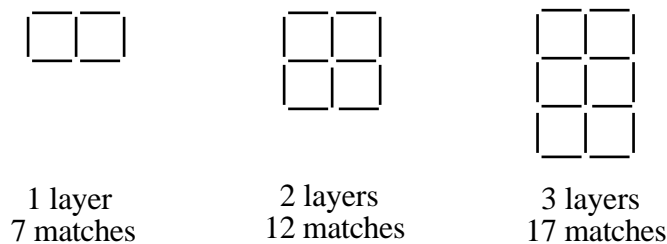

Write down the number of matches needed for shapes with a) 4 layers b) 5 layers c) n layers
 Calculate the number of matches needed for a shape having 12 layers.

30. Indices

Exercise 1

Write down the values of the following.

- 1) 2^2 2) 2^3 3) 4^3 4) 5^3 5) 7^2 6) 8^3 7) 5^4

Exercise 2

Use a calculator to write down the values of the following.

- 1) 10^2 2) 10^3 3) 10^4 4) 10^5 5) 12^3 6) 13^2 7) 20^4

Exercise 3

Write down the answers to these both in index form and, where necessary, numerical form.

- 1) $2^2 \times 2^2$ 2) $2^3 \times 2^3$ 3) $2^4 \times 2^5$ 4) $3^2 \times 3^2$ 5) $4^4 \times 4^5$
 6) $2^3 \times 2^2 \times 2^3$ 7) $3^2 \times 3^2 \times 3^2$ 8) $4^2 \times 4^3 \times 4^5$ 9) $5^2 \times 5^3 \times 5^3$ 10) $7^3 \times 7^2 \times 7^2$
 11) $a^3 \times a^2$ 12) $b^4 \times b^3$ 13) $c^4 \times c^2 \times c^5$ 14) $x^3 \times x^3 \times x^4$ 15) $y^4 \times y^6 \times y^7$

Exercise 4

Write down the answers to each of the following in index form.

- 1) $2^4 \div 2^2$ 2) $4^5 \div 4^3$ 3) $5^7 \div 5^5$ 4) $6^8 \div 6^4$ 5) $7^6 \div 7^3$ 6) $9^9 \div 9^6$
 7) $\frac{2^5}{2^3}$ 8) $\frac{4^6}{4^3}$ 9) $\frac{7^7}{7^2}$ 10) $\frac{6^8}{6^4}$ 11) $\frac{10^9}{10^4}$ 12) $\frac{5^{12}}{5^5}$ 13) $\frac{8^{18}}{8^3}$
 14) $x^8 \div x^4$ 15) $y^6 \div y^3$ 16) $z^9 \div z^6$ 17) $\frac{x^8}{x^4}$ 18) $\frac{y^9}{y^4}$ 19) $\frac{z^7}{z^5}$ 20) $\frac{a^9}{a}$

Exercise 5

Write down the answers to each of the following in index form.

- 1) $(2^3)^2$ 2) $(3^4)^5$ 3) $(5^7)^4$ 4) $(7^{13})^2$ 5) $(12^8)^5$ 6) $(15^8)^5$
 7) $(a^4)^5$ 8) $(b^5)^5$ 9) $(c^6)^2$ 10) $(x^3)^8$ 11) $(y^7)^9$ 12) $(z^6)^4$

Exercise 6

Calculate the answers to each of these in numerical form.

- 1) $(2 \times 4)^3$ 2) $(3 \times 3)^5$ 3) $(5 \times 2)^3$ 4) $(3 \times 4)^4$ 5) $(3 \times 5)^5$
 6) $(2 \times 7)^3$ 7) $(6 \times 2)^2$ 8) $(7 \times 3)^4$ 9) $(4 \times 4)^2$ 10) $(5 \times 4)^3$

Exercise 7

Simplify each of the following

- 1) $3a^5 \times a^6$ 2) $b^4 \times 2b^5$ 3) $2x^6 \times 3x^5 \times x^4$ 4) $2y^2 \times 3y^2 \times 5y^3$
 5) $3x^8 \div x^4$ 6) $6y^6 \div 3y^3$ 7) $10z^9 \div 5z^6$ 8) $20z^5 \div 4z^2$
 9) $\frac{2x^8}{x^4}$ 10) $\frac{3y^9}{y^4}$ 11) $\frac{4z^7}{z^5}$ 12) $\frac{8a^9}{2a}$ 13) $\frac{12b^9}{2b^2}$
 14) $(2a^4)^2$ 15) $(3b^2)^3$ 16) $(4c^3)^2$ 17) $(3x^3)^3$ 18) $(2y^3)^4$

31. Number Machines

1) In each of the following number machines, say what the question mark represents.

- | | |
|--|--|
| a) $4 \longrightarrow \times 5 \longrightarrow ?$ | b) $5 \longrightarrow \times 3 \longrightarrow ?$ |
| c) $3 \longrightarrow \times ? \longrightarrow 21$ | d) $6 \longrightarrow \times ? \longrightarrow 42$ |
| e) $? \longrightarrow \times 8 \longrightarrow 48$ | f) $? \longrightarrow \times 5 \longrightarrow 35$ |
| g) $80 \longrightarrow \div 5 \longrightarrow ?$ | h) $48 \longrightarrow \div ? \longrightarrow 8$ |
| i) $? \longrightarrow \div 7 \longrightarrow 9$ | j) $? \longrightarrow \div 2.5 \longrightarrow 4$ |

2) In the following number machines, say what number comes out each time.

- a) Number in \longrightarrow $\boxed{\times 5}$ \longrightarrow $\boxed{+ 3}$ \longrightarrow Number out
 Numbers in are (i) 2 (ii) 7 (iii) -4
- b) Number in \longrightarrow $\boxed{\times 7}$ \longrightarrow $\boxed{- 4}$ \longrightarrow Number out
 Numbers in are (i) 3 (ii) 8 (iii) -1
- c) Number in \longrightarrow $\boxed{\div 2}$ \longrightarrow $\boxed{+ 5}$ \longrightarrow Number out
 Numbers in are (i) 6 (ii) 12 (iii) 0
- d) Number in \longrightarrow $\boxed{\div 6}$ \longrightarrow $\boxed{- 6}$ \longrightarrow Number out
 Numbers in are (i) 18 (ii) 42 (iii) -12

3) In the following number machines, write down an expression, in terms of n , for the rule.

- a) $n \longrightarrow$ $\boxed{\text{Multiply by 3}}$ \longrightarrow $\boxed{\text{Add 7}}$ \longrightarrow
- b) $n \longrightarrow$ $\boxed{\text{Multiply by 5}}$ \longrightarrow $\boxed{\text{Add 4}}$ \longrightarrow
- c) $n \longrightarrow$ $\boxed{\text{Multiply by 8}}$ \longrightarrow $\boxed{\text{Subtract 3}}$ \longrightarrow
- d) $n \longrightarrow$ $\boxed{\text{Divide by 6}}$ \longrightarrow $\boxed{\text{Add 9}}$ \longrightarrow
- e) $n \longrightarrow$ $\boxed{\text{Divide by 2}}$ \longrightarrow $\boxed{\text{Subtract 7}}$ \longrightarrow

32. Substitution 1

Exercise 1

- 1) Mohammed works every Saturday at the local supermarket. His wages are calculated using the following formula.

$$\text{Wages} = \text{Number of hours worked} \times \text{£}3.30$$

Calculate his wages if he works a) 8 hours b) $6\frac{1}{2}$ hours.

- 2) The cost of an electricity bill is calculated using the formula

$$\text{Cost} = \text{£}8.30 + \text{Number of units used} \times 8 \text{ pence}$$

Calculate the cost for a) 700 units b) 1150 units

- 3) The cost of hiring a wallpaper stripper is calculated using the following formula $C = 3n + 4$ where n represents the number of days it is hired for, and C the cost in pounds.

Calculate the cost of hiring it for a) 2 days b) 5 days.

If the cost is £16, how many days is it hired for?

- 4) A chicken needs to cook for 20 minutes plus 34 minutes for each kilogram it weighs.

Calculate the time needed to cook chicken weighing

a) 2kg b) 1.5kg

Exercise 2

Calculate the following values given that $a = 3$, $b = 4$ and $c = 5$

- | | | |
|-------------------|--------------------|-------------------|
| 1) $a + b$ | 2) $a + c$ | 3) $c + b$ |
| 4) $c - b$ | 5) $b - a$ | 6) $c - a$ |
| 7) $a - b$ | 8) $a - c$ | 9) $b - c$ |
| 10) $2a - b$ | 11) $2a + b$ | 12) $2c + 2b$ |
| 13) $2c - 2b$ | 14) $3a - 2c$ | 15) $4a - 4c$ |
| 16) $3a + 4b + 5$ | 17) $5a - b + 3$ | 18) $a - b + 7$ |
| 19) $a - b - c$ | 20) $3a + 2b - 4c$ | 21) $3a - 2b + 6$ |

Exercise 3

Calculate the values of these expressions given that $a = 1$, $b = -2$ and $c = 3$

- | | | |
|-------------------|--------------------|-------------------|
| 1) $a + b$ | 2) $b + c$ | 3) $a - c$ |
| 4) $2b + a$ | 5) $b + 3c$ | 6) $b - 2$ |
| 7) $3a + 2b$ | 8) $4a + b$ | 9) $-7 + 2b$ |
| 10) $b + a + c$ | 11) $c + a + b$ | 12) $3c + 2b$ |
| 13) $b - 6 + 2a$ | 14) $3a + 2b + c$ | 15) $5a + 5b - 7$ |
| 16) $b - a + c$ | 17) $c + b - a$ | 18) $3a - a - c$ |
| 19) $5a + 2b - 9$ | 20) $4b + 2a - 7c$ | 21) $2b - 3a + 9$ |

Exercise 4

Calculate the value of each of these expressions given that $x = 4$, $y = 5$ and $z = -2$

- | | | |
|--------------------|--------------------|--------------------|
| 1) $2(x + y)$ | 2) $3(y + x)$ | 3) $4(y + z)$ |
| 4) $3(y + x)$ | 5) $x(y + 2)$ | 6) $y(5 + z)$ |
| 7) $y(x + z)$ | 8) $2(x + y + z)$ | 9) $x(z + y)$ |
| 10) $x(y + z + 7)$ | 11) $y(z + x + 6)$ | 12) $5(z + y - x)$ |

33. Substitution 2

Calculate the following values given that $a = 3$, $b = 4$ and $c = 5$

1) $3a + 4b$

2) $5a - b$

3) $a - b - c$

4) $3a + 2b - 4c$

5) $5c - 7a$

6) $3a - 2b + 6$

Calculate the values of the expressions in questions 7 to 12 given that $a = 1$, $b = -2$ and $c = 3$

7) $4a + 2b - c$

8) $3a + 2b - 4c$

9) $6a - 7b$

10) $a + b - c$

11) $3a - 3b - c$

12) $4a - 2b - c$

13) If $v = u + at$, find v when $u = 2$, $a = 0.25$ and $t = 6$

14) Find the area of a circle of radius 2.54cm if $A = \pi r^2$ and $\pi = 3.142$

15) Find the circumference of a circle of diameter 6.5cm if $C = \pi D$

16) If $y = mx + c$ find the value of y when $m = 6$, $x = 2$ and $c = 1$

17) The volume of a cone is given by $V = \frac{1}{3} \pi r^2 h$. Find its volume when $\pi = 3.142$,
 $r = 3\text{cm}$, and $h = 2.5\text{cm}$.

18) The temperature F ($^{\circ}$ Fahrenheit) is connected to the temperature C ($^{\circ}$ Celsius) by the
formula $C = \frac{5}{9}(F - 32)$. Find, to the nearest degree, the value of C when $F = 82^{\circ}$

19) Find the simple interest paid if the principal (P) is £250, the time (T) is 3 years and the rate
of interest (R) is 9.5% using the formula $I = \frac{PTR}{100}$

20) If $v^2 = u^2 + 2as$ find v when $u = 7.3$, $a = 1.1$ and $s = 150$.

21) If $v^2 = 2gh$ find v when $g = 9.8$ and $h = 12$.

22) If $S = \frac{1}{2}(u + v)t$ find S when $u = 20$, $v = 57.5$ and $t = 2.5$.

23) If $A = \frac{2x + y}{3}$ find A when $x = 6$ and $y = 19$

24) If $P = \frac{Rx^2}{2y}$ find P when (a) $R = 6$, $x = 7$ and $y = 4$, (b) $R = -3$, $x = -2$, and $y = 5$

25) If $x = \frac{bc}{b - c}$ find x when $b = 13$ and $c = 9$.

26) If $y = 4x^2 + 3x - 2$ find y when x is (a) 3 (b) -2

27) If $y = 3x^2 - 2x + 1$ find y when x is (a) 5 (b) -1

28) If $y = (x + 3)(x - 4)$ find y when x is (a) 3 (b) -3

29) If $y = (3x - 2)(x + 1)$ find y when x is (a) 7 (b) -3

30) If $y = 2x^2 + \frac{1}{x}$ find y when $x = -2$

31) If $v = u + at$, calculate v when $u = 10$, $a = -9.8$ and $t = 6$.

32) If $v^2 = u^2 + 2as$, calculate the value of v when $u = 40$, $a = -9.8$ and $s = 40$

34. Forming Expressions

- 1) James buys a bicycle. He pays a deposit of £d and then 12 equal monthly amounts of £m.
 - a) How much does he pay for the bicycle?
 - b) If his mum gives him £10 towards it, how much will he pay?
- 2) Charles works for a local builder. He gets paid £h for each hour he works in the week
At weekends he is paid double the amount per hour.
 - a) How much is he paid if he works for 36 hours during the week?
 - b) How much is he paid for working 1 hour at the weekend?
 - c) how much is he paid for working 6 hours at the weekend?
 - d) How much is he paid for working 36 hours during the week plus 6 hours at the weekend?
Simplify your answer.
 - e) His friend Matthew is paid £1 per hour more than him during the week.
How much is Matthew paid for working 35 hours during the week?
- 3) Emily's car will travel T miles on 1 litre of petrol around town. When it gets on the motorway it will travel 2 miles more per litre.
 - a) How far will Emily's car travel on 1 litre of petrol on the motorway?
Amy's car will travel 1 mile further than Emily's car on 1 litre of petrol in the town.
 - b) How far will Amy's car travel on 1 litre of petrol in town?
 - c) On the motorway, Amy's car travels twice as far as Emily's on 1 litre of petrol.
How far does it travel on 1 litre of petrol on the motorway?
- 4) The Swift bus company have a formula for calculating their cost of hiring a bus.
The cost of hiring is £h plus £w for every hour it is hired.
 - a) What is the cost of hiring a bus for 8 hours?
The Swallow bus company charge £2 more than Swift for hiring it but its hourly rate is £1 less.
 - b) What hiring charge does the Swallow company charge?
 - c) What is the hourly rate for the Swallow company?
 - d) What does the Swallow company charge for hiring the bus for 8 hours?
- 5) A telephone company charge their customers at a rate of r pence a call.
 - a) What is the cost in pence of 200 calls?
 - b) What is the cost in pounds of 200 calls?
The telephone bill of a second company is made up of £c plus p pence for every call made.
 - c) What is the cost of a bill when no calls are made?
 - d) What is the cost of a bill when 100 calls are made?
 - e) What is the cost of a bill when 300 calls are made?
- 6) A glazing company replace broken windows. They charge their customers at a rate of £C for being called out and £A for each square metre of glass they have to replace.
 - a) What is the cost of replacing 8 square metres of glass?
 - b) During one week they are called out to the local nightclub twice, once to replace 8 square metres and once to replace 6 square metres. What is the total bill for the week.
- 7) Jessica, Ella and Rachel save up some of their pocket money each week. Jessica saves £M, Ella saves twice as much and Rachel saves £2 more than Jessica. Which of these is correct?
 - a) Ella saves the most.
 - b) Rachel saves the most.
 - c) Jessica saves the least.
 They decide to combine their money to go to town.
 - d) How much do they have altogether?
- 8) Matthew has to plant young trees in straight rows. Each tree needs t metres of row and each row needs an extra e metres.
 - a) How long is a row of 12 trees?
 - b) What is the total length of 2 rows?

35. Simplifying Expressions 1

Exercise 1

1) (i) The perimeter of this

square is
 $2x + 2x + 2x + 2x$

Simplify it.

(ii) The area of this
 square is $2x \times 2x$
 Simplify it.

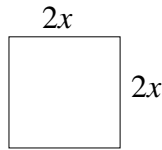

2) (i) The perimeter of this
 rectangle is $5 + y + 5 + y$
 Simplify it.

(ii) The area of this shape
 is $5 \times y$
 Simplify it

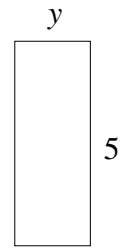

3) Write down the perimeter of each of the shapes below in the simplest form.

(i)

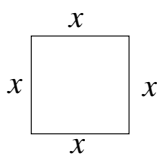

(ii)

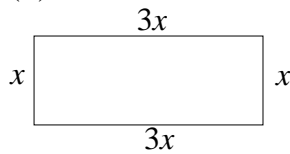

(iii)

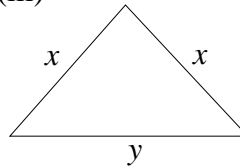

(iv)

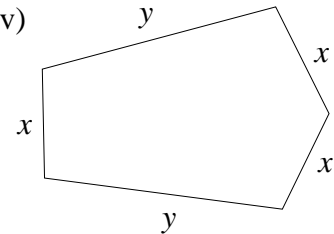

4) Write down the areas of the shapes (i) and (ii) in question 3 in their simplest form.

Exercise 2 Simplify

- 1) $7 + 4$
- 3) $12 - 3$
- 5) $6 - 9$
- 7) $-4 + 8$
- 9) $-4 + 10$
- 11) $-7 - 4$
- 13) $4 - 3 + 2$
- 15) $5 - 9 + 5$
- 17) $-4 + 6 - 3$
- 19) $8 - 15 + 3$

- 2) $10 - 5$
- 4) $8 - 9$
- 6) $7 - 10$
- 8) $-6 + 9$
- 10) $-5 - 3$
- 12) $-9 - 6$
- 14) $6 - 7 + 1$
- 16) $6 - 10 - 2$
- 18) $-7 + 2 + 4$
- 20) $-5 - 4 + 9$

Exercise 3 Simplify

- 1) $3y + 8y$
- 3) $9y - 6y$
- 5) $16y - 18y$
- 7) $-12y + 3y$
- 9) $-16a - 7a$
- 11) $12b + 3b + 2a + 3a$
- 13) $4b + 5a + 3b + 3a$
- 15) $6a - 2a + 3b + 4b$
- 17) $12a + 3b - 4a - b$
- 19) $16x + 8y - 10x - 9y$
- 21) $6x + 3y - 8x - 6y$

- 2) $5y + 3y$
- 4) $12x - 4x$
- 6) $27x - 19x$
- 8) $-23x + 17x$
- 10) $-14w - 5w$
- 12) $9x + 7y + 3x + 6y$
- 14) $x + 6y + y + x$
- 16) $12p - 4p + 3q + 7q$
- 18) $5x + 7y - y - x$
- 20) $21a + 3b - 17a - 2b$
- 22) $12a + 9b - 6a - 12b$

Exercise 4 Multiply out the brackets and simplify

- 1) $3(x + y)$
- 3) $4(2x - 3)$
- 5) $3x + 2(2x + 5)$
- 7) $5x + 4(3x - 3)$
- 9) $4y + 3(3x - 2y)$
- 11) $3y + 2(4x + y)$
- 2) $6(3x + 4)$
- 4) $6(3x + 2)$
- 6) $7(3x - 4)$
- 8) $12x + 5(2x + 3)$
- 10) $8x + 3(2x - 4y)$
- 12) $9y + 4(6x - 2y)$

36. Simplifying Expressions 2

Exercise 1 Simplify

- | | | | |
|------------------|--------------------|-------------------------|------------------|
| 1) $3 + 5$ | 2) $4 + 7$ | 3) $8 + 9$ | 4) $10 + 47$ |
| 5) $27 + 95$ | 6) $6 - 4$ | 7) $54 - 7$ | 8) $45 - 24$ |
| 9) $4 - 6$ | 10) $2 - 7$ | 11) $4 - 16$ | 12) $5 - 11$ |
| 13) $-3 + 8$ | 14) $-4 + 18$ | 15) $-17 + 22$ | 16) $-6 + 27$ |
| 17) $-13 + 12$ | 18) $-15 + 20$ | 19) $-9 + 34$ | 20) $-16 + 34$ |
| 21) $-5 - 13$ | 22) $-4 - 35$ | 23) $-12 - 45$ | 24) $-45 - 55$ |
| 25) $-45 - 26$ | 26) $-32 - 43$ | 27) $-4 + 8 - 7$ | 28) $-9 + 8 - 6$ |
| 29) $9 - 14 + 6$ | 30) $12 - 43 + 17$ | 31) $-54 + 34 + 12 - 6$ | |

Exercise 2 Simplify

- | | | | |
|-----------------|-----------------|-----------------|-----------------|
| 1) $4x + 2x$ | 2) $5y + 3y$ | 3) $7z + 4z$ | 4) $5a + 7a$ |
| 5) $9b - 4b$ | 6) $8x - 2x$ | 7) $9a - a$ | 8) $4z - 9z$ |
| 9) $-6z + 9z$ | 10) $-12a + 8a$ | 11) $-18x + 3x$ | 12) $-12a + 8a$ |
| 13) $-22b - 8b$ | 14) $-15x - 5x$ | 15) $-23b - 6b$ | 16) $-14z - 5z$ |

Exercise 3 Simplify

- | | | |
|---------------------------|----------------------------|----------------------------|
| 1) $14x + 12x - 9x$ | 2) $6y - 13y - 5y$ | 3) $17z - 7z + 6z$ |
| 4) $-4a - 9a + a$ | 5) $-11b + 5b - 7b$ | 6) $-23x + 12x + 9x$ |
| 7) $-14a - a - 12a$ | 8) $23z - 4z + 6z$ | 9) $9z - 8z - z - 5z$ |
| 10) $-13a - 9a + 4a + 6a$ | 11) $12x + 13x - 12x - x$ | 12) $14a - 5a - 9a + 4a$ |
| 13) $15b - 5b - 7b - 6b$ | 14) $-23x + 9x - 13x + 8x$ | 15) $-15b + 7b + 19b - 3b$ |

Exercise 4 Simplify

- | | | |
|------------------------------|--------------------------------|-----------------------------|
| 1) $-12xy + 12xy - 8xy$ | 2) $-7xy + 15xy - 15xy$ | 3) $12yz - 6yz - 9yz$ |
| 4) $5ab - 7ab + 3ab$ | 5) $9ab - 4ab - 6ab$ | 6) $12xy - 13xy + xy$ |
| 7) $-15ab + ab + 9ab$ | 8) $-32yz - 8yz + 5yz$ | 9) $15yz + 6yz - 4yz - 8yz$ |
| 10) $12ab - 11ab - ab + 5ab$ | 11) $14xy - 12xy - 2xy - 6xy$ | |
| 12) $-6ab - 9ab - 5ab + 7ab$ | 13) $-14ab - 8ab + 12ab - 4ab$ | |
| 14) $2xy + 6xy - 8xy + 5xy$ | 15) $6ab - 8ab + 5ab - 4ab$ | |

Exercise 5 Simplify

- | | | | |
|------------------|--------------------|-------------------|---------------------|
| 1) $3x^2 + 5x^2$ | 2) $4x^2 + 6x^2$ | 3) $7x^2 + 2x^2$ | 4) $5x^2 + 5x^2$ |
| 5) $3x^2 - 5x^2$ | 6) $6x^2 - 4x^2$ | 7) $5x^2 - 8x^2$ | 8) $7x^2 - 8x^2$ |
| 9) $-5x^2 + x^2$ | 10) $-3x^2 + 5x^2$ | 11) $-x^2 - 5x^2$ | 12) $-8x^2 - 62x^2$ |

37. Multiplying Brackets

Exercise 1

Calculate

- | | | |
|---------------------|----------------------|-----------------------|
| 1) 4×5 | 2) 3×7 | 3) $6 \times (-5)$ |
| 4) $4 \times (-5)$ | 5) -3×7 | 6) -7×9 |
| 7) $-9 \times (-6)$ | 8) $-5 \times (-11)$ | 9) $-6 \times (-8)$ |
| 10) -7×9 | 11) $12 \times (-7)$ | 12) $-5 \times (-11)$ |

Exercise 2

Expand and simplify

- | | | |
|-------------------|-------------------|-------------------|
| 1) $4(x + 2)$ | 2) $5(x + 7)$ | 3) $6(x + 8)$ |
| 4) $3(3x + 4)$ | 5) $5(6x + 1)$ | 6) $3(5x + 2)$ |
| 7) $-2(x + 3)$ | 8) $-4(x + 2)$ | 9) $-6(x + 7)$ |
| 10) $5(x - 7)$ | 11) $3(x - 4)$ | 12) $7(x - 5)$ |
| 13) $-5(x - 2)$ | 14) $-3(x - 3)$ | 15) $-4(x - 1)$ |
| 16) $-6(2x - 5)$ | 17) $-4(x - 2)$ | 18) $-2(x - 3)$ |
| 19) $-4(-3x + 3)$ | 20) $-7(-5x - 6)$ | 21) $-6(-4x + 4)$ |

Exercise 3

Expand and Simplify

- | | |
|--------------------------|--------------------------|
| 1) $5x + 2 + 3(x + 1)$ | 2) $7x + 3 - 2(x + 7)$ |
| 3) $3x + 4 + 5(x - 2)$ | 4) $3x + 7 + 3(x - 5)$ |
| 5) $7(x - 2) + 5x - 6$ | 6) $5(x - 3) - 5x + 4$ |
| 7) $5(x - 2) - 7x + 3$ | 8) $9x + 3 - 8(x - 2)$ |
| 9) $-4(2x + 2) - 5x + 2$ | 10) $3x + 7 - 7(4x - 3)$ |

Exercise 4

Expand and simplify

- | | |
|-----------------------------|----------------------------|
| 1) $3(x + 3) + 4(x + 2)$ | 2) $6(x + 4) - 2(x + 3)$ |
| 3) $5(x + 3) + 2(x - 4)$ | 4) $5(x + 3) + 4(x - 2)$ |
| 5) $5(x - 4) + 3(x - 5)$ | 6) $7(x - 4) - 4(x + 9)$ |
| 7) $2(2x - 4) - 6(x + 3)$ | 8) $5(3x + 6) - 4(x - 4)$ |
| 9) $-5(3x + 5) - 2(2x + 3)$ | 10) $6(x + 2) - 3(3x - 5)$ |

Exercise 5

Expand and simplify

- | | | |
|-----------------------|-----------------------|------------------------|
| 1) $(x + 3)(x + 2)$ | 2) $(x + 4)(x + 3)$ | 3) $(x + 3)(x - 4)$ |
| 4) $(x + 5)(x - 3)$ | 5) $(x - 4)(x + 2)$ | 6) $(x - 2)(x - 5)$ |
| 7) $(x + 3)(x - 2)$ | 8) $(x - 4)(x - 5)$ | 9) $(x - 4)(x + 9)$ |
| 10) $(2x - 4)(x + 3)$ | 11) $(3x + 6)(x - 4)$ | 12) $(3x + 5)(2x + 3)$ |
| 13) $(x + 2)^2$ | 14) $(x - 4)^2$ | 15) $(x + 5)^2$ |
| 16) $(3x + 1)^2$ | 17) $(2x - 2)^2$ | 18) $(4x + 3)^2$ |
| 19) $(-x + 2)^2$ | 20) $(-2x + 4)^2$ | 21) $(-3x + 5)^2$ |

38. Factorising

Exercise 1

Factorise

- | | | |
|--------------------|---------------------|--------------------|
| 1) $3x + 6$ | 2) $5x - 15$ | 3) $6x - 15$ |
| 4) $4z + 12$ | 5) $8y + 20$ | 6) $18y - 6$ |
| 7) $16x - 20$ | 8) $16x - 24$ | 9) $14a - 16$ |
| 10) $24x + 36y$ | 11) $24x + 16y$ | 12) $21a + 14b$ |
| 13) $8x - 18z$ | 14) $18y + 27z$ | 15) $24p - 40q$ |
| 16) $3a + 3$ | 17) $16x + 16$ | 18) $5 - 5x^2$ |
| 19) $6a - 4b + 8c$ | 20) $5a + 10b - 5c$ | 21) $12 - 9a + 3b$ |

Exercise 2

Factorise

- | | | |
|-------------------|-------------------|-------------------|
| 1) $2a - a^2$ | 2) $6y - y^2$ | 3) $9x - x^2$ |
| 4) $x^2 - 3x$ | 5) $3a + 6a^2$ | 6) $4b - b^2$ |
| 7) $2y + 4y^2$ | 8) $5x^2 - 10x$ | 9) $4z^2 - 12z$ |
| 10) $6x - 9x^2$ | 11) $16y^2 + 20y$ | 12) $32z - 16z^2$ |
| 13) $20a - 35a^2$ | 14) $18x^2 - 15x$ | 15) $27a^2 - 18a$ |

Exercise 3

Factorise

- | | | |
|-----------------------|--------------------|-------------------------|
| 1) $ab + 2a$ | 2) $4x - xy$ | 3) $6a - 2ab$ |
| 4) $3a + 6a^2$ | 5) $9x^2 - 6x$ | 6) $2xy + 6x - x^2$ |
| 7) $12ab - a + a^2$ | 8) $7a^2 - 14ab$ | 9) $4\pi r^2 - 6\pi rh$ |
| 10) $20xy + 5y^2$ | 11) $16xy - 8xyz$ | 12) $8pq - 4p^2q$ |
| 13) $26p^2q - 13pq^2$ | 14) $9ab^2 - a^2b$ | 15) $16x^2y - 12xy^2$ |

Exercise 4 (mixed)

Factorise

- | | | |
|-----------------------|----------------------|------------------------|
| 1) $2a + 4b$ | 2) $3ah - a^2$ | 3) $5a + 15b + 10c$ |
| 4) $3y^2 + 21y$ | 5) $4abc - 12bc^2$ | 6) $6xy - 14x^2y^2$ |
| 7) $14x^2 - 32y$ | 8) $7x^2y + 14x$ | 9) $3\pi d - 7\pi d^2$ |
| 10) $16a + 30x$ | 11) $9ab - 27b^2$ | 12) $16a + 48a^2$ |
| 13) $8a + 6a^2 - 2ab$ | 14) $8x^2 + 2y - 6z$ | 15) $x + x^2 + xy$ |

39. Rearranging Formulae

Rearrange each of the following formulae to make its subject the letter indicated in the brackets.

$$1) C = \pi D \quad (D) \qquad 2) C = 2\pi r \quad (r)$$

$$3) F = ma \quad (m) \qquad 4) V = lbh \quad (h)$$

$$5) A = \frac{1}{2}bh \quad (h) \qquad 6) \quad = \frac{1}{3}\pi r^2 h \quad (h)$$

$$7) y = mx + c \quad (c) \qquad 8) y = mx + c \quad (m)$$

$$9) v = \pi r^2 h \quad (h) \qquad 10) v = \pi r^2 h \quad (r)$$

$$11) C = \frac{5}{9}(F - 32) \quad (F) \qquad 12) y = \frac{2}{3}(a + b) \quad (b)$$

$$13) v^2 = 2gh \quad (h) \qquad 14) v^2 = u^2 + 2as \quad (s)$$

$$15) \quad = ut + \frac{1}{2}at^2 \quad (a) \qquad 16) s = \frac{1}{2}(u + v)t \quad (v)$$

$$17) N = 2\pi\sqrt{l} \quad (l) \qquad 18) X = 4lr^2 \quad (r)$$

$$19) A = \frac{2x + y}{3} \quad (x) \qquad 20) p = \frac{(x - y)^2}{6} \quad (x)$$

$$21) p = \frac{Rx^2}{2y} \quad (x) \qquad 22) C = \frac{Dx^2}{zy} \quad (y)$$

$$23) I = \frac{x}{y}\sqrt{w} \quad (w) \qquad 24) I = \frac{PTR}{100} \quad (R)$$

$$25) C = d + t\sqrt{x} \quad (x) \qquad 26) A = \pi(R^2 - r^2) \quad (R)$$

$$27) A = \pi(R^2 - r^2) \quad (r) \qquad 28) x = 2a + b^2 \quad (b)$$

$$29) a = \sqrt{\frac{C(x - c)}{b}} \quad (b) \qquad 30) x = \sqrt{\frac{a}{a + b}} \quad (b)$$

40. Making and Solving Equations

1) This is an example of three consecutive numbers being added together

$$6 + 7 + 8 = 21$$

Three other consecutive numbers are added together.

The first number is x

- a) In terms of x what is the second number?
- b) In terms of x what is the third number?
- c) In terms of x , what is the sum of all three numbers? Simplify your answer.
- d) The three numbers add up to 45. Write down an equation in terms of x to show this.
- e) Calculate the values of the three numbers.

2) Three other consecutive numbers are added together.

The middle number is y

- a) In terms of y what is the first number?
- b) In terms of y what is the third number?
- c) In terms of y , what is the sum of all three numbers? Simplify your answer.
- d) Complete this statement
 'To calculate the sum of three consecutive numbers, multiply the middle number by....'
- e) Hence calculate the sum of the numbers 149, 150, 151.
- f) If three consecutive numbers add up to 75, what are they?

3) The top of a *square* garden table is made by sticking a number of tiles measuring x cm by y cm onto a wooden board.

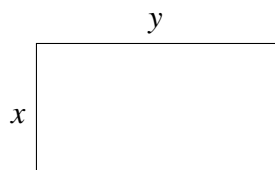

a) If the length of the tile, y , is 4cm longer than it's width, x , complete this equation

$$y = x$$

35 of these tiles are put together to make the table top.

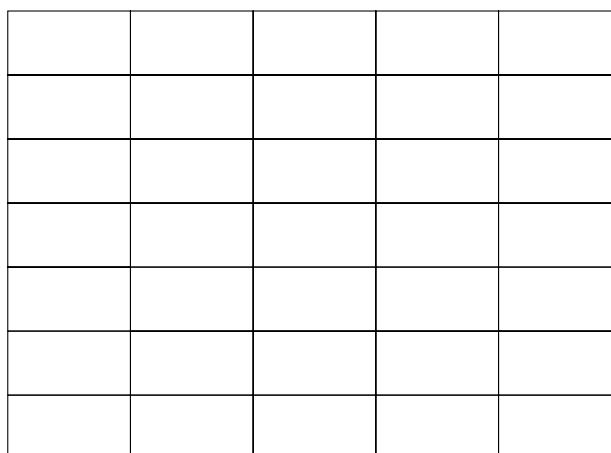

- b) In terms of x , write down two expressions for the sides of the square.
- c) Write down an equation satisfied by x .
- d) Solve the equation and write down the length of the sides of the square.
- e) What is the area of the table top?

41. Equations

Exercise 1

- 1) Jane thought of a number. She doubled it. If the answer was 20, what number was she thinking of?
- 2) Sam thought of a number. He added 14 to it. If his answer was 20 what number was he thinking of?
- 3) Tiffany thought of a number. She doubled it then added 6. If her answer was 22, what number did she think of?
- 4) Ben thought of a number. He halved it, then subtracted 5. If his answer was 5, what number did he think of?
- 5) When a number is multiplied by 9 and then 3 subtracted, the answer is 24. What is the number?
- 6) A number has 6 added to it. The result is doubled. If the answer is 18, what was the number?
- 7) A number is multiplied by 2 and then 8 is subtracted. If the answer is -4 , what was the number?

Exercise 2

Find the value of the letter in each of the following equations

- | | | |
|------------------|-------------------|-----------------|
| 1) $x + 2 = 5$ | 2) $x + 3 = 7$ | 3) $x + 4 = 15$ |
| 4) $x - 3 = 4$ | 5) $x - 2 = 15$ | 6) $x - 7 = 12$ |
| 7) $x - 5 = -2$ | 8) $x + 4 = -15$ | 9) $x - 7 = -6$ |
| 10) $7 + x = 11$ | 11) $12 + x = 17$ | 12) $3 + x = 9$ |
| 13) $5 - x = 2$ | 14) $10 - x = 1$ | 15) $8 - x = 3$ |

Exercise 3

- | | | |
|--------------------|--------------------|--------------------|
| 1) $2x = 12$ | 2) $4x = 16$ | 3) $5x = 50$ |
| 4) $3x = -15$ | 5) $5x = -25$ | 6) $7x = -49$ |
| 7) $2x + 1 = 17$ | 8) $5x + 3 = 38$ | 9) $6x + 7 = 43$ |
| 10) $4x - 5 = 23$ | 11) $3x - 5 = 31$ | 12) $4x - 9 = 51$ |
| 13) $2x - 7 = -11$ | 14) $5x - 9 = -34$ | 15) $6x + 34 = 10$ |

Exercise 4

- | | | |
|-----------------------|-----------------------|------------------------|
| 1) $x + 4 = 2x$ | 2) $x + 9 = 4x$ | 3) $x + 12 = 3x$ |
| 4) $x - 5 = 2x$ | 5) $x - 9 = 4x$ | 6) $x - 36 = 5x$ |
| 7) $2x + 5 = 3x$ | 8) $3x + 8 = 5x$ | 9) $7x + 12 = 9x$ |
| 10) $4x - 6 = 2x$ | 11) $3x - 3 = 2x$ | 12) $7x - 10 = 2x$ |
| 13) $x + 4 = 2x + 2$ | 14) $3x + 1 = 2x + 4$ | 15) $4x + 14 = 5x + 4$ |
| 16) $6x - 5 = 3x + 4$ | 17) $6x + 8 = 8x - 4$ | 18) $5x - 4 = 9x + 12$ |

Exercise 5

- | | | |
|----------------------|-----------------------|----------------------|
| 1) $2(x + 1) = 6$ | 2) $3(x + 3) = 21$ | 3) $4(x + 4) = 32$ |
| 4) $5(x + 5) = 35$ | 5) $7(x + 3) = 35$ | 6) $10(x + 4) = 30$ |
| 7) $4(x + 10) = 32$ | 8) $6(x + 6) = 24$ | 9) $5(x + 4) = 60$ |
| 10) $4(x - 1) = 2$ | 11) $5(x - 3) = 20$ | 12) $7(x - 4) = 49$ |
| 13) $6(x - 4) = 36$ | 14) $4(x - 4) = 48$ | 15) $6(x - 7) = 42$ |
| 16) $2(2x - 1) = 14$ | 17) $3(3x - 4) = 42$ | 18) $5(5x - 4) = 55$ |
| 19) $2(4x - 6) = 36$ | 20) $5(7x - 8) = 100$ | 21) $5(3x + 8) = 70$ |

42. More Equations

Find the value of the letter in each of the following

Exercise 1

- | | | |
|---|---|--------------------------------------|
| 1) $\frac{1}{2}x = 6$ | 2) $\frac{1}{3}x = 4$ | 3) $\frac{1}{6}x = 8$ |
| 4) $\frac{3x}{4} = 6$ | 5) $\frac{7x}{10} = 14$ | 6) $\frac{2x}{3} = 12$ |
| 7) $\frac{7}{9}x = 14$ | 8) $\frac{7}{4}x = 21$ | 9) $\frac{13}{4}x = 39$ |
| 10) $\frac{1}{2}x + 2 = 5$ | 11) $\frac{1}{4}x + 7 = 15$ | 12) $\frac{1}{6}x - 3 = 12$ |
| 13) $\frac{2}{3}x + 5 = 13$ | 14) $\frac{3}{4}x - 3 = 6$ | 15) $\frac{2}{5}x + 3 = 9$ |
| 16) $\frac{7}{9}x - 6 = 1$ | 17) $\frac{5}{6}x + 2 = 17$ | 18) $\frac{6}{7}x + 2 = 14$ |
| 19) $\frac{x+3}{3} = 3$ | 20) $\frac{2x+4}{7} = 2$ | 21) $\frac{3x-2}{4} = 4$ |
| 22) $\frac{3x+3}{6} = 4$ | 23) $\frac{5x+4}{7} = 2$ | 24) $\frac{3x-7}{2} = 16$ |
| 25) $\frac{x}{3} + \frac{x}{4} = 14$ | 26) $\frac{2x}{5} + \frac{x}{4} = 13$ | 27) $\frac{x}{3} - \frac{x}{7} = 12$ |
| 28) $\frac{x-1}{3} + \frac{x+2}{2} = 34$ | 29) $\frac{2x-1}{3} - \frac{x+1}{4} = 4$ | 30) $\frac{3(x+2)}{5} = 6$ |
| 31) $\frac{1}{2}(x+2) + \frac{1}{3}(x-1) = 4$ | 32) $\frac{1}{4}(10-x) + \frac{1}{3}(x+7) = 5$ | |
| 33) $\frac{1}{4}(x+5) + \frac{1}{2}(1+x) = 7$ | 34) $\frac{3}{4}(8+x) - \frac{1}{3}(x-1) = 8$ | |
| 35) $\frac{1}{2}(x-2) + \frac{1}{4}(x-1) = 1$ | 36) $\frac{3}{4}(x+11) - \frac{2}{3}(17-x) = 4$ | |

Exercise 2

- | | | |
|-------------------------|--------------------------|--------------------------|
| 1) $(x-2)(x-3) = 0$ | 2) $(x+1)(x-5) = 0$ | 3) $(x+2)(x+5) = 0$ |
| 4) $(x+2)(x-3) = 0$ | 5) $(x+6)(x-2) = 0$ | 6) $(5x+20)(x+1) = 0$ |
| 7) $x^2 + 5x + 6 = 0$ | 8) $x^2 - 5x + 6 = 0$ | 9) $x^2 + 5x + 4 = 0$ |
| 10) $x^2 - 5x + 4 = 0$ | 11) $x^2 + 11x + 18 = 0$ | 12) $x^2 - 11x + 18 = 0$ |
| 13) $x^2 - 7x + 10 = 0$ | 14) $x^2 + 9x + 20 = 0$ | 15) $x^2 + 7x + 12 = 0$ |
| 16) $x^2 - 3x - 10 = 0$ | 17) $x^2 + 5x - 6 = 0$ | 18) $x^2 - 9x - 10 = 0$ |
| 19) $x^2 + 5x - 14 = 0$ | 20) $x^2 - 8x - 20 = 0$ | 21) $x^2 - 4x - 21 = 0$ |
| 22) $x^2 - 6x + 9 = 0$ | 23) $x^2 - 10x + 25 = 0$ | 24) $x^2 - 4x - 32 = 0$ |

43. Simultaneous Equations

Solve these simultaneous equations.

$$\begin{aligned} 1) \quad & 3x + 2y = 8 \\ & x + 2y = 4 \end{aligned}$$

$$\begin{aligned} 2) \quad & 3x + 4y = 17 \\ & x + 4y = 11 \end{aligned}$$

$$\begin{aligned} 3) \quad & 5x + y = 15 \\ & 3x + y = 11 \end{aligned}$$

$$\begin{aligned} 4) \quad & 2x + 3y = 13 \\ & 3x + 3y = 18 \end{aligned}$$

$$\begin{aligned} 5) \quad & 2x + 4y = 14 \\ & 5x + 4y = 23 \end{aligned}$$

$$\begin{aligned} 6) \quad & 6x + 2y = 14 \\ & 3x + 2y = 11 \end{aligned}$$

$$\begin{aligned} 7) \quad & x + y = 4 \\ & x - y = 2 \end{aligned}$$

$$\begin{aligned} 8) \quad & 2x + 4y = 16 \\ & 2x - 4y = 0 \end{aligned}$$

$$\begin{aligned} 9) \quad & 4x + 3y = 26 \\ & 3x - 3y = 9 \end{aligned}$$

$$\begin{aligned} 10) \quad & 4x + 2y = 28 \\ & x + y = 9 \end{aligned}$$

$$\begin{aligned} 11) \quad & 5x - 3y = 9 \\ & 2x - y = 4 \end{aligned}$$

$$\begin{aligned} 12) \quad & 4x + 3y = 23 \\ & 2x + 6y = 34 \end{aligned}$$

$$\begin{aligned} 13) \quad & 3x + 2y = 13 \\ & 2x + 3y = 12 \end{aligned}$$

$$\begin{aligned} 14) \quad & 2x + 4y = 12 \\ & 3x - 2y = 10 \end{aligned}$$

$$\begin{aligned} 15) \quad & 5x + y = 16 \\ & 3x - y = 8 \end{aligned}$$

$$\begin{aligned} 16) \quad & 4x + 2y = 14 \\ & 2x + 4y = 16 \end{aligned}$$

$$\begin{aligned} 17) \quad & 5x + 4y = 27 \\ & 2x - 3y = -3 \end{aligned}$$

$$\begin{aligned} 18) \quad & 6x + 3y = 27 \\ & 4x - 2y = 14 \end{aligned}$$

19) The sum of two numbers is 14 and their difference is 4.

- Letting x and y be the two numbers write down two equations.
- Solve the equations.

20) The sum of two numbers is 24 and their difference is 6.

- Letting x and y be the two numbers write down two equations.
- Solve the equations.

21) The cost of 4 drinks and 3 sandwiches is £4.10.

The cost of 3 drinks and 1 sandwich is £2.20.

Let x represent the price of a drink and let y represent the price of a sandwich.

- Write down two equations linking the prices of the drinks and sandwiches.
- Solve the equations.
- Write down the price of one sandwich and the price of one drink.

22) Two large boxes and three small boxes contain 56 cans of soup.

Three large boxes and one small box also hold 56 cans of soup.

Let x represent the number of cans in a large box and y the number of cans in a small box.

- Write down two equations relating x and y .
- Solve the equation for x and y .
- How many cans of soup are in each box?

23) Jessica has some weights. Some are large and some are small. When she puts 3 large and 4 small weights on the scales they measure 15kg. When she puts 4 large and 3 small weights on the scale they measure 16.5kg.

- Letting x represent the value of the large weight and y the value of the small one write down two equations linking x and y .
- Calculate the values of x and y .
- What are the sizes of the two weights?

44. Using Simple Equations

- 1) Three consecutive numbers are added together and their sum is 81.
- If the first number is x , write down expressions for the 2nd and 3rd numbers.
 - Use these expressions to calculate the value of x and hence the three numbers.
- 2) Three numbers are added together. The first number is twice the value of second number. The third number is 3 less than the first number. If the first number is x ;
- Write down the second and third numbers in terms of x .
 - If all the numbers add up to 57, write down a simplified equation for their total in terms of x .
 - What are the three numbers?

- 3) The length of a rectangle is 30cm. Its width is $(x - 3)$ cm.

- Write down its area in terms of x .
- If its area is 750cm^2 , calculate the value of x .
- What is the width of the rectangle?

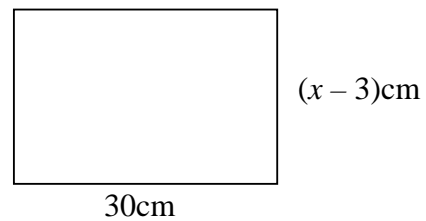

- 4) The length of a rectangle is 23cm. Its width is $(x - 4)$ cm. Its perimeter is 68cm.

- Calculate the value of x .
- What is the width of the rectangle?
- What is the area of the rectangle?

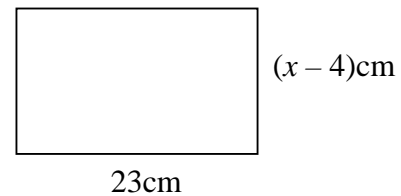

- 5) Calculate the sizes of the angles in each of these diagrams

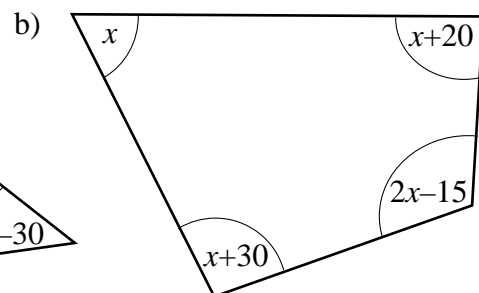
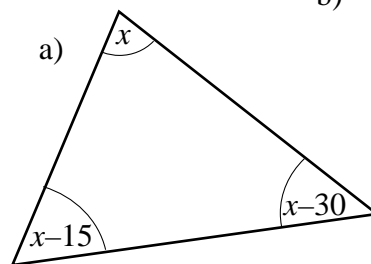

- 6) James has 15 stamps. Some are valued at 30p and the rest at 40p.
- If there are x number of 30p stamps, write down the number of 40p stamps, in terms of x .
 - The total value of the stamps is £5.00. Write down an equation linking the total value to x .
 - Calculate the value of x .
 - How many stamps are there of each value?

45. Using Quadratic Equations

- 1) A rectangle has a length of $(x + 4)$ centimetres and a width of $(x - 3)$ centimetres.

a) If the perimeter is 34cm, what is the value of x ?

b) If the area is 18cm^2 , show that

$x^2 - x - 30 = 0$ and calculate the value of x when the area is 18cm^2

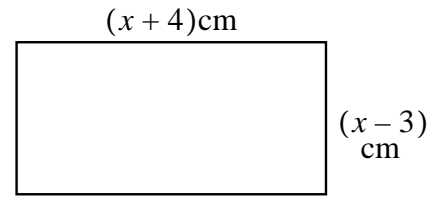

- 2) x people go to the cinema. The cost of one ticket is $\pounds(x-4)$. If the total cost of the tickets is $\pounds 12$, calculate the number of people who went to the cinema.

- 3) The mean of x numbers is $x-3$. If the total of all the numbers is 70:

a) show that $x^2 - 3x - 70 = 0$.

b) Hence calculate x .

c) What is the mean of the numbers?

- 4) The square and the rectangle have the same areas.

a) Show that $x^2 - 5x = 0$

b) calculate x and hence the area of the square.

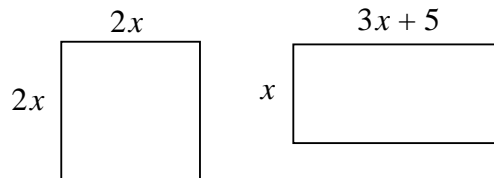

- 5) Shirts cost $\pounds(x-6)$ each. If $(x+5)$ shirts are bought for a total of $\pounds 180$.

a) Show that $x^2 - x - 210 = 0$

b) Solve this equation

c) (i) What is the cost of one shirt?

(ii) How many shirts were bought?

- 6) A right angled triangle has the dimensions, measured in centimetres, shown in the diagram.

a) By using Pythagoras' theorem, show that

$$x^2 - 10x - 11 = 0$$

b) Solve this equation and write down the length of the sides of the triangle.

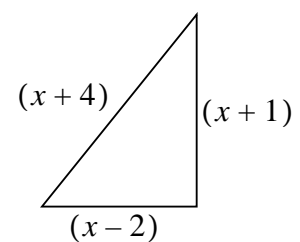

- 7) A company manufacture x thousand boxes of chocolates each week. The number of chocolates in each box is $(x+5)$ chocolates. During one particular week, the chocolate making machine breaks down and they only make $(x-9)$ thousand boxes. At the end of the week they find that they have produced 120 thousand chocolates.

a) Show that $x^2 - 4x - 165 = 0$.

b) Solve this equation and calculate the number of boxes produced.

46. Co-ordinates

1) Write down the co-ordinates of the corners of this square

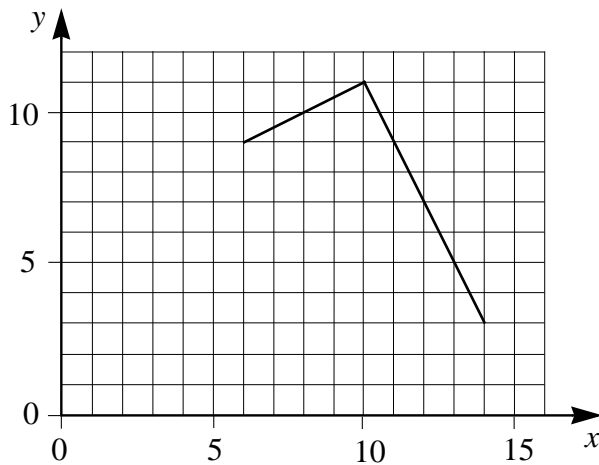
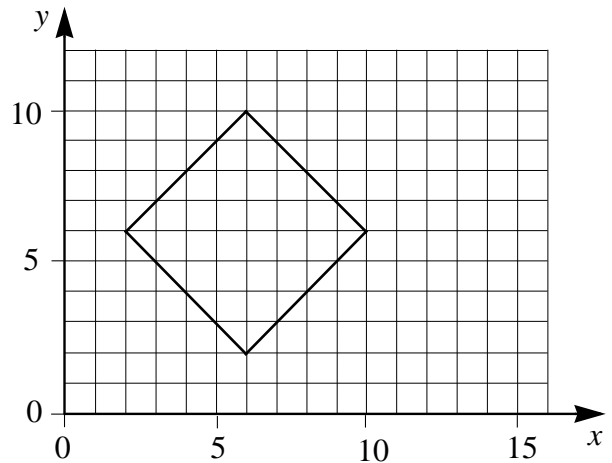

2) The diagram shows two sides of a rectangle.
 a) Write down the co-ordinates of the corners shown.
 b) What are the co-ordinates of the fourth corner?

3) The diagram shows a rectangle. Write down the co-ordinates of its corners.

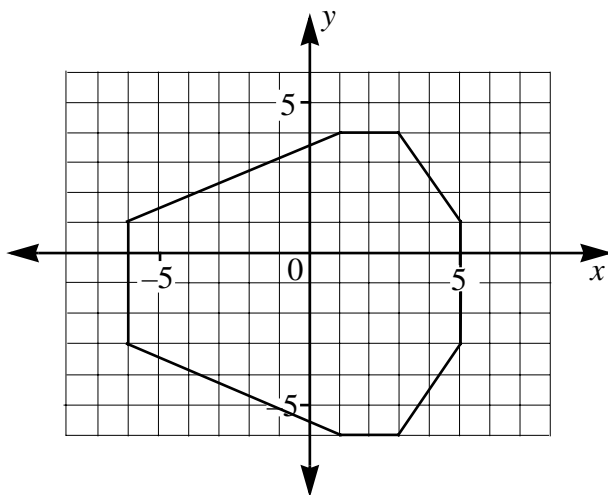
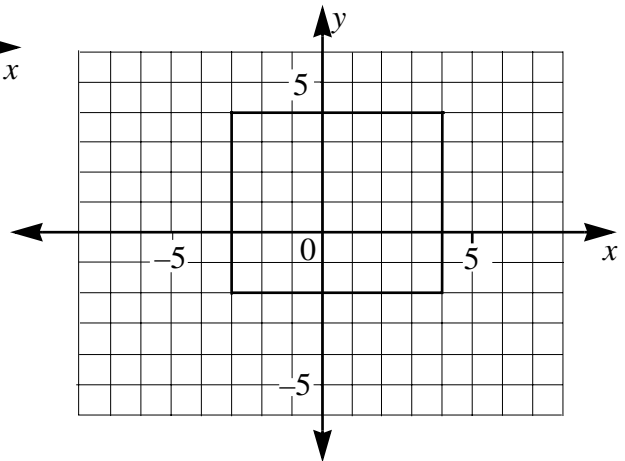

4) The diagram shows an octagon. Write down the co-ordinates of its corners.

5) The diagram shows two sides of a rectangle.
 a) Copy and complete the diagram.
 b) What are the co-ordinates of its four corners.

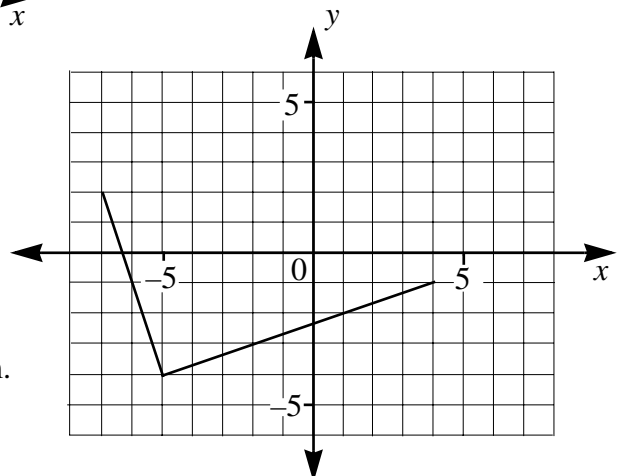

47. Sketching and Recognising Graphs 1

1) Sammi walks to school, keeping at the same speed all the way. Which of these graphs represents her journey.

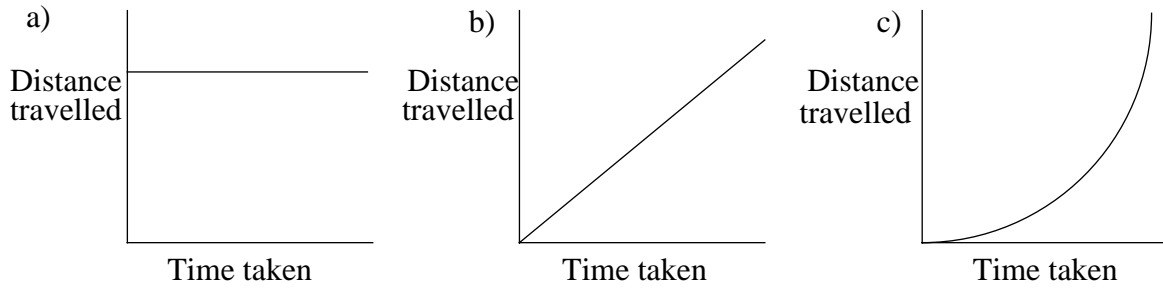

2) The Swimming Pool Corporation makes round swimming pools. The table below shows their prices.

Diameter	8 metres	10 metres	12 metres	14 metres	16 metres
Cost	£1920	£3,000	£4,320	£5,880	£7,680

Which of these graphs represents the prices of the pools.

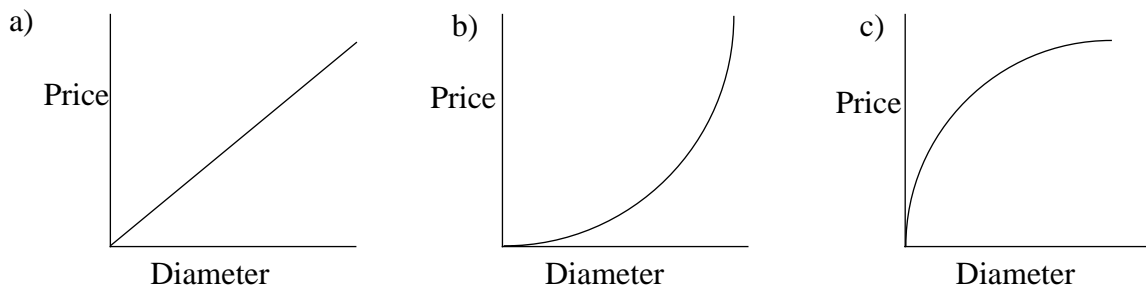

3) A train travels from Dorchester to Newchester. Its speed increases from 0 to 60mph. It then travels at a constant 60mph and finally it slows down from 60mph to 0mph. Which of these diagrams shows that journey.

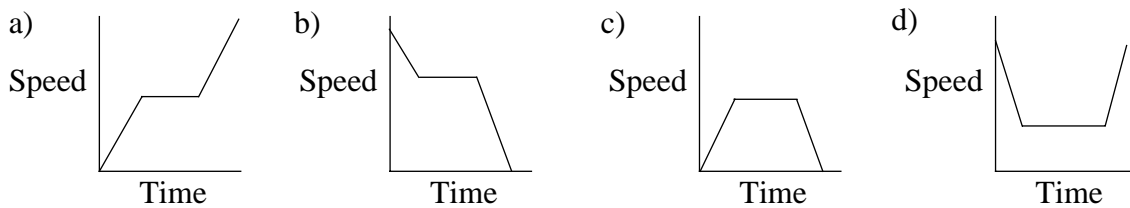

4) A shop sells stamps which cost 25p each. In order to help calculate their cost, the assistant uses the following list of prices to help him.

Number of stamps	1	5	10	20	50	100
Cost	25p	£1.25	£2.50	£5	£12.50	£25

Sketch the graph which represents their price plotted against the number sold.

48. Sketching and Recognising Graphs 2

1) A water tank with straight sides is full. A tap at the bottom is turned on and the water drained out at a constant rate. Which of these diagrams shows this.

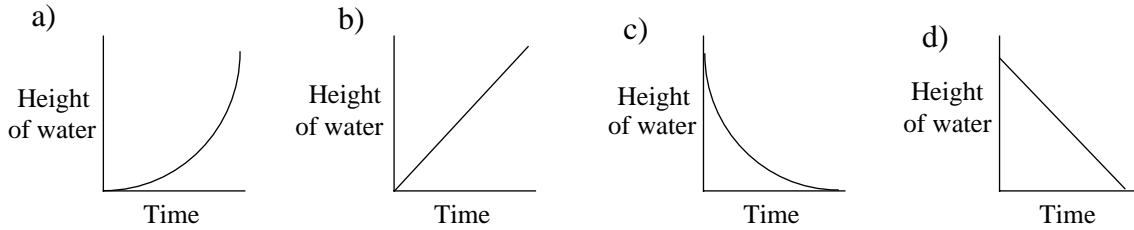

2) A car is bought for £5000. During each year it loses 20% of its value at the beginning of that year. (compound depreciation). Which of these diagrams represents its value?

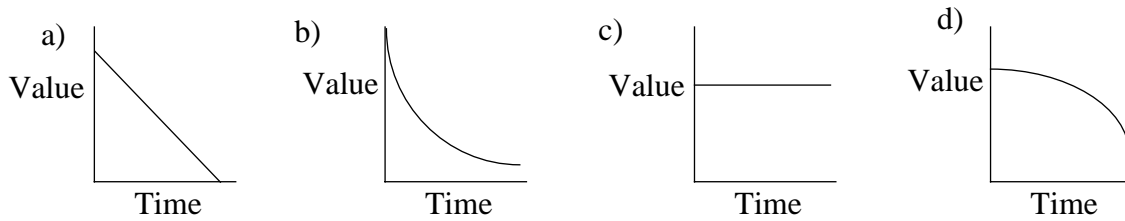

3) Niki travels to her gran's house. The first part of her journey she travels by bike, the second part she walks, and the last part she goes by bus. Which of these diagrams represents her journey?

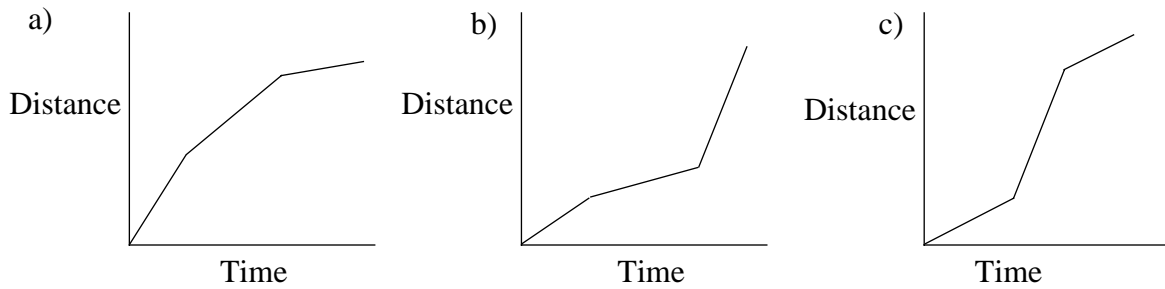

4) The table below shows the volume of some cubes. Sketch a graph of the length of their side against their volume.

Length of side (cm)	1	2	5	10	20
Volume of cube (cm ³)	1	8	125	1000	8,000

49. Recognising Graphs

Below there are 12 sketches of graphs and 12 functions representing them. Write down the letter of the function which goes with its graph.

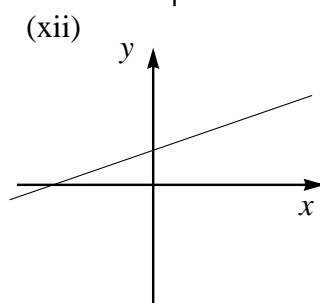
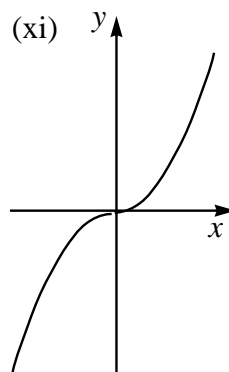
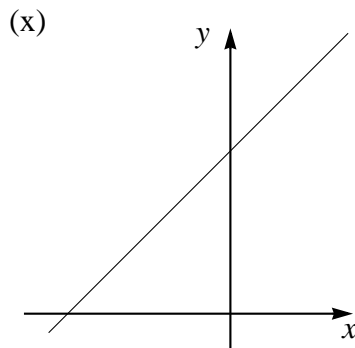
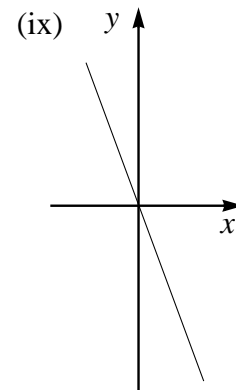
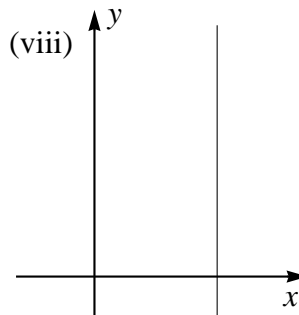
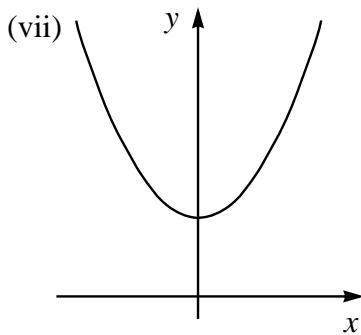
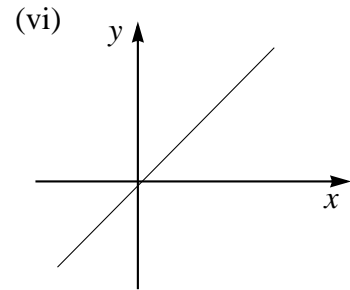
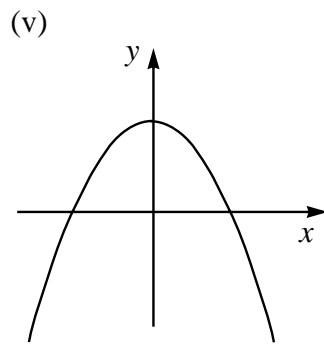
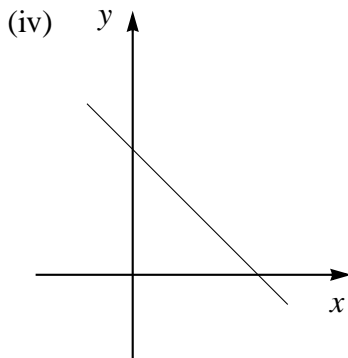
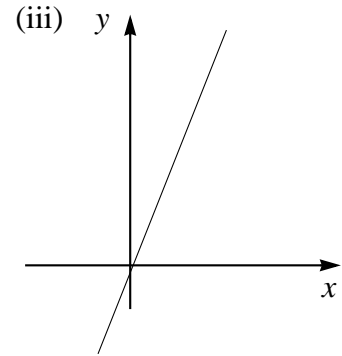
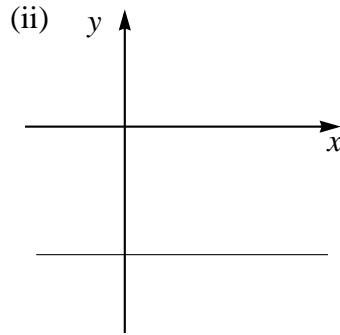
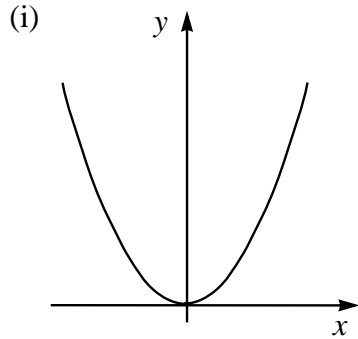

- a) $y = -5$ b) $y = x^2$ c) $y = x + 5$ d) $y = x^3$ e) $y = \frac{1}{2}x + 1$ f) $y = x^2 + 4$
 g) $y = x$ h) $y = -x^2 + 5$ i) $y = 2x$ j) $x = 6$ k) $y = -2x$ l) $y = -x + 4$

50. Plotting Graphs 1

- 1) The table shows some of the values of x and y for the equation $y = x + 3$.

x	1	2	3	4	5
y	4		6		

Complete the table.

- a) Plot the graph of $y = x + 3$. Use the scales of 2cm for 1 unit on the y axis and 2cm for 1 unit on the x axis.
 - b) Plot the points A(3,2) and B(5,4). draw the line AB. What can you say about the line AB and the line $y = x + 3$.
- 2) The line $y = x^2 + 2$ can be plotted from the points given in the following table..

x	1	2	3	4	5	6
y	3	6	11	18	27	38

- a) Plot the graph of $y = x^2 + 2$. Use the scale of 2cm to represent 1 unit on the x axis and 2cm to represent 5 units on the y axis.
 - b) from the graph estimate the value of y when $x = 4.5$
- 3) Complete the table of values for the equation $y = \frac{1}{2}x$.

x	2	4	6	8	10
y	1		3		

- a) Plot the graph of $y = \frac{1}{2}x$. Use the scales of 2cm to represent 2 units on the x axis and 2cm to represent 1 unit on the y axis
 - b) Plot the points A(2,5) and B(6,3) and join them with a straight line.
 - c) Complete this statement: "line AB is to the line $y = \frac{1}{2}x$."
- 4) Complete the table of values for the equation $y = \frac{1}{2}x + 2$.

x	0	2	4	6	8	10
y		3		5		

- a) Plot the graph of $y = \frac{1}{2}x + 2$. Use the scales of 2cm to represent 2 units on the x axis and 2cm to represent 1 unit on the y axis.
 - b) On the same axes, plot the graph of $y = \frac{1}{2}x$.
 - c) Complete this statement: "The line $y = \frac{1}{2}x + 2$ is to the line $y = \frac{1}{2}x$ "
- 5) Complete the table of values for the equation $y = 3x + 1$.

x	-2	-1	0	1	2
y				4	

- a) Plot the graph of $y = 3x + 1$. Use the scales of 4cm to represent 1 unit on the x axis and 2cm to represent 1 unit on the y axis
 - b) From your graph, estimate the value of x when $y = 3$.
- 6) Complete the table of values for the equation $y = x^2$.

x	-3	-2	-1	0	1	2	3
y	9				1		

- a) Plot the graph of $y = x^2$. Use the scales of 2cm to represent 1 unit on the x axis and 2cm to represent 1 unit on the y axis.
- b) On the same axes, draw the graph of $y = x + 2$.
- c) What are the co-ordinates of the points of intersection of the two graphs.

51. Plotting Graphs 2

- 1) a) Complete the table below which gives the values of $y = x^2 + 3$ for values of x ranging from -3 to $+3$.

x	-3	-2	-1	0	1	2	3
y	12		4	3		7	

- b) On graph paper, draw the graph of $y = x^2 + 3$. Use the scale of 2cm to 1 unit on the x axis and 2cm to 2 units on the y axis.
- c) From your graph determine, correct to 1 decimal place, the values of x when $y = 6$
- d) Draw the line $y = 7$ on the same graph and write down the co-ordinates of the points where they cross.
- 2) a) Complete the table below which gives the values of $y = 2x^2 + 3x - 1$ for values of x ranging from -3 to $+2$.

x	-3	-2	-1	0	1	2
y		1	-2			13

- b) On graph paper, draw the graph of $y = 2x^2 + 3x - 1$. Use the scale of 2cm to 1 unit on the x axis and 2cm to 2 units on the y axis.
- c) Draw the line $y = x + 3$ on the same graph and write down the co-ordinates of the points where they cross.
- d) Show that the solution to the equation $2x^2 + 2x - 4 = 0$ can be found at these points. Write down the solution to this equation
- 3) a) Complete the table below which gives the values of $y = x^3 + 6$ for values of x ranging from -1.5 to $+1.5$.

x	-1.5	-1	-0.5	0	0.5	1	1.5
y		5		6		7	

- b) On graph paper, draw the graph of $y = x^3 + 6$. Use the scale of 4cm to 1 unit on the x axis and 2cm to 1 unit on the y axis.
- c) Draw the line $y = x + 6$ on the same graph and write down the co-ordinates of the points where they cross.
- d) Show that the solution to the equation $x^3 - x = 0$ can be found at these points. Write down the solution to this equation
- 4) a) Complete the table below which gives the values of $y = 3x^2 - 6$ for values of x ranging from -3 to $+3$.

x	-3	-2	-1	0	1	2	3
y	21		-3	-6			

- b) On graph paper, draw the graph of $y = 3x^2 - 6$. Use the scale of 2cm to 1 unit on the x axis and 2cm to 5 units on the y axis.
- c) Draw the line $y = 10$ on the same graph and write down the co-ordinates of the points where they cross, correct to 1 decimal place.
- d) Show that the solution to the equation $3x^2 - 16 = 0$ can be found at these points. Write down the solution to this equation

52. Plotting Graphs 3

- 1) a) Complete the table below which gives the values of $y = 5 + \frac{2}{x}$ for values of x ranging from 0.5 to 8.

x	0.5	1	2	4	5	8
y		7		5.5	5.4	

- b) On graph paper, draw the graph of $y = 5 + \frac{2}{x}$. Use the scale of 2cm to 1 unit on the x axis and 2cm to 1 unit on the y axis.
- c) From your graph determine, correct to 1 decimal place, the value of x when $y=6.5$.
- d) Draw the line $y = 8 - \frac{x}{2}$ on the same graph and write down the co-ordinates of the points where they cross, correct to 1 decimal place.
- e) Show that the solution to the equation $\frac{x}{2} - 3 + \frac{2}{x} = 0$ can be found at these points. Write down the solution to this equation.

- 2) a) Complete the table below which gives the values of $y = x^2 + 2x + 5$ for values of x ranging from -3 to $+2$.

x	-3	-2	-1	0	1	2
y	8		4	5		

- b) On graph paper draw the graph of $y = x^2 + 2x + 5$. Use the scale of 2cm to 1 unit on the x axis and 2cm to 2 units on the y axis.
- c) By drawing a suitable straight line on the grid, solve the equation $x^2 + x + 5 = 7$
- 3) a) Complete the table below which gives the values of $y = 2x^3 - 5$ for values of x ranging from -1.5 to $+2$.

x	-1.5	-1	-0.5	0	0.5	1	1.5	2
y	-11.75			-5	-4.75	-3	1.75	

- b) On graph paper, draw the graph of $y = 2x^3 - 5$. Use the scale of 4cm to 1 unit on the x axis and 2cm to 2 units on the y axis.
- c) By drawing a suitable straight line on the grid, solve the equation $2x^3 - 4x - 1 = 0$

- 4) a) Complete the table below which gives the values of $y = \frac{5}{x} - 4$ for values of x ranging from 0.5 to 8.

x	0.5	1	2	5	8
y		1		-3	

- b) On graph paper, draw the graph of $y = \frac{5}{x} - 4$. Use the scale of 2cm to 1 unit on the x axis and 2cm to 1 unit on the y axis.
- c) By drawing a suitable straight line on the grid, solve the equation $x - 7 + \frac{5}{x} = 0$

53. Straight Line Graphs and Simultaneous Equations

Exercise 1

Draw the graph of each of the following equations

- | | | |
|-----------------------------|-----------------------------|-----------------------------|
| 1) $y = x + 1$ | 2) $y = x + 3$ | 3) $y = x + 4$ |
| 4) $y = x - 2$ | 5) $y = x - 6$ | 6) $y = x - 4$ |
| 7) $y = -x + 1$ | 8) $y = -x + 5$ | 9) $y = -x - 3$ |
| 10) $y = 2x + 1$ | 11) $y = 3x - 1$ | 12) $y = 4x - 6$ |
| 13) $y = -2x + 1$ | 14) $y = -3x - 4$ | 15) $y = -4x - 7$ |
| 16) $y = \frac{1}{2}x + 1$ | 17) $y = \frac{1}{3}x + 3$ | 18) $y = \frac{1}{2}x - 3$ |
| 19) $y = -\frac{1}{3}x - 2$ | 20) $y = -\frac{1}{2}x + 1$ | 21) $y = -\frac{1}{4}x + 7$ |
| 22) $y = 3 + x$ | 23) $y = 4 - x$ | 24) $y = -1 + x$ |
| 25) $y = 3 - \frac{x}{2}$ | 26) $y = 5 + \frac{x}{3}$ | 27) $y = 7 - \frac{x}{4}$ |
| 28) $3x + 2y = 6$ | 29) $4x + 5y = 20$ | 30) $6x + 4y = 24$ |
| 31) $4x - 5y = 0$ | 32) $6x - 3y = 0$ | 33) $4y - 3x = 0$ |
| 34) $x + 3 - y = 0$ | 35) $x - y - 2 = 0$ | 36) $4 + x - y = 0$ |
| 37) $2x + y - 2 = 0$ | 38) $y + 2x + 3 = 0$ | 39) $x + 2 - 2y = 0$ |

Exercise 2

Solve each of the following pairs of simultaneous equations by drawing them. All diagrams can be drawn on axes where x lies between -3 and 6 , and y lies between -4 and 6 .

- | | |
|--|--|
| 1) $y = x$ and $3x + 3y = 9$ | 2) $y = 4x$ and $2x + y = 6$ |
| 3) $3x + 2y = 12$ and $y = x + 1$ | 4) $y = \frac{1}{2}x + 3$ and $x + y = 6$ |
| 5) $y = x - 4$ and $y = -x$ | 6) $y = 2x + 2$ and $2x + y = 4$ |
| 7) $y = 3x - 3$ and $y = \frac{x}{2} + 2$ | 8) $x + y = 5$ and $y = \frac{x}{3} + 1$ |
| 9) $y = 2x + 4$ and $2x + 4y = 1$ | 10) $y - x = 0$ and $2y - x - 3 = 0$ |
| 11) $x + y + 2 = 0$ and $2y = x - 1$ | 12) $y = x + \frac{3}{2}$ and $2x + y = 6$ |
| 13) $2y = 3x - 3$ and $y = \frac{1}{3}x + 2$ | 14) $y = 2x + 5$ and $x + y = 2$ |

54. Inequalities

Solve these inequalities in the form $x \geq$ a number, $x \leq$ a number, $x >$ a number or $x <$ a number.

1) $x + 1 > 4$

2) $x + 2 < 5$

3) $7 < 2 + x$

4) $x + 2 < 8$

5) $x - 3 > 7$

6) $3 > x - 7$

7) $3x \geq 12$

8) $5x \geq -25$

9) $25 \geq 5x$

10) $2x + 1 \geq 7$

11) $3x - 6 < 6$

12) $3 < 6x + 39$

13) $6x - 26 \leq 10$

14) $5x + 5 \geq 40$

15) $3x + 7 < 40$

16) $6 > x - 3$

17) $12 < x + 20$

18) $15 > x + 7$

19) $14 + 3x \leq 38$

20) $18 + 2x < 60$

21) $15 + 3x \leq 45$

22) $x + 4 > 3x - 8$

23) $x - 3 > 2x + 11$

24) $x - 7 < 3x - 1$

25) $4x + 3 \geq 3x - 7$

26) $5x - 6 \leq 2x + 9$

27) $3x + 9 \geq 5x + 2$

28) $7x - 12 < 3x - 2$

29) $5x - 15 > 3x + 2$

30) $4x + 15 < 3x + 22$

31) $\frac{1}{2}x - 7 \leq 4$

32) $\frac{1}{3}x - 3 \leq 2$

33) $\frac{1}{8}x + 7 \leq 2$

34) $\frac{1}{4}x + 15 > 12$

35) $\frac{1}{5}x - 6 > 10$

36) $\frac{1}{6}x + 3 > 10$

37) $7 - \frac{1}{3}x \leq \frac{2}{3}x - 3$

38) $9 - \frac{4}{5}x > \frac{1}{5}x + 4$

39) $12 - \frac{3}{8}x > \frac{5}{8}x + 7$

40) $3(x + 2) > 12$

41) $2(x + 8) > 12$

42) $2(2x + 7) > 10$

43) $2(2x + 4) \leq -6$

44) $2(3x + 2) \leq 16$

45) $2(4x + 4) \leq 32$

46) $3x - 5 > 2(x + 1)$

47) $4x + 3 > 3(x + 4)$

48) $9x - 3 > 3(2x + 5)$

49) $4(x + 2) \leq 2x + 20$

50) $5(x - 7) \geq 3x + 15$

51) $6(x - 7) \leq 3x + 18$

55. Inequalities - Graphs

1)

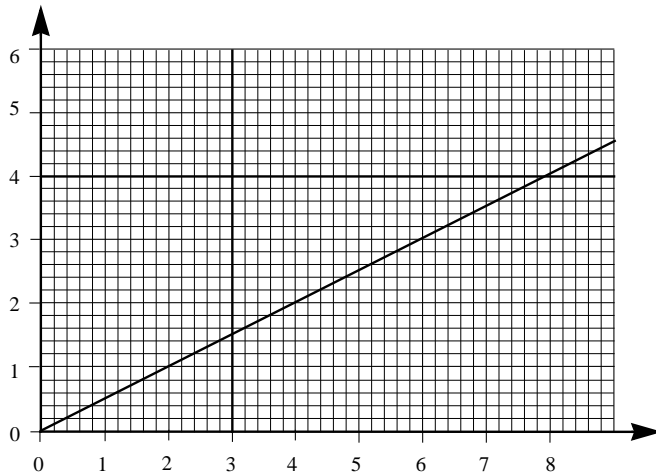

The diagram shows the graphs of $y = \frac{1}{2}x$, $y = 4$ and $x = 3$. From the diagram write down the co-ordinates of a point (x,y) which satisfies the inequalities $y > \frac{1}{2}x$, $y < 4$ and $x > 3$.

2)

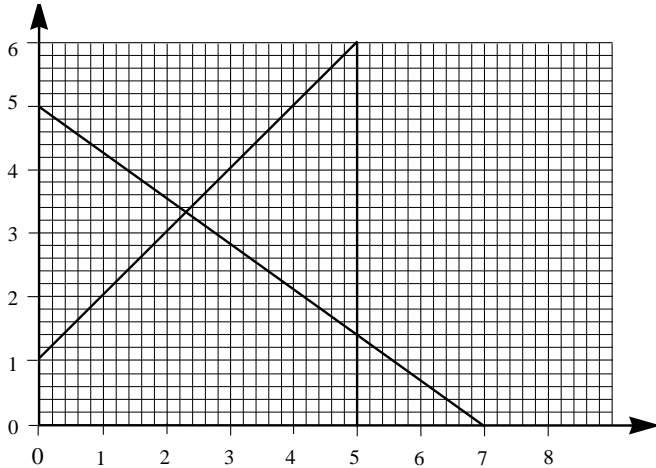

The diagram shows the graphs of $y = x + 1$, $7y + 5x = 35$ and $x = 5$. From the diagram write down a point (x,y) which satisfies the inequalities $y \leq x + 1$, $7y + 5x > 35$ and $x \leq 5$.

3) Using a scale of 0 to 8 on the x axis and 0 to 10 on the y axis, plot the following graphs; $y = x$, $y = 7$ and $y = 4$. Shade in the region which satisfies all the inequalities $y < x$, $x < 7$ and $y > 4$.

4) Using a scale of 0 to 9 on the x axis and 0 to 9 on the y axis, plot the following graphs; $y = x$, $y = 6$ and $8x + 8y = 64$. Shade in the region which satisfies all the inequalities $y > x$, $y < 6$ and $8x + 8y > 64$.

5) Using a scale of 0 to 8 on the x axis and 0 to 10 on the y axis, plot the following graphs; $y = \frac{1}{2}x$, $x = 2$ and $8x + 5y = 40$. Shade in the region which satisfies all the inequalities $y > \frac{1}{2}x$, $x \geq 2$ and $8x + 5y < 40$.

6) Using a scale of 0 to 8 on the x axis and -6 to 6 on the y axis, plot the following graphs; $y = x - 3$, $x = 6$ and $y = -x$. Shade in the region which satisfies all the inequalities $y < x - 3$, $x < 6$ and $y > -x$.

Which of the following points lie within this region? $(2,1)$, $(4,-2)$, $(5,2)$, $(5,1)$

7) Using a scale of 0 to 8 on the x axis and 0 to 8 on the y axis, plot the following graphs; $y = -\frac{1}{2}x + 3$, $x = 1$ and $7x + 6y = 42$. Shade in the region which satisfies all the inequalities $y \geq -\frac{1}{2}x + 3$, $x > 1$ and $7x + 6y < 42$.

Which of the following points lie within this region? $(2,4)$, $(5,4)$, $(3,3)$, $(4,1)$.

56. Angles

Calculate the sizes of the unknown angles in each of the following diagrams.

1)

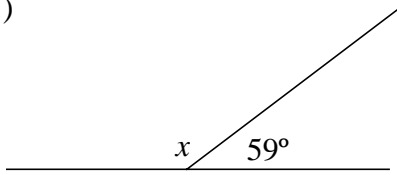

2)

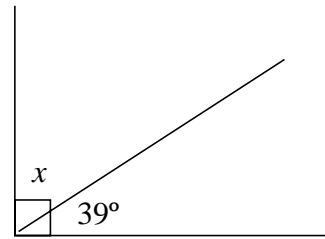

3)

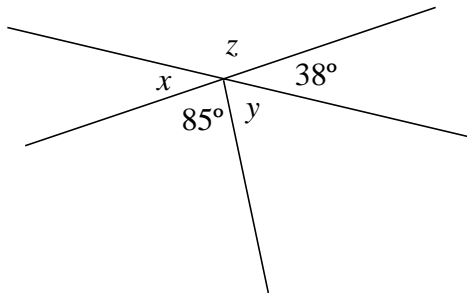

4)

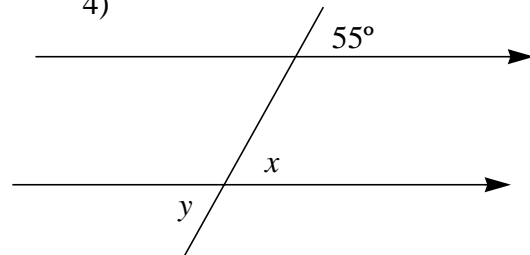

5)

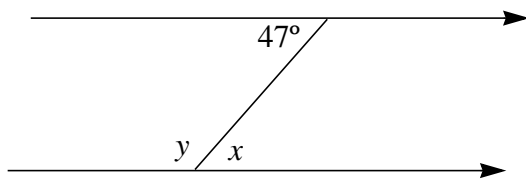

6)

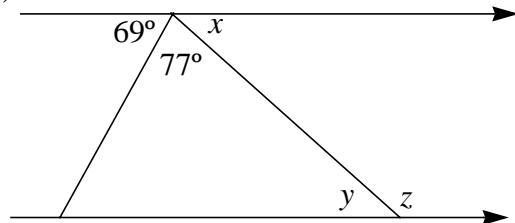

7)

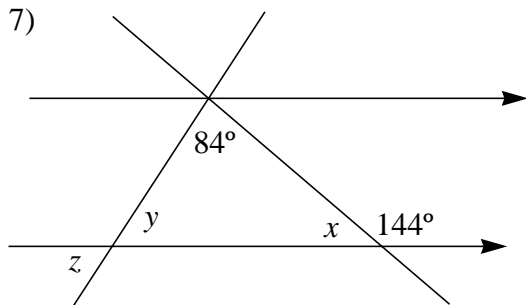

8)

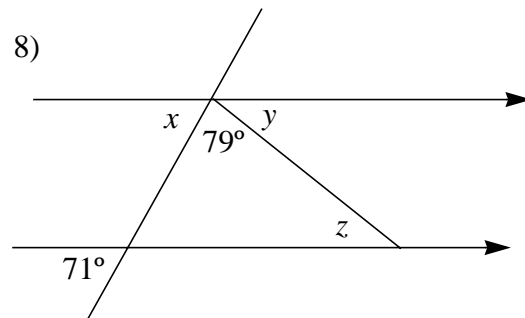

9)

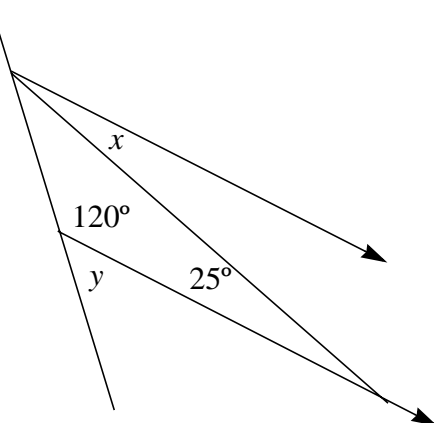

10)

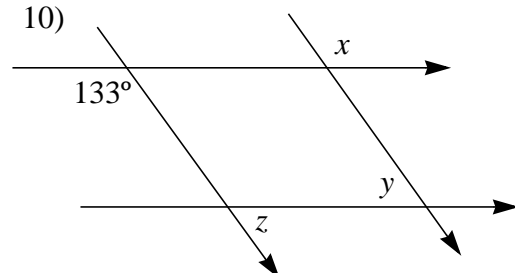

57. Triangles 1

Calculate the sizes of the unknown angles in each of the following diagrams.

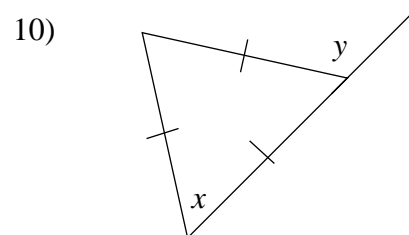
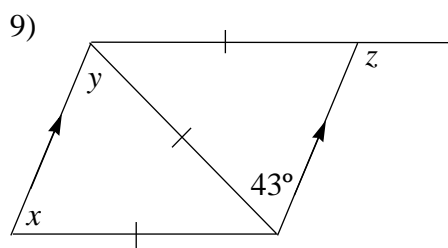
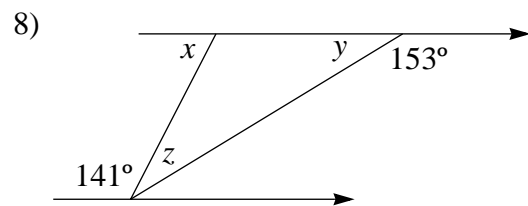
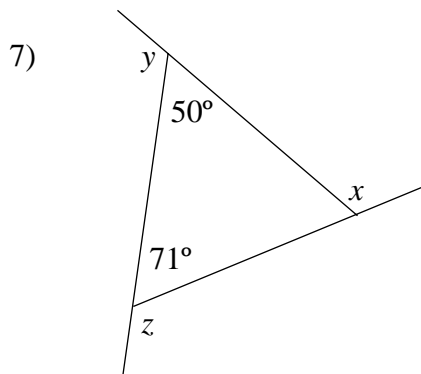
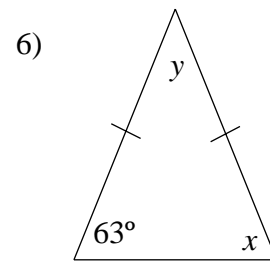
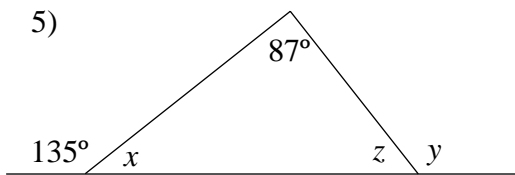
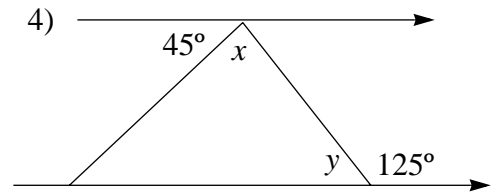
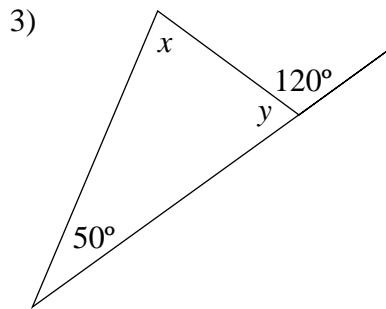
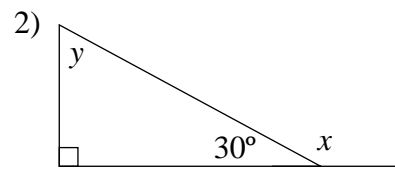
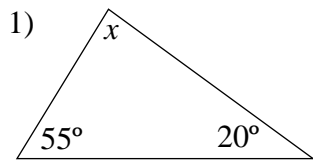

58. Triangles 2

Calculate the sizes of each of the marked angles.

1)

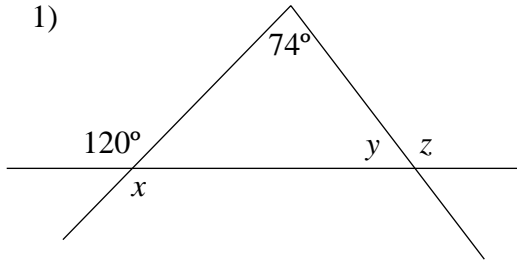

2)

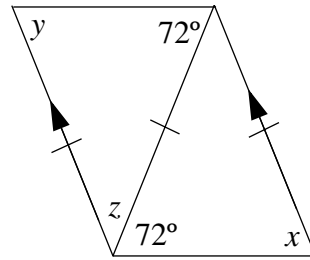

3)

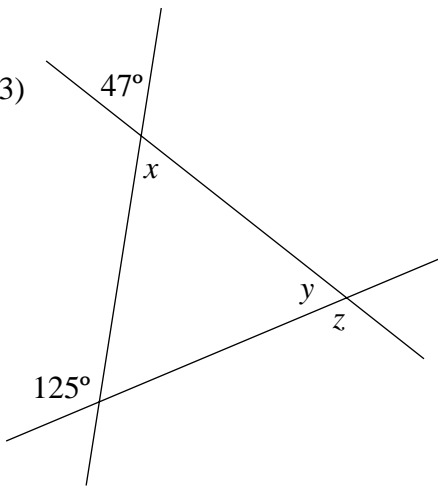

4)

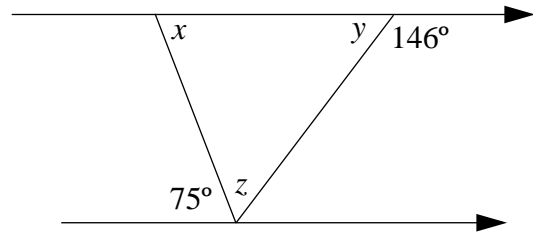

5)

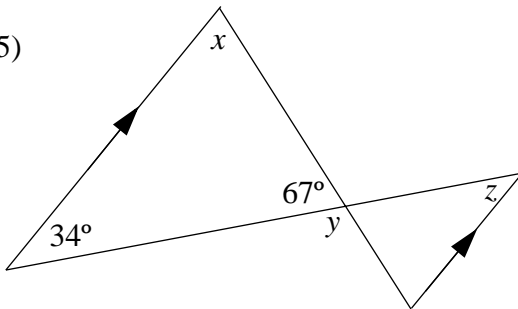

6)

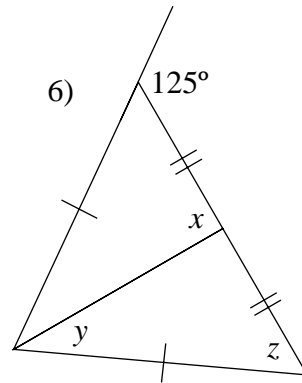

7)

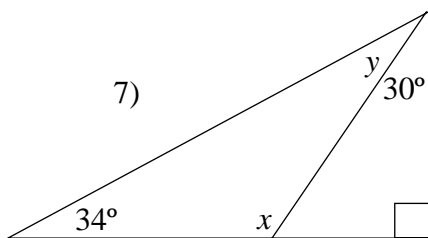

8)

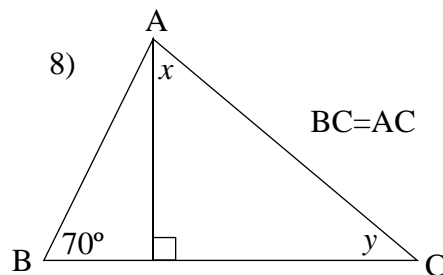

59. Shapes

Each of the diagrams below can be described by one of the given names.

Link the shape with a name in each case.

Square, Rectangle, Parallelogram, Octagon, Trapezium, Triangle, Triangular prism, Cube, Cylinder, Circle, Cone, Pentagon, Quadrilateral, Pyramid, Cuboid, Kite, Hexagon..

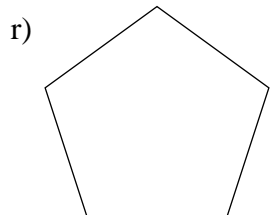
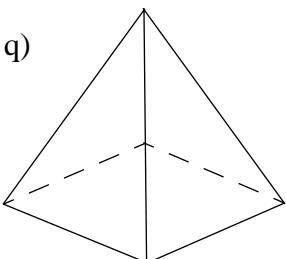
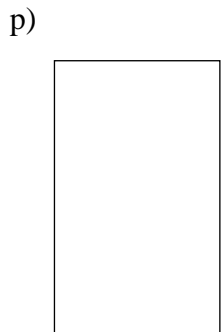
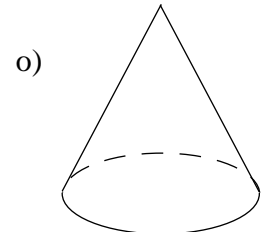
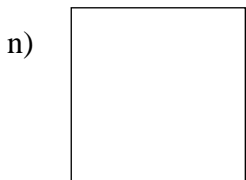
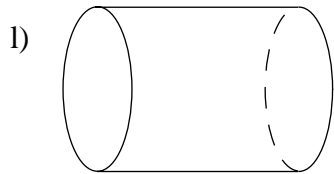
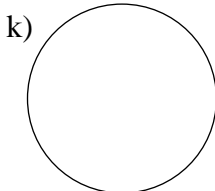
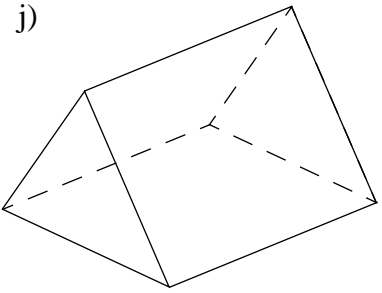
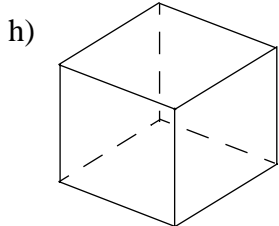
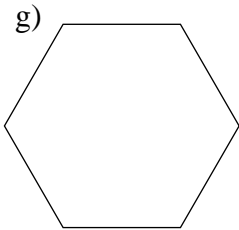
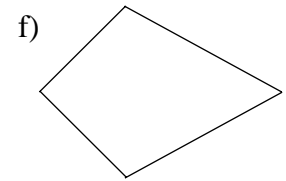
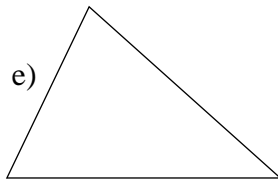
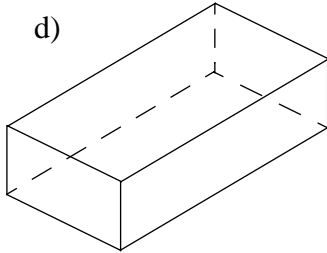
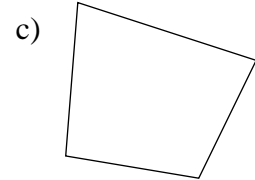
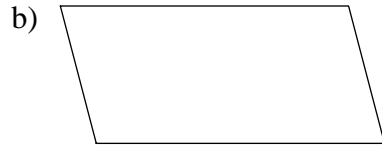
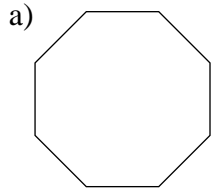

60. Quadrilaterals

1) Draw a sketch of each of the following quadrilaterals.

In each case show any lines of symmetry they may have.

- a) Square
- b) Rectangle
- c) Rhombus
- d) Parallelogram
- e) Trapezium

2) What are the sizes of angles x and y in this parallelogram?

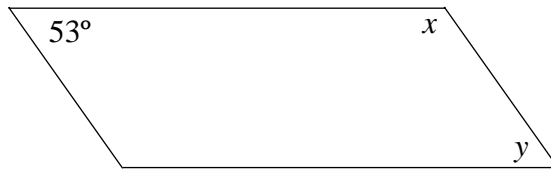

3) What are the sizes of the angles x and y in this rhombus.

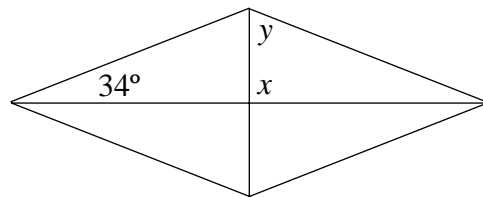

4) Calculate the size of the unknown angle in this quadrilateral.

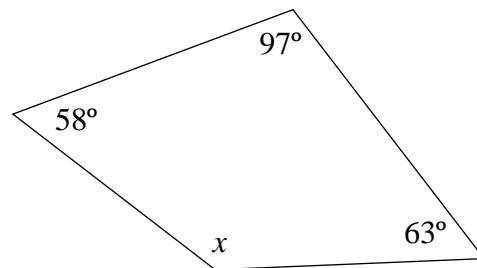

5) A quadrilateral has internal angles of 90° , 100° and 105° . What is the size of the fourth angle?

6) What is the size of angle x ?

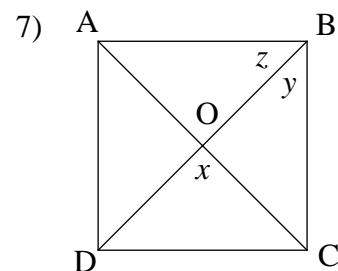
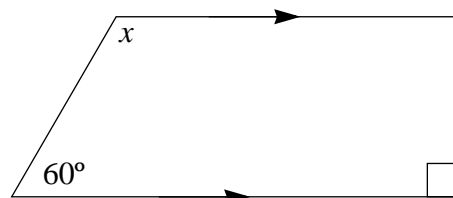

The diagram shows a square ABCD

O is the point where the diagonals cross.

- a) Name three triangles which are congruent to triangle BOC.
- b) What are the sizes of angles x , y and z ?

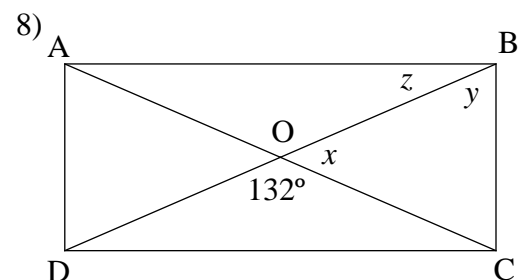

The diagram shows the rectangle ABCD.

O is the point where the diagonals cross.

- a) What special name is given to triangle BOC?
- b) Which triangle is congruent to triangle BOC?
- c) Name two other triangles which are congruent to each other.
- d) Calculate the sizes of angles x , y and z .

61. Regular Polygons

Make sketches of each of the following regular polygons.

- 1) A Pentagon
- 2) A Hexagon
- 3) A Heptagon
- 4) An Octagon
- 5)

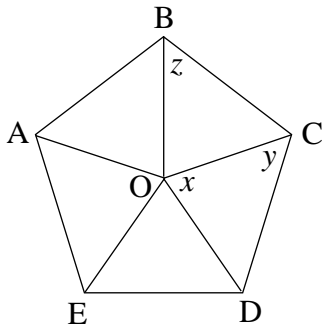

ABCDE is a regular pentagon.

O is the centre.

- a) What can you say about the lines OA, OB, OC, OD, OE?
- b) What is the size of angle x ?
- c) Calculate the sizes of angles y and z .

6)

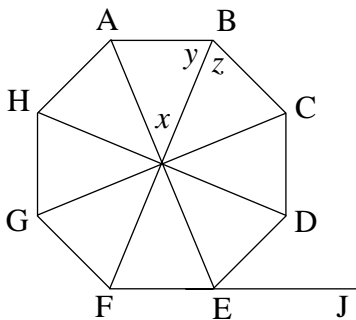

ABCDEFGH is a regular octagon.

- a) What is the size of angle x ?
- b) What are the sizes of angles y and z ?
- c) What is the size of angle ABC?
- d) What is the size of the exterior angle DEJ?

7)

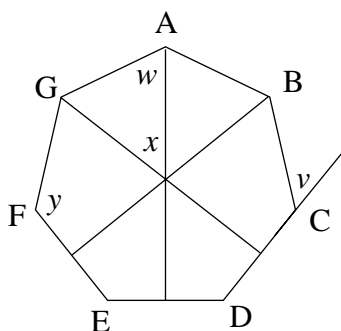

ABCDEFG is a regular heptagon.

Three lines of symmetry are shown.

- a) What is the size of angle x ?
- b) Calculate the size of angle w .
- c) Write down the size of angle y .
- d) What is the size of the exterior angle v ?

- 8) What is the order of rotational symmetry of a regular octagon?
- 9) Explain why a regular pentagon will not tessellate and a regular hexagon will.
- 10) How many lines of symmetry has a regular nonagon?

62. Irregular Polygons

- 1) A quadrilateral has internal angles of 90° , 100° and 105° . What is the size of the fourth angle?
- 2) A hexagon has angles of 100° , 110° , 115° , 130° and 140° . What is the size of the sixth angle?
- 3) An octagon has six angles of 145° . If the remaining two angles are equal, what is the size of them?
- 4) A heptagon has six angles each of 130° . What is the size of the other angle?
- 5) A decagon has two angles of the same size and a further eight angles of twice the size. What are the sizes of the angles?

- 6) What is the size of the angle x ?

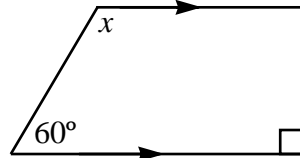

- 7) This hexagon is symmetrical about the line AD. The angles at A and B are 140° and 110° . If the side BC is parallel to FE and the angle at C is twice the angle at D, what are the sizes of the other angles?

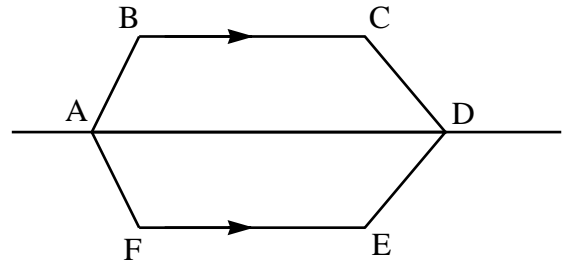

- 8) The pentagon ABCDE has three angles of 90° . If the other two angles are equal, what are their size?

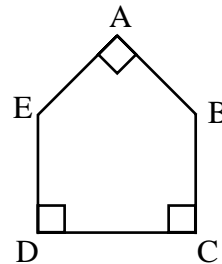

- 9) In the diagram, the octagon has two lines of symmetry. There are two different sizes of angle in the shape. If one of them is 130° , what is the other?

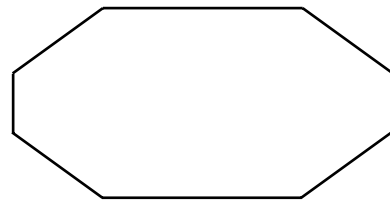

- 10) The diagram shows the cross section of a steel bar. It is symmetrical about the line AB. If it has six interior angles of 90° and another of 160° , what are the sizes of the other interior angles?

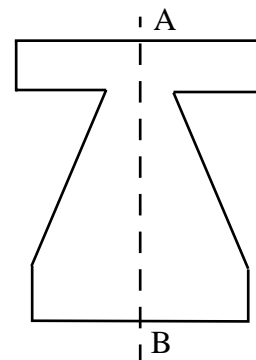

63. Congruency

Do not use a ruler or protractor in any of these questions

1) These two triangles are congruent. Answer the following questions about them.

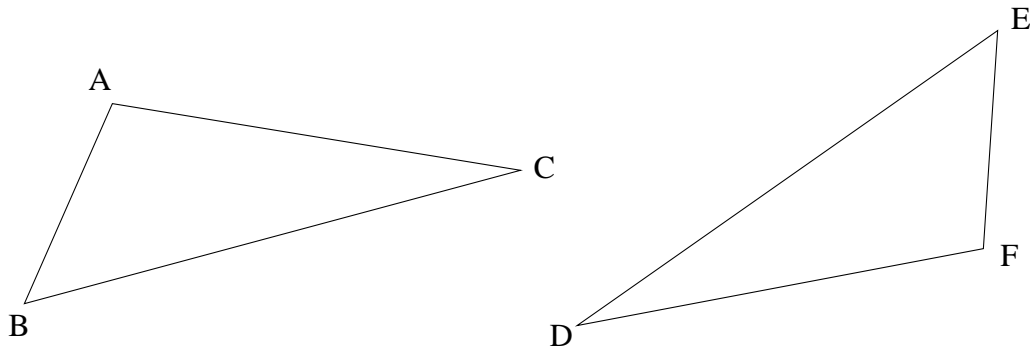

- Which other angle is equal to angle ABC?
- Which other angle is equal to angle EFD?
- Which side in triangle DEF is equal to side AC?
- Which of the following statements are true about the two triangles?
 - $AB > FD$
 - Angle $ACB \neq$ angle EDF
 - The angle opposite side $CB =$ The angle opposite side ED
 - The area of triangle $ABC =$ The area of triangle DEF

2) Congruent triangles can be constructed by joining together the ends of parallel lines of equal length, like this -

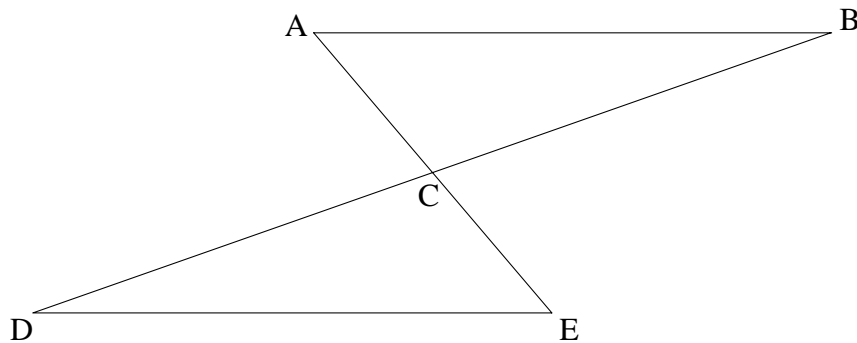

- Which angles are equal to each other?
- Which lengths are equal to each other?

3) Triangles can be proved to be congruent when corresponding angles and sides in one are equal to those in the other. State which of the following will show congruency and which will not.

- All three sides in the first triangle are the same lengths as the three sides in the second.
- All three angles in the first triangle are equal to the three angles in the second.
- Two sides and the included angle in the first triangle are equal to two sides and the included angle in the second triangle.
- One side and two angles in the first triangle are equal to one sides and two angles in the second triangle

64. Tessellatons

1) On the appropriate spotty paper, tessillate each of these shapes six more times.

a)

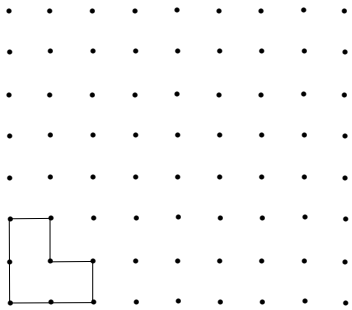

b)

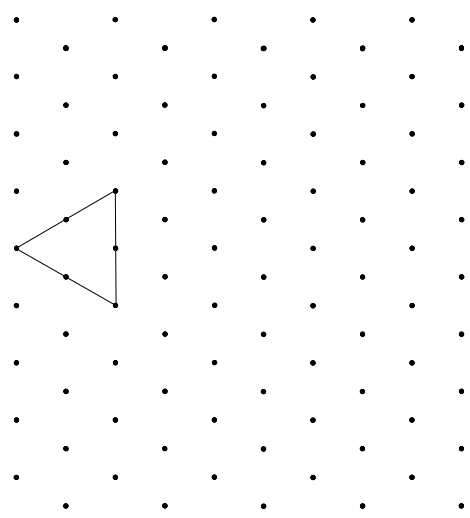

c)

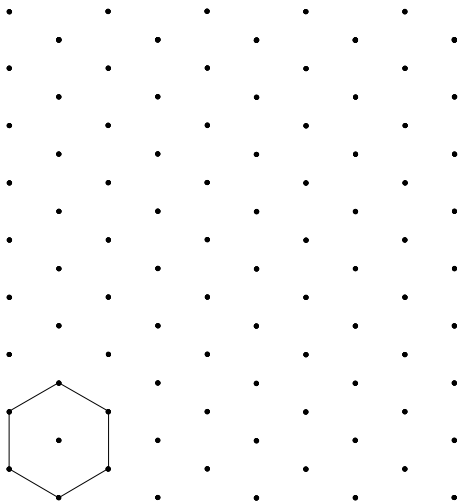

d)

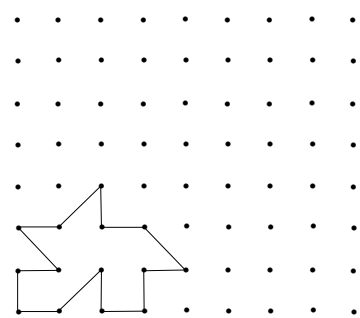

2) The interior angle of a square is 90° . The interior angle of a regular octagon is 145° . Explain why squares tessellate but regular octagons do not.

3) The diagrams show how regular octagons, pentagons and heptagons tessellate. What are the names of the spaces left between them?

a)

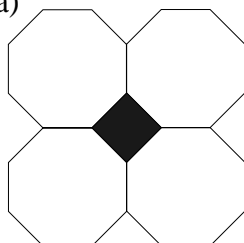

b)

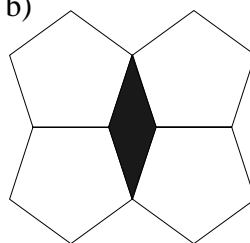

c)

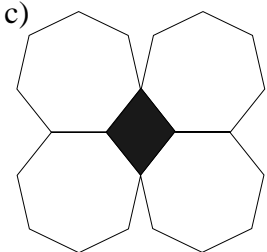

65. Nets and Isometric Drawings 1

1) Which of these shapes represent the net of a cuboid?

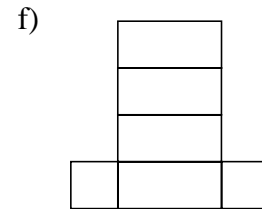
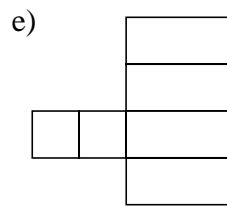
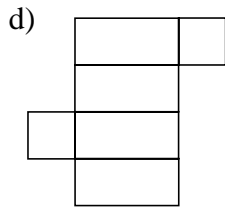
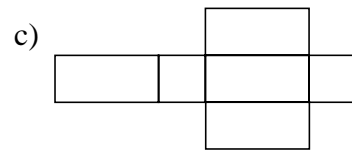
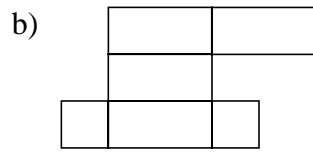
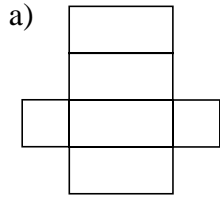

2) The diagram shows part of a cuboid. Complete it on isometric paper.

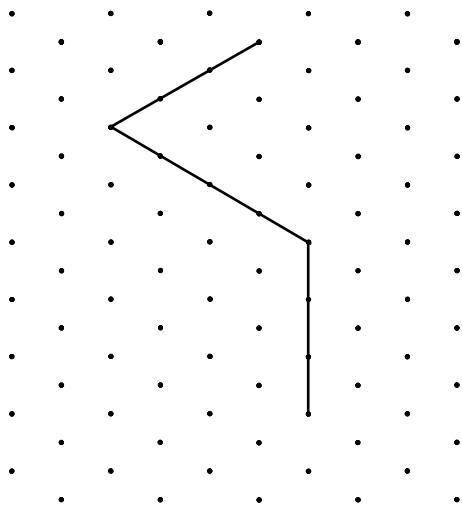

3) The diagram shows a cuboid. It measures 4cm by 4cm by 3cm. Draw its net.

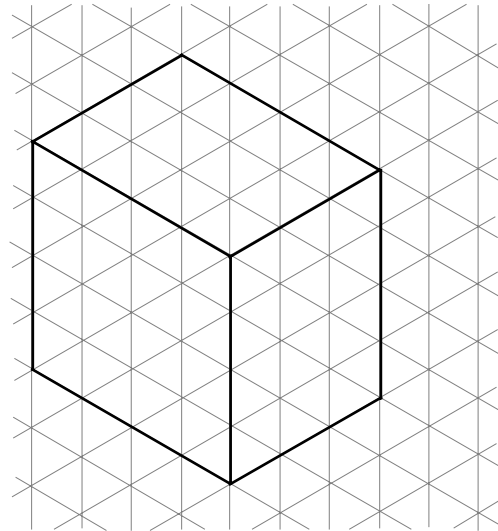

4) This is part of the net of a triangular pyramid. Complete it on isometric paper.

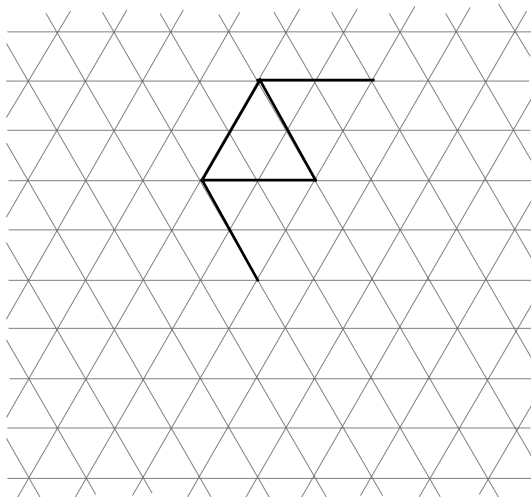

5) The diagram shows part of a square based pyramid. Complete it on isometric paper.

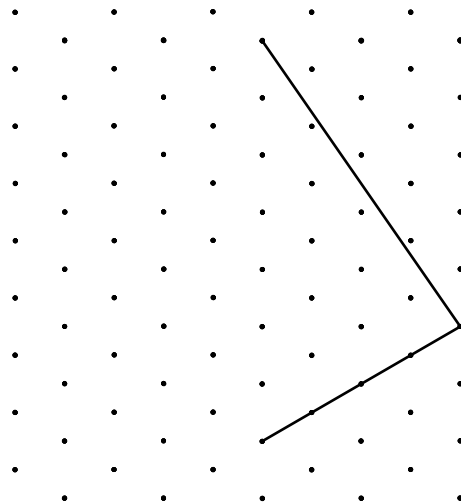

66. Nets and Isometric Drawing 2

1) Draw the net of this 3cm cube.

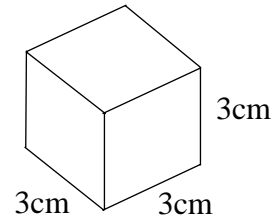

2) A cubic box has a square hole in the middle of two opposite faces. Draw a sketch of its net.

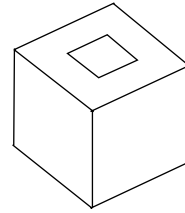

3) A cube has the numbers 1 to 6 painted on its sides. The numbers on opposite sides always add up to 7.

- a) What number is opposite 1?
- b) What numbers are opposite 3 and 5?

Sketch a net of the cube and put on the numbers

4) Sketch a net of this cuboid. Show clearly the darkened corner.

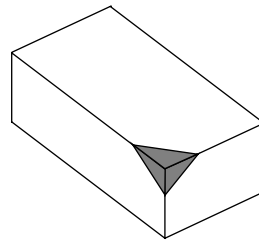

5) a) Sketch the net of this triangular prism (i)
The net has its front edge cut away, as shown in diagram (ii).
b) Sketch the net of this shape.

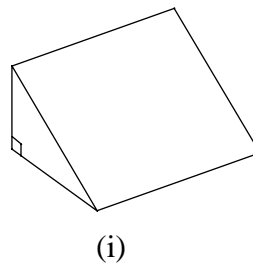

(i)

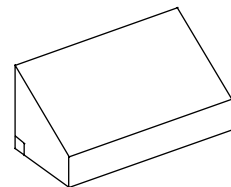

(ii)

6) The first diagram shows a square based pyramid.

- a) Sketch the net of its shape.
- The top of the pyramid is cut off at an angle, as shown in the second diagram.

b) Sketch the net of this new shape.

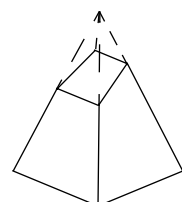
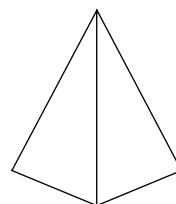

67. Reflection Symmetry

1) Which of these lines have one ore more lines of symmetry?

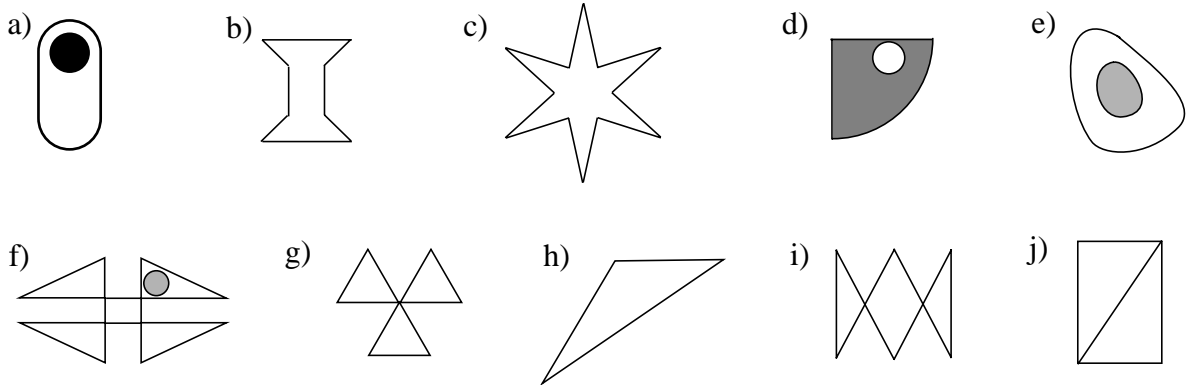

2) Reflect this shape about the line AB

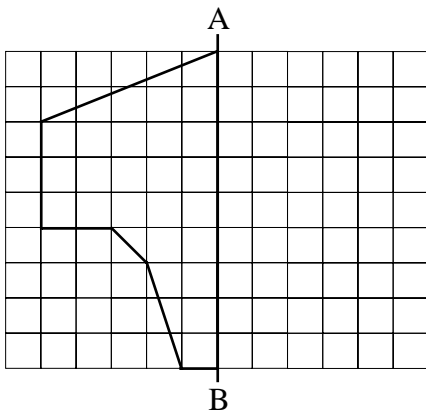

3) Reflect this shape about the mirror line

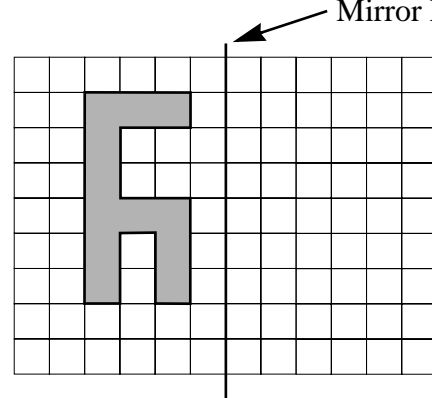

4) In which position do the four tiles have to be placed in order to make the dark tiles symmetrical?

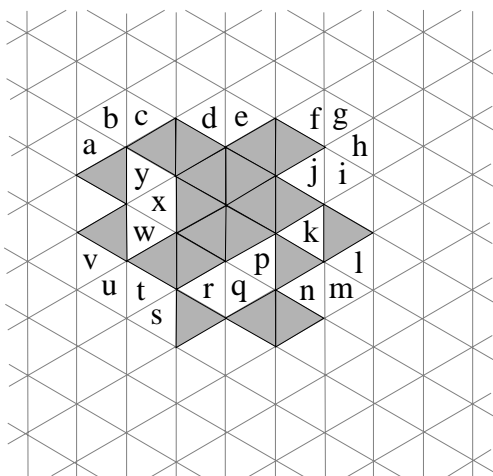
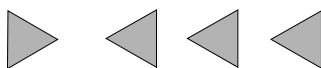

5) The diagram is reflected in the line AB and then in the line XY. Draw the result.

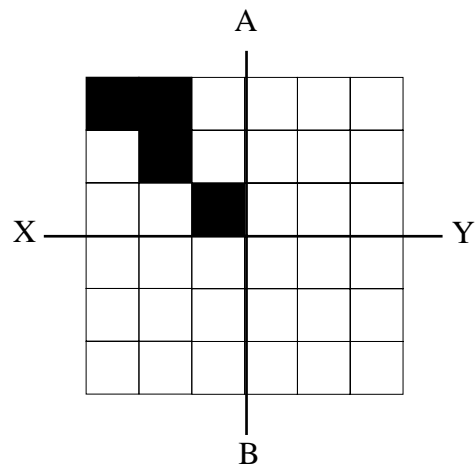

68. Reflections

- 1) Reflect the triangle about the y axis. What are the co-ordinates of the new shape?

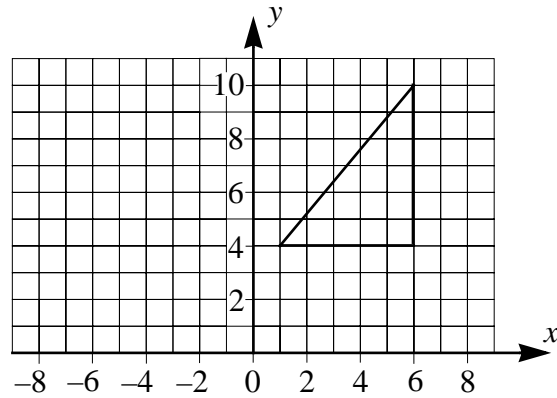

- 2) Reflect the shape about the line $x = 2$. What are the co-ordinates of the new shape?

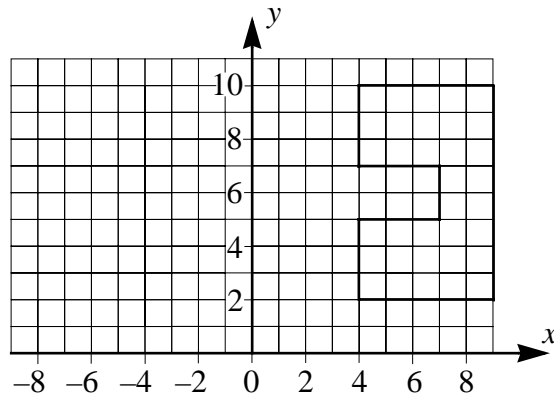

- 3) Reflect the rhombus about the line $x = -1$. What are the co-ordinates of the new shape?

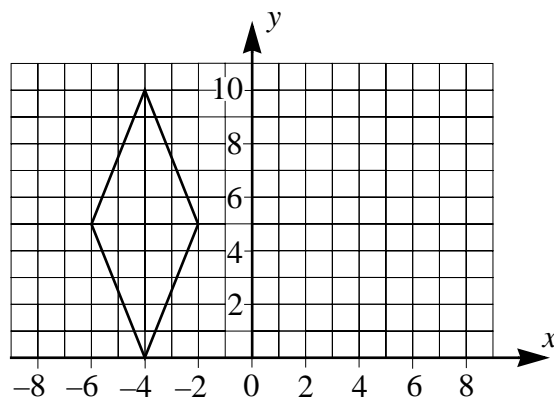

- 4) Reflect the triangle below about the x axis. What are the co-ordinates of the new shape?

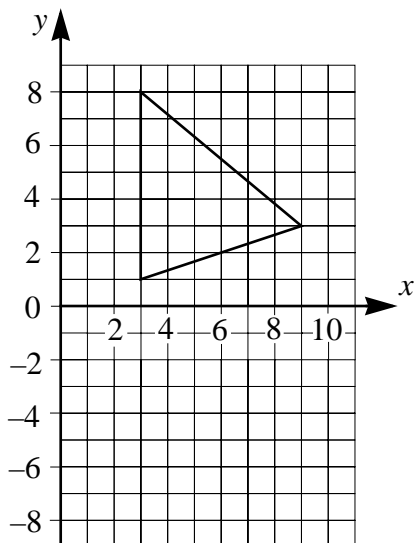

- 5) Reflect the parallelogram about the line $y = 2$. What are the co-ordinates of the new shape?

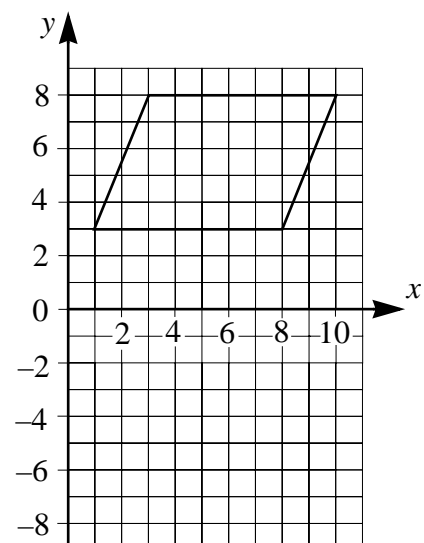

69. Enlargements

1) Enlarge this shape using a scale factor of 3. Line AB is shown enlarged.

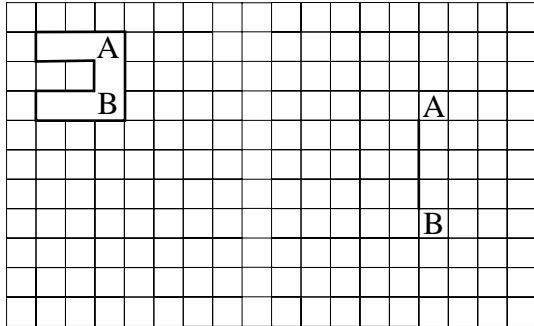

2) Enlarge shape E using a scale factor of 2. Line AB represents one side of the new shape.

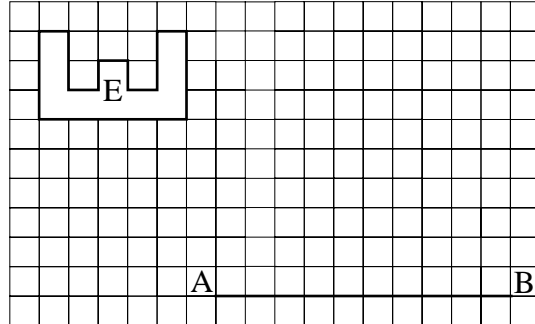

3) Enlarge this shape with a scale factor of 3.

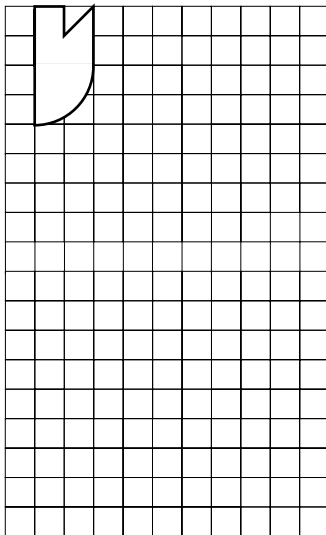

4) Enlarge this shape with a scale factor of 2.

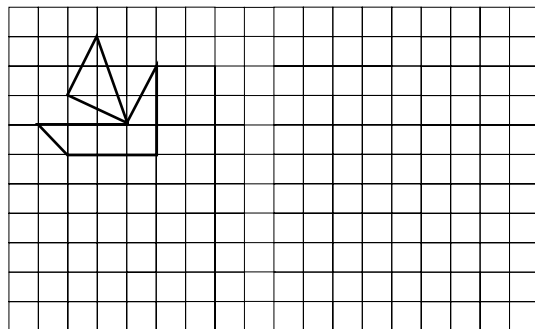

5) Enlarge this shape with a scale factor of 3.

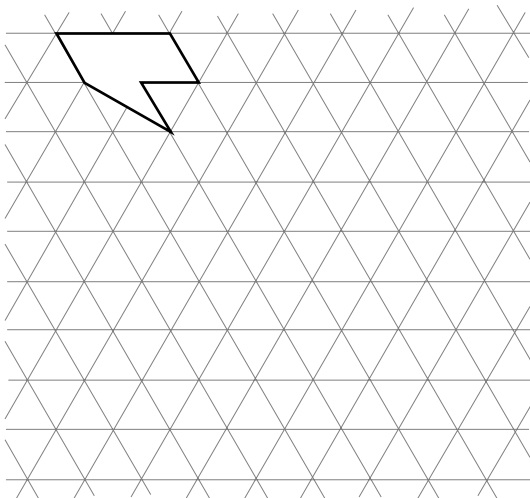

6) Enlarge this shape with a scale factor of 2.

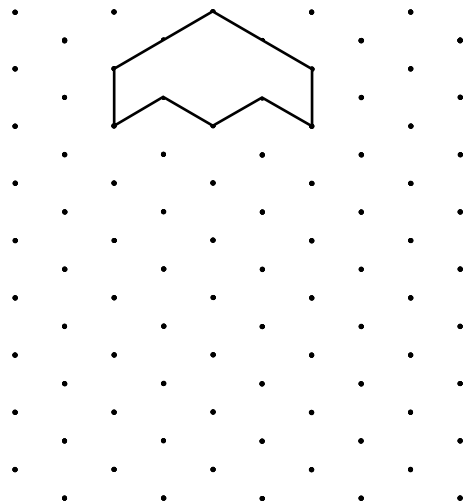

70. Rotational Symmetry

1) Each of the following shapes has rotational symmetry.
What is the order of their symmetry?

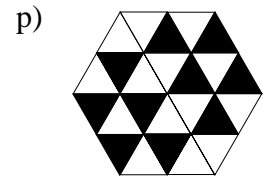
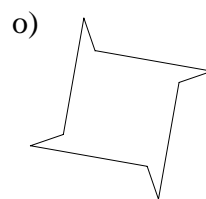
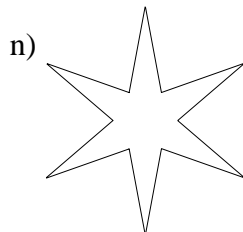
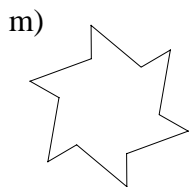
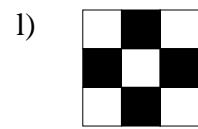
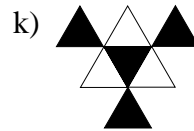
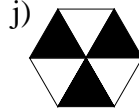
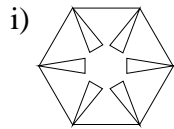
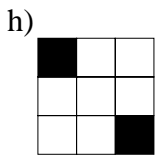
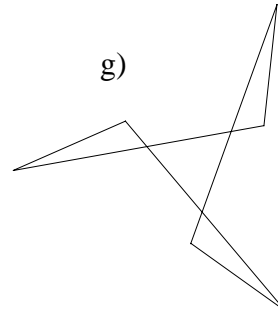
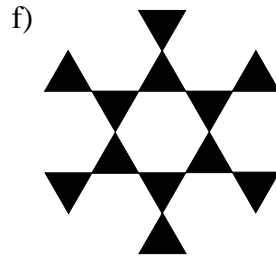
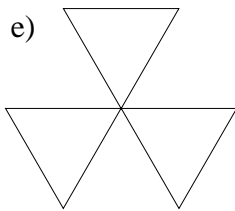
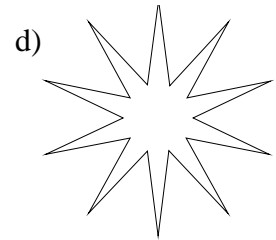
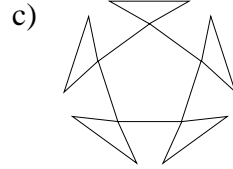
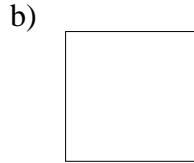
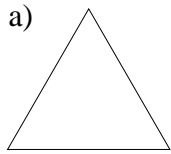

2) Which of these letters have rotational symmetry?

A C D I M N S T U V W X Y Z

3) Rotate each of the following designs 90° clockwise about the point P.
Sketch the result. The first has been done for you.

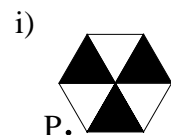
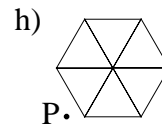
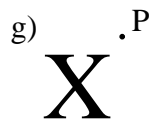
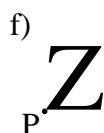
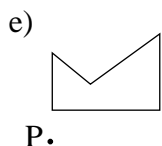
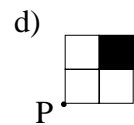
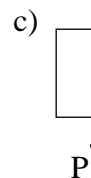
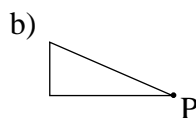
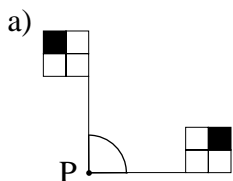

71. Rotation

- 1) Rotate the triangle 180° about $(0,0)$.
What are the co-ordinates of the new triangle?

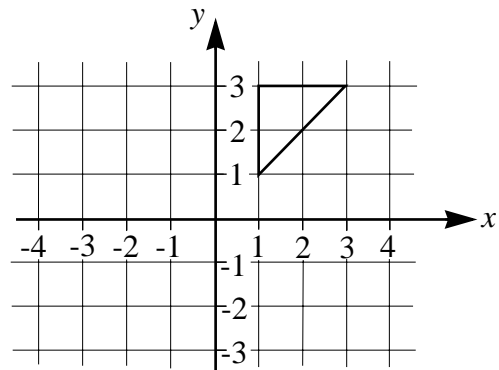

- 2) Rotate the triangle 90° clockwise about $(0,0)$. What are the co-ordinates of the new triangle?

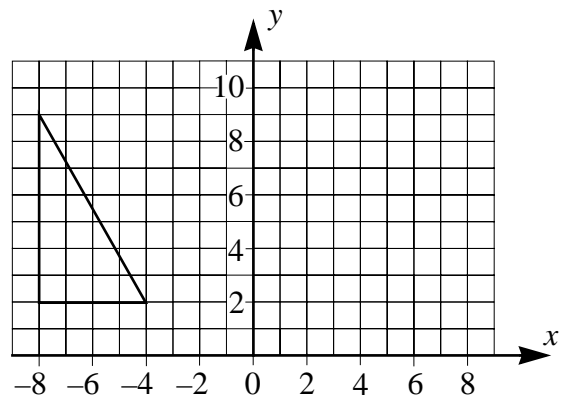

- 3) Rotate the rectangle 90° anticlockwise about the point $(0,0)$. What are the co-ordinates of the new rectangle?

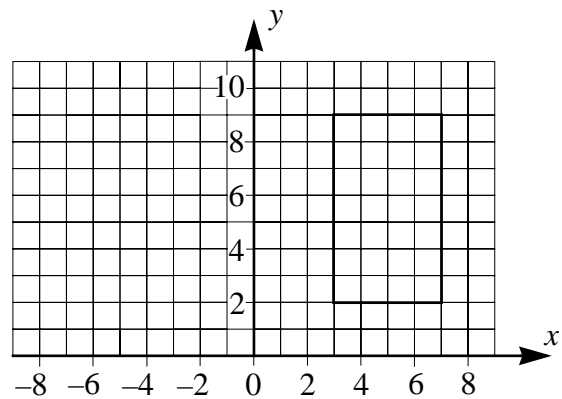

- 4) Describe fully the transformation which maps shape A onto shape B.

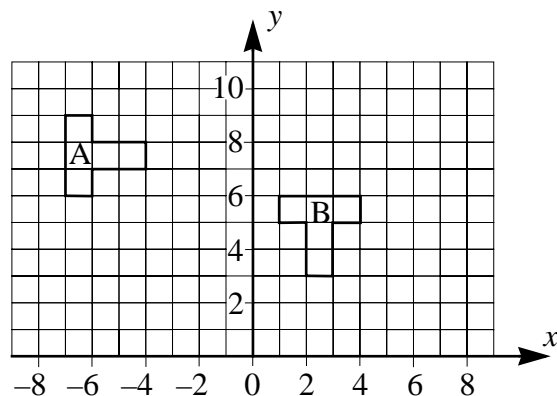

72. Translations 1

- 1) The triangle is translated 8 units to the right. Draw the new shape. What are the co-ordinates of the new shape.

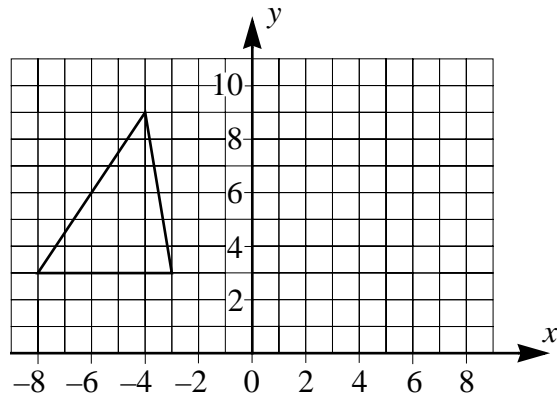

- 2) The parallelogram is translated 8 units to the left. Draw the new shape. What are the co-ordinates of the new shape?

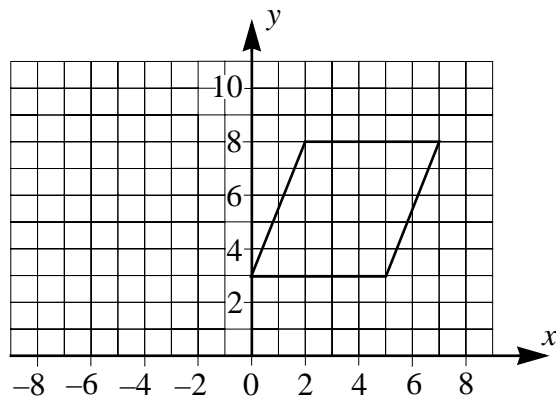

- 3) The trapezium is translated 7 units down the page. Draw the new shape. What are the co-ordinates of the new shape?

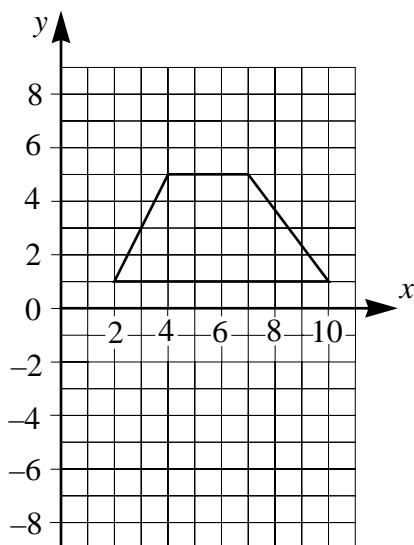

- 4) The pentagon is translated 10 units up the page. Draw the new shape. What are the co-ordinates of the new shape.

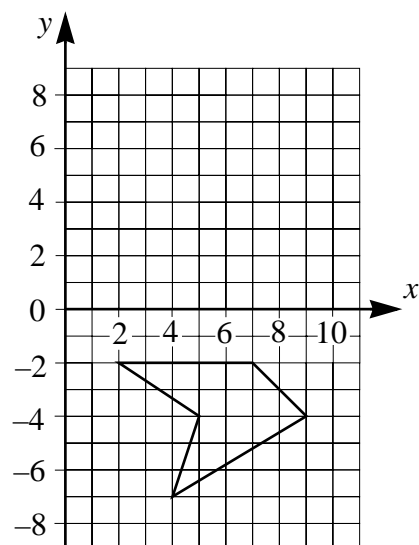

73. Translations 2

1) The diagram shows a triangle A,B,C.

Copy this diagram.

- Translate the shape 6 units in the x direction.
- Translate the new shape 4 units in the y direction.
- What are the co-ordinates of the final shape.

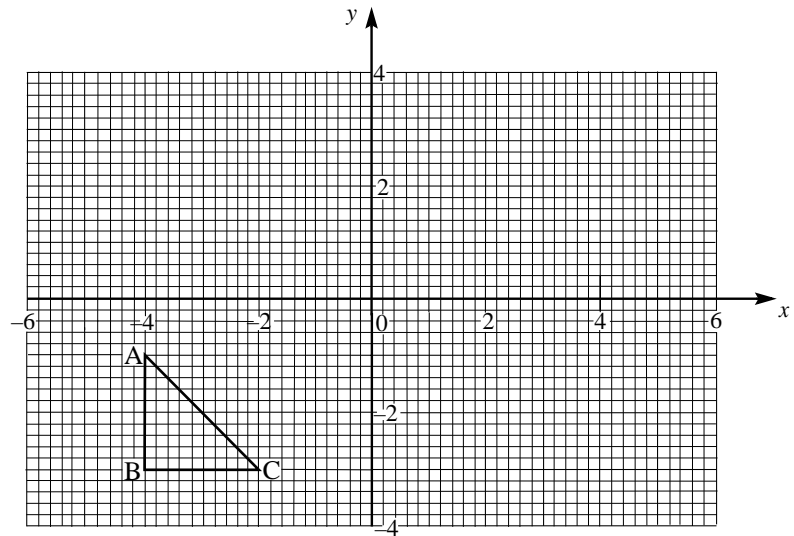

2) The diagram shows a square A,B,C,D.

Copy this diagram.

- Translate the shape 6 units in the x direction.
- Translate the new shape -5 units in the y direction.
- What are the co-ordinates of the final shape.

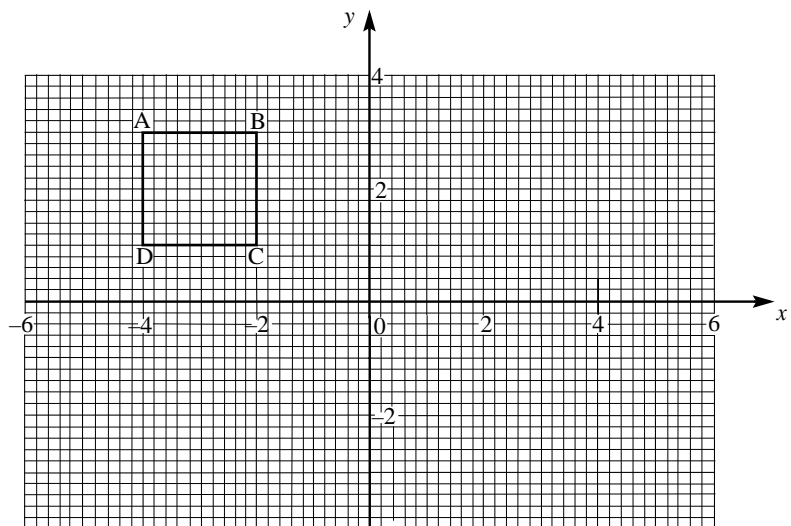

3) The diagram shows a quadrilateral A,B,C,D.

Copy this diagram.

- Translate the shape -6 units in the x direction.
- Translate the new shape -4 units in the y direction.
- What are the co-ordinates of the final shape.

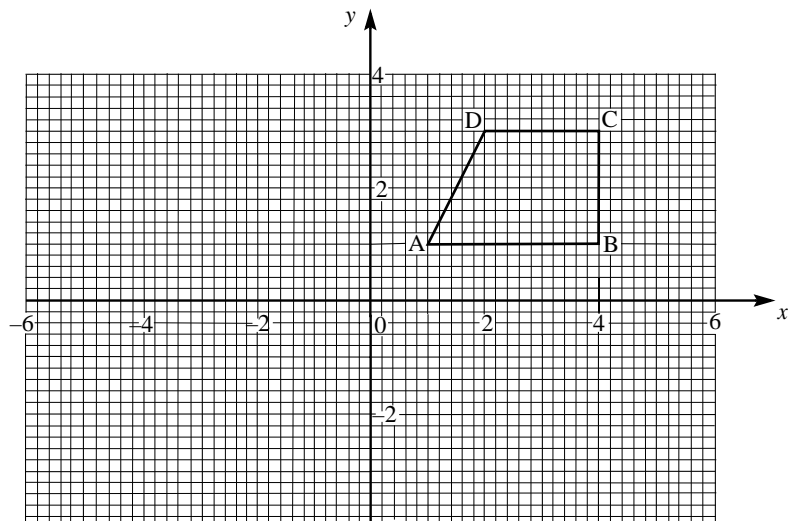

74. Reflections, Rotations and Translations 1

1) The diagram below shows the triangle A, B, C.

Copy this diagram and show the rotation

a) to A_1, B_1, C_1 of 90° clockwise about $(0,0)$

b) to A_2, B_2, C_2 of 90° anticlockwise about $(0,0)$

Also show the translation $\begin{pmatrix} -6 \\ -6 \end{pmatrix}$ to A_3, B_3, C_3 .

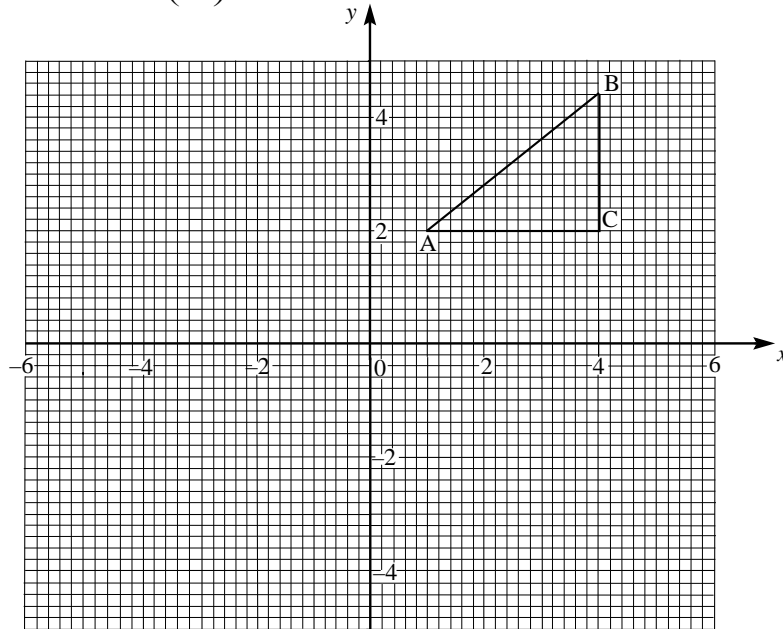

2) The diagram below shows the rectangle A, B, C, D.

Copy this diagram and show the rotation

a) to A', B', C', D' of 90° clockwise about $(-1,2)$

b) to A'', B'', C'', D'' of 180° about $(-1,2)$

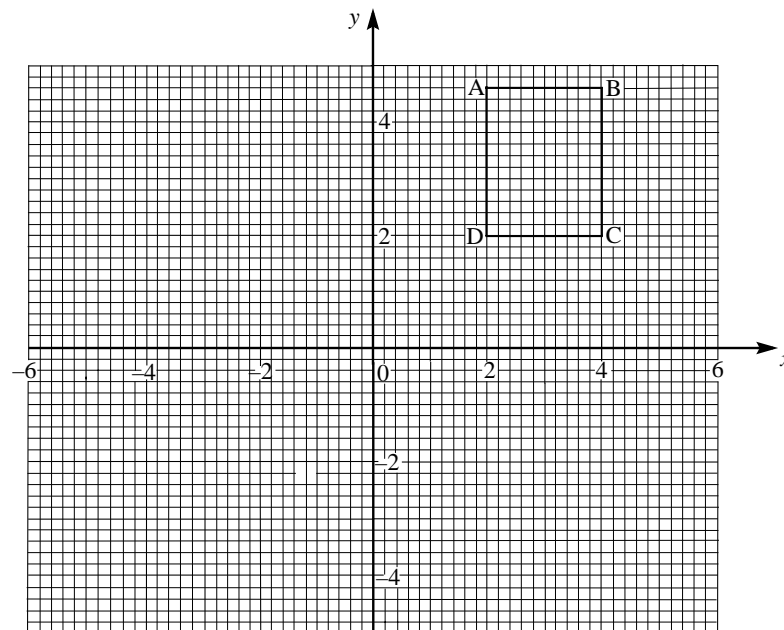

75. Reflections, Rotations and Translations 2

1) The diagram below shows the hexagon A, B, C, D, E, F.

Copy this diagram and show:

a) the rotation to A', B', C', D', E', F' of 90° clockwise about (0,0)

b) the translation $\begin{pmatrix} -2 \\ -3 \end{pmatrix}$ to A'', B'', C'', D'', E'', F'',

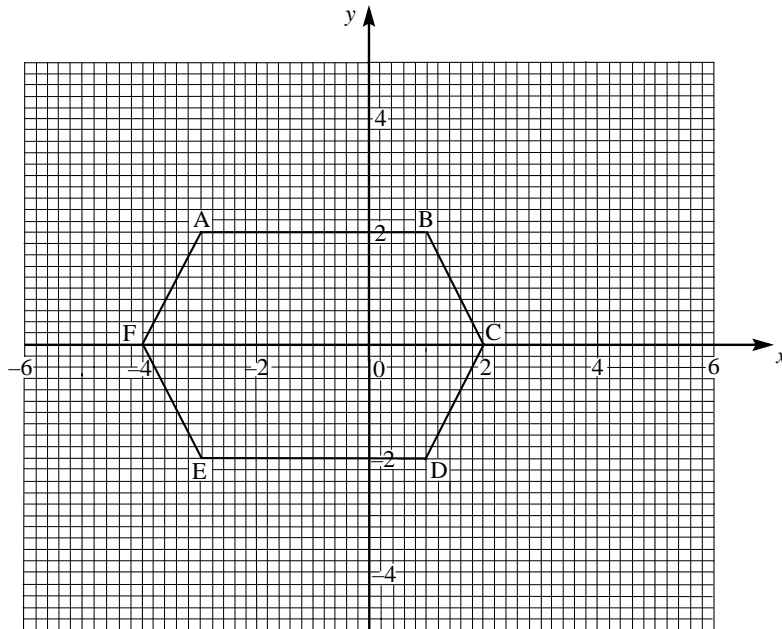

2) The diagram below shows the parallelogram A, B, C, D.

Copy this diagram and show

a) the rotation to A', B', C', D' of 90° clockwise about (0,0)

b) the translation $\begin{pmatrix} -4 \\ -4 \end{pmatrix}$ to A'', B'', C'', D''.

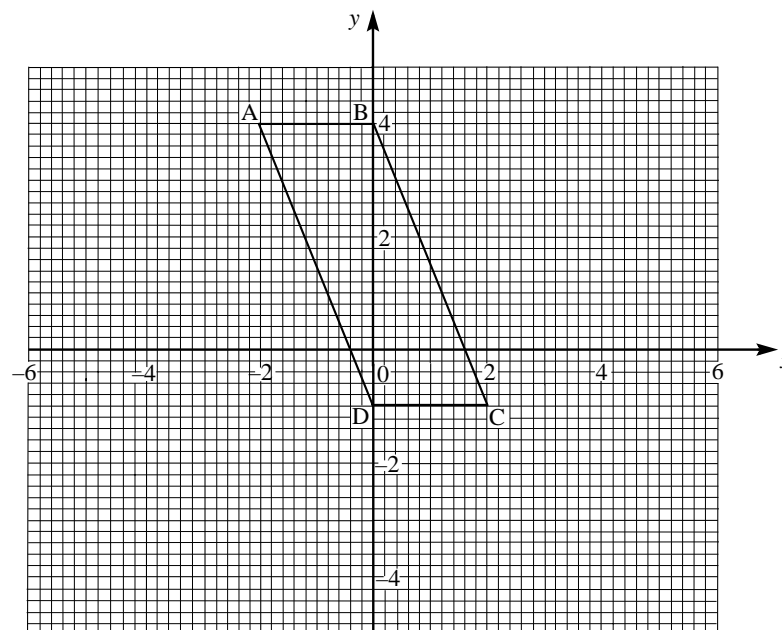

76. Enlargements Through a Point 1

The following shapes are enlarged through the points indicated. Draw in the enlargements.

1) $\times 2$

2) $\times 3$

3) Enlargement point $\times 4$

The diagram shows a grid with three sets of lines radiating from a point on the left. Each set includes a small shape and a larger empty space for the enlargement. Set 1: A right-angled triangle with vertices at (1, 2), (3, 2), and (3, 1) on a coordinate system where the origin is at the top-left. A larger empty space is provided for a $\times 2$ enlargement. Set 2: A quadrilateral with vertices at (1, 4), (3, 4), (4, 2), and (3, 1). A larger empty space is provided for a $\times 3$ enlargement. Set 3: A small irregular shape with vertices at (1, 6), (2, 6), (2, 5), and (1, 4). An arrow labeled 'Enlargement point' points to the origin (0, 0). A larger empty space is provided for a $\times 4$ enlargement.

77. Enlargements Through a Point 2

1) The diagram shows a square A, B, C, D.

Copy this diagram and enlarge it by a scale factor of 2 through the point (0,0)

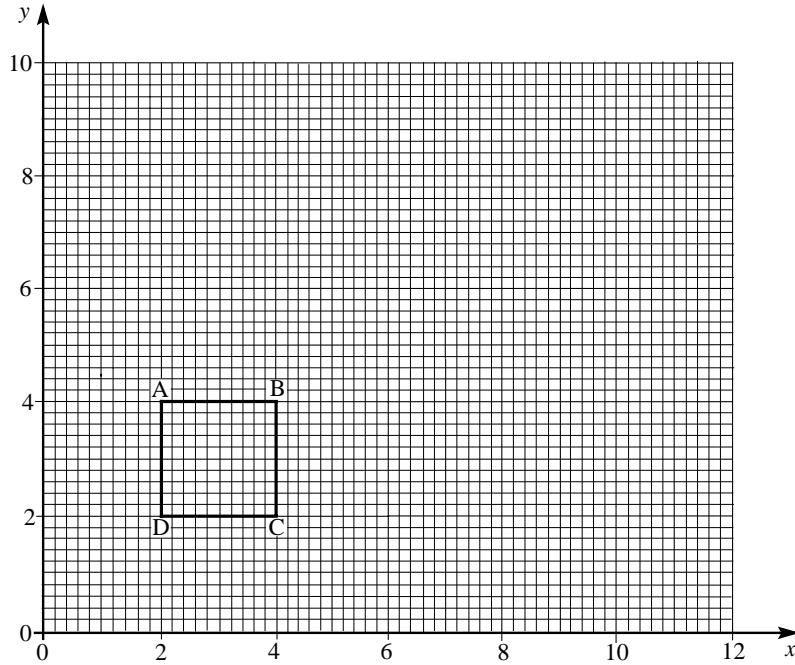

2) The diagram shows an octagon.

Copy this diagram and enlarge it by a scale factor of 3 through the point (0,0)

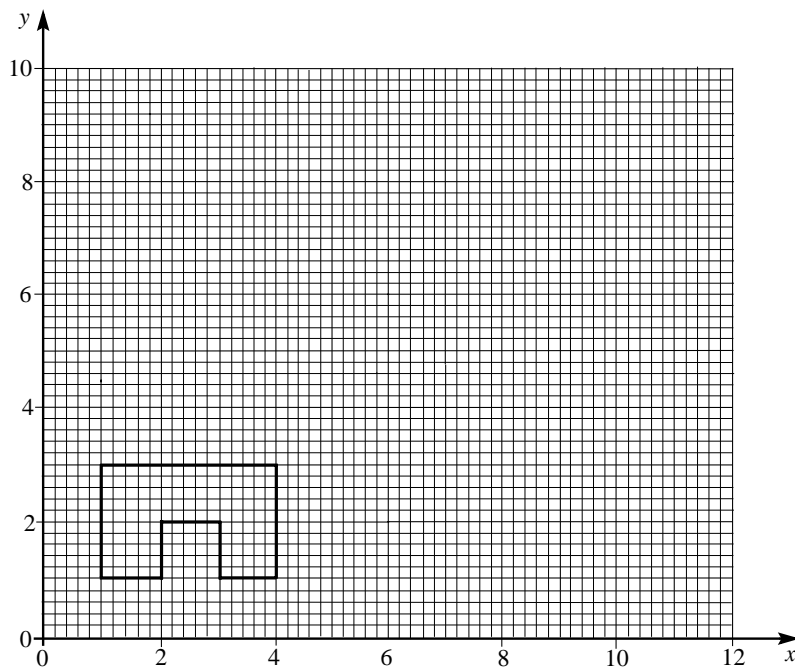

78. Enlargements Through a Point 3

1) The diagram shows a rectangle A, B, C, D.

Copy this diagram and enlarge it by a scale factor of 3 through the point $(-4, -4)$

One of the construction lines has already been put in.

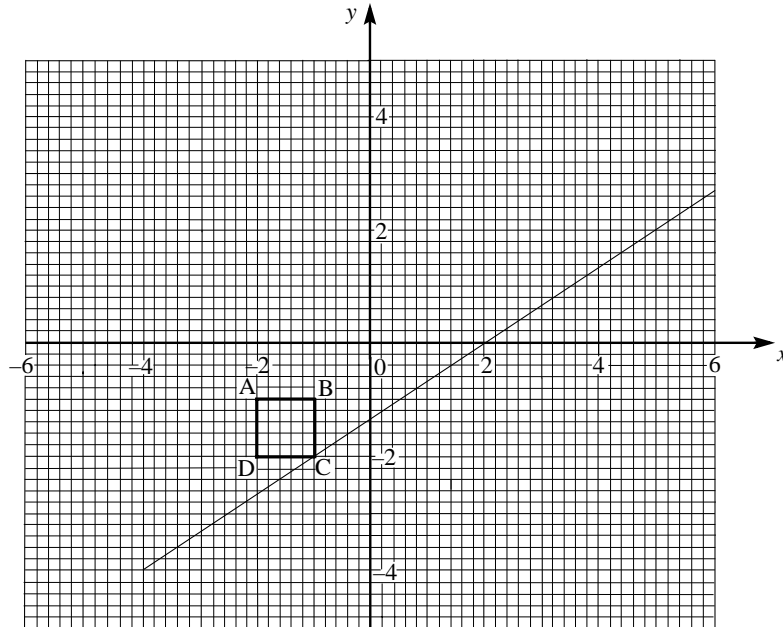

2) The diagram shows a triangle.

Copy this diagram and enlarge it by a scale factor of 2 through the point $(5,5)$

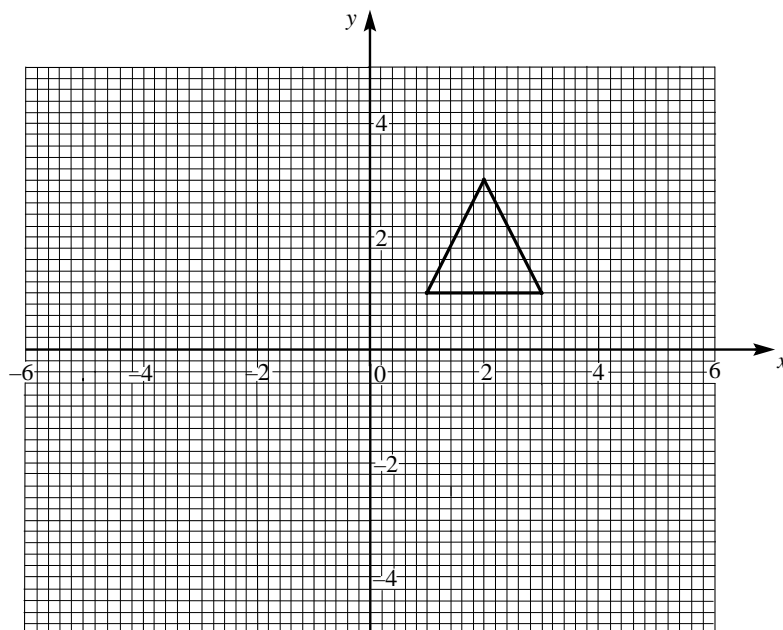

79. Planes of Symmetry

- 1) The diagram shows a plane cut through a cuboid. Is it a plane of symmetry?
How many planes of symmetry has a cuboid got?

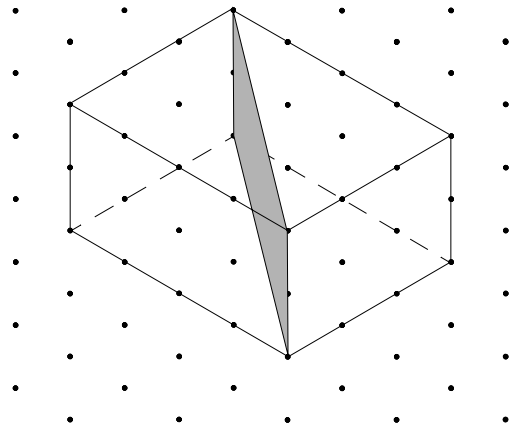

- 2) How many planes of symmetry has a cube got?

- 3) How many planes of symmetry have these shapes got?

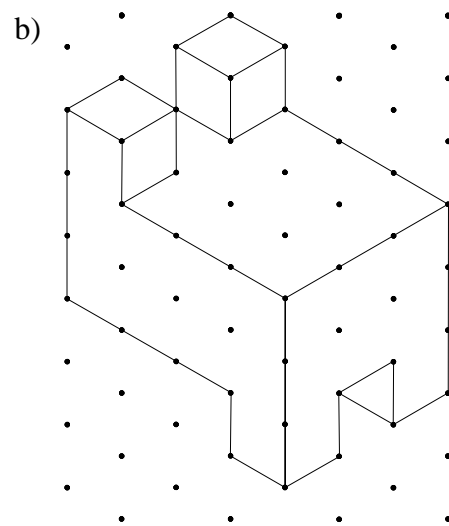
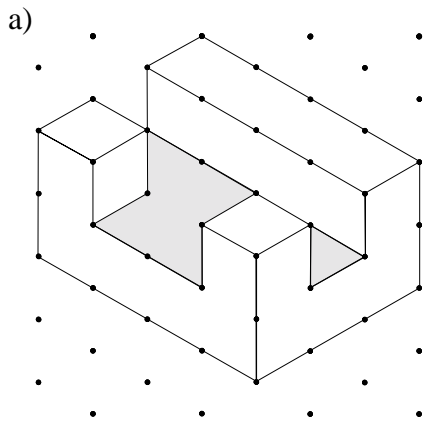

- 4) Which of the following diagrams represent planes of symmetry of the two shapes in question 3?

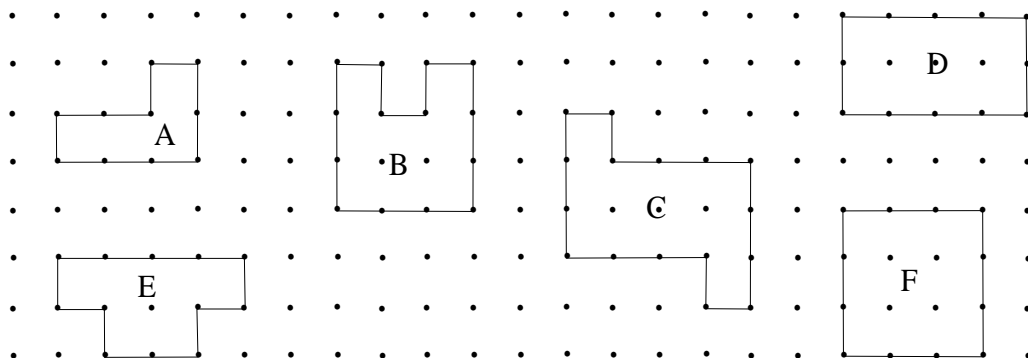

80. Similar Shapes

1) Squares are examples of similar shapes.

The length of square b is twice that of square a.

- a) What is the scale factor of square b to square a?
- b) How many smaller squares will fit into square b?

The length of square c is three times that of square a.

- c) What is the scale factor of square c to square a?
- d) How many smaller 'a' squares will fit into square c?

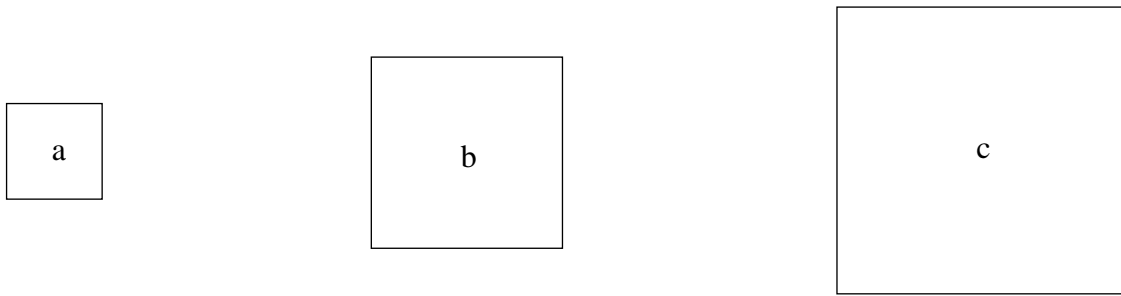

2) The two triangles below, ABC and XYZ are similar.

- a) Which angle is equal to angle ABC?
- The scale factor of triangle XYZ to ABC is 2.
- b) What is the length of side XY?
- c) If the length of side XZ is 7cm, what is the length of side AC?
- d) How many of the smaller triangles will fit inside the larger one (note: the answer is not 2).

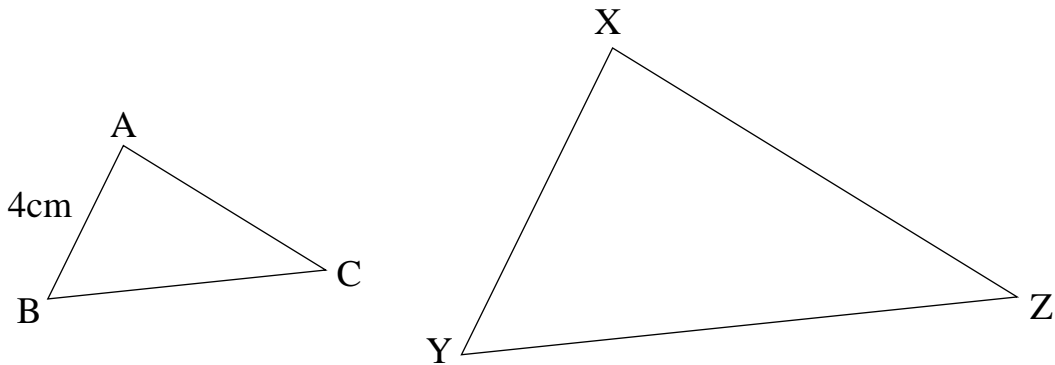

3) In the diagram, AC is parallel to XY.

- a) Which angle is equal to angle BAC?
- b) Which angle is equal to angle XYB?
- c) Complete this:
Triangle ABC is similar to triangle ...
- d) If AB is 8cm, what is the length of XB?
- e) What is the length of AX?

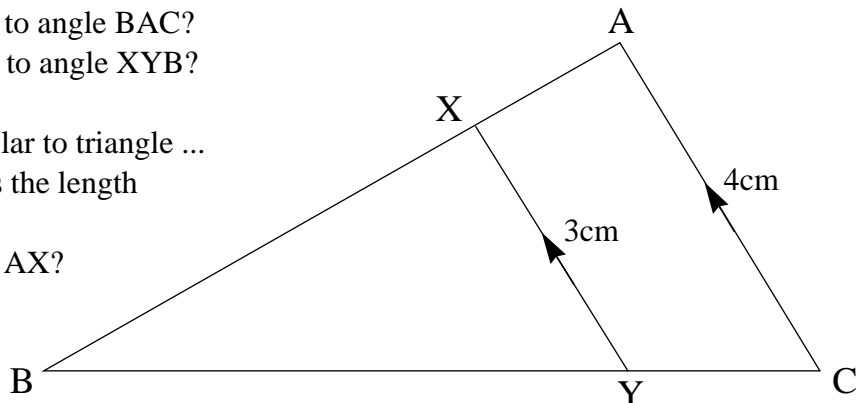

81. Locus Problems 1

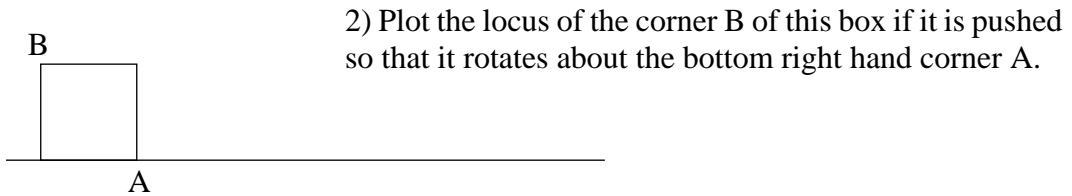
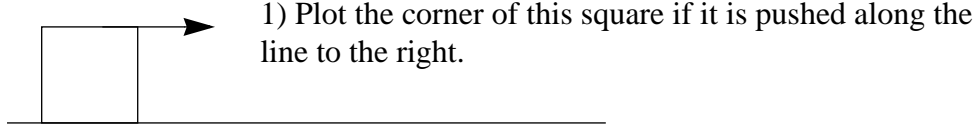

- 3) Plot the locus of the corner B of this box.
 First it is pushed from B to B₁, then rotated about the bottom right hand corner to B₂.
 Next it is pushed to B₃ and finally rotated about the bottom right hand corner to finish at B₄.

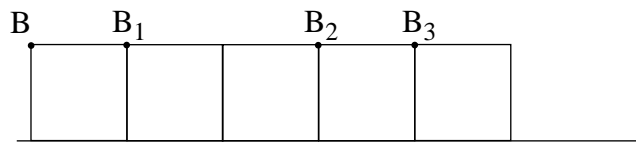

- 4) Draw a line AB about 12cm long. The ends of the line are labelled A and B.
 A fly stands above the line, about 4cm away from it and the same distance from A and B.
 The fly now walks toward the line, always keeping the same distance from A and B.
 The fly keeps walking until it is 4cm below the line.
 Plot the path of the fly.

- 5) a) A circle rotates around the inside of an angle without slipping. Plot the locus of the centre of the circle.

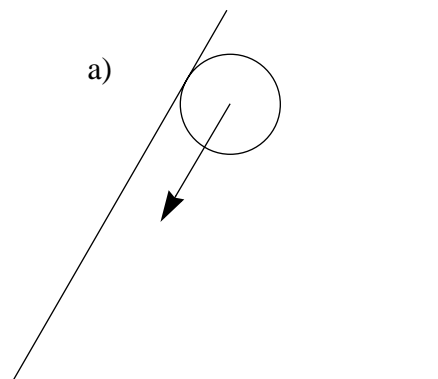

- b) Plot the locus of the centre of the circle if it rotates around the outside of the angle.

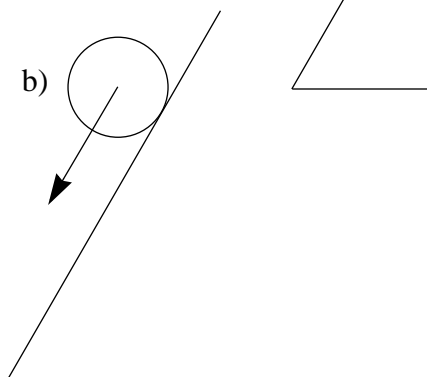

82. Locus Problems 2

- 1) A house has external dimensions of 16 metres by 10 metres. It has security lights on each corner with detectors which can recognise movement up to a distance of 8 metres. Using a scale of 1cm to represent 4 metres, shade in the area in which it will detect movement.

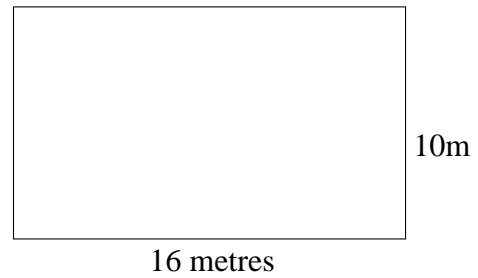

- 2) The entrance to a yachting marina is through a gap in the breakwater. The breakwater is 10 metres wide and the gap is 20 metres. Yachts cannot go within 6 metres of the breakwater. Using a scale of 1cm to represent 2 metres, shade in the area around the breakwater within which yachts are not allowed.



- 3) A field is watered through a nozzle which moves along a fixed rail 40 metres long. Water can reach up to a distance of 10 metres from the nozzle. Using a scale of 1cm to represent 4 metres, draw a diagram to show the area which can be covered by the water.

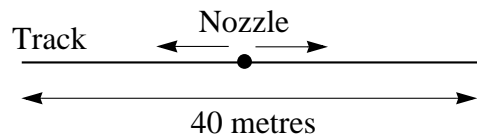

- 4) The diagram shows the plan of a house and garden. A tree is to be planted which must be at least 10 metres from the house and 5 metres from each of the fences. It also has to be at least 6 metres from the apple tree, located in the corner of the garden, 4 metres from each of the two fences. Using a scale of 1cm to represent 10 metres, copy this diagram and shade in the area in which the tree can be planted.

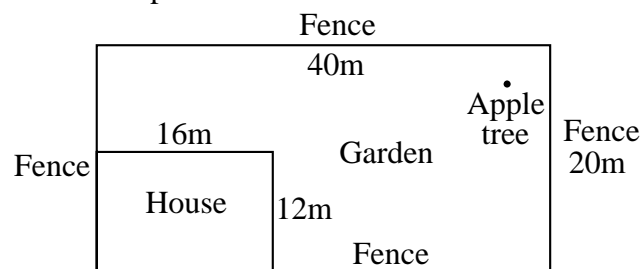

- 5) An aeroplane's course is determined by three radar stations, A, B and C. C is 15km north of B and A is 12km west of B. An aeroplane must always be the same distance from A and B until it is 10km from C when it turns due west. By construction, show the course of the aeroplane with respect to the three stations. Use a scale of 1cm to represent 2km. How far from B is the aeroplane when it alters course?

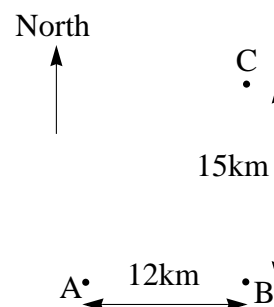

83. Constructions

Using ruler and compass only, construct each of the following. Do not use a protractor.

- a) an angle of 60°
- b) an angle of 90°
- c) an angle of 30°
- d) an angle of 45°
- e) an angle of 20°
- f)

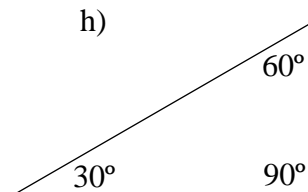
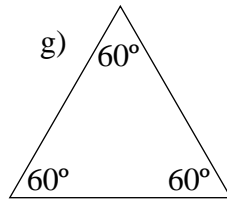
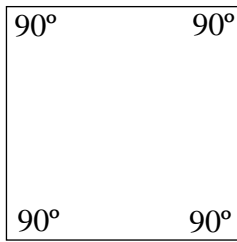

j) This shape is made up from three equilateral triangles

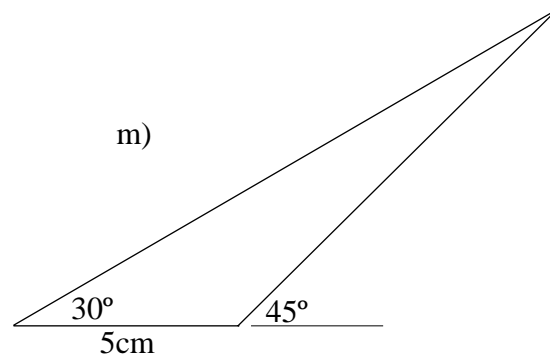
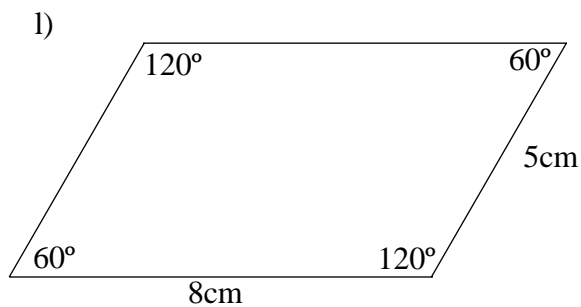
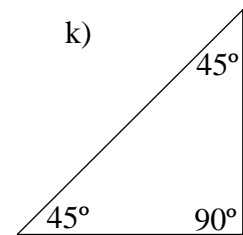
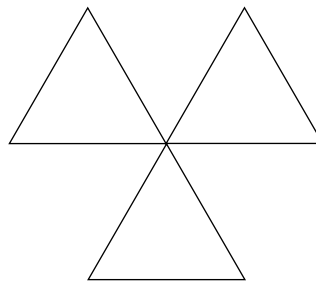
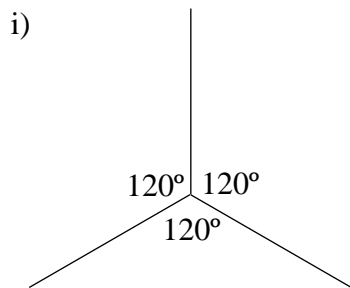

n) This shape can be drawn by using a compass and a ruler. Set your compass to a radius of 4cm and draw it accurately.

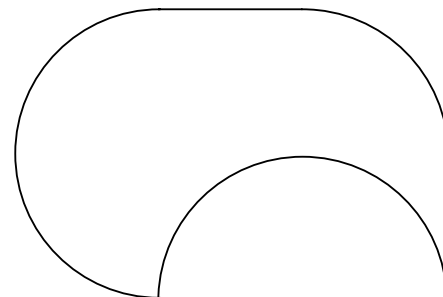

84. Scale Drawings

- 1) Draw this triangle accurately.
What is the length of AB?

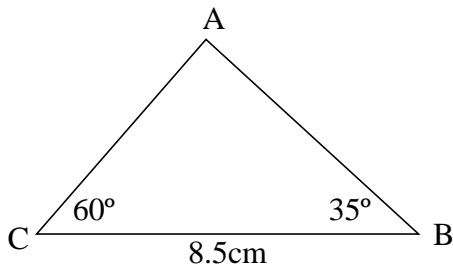

- 2) Draw this quadrilateral accurately.
What is the length of AB?

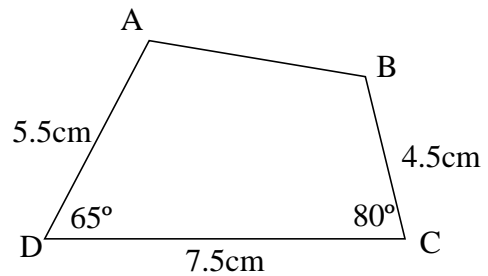

- 3) The following diagram shows a sketch of a field. Draw a scale drawing of the field using a scale of 1 cm to represent 10 metres. What is the approximate length of the side AB to the nearest metre?

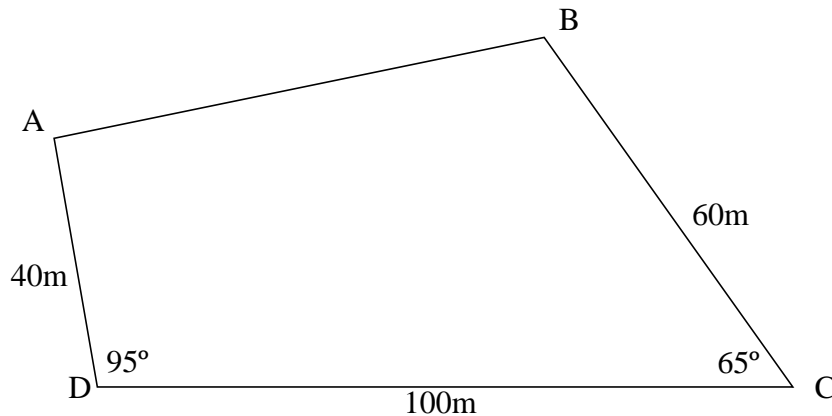

- 4) The diagram shows a sketch of a garden.
At one end is a house. Two fences are at right angles to the house.
Using a scale of 1 cm to represent 2 metres, draw an accurate plan of the garden.
What is the length of the fence DE?

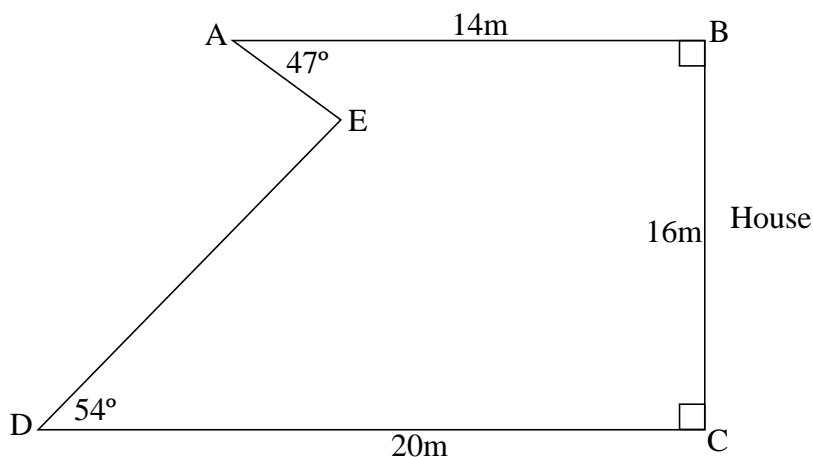

- 5) Draw accurately a rectangle measuring 9cm by 6cm.
6) Draw accurately a parallelogram measuring 9cm by 6cm with one internal angle of 60° .
7) Make a scale drawing of an equilateral triangle with sides of 1 metre. Use a scale of 1mm to represent 1cm

85. Plans

1) The diagram shows the plan of a kitchen. The scale of the plan is 1:50.

- a) What does 1cm on the diagram represent?
- b) Measure the length and width of the diagram. Write them down.
- c) What is the actual length and width of the room?
- d) What is the actual width and length of the table?

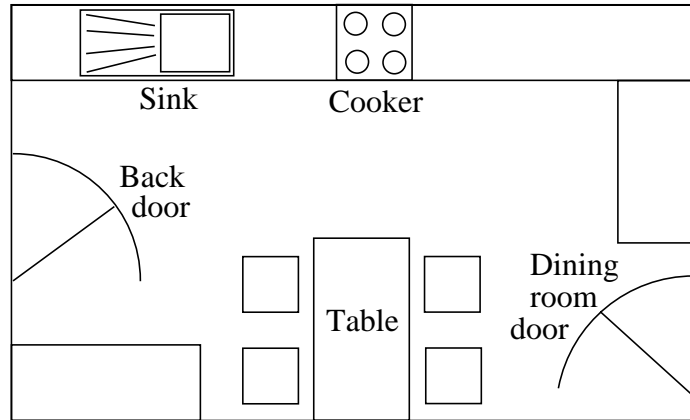

2) Plans of a garage are made to the scale of 1:20.

Copy and complete the table below.

	Garage	Plan
Length	8 metres	
Width		20cm
Height	2.5m	
Number of windows		2

3) The diagram shows a lamp. Its actual height is 30cm

- a) Measure its height.
- b) What is the scale of the drawing?
- c) What is the actual height of the lamp shade?

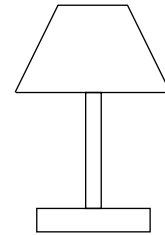

4) The diagram below shows a scale drawing of a paper clip. The actual clip is approximately 32.5mm long.

- a) Measure the length of the diagram and write down its scale in the form ? : 1.
- b) What is the width of the actual clip.

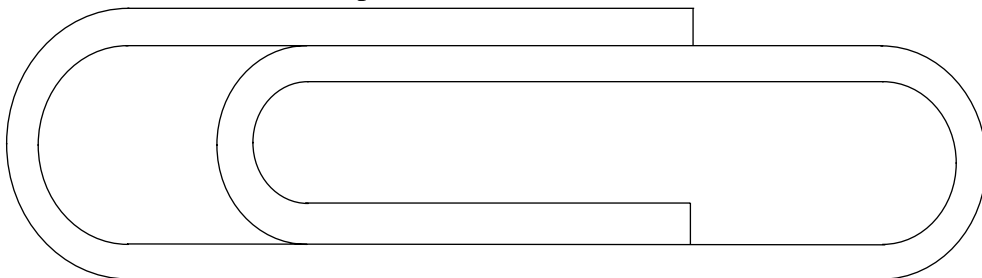

4) The diagram below shows a scale drawing of a paper clip. The actual clip is approximately 32.5mm long.

- a) Measure the length of the diagram and write down its scale in the form ? : 1.
- b) What is the width of the actual clip?

5) An engineer makes a scale drawing of a computer chip. The scale is 5:1 (i.e the drawing is bigger than the chip)

- a) If its length is 6cm, what is its length on the drawing?
- b) Its width on the drawing is 10cm. What is its actual width?
- c) Its thickness is 2mm. What is this on the drawing?
- d) If it has 4 sides on the drawing, how many sides does it actually have?

86. Plans and Elevations 1

The diagram below shows a cuboid with a smaller cuboid cut from it. In the grid below it three views have been started, two elevations in directions S(side) and F(front), and a plan P. Finish off these three elevations.

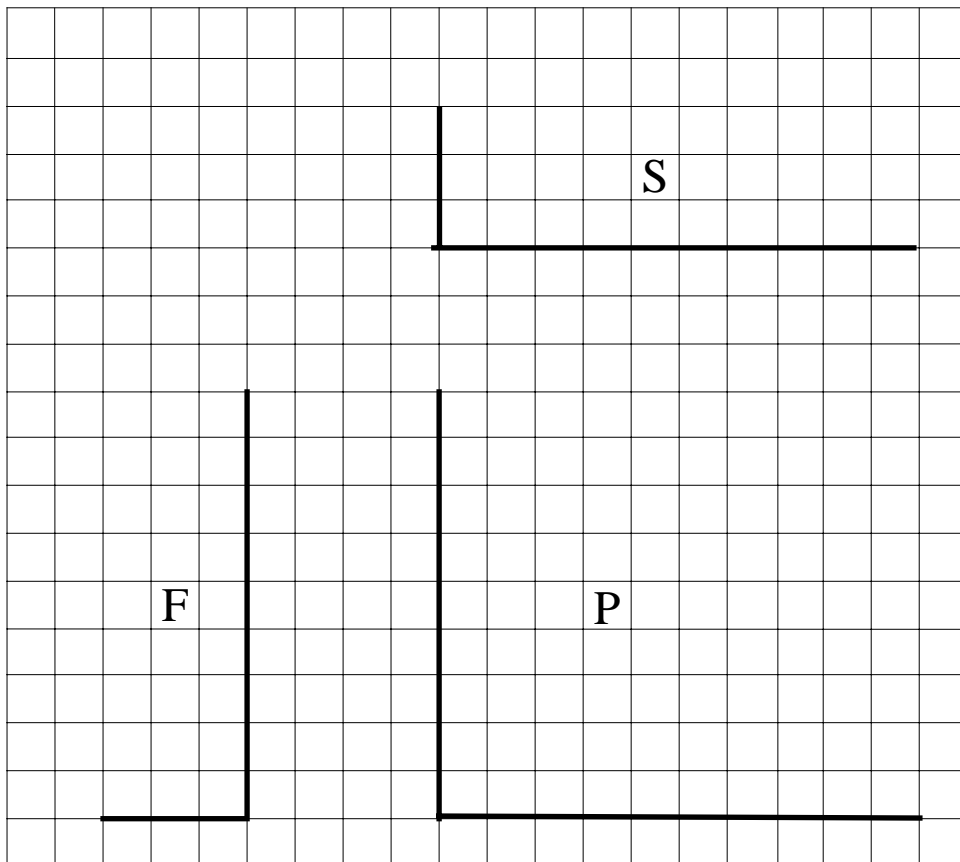
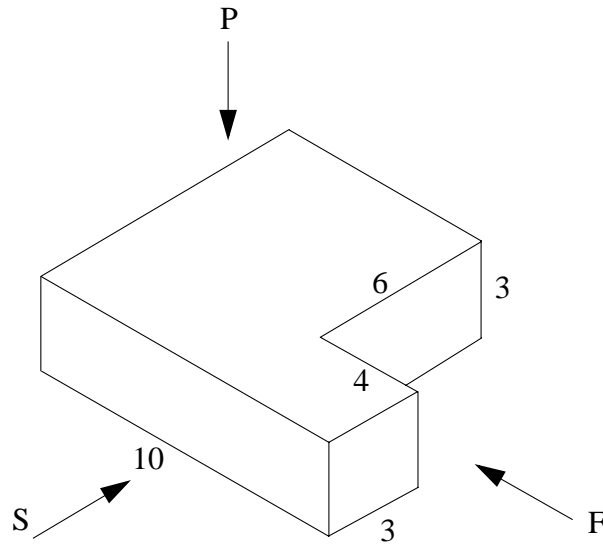

87. Plans and Elevations 2

The diagram below shows a cuboid with a smaller cuboid on top of it. In the grid below it three views have been started, two elevations in directions S(side) and F(front), and a plan P. Finish off these three elevations.

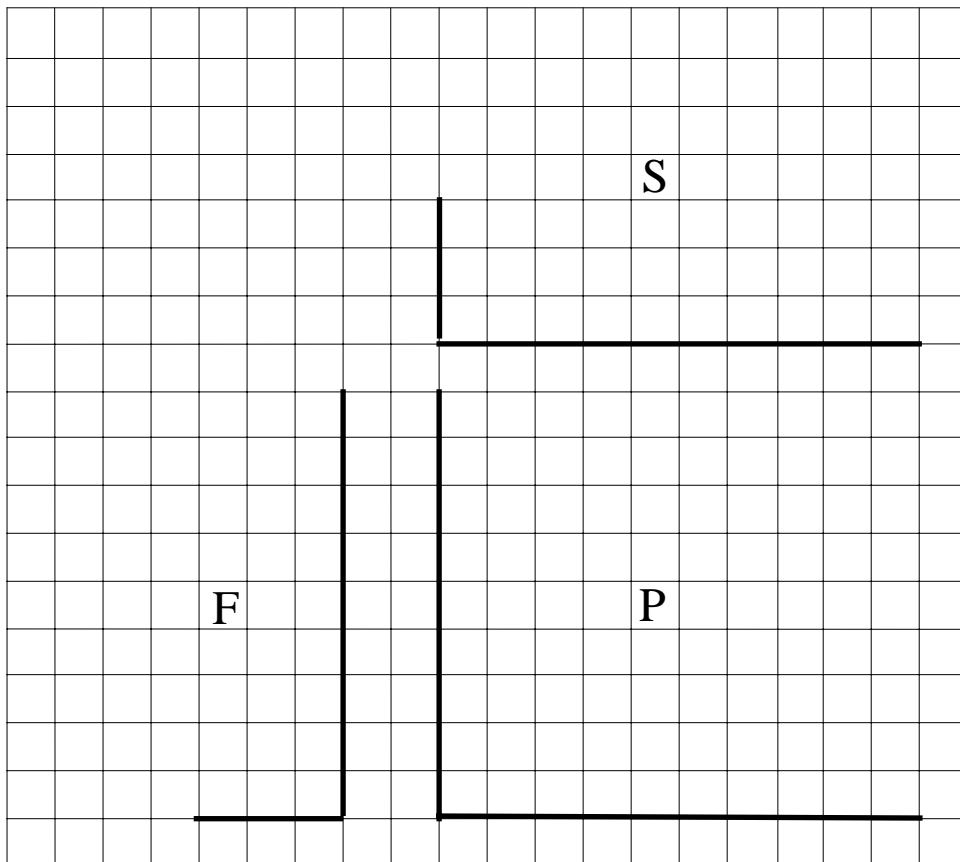
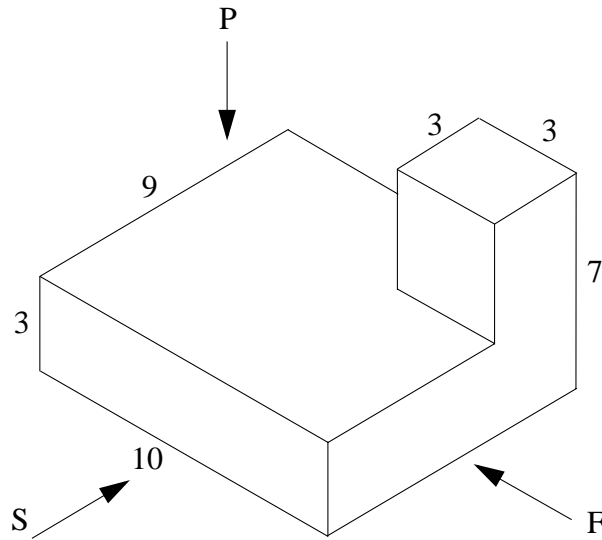

88. Plans and Elevations 3

Below are shown two cuboids with parts cut away. Draw diagrams of each shape when viewed from the directions A, B and C. All the dimensions are in centimetres.

1)

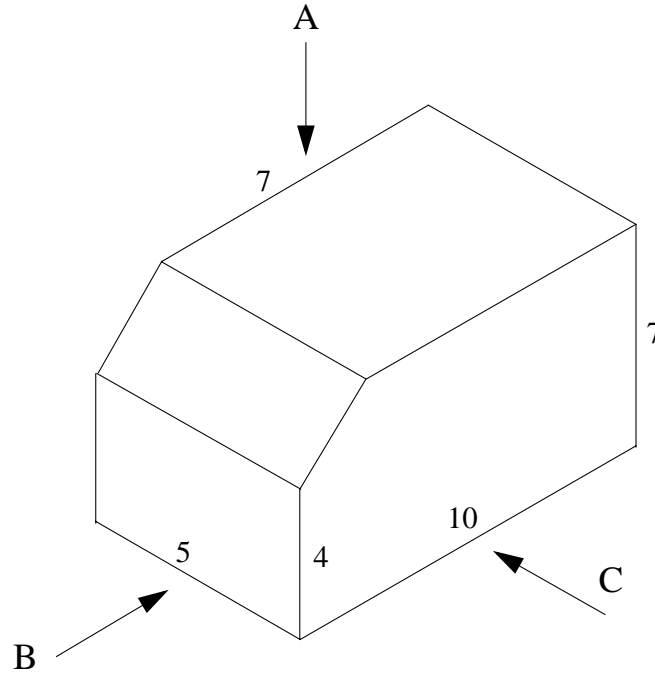

2)

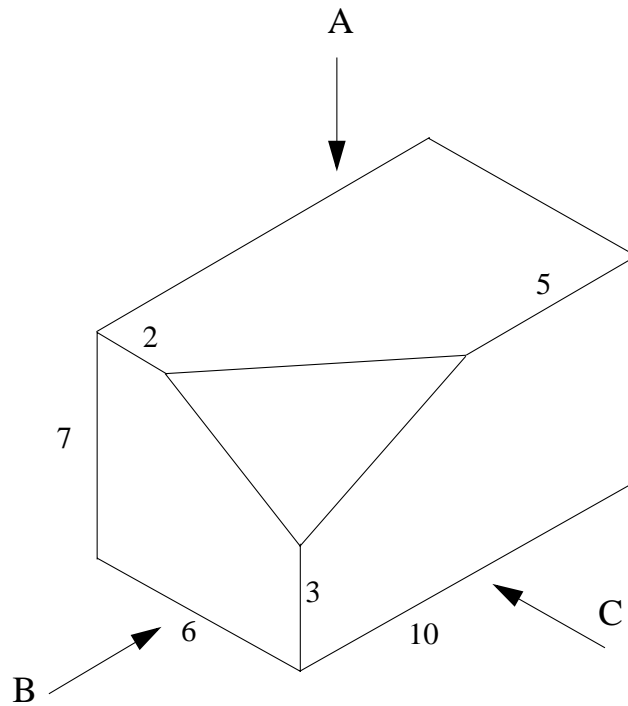

89. Plans and Elevations 4

Below are shown two engineering components. Draw diagrams of each shape when viewed from the directions A, B and C.

1)

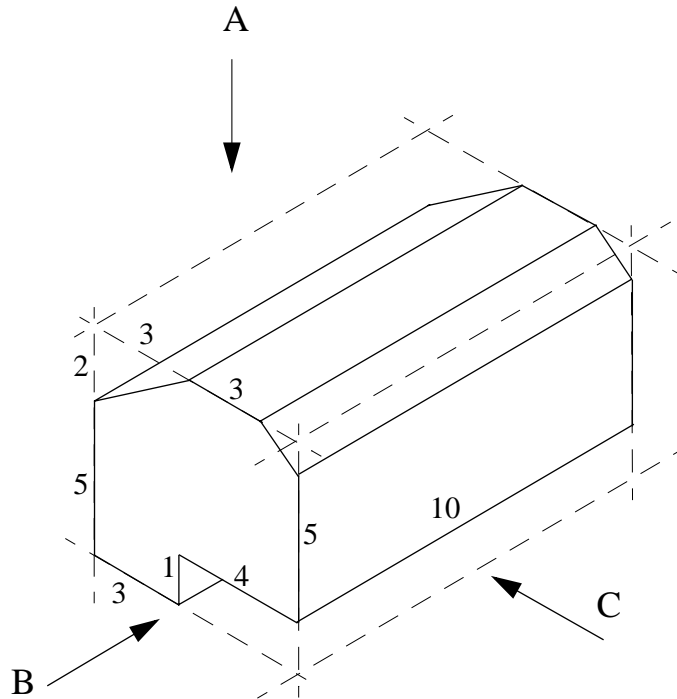

2)

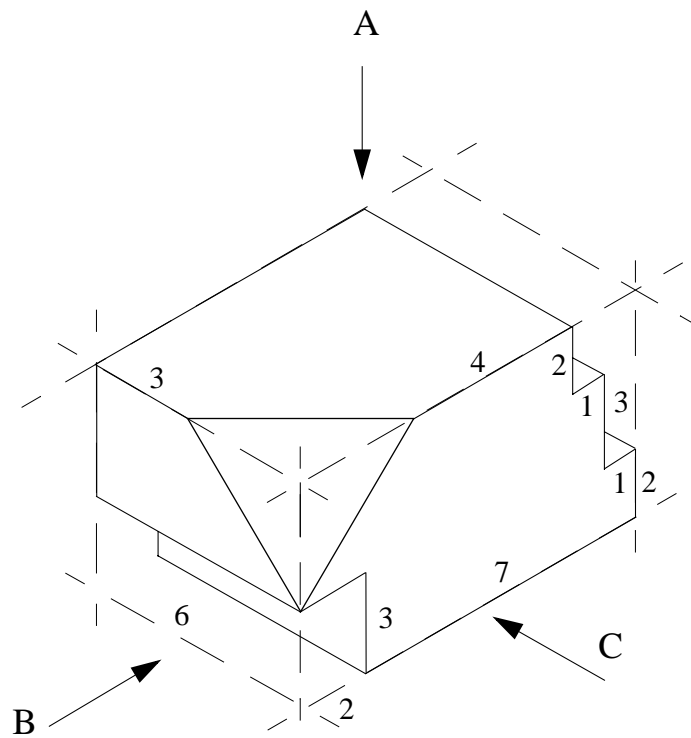

90. Using Measurements

- 1) What is the length of this pencil a) in millimetres, b) in centimetres and millimetres, c) in decimal centimetres?

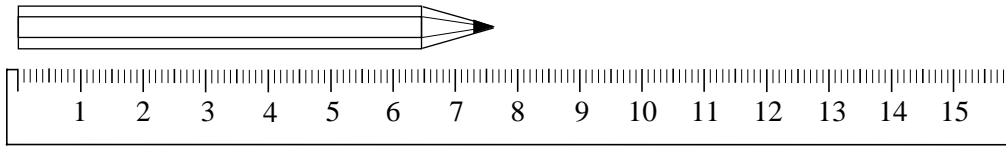

- 2) What is the length of this pencil a) in millimetres, b) in centimetres and millimetres, c) in decimal centimetres?

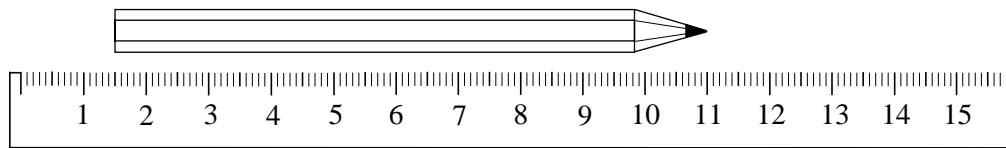

- 3) What are the approximate lengths, in inches, of the pencils in questions 1 and 2?
 4) a) How much liquid is in this jug (i) in millilitres, (ii) as a decimal of a litre?
 b) Is this more or less than 1 pint?

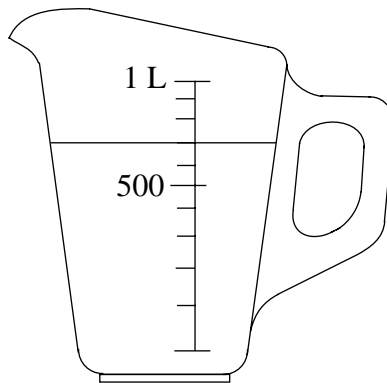

- 5) Colin and his dad weighed themselves on the bathroom scales. These were the results.

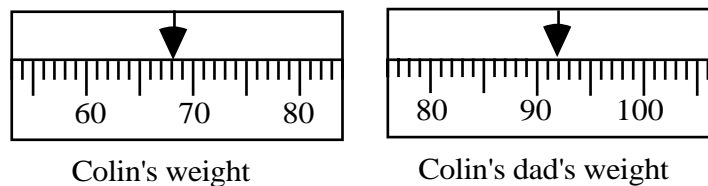

- a) Which unit of measure is used? b) What was Colins weight? c) What was Colin's dad's weight? d) What was their difference in weight? e) Approximately how many pounds does each of them weigh? f) If there are 14 pounds in one stone, what is each of their approximate weights in stones and pounds?
 6) The distance from Sarah's home to the centre of London is 56 miles. What is the approximate distance in kilometres?
 7) William's height is 176 centimetres. What is his approximate height in feet and inches?
 8) A water tank contains 100 litres of water. What is it's approximate capacity in gallons?
 9) David buys 3 pints of milk and 2kg of carrots from the local shop. Meanwhile his mum buys 2 litres of milk and 4 pounds of carrots from the supermarket. Who buys the most of each item? Show all your workings out.

91. Degree of Accuracy

Exercise 1.

- 1) Round off each of the following numbers to the accuracy stated.

a) 354 to the nearest hundred.	b) 1432 to the nearest hundred.
c) 184 to the nearest ten.	d) 1593 to the nearest hundred.
e) 3136 to the nearest hundred.	f) 35,428 to the nearest thousand.
g) 14,640 to the nearest thousand.	h) 23,457 to the nearest thousand.
- 2) Round off the number 37,583.

a) to the nearest ten.	b) to the nearest hundred.
c) to the nearest thousand.	d) to the nearest ten thousand.
- 3) Which of these numbers can be rounded off to 1500?

a) 1564	b) 1487	c) 1445	d) 1506
e) 1547	f) 1450	g) 1550	h) 1451
- 4) State the limits between which the following whole numbers lie. Each has been rounded off in the way shown in the brackets.

a) 230 (to the nearest 10)	b) 4400 (to the nearest 100)
c) 38,000 (to the nearest 1000)	d) 1840 (to the nearest 10)
e) 40,000 (to the nearest 10,000)	f) 11,000 (to the nearest 100)
g) 2300 (to the nearest 100)	h) 760 (to the nearest 10)
i) 34,300 (to the nearest 100)	j) 140,000 (to the nearest 10,000)

Exercise 2.

Copy these diagrams into your book and fill in the blanks with either a number, < or ≤.

1)

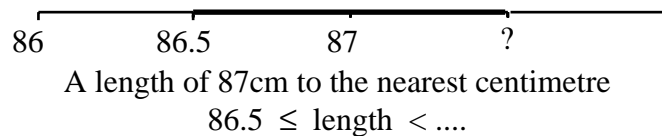

2)

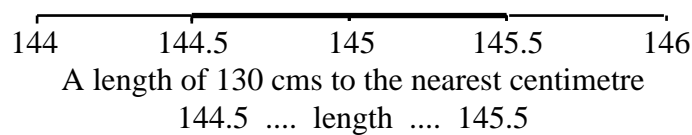

3)

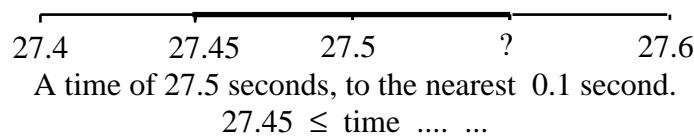

4)

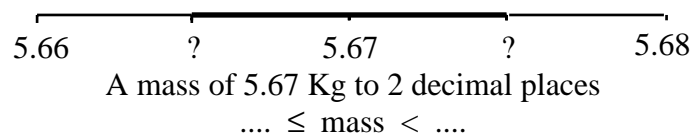

5)

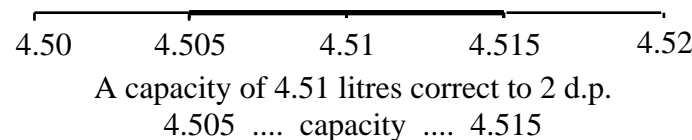

92. Bearings

Exercise 1

Draw diagrams to show the following bearings.

- 1) A is N 40° E (040°) from B
- 2) C is N 35° W (325°) from D
- 3) G is S 27° E (153°) from H
- 4) J is S 52° W (232°) from K
- 5) L is N 43°W (317°) from M
- 6) P is S 28° W (208°) from Q

Exercise 2

By measuring the angles, write down the bearing of point P from point A in each case.

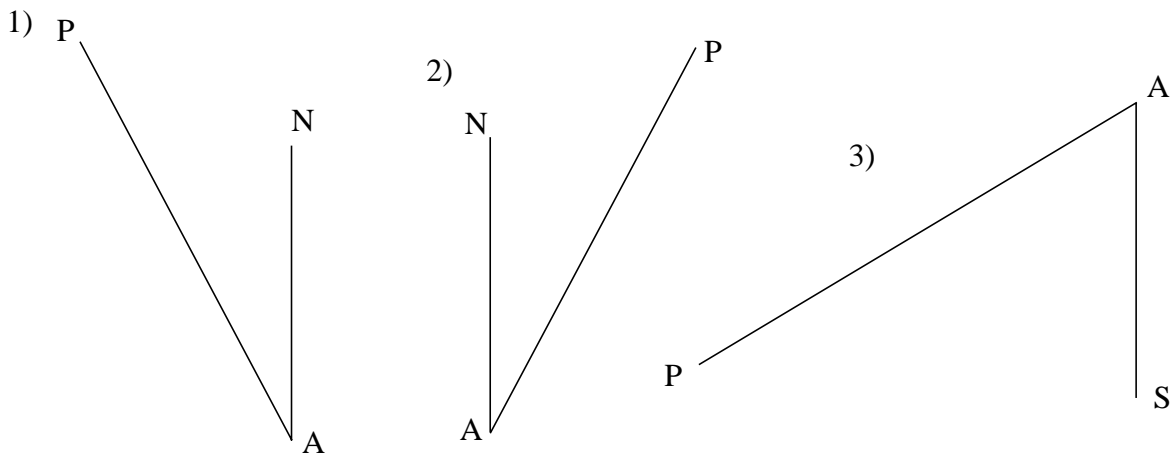

Exercise 3

- 1) The picture shows a diagram of four towns, A, B, C and D. By measuring, what is the bearing and distance of a) A from B, b) C from D, c) D from A.

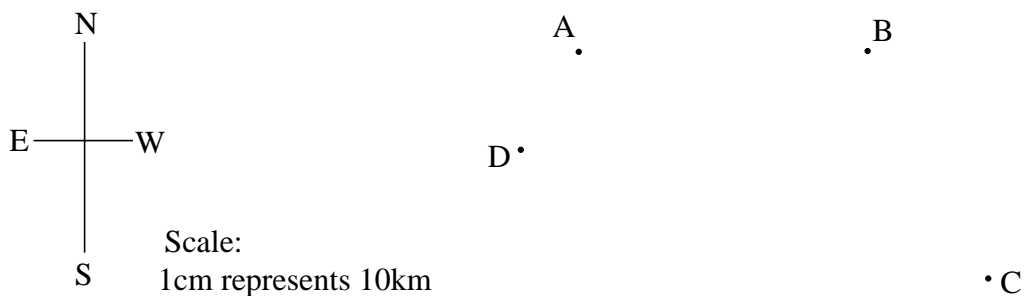

- 2) A ship sails from a port P on a bearing of N 35° E (035°) for 6km until it reaches point X. It then changes course onto a bearing of S 48° E (132°) for a distance of 8km until it reaches point Y. Draw the ship's path accurately using a scale of 1cm to 1km. What is the bearing and distance of point Y from the port P?
- 3) An aeroplane flies from airport A on a bearing of S 22° W (202°) for 75km until it reaches point B. It then changes course onto a bearing of S 42°W (222°) for a distance of 80km until it reaches point C. Draw the aircraft's path accurately using a scale of 1cm to 10km. What is the bearing and distance of point C from the airport A?

93. Area and Perimeter 1

1) What is the area and perimeter of each of these shapes?

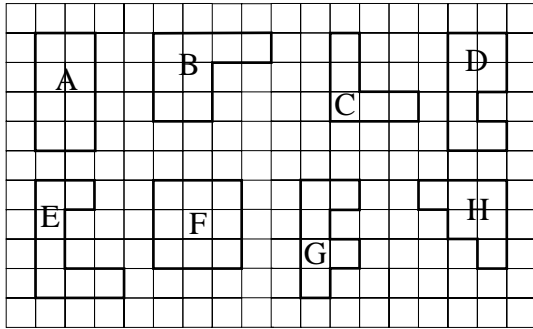

2) Which of these shapes has the larger area?

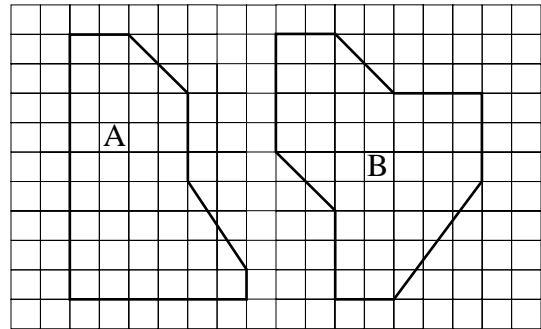

3) By counting squares, estimate the area of this shape.

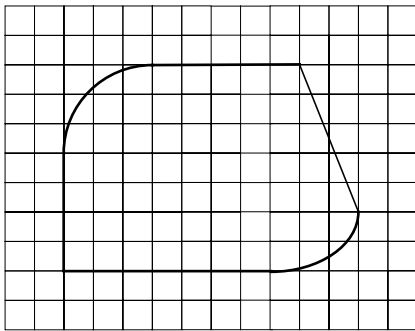

4) Calculate the perimeter and area of this shape

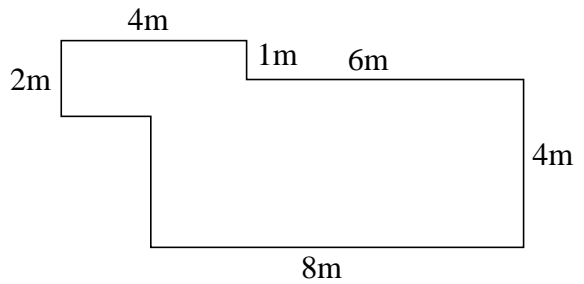

5) The diagram shows part of a conservatory floor. It is to be covered with square tiles measuring 20cm by 20cm.

- How many tiles are needed? It is to be surrounded with thin lengths of tile each 20cm long.
- What is the perimeter of the conservatory?
- How many lengths of tile will be needed?

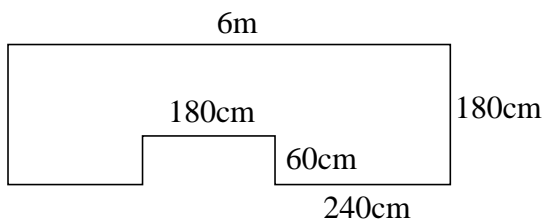

6) What is the area of each of these triangles?

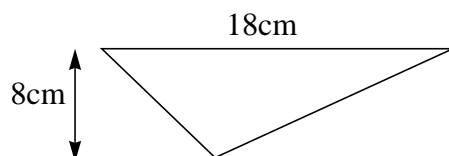
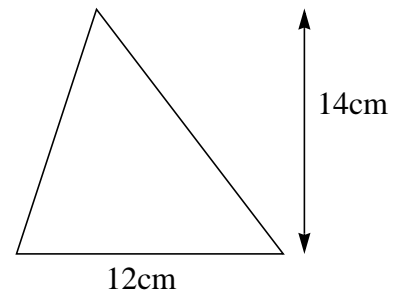
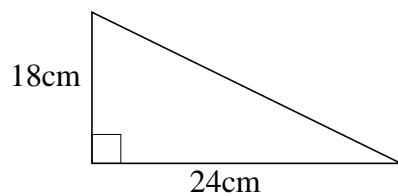

7) What is the area of a triangle with a base of 10cm and a height of 12cm

94. Area and Perimeter 2

1) Calculate the areas and perimeters of rectangles measuring;

- | | | |
|-----------------------------|----------------------------|------------------|
| a) 5cm by 4cm | b) 9cm by 9cm | c) 7cm by 2.5cm |
| d) 6cm by 2.8cm | e) 9.4 metres by 12 metres | f) 70cm by 19cm |
| g) 0.4 metres by 1.2 metres | h) 19cm by 0.45metres | i) 3.5m by 195cm |

2) Calculate the areas of these shapes;

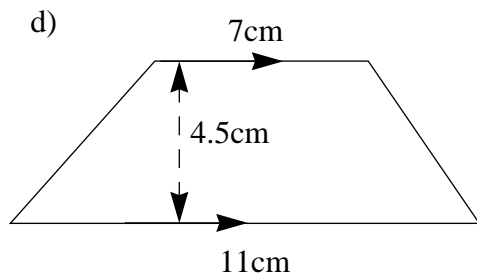
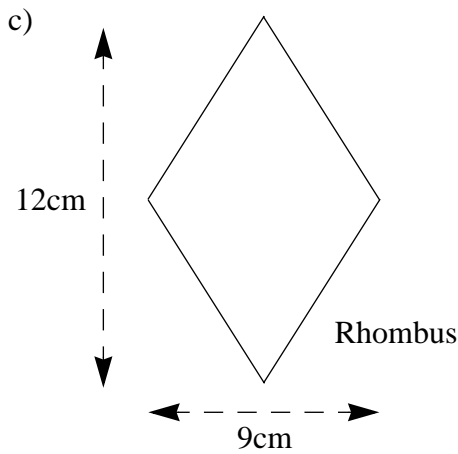
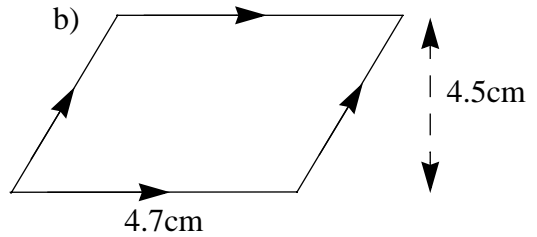
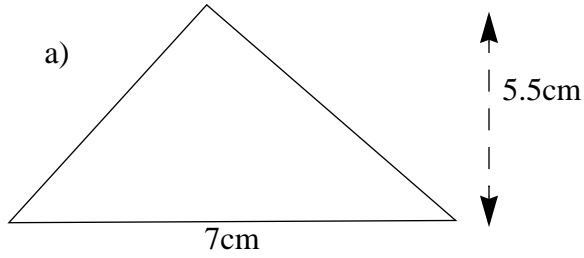

3) Calculate the areas and perimeters of these shapes. All dimensions are in centimetres.

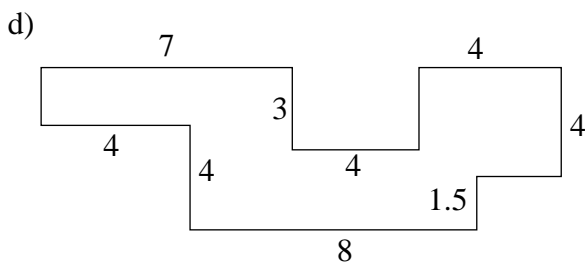
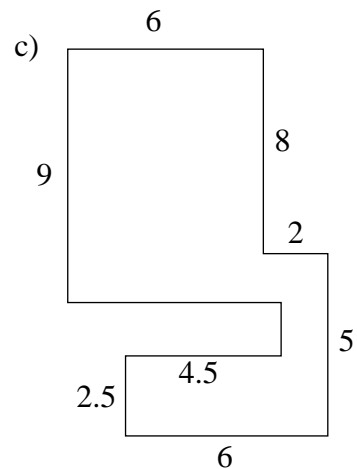
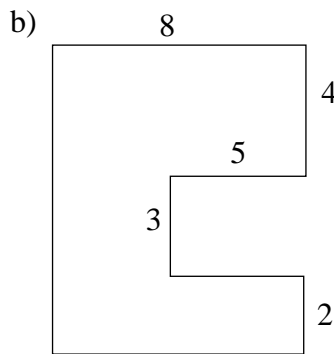
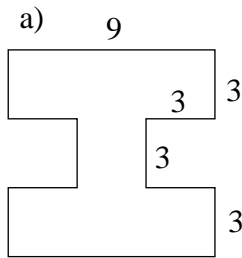

95. Circumference of a Circle

In each of the following questions use $\pi = 3.14$ or use the π button on your calculator.

Exercise 1

Calculate the circumference of each of the following circles

- | | | |
|---------------------|--------------------|---------------------|
| 1) Radius 3cm | 2) Radius 5cm | 3) Radius 12cm |
| 4) Radius 16 metres | 5) Radius 7 metres | 6) Radius 13 metres |
| 7) Diameter 10cm | 8) Diameter 22cm | 9) Diameter 34cm |
| 10) Diameter 1.8m | 11) Diameter 19m | 12) Diameter 35m |

Exercise 2

Calculate the diameters of circles with the following circumferences (correct to 4 significant figures);

- | | | |
|--------------|----------|---------------|
| 1) 30cm | 2) 85cm | 3) 1.7 metres |
| 4) 24 metres | 5) 154cm | 6) 235 metres |

Exercise 3

1)

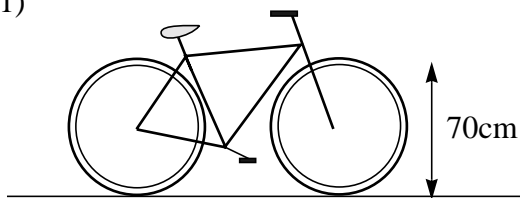

- A bicycle wheel has a diameter of 70cm.
- What is its circumference?
 - How far will the bicycle travel if the wheel turns 20 times?

2)

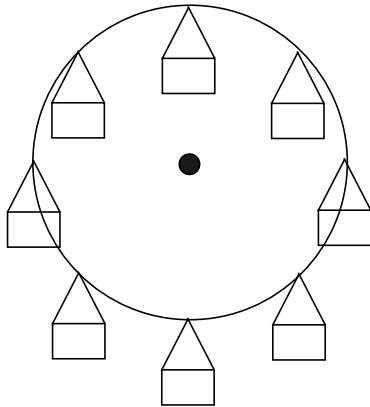

- The diagram shows a fairground wheel. Its diameter is 10 metres. Calculate
- the distance travelled by one of the chairs in one complete revolution.
 - the distance travelled by one chair when the wheel rotates 20 times.

3)



- A hose pipe is stored by winding it around a drum of diameter 50cm. If it makes 26 turns, how long is the hose correct to the nearest metre?

Hose

- A car wheel has a diameter of 60 cm. How far will the car travel if the wheel turns 20 times?
- If the same car wheel turns 1500 times, find the distance travelled correct to the nearest metre.
- A car has a wheel diameter of 57 cms. How many revolutions does it make while travelling a distance of 10 kilometre? (give your answer correct to the nearest whole number)
- A length of cotton measuring 10 metres is wound around a cotton reel of diameter 3.5cms. How many turns does it make? (correct to the nearest turn)

96. Areas of Circles

In each of the following questions use $\pi = 3.14$ or use the π button on your calculator.

1) Calculate the areas of the following circles.

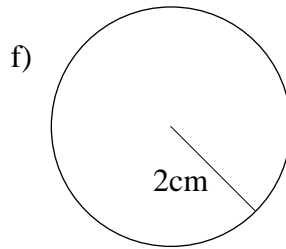
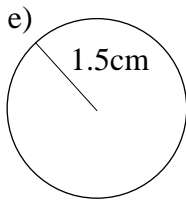
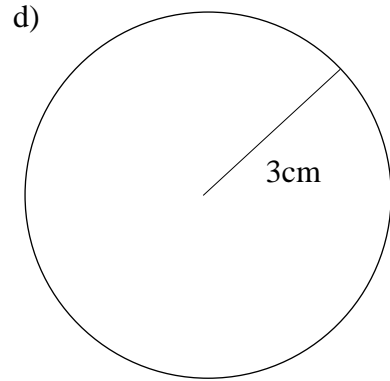
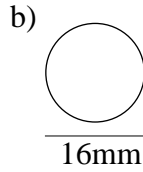
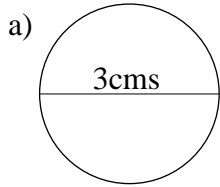

2) Calculate the areas of each of the following circles.

a) 10cm diameter

b) 6cm diameter

c) 5cm diameter

d) 12cm radius

e) 9cm radius

f) 7.5cm radius

g) 4.6cm diameter

h) 4.3cm radius

i) 8.4cm diameter

3) A compact disc has a diameter of 12cms and a hole in the centre of diameter 1.5cm.

Calculate

a) The area of the big circle.

b) The area of the hole in the middle.

c) The area of plastic making up the disc

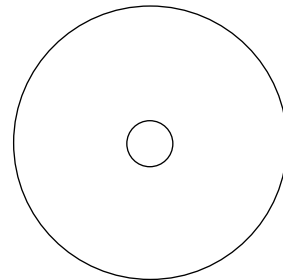

4) Which has the larger area, a circle of diameter 3cm or a square of side 2.5cm?

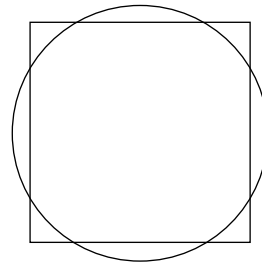

5) The diagram shows a circular garden with a path around it.

The diameter of the garden is 8 metres. The diameter of the garden and path is 10 metres. Calculate

a) The area of the garden

b) The area of the garden and path

c) The area of the path only

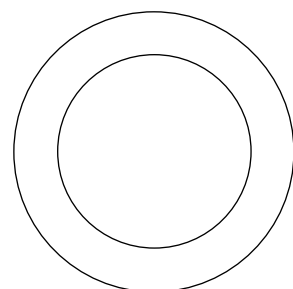

97. Volume 1

1) This cube measures 3cm by 3cm by 3cm. What is its volume?

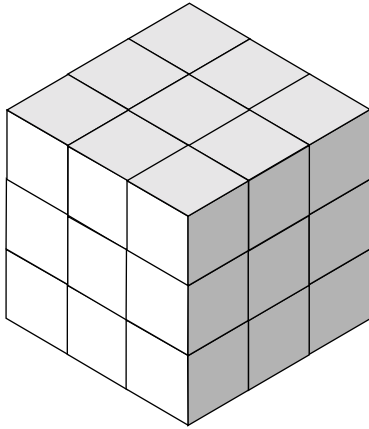

2) What is the volume of this shape?

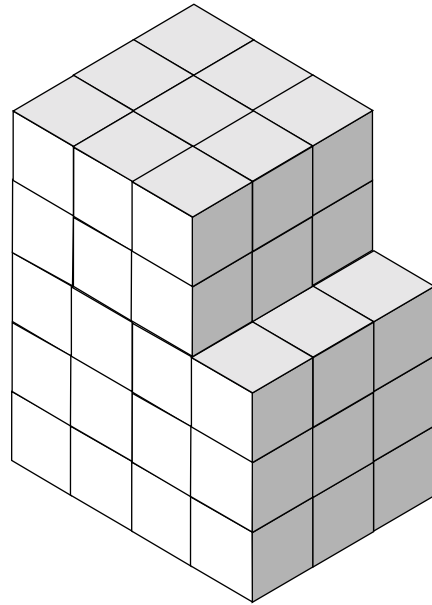

3) What is the volume of this shape?

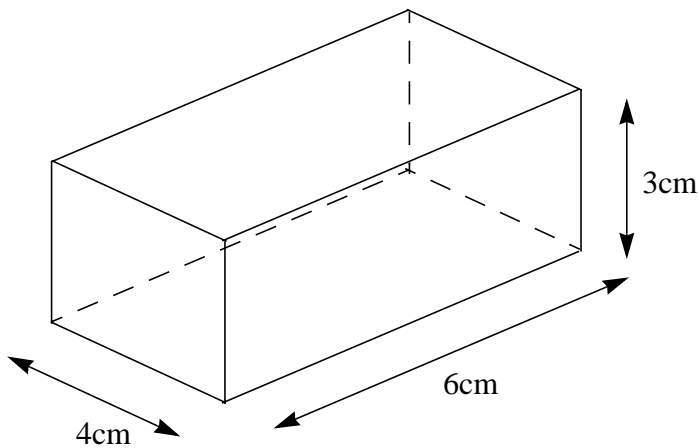

4) What is the volume of a cuboid measuring 2cm by 3cm by 5cm?

5) A box measures 8cm by 6cm by 4cm. How many 2cm cubes will fit inside it?

6) A cuboid measures 6cm by 6cm by 4cm. Sketch another cuboid with the same volume.

7) The container on the left measures 4cm by 4cm by 12cm. It is completely filled with water.

The base of the second container measures 8cm by 6cm.

Water from the first container is poured into the second one.

How far up the sides of the second container will the water rise?

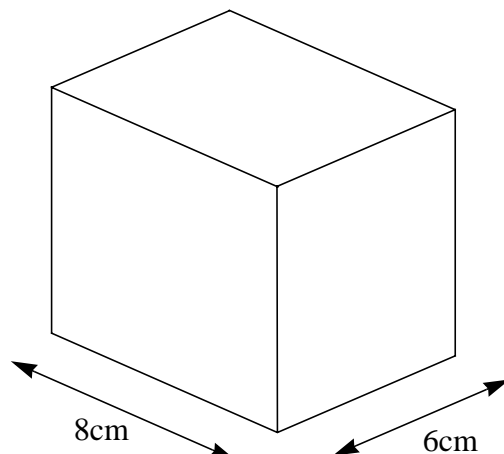
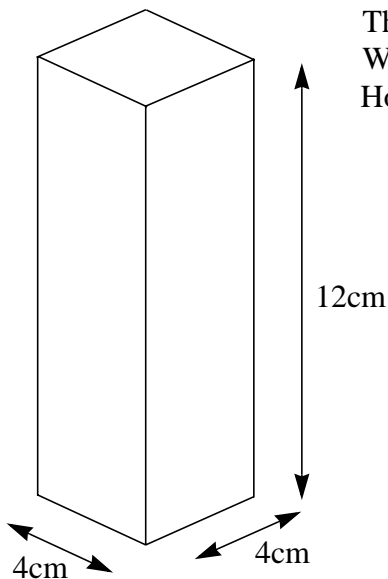

98. Volume 2

Exercise 1

Without using a calculator, change;

- | | |
|---|---|
| 1) 5cm^3 into mm^3 | 2) 0.02cm^3 into mm^3 |
| 3) 1000mm^3 into cm^3 | 4) $20,000\text{cm}^3$ into m^3 |
| 5) 4.2m^3 into cm^3 | 6) 0.1m^3 into cm^3 |
| 7) $20,000\text{mm}^3$ into cm^3 | 8) $420,000\text{cm}^3$ into m^3 |
| 9) 1.5m^3 into litres | 10) $100,000\text{ml}$ into litres |
| 11) 7.5 litres into ml | 12) 0.005 litres into ml. |

Exercise 2

- A large cardboard box has internal base dimensions of 50cm by 70cm and a height of 90cm . It is to be packed with smaller boxes measuring 10cm by 15cm by 25cm . How many boxes can be put on the bottom layer and how many of these layers can be put in altogether?
- A cardboard box is in the shape of a cuboid measuring 9cm by 20cm by 25cm . Calculate its volume.
- A trench 0.9m wide by 1.7m deep and 10 metres long is dug on a building site. Calculate the amount of earth removed.
- A water tank, in the shape of an open cuboid, has a base measuring 90cm by 45cm and a height of 60cm . How many litres of water will it hold?
- A cylindrical drinks can has a base of 7.5cm diameter and a height of 12cm . Calculate;
 - its volume in cm^3 and
 - its capacity correct to the nearest ml.
- A circular pond of 5m diameter and 40cm depth is filled with water. How many litres are needed?
- A metal tube has an outside diameter of 1.8cm and a thickness of 3mm . If its length is 1m , calculate the volume of metal it contains to the nearest cm^3 .
- A beaker is in the shape of a cylinder with a base diameter of 6cm and a height of 11cm . How many times can the beaker be completely filled from a jug holding 2.5 litres?
- An open tank, in the form of a cuboid, can hold 600 litres of water. If its base has dimensions of 80cm by 30cm , what is its height?
- A water tank, in the shape of an open cuboid, has a base measuring 40cm by 80cm and a height of 400cm . It has water in it to a depth of 25cm . A metal cube of sides 15cm is lowered into the water. By how much will the water rise?
- A drinking trough for animals is in the shape of a prism with a rectangular and semi circular end, as shown in the diagram.
 - What are the dimensions of the rectangular part of the end?
 - What is the area of the end?
 - The length of the trough is 3 metres. How many litres of water will it hold?

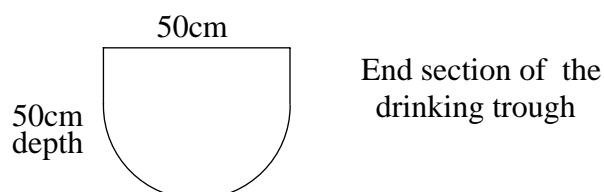

99. Formulae for Area, Volume and Perimeter 1

With each of the following shapes a number of formulae are given.
Decide which formula best satisfies the situation given.

1) Which formula could be used to find (a) the area (b) the perimeter?

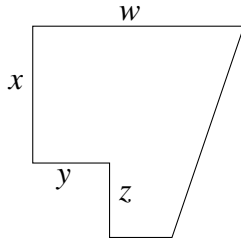

- | | |
|-----------------------|------------------------|
| (i) $wx + 3y + 4z$ | (ii) $wxy + yz - 3x$ |
| (iii) $wx + wz - 2yz$ | (iv) $x(w - y) + 2z$ |
| (v) $2w + 2x + z$ | (vi) $w + x + y + z^2$ |

2) Which formula could be used to find (a) the area (b) the perimeter?

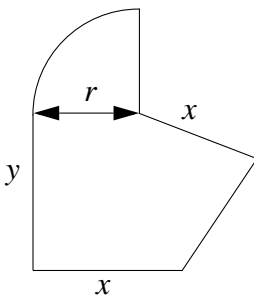

- | | |
|--|-------------------------------------|
| (i) $\frac{1}{4}\pi r^2 + 2x + \frac{5}{2}y$ | (ii) $\frac{1}{4}\pi r^2 + 3x + 4y$ |
| (iii) $\frac{1}{2}\pi r + 2x + y + \frac{3}{4}y^2$ | (iv) $\frac{1}{2}(\pi r + 4x + 3y)$ |
| (v) $\frac{1}{4}\pi r^2 + 1.2xy$ | (vi) $\frac{2}{3}\pi r + 3x + xy$ |

3) Which formula could be used to find (a) the volume (b) the surface area?

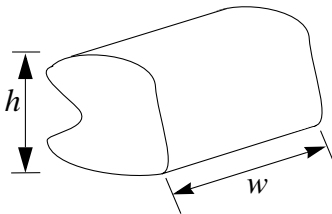

- | | |
|----------------------------|------------------------------|
| (i) $\frac{2}{3}h^2w$ | (ii) $\frac{2}{3}h^2 + w$ |
| (iii) $\frac{2}{3}h + w^2$ | (iv) $\frac{2}{3}h^2 + 3hw$ |
| (v) $\frac{2}{3}h + 3hw$ | (vi) $\frac{2}{3}h + hw + w$ |

4) Which formula could be used to find (a) the area (b) the perimeter?

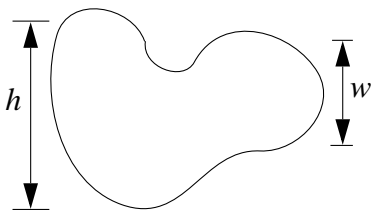

- | | |
|--------------------------------------|--------------------------------|
| (i) $6(h + w) - 2hw$ | (ii) $\frac{2}{3}h^2 + 4w$ |
| (iii) $3h + 3w$ | (iv) $\frac{1}{2}\pi(h^2 + w)$ |
| (v) $\frac{2}{3}\pi(h^2 + w^2) - 4h$ | (vi) $\frac{2}{3}(h^2 + w^2)$ |

5) In this bottle shape, which formula could be used to find (a) the volume
(b) the surface area?

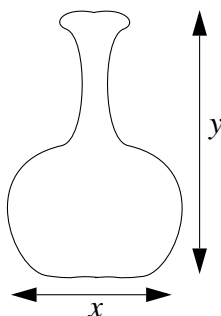

- | | |
|-----------------------------------|-----------------------------------|
| (i) $\frac{5}{7}\pi xy^2 - 7y^2$ | (ii) $\frac{1}{2}\pi xy$ |
| (iii) $\frac{5}{6}\pi x^2 - xy^2$ | (iv) $\frac{3}{2}\pi x^3 - 16y^2$ |
| (v) $\frac{1}{12}\pi x^2 y$ | (vi) $\frac{5}{8}x^2 y - 4xy$ |

100. Formulae for Area, Volume and Perimeter 2

- 1) An electrician installs the electrical wiring in new houses. She estimates the amount of cable needed for a house by using one of the formulae shown below, where L is the length of the front of the house, H is the height of the house and W is the distance from the front to the back of the house.

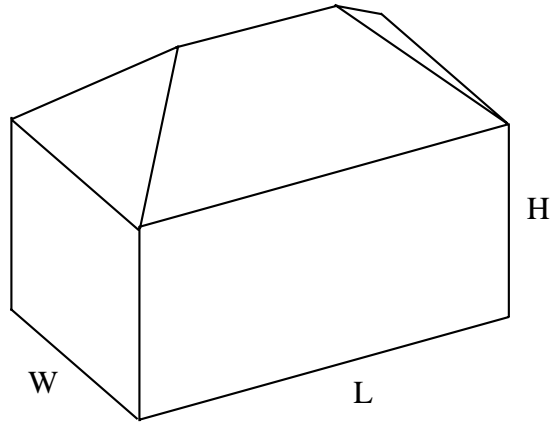

- a) $5L + 4W + 7H + 20$
 b) $L(3W + 9H)$
 c) $3LW + 4LH + 2HW$
 d) $24LWH$

- (i) Explain why you think that formula d is not the one she uses.
 (ii) Which formula do you think she uses? Explain how you come to this conclusion.

- 2) Which of the following formulae could represent (a) area, (b) volume and (c) perimeter?
 The letters a , b , c , d , x and y are dimensions measured in centimetres.

- | | |
|--------------------------------------|----------------------------------|
| 1) $ab + cd^2$ | 2) $a + b^2 + cd$ |
| 3) $a + x + y$ | 4) $ab + 2xy$ |
| 5) $\pi a^2 + b^2$ | 6) $3x + ab + c^2$ |
| 7) $axy + 3bac$ | 8) $5ax + \pi a + 3c$ |
| 9) $3(x + y)$ | 10) $\frac{1}{2}(7x + 14y - ax)$ |
| 11) $7xy + \pi ab$ | 12) $3xy - \pi y$ |
| 13) $3(xy^2 + 2x^2)$ | 14) $\pi(a^2 - b^2)$ |
| 15) $\frac{3(ax^2 + b^2)}{2}$ | 16) $\frac{5(a^2 + b^2)}{6}$ |
| 17) $5x + 7y - \frac{1}{3}ab$ | 18) $17x + \frac{2}{3}a - 3b$ |
| 19) $\frac{7x^2 - 3x^2a - 4ax^2}{7}$ | 20) $\frac{12x^3 - 3x^2y}{2}$ |

101. Time

1) The diagrams below show the start and finish times for some TV programmes. Calculate how long the programmes last.

a) Start

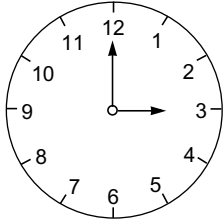

Finish

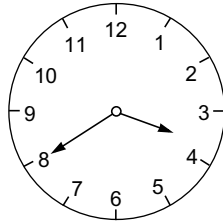

b)

Start

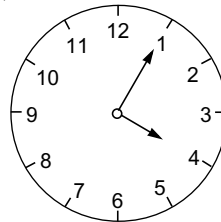

Finish

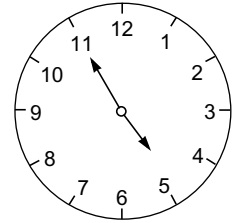

c) Start

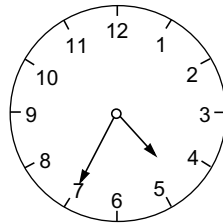

Finish

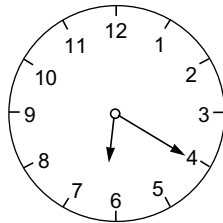

d)

Start

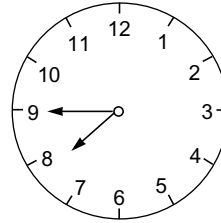

Finish

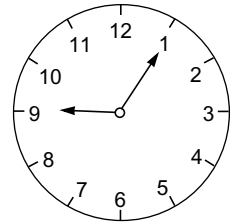

2) The following diagrams show the start and finishing times of rail journeys. Calculate how long the journeys take.

a) Start

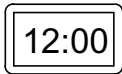

Finish

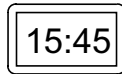

b) Start

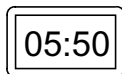

Finish

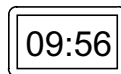

c) Start

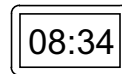

Finish

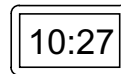

d) Start

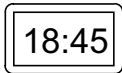

Finish

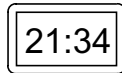

e) Start

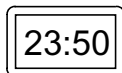

Finish

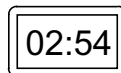

f) Start

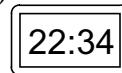

Finish

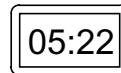

- 3) A TV programme begins at 3:30. It lasts for 2 hours 20 minutes. At what time will it end?
- 4) A train leaves a station at 11:45am and travels for 2 hours 45 minutes. At what time does it arrive at its destination?
- 5) Amy goes to a football match on Saturday afternoon. She leaves home at 11:35am and arrives back home at 6:15pm. How long was she away from home?
- 6) An aeroplane leaves Manchester at 15:53 and arrives at London Heathrow at 17:06.
 - a) What would these times be on the 12 hour clock?
 - b) How long is the journey from Manchester to Heathrow?
- 7) Joseph leaves home at 08:05 and takes 32 minutes to get to school. His sister, Hannah, leaves home at 07:51 and takes 39 minutes to get there. Who arrives at school first?
- 8) A car leaves Paris at 06:45 to travel to Marseilles. It arrives in Marseilles 9 hours 27 minutes later.
 - a) At what time does it arrive in Marseilles?
 - b) If the driver stopped on the way for 53 minutes, what was her total driving time?
- 9) A ferry leaves port at 22:43 on Tuesday. It arrives at its destination at 06:05 on Wednesday morning. How long did the journey take?

102. Density

1) These cubes measure 1cm by 1cm by 1cm.

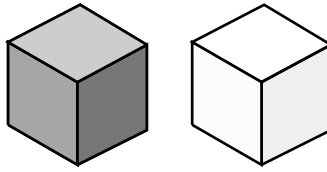

Their volumes are each 1cm^3 .

The weight of the black cube is 3g. The weight of the white cube is 2g.

Calculate the average weight of

(a) 3 black and 3 white cubes (b) 4 black and 6 white cubes

2) Red centimetre cubes weigh 4g and blue centimetre cubes weigh 5g. Find an arrangement of cubes which give an average density of 4.4g per cm^3 .

3) Can you list other arrangements of blue and red cubes which give an average density of 4.4g per cm^3 ?

4) Black cubes weigh 4g and white cubes weigh 5g.

(a)

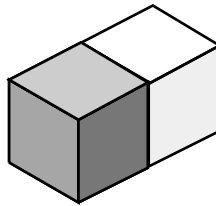

A black cube and a white cube are put together. What is their average density?

(b) If 2 black cubes and 4 white cubes are put together, what is their average density?

5) An alloy is made by putting together 14cm^3 of copper with 2cm^3 of zinc. 1cm^3 of copper has a mass of 9g and 1cm^3 of zinc has a mass of 7.1g.

a) What is the volume of the alloy produced?

b) What is the mass of the alloy?

c) What is the density, in g/cm^3 of the alloy?

6) An alloy is made by putting together 5cm^3 of copper with 12cm^3 of aluminium.

The density of copper is 9g/cm^3 and the density of aluminium is 2.7g/cm^3 .

a) What is the volume of the alloy produced?

b) What is the mass of the alloy?

c) What is the density, in g/cm^3 of the alloy?

7) Eighteen 1cm^3 metal blocks are put together to form a larger shape. Some of them are made from copper and have a density of 9g/cm^3 . The rest are of an alloy with a density of 3g/cm^3 . If the total mass of the blocks is 108g, how many copper blocks are there?

103. Best Buys and Painting

Exercise 1. Finding the best buy

Calculate which of the following sizes give the best buy.

- | | |
|---------------------------|--|
| 1) Margarine costing | 55p for a 250g pack
95p for a 500g pack
£1.60 for an 800g pack |
| 2) Lemonade costing | 30p for a 400ml can
65p for a 1 litre bottle
85p for a $1\frac{1}{2}$ litre bottle |
| 3) Tea bags costing | 80p for a pack of 40
£1.40 for a pack of 80
£3.00 for a pack of 150 |
| 4) Cornflakes costing | 99p for a pack of 500g
£1.20 for a pack of 750g
£1.50 for a pack of 1kg |
| 5) Tomato Ketchup costing | 45p for a bottle of 330g
65p for a bottle of 540g
80p for a bottle of 745g |

Exercise 2. Painting

- 1) Mr Jones decides to have his garden fence painted. The fence is 180cm high and its total length is 30 metres. He has both sides painted each with two coats. The can of paint says that 1 litre will cover 13m^2 .
 - a) What is the total area of fence that he has to cover?
 - b) How much paint will he use?
 - c) How much paint will he have to buy if each can holds 5 litres?

- 2) Ben has to paint the outside walls of his house in white paint. He has four sides of the house to cover. He estimates the area of the four walls he has to paint as 21m^2 , 19m^2 , 23m^2 , and 15m^2 .
 - a) What is the total area of wall which needs painting?
 - b) It says on the tin that 1 litre of paint will cover 5m^2 . How many litres of paint will he need to give the walls one coat?
 - c) He decides to give the house two coats. How many litres will he need now?
 - d) To ensure he has enough paint he decides to buy 20% more. How much paint does he now need?
 - e) If paint comes in 10 litre tins, how much should he buy?

104. Speed

- 1) The distance between two towns is 100 miles. It takes 2 hours to travel between the towns. What is the average speed?
- 2) The distance between two towns is 96 miles. Neil takes 3 hours to get from one town to the other. What is his average speed?
- 3) The distance between two towns is 200 kilometres. A car takes 5 hours to travel between the towns. What is its average speed?
- 4) The distance between Newcastle and Edinburgh is 105 miles. A car takes 4 hours to travel between the towns. What is its average speed?
- 5) The distance between London and Swansea is 190 miles. A train takes $2\frac{1}{2}$ hours to travel between the towns. a) How far does it travel each half hour? b) What is its average speed?
- 6) The distance between two towns is 135 kilometres. It takes $4\frac{1}{2}$ hours to travel between the towns. a) How far does it travel each half hour? What is the average speed?
- 7) The distance between two towns is 10 kilometres. It takes 15 minutes to travel between the towns. What is the average speed?
- 8) The distance between two towns is 25 miles. It takes 30 minutes to travel between the towns. What is the average speed?
- 9) The distance between two towns is 90 kilometres. It takes 1 hour 30 minutes to travel between the towns. What is the average speed?
- 10) A car travels at an average speed of 30 miles per hour. It takes 2 hours to travel between two towns. How far apart are they?
- 11) A car travels at an average speed of 25 miles per hour. It takes 3 hours to travel between two towns. How far apart are they?
- 12) A car travels at an average speed of 50 kilometres per hour. It takes $2\frac{1}{2}$ hours to travel between two towns. How far apart are they?
- 13) A Train travels at an average speed of 50 kilometres per hour. It takes $1\frac{1}{2}$ hours to travel between two towns. How far apart are they?
- 14) A car travels at an average speed of 36 miles per hour. It takes $3\frac{1}{2}$ hours to travel between two towns. How far apart are they?
- 15) Two towns are 80 km apart. If a train travels at an average speed of 40 kilometres per hour, how long does it take to make the journey?
- 16) Two towns are 60 km apart. A train travels at an average speed of 40 kilometres per hour between them. How long does it take to make the journey?
- 17) Manchester and Cardiff are 170 miles apart. A train travels at an average speed of 68 miles per hour between them. Jane leaves Manchester at 12:50. At what time will she arrive in Cardiff?
- 18) Two towns are 20 miles apart. A train leaves the first town at 10:15am. It travels to the other town at an average speed of 60 kilometres per hour. At what time will it arrive?
- 19) Two towns are 100 kilometres apart. A train travels between them at an average speed of 80 kilometres per hour. If it starts its journey at 11:30pm, at what time will it arrive at the second town?

105. More Best Buys

- 1) Matthew sells running socks on his market stall in packs of 3 for £1.71. He sees that the local supermarket sells the same socks in packs of 5 for £3.05. Who sells the cheaper socks?
- 2) Cassette tapes are sold in packs of 3 for £1.47 at the corner shop. In the supermarket they are sold in packs of 8 for £3.76. Showing all working, calculate which gives the best value for money.

3)

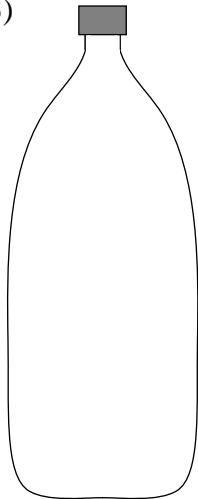

2 litres
95p

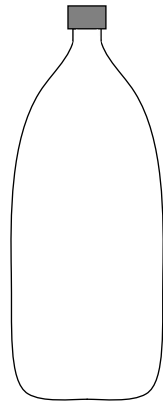

1 litre
45p

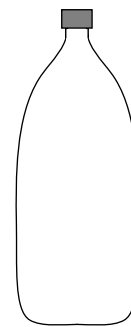

500ml
30p

Which of these three bottles of cola is the best value for money?
Show all your calculations.

- 4) Which of these tins of soup gives the best value for money?

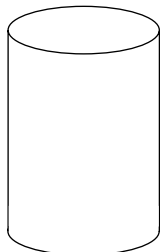

300 grammes
27p

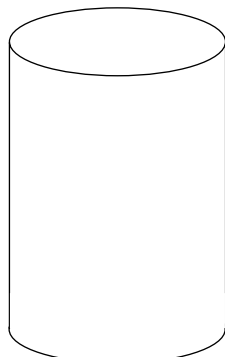

700 grammes
54p

- 5) Which of these two cartons of orange juice gives the best value for money?

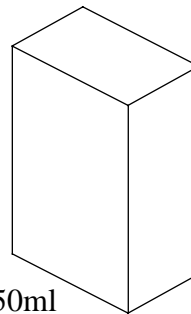

450ml
35p

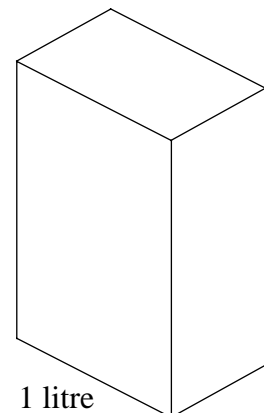

1 litre
60p

- 6) Toothpaste costs 90p for a 75ml tube or £1.20 for a 125ml tube. Showing all working, calculate the best buy.
- 7) Shampoo costs 60p for a 250ml bottle or £1.10 for a 500ml bottle. Showing all working, calculate the best buy.
- 8) Baked beans cost 22p for a 250g tin or 34p for a 450g tin. Showing all working, calculate the best buy.
- 9) Paint costs £2.55 for a 1 litre tin or £9.05 for a 4 litre tin. Showing all working, calculate the best buy.
- 10) Oil paint is sold in 2 different sizes. A 75ml tube costs £1.20 and a 200ml tube costs £3.10. Showing all working, calculate the best buy.

106. Pythagoras' Theorem

1) Calculate the length of the hypotenuse in each of the following triangles

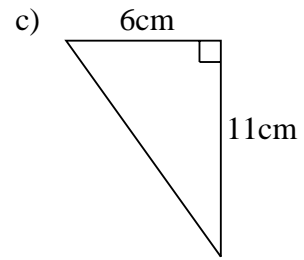
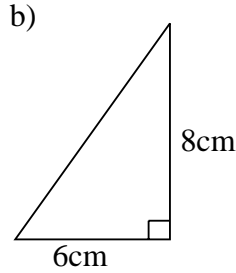
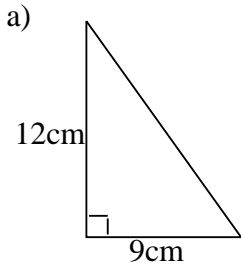

2) Calculate the length of the side marked x in each of the following right angled triangles.

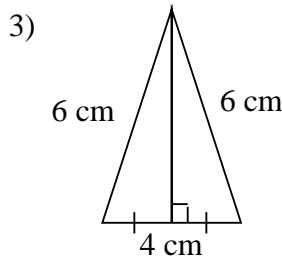
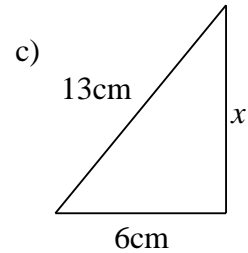
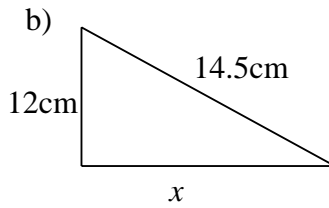
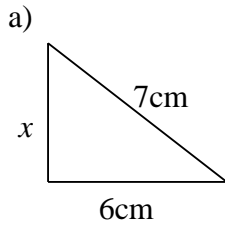

Calculate the height of this isosceles triangle

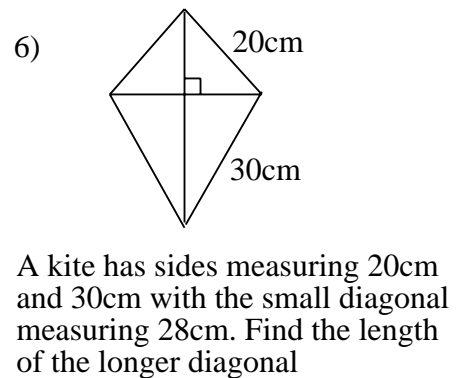
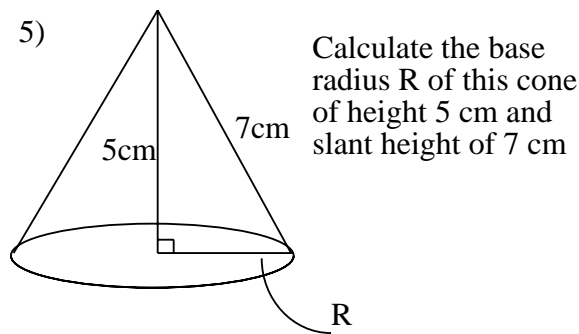
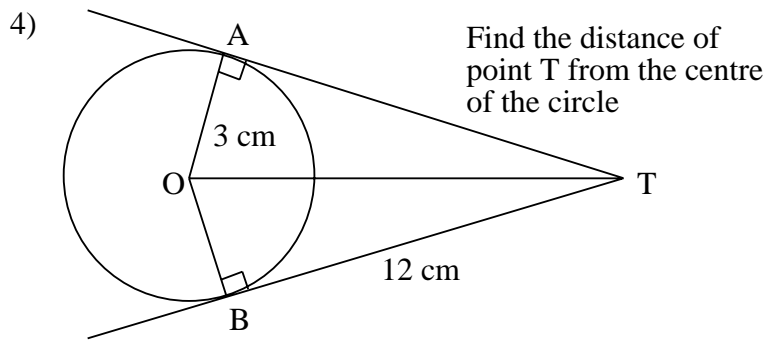

- 7) Calculate the length of the diagonal of a rectangle measuring 9cm by 12cm.
- 8) A rhombus has diagonals of 7cm and 4cm. Find the length of its sides.
- 9) A square has a side of 7cm. Find the length of its diagonals.
- 10) How far from the centre of a circle of radius 7cm is a chord of length 7cm
- 11) A ladder rests against a wall. The ladder is 5 metres long. The base of the ladder is 2m from the foot of the wall. How far up the wall will the ladder rest?
- 12) A ladder, 6 metres long, rests against the side of a house. The ladder reaches 5 metres up the side of the house. How far, to the nearest centimetre, is the bottom of the ladder from the base of the house?
- 13) Calculate the length of the side of a square whose diagonal is 12 cm.

107. Trigonometry 1

Use the sine ratio

1) Calculate the length of the unknown side (x) in each of the following triangles.

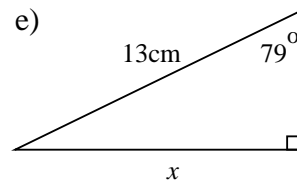
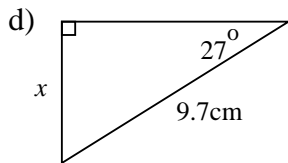
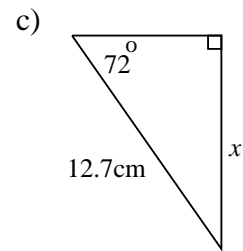
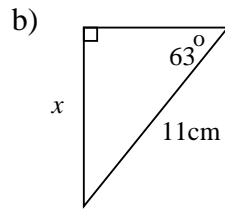
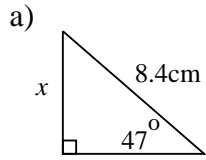

2) Calculate the sizes of the unknown angles in each of the following triangles.

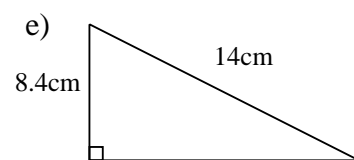
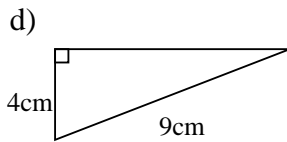
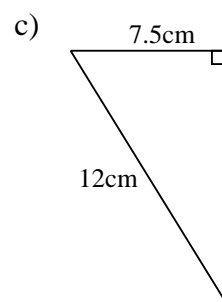
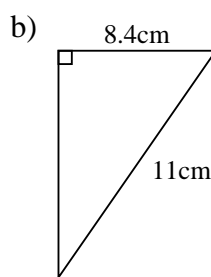
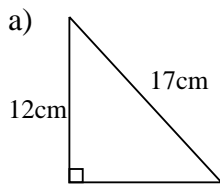

3) Calculate the length of the unknown side (x) in each of the following triangles

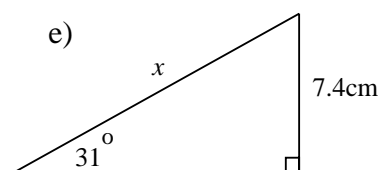
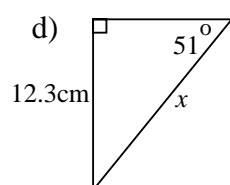
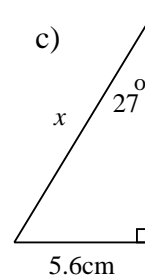
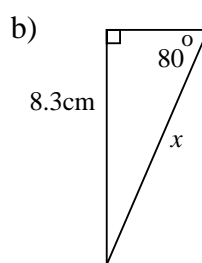
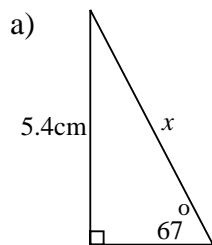

108. Trigonometry 2

Use the cosine ratio

1) Calculate the length of the unknown side (x) in each of the following triangles.

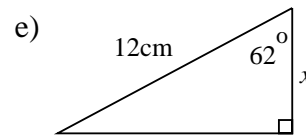
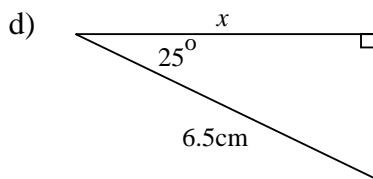
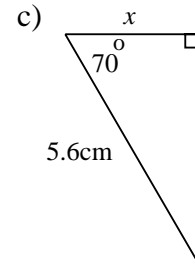
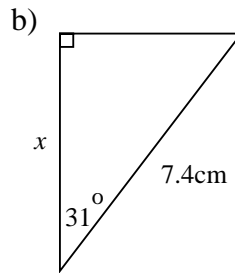
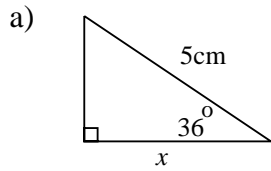

2) Calculate the sizes of the unknown angles in each of the following triangles.

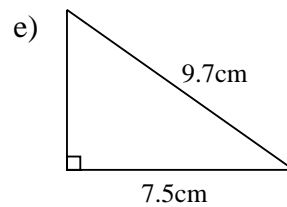
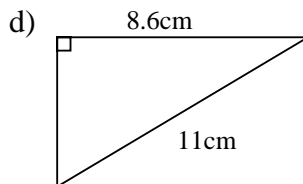
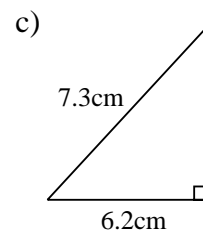
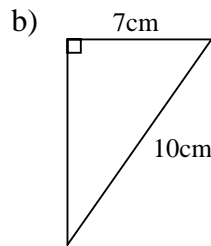
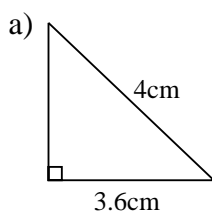

3) Calculate the length of the unknown side (x) in each of the following triangles

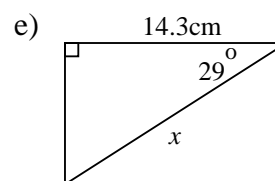
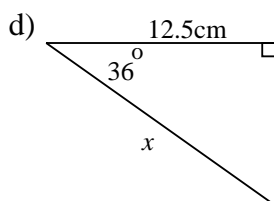
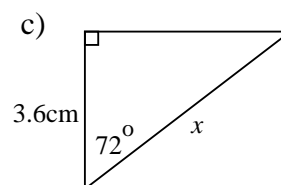
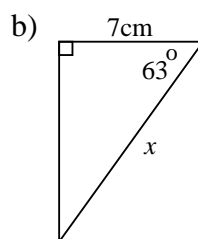
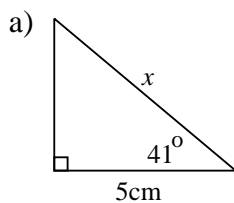

109. Trigonometry 3

Use the tangent ratio

1) Calculate the length of the unknown side (x) in each of the following triangles.

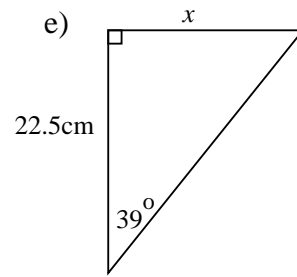
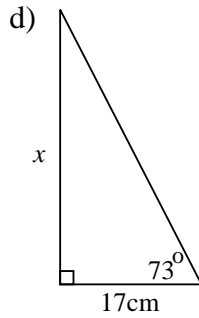
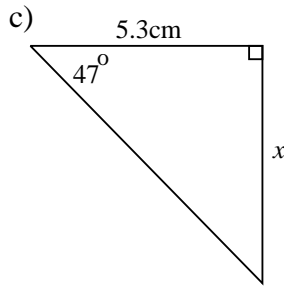
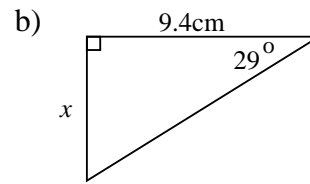
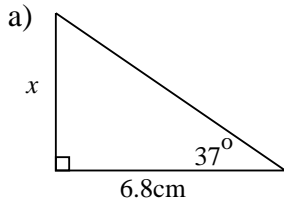

2) Calculate the sizes of the unknown angles in each of the following triangles.

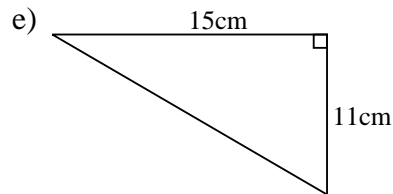
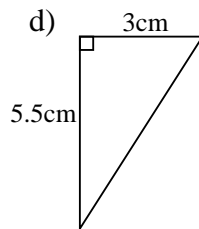
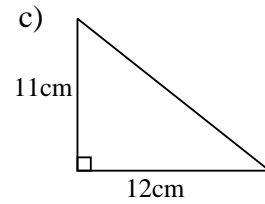
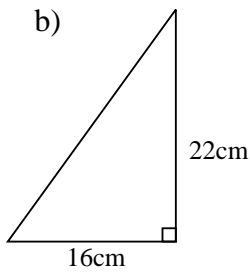
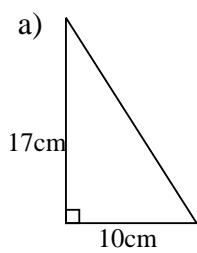

3) Calculate the length of the unknown side (x) in each of the following triangles.

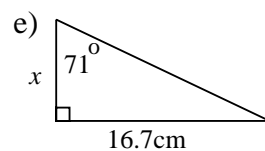
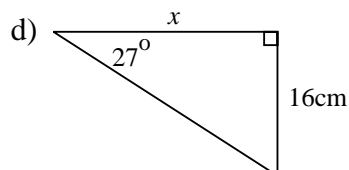
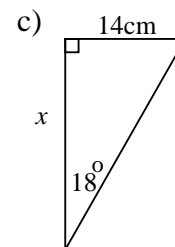
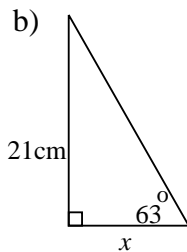
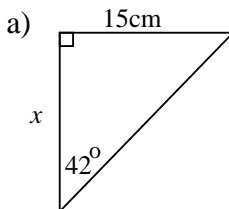

110. Trigonometry 4

Use the sine, cosine or tangent ratios.

a)

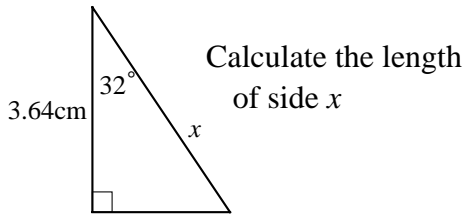

b)

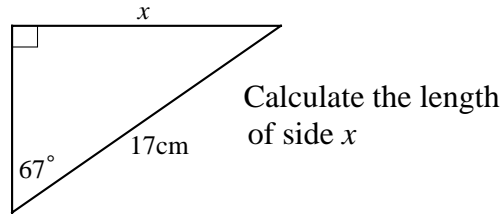

c)

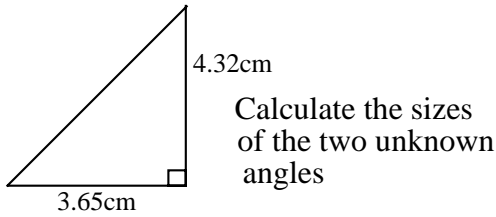

d)

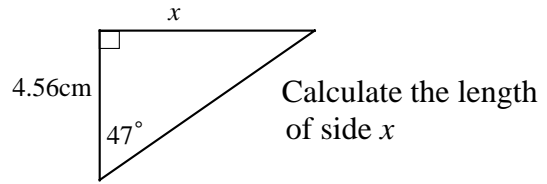

e)

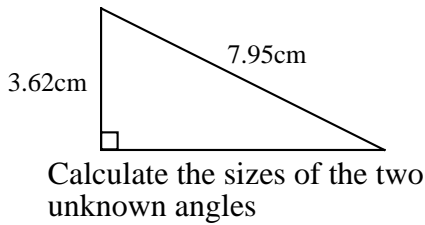

f)

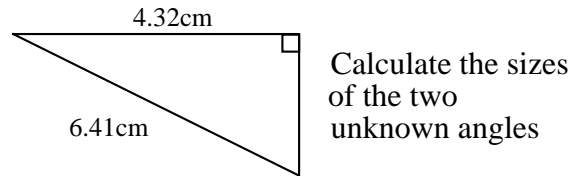

g)

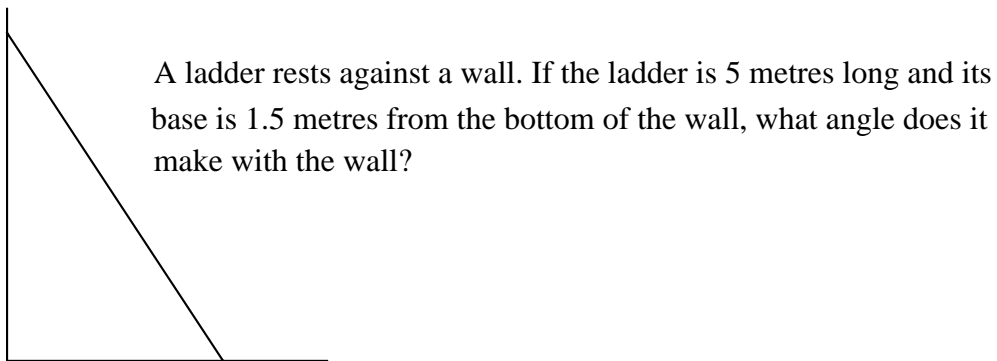

h)

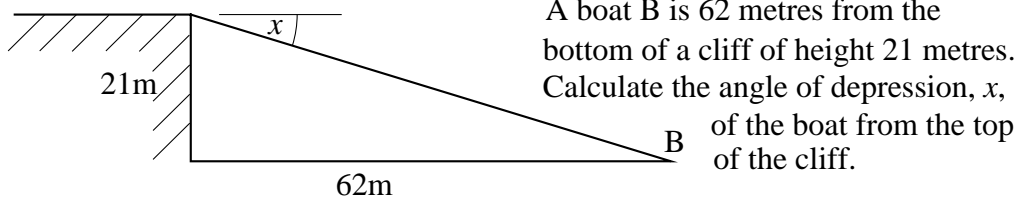

i) A ladder, 4.5 metres long, rests against a wall at an angle of 21° to the wall. How far up the wall does the ladder reach and how far is its base from the wall?

j) The angle between the diagonal and longest side of a rectangle is 34° . If the longest side measures 6cm, what is the length of the shortest side?

k) A swimming pool is 15 metres long. If its depth varies from 1 metre to 2.5 metres, at what angle to the horizontal is its base?

111. Surveys and Questionnaires

- 1) James did a survey. He asked the question “Do you think smoking is bad for your health?”
He carried out the survey at three different places, a) people coming out of a cigarette factory, b) a group of nurses and doctors and c) the customers at a supermarket.
The results he gained were (i) yes 97%, no 3% (ii) yes 70%, no 30%, (iii) yes 30%, no 70%.
Which set is which?

- 2) A large retail company want to build a department store in the middle of town.
Sandra does a survey to find out if the local people want it and whether they will use it.
 - (i) Write down three questions she might ask.
 - (ii) What do you think the responses might be?





- 3) Will wants to set up a small stall in the local market selling sandwiches.
He decides to sell five basic sandwiches. They are:
bacon, lettuce and tomato
prawn salad
chicken tikka
smoked salmon and
cheese and tomato.
Devise a questionnaire so that Will can survey the market customers.
You need to know (i) whether the public want a sandwich bar (ii) the types of sandwiches they like.

- 4) The town council want to make the local cinema into a night-club. The town has four other night-clubs. The cinema is the last remaining one in town (forty years ago there were seven).
As well as showing the latest films it has special showings for the local pensioners every Wednesday morning and the town’s film club meet there once a month.
Some of the inhabitants set up a pressure group to stop this happening. They call themselves SOC (save our cinema). They want as many people as possible to sign a petition.
 - a) What should the petition say?
The local council ask what the general public think. They produce a questionnaire.
 - b) In general, what do you feel that the following groups of people think of the idea of having a fifth night-club in town? Explain your answers.
 - (i) Young people between 10 and 16?
 - (ii) Young people aged between 16 and 30?
 - (iii) Mums and Dads with young children
 - (iv) Pensioners



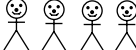
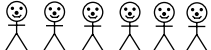

112. Pictograms



1) The diagram represents the method by which year 7 get to school. From the diagram determine:

- a) The total number of pupils in the year.
- b) The number of pupils who travelled by bus.
- c) The number of pupils who travel by train.

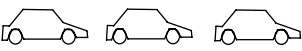
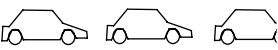
	 represents 5 pupils	Frequency
Walk		10
Bus		
Car		
Bicycle		
Train		
Other		

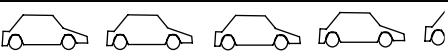
2) The pictogram shows the number of cars travelling past Sarah’s home between 7:00am and 1:00pm.

Time	 represents 60 cars	Frequency
7:00-8:00		210
8:00-9:00		
9:00-10:00		
10:00-11:00		
11:00-12:00		
12:00-13:00		

- a) How many cars does  represent?
- b) How many cars does  represent?
- c) How many cars does  represent?
- d) How many cars went past between 9:00am and 1:00pm?

3) A survey was carried out to determine which of five sports was the most popular. 100 people were asked which of the sports they liked best. Here are the results.

Badminton	Squash	Netball	Rounders	Hockey
20	10	20	15	35

Draw a pictogram to show this data using  to represent 5 people.

113. Pie Charts 1

1) The pie chart shows the mixture of trees in a wood.

There are 1000 trees altogether.

- What percentage of trees are ash?
- What fraction of trees are oak?
- How many oak trees are there

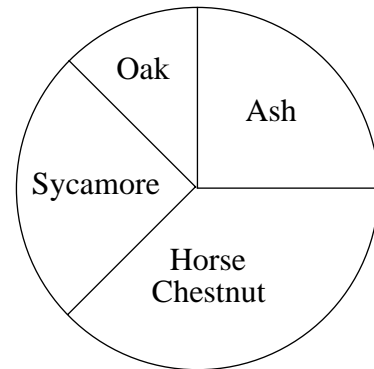

2) This pie chart represents Charlotte's daily activities.

- What fraction of the day is spent sleeping?
- How many hours are spent working?

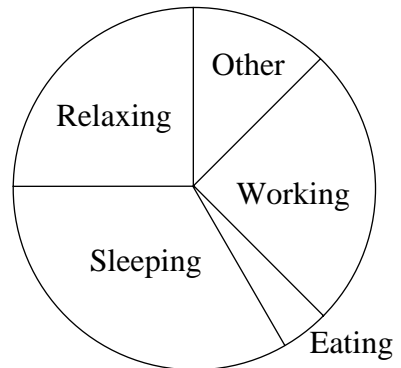

3) A survey asked 90 people how they intended to vote in the next general election.

The results are shown in the table below.

Conservative	Labour	Liberal democrat	Other	Not known
20	30	20	5	15

Draw a pie chart of this information. You must show clearly all your calculations.

4) A class of 36 pupils were asked how they normally came to school. 10 said they came by bus, 14 walked, 7 came by car and 5 by bicycle.

Draw a pie chart to show this information. Calculate:

- the number of degrees representing 1 pupil.
- the number of degrees representing each of the groups.

5) A survey was carried out to determine the type of newspapers read. The 120 replies are shown in the table below.

Local	Daily	Sunday	None
20	30	5	15

Draw a pie chart to show this information.

6) In a library there are 600 shelves to hold the books. The shelves are used in the following way

Reference	Fiction	Non-fiction	Magazines and newspapers
100	250	200	50

Draw a pie chart for the information by first calculating;

- the angle needed to represent 10 shelves.
- the number of degrees needed for each group.

114. Pie Charts 2

- 1) A class of 36 pupils were asked how they normally came to school. 15 said they came by bus, 10 walked, 8 came by car and 3 by bicycle.

Draw a pie chart to show this information by first calculating

- the number of degrees representing 1 pupil and hence
- the number of degrees representing each of the groups.

- 2) The number of people, correct to the nearest 100, who visited the town's attractions one week in January were

Zoo 600

Cathedral 400

Castle 700

Museum and Gallery 500

Others 200

- Draw a pie chart to show this.
- In July all of the attractions increased their visitors by 50%. What would the new pie chart look like?

- 3) Holly and Ben both live in flats. The diagrams below show how they spend their wages on 'essentials'

Ben's pie chart

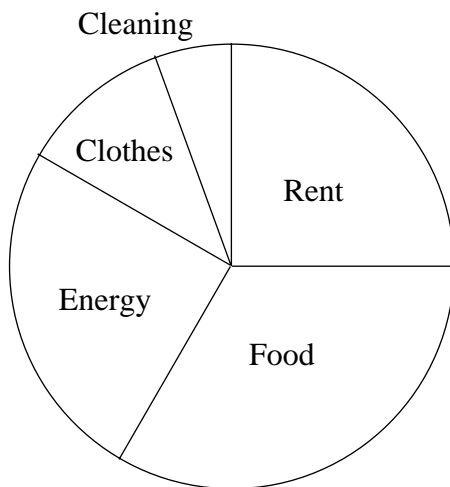

Holly's pie chart

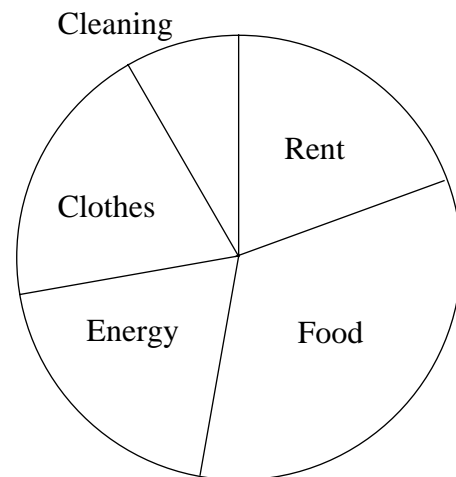

- If they both spend the same amount of money each week, answer these questions:
 - Who spends the most on rent?
 - Who spends the most on cleaning?
 - What percentage of Ben's money is spent on energy?
 - What percentage of Holly's money is spent on energy?
- If Holly spends less money than Ben, answer these questions:
 - Who spends the most money on energy?
 - Who spends the most money on food? Explain your answer.

115. Bar Charts

1) This bar shows the types of houses the pupils of 10G live in.

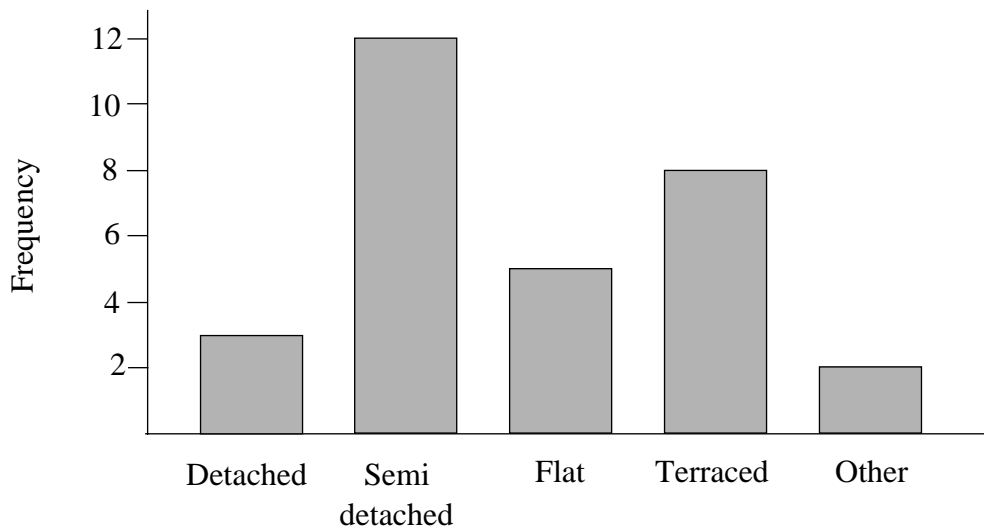

From the diagram determine:

- Which type of building is the most common.
- The number of pupils who live in flats.
- The total number of pupils in 10G.

2) The bar chart shows the marks obtained in an examination by students in a college. For example, 50 students scored between 40 and 49 marks.

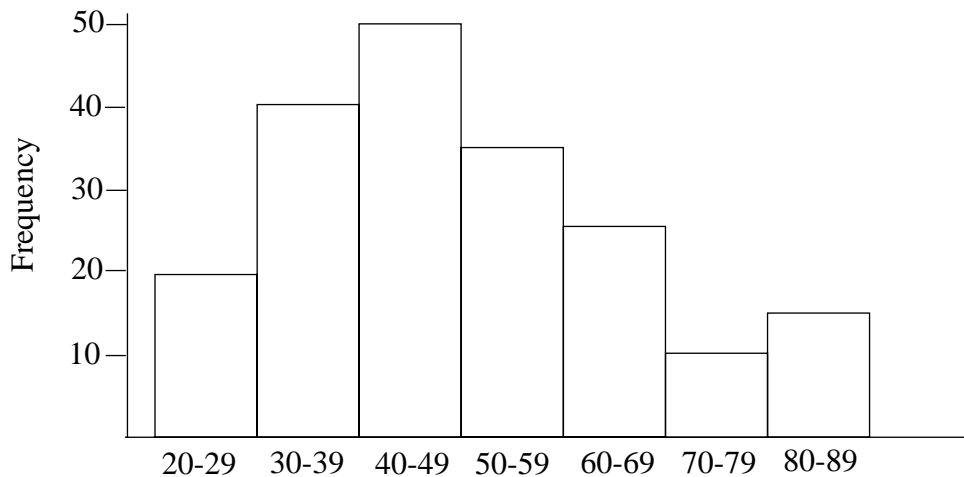

- How many students scored between 30 and 39?
- How many students scored between 50 and 59?
- How many students scored 60 or more?
- Approximately how many students sat the examination?

3) Sixty people were asked to name their favourite fruit. The results are shown in this table.

Apple	Banana	Orange	Pear	Grapes	Other
13	18	10	6	8	5

Draw a bar chart to show this information.

116. Stem and Leaf diagrams

1) Below is shown a stem and leaf diagram for some data.

```

2  4, 5, 2, 0, 4, 6, 5
3  0, 0, 3, 4, 2, 9, 4, 6, 7, 3, 1, 1, 0
4  4, 4, 7, 5, 0, 2, 4, 6, 5, 9, 2, 2
5  1, 6, 4, 0, 5, 7, 3
6  4, 0, 2, 4
7  6, 5, 9

```

- What value does the 5 represent in the 'stem' column?
- How many values of 42 are there in the table?

2) The number of radios sold by a shop over a 24 week period are shown in the table below.

20,	25,	34,	42,	39,	51,	37,	32,	29,	60,	36,	41,
26,	54,	42,	45,	37,	32,	36,	44,	50,	26,	34,	22

Darren draws a stem and leaf diagram for this data. This is what he got.

```

2  0,5,9,6
3  4,9,7,2,6,7,2,6
4  2,1,2,5
5  1,4
6  0

```

- Write down the actual values of the stems.
- Darren has not finished the diagram. Redraw and complete it.

3) Below is shown a stem and leaf diagram for some data.

```

08  3, 5, 6, 0, 0, 1, 3
09  0, 8, 3, 5, 2, 9, 0, 6, 3, 3, 1, 1, 1
10  5, 4, 2, 5, 0, 1, 4, 8, 5, 4, 2
11  2, 7, 5, 0, 8, 8
12  0, 0, 4, 1
13  4, 6
14  3

```

- How many items of data is there altogether?
- What are the largest and smallest values?
- What is the range for this data?

4) The table below shows the number of people who visit a sports centre each day over a period of one month

196,	215,	222,	461,	485,	514,	314,	231,	190,	472,
257,	206,	594,	314,	410,	185,	422,	438,	365,	542,
361,	436	185,	374,	407,	394,	608,	533,	412,	434

- If the data is to be arranged into 6 rows, what are the values of the stems?
- Draw a stem and leaf diagram for the data.

117. Box Plots

1) The diagram below shows a vertical box plot representing the marks obtained in a science examination by year 10 pupils.

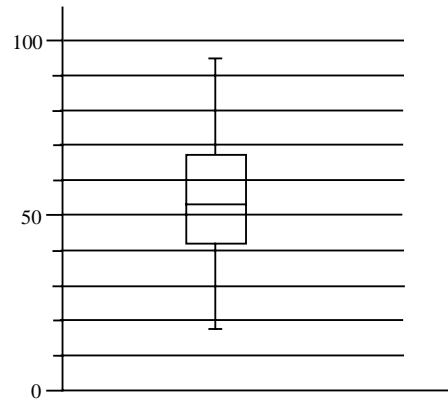

Use the diagram to estimate the following.

- a) What was the highest score?
 - b) What was the lowest score?
 - c) What was the median score?
 - d) What was the lower quartile?
 - e) What was the upper quartile?
 - f) If there are 150 pupils in the year, how many scored between the lower and upper quartiles?
 - g) How many pupils scored less than the median?
- 2) At a factory there are 600 full time employees who are paid at the end of each month. The following figures relate to their pay for January.

Highest wage £3,500
 Lowest wage £1,100
 Lower quartile £1,500
 Upper quartile £2,100
 Median £1,800

Represent this information on a horizontal box plot.

3) The box plot below represents the ages of male members of a fitness club.

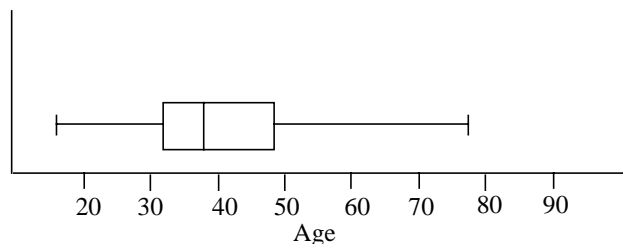

The following values represent the female members.

Lowest age 19 Highest age 84
 Lower quartile 37 Upper quartile 53
 Median age 46

Copy the box plot for the male members and on the same diagram show the values for the female members. Comment on the differences between the male and female results.

118. Line Graphs

- 1) The table shows the temperatures at two places, one in Europe and the other in Australia. The values are given for the months January, March, May, July, September and November.

Month	Jan	Mar	May	July	Sept	Nov
Temperature in Europe °C	9	15	20	28	25	14
Temperature in Australia °C	27	32	23	13	12	20

This graph shows the temperatures for Europe plotted against the months.

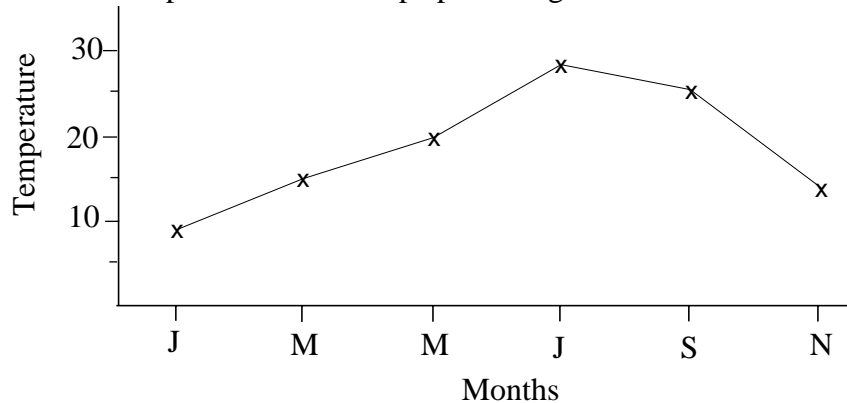

- a) Plot the values for Australia on a similar graph.
 b) Compare the two graphs. What do you notice about the temperatures in Europe compared with those in Australia?
- 2) A company makes egg timers. They are supposed to run for exactly 4 minutes. A sample of 100 were tested and the times they gave are shown below.

Time (seconds)	237	238	239	240	241	242
Frequency	10	14	18	30	17	11

- a) Copy and complete this line graph for the table.

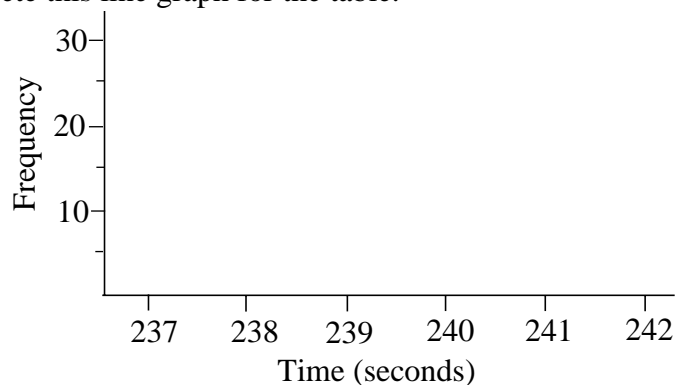

- b) Use the graph to comment on the results.
- 3) The table below shows the heights of 20 tomato plants. Draw a line graph for the values. Let the horizontal axis represent the heights. Let the vertical axis represent the frequency.

Height of tomato plant	89cm	90cm	91cm	92cm	93cm
Frequency	2	4	5	6	3

119. Scatter Diagrams 1

1) The diagram shows three different types of scatter graphs.

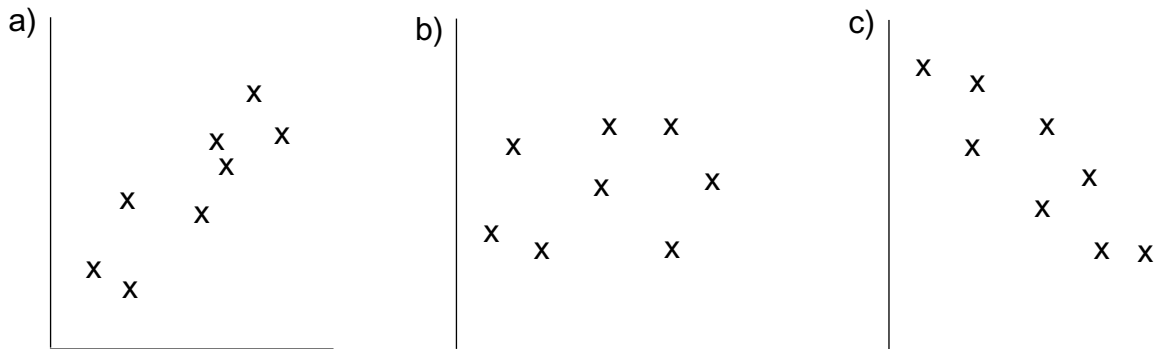

Describe each of the different kinds of correlation.

The diagrams represent these three situations:

- (i) the age of cars plotted against their value.
- (ii) The number of rooms in a house plotted against the value of the house.
- (iii) the age of adults plotted against their weight.

Which diagrams represent each of the situations?

2) A class of pupils sat an examination in mathematics.

The examination consisted of two papers.

The following table shows the marks scored by a sample of 10 pupils.

Paper 1	46	77	49	57	67	52	72	59	54	27
Paper 2	53	84	43	63	65	61	74	73	57	35

On graph paper plot these values. Put paper 1 on the horizontal axis and paper 2 on the vertical axis. Use 2cm to represent 10 marks on each axis.

From this diagram answer these two questions.

- a) A pupil missed paper 2 but got 53 on paper 1.
What was her estimated mark for paper 2?
- b) Another pupil missed paper 1 but got 70 on paper 2.
What was her estimated mark for paper 1?

3) The table shows the number of hours of rainfall each day at Northend-on-Sea and the number of deckchairs hired out each day over a period of one week.

Hours of Rainfall	2	5	3	0	7	10	8
No. of deckchairs hired out	150	100	160	190	45	10	70

On graph paper plot these values. Show the hours horizontally allowing 2cm to represent 2 hours. Plot the deck chairs vertically allowing 2cm to represent 20 chairs.

From your graph predict how many deck chairs would be hired out if there were 6 hour of rainfall.

120. Scatter Diagrams 2

Draw a scatter diagram for each of the following results. Draw a line of best fit and use it to answer each of the questions. You must show clearly on your diagram how you get your answer.

- 1) A class of pupils sat an examination in mathematics. The examination consisted of two papers. The following table shows the marks scored by a sample of 10 of the pupils.

Paper 1	46	77	49	57	67	52	72	59	54	27
Paper 2	53	84	43	63	65	61	74	73	57	35

- a) A pupil missed paper 2 but got 53 on paper 1. What was her estimated mark for paper 2?
 b) Another pupil missed paper 1 but got 84 on paper 2. What was her estimated mark for paper 1?
- 2) A garden centre raises plants from seed. The gardener puts the seeds into trays of different sizes. When they have germinated he takes one tray of each size and checks how many plants have germinated.

No of seeds in tray	10	20	24	36	50	100
No of plants germinated	8	17	23	34	45	79

He finds that he has forgotten to check a tray which holds 70 seeds. How many plants would he expect from it?

- 3) The heights and weights of 7 ladies are shown in the table below.

Height (cm)	150	153	155	160	162	168	170
Weight (kg)	51	51	57	60	61	62	63

Estimate the weight of a woman whose height is 158cm.

- 4) A survey is carried out into the sizes of 10 apple trees in a garden. The height is measured (using trigonometry) and the circumference of its trunk is measured one metre from the ground. This is a table of the results obtained.

Circumference cm	8	7	9	10.5	13	15	15.5	18	20
Height metres	3.9	4.1	4.3	4.6	4.8	4.7	5.1	5.0	4.8

What is the approximate circumference of a tree whose height is 4.5m?

- 5) The table shows the number of hours of rainfall per day at Northend-on-sea and the number of deck chairs hired out each day over a period of one week.

Hours of rainfall	2	5	3	0	7	10	3
No of deck chairs hired out	150	100	160	190	45	10	155

From your graph predict how many deck chairs would be hired out if there were 8 hours of rainfall.

121. Mean 1

1) Calculate the mean of these numbers.

3 7 5 6 5 4 5 3

2) Calculate the mean of these numbers, correct to one decimal place.

8 6 6 5 8 9 5 10 8 6 4

3) Calculate the mean of these numbers.

52 56 53 48 54 50 58 55 51 49 57

4) Calculate the mean of these numbers.

13 5 10 11 12 13 14 15 10 12

5) A cricketer plays in seven games and scores a total of 224 runs.

- What was his mean score?
- If he scores 0 runs in his eighth game, what is his new mean?

6) Barchester United Football Club score an average of 2.5 goals in 6 games.

- What was their total score?
- In the next game they score 5 goals. Is this sufficient to bring their average up to 3?

7) A class of 30 pupils have a test. It is marked out of 5. The table shows the marks gained.

Mark gained	0	1	2	3	4	5
Number of pupils	2	2	5	10	7	4
Total marks gained	0	2	10			

- How are the numbers in the bottom row obtained?
 - Complete the bottom row.
 - What was the total number of marks obtained by all the pupils in the class?
 - What was the mean mark?
- 8) 26 pupils in a class are asked how many brothers and sisters they have. The results are shown in the table below

Brothers or sisters	0	1	2	3	4	5
Number of pupils	2	4	8	6	3	3

- Calculate the total number of brothers and sisters.
 - What is the mean number of brothers and sisters?
- 9) Emma did a survey of 12 people. She asked them how many TV's they had in their house. She worked out the mean to be 2.5.

This is the data she collected

5 2 3 3 3 4 2 2 1 1 0

When she checked the data she found one to be missing. What was the number?

122. Mean 2

1. Find the average speed of a car which travels 94 miles in 3 hours, then 58 miles in 2 hours and finally 87 miles in 2 hours.
2. The car in question 1 returns home in 6 hours. What is the average speed for the complete journey?
3. A batsman scores 73, 47, 52, 83, 24, 19 and 7 in 7 innings. What is his batting average?
4. The cricketer in question 3 scored 0 (zero) in his eighth innings. What was his new batting average?
5. A car makes the following journeys.
23 miles in city traffic using $1\frac{1}{2}$ gallons of petrol, 86 miles on the motorway using 2 gallons of petrol and 93 miles on country roads using 3 gallons of petrol. Calculate the average fuel consumption of the car in miles per gallon.
6. A cricketer has a batting average of 37 runs per innings over 7 innings. During his next three innings he scores 16, 27 and 0. What is his new batting average?
7. A certain type of vegetable is classed as grade 1, grade 2 or grade 3. Grade 1 have an average weight of less than 50 grams, Grade 2 from 50 grams to 100 grams and Grade 3 more than 100 grams. What grade are the following
 - (a) A bag weighing 2kg containing 35 vegetables.
 - (b) A bag weighing 5 kg containing 45 vegetables.
 - (c) A bag weighing $2\frac{1}{2}$ kg containing 65 vegetables.
 If the three bags are mixed together, what grade would they be sold as?
8. Danielle keeps records of how much petrol her car uses. She finds that after servicing the car she gets a better fuel consumption. These are her figures for last year.

Month	Speedometer reading (miles)		Petrol used
	Beginning	End	Litres
January	23247	23407	15
February	23407	23577	16
March	23577	23745	16
April	23745	23902	15
May	23902	24091	18
June	24091	24234	14
July	24234	24426	19
August	24426	26390	194
September	26390	26543	15
October	26543	26684	13
November	26684	26855	16
December	26855	27014	15

Calculate her average fuel consumption for each month (in miles per litre)
Use these figures to determine in which month she had the car serviced

123. Mean 3

Find the mean value for each of the following sets of frequencies, correct to 4 significant figures.

1. The number of children in the families of pupils in a class.

No. of children in a family	frequency
1	7
2	13
3	5
4	2
5	1
7	1

2. The number of absentees from a class during a period of 60 days.

No. of absentees	frequency (days absent)
0	9
1	12
2	15
3	11
4	6
5	4
6	2
7	1

3. The number of broken glasses found when 1500 boxes, each containing 6 glasses were opened.

No. of broken glasses	frequency
0	1337
1	76
2	49
3	21
4	10
5	6
6	1

- 4) Packets of sweets each contain 24 sweets. The number of red sweets were counted in a sample of 100 packets.

Number of red sweets (number of packets)	frequency
3	5
4	12
5	33
6	23
7	18
8	9

124. Mean 4

1) The goals scored by 120 teams on a Saturday are shown below in the diagram. Calculate the mean number of goals scored.

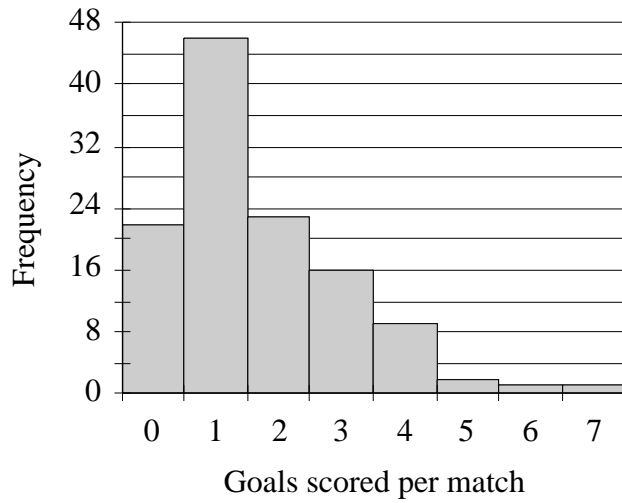

2) The diagram shows the marks obtained by year 10 in an examination. Calculate the mean mark.

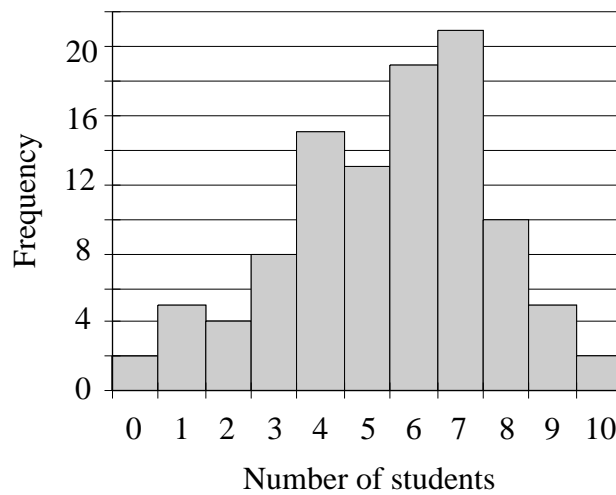

3) Jane carries out a survey to find the number of brothers and sisters year 8 pupils have. The results are shown in the diagram. Calculate the mean number they have

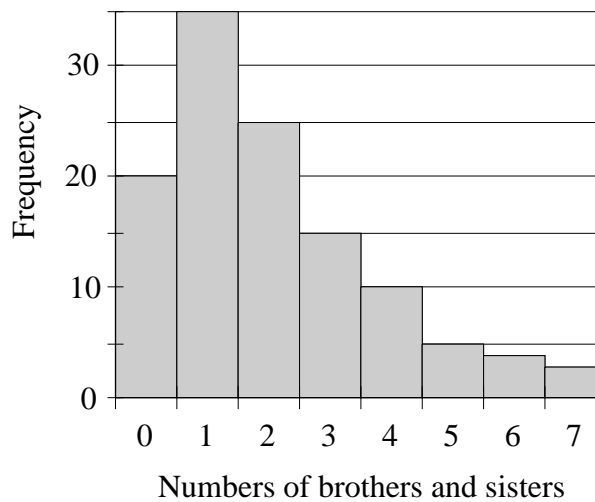

125. Mean 5

By first finding the mid value of each class interval, calculate an approximate mean for each of the tables of values shown below. State also the modal class in each case.

1. This table shows the heights of a sample of pupils in a school.

Height of child(cm)	Frequency	
120 < h ≤ 130	2	
130 < h ≤ 140	5	
140 < h ≤ 150	23	
150 < h ≤ 160	55	
160 < h ≤ 170	27	Give your answer correct to the nearest millimetre.
170 < h ≤ 180	14	

2. This table shows the weights, in grammes, of 5kg bags of potatoes.

Weight of bag	Frequency	
5000 < w ≤ 5010	76	
5010 < w ≤ 5020	54	
5020 < w ≤ 5030	48	
5030 < w ≤ 5040	12	
5040 < w ≤ 5050	7	Give your answer correct to the nearest gramme.
5050 < w ≤ 5060	3	

3. This table shows the weekly wage for employees in a factory.

Wage	Frequency	
40 < £ ≤ 80	7	
80 < £ ≤ 120	16	
120 < £ ≤ 160	23	
160 < £ ≤ 200	27	
200 < £ ≤ 240	31	
240 < £ ≤ 280	43	
280 < £ ≤ 320	45	Give your answer correct to the nearest penny.
320 < £ ≤ 360	12	

4. The life, in hours, of batteries tested by a manufacturer.

Life (hours)	Frequency	
10 < h ≤ 15	2	
15 < h ≤ 20	9	
20 < h ≤ 25	27	
25 < h ≤ 30	43	
30 < h ≤ 35	33	
35 < h ≤ 40	19	Give your answer correct to the nearest minute.
40 < h ≤ 45	6	

5. This table shows the heights of tomato plants ranging from 39 cms to 46 cms.

Height of plant	Frequency	
39 < h ≤ 40	4	
40 < h ≤ 41	10	
41 < h ≤ 42	14	
42 < h ≤ 43	17	
43 < h ≤ 44	10	
44 < h ≤ 45	5	Give your answer correct to the nearest millimetre.
45 < h ≤ 46	2	

126. Grouped Frequency

1) Below is shown a list of marks scored by 33 pupils in an examination.

40	35	56	98	56	87	43	23	54	57	19
39	53	85	67	83	35	49	28	51	62	68
58	43	23	73	80	52	48	33	43	21	58

Copy and complete this grouped frequency table for the marks.

Mark Class interval	Tally	Number of pupils Frequency
0 - 10		
11 - 20	/	
21 - 30	////	
31 - 40		
41 - 50		
51 - 60		
61 - 70		
71 - 80		
81 - 90		
91 - 100		

2) “From his window Jack could see the leafless trees on the far side of the railway cutting. There was a slight wind which from time to time rustled the discarded paper on the ground. And *there* was the magpie; the bird that had given him so much trouble in the past”.
From the paragraph above, complete this table.

Number of letters in a word Class interval	Tally	Number of words Frequency
1 - 2		
3 - 4		
5 - 6		
7 - 8		
9 - 10		

3) Below is shown the number of TV’s sold each day by an electrical shop over a period of six weeks (36 days - excluding Sundays)

5	4	8	11	15	14	3	13	8	13	19	19
13	15	10	15	21	15	9	6	8	14	8	14
4	5	1	8	2	3	4	6	4	3	1	2

Copy and complete this grouped frequency table.

Number sold Class interval	Tally	Number of days Frequency
1 - 4		
5 - 8		
9 - 12		
13 - 16		
17 - 20		
21 - 24		

127. Median, Mode and Range

1) Copy and complete the frequency table for these numbers

2 3 3 3 4 2 6 1 5
 1 1 4 4 3 5 2 3 2
 1 1 1 3 1 5 4 5 1
 2 2 2 3 4 7 6 4 6

Number	Tally	Frequency

From the table determine:

a) the mode and b) the range.

2) Construct a frequency table for these numbers

1 4 7 4 3 8 0 2 1 8
 2 9 2 6 0 8 2 2 6 2
 8 1 9 0 3 7 1 0 7 5
 1 9 8 3 2 6 2 6 0 2
 5 2 8 7 3 0 1 2 3 4

From the table determine a) the mode and b) the range of the numbers.

3) Construct a frequency table from the following numbers. From the table determine:

a) the mode and b) the range.

13 14 17 14 15 14 17 14 13
 16 15 13 16 17 15 13 16 17
 17 16 14 15 13 17 14 16 16
 15 15 15 14 14 15 15 15 13
 15 16 13 15 14 16 14 17 15

4) Re-arrange the following numbers into order of size. From the list determine the median and the range.

8 7 4 10 1 5 6 6 5 4 3 4 8 7 10 4 9 5 3 2 7

5) Determine the median and range of these numbers.

9 9 7 6 7 4 3 2 3 7 7 6 5 7 5 8 5

6) Determine the median and range of these numbers.

70 72 30 74 80 83 36 50 38 85 92 50 70
 68 17 48 77 72 60 74 14 75 83 65 33 52

128. Mean, Median, Mode and Range

1) A car manufacturer designs a family car. She knows that the mean number of people in a family is 4.4 and the mode is 4. How many seats should she put in the car? Explain your answer.

2) The following table shows the ages of the people at a youth club.

Age	Less than 14	14	15	16	over 16
Number of people	10	16	20	15	12

Explain why the mean cannot be calculated.

3) Eleanor carries out a survey on two groups of people.

The first group she calculates their mean age to be 10 and the range to be 3.

The second group she calculates the mean age to be 10 and the range to be 7.

Explain the difference between the two groups of people.

4) Samuel has to decide which type of battery his company is to use in their toys.

He has a choice between two different batteries.

Type A has a median life of 15 hours with a range of 2 hours.

Type B has a median life of 15 hours with a range of 6 hours.

Which battery does Chris choose and why?

5) The manager of a shoe shop calculates the mean, median and mode of the man's shoe sizes she sells. These were the results.

Mode is 8, Mean is 7.5, Median is 7.

She has to buy some more stock. She can only order one size. Which size will it be?

Explain your answer.

6) A football team has 11 players. The mean weight is 95 kilograms and the range is 12kg. A player weighing 100kg is replaced by one weighing 90kg. What effect will this have on the range and mean? Explain why you say this.

7) A football team plays 20 matches. The mean number of goals scored is 1.5 and the mode is 2. In the 21st game they score 3 goals. What effect will this have on the mean and the mode? Explain your answer.

8) A class sits an examination. The paper is marked out of 40. Eve calculates the median mark to be 23 and the range to be 25. She later finds that one mark of 30 should be 15. What effect will this have on the median and the range?

129. Moving Averages

The table below shows the value of sales in a shop over a period of 20 days. The proprietor wants to keep track of the trend in her sales over a period of time so she calculates a simple 7 day moving average.

Day	Value of Sales	7 day moving average
1	£210.00	
2	£135.00	
3	£230.00	
4	£350.00	
5	£240.00	
6	£250.00	
7	£310.00	
8	£275.00	
9	£150.00	
10	£310.00	
11	£345.00	£268.57
12	£235.00	
13	£295.00	
14	£350.00	
15	£295.00	
16	£145.00	
17	£375.00	
18	£355.00	
19	£265.00	
20	£305.00	

- If sales on a Sunday are usually lower than other days, what day of the week is day 1?
- Explain why there can be no moving average for day 4.
- When can the first moving average be calculated?
- Complete the table of moving averages.
- By looking at the moving averages, what do you think the trend in sales is?

130. Frequency Polygons

Exercise 1

Construct a frequency polygon from each of the following sets of data

1) This table shows the heights of 20 tomato plants.

Height of tomato plant	89cm	90cm	91cm	92cm	93cm
Frequency	2	4	5	6	3

2) This table shows the number of goals scored per game in the English football league during one particular week.

Number of goals scored	0	1	2	3	4	5	6	7
Frequency	3	8	10	7	7	5	4	2

3) A milkman delivers milk to 400 houses on his morning round. The table shows the number of bottles the households take.

Number of bottles	1	2	3	4	5	6	7
Frequency	72	95	105	70	30	18	10

4) A firm makes egg timers, which are supposed to run for exactly 4 minutes. A sample of 100 were tested and the times they gave were as follows.

Time (secs)	236	237	238	239	240	241	242	243
Frequency	4	8	12	18	30	15	10	3

Exercise 2

Construct a frequency polygon from each of the following sets of grouped data.

In each case make a list of the mid value of each group first (as in question 1).

1) The scores of 200 students in an examination were as follows.

Mark	0-10	11-20	21-30	31-40	41-50	51-60	61-70	71-80	81-90	91-100
Frequency	2	7	9	21	53	67	25	8	6	2
Mid mark	5	15.5	25.5	35.5	45.5	55.5	65.5	75.5	85.5	95.5

2) This table shows the marks gained by 100 students in an examination.

Mark	0-10	11-20	21-30	31-40	41-50	51-60	61-70	71-80	81-90	91-100
Frequency	0	4	6	15	21	28	14	7	5	0

3) This table shows the heights of 100 college students in a class (to the nearest cm).

Height (cm)	141-145	146-150	151-155	156-160	161-165	166-170	171-175	176-180	181-185
Frequency	7	10	16	15	10	18	13	8	3

Why do you think that this polygon has two peaks?

4) This table shows the times at which 600 pupils arrived at school.

Time	8.10-8.20	8.20-8.30	8.30-8.40	8.40-8.50	8.50-9.00	9.00-9.10	9.10-9.20
Number	10	46	110	295	75	54	10

From the polygon decide at which time you think that school starts.

131. Cumulative Frequency 1

1) The table below shows the frequency distribution of the weekly wages for employees in a factory.

Wages (£w)	$0 < w \leq 80$	$80 < w \leq 100$	$100 < w \leq 130$	$130 < w \leq 150$	$150 < w \leq 180$
Frequency	7	15	41	20	7

a) Complete this cumulative frequency table.

Wage	£80	£100	£130		
Cumulative frequency	7	22			

b) Draw the cumulative frequency graph

c) From the graph estimate

- (i) the median wage
- (ii) the interquartile range
- (iii) the approximate number of employees who earn more than £120 per week.

2)

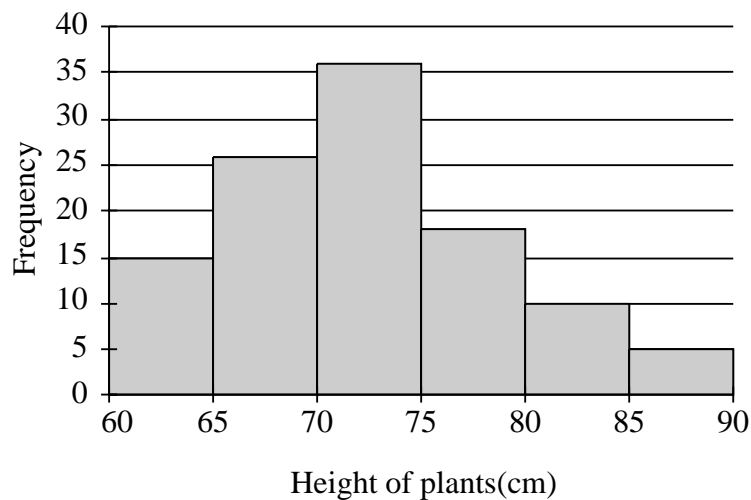

This diagram shows the heights of 110 plants.

a) Use the diagram to complete the table below.

	Frequency	Cumulative frequency
60 cm < height ≤ 65 cm	15	15
65 cm < height ≤ 70 cm	26	
70 cm < height ≤ 75 cm	36	
75 cm < height ≤ 80 cm		
80 cm < height ≤ 85 cm		
85 cm < height < 90 cm		

b) From the table above, draw the cumulative frequency diagram.

c) From the cumulative frequency diagram estimate (i) the median (ii) the number of plants whose height is less than 81 cms.

132. Cumulative Frequency 2

- 1) Nina carries out a survey of the speeds of vehicles passing a certain point on a motorway. Her results are shown in the table below.

Speed (mph)	Frequency	Cumulative frequency
$20 < \text{speed} \leq 30$	3	
$30 < \text{speed} \leq 40$	26	
$40 < \text{speed} \leq 50$	41	
$50 < \text{speed} \leq 60$	48	
$60 < \text{speed} \leq 70$	37	
$70 < \text{speed} \leq 80$	26	
$80 < \text{speed} \leq 90$	5	

- a) Copy and complete the table for the cumulative frequency.
 b) Draw the cumulative frequency graph.
 c) From the graph estimate (i) the median speed (ii) the approximate number of cars whose speed is below 75mph
- 2) Batteries are tested by using them in an electric toy and recording the length of time the toy operates before the battery fails. The results of 50 batteries are shown below

Time (t hours)	$9 < t \leq 11$	$11 < t \leq 13$	$13 < t \leq 15$	$15 < t \leq 17$	$17 < t \leq 19$
Frequency	4	10	19	14	3

- a) From the data draw a cumulative frequency graph.
 b) From the graph, estimate (i) the median life of a battery
 (ii) the interquartile range.
 If the battery company guarantee that their batteries last longer than 12 hours, approximately what percentage of their batteries don't meet this criteria?

- 3) The table below shows the runs scored by batsmen in a cricket team.

Runs scored	1 - 20	21 - 40	41 - 60	61 - 80	81 - 100
Frequency	10	22	36	14	2

- a) Complete this cumulative frequency table

Runs	20	40	60		
Cumulative frequency	10	32			

- b) Draw the cumulative frequency graph
 c) From the graph estimate (i) the median number of runs scored
 (ii) the number of times more than 70 was scored

133. Probability 1

1) Two dice are thrown together and their values added. Copy and complete the table below to show their sum

		Second dice					
		1	2	3	4	5	6
First dice	1	2	3	4	5		
	2	3	4	5			
	3	4	5				
	4	5					
	5						
	6						

2) Five cards have letters A, B, C, D and E on them.

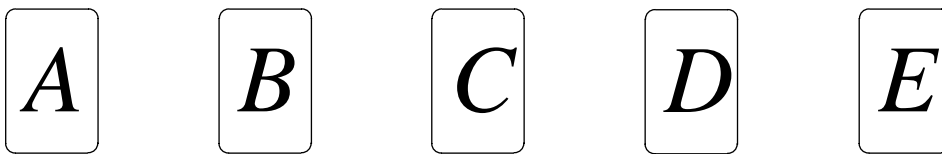

Two cards are taken at random and their letters recorded. Copy and complete this list of results (A,B) (A,C) (A,D) (A,E) (B,C)

3) The diagram shows two spinners, one numbered 1 to 4, the other 1 to 3. The outcome $1 + 2 = 3$ is shown. Make a table, as in question 1, to show all the possible outcomes.

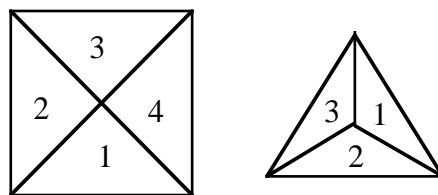

4)

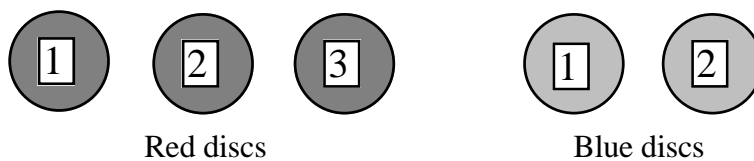

Three red discs are numbered 1 to 3, and two blue discs are numbered 1 and 2. A red disc is chosen at random followed by a blue disc. Complete the following list of all the possible outcomes. (1,1) (1,2) (2,1)...

5)

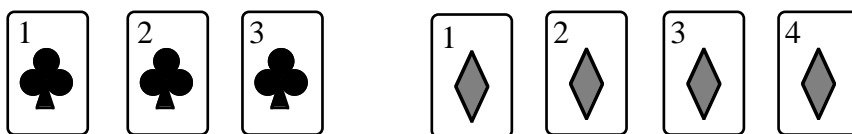

Three black cards are numbered 1 to 3 and 4 red cards are numbered 1 to 4. A black card is chosen at random followed by a red card. Complete this list of all the possible outcomes. (1,1) (1,2) (1,3) (1,4) (2,1)...

134. Probability 2

- 1) Two dice bearing the numbers 1,1,2,2,3,3 are thrown together and the numbers shown are added. Copy and complete the table below which shows the possible outcomes.

		Second Dice					
		1	1	2	2	3	3
First Dice	1	2	2	3	3		
	1	2	2	3			
	2	3	3				
	2	3					
	3						
	3						

What is the probability of getting a total of

- a) 6
 - b) more than 4
 - c) less than 4
- 2) Four cards have the numbers 1, 2, 3, 4 on them.

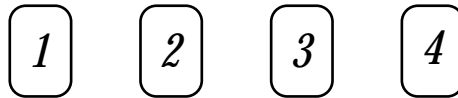

Two cards are taken at random and their sum recorded in this table. Copy and complete it.

	1	2	3	4
1		3		
2				
3				
4				

Use the table to find the probability of obtaining a sum

- a) of 7
 - b) greater than 4
- 3) The diagram shows two spinners, one numbered 1 to 4, the other having the letters A, B and C. The outcome is (1,B) is shown.
- a) Make a list of all the possible outcomes.
 - b) What is the probability of getting (2,A)?
 - c) What is the probability of getting a 4?

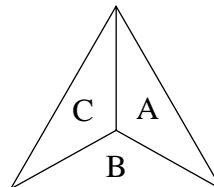
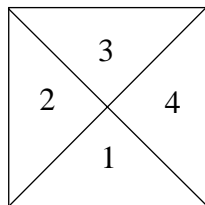

- 4) Three orange discs are numbered 1 to 3, and two green discs are numbered 1 and 2. An orange disc is chosen at random followed by a green disc.

List all the possible outcomes.

What is the probability of getting

- a) a 2 followed by a 1?
- b) a 1 and a 2 in any order
- c) a 3 and a 1 in any order?

135. Probability 3

1) Say whether each of the following events are likely, unlikely or have an even chance of happening

- Throwing a 1 on a dice.
- Throwing a 6 on a dice.
- Throwing an odd number on a dice.
- Drawing a green disc from a bag of 100 discs when the bag contains 70 green discs.

2) Three people, Alan, Betty and Cathy each buy raffle tickets. 100 tickets are sold altogether. Alan buys 5, Betty buys 10 and Cathy buys 20. Copy the following line and mark on it the chance of a) Alan winning b) Cathy winning c) Betty not winning.

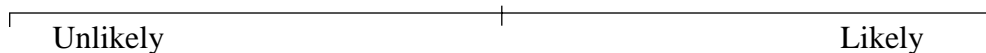

3) Copy the probability line.

There are 10 discs in a bag, 2 red, 5 blue and 3 green. A disc is drawn at random.

Show on the line the probability of getting (a) a red (b) a blue (c) a green (d) a red or blue.

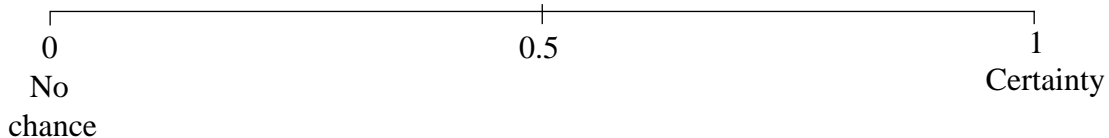

4) The probability of some events happening are given by these numbers.

0 0.1 0.3 0.5 0.7 0.9 1.0

The same events have the following chances of happening.

Likely, Even, Very unlikely, No chance, Very likely, Unlikely and Certain.

Match the number against each of these chances.

5) Another set of events have the following probability of happening.

19% 5% 100% 98% 67% 50% 0%

Match each of the numbers against each of the words in question 4.

6) A race horse won five times out of the last seven races. Is the chance of him winning the next race good, even or poor? Explain your answer.

7) Ann buys five raffle tickets. 1000 tickets are sold altogether. She wins a prize. She then says "buying five tickets in a raffle gives you a good chance of winning". Is this correct? Explain your answer.

8) Liam carries out a survey in the high street. After one hour he collects together his data and draws up this table.

Vehicle	Cars	Vans	Lorries	Buses	Other
Number	156	43	23	8	27

Do you think that the chance of the next vehicle being a car is good? Explain your answer.

9) Amy buys a CD player from a store. Because she spends more than £100 her name is entered into a prize draw. She says that the chance of a girl winning is 0.5 because there are the same number of girls in the world as boys. Is she correct? Explain your answer.

136. Probability 4

Find the probability of the events in question 1 to 6 happening.

- 1) Throwing a number 2 on a dice numbered 1 to 6.
- 2) Drawing a king from a pack of 52 playing cards (there are 4 kings in a pack)
- 3) Selection a girl at random from a class os 20 boys and15 girl.
- 4) Winning first prize in a raffle if you hold 10 tickets and 200 have been sold.
- 5) Picking an even number from the numbers 1 to 20.
- 6) Throwing an odd number on a dice numbered 1 to 6.
- 7) The order of play in a badminton competition is decided by drawing names from a hat. Six names, Holly, Sam, William, Sarah, Amy and Matthew are put into the hat and drawn at random. Find the probabilities of:
 - a) drawing Sarah's name first.
 - b) drawing a boy's name first.
 - c) not getting William's name first.
- 8) A bag contains 12 discs - 4 red, 5 green and 3 blue. A disc is taken out at random. What is the probability of drawing:
 - a) a green disc?
 - b) a red disc?
 - c) a disc which is not a blue disc?
- 9) In a raffle, 1000 tickets are sold. Emily buys 5 tickets.
 - a) What is her chance of winning?
 - b) The chance of David winning is 10%. How many tickets does he buy?

- 10) A biased spinner has the numbers 1, 2, 3 and 4 on it.

The probability of getting a 1 is 0.1, a 2 is 0.2 and a 3 is 0.2.

- a) What number are you most likely to get?
- b) If it is spun 100 times, how many two's would you expect to get?
- c) What is the probability of scoring a 6?

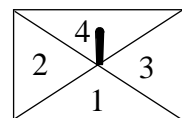

- 11) 10 cards have the numbers 1 to 10 on them.

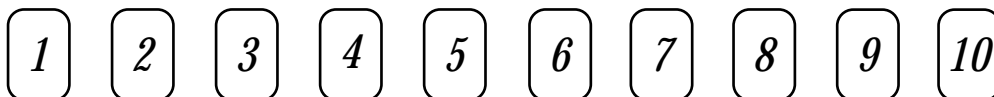

The cards are shuffled and placed face down on the table. A card is chosen at random.

Calculate the probability of each of the following:

- a) The card drawn will have the number 6 on it.
 - b) The number on the card will be greater than 6.
 - c) The number on the card will not be 6.
- 12) The probability of getting a 6 when rolling a dice is $\frac{1}{6}$. What is the probability of not getting a 6? explain your answer.

137. Probability 5

- 1) Two dice are thrown together and their values added. Copy and complete the table below to show their sums and find the probability that their sum is 8.

		Second Dice					
		1	2	3	4	5	6
First Dice	1	2	3	4	5		
	2	3	4	5			
	3	4	5				
	4	5					
	5						
	6						

- 2) Two dice bearing the numbers 1,1,2,2,3,3 are thrown together and the numbers shown are added. Copy and complete the table below which shows the possible outcomes.

		Second Dice					
		1	1	2	2	3	3
First Dice	1	2	2	3	3		
	1	2	2	3			
	2	3	3				
	2	3					
	3						
	3						

What is the probability of getting a total of

- a) 6
- b) more than 4
- c) less than 4

- 3) Five cards have the numbers 1, 2, 3, 4, 5 on them.

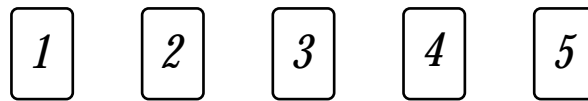

Two cards are taken at random and their sum recorded in this table. Copy and complete the table.

	1	2	3	4	5
1		3			
2					
3					
4					
5				9	

Use the table to find the probability of obtaining a sum

- a) of 8
- b) greater than 4

138. Tree diagrams

- 1) A bag contains 3 red counters and two blue counters.
 A counter is taken from the bag, its colour noted and replaced.
 This is done a second time.
 The tree diagram shows what happens.
- Copy and complete the diagram.
 - What is the probability of getting a red followed by a blue counter?
 - What is the probability of drawing two red counters?

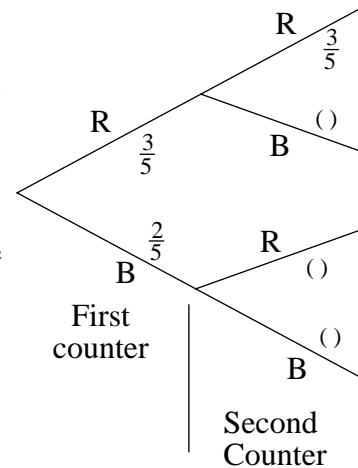

- 2) The probability that Dave will win the long jump final is 0.3 and the probability that he will win the 100 metres is 0.2. Draw a tree diagram to show this. From the diagram find
- the probability of him winning both
 - the probability of him winning neither
 - the probability of him winning one only.

- 3) A bag contains 3 blue and 2 white discs.
 A second bag contains 3 blue and 5 white discs.
 Complete the tree diagram and use it to find the probability of getting
- a blue followed by a white disc.
 - two blue discs.
 - two discs of the same colour.

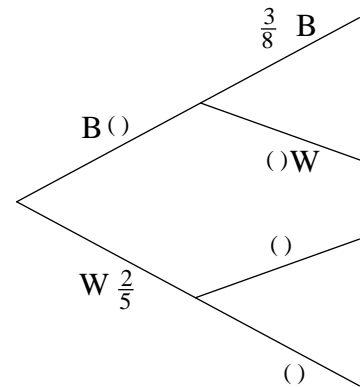

- 4) In form 11C there are 15 girls and 10 boys. In 11D there are 18 boys and 12 girls. Two people are to be chosen at random, one from each group.
 Show this on a tree diagram. From the diagram find the probability of choosing
- a boy and a girl
 - two boys
 - two girls
- 5) A bag contains 3 red sweets and 3 green sweets. A second bag contains 4 red sweets and 5 green sweets. A sweet is chosen at random from each bag in turn. Draw a tree diagram to represent this.
 From the diagram find the probability of taking
- a red followed by a green sweet
 - two sweets of the same colour
 - at least one red sweet

139. Relative Frequency 1

- 1) Two dice are thrown together and their values added. Copy and complete the table below to show their sums and find the probability that their sum is 6.

		Second Dice					
		1	2	3	4	5	6
First Dice	1	2	3	4	5		
	2	3	4	5			
	3	4	5				
	4	5					
	5						
	6						

If the dice are thrown 180 times, approximately how many times would you expect to get a total of 6?

- 2) A bag contains 5 discs with the numbers 1 to 5 on them. A second bag holds 6 discs, 3 red, 2 white and one green. A disc is taken at random from both bags, and then returned. Copy and complete this table of possible results.

		First bag				
		1	2	3	4	5
Second bag	R					
	R					
	R			R3		
	W					
	W	W1				
	G				G4	

- a) Use the table to find the probability of choosing
- a 2 followed by a white disc
 - a red disc
- b) If this procedure is carried out 100 times, how many times would you expect to choose
- a red disc?
 - a disc with a number 2 on it?
- 3) A drawing pin is thrown in the air and allowed to fall to the ground. It can either land point upwards or point down. The table shows the number of times it lands each way.

Number of throws	10	20	30	40	50
Number of times point up	3	8	14	19	26
Number of times point down	7	12	16	21	24

From the results

- suggest what you think the probability is of it landing point up?
 - explain why you would not make any assumptions after 10 throws.
 - calculate how many times you think it will fall point up when thrown 500 times.
- 4) Jenny does a survey of the people using her local newsagents over a period of 30 minutes. She counts 30 men and 50 women leaving the shop.
- What is the probability that the next person to leave the shop will be a man?
 - During the day 1000 people use the shop. Approximately how many will be women?

140. Relative Frequency 2

- 1) A dice has the numbers 1 to 6 on it. It is made so that five numbers have the same chance of occurring and the sixth has a greater chance.
 - a) Explain what you expect to happen if you throw it 50 times?
 - b) If the number 3 occurs 15 times, how many times do you expect each of the other numbers to occur?
 - c) The dice is thrown 500 times. The number 3 occurs 115 times. How many times do you expect the number 1 to occur?

- 2) A garden centre sells pots of white, red and yellow flowers. Over a period of 60 minutes it sells 25 white pots, 8 red pots and 17 yellow pots.
 - a) What is the probability that the next pot sold will contain red flowers?
 - b) Over the next four hours approximately how many pots would you expect to be sold?
 - c) How many of these pots would you expect to have red flowers?
 - d) The next day they sold 40 yellow pots over a period of 3 hours. Approximately how many of the other pots do you think they sold?

- 3) Yellow, blue and green discs are put into a bag. One disc is taken out of the bag at random, its colour noted then replaced. This is done 50 times. Yellow discs are taken out 28 times, blue 16 times and green 6 times
 - a) If there are a total of 20 discs in the bag, how many of each colour would you expect there to be?
 - b) If you carried out the experiment 1000 times, how many times would you expect to get a green disc?

- 4) The local school sells raffle tickets in aid of their funds. 350 are green, 750 yellow and 900 blue. They are all put into a box and taken out at random.
 - a) What is the probability that the first ticket is green?
9 winners had blue tickets.
 - b) Approximately how many winning tickets were green?
 - c) Approximately how many prizes were there altogether

- 5) A factory makes light bulbs. Bulbs are tested and then graded as excellent, good or poor. 40 bulbs are tested. One bulb is described as poor, three good and the rest excellent. Good and excellent bulbs are acceptable.
 - a) What is the probability that the next bulb will be acceptable?
During the day 5,000 bulbs are made.
 - b) Approximately how many are likely to be unacceptable?
The next day 145 bulbs were unacceptable.
 - c) Approximately how many bulbs were made altogether?

Answers

1. Rounding off and Estimating

Exercise 1

- 1) 70 2) 90 3) 140 4) 290 5) 700 6) 500
7) a. 850 b. 800 8) a. 370 b. 400 9) a. 2300
b. 2000 10) a. 5880 b. 5900 c. 6000

Exercise 2

- 1) a. 1000 b. $460 + 510 = 970$
2) a. 40, 20 b. 800 3) $200 + 300 = 500$
4) $60p + 50p + 80p = 190p$
5) $6 \times 20 = \text{£}120$ 6) $60 + 40 = 100$
7) $50 \times 3 = 150$ 8) $20 - 5 = 15$
9) $10 \times 40 = 400$

Exercise 3

- 1) $50 \times 30 = 1500$ 2) $30 \times 50 = 1500$
3) $10 \times 60 = 600$ 4) $50 \times 60 = 3000$
5) $90 \times 40 = 3600$ 6) $50 \times 30 = 1500$
7) $100 \times 40 = 4000$ 8) $200 \times 20 = 4000$
9) $40 \times 100 = 4000$ 10) $70 \times 200 = 14000$
11) $200 \div 20 = 10$ 12) $120 \div 20 = 6$
13) $160 \div 20 = 8$ 14) $240 \div 24 = 10$
15) $600 \div 30 = 20$ 16) $800 \div 20 = 40$
17) $1000 \div 50 = 20$ 18) $1600 \div 40 = 40$
19) $2000 \div 50 = 40$ 20) $2800 \div 70 = 40$
21) $\frac{30 \times 40}{6} = 200$ 22) $\frac{20 \times 40}{8} = 100$
23) $\frac{50 \times 60}{5} = 600$ 24) $\frac{30 \times 40}{20} = 60$
25) $\frac{300 \times 4}{30} = 40$ 26) $\frac{400 \times 20}{40} = 200$
27) $\frac{600 \times 30}{60} = 300$ 28) $\frac{300 \times 40}{60} = 200$

2. Estimation 1

Exercise 1

- 1) $20 + 60 = 80$ 2) $20 + 60 = 80$
3) $90 + 60 = 150$ 4) $60 + 80 = 140$
5) $40 - 20 = 20$ 6) $60 - 30 = 30$
7) $80 - 40 = 40$ 8) $85 - 35 = 50$
9) $70 + 30 = 100$ 10) $20 + 50 = 70$
11) $90 + 60 = 150$ 12) $40 + 70 = 110$
13) $90 - 30 = 60$ 14) $70 - 30 = 40$
15) $110 - 70 = 40$ 16) $140 - 80 = 60$

Exercise 2

- 1) $80 \times 20 = 1600$ 2) $40 \times 20 = 800$
3) $60 \times 30 = 1800$ 4) $80 \times 30 = 2400$
5) $100 \times 20 = 2000$ 6) $50 \times 30 = 1500$
7) $140 \times 20 = 2800$ 8) $80 \times 40 = 3200$
9) $100 \times 60 = 6,000$ 10) $170 \times 10 = 1700$
11) $250 \times 10 = 2500$ 12) $400 \times 30 = 12,000$
13) $500 \times 40 = 20,000$ 14) $600 \times 50 = 30,000$
15) $700 \times 50 = 35,000$

Exercise 3

- 1) $4 \times 6 = 24$ 2) $5 \times 5 = 25$
3) $8 \times 8 = 64$ 4) $6 \times 10 = 60$

- 5) $4 \times 20 = 80$ 6) $7 \times 20 = 140$
7) $5 \times 30 = 150$ 8) $4 \times 40 = 160$
9) $8 \times 50 = 400$ 10) $6 \times 30 = 180$
11) $9 \times 50 = 450$ 12) $6 \times 70 = 420$
13) $8 \times 40 = 320$ 14) $4 \times 60 = 240$
15) $7 \times 80 = 560$

Exercise 4

- 1) $4 \times 3 = 12$ 2) $5 \times 8 = 40$
3) $9 \times 6 = 54$ 4) $5 \times 5 = 25$
5) $7 \times 4 = 28$ 6) $4 \times 5 = 20$
7) $8 \times 8 = 64$ 8) $10 \times 6 = 60$
9) $6 \times 3 = 18$ 10) $8 \times 8 = 64$
11) $5 \times 10 = 50$ 12) $8 \times 10 = 80$
13) $2 \times 20 = 40$ 14) $9 \times 20 = 180$
15) $4 \times 20 = 80$

Exercise 5

- 1) $30 \div 5 = 6$ 2) $40 \div 8 = 5$
3) $60 \div 10 = 6$ 4) $100 \div 20 = 5$
5) $70 \div 10 = 7$ 6) $90 \div 9 = 10$
7) $60 \div 30 = 2$ 8) $90 \div 30 = 3$
9) $60 \div 15 = 4$ 10) $40 \div 10 = 4$
11) $90 \div 30 = 3$ 12) $120 \div 40 = 3$
13) $140 \div 7 = 20$ 14) $200 \div 40 = 5$
15) $300 \div 50 = 6$ 16) $100 \div 10 = 10$
17) $400 \div 80 = 5$ 18) $500 \div 20 = 25$

Exercise 6

- 1) $80 \div 20 = 4$ 2) $60 \div 10 = 6$
3) $90 \div 9 = 10$ 4) $50 \div 6 = 10(\text{approx})$
5) $40 \div 4 = 10$ 6) $60 \div 10 = 6$
7) $90 \div 15 = 6$ 8) $50 \div 5 = 10$
9) $40 \div 20 = 2$ 10) $70 \div 14 = 5$
11) $30 \div 6 = 5$ 12) $150 \div 15 = 10$
13) $40 \div 40 = 1$ 14) $300 \div 35 = 10(\text{approx})$
15) $240 \div 90 = 3(\text{approx})$ 16) $800 \div 40 = 20$

3. Estimation 2

Exercise 1

- 1) 1800 2) 2100 3) 2500 4) 4000 5) 3200
6) 3000 7) 6300 8) 5000 9) 16000
10) 18000 11) 20000 12) 40000 13) 120000
14) 450000 15) 160000 16) 100000
17) 120000 18) 50000 19) 60000 20) 150000

Exercise 2

- 1) 18 2) 600 3) 1200 4) 0.8 5) 0.06
6) 0.00004 7) 29 8) 13 9) 11 10) 8.3
11) 0.4 12) 3 13) 10 14) 4 15) 4
16) 5 17) 0.2 18) 40 19) 0.5 20) 0.25
21) 0.3 22) 200 23) 5 24) 400 25) 400
26) 90 27) 12 28) 12 29) 100,000

4. Reading and Writing Whole Numbers

Exercise 1

- 1) One hundred and six
2) Two hundred and fourteen
3) Three hundred and fifty six

- 4) Five hundred and ninety seven
- 5) Eight hundred and ninety three
- 6) One thousand three hundred and forty two
- 7) Four thousand three hundred and twenty seven
- 8) Five thousand three hundred and two
- 9) Seven thousand one hundred and two
- 10) Eight thousand and seventy three
- 11) Eleven thousand three hundred and forty five
- 12) Fourteen thousand five hundred and thirty six
- 13) Twenty seven thousand three hundred and fifty six
- 14) Fifty four thousand three hundred and sixty two
- 15) Seventy three thousand and two
- 16) One hundred and sixty three thousand seven hundred and sixty five
- 17) Three hundred and seventy four thousand three hundred and five
- 18) Three hundred and forty thousand
- 19) Five hundred and forty three thousand and nine
- 20) Six hundred thousand and eighty seven
- 21) Six million
- 22) Four million seven hundred and sixty two thousand eight hundred
- 23) Five million seven hundred thousand three hundred and forty five
- 24) Four million seven hundred and sixty four
- 25) Seven million one hundred thousand and sixty seven

Exercise 2

- 1) 156 2) 706 3) 407 4) 670 5) 3000
- 6) 4367 7) 2080 8) 6006 9) 5067 10) 9990
- 11) 27,000 12) 40,000 13) 63,005
- 14) 87,500 15) 77,422 16) 18,957
- 17) 200,000 18) 167,000 19) 324,556
- 20) 754,072 21) 3,000,000 22) 4,900,000
- 23) 7,116,956 24) 6,014,957 25) 8,753,002

Exercise 3

- 1) 1683 2) 1090 3) 231 4) 76 5) 51
- 6) 141 7) 856 8) 2239 9) 79 10) 248

Exercise 4

- 1) Fifty 2) Seven hundred 3) Three thousand
- 4) Two 5) Ten thousand 6) Six thousand
- 7) Ninety thousand 8) Three million
- 9) Eight hundred thousand
- 10) Seventy thousand

5. Multiplying and Dividing by 10,100 etc

Exercise 1

- 1) 60 2) 170 3) 360 4) 1240 5) 6740
- 6) 400 7) 2,500 8) 14,200 9) 36,200
- 10) 76,000 11) 7000 12) 38,000
- 13) 97,000 14) 270,000 15) 380,000
- 16) 4,200,000 17) 7 18) 40 19) 92
- 20) 210 21) 3 22) 40 23) 82
- 24) 100 25) 6 26) 16 27) 20 28) 37

Exercise 2

- 1) 13 2) 74 3) 122 4) 276 5) 28.7
- 6) 53.8 7) 726.4 8) 1236.7 9) 347

- 10) 750 11) 1648 12) 12837 13) 460
- 14) 1850 15) 17360 16) 87240
- 17) 2532 18) 12,673 19) 2460
- 20) 341,400 21) 3 22) 4.56 23) 0.2
- 24) 0.074 25) 50 26) 19 27) 93.7
- 28) 0.2 29) 23 30) 370 31) 400 32) 53.2

Exercise 3

- 1) 0.2 2) 0.27 3) 1.7 4) 15.3 5) 0.634
- 6) 0.034 7) 0.0056 8) 0.0002 9) 0.0243
- 10) 0.484 11) 3.27 12) 18.7 13) 0.00367
- 14) 0.0067 15) 0.000183 16) 0.005
- 17) 0.006 18) 0.016 19) 0.0026
- 20) 0.02745 21) 0.0003765 22) 0.0000254
- 23) 0.000034 24) 0.00003

Exercise 4

- 1) 100 2) 1000 3) 1000 4) 100 5) 1000
- 6) 100 7) 2000 8) 80 9) 0.03 10) 0.0007

6. Multiplication and Division

Exercise 1

- 1) 13 2) 13 3) 20r2 4) 40r1 5) 23r5 6) 40r3
- 7) 24 8) 83 9) 54 10) 87 11) 42r2 12) 119

Exercise 2

- 1) 6r12 2) 7 3) 7r2 4) 5r2 5) 9 6) 12 7) 16r21
- 8) 7r6 9) 13r7 10) 11 11) 6r33 12) 15 13) 9r24
- 14) 22 15) 16 16) 11r14 17) 16r9 18) 13 19) 27
- 18) 28r23

Exercise 3

- 1) 5.5 2) 7.5 3) 11.4 4) 5.5 5) 20.5 6) 9.25
- 7) 15.25 8) 21.2 9) 16.5 10) 36.25 11) 17.4
- 12) 33.5 13) 25.5 14) 64.5 15) 62.5 16) 113.5
- 17) 34.425 18) 9.2 19) 3.9 20) 85.75

Exercise 4

- 1) 374 2) 615 3) 682 4) 945 5) 2016 6) 3478
- 7) 2057 8) 4437 9) 8478 10) 3686 11) 11,934
- 12) 29,502 13) 27,051 14) 24,956 15) 8732
- 16) 47,628 17) 16,695 18) 14,654 19) 17,199
- 20) 29,346

7. Ordering Directed Numbers

Exercise 1

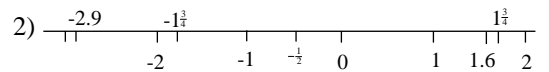
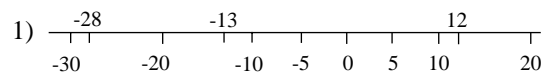

- 3) -13, -12, -6, -1, 0, 1, 5, 26

- 4) -6, $-4\frac{1}{4}$, -1.3, $-\frac{1}{2}$, 0, 1.8, 2, 3.1.

Exercise 2

- 1) 14 2) 2 3) -3 4) 2 5) -13
- 6) 5 7) -20 8) -2 9) -4 10) -11

Exercise 3

- 1) 4 2) 6 3) 9 4) 9 5) 3
- 6) 7 7) 3 8) 9 9) 8 10) 5

Exercise 4

- 1) a) Belfast b) Perth c) Perth 10°C

- d) Belfast 3°C 2) 12°C 3) 12°C
 4) A gets 4, B gets 4, C gets 6 so C wins.

8. Use of the Calculator 1

Exercise 1

- 1) 6,3 2) 23,32 3) 12,48 4) 27,12
 5) 8,2 6) 7,4 7) 26,36

Exercise 2

- 1) 0.2 2) 26.0 3) 55.1 4) 3.5
 5) 2.4 6) 5.7 7) 18.0 8) 30.8
 9) 49.2 10) 22.3 11) 40.4
 12) 21.5 1) 13) 2.3 14) 16.9
 15) 1.4 16) 1.8 17) 20.8
 18) 0.9 19) 3.9 20) 12.4
 21) 6.3 22) 13.2 23) 32.0
 24) 11.3 25) 7.4 26) 44.8
 27) 8.1

Exercise 3

- 1) 0.85 2) 0.25 3) 1.27 4) 0.68 5) 1.09
 6) 0.58 7) 0.04 8) 0.07 9) 1.05 10) 0.08
 11) 0.05 12) 0.06 13) 0.06 14) 0.23 15) 5.92
 16) 7.31 17) 6.87 18) 9.05 19) 8.09 20) 1.5
 21) 0.90 22) 1.89 23) 1.84 24) 2.21

9. Use of the Calculator 2

Exercise 1

- 1) 5 and 3 2) 17 and 25 3) -12 and 48 4) 19 and 4
 5) 9 and 2 6) 3 and 7 7) 19 and 27

Exercise 2

- 1) 4.175 2) -2.12 3) 4.68 4) 24.25 5) 4.08 6) 8
 7) 0.8692 8) 2 9) -0.4575 10) 9.216 11) 0.1320
 12) 3.156 13) 0.3771 14) 0.1584 15) 34.23
 16) 17.57 17) 2.567 18) 2.826 19) 0.3598
 20) 0.07387 21) 3.838 22) 0.2586 23) 0.1347
 24) 24.31

10. Types of Numbers

Exercise 1

- 1) 25 2) 7 3) 47 4) 45 5) 2
 6) 1, 2, 3, 4, 6, 8, 12, 16, 24, 48
 7) 1, 8, 27 8) 4 or 16 or 36 9) 24 or 4
 10) 4, 9, 25, or 49

Exercise 2

- 1) Factors 2) Square 3) Multiples 4) Square
 5) Even, Prime 6) Prime 7) Square, Cube
 8) Square root, Cube root 9) Factors 10) Not

Exercise 3

- 1) 8 2) 16 3) 125 4) 17 5) 3 6) 90
 7) 54 8) 2 9) 4 10) 5 11) 61 12) 109

Exercise 4

- 1) 21 cannot be divided exactly by 5
 2) 27 cannot be divided exactly by 17
 3) 44 is divisible by other numbers.
 4) No whole number can be multiplied by itself to get 60.
 5) Means $5 \times 5 \times 5$ not 5×3 .
 6) 9×9 is not equal to 39

- 7) 41, 43 and 47 are prime
 8) 9 has 3 factors, 1, 3 and 9. A prime number has only 2 factors.
 9) 1 divides into 100 exactly so it is a factor.
 10) 2 is even and prime.

11. Standard Form

Exercise 1

- 1) 3.6×10^1 2) 4.26×10^2 3) 8.3×10^3
 4) 9.4×10^4 5) 5.62×10^5 6) 1.5×10^{-1}
 7) 3.14×10^{-2} 8) 5.4×10^{-3} 9) 2.3×10^{-4}
 10) 1.5×10^{-5} 11) 1.43×10^{-3} 12) 1.573×10^2
 13) 1300 14) 34,000 15) 148,000
 16) 21,000,000 17) 34,100 18) 4,320,000
 19) 218,000 20) 0.00936 21) 0.0000421
 22) 0.000597 23) 0.00000326 24) 0.0000485

Exercise 2

- 1) 7.5×10^6 2) 1.288×10^9 3) 1.272×10^{-6}
 4) 2.368×10^{-11} 5) 1.512×10^3 6) 1.828×10^5
 7) 2.0×10^5 8) 1.766×10^8 9) 1.906×10^2
 10) 6.604×10^0 11) 1.267×10^3 12) 2.039×10^3
 13) 1.315×10^7 14) 3.529×10^{-22}

Exercise 3

- 1) 6×10^{10} , 5×10^5 2) 9×10^{-8} , 6×10^{-4}
 3) 2.1×10^{-7} 4) 1:81.31 5) 1.281secs
 6) 1:0.0005438 7) a. 9.461×10^{12} km
 b. 8.313 years

12. Prime Factors

Exercise 1

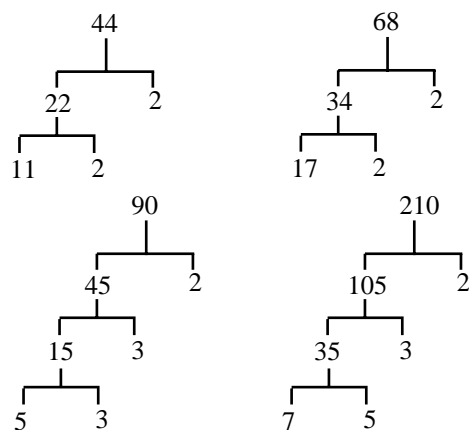

Exercise 2

- 1) 1,3,5,15 2) 1,2,4,5,10,20
 3) 1,2,3,4,6,8,12,24 4) 1,2,3,5,6,10,15,30
 5) 1,2,4,8,16,32 6) 1,2,4,5,8,10,20,40
 7) 1,3,5,9,15,45
 8) 1,2,3,4,5,6,10,12,15,20,30,60 9) 1,71
 10) 1,2,3,4,6,7,12,14,21,28,42,84
 11) 1,2,3,5,6,9,10,15,18,30,45,90
 12) 1,2,4,5,10,20,25,50,100
 13) 1, 2, 3, 4, 5, 6, 8, 10, 12, 15, 20, 24, 30, 40, 60, 120
 14) 1, 2, 5, 10, 13, 26, 65, 130
 15) 1, 2, 3, 5, 6, 10, 15, 25, 30, 50, 75, 150

Exercise 3

- 1) $2 \times 3 \times 5^2$ 2) $2^5 \times 5$ 3) $2^3 \times 5^2$
 4) $2 \times 3 \times 5 \times 7$ 5) $2^2 \times 5 \times 13$
 6) $3^3 \times 5^2$ 7) $3^3 \times 5 \times 7$ 8) 5×7^3
 9) $3 \times 5 \times 7 \times 11$ 10) $3^2 \times 5 \times 23$
 11) $2^4 \times 3 \times 5 \times 7$ 12) $2^2 \times 3^3 \times 13$
 13) $2^2 \times 3^2 \times 5 \times 7$ 14) $2^3 \times 3^3 \times 11$
 15) $2^2 \times 5 \times 7 \times 11$

Exercise 4

- 1) $2^2 \times 3, 3$ 2) $2 \times 3^2, 2$ 3) $2^2 \times 3^2 \times 5, 5$
 4) $2^4 \times 5, 5$ 5) $2 \times 3^4, 2$ 6) $2^2 \times 3^2 \times 7, 7$
 7) $7^3, 7$ 8) $2^2 \times 3^2 \times 13, 13$ 9) $2^5 \times 19, 38$
 10) $2^2 \times 5 \times 7^2, 5$ 11) $2^3 \times 3 \times 5^2, 6$
 12) $2^3 \times 3^2 \times 5, 10$
 13) $2^2 \times 3 \times 5^2, 3$ 14) $2^6 \times 3, 3$
 15) $2 \times 5^2 \times 37, 54$

Exercise 5

- 1) 27 2) 45 3) 25 4) 271 5) 147 6) 63
 7) 147 8) 45 9) 195 10) 117 11) 39 12) 75
 13) 135 14) 315 15) 245

13. Recurring Decimals

- 1) a) $0.\dot{5}$ b) $0.\dot{8}$ c) $0.\dot{2}$ d) $0.\dot{7}$ e) $0.4\dot{3}$ f) $0.2\dot{7}$
 g) $0.3\dot{6}$ h) $0.5\dot{1}$ i) $0.1\dot{2}2$ j) $0.5\dot{4}2$ k) $0.4\dot{1}8$
 l) $0.0\dot{7}4$
 2) a, b, c, f, g, h, i, m, n
 3) - Five fractions of each type-
 4) a) $10x = 2.3\dot{4}2$ b) $100x = 23.4\dot{2}3$
 c) $1000x = 234.2\dot{3}4$ d) $999x = 234$
 e) $x = \frac{234}{999}$ or $\frac{26}{111}$
 5) a) $\frac{13}{99}$ b) $\frac{1}{33}$ c) $\frac{20}{99}$ d) $\frac{9}{11}$ e) $\frac{5}{99}$ f) $\frac{50}{99}$
 g) $\frac{61}{99}$ h) $\frac{11}{999}$ i) $\frac{14}{27}$ j) $\frac{1}{111}$

14. Fractions, Decimals and Percentages 1**Exercise 1**

- 1) 0.75 2) 0.625 3) 0.4 4) 0.375 5) 0.4167
 6) 0.35 7) 0.5333 8) 0.28 9) 0.2308
 10) 0.1481 11) 0.56 12) 0.2667 13) 0.55
 14) 0.4286 15) 0.5556 16) 0.4375
 17) 0.3478 18) 0.5625

Exercise 2

- 1) 26% 2) 34% 3) 72% 4) 87% 5) 64%
 6) 35% 7) 42% 8) 96.1% 9) 43.2%
 10) 61.4% 11) 58.4% 12) 82.6% 13) 93.2%
 14) 30% 15) 60% 16) 190% 17) 238%
 18) 641%

Exercise 3

- 1) 80% 2) 80% 3) 46.67% 4) 15%
 5) 56.25% 6) 35.71% 7) 43.48% 8) 48%
 9) 51.43% 10) 32.43% 11) 62.5%
 12) 46.88% 13) 69.23% 14) 79.41%
 15) 86.17% 16) 73.21% 17) 51.92%
 18) 58.38%

Exercise 4

- 1) 0.2, 23%, $\frac{1}{4}$ 2) 36%, $\frac{3}{8}$, 0.4
 3) 0.8, 87%, $\frac{7}{8}$ 4) 0.3, 31%, $\frac{5}{16}$
 5) 10%, 0.14, $\frac{3}{20}$ 6) 43.7%, $\frac{7}{16}$, 0.47
 7) 30%, $\frac{8}{23}$, 0.35 8) 0.47, 47.3%, $\frac{9}{17}$
 9) 0.2, 21%, $\frac{6}{28}$ 10) 0.25, 25.6%, $\frac{8}{31}$

Exercise 5

- 1) $\frac{0}{\quad} \frac{b}{\quad} \frac{c}{\quad} \frac{a}{\quad} \frac{1}{\quad}$
 2) $\frac{0}{\quad} \frac{b}{\quad} \frac{a}{\quad} \frac{c}{\quad} \frac{1}{\quad}$
 3) $\frac{0}{\quad} \frac{b}{\quad} \frac{a}{\quad} \frac{c}{\quad} \frac{1}{\quad}$

15. Fractions, Decimals and Percentages 2**Exercise 1**

- 1) $\frac{1}{4}$ 2) $\frac{2}{5}$ 3) $\frac{3}{10}$ 4) $\frac{1}{5}$ or $\frac{4}{20}$ 5) $\frac{5}{9}$
 6) 60% 7) 30% 8) 25% 9) 50% 10) 35%

Exercise 2

- 1) 15 2) 153 3) £78.75 4) £1.05 5) 12.5m
 6) 9.375m 7) £31.25 8) 36.75m 9) £15.40
 10) 2.475m 11) £38.50 12) 2.31 metres

Exercise 3

- 1) 222 2) 12 3) 342 4) 205 5) 90p
 6) 60p 7) £11.40 8) 1.36 metres
 9) £2.16 10) £3.24 11) £8.58 12) 1116

Exercise 4

- 1) 48% 2) 63% 3) 68% 4) 46% 5) 62%
 6) 65% 7) 22% 8) 90% 9) 70% 10) 62%
 11) 85% 12) 69% 13) 57% 14) 61%
 15) 91% 16) 60%

Exercise 5

- 1) $\frac{60}{200}$ or $\frac{3}{10}$ 2) $\frac{450}{800}$ or $\frac{45}{80}$ or $\frac{9}{16}$
 3) $\frac{3}{10}$, 30% 4) £100 5) £30

16. Fractions, Decimals and Percentages 3

- 1) £132 2) £144 3) £55,800 4) 45 miles
 5) 33 tonnes 6) 207 7) 37,500 8) 100
 9) 59,360 10) 120 11) £63.60 12) £47
 13) 320g 14) £8.40 15) £851.88
 16) 25.5 cm 17) £29.38

17. Fractions, Decimals and Percentages 4**Exercise 1**

- 1) £117 2) £242 3) £180 4) £2,300
 5) £5,544 6) £185 7) £52.50 8) £41,650
 9) £58.40 10) £351

Exercise 2

- 1) 20% 2) 60% 3) 33% 4) 20% 5) 11%

- 6) 13% 7) 4% 8) 6% 9) 6% 10) 24%

Exercise 3

- 1) £4 2) £36 3) £135 4) £400 5) £315
6) £240 7) £1040 8) £16.80 9) £132
10) £504

18. Interest

Exercise 1

- 1) £60 and £62.43 2) £45 and £47.75
3) £120 and £126 4) £360 and £389.57
5) £200 and £204 6) £1050 and £1183.79
7) 888 and 928.77 8) 300.60 and 309.71
9) 1300 and 1400.79 10) £240 and £259.98

Exercise 2

- 1) a) £3582.16 b) £4053.28 c) £19,100.65
2) a) 1.051 b) 10,510 11,046.01 11,609.36
12,201.43 12,823.71 13,477.72
3) 12,767.49 4) £924.52

19. Ratio and Proportion

Exercise 1

- 1) 400 : 500 2) 300 : 700 3) 75 : 125
4) 280 : 320 5) 500 : 700 6) 525 : 225
7) 250 : 550 8) 250 : 450 9) 245 : 385
10) 495 : 770 11) 840 : 1365 12) 520 : 650
13) 70 : 30 : 20 14) 125 : 150 : 175
15) 125 : 200 : 225 16) £1.98 : £4.62 : £7.26

Exercise 2

- 1) £360 : £240 2) 30 metres, 70 metres
3) 4 4) a) 75g, 225ml, 90g, 9, 255g
b) 187.5g, 562.5ml, 225g, 22.5eggs, 637.5g
5) a) £160 b) £360 6) 494 : 456 7) 160
8) 7 9) 175g, 75g, 300g 10) 480, 200, 120.
11) £12,000, £8,000, £4,000

20. Personal and Household Finance

- 1) 8 for £1.12 2) a) £3.17 b) £1.83
3) 19 stamps, 6p left over 4) a) £6.20 b) £3.80
5) £124.40 6) 11 weeks 7) £3.50
8) £949.85 9) 10 with 10p over
10) £101.43 11) £212.40 12) £1.96
13) £5.90, £4.10 14) 14.9
15) 92, £37.72, £45.84 16) £65.40
17) £2.90 18) 7 19) £8.40

21. Tables

- 1) a) 0837 b) 0952 c) 22 minutes d) 1708
2) a) £1119 b) £1618 c) £3356
3) a) 30 minutes b) 1 hour 40 minutes c) yes
4) a) 381 b) 281 c)) Glasgow and Edinburgh or
Swansea and Cardiff

22. Conversion Graphs 1

- 1) a) 8 dollars b) 6.90 c) 1.44 dollars
2) a) 2500 yen b) £7.20 c) 210 yen

23. Conversion Graphs 2

- 1) 254cm a) 193cm b) 39 inches 2) 160km a) 144km

- b) 50 miles 3) a) 44 dollars b) £22 4) a) 45,550 litres
b) 10,975 gallons

24. Distance Time Diagrams 1

- 1) a) 12km b) 16mins c) 21km/hr d) 17.6km/hr
2) a) B b) 42mins c) 36mins d) 30mins e) A
3) 80km b) 26mins c) 164km/hr d) 28mins

25. Distance Time Diagrams 2

- a) 12 minutes b) 8km/hr c) 2 hours d) 6.25km/hour
e) 42 minutes f) 14:06 g) the very first part: the graph
is steepest i) second jogger j) 13:54 k) 12 minutes

26. Trial and Improvement 1

- 1) 3 cows 4 sheep 2) 3 tables 12 chairs
3) 3 at 26p, 2 at 20p 4) 10 at 30p, 7 at 25p
5) 4 pencils, 7 pens 6) 7 pencils, 9 pens
7) 8 of 4 and 5 of 6 8) 7 of 5 and 4 of 12
9) 8.3 cm 10) 9.2 cm 11) 6.1 cms
12) 7.8 cms

27 Trial and Improvement 2

Exercise 1

- 1) 3.4 2) 3.8 3) 4.4 4) 4.6 5) 5.1
6) 4.3 7) 3.9 8) 4.9 9) 5.2

Exercise 2

- 1) 4.3 2) 5.6 3) 7.2 4) 9.3 5) 3.5
6) 3.7 7) 7.5 8) 9.8 9) 4.0 10) 3.6
11) 4.1 12) 4.9 13) 5.5 14) 4.7 15) 4.7
16) 3.7 17) 5.7 18) 3.6 19) 11.3 20) 5.0

28. Number Patterns and Sequences 1

Exercise 1

- 1) 12, 14 2) 15, 17 3) 22, 25 4) 25, 29
5) 28, 33 6) 48, 57 7) 18, 24 8) 15, 20
9) 35, 47 10) 17, 23 11) 35, 41 12) 23,30
13) 5, 3 14) 10, 5 15) 7, 4 16) -5, -12
17) -3, -5 18) -2, -7 19) -20, -28
20) -16, -22 21) 13, 16

Exercise 2

- 1) a) 22 b) add on 7 2) a) 27 b) add on 8
3) a) 16 b) add on 6 4) a) 13 b) add previous
two numbers together
5) a) 128 b) double previous number
6) a) 19 b) add on 3 7) a) 127 b) double the
previous number and add 1.
8) a) 729 b) multiply previous number by 3
9) a) 2 b) half previous number

Exercise 3

- 1) a) 11, 13 b) add 2 to the previous number
c) $2n - 1$
2) a) 17, 20 b) add 3 to the previous number
c) $3n - 1$
3) a) 25, 29 b) add 4 to the previous number
c) $4n + 1$
4) a) 36, 42 b) add 6 to the previous number
c) $6n$
5) a) 37, 43 b) add 6 to the previous number

- c) $6n + 1$
 6) a) 37, 42 b) add 5 to the previous number
 c) $5n + 7$
 7) a) 13, 15 b) add 2 to the previous number
 c) $2n + 1$
 8) a) 18, 21 b) add 3 to the previous number
 c) $3n - 3$
 9) a) 36, 41 b) add 5 to the previous number
 c) $5n + 6$

Exercise 4

- 1) a) 8 b) add 2 and 1 alternately c) add 1 and 2 alternately
 2) a) 20 b) 24 c) $4(n + 1)$ or $4n + 4$
 d) $4(21) = 84$

29. Number Patterns and Sequences 2

- 1) a) 9 b) 11 c) $2n - 1$ d) 79
 2) a) 20 b) 30 c) 12
 3) a) 15 b) 20 c) $5n - 5$ or $5(n - 1)$ d) 45
 4) a) 22 b) 27 c) $5n + 2, 62$

30 Indices

Exercise 1

- 1) 4 2) 8 3) 64 4) 125 5) 49 6) 512 7) 625

Exercise 2

- 1) 100 2) 1000 3) 10,000 4) 100,000 5) 1728
 6) 169 7) 160,000

Exercise 3

- 1) $2^4, 16$ 2) $2^6, 64$ 3) $2^9, 512$ 4) $3^4, 81$ 5) $4^9, 262,144$
 6) $2^8, 256$ 7) $3^6, 729$ 8) $4^{10}, 1,048, 576$
 9) $5^8, 390, 625$ 10) $7^7, 823,543$ 11) a^5 12) b^7
 13) c^{11} 14) x^{10} 15) y^{17}

Exercise 4

- 1) 2^2 2) 4^2 3) 5^2 4) 6^4 5) 7^3 6) 9^3 7) 2^2 8) 4^3
 9) 7^5 10) 6^4 11) 10^5 12) 5^7 13) 8^{15} 14) x^4
 15) y^3 16) z^3 17) x^4 18) y^5 19) z^2 20) a^8

Exercise 5

- 1) 2^6 2) 3^{20} 3) 5^{28} 4) 7^{26} 5) 12^{40} 6) 15^{40} 7) a^{20}
 8) b^{25} 9) c^{12} 10) x^{24} 11) y^{63} 12) z^{24}

Exercise 6

- 1) 512 2) 59, 049 3) 1000 4) 20,736 5) 759,375
 6) 2744 7) 144 8) 194, 481 9) 256 10) 8000

Exercise 7

- 1) $3a^{11}$ 2) $2b^9$ 3) $6x^{15}$ 4) $30y^7$ 5) $3x^4$ 6) $2y^3$
 7) $2z^3$ 8) $5z^3$ 9) $2x^4$ 10) $3y^5$ 11) $4z^2$ 12) $4a^8$
 13) $6b^7$ 14) $4a^8$ 15) $27b^6$ 16) $16c^6$ 17) $27x^9$
 18) $16y^{12}$

31. Number Machines

- 1) a) 20 b) 15 c) 7 d) 7 e) 6
 f) 7 g) 16 h) 6 i) 63 j) 10
 2) a) (i) 13 (ii) 38 (iii) -17
 b) (i) 17 (ii) 52 (iii) -11
 c) (i) 8 (ii) 11 (iii) 5
 d) (i) -3 (ii) 1 (iii) -8
 3) a) $3n + 7$ b) $5n + 4$ c) $8n - 3$
 d) $\frac{n}{6} + 9$ e) $\frac{n}{2} - 7$

32. Substitution 1

Exercise 1

- 1) a) £26.40 b) £21.45 2) a) £64.30 b) £100.30
 3) a) £10 b) £19, 4 days 4) a) 88 minutes
 b) 71 minutes

Exercise 2

- 1) 7 2) 8 3) 9 4) 1 5) 1 6) 2 7) -1
 8) -2 9) -1 10) 2 11) 10 12) 18
 13) 2 14) -1 15) -8 16) 30 17) 14
 18) 6 19) -6 20) -3 21) 7

Exercise 3

- 1) -1 2) 1 3) -2 4) -3 5) 7 6) -4
 7) -1 8) 2 9) -11 10) 2 11) 2 12) 5
 13) -6 14) 2 15) -12 16) 0 17) 0 18) -10
 19) -8 20) -27 21) 2

Exercise 4

- 1) 18 2) 3 3) 12 4) 27 5) 28 6) 15
 7) 10 8) 14 9) 12 10) 40 11) 40 12) -5

33. Substitution 2

- 1) 25 2) 11 3) -6 4) -3 5) 4 6) 7
 7) -3 8) -13 9) 20 10) -4 11) 6 12) 5
 13) 3.5 14) 20.27 15) 20.423 16) 13
 17) 23.57 18) 28°C 19) £71.25 20) 19.58
 21) 15.34 22) 96.88 23) 10.33
 24) a. 36.75 b. -1.2 25) 29.25 26) a. 43 b. 8
 27) a. 66 b. 6 28) a. -6 b. 0
 29) a. 152 b. 22 30) 7.5 31) -48.8 32) 28.57

34. Forming Expressions

- 1) a) $d + 12m$ b) $d + 12m - 10$
 2) a) $£36h$ b) $2h$ c) $£12h$ d) $£48h$
 e) $£35(h + 1)$ 3) a) T + 2 miles
 b) T + 1 miles c) $2(T + 2)$ or $2T + 4$
 4) a) $£h + 8w$ b) $£h + 2$ c) $£w - 1$
 d) $£h + 8w - 6$ 5) a) $200r$ b) $£2r$ c) $£c$
 d) $£c + p$ e) $£c + 3p$ 6) a) $£C + 8A$
 b) $£2C + 14A$ 7) a) (iii) d) $4m + 2$
 8) a) $12t + e$ b) $24t + 2e$

35. Simplifying Expressions 1

Exercise 1

- 1) (i) $8x$ (ii) $4x^2$ 2) (i) $10 + 2y$ (ii) $5y$
 3) (i) $4x$ (ii) $8x$ (iii) $2x + y$ (iv) $3x + 2y$
 4) (i) x^2 (ii) $3x^2$

Exercise 2

- 1) 11 2) 5 3) 9 4) -1 5) -3 6) -3 7) 4
 8) 3 9) 6 10) -8 11) -11 12) -15 13) 3
 14) 0 15) 1 16) -6 17) -1 18) -1 19) -4
 20) 0

Exercise 3

- 1) $11y$ 2) $8y$ 3) $3y$ 4) $8x$ 5) $-2y$ 6) $8x$
 7) $-9y$ 8) $-6x$ 9) $-23a$ 10) $-19w$
 11) $15b + 5a$ 12) $12x + 13y$ 13) $7b + 8a$
 14) $7y + 2x$ 15) $4a + 7b$ 16) $8p + 10q$
 17) $8a + 2b$ 18) $4x + 6y$ 19) $6x - y$
 20) $4a + b$ 21) $-2x - 3y$ 22) $6a - 3b$

Exercise 4

- 1) $3x + 3y$ 2) $18x + 24$ 3) $8x - 12$
 4) $18x + 12$ 5) $7x + 10$ 6) $21x - 28$
 7) $17x - 12$ 8) $22x + 15$ 9) $9x - 2y$
 10) $14x - 12y$ 11) $5y + 8x$ 12) $y + 24x$

36. Simplifying Expressions 2**Exercise 1**

- 1) 8 2) 11 3) 17 4) 57 5) 122 6) 2 7) 47 8) 21
 9) -2 10) -5 11) -12 12) -6 13) 5 14) 14 15) 5
 16) 21 17) -1 18) 5 19) 25 20) 18 21) -18 22) -39
 23) -57 24) -100 25) -71 26) -75 27) -3 28) -7
 29) 1 30) -14 31) -14

Exercise 2

- 1) $6x$ 2) $8y$ 3) $11z$ 4) $12a$ 5) $5b$ 6) $6x$ 7) $8a$ 8) $-5z$
 9) $3z$ 10) $-4a$ 11) $-15x$ 12) $-4a$ 13) $-30b$ 14) $-20x$
 15) $-29b$ 16) $-19z$

Exercise 3

- 1) $7x$ 2) $-12y$ 3) $16z$ 4) $-12a$ 5) $-13b$ 6) $-2x$
 7) $-27a$ 8) $25z$ 9) $-5z$ 10) $-12a$ 11) $12x$
 12) $4a$ 13) $-3b$ 14) $-19x$ 15) $8b$

Exercise 4

- 1) $-8xy$ 2) $-7xy$ 3) $-3yz$ 4) ab 5) $-ab$ 6) 0
 7) $-5ab$ 8) $-35yz$ 9) $9yz$ 10) $5ab$ 11) $-6xy$
 12) $-13ab$ 13) $-14ab$ 14) $5xy$ 15) $-ab$

Exercise 5

- 1) $8x^2$ 2) $10x^2$ 3) $9x^2$ 4) $10x^2$ 5) $-2x^2$ 6) $2x^2$
 7) $-3x^2$ 8) $-x^2$ 9) $-4x^2$ 10) $2x^2$ 11) $-6x^2$
 12) $-70x^2$

37. Multiplying Brackets**Exercise 1**

- 1) 20 2) 21 3) -30 4) -20 5) -21 6) -63 7) 54
 8) 55 9) 48 10) -63 11) -84 12) 55

Exercise 2

- 1) $4x + 8$ 2) $5x + 35$ 3) $6x + 48$ 4) $9x + 12$
 5) $30x + 5$ 6) $15x + 6$ 7) $-2x - 6$ 8) $-4x - 8$
 9) $-6x - 42$ 10) $5x - 35$ 11) $3x - 12$ 12) $7x - 35$
 13) $-5x + 10$ 14) $-3x + 9$ 15) $-4x + 4$
 16) $-12x + 30$ 17) $-4x + 8$ 18) $-2x + 6$
 19) $12x - 12$ 20) $35x + 42$ 21) $24x - 24$

Exercise 3

- 1) $8x + 5$ 2) $5x - 11$ 3) $8x - 6$ 4) $6x - 8$ 5) $12x - 20$
 6) -11 7) $-2x - 7$ 8) $x + 19$ 9) $-13x - 6$
 10) $-25x + 28$

Exercise 4

- 1) $7x + 17$ 2) $4x + 18$ 3) $7x + 7$ 4) $9x + 7$ 5) $8x - 35$
 6) $3x - 64$ 7) $-2x - 26$ 8) $11x + 46$ 9) $-19x - 31$
 10) $-3x + 27$

Exercise 5

- 1) $x^2 + 5x + 6$ 2) $x^2 + 7x + 12$ 3) $x^2 - x - 12$
 4) $x^2 + 2x - 15$ 5) $x^2 - 2x - 8$ 6) $x^2 - 7x + 10$
 7) $x^2 + x - 6$ 8) $x^2 - 9x + 20$ 9) $x^2 + 5x - 36$
 10) $2x^2 + 2x - 12$ 11) $3x^2 - 6x - 24$
 12) $6x^2 + 19x + 15$ 13) $x^2 + 4x + 4$
 14) $x^2 - 8x + 16$ 15) $x^2 + 10x + 25$
 16) $9x^2 + 6x + 1$ 17) $4x^2 - 8x + 4$
 18) $16x^2 + 24x + 9$ 19) $x^2 - 4x + 4$

20) $4x^2 - 16x + 16$

21) $9x^2 - 30x + 25$

38. Factorising**Exercise 1**

- 1) $3(x + 2)$ 2) $5(x - 3)$ 3) $3(2x - 5)$
 4) $4(z + 3)$ 5) $4(2y + 5)$ 6) $6(3y - 1)$
 7) $4(4x - 5)$ 8) $8(2x - 3)$ 9) $2(7a - 1)$
 10) $12(2x + 3y)$ 11) $8(3x + 2y)$
 12) $7(3a + 2b)$ 13) $2(4x - 9z)$
 14) $9(2y + 3z)$ 15) $8(3p - 5q)$
 16) $3(a + 1)$ 17) $16(x + 1)$
 18) $5(1 - x^2)$ 19) $2(3a - 2b + 4c)$
 20) $5(a + 2b - c)$ 21) $3(4 - 3a + b)$

Exercise 2

- 1) $a(2 - a)$ 2) $y(6 - y)$ 3) $x(9 - x)$
 4) $x(x - 3)$ 5) $3a(1 + 2a)$ 6) $b(4 - b)$
 7) $2y(1 + 2y)$ 8) $5x(x - 2)$ 9) $4z(z - 3)$
 10) $3x(2 - 3x)$ 11) $4y(4y + 5)$
 12) $16z(2 - z)$ 13) $5a(4 - 7a)$
 14) $3x(6x - 5)$ 15) $9a(3a - 2)$

Exercise 3

- 1) $a(b + 2)$ 2) $x(4 - y)$ 3) $2a(3 - b)$
 4) $3a(1 + 2a)$ 5) $3x(3x - 2)$
 6) $x(2y + 6 - x)$ 7) $a(12b - 1 + a)$
 8) $7a(a - 2b)$ 9) $2\pi r(2r - 3)$
 10) $5y(4x + y)$ 11) $8xy(2 - z)$
 12) $4pq(2 - p)$ 13) $13pq(2p - q)$
 14) $ab(9b - a)$ 15) $4xy(4x - 3y)$

Exercise 4

- 1) $2(a + 2b)$ 2) $a(3h - a)$ 3) $5(a + 3b + 2c)$
 4) $3y(y + 7)$ 5) $4bc(a - 3c)$ 6) $2xy(3 - 7xy)$
 7) $2(7x^2 - 16y)$ 8) $7x(xy + 2)$ 9) $\pi d(3 - 7d)$
 10) $2(8a + 15x)$ 11) $9b(a - 3b)$ 12) $16a(1 + 3a)$
 13) $2a(4 + 3a - b)$ 14) $2(4x^2 + y - 3z)$
 15) $x(1 + x + y)$

39. Rearranging Formulae

- 1) $D = \frac{C}{\pi}$ 2) $r = \frac{C}{2\pi}$ 3) $m = \frac{F}{a}$
 4) $h = \frac{V}{lb}$ 5) $h = \frac{2A}{b}$ 6) $h = \frac{3V}{\pi r^2}$
 7) $c = y - mx$ 8) $m = \frac{y - c}{x}$
 9) $h = \frac{v}{\pi r^2}$ 10) $r = \sqrt{\frac{v}{\pi h}}$
 11) $F = \frac{9}{5}C + 32$ 12) $b = \frac{3}{2}y - a$
 13) $h = \frac{v^2}{2g}$ 14) $s = \frac{v^2 - u^2}{2a}$
 15) $a = \frac{2(s - ut)}{t^2}$ 16) $v = \frac{2s}{t} - u$
 17) $\frac{N^2}{4\pi^2}$ 18) $\sqrt{\frac{X}{4l}}$ 19) $\frac{3A - y}{2}$
 20) $\sqrt{6p} + y$ 21) $\sqrt{\frac{2py}{R}}$ 22) $\frac{Dx^2}{Cz}$
 23) $\left(\frac{ly}{x}\right)^2$ 24) $\frac{100I}{PT}$ 25) $\left(\frac{C - d}{t}\right)^2$

26) $\sqrt{\frac{A}{\pi} + r^2}$

27) $\sqrt{R^2 - \frac{A}{\pi}}$

28) $\sqrt{x-2a}$

29) $\frac{C(x-c)}{a^2}$

30) $\frac{a}{x^2} - a$

40. Making and Solving Equations

- 1) a) $x + 1$ b) $x + 2$ c) $3x + 3$
 d) $3x + 3 = 45$ e) 14, 15 and 16
 2) a) $y - 1$ b) $y + 1$ c) $3y$ d) 3
 e) $150 \times 3 = 450$ f) 24, 25 and 26
 3) a) $y = x + 4$ b) $7x$ and $5x + 20$
 c) $7x = 5x + 20$ d) 70cm e) 4,900cm²

41. Equations

Exercise 1

- 1) 10 2) 6 3) 8 4) 20 5) 3 6) 3 7) 2

Exercise 2

- 1) 3 2) 4 3) 11 4) 7 5) 17 6) 19 7) 3 8) -19
 9) 1 10) 4 11) 5 12) 6 13) 3 14) 9 15) 5

Exercise 3

- 1) 6 2) 4 3) 10 4) -5 5) -5 6) -7 7) 8 8) 7
 9) 6 10) 7 11) 12 12) 15 13) -2 14) -5 15) -4

Exercise 4

- 1) 4 2) 3 3) 6 4) -5 5) -3 6) -9 7) 5 8) 4 9) 6
 10) 3 11) 3 12) 2 13) 2 14) 3 15) 10 16) 3 17) 6
 18) -4

Exercise 5

- 1) 2 2) 4 3) 4 4) 2 5) 2 6) -1 7) -2 8) -2 9) 8
 10) 1.5 11) 7 12) 11 13) 10 14) 16 15) 14 16) 4
 17) 6 18) 3 19) 6 20) 4 21) 2

42. More Equations

Exercise 1

- | | | |
|--------------|--------------|--------------|
| 1) $x = 12$ | 2) $x = 12$ | 3) $x = 48$ |
| 4) $x = 8$ | 5) $x = 20$ | 6) $x = 18$ |
| 7) $x = 18$ | 8) $x = 12$ | 9) $x = 12$ |
| 10) $x = 6$ | 11) $x = 32$ | 12) $x = 90$ |
| 13) $x = 12$ | 14) $x = 12$ | 15) $x = 15$ |
| 16) $x = 9$ | 17) $x = 18$ | 18) $x = 14$ |
| 19) $x = 6$ | 20) $x = 5$ | 21) $x = 6$ |
| 22) $x = 7$ | 23) $x = 2$ | 24) $x = 13$ |
| 25) $x = 24$ | 26) $x = 20$ | 27) $x = 63$ |
| 28) $x = 40$ | 28) $x = 11$ | 30) $x = 8$ |
| 31) $x = 4$ | 32) $x = 2$ | 33) $x = 7$ |
| 34) $x = 4$ | 35) $x = 3$ | 36) $x = 5$ |

Exercise 2

- | | |
|--------------------|--------------------|
| 1) $x = 2$ or 3 | 2) $x = -1$ or 5 |
| 3) $x = -2$ or -5 | 4) $x = -2$ or 3 |
| 5) $x = -6$ or 2 | 6) $x = -4$ or -1 |
| 7) $x = -3$ or -2 | 8) $x = 3$ or 2 |
| 9) $x = -4$ or -1 | 10) $x = 4$ or 1 |
| 11) $x = -9$ or -2 | 12) $x = 9$ or 2 |
| 13) $x = 5$ or 2 | 14) $x = -5$ or -4 |
| 15) $x = -3$ or -4 | 16) $x = 5$ or -2 |
| 17) $x = -6$ or 1 | 18) $x = 10$ or -1 |
| 19) $x = 2$ or -7 | 20) $x = -2$ or 10 |

21) $x = -3$ or 7

22) $x = 3$

23) $x = 5$

24) $x = 8$ or -4

43. Simultaneous Equations

- 1) 2,1 2) 3,2 3) 2,5 4) 5,1 5) 3,2 6) 1,4 7) 3,1
 8) 4,2 9) 5,2 10) 5,4 11) 3,2 12) 2,5 13) 3,2
 14) 4,1 15) 3,1 16) 2,3 17) 3,3 18) 4,1
 19) a) $x + y = 14, x - y = 4$ b) 9,5
 20) a) $x + y = 24, x - y = 6$ b) 15, 9
 21) a) $4x + 3y = 410, 3x + y = 220$
 b) $x = 50, y = 70$
 c) Sandwich 70p, drink 50p
 22) a) $2x + 3y = 56, 3x + y = 56$
 b) $x = 16, y = 8$
 c) 16 cans and 8 cans
 23) a) $3x + 4y = 15, 4x + 3y = 16.5$
 b) $x = 3, y = 1.5$
 c) 3kg and 1.5kg

44. Using Simple Equations

- 1) $x + 1$ and $x + 2$ b) 26, 27, 28 2) a) $\frac{1}{2}x, x - 3$
 b) $2.5x - 3 = 57$ c) 24, 12, 21
 3) a) $30(x - 3)$ b) 28 c) 25cm
 4) a) 15 b) 11cm d) 253cm² 5) a) 75°, 60°, 45°
 b) 65°, 85°, 95°, 115°
 6) a) $15 - x$ b) $30x + 40(15 - x) = 500$ c) $x = 10$
 d) 10 at 30p and 5 at 40p

45. Using Quadratic Equations

- 1) a) 8 b) 5 2) 6 3) b) 10, c) 7
 4) b) 5,100 5) b) 15 c) £9, 20
 6) 9, 12, 15 7) b) 6000

46. Co-ordinates

- 1) (2,6) (6,10) (10,6) (6,2)
 2) a) (6,9) (10,11) (14,3) b) (10,1)
 3) (-3,4) (4,4) (4,-2) (-3,-2)
 4) (-6,1) (1,4) (3,4) (5,1) (5,-3) (3,-6)
 (1,-6) (-6,-3)
 5) b) (4,-1) (-5,-4) (-7,2) (2,5)

47. Sketching and Recognising Graphs 1

- 1) b 2) b 3) c
 4)



48. Sketching and Recognising Graphs 2

- 1) d 2) b 3) b
 4)



49. Recognising Graphs

- (i) b (ii) a (iii) i (iv) l (v) h (vi) g
 (vii) f (viii) j (ix) k (x) c (xi) d (xii) e

50. Plotting Graphs 1

- 1) b) Lines are parallel 2) b) 22.2
 3) c) Perpendicular 4) c) Parallel
 5) c) 0.65 6) c) (2,4) (-1,1)

51. Plotting Graphs 2

- 1) a. 7,4,12 c. 1.7, -1.7 d. (2,7) (-2,7)
 2) a. 8, -1, 4 c. (1,4) (-2,1) d. $x=1$ or $x=-2$
 3) a. 2.625, 5.875, 6.125, 9.375
 c. (0,6) (1,7) (-1,5) d. $x=-1, 0$ or 1
 4) a. 6, -3, 6, 21 c. (2.3,10) (-2.3,10)
 d. $x = 2.3$ or -2.3

52. Plotting Graphs 3

- 1) a. 9,6,5.25 c. 1.3 d. (0.8,7.6) (5.2,5.4)
 e. $x = 0.8$ or 5.2
 2) a. 5,8,13 c. Line is $x+7$,
 solution is $x = 1$ or -2
 3) a. -7, -5.25, 11 c. Line is $4x - 4$,
 solution is $x = 1.5, -0.3$ or -1.3
 4) a. 6, -1.5, -3.375 c. Line is $3 - x$,
 solution is $x = 0.8$ or $x = 6.2$

53. Straight Line Graphs

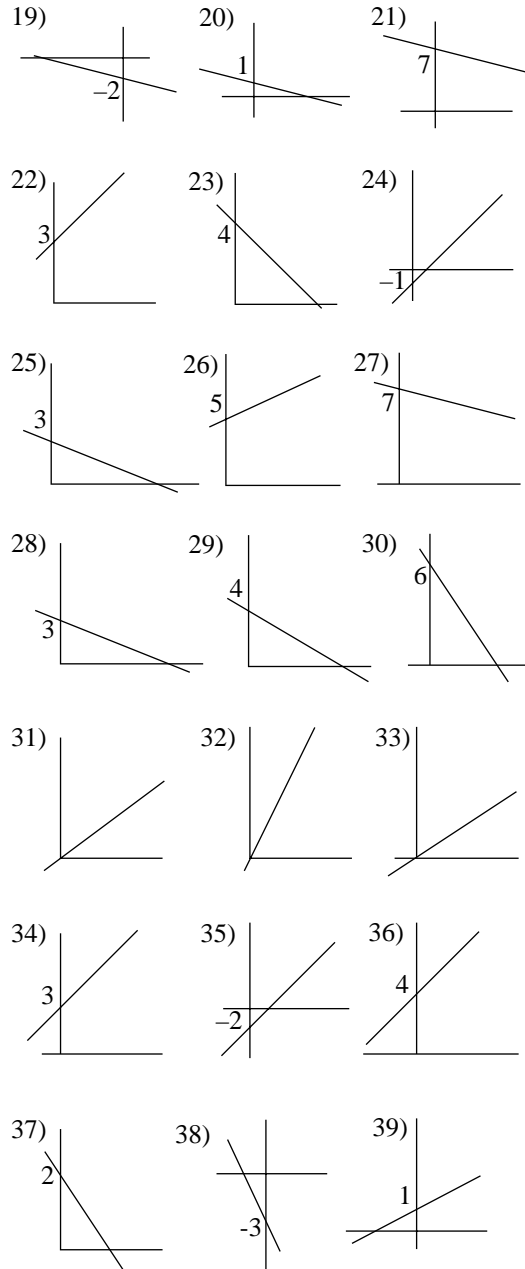
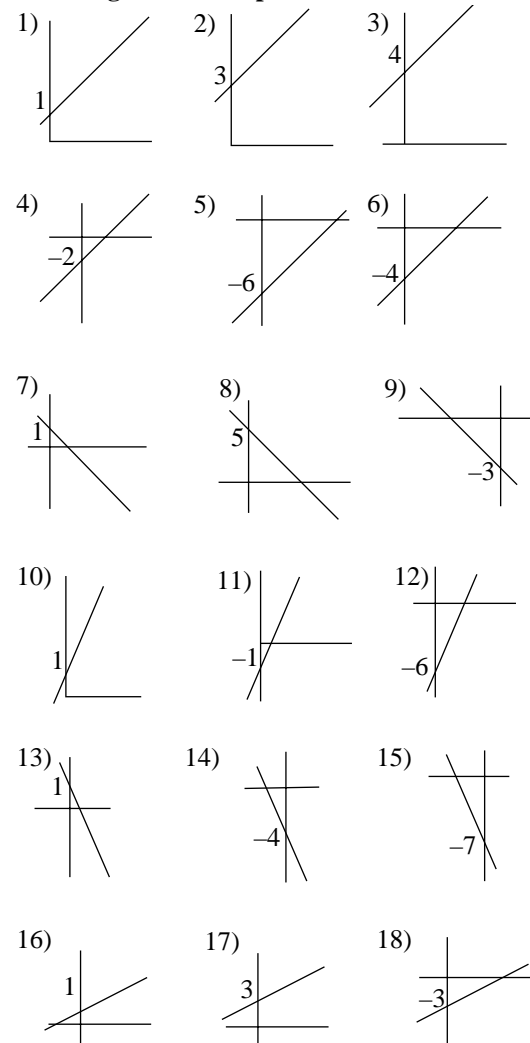

Exercise 2

- | | |
|------------------------|-----------------------|
| 1) $x = 1.5$ $y = 1.5$ | 2) $x = 1$ $y = 4$ |
| 3) $x = 2$ $y = 3$ | 4) $x = 2$ $y = 4$ |
| 5) $x = 2$ $y = -2$ | 6) $x = 0.5$ $y = 3$ |
| 7) $x = 2$ $y = 3$ | 8) $x = 3$ $y = 2$ |
| 9) $x = -1.5$ $y = 1$ | 10) $x = 3$ $y = 3$ |
| 11) $x = -1$ $y = -1$ | 12) $x = 1.5$ $y = 3$ |
| 13) $x = 3$ $y = 3$ | 14) $x = -1$ $y = 3$ |

54. Inequalities

- | | | | |
|-----------------|-----------------|----------------|------------|
| 1) $x > 3$ | 2) $x < 3$ | 3) $x > 5$ | 4) $x < 6$ |
| 5) $x > 10$ | 6) $x < 10$ | 7) $x \geq 4$ | |
| 8) $x \geq -5$ | 9) $x \leq 5$ | 10) $x \geq 3$ | |
| 11) $x < 4$ | 12) $x > -6$ | 13) $x \leq 6$ | |
| 14) $x \geq 7$ | 15) $x < 11$ | 16) $x < 9$ | |
| 17) $x > -8$ | 18) $x < 8$ | 19) $x \leq 8$ | |
| 20) $x \leq 21$ | 21) $x \leq 10$ | 22) $x < 6$ | |

- 23) $x < -14$ 24) $x > -3$ 25) $x \geq -10$
 26) $x \leq 5$ 27) $x \leq 3.5$ 28) $x < 2.5$
 29) $x > 8.5$ 30) $x < 7$ 31) $x \leq 22$
 32) $x \leq 15$ 33) $x \leq -40$ 34) $x > -12$
 35) $x > 80$ 36) $x > 42$ 37) $x \geq 10$
 38) $x < 5$ 39) $x < 5$ 40) $x > 2$
 41) $x > -2$ 42) $x > -1$ 43) $x \leq -3.5$
 44) $x \leq 2$ 45) $x \leq 3$ 46) $x > 7$
 47) $x > 9$ 48) $x > 6$ 49) $x \leq 6$
 50) $x \geq 25$ 51) $x \leq 20$

55. Inequalities - Graphs

- 1) (4,3) (5,3) (3.5,3.5) etc
 2) (3,3) (4,3) (4,4) 4.5,4.5) etc
 3) Area bounded by (4,4) (6,6) 2,3)
 4) Area bounded by (4,4) (6,6) (2,6)
 5) Area bounded by (2,1) (2,4,8) (3.8,1.9)
 6) (4,-2) and (5,1) 7) (2,4) (3,3) and (4,1)

56. Angles

- 1) 121° 2) 51° 3) $38^\circ, 57^\circ, 142^\circ$
 4) $55^\circ, 55^\circ$ 5) $47^\circ, 133^\circ$ 6) $34^\circ, 34^\circ, 146^\circ$
 7) $36^\circ, 60^\circ, 60^\circ$ 8) $71^\circ, 30^\circ, 30^\circ$
 9) $25^\circ, 60^\circ$ 10) $133^\circ, 47^\circ, 47^\circ$

57 Triangles 1

- 1) 105° 2) 60° and 150° 3) 70° and 60°
 4) 80° and 55° 5) $45^\circ, 132^\circ$ and 48° 6) 63° and 54°
 7) $121^\circ, 109^\circ$ and 130° 8) $39^\circ, 27^\circ$ and 12°
 9) $43^\circ, 43^\circ, 137^\circ$ 10) $60^\circ, 120^\circ$



58. Triangles 2

- 1) $120^\circ, 46^\circ, 134^\circ$ 2) $72^\circ, 72^\circ, 36^\circ$ 3) $47^\circ, 78^\circ, 102^\circ$
 4) $75^\circ, 34^\circ, 71^\circ$ 5) $79^\circ, 113^\circ, 34^\circ$ 6) $90^\circ, 55^\circ, 35^\circ$
 7) $120^\circ, 26^\circ$ 8) $50^\circ, 40^\circ$

59. Shapes

- a) Octagon b) Parallelogram c) Quadrilateral
 d) Cuboid e) Triangle f) Kite g) Hexagon
 h) Cube i) Trapezium j) Triangular prism
 k) Circle l) Cylinder n) Square o) Cone
 p) Rectangle q) Pyramid r) Pentagon

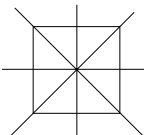
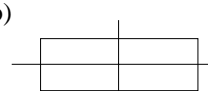
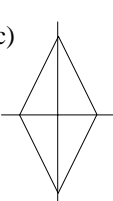

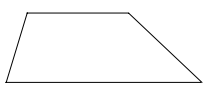

60. Quadrilaterals

- 1) a)  b) 
 c)  d) 
 e) 

- 2) $127^\circ, 53^\circ$ 3) $90^\circ, 56^\circ$ 4) 142° 5) 65°

- 6) 120° 7) a) AOB, AOD, DOC b) $90^\circ, 45^\circ$
 8) a) Isosceles triangle b) AOD
 c) AOB and DOC d) $48^\circ, 66^\circ, 24^\circ$.

61. Regular Polygons

- 1)  2)  3)  4) 

- 5) a) Equal in length b) 72° c) $54^\circ, 54^\circ$
 6) a) 45° b) $67.5^\circ, 67.5^\circ$ c) 135° d) 45°
 7) a) 51.4° b) 64.3° c) 128.6° d) 51.4°
 8) 8 9) The interior angle of a pentagon is not a factor of 360° . The interior angle of a hexagon (120°) is a factor of 360° . Therefore three of these angles will fit together to make 360° .
 10) 9

62. Irregular Polygons

- 1) 65° 2) 125° 3) 105° 4) 120°
 5) $80^\circ, 160^\circ$ 6) 120° 7) 72° and 144°
 8) 135° 9) 140° 10) 290°

63. Congruency

- 1) a) DEF b) BAC c) FD d) (iii) (iv)
 2) a) $\angle BAC = \angle CED, \angle ABC = \angle CDE$
 $\angle ACB = \angle DCE$ b) $AB = DE, BC = CD, AC = CE$
 3) a and c

64. Tessellations

- 2) Four corners of 90° will fit together around a point to make 360° . 145° will not divide into 360° exactly.
 3) a) Square b) Rhombus c) Rhombus

65. Nets and Isometric Drawings 1

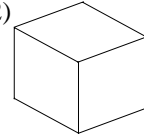
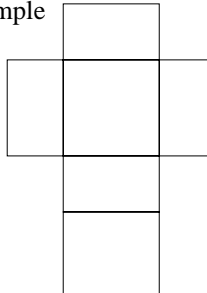
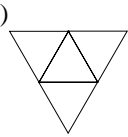
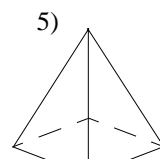
- 1) a, c, d, f
 2) 
 3) Example 
 4) 
 5) 

66 Nets and Isometric Drawings 2

- 1)  2) 

3) a) 6 b) 4 and 2

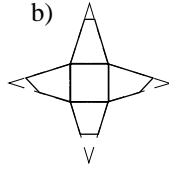
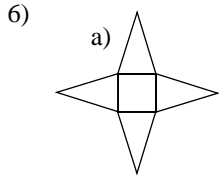
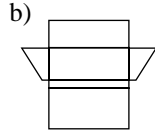
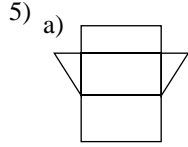
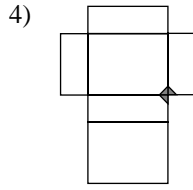
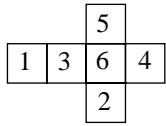

67. Reflection Symmetry

1) a, b, c, g, i.

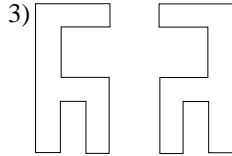
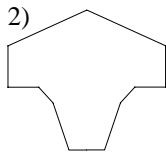

4) i, p, x, s.

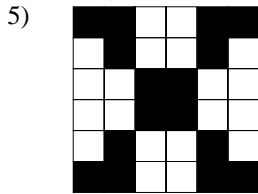

68. Reflection

- 1) (-1,4) (-6,4) (-6,10)
- 2) (0,2) (-5,2) (-5,10) (0,10) (0,7) (-3,7) (-3,5) (0,5)
- 3) (2,0) (0,5) (2,10) (4,5)
- 4) (3,-1) (9,-3) (3,-8)
- 5) (1,1) (8,1) (10,-4) (3,-4)

69. Enlargements

70. Rotational Symmetry

- 1) a) 3 b) 4 c) 5 d) 10 e) 3 f) 6 g) 3 h) 2
i) 6 j) 3 k) 3 l) 4 m) 6 n) 6 p) 4 q) 2
- 2) I, S, X, Z.

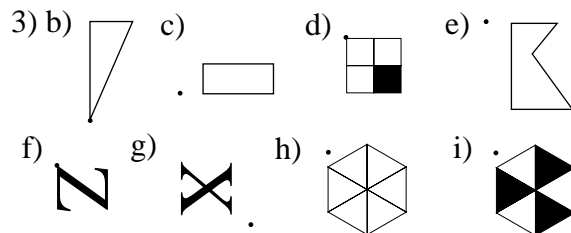

71. Rotation

- 1) (-1,-1) (-1,-3) (-3,-3)
- 2) (2,4) (2,8) (9,8)

- 3) (-2,3) (-9,3) (-9,7) (-2,7)
- 4) Rotation of 90° clockwise about point (-3,2)

72. Translations 1

- 1) (0,3) (5,3) (4,9)
- 2) (-3,3) (-8,3) (-6,8) (-1,8)
- 3) (4,-2) (7,-2) (10,-6) (2,-6)
- 4) (2,8) (7,8) (9,6) (4,3) (5,6)

73. Translations 2

- 1) c) (2,3) (2,1) (4,1)
- 2) c) (2,-2) (4,-2) (4,-4) (2,-4)
- 3) c) (-5,-3) (-2,-3) (-2,-1) (-4,-1)

74. Reflections, Rotations and Translations 1

- 1) a. (2,-1) (4,4,-4) (2,-4)
b. (-2,1) (-4,4,4) (-2,4)
c. (-5,-4) (-2,-1.6) (-2,-4)
- 2) a. (1.6,-1) (1.6,-3) (-1,-3) (-1,-1)
b. (-4,-0.6) (-6,-0.6) (-6,2) (-4,2)

75. Reflections, Rotations and Translations 2

- 1) a. (2,3) (2,-1) (0,-2) (-2,-1) (-2,3) (0,4)
b. (-5,-1) (-1,-1) (0,-3) (-1,-5) (-5,-5) (-6,-3)
- 2) a. (4,2) (4,0) (-1,-2) (-1,0)
b. (-6,0) (-4,0) (-2,-5) (-4,-5)

76. Enlargement Through a Point 1

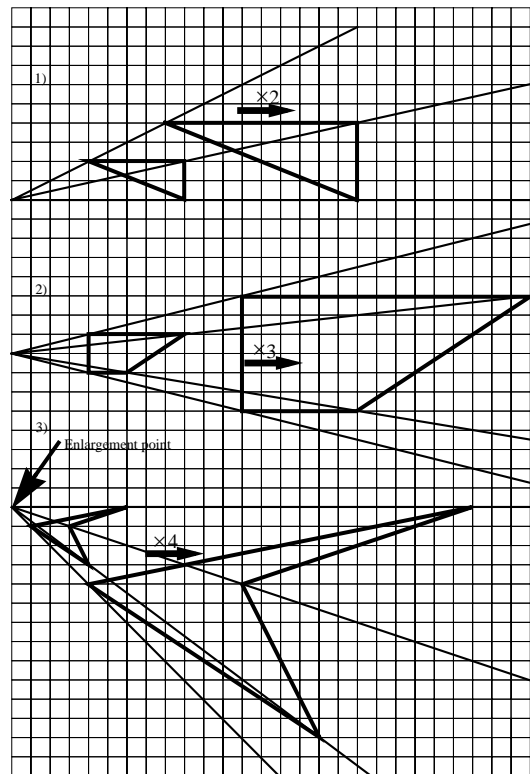

77 Enlargement Through a Point 2

1)

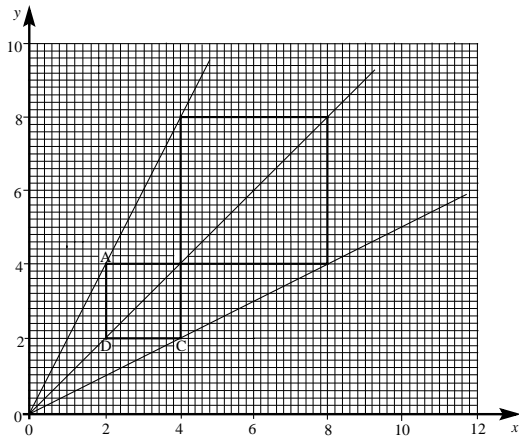

2)

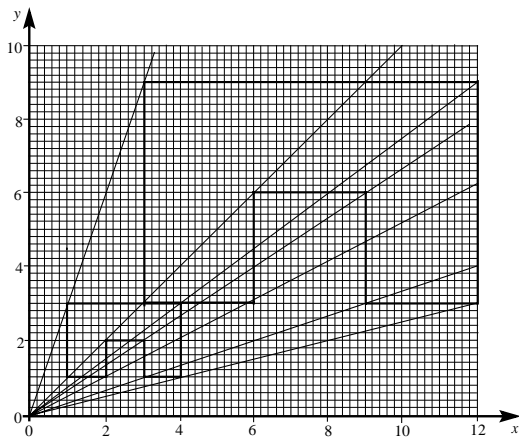

78 Enlargement Through a Point 3

1)

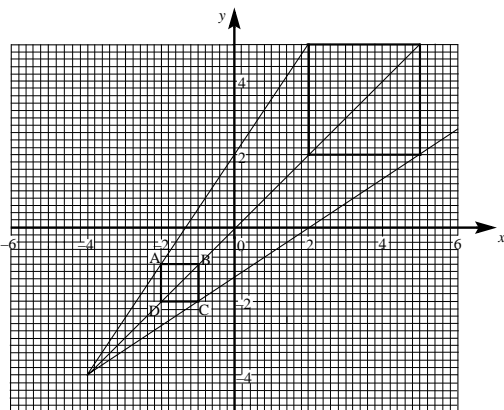

2)

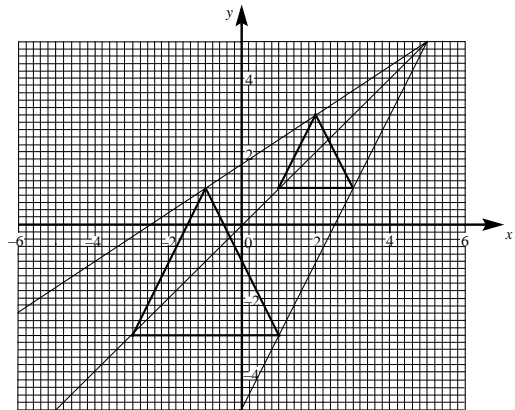

79. Planes of Symmetry

- 1) No 3 2) 9 3) a) 1 b) 1 4) A and D

80. Similar shapes

- 1) a) 2 b) 4 c) 3 d) 9 2) a) XYZ b) 8cm c) $3\frac{1}{2}$ cm
d) 4 3) a) BXY b) ABC c) XBY d) 6cm e) 2cm

81. Locus Problems 1

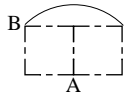
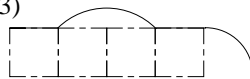
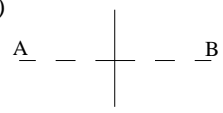
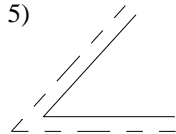
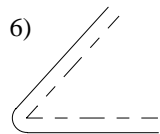
- 1)  2) 
- 3)  4) 
- 5)  6) 

82. Locus Problems 2

1)

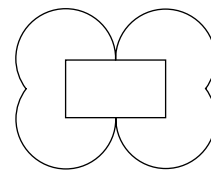

2)



3)

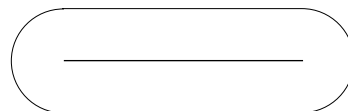

4)

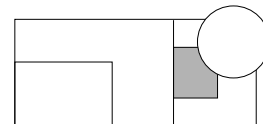

5) 9.4km

83. Constructions

84. Scale Drawings

- 1) 7.4 cm 2) 4.5 cm 3) 80 metres 4) 15.4 metres

85. Plans

- 1) a) 50cm b) 9.1cm, 5.5cm
 c) 4.55 metres, 2.75 metres d) 122.5cm, 62.5cm
 2) 40cm, 4 metres, 12.5cm, 2
 3) a) 3cm b) 1:10 c) 11.5cms
 4) a) 4:1 b) 9mm
 5) 30 cm, 2 cm, 1 cm, 4.

86. Plans and Elevations 1

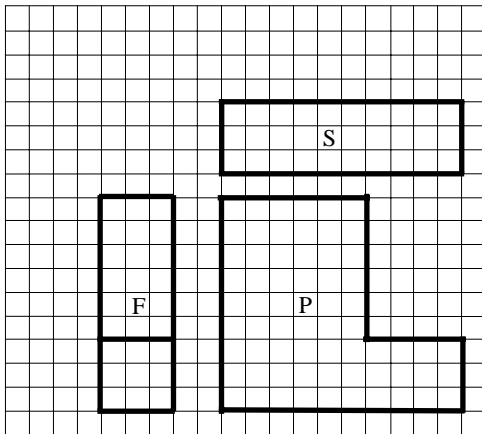

87. Plans and Elevations 2

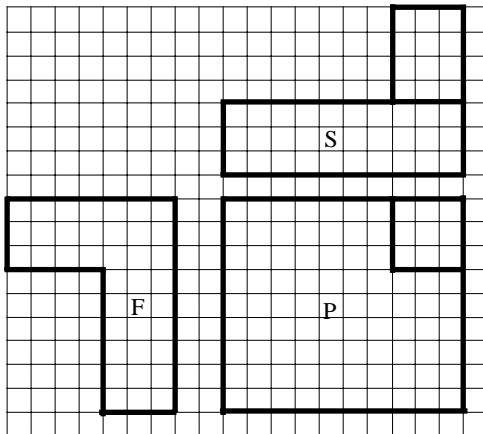

88. Plans and Elevations 3

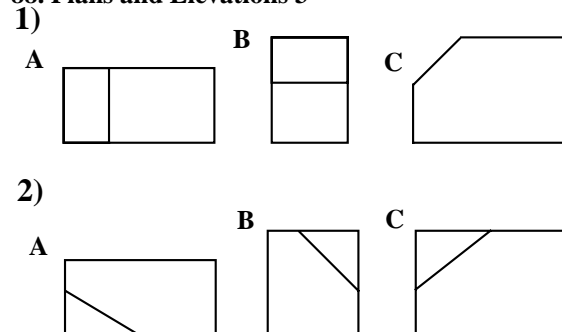

89 Plans and Elevations 4

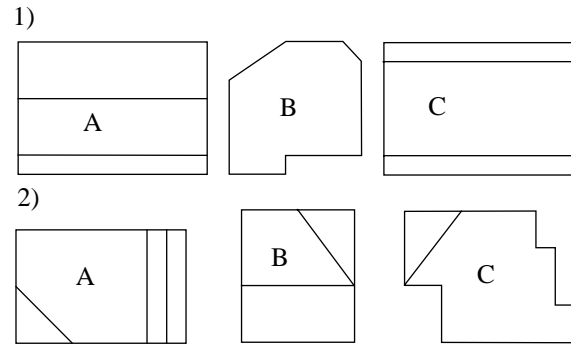

90. Using Measurements

- 1) a) 77 mm b) 7 cm 7 mm c) 7.7 cm
 2) a) 95 mm b) 9 cm 5 mm c) 9.5 cm
 3) a) 3.1 b) 3.8 4) a) (i) 700ml (ii) .7L
 b) more 5) a) kilograms b) 68 kg
 c) 92kg d) 24kg e) 150 pounds, 202 pounds
 f) 10 stones, 10 pounds and 14 stone 6 pounds
 6) 90 km 7) 5 feet 10 inches 8) 22 gallons
 9) 2 litres are greater than 3 pints, 2 kgs are greater than 4 pounds

91 Degree of Accuracy

Exercise 1

- 1) a) 400 b) 1400 c) 180 d) 1600 e) 3100 f) 35,000
 g) 15,000 h) 23,000
 2) a) 37,580 b) 37,600 c) 38,000 d) 40,000
 3) b, d, e, f, h
 4) a) 225 to 234 b) 4350 to 4449
 c) 37,500 to 38,499 d) 1835 to 1844
 e) 35,000 to 44,999 f) 10,950 to 11,049
 g) 2250 to 2349 h) 755 to 764
 i) 34,250 to 34,349 j) 135,000 to 144,999

Exercise 2

- 1) 87.5 2) $\leq, <$ 3) $<, 27.55$ 4) 5.665, 5.675 5) $\leq, <$

92. Bearings

Exercise 1

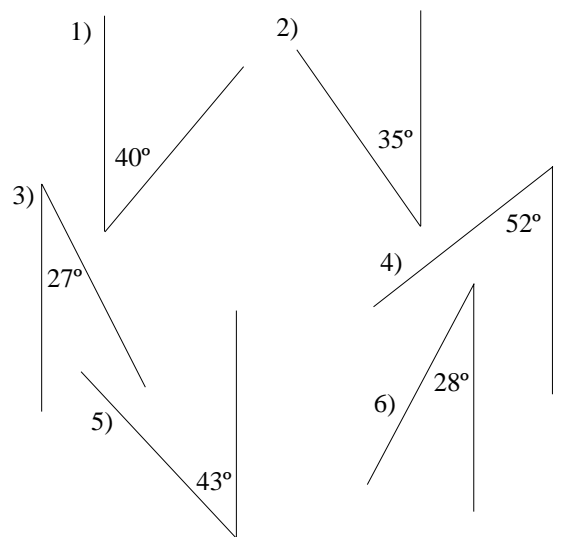

Exercise 2

- 1) N28°W (332°) 2) N28°E (028°) 3) S58°W (238°)

Exercise 3

- 1) a) 43 km (N89°W or 271°)
b) 73 km S 80°E (100°)
c) 25 km S 32°W (212°)
2) 9.4km S 87°E (093°)
3) 153 km S 33°W (213°)

93. Areas and Perimeters 1

- 1) A 8,12 B 8,14 C 5,12 D 7,14 E 7,16
F 9,12 G 6,14 H 6,12
2) B 3) 62 4) 30 m, 38 m²
5) a) 243 tiles b) 16 m 80 cm c) 84
6) a) 216 cm² b) 84 m² c) 72 m² 7) 60 cm²

94. Area and Perimeter 2

- 1) a) 20cm² and 18cm b) 81cm² and 36cm
c) 17.5cm² and 19cm d) 16.8cm² and 17.6cm
e) 112.8m² and 42.8m f) 1330cm² and 178cm
g) 0.48m² and 3.2m h) 855cm² and 128cm
i) 6.825m² and 10.9m
2) a) 19.25cm² b) 21.15cm² c) 54cm² d) 40.5cm²
3) a) 63cm² and 48cm b) 57cm² and 44cm
c) 73.25cm² and 51cm d) 50cm² and 47cm

95. Circumference of a Circle

Exercise 1

- 1) 18.84cm 2) 31.4cm 3) 75.36cm 4) 100.48cm
5) 43.96cm 6) 81.64m 7) 31.4cm 8) 69.08cm
9) 106.76cm 10) 5.652m 11) 59.66m 12) 109.9m

Exercise 2

- 1) 9.554cm 2) 27.07cm 3) 54.14cm 4) 7.643m
5) 49.04m 6) 74.84m

Exercise 3

- 1) a) 219.8cm b) 43.96m 2) a) 31.4m b) 628m
3) 41m 4) 37.68m 5) 2826m 6) 5587revs 7) 91 turn

96. Area of Circles

- 1) a) 7.065cm² b) 200.96mm² c) 50.24mm²
d) 28.26cm² e) 7.065cm² f) 12.56cm²
2) a) 78.5cm² b) 28.26cm² c) 19.63cm²
d) 452.2cm² e) 254.3cm² f) 176.6cm²
g) 16.61cm² h) 58.06cm² i) 55.39cm²
3) a) 113.04cm² b) 1.766cm² c) 111.27cm²
4) Square 6.25cm² Circle 7.065cm². Circle is larger.
5) a) 50.24 m² b) 78.5 m² c) 28.26 m²

97. Volume 1

- 1) 27cm³ 2) 63cm³ 3) 72 cm³ 4) 30 cm³
5) 24 6) 3 × 12 × 4 or 3 × 6 × 8 etc 7) 4 cm

98. Volume 2

Exercise 1

- 1) 5000 2) 20 3) 1 4) 0.02 5) 4,200,000
6) 100,000 7) 20 8) 0.42 9) 1500 10) 100
11) 7500 12) 5

Exercise 2

- 1) 14 and 6 2) 4500cm² 3) 15.3m³ 4) 243
5) a) 529.875cm³ b) 530ml 6) 7850 7) 141cm³
8) 8 9) 250cm 10) 1.055cm 11) a) 50cm by 25cm
b) 2231.25cm² c) 669.4 litres

99. Formulae for Area, Volume and Perimeter 1

Exercise 1

- 1) a) (iii) b) (v) 2) a) (v) b) (iv)
3) a) (i) b) (iv) 4) a) (vi) b) (iii)
5) a) (v) b) (ii)

100. Formulae for Area, Volume and Perimeter 2

- 1) (i) She is trying to get a length of cable.
Multiplying L, W and H together gives a cubic measurement
(ii) 'a' because all the dimensions are in length.
All the others give either area or volume measurements.
2) Area. 4, 5, 11, 14, 16 Volume. 7, 20
Perimeter 3, 9, 18

101. Time

- 1) a) 40 minutes b) 50 minutes c) 1 hr 45 mins
d) 1 hr 20 mins
2) a) 3 hours 45 minutes b) 4 hours 6 minutes
c) 1 hour 53 minutes d) 2 hours 49 minutes
e) 3 hours 4 minutes f) 6 hours 48 minutes
3) 5:50 4) 2:30 pm 5) 6 hours 40 minutes
6) a) 3:53 pm 5:06 pm b) 1 hour 13 minutes
7) Hannah
8) a) 16:12 b) 8 hours 34 minutes
9) 7 hours 22 minutes

102. Density

- 1) a) 2.5g b) 2.4g 2) 3 red and 2 blue 3) 6 and 4 etc
4) a) 4.5g b) $4\frac{2}{3}$ g 5) a) 16cm³ b) 140.2g
c) 8.7625g/cm³ 6) 17cm³ b) 77.4g c) 4.553g/cm³
7) 9 copper and 9 alloy

103. Best Buy and Painting

Exercise 1

- 1) 500g 2) $1\frac{1}{2}$ litres 3) 80 4) 1kg 5) 745g

Exercise 2

- 1) a) 108m² twice b) 16.62 litres c) 20 litres
2) a) 78m² b) 15.6 litres c) 31.2 litres
d) 37.44 litres e) 40 litres

104. Speed

- 1) 50 mph 2) 32 mph 3) 40 kpm
4) 26.25 mph 5) a) 38 miles b) 76 mph
6) a) 15 km b) 30 kph 7) 40 km per hour
8) 50 mph 9) 60 kph 10) 60 miles
11) 75 miles 12) 125 km 13) 75 km
14) 126 miles 15) 2 hours
16) 1 hour 30 minutes 17) 15:20 or 3:20 pm
18) 10:35 am 19) 12:45 am.

105. More Best Buys

- 1) Matthew 2) Supermarket 3) 1 litre
 4) 700 g 5) 1 litre 6) 125 ml 7) 500 ml
 8) 450 g tin 9) 4 litre 10) 200 ml tube

106. Pythagoras Theorem

- 1) a. 15cm b. 10cm c. 12.53cm
 2) a. 3.606cm b. 8.139cm c. 11.53cm
 3) 5.657cm 4) 12.37cm 5) 4.899cm
 6) 40.82cm 7) 15cm 8) 4.031cm
 9) 9.899cm 10) 6.062cm 11) 4.583cm
 12) 3m 32cm 13) 8.485cm

107. Trigonometry 1

- 1) a. 6.143 b. 9.801 c. 12.08 d. 4.404
 e. 12.76
 2) a. 44.90° and 45.10°
 b. 49.79° and 40.21°
 c. 38.68° and 51.32° d. 26.39° and 63.61°
 e. 36.87° and 53.13°
 3) a. 5.866 b. 8.428 c. 12.34 d. 15.83
 e. 14.37

108. Trigonometry 2

- 1) a. 4.045 b. 6.343 c. 1.915 d. 5.891
 e. 5.634
 2) a. 25.84° and 64.16° b. 45.57° and 44.43°
 c. 31.86° and 58.14° d. 38.57° and 51.43°
 e. 39.36° and 50.64°
 3) a. 6.625cm b. 15.42cm c. 11.65cm
 d. 15.45cm e. 16.35cm

109. Trigonometry 3

- 1) a. 5.124 b. 5.211 c. 5.684 d. 55.60
 e. 18.22
 2) a. 59.53° and 30.47° b. 53.97° and 36.03°
 c. 42.51° and 47.49° d. 61.39° and 28.61°
 e. 36.25° and 53.75°
 3) a. 16.66 b. 10.70 c. 43.09 d. 31.40
 e. 5.750

110. Trigonometry 4

- a. $x = 4.292$ b. $x = 15.65$
 c. 49.81° and 40.19° d. $x = 4.890$
 e. 27.09° and 62.91° f. 42.37° and 47.63°
 g. 17.46° h. 18.71° i. 4.201m, 1.613m
 j. 4.047cm k. 5.711°

111. Surveys and Questionnaires





- 1) (i) is b (ii) is c (iii) is a
 2) (i) Examples. Do you want a supermarket in town?
 Do you use a supermarket regularly?
 Do you regularly shop in town?
 (ii) As part (i)
 3) Examples. Do you like sandwiches?
 Which do you prefer out of sandwiches, pizza etc?
 How much would you pay for sandwiches?

4) a) Something like;

‘The local council want to close the cinema to make it into a night club. I am against this’

112. Pictograms

- 1) a) 125 b) 45 c) 15
 2) a) 30 b) 45 c) 15 d) 585
 3)

Badminton	
Squash	
Netball	
Rounders	
Hockey	

113. Pie Charts 1

- 1) a) 25% b) $\frac{1}{8}$ c) 125 2) a) $\frac{1}{3}$ b) 6 hrs
 3) Angles are 80°, 120°, 80°, 20°, 60°
 4) a) 10° b) 100°, 140°, 70° and 50°
 5) Angles are 75°, 150°, 90° and 45°
 6) a) 6° b) 60°, 150°, 120°, 30°

114. Pie Charts 2

- 1) a) 10° b) 150°, 100°, 80°, 30°

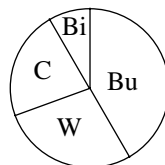

2) a)

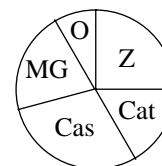

b) It would stay the same

- 3) a) (i) Ben (ii) Holly (iii) 25% (iv) 19.4%
 b) Ben c) Phillipa's area is greater than Ben's but Ben spends more money altogether so even though his food area is smaller than Phillipa's it could represent more money than Phillipa's.

115. Bar Charts

- 1) a) Semi detached b) 5 c) 30 2) a) 40 b) 35
 c) 50 d) 195
 3)

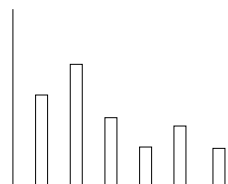

116. Stem and Leaf Diagrams

- 1) a) 50 b) 3
 2) a) 20, 30, 40, 50, 60
 b) 2 0, 5, 9, 6, 6, 2
 3 4, 9, 7, 2, 6, 7, 2, 6, 4
 4 2, 1, 2, 5, 4
 5 1, 4, 0
 6 0
 3) a) 44 b) 143 and 80 c) 63

- 4) a) 100, 200, 300, 400, 500, 600
 b) 1) 96, 90, 85, 85
 2) 15, 22, 31, 57, 06
 3) 14, 14, 65, 61, 74, 94
 4) 61, 85, 72, 10, 22, 38, 36, 07, 12, 34
 5) 14, 94, 42, 33
 6) 08

- 1) 34.14mph 2) 36.77mph 3) 43.57
 4) 38.13 5) 31.08mpg 6) 30.2
 7) a. Grade 2 b. Grade 3
 c. Grade 1. Grade 2
 8) 10.7, 10.6, 10.5, 10.5, 10.5, 10.2, 10.1, 10.1, 10.2,
 10.8, 10.7, 10.6
 October

117. Box Plots

- 1) a) 96 b) 18 c) 53 d) 42 e) 68 f) approx 75
 g) approx 75
 2)

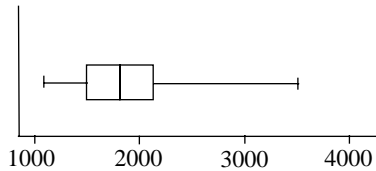

3)

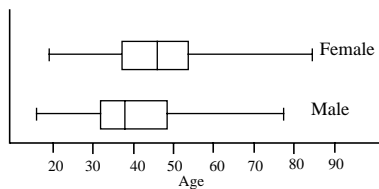

In all areas the female values are higher than those of the male. This may not be significant in the highest and lowest values as they may be rogue but the lower and higher quartiles do show that the average ages of the female members are higher than those of the males.

118. Line Graphs

- 1) b) The temperatures in Europe are high in July and low in January. The temperatures in Australia are low in July and high in January.
 2) b e.g. most egg timers were within 2 seconds of 4 minutes.

119. Scatter Diagrams 1

- 1) Positive correlation, no correlation and negative correlation (i) c) (ii) a) (iii) b)
 2) a) About 58 b) about 65 3) About 90

120. Scatter Diagrams 2

Answers are approximate

- 1) a. 56 b. 79
 2) 58 3) 57kg 4) 11.8cm 5) 40

121. Mean 1

- 1) 4.75 2) 6.8 3) 53 4) 11.5
 5) a) 32 b) 28 6) a) 15 b) No
 7) a) By multiplying together the top two rows
 b) 30, 28, 20 c) 90 d) 3 8) a) 65 b) 2.5
 9) 4

122. Mean 2

123. Mean 3

- 1) 2.345 2) 2.3 3) 0.2087 4) 5.64

124. Mean 4

- 1) 1.658 2) 5.462 3) 2.051

125. Mean 5

- 1) Mean 156.3cm
 Modal Class 150–160
 2) Mean 5016
 Modal Class 5000–5010
 3) Mean 223.92
 Modal Class 280–320
 4) Mean 28 hours 52 mins
 Modal Class 25–30
 5) Mean 42.2cm
 Modal Class 42–43

126. Grouped Frequency

1)	0-10	0
	11-20	1
	21-30	4
	31-40	5
	41-50	5
	51-60	9
	61-70	3
	71-80	2
	81-90	3
	91-100	1
2)	1-2	7
	3-4	27
	5-6	11
	7-8	5
	9-10	1
3)	1-4	11
	5-8	9
	9-12	3
	13-16	10
	17-20	2
	21-24	1

127. Median, Mode and Range

1)	1	8
	2	7
	3	7
	4	6
	5	4
	6	3

	7	1
2)	0	6
	1	6
	2	11
	3	5
	4	3
	5	2
	6	4
	7	4
	8	6
	9	3
a) 2 b) 9		
3)	13	7
	14	10
	15	13
	16	8
	17	7

- a) 15 b) 4
 4) 5 and 9 5) 6 and 7 6) 69 and 78

128. Mean, Median, Mode and Range

The following answers are examples and in some cases are more detailed than required.

- 1) Either a) 4 seats because more families have 4 members than any other number or b) 5 seats because this covers all family sizes up to 5
- 2) It is not known the exact ages of the people who are less than 14 and over 16.
- 3) The ages of the second group are more spread out than the ages of the first group.
- 4) Type A – as they have a smaller range they are more reliable.
- 5) Size 8 – she sells more of this size than any other size.
- 6) The mean will go down slightly (to 94.1).
The range could go down or stay the same eg if it was 88 to 100 then there would be a change.
- 7) The mean will increase slightly (to 1.57).
The mode will stay the same at 2. If there are now the same number of 2's as there are 3's then both these numbers will be modes. However, since the mean is only 1.5 it seems more likely that there are not many 3's compared with 2's so the mode will stay the same.
- 8) The median will either be lower, or if there are a number of 23's it could stay the same. If 30 and 15 lie between the top and bottom mark then there will be no change in the range. If 30 is the largest number, or 15 the smallest then the range could change.

129. Moving Averages

- a) Saturday
- b) There has to be at least 7 days for this moving average to be calculated
- c) Day 7
- d) 7 £331.00 £246.43

8	£275.00	£255.71
9	£150.00	£257.86
10	£310.00	£269.29
11	£345.00	£268.57
12	£235.00	£267.86
13	£295.00	£274.29
14	£350.00	£280.00
15	£295.00	£282.86
16	£145.00	£282.14
17	£375.00	£291.43
18	£355.00	£292.86
19	£265.00	£297.14
20	£305.00	£298.57

e) The sales are increasing

130. Frequency Polygons

Exercise 1

1

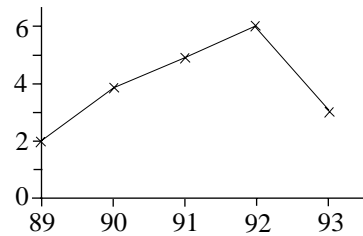

2)

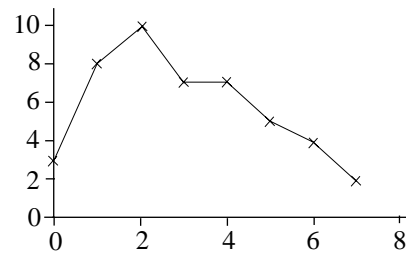

3)

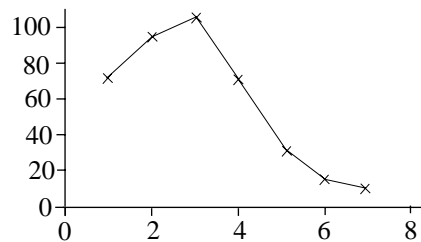

4)

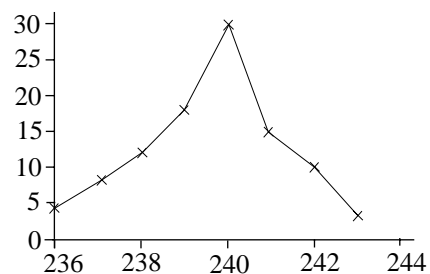

Exercise 2

1)

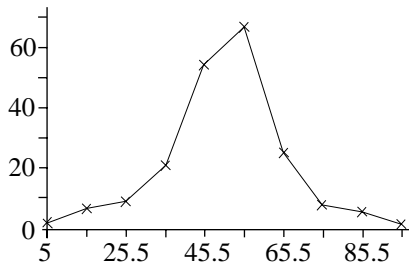

2)

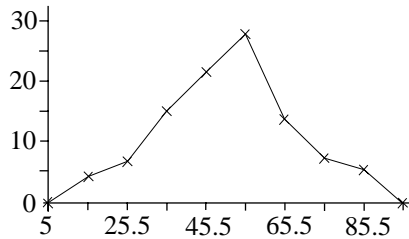

3)

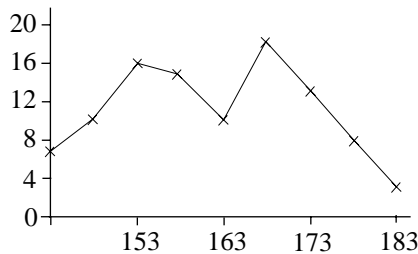

4)

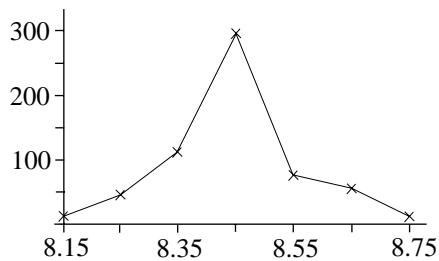

131. Cumulative Frequency 1

1) a.

80 100 130 150 180
7 22 63 83 90

c. (i) £117 (ii) £34 (iii) 41

2) a.

65 70 75 80 85 90
15 41 77 95 105 110

c. (i) 72 (ii) 97

132. Cumulative Frequency 2

1) a.

30 40 50 60 70 80 90
3 29 70 118 155 181 186

c. (i) 54mph (ii) 168

2) a.

11 13 15 17 19

4 14 33 47 50

b. (i) 14.2 hours (ii) 2.9 hours. 17.6%

3) a.

20 40 60 80 100
10 32 68 82 84

c. (i) 46 (ii) 9

133. Probability 1

1)

	1	2	3	4	5	6
1	2	3	4	5	6	7
2	3	4	5	6	7	8
3	4	5	6	7	8	9
4	5	6	7	8	9	10
5	6	7	8	9	10	11
6	7	8	9	10	11	12

2) (A,B) (A,C) (A,D) (A,E) (B,C)
(B,D) (B,E) (C,D) (C,E) (D,E)

3)

	1	2	3	4
1	2	3	4	5
2	3	4	5	6
3	4	5	6	7

4) (1,1) (1,2) (2,1) (2,2) (3,1) (3,2)
5) (1,1) (1,2) (1,3) (1,4) (2,1) (2,2)
(2,3) (2,4) (3,1) (3,2) (3,3) (3,4)

134. Probability 2

1)

	1	1	2	2	3	3
1	2	2	3	3	4	4
1	2	2	3	3	4	4
2	3	3	4	4	5	5
2	3	3	4	4	5	5
3	4	4	5	5	6	6
3	4	4	5	5	6	6

a) $\frac{4}{36}$ or $\frac{1}{9}$ b) $\frac{12}{36}$ or $\frac{1}{3}$ c) $\frac{12}{36}$ or $\frac{1}{3}$

2)

	1	2	3	4
1	■	3	4	5
2	3	■	5	6
3	4	5	■	7
4	5	6	7	■

a) $\frac{2}{12}$ or $\frac{1}{6}$ b) $\frac{8}{12}$ or $\frac{2}{3}$

3) a) (1,A) (1,B) (1,C) (2,A) (2,B) (2,C)
(3,A) (3,B) (3,C) (4,A) (4,B) (4,C)

b) $\frac{1}{12}$ b) $\frac{3}{12}$ or $\frac{1}{4}$

4) (1,1) (1,2) (2,1) (2,2) (3,1) (3,2)

- a) $\frac{1}{6}$ b) $\frac{2}{6}$ or $\frac{1}{3}$ c) $\frac{1}{6}$

135. Probability 3

- 1) a Unlikely b Unlikely c Even d Likely

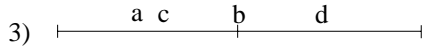

- 4) 0, no chance; 0.1, very unlikely;
0.3, unlikely; 0.5, even; 0.7, likely;
0.9, very likely; 1.0, certain
- 5) 0%, no chance; 5%, very unlikely;
19%, unlikely; 50%, even; 67%, likely;
98% very likely; 100% certain.
- 6) Good. On his past performance it has 5 chances out of 7 of winning.
- 7) 5 chances out of 1000 is not a good chance.
- 8) Yes. There have been 156 cars out of 257 which is better than an even chance.
- 9) Only if the number of girls entering the competition is the same as the number of boys entering it.

136. Probability 4

- 1) $\frac{1}{6}$ 2) $\frac{4}{52}$ or $\frac{1}{13}$ 3) $\frac{15}{35}$ or $\frac{3}{7}$ 4) $\frac{10}{200}$ or $\frac{4}{52}$
- 5) $\frac{10}{20}$ or $\frac{1}{2}$ 6) $\frac{3}{6}$ or $\frac{1}{2}$ 7) a) $\frac{1}{6}$ b) $\frac{3}{6}$ or $\frac{1}{2}$
- c) $\frac{5}{6}$ 8) a) $\frac{5}{12}$ b) $\frac{4}{12}$ or $\frac{1}{3}$ c) $\frac{9}{12}$ or $\frac{3}{4}$
- 9) a) $\frac{5}{1000}$ or $\frac{1}{200}$ b) 100 10) a) 4 b) 20
- c) 0 11) a) $\frac{1}{10}$ b) $\frac{4}{10}$ or $\frac{2}{5}$ c) $\frac{9}{10}$ 12) $\frac{5}{6}$

because there are 5 other numbers that can be obtained.

137. Probability 5

- 1) $\frac{5}{36}$
- 2) a) $\frac{4}{36}$ or $\frac{1}{9}$ b) $\frac{12}{36}$ or $\frac{1}{3}$ c) $\frac{12}{36}$ or $\frac{1}{3}$
- 3) a) $\frac{2}{20}$ or $\frac{1}{10}$ b) $\frac{16}{20}$ or $\frac{4}{5}$

138. Tree Diagrams

- 1) a) $\left(\frac{2}{5}\right), \left(\frac{3}{5}\right), \left(\frac{2}{5}\right)$ b) $\frac{6}{25}$ c) $\frac{9}{25}$
- 2) a) 0.06 b) 0.56 c) 0.38
- 3) $\frac{3}{5}, \frac{5}{8}, \frac{3}{8}, \frac{5}{8}$ a) $\frac{3}{8}$ b) $\frac{9}{40}$ c) $\frac{19}{40}$
- 4) a) $\frac{13}{25}$ b) $\frac{6}{25}$ c) $\frac{6}{25}$
- 5) a) $\frac{5}{18}$ b) $\frac{1}{2}$ c) $\frac{13}{18}$

139. Relative Frequency 1

- 1) 25
- 2) a) (i) $\frac{1}{15}$ (ii) $\frac{1}{2}$ b) (i) 50 (i) 20
- 3) a) $\frac{1}{2}$ b) Too few throws c) 250
- 4) a) $\frac{3}{8}$ b) 625

140. Relative Frequency 2

- 1) a) One number would occur more times than each of the others. b) 7 c) 77
- 2) a) $\frac{4}{25}$ b) 200 c) 32 d) approx 60 and 20
- 3) a) Approx 11, 6, 3 b) 120 4) a) 17.5% b) 3 or 4
- c) 20 5) a) $\frac{39}{40}$ b) 125 c) 5800