

EXISTING CAMPUS ADDS, MOVES & CHANGES

DIVISION 27 - COMMUNICATIONS

27 05 05	COMMON WORK RESULTS COMMUNICATIONS
27 05 26	GROUNDING BONDING
27 05 28	PATHWAYS FOR COMMUNICATIONS SYSTEM
27 10 70	COMMUNICATIONS TESTING IDENTIFICATION AND ADMINISTRATION
27 11 16	COMMUNICATIONS CABINETS AND ENCLOSURES
27 11 19	COMMUNICATIONS PATCH PANELS
27 13 23	COMMUNICATIONS OPTICAL FIBER BACKBONE CABLING
27 15 00.19	DATA COMMUNICATIONS HORIZONTAL CABLING
27 15 43	COMMUNICATIONS FACEPLATES AND CONNECTORS

END



SECTION 27 05 05

COMMON WORK RESULTS FOR COMMUNICATIONS

PART 1 - GENERAL

1.1 RELATED DOCUMENTS

- A. SECTION 27 05 28 – PATHWAYS FOR COMMUNICATIONS SYSTEMS, this document describes the products and execution requirements relating to furnishing and installing Telecommunications Cabling pathways. Communication cabling support is covered under this document.
- B. SECTION 27 05 26 - GROUNDING AND BONDING FOR COMMUNICATIONS SYSTEMS, this document describes the products and execution requirements relating to furnishing and installing Grounding/Earthing and Bonding for Communications Systems.
- C. SECTION 27 10 70 - COMMUNICATIONS TESTING, IDENTIFICATION AND ADMINISTRATION, this document describes the products and execution requirements relating to testing, labeling, warranties and As-Builts related to Communications Cabling Systems.
- D. SECTION 27 11 16 – COMMUNICATIONS CABINETS AND ENCLOSURES, this document describes the products and execution requirements relating to furnishing and installing Communication Equipment Room Fittings of cabinets, cable management, and telecommunications backboards are covered under this document.
- E. SECTION 27 11 19 – COMMUNICATIONS PATCH PANELS, this document describes the products and execution requirements relating to furnishing and installing Structured Communications Cable System (SCCS) Category 5e and Category 6 patch panels are covered under this document.
- F. SECTION 27 13 23 – COMMUNICATIONS OPTICAL FIBER BACKBONE CABLING, this document describes the products and execution requirements relating to furnishing and installing Telecommunications Cabling Optical fiber backbone cabling and terminations are covered in this document.
- G. SECTION 27 15 00.19 – DATA COMMUNICATIONS HORIZONTAL CABLING, this document describes the products and execution requirements relating to furnishing and installing Horizontal Cabling. Data Communications Horizontal Cabling is covered under this document.
- H. SECTION 27 15 43 - COMMUNICATIONS FACEPLATES AND CONNECTORS, this document describes the products and execution requirements relating to furnishing and installing faceplates, connectors, Category 5e and Category 6 patch cords. Communications faceplates and connectors are covered under this document.

1.2 REFERENCES

- A. The publications listed below form a part of this specification to the extent referenced. The publications are referred to within the text by the basic designation only.
1. Technical Specifications and Associated Drawings.
 2. ANSI/TIA 568-C.0, "Generic Telecommunications Cabling for Customer Premises"
 3. ANSI/TIA 568-C.1, "Commercial Building Telecommunications Cabling Standard"
 4. ANSI/TIA 568-C.2, "Balanced Twisted-Pair Telecommunication Cabling and Components Standard"
 5. ANSI/TIA 568-C.3, "Optical Fiber Cabling Components Standard"
 6. ANSI/TIA-569-A Commercial Building Standard for Telecommunications Pathways and Spaces.
 7. ANSI/TIA -606-A Administration Standard for the Telecommunications Infrastructure of Commercial Buildings.
 8. TIA-607 Commercial Building Grounding and Bonding Requirements for Telecommunications.
 9. Building Industries Consulting Services, International (BICSI) Telecommunications Distribution Methods Manual (TDMM) – 11th edition
 10. National Fire Protection Agency (NFPA) - 70, National Electrical Code (NEC) - 2011
 11. FCC Part 68.5 Establishment of Telephone Premises Wiring Attestation List
 12. ANSI/ICEA S-80-576 (2002) Communication Wire and Cable for Wiring of Premises
 13. NEMA WC 63.1(2005) NEMA Performance Standard For Twisted Pair Premise Voice And Data Communications Cables
 14. REA TECM 823 (1980) Electrical Protection by Use of Gas Tube Arrestors
 15. UL 444 (1994; R 1995, Bul. 1995 and 1996) Communications Cables
 16. UL 467 (1993; Bul. 1994 and 1996, R 1996) Grounding and Bonding Equipment
 17. UL 497 (1995) Safety Protector for Paired Conductor Communication Circuit
 18. UL 514C (1988; R 1989, Bul. 1993 and 1994) Nonmetallic Outlet Boxes, Flush-Device Boxes, and Covers
 19. UL 910 (1995; R 1995, Bul. 1995 and 1996) Flame-Propagation and Smoke-Density Values for Electrical and Optical-Fiber Cables Used in Spaces Transporting Environmental Air

- 20. UL 969 (1995) Marking and Labeling Systems
 - 21. UL 1286 (1993) Office Furnishings
 - 22. UL 1581 (1991; Bul. 1993, 1994, 1995, and 1996, R 1996, R 2003) Electrical Wires, Cables, and Flexible Cords
 - 23. UL 1666(1991; Bul. 1995 and 1996) Flame Propagation Height of Electrical and Optical-Fiber Cables Installed in Vertical Shafts
 - 24. UL 1863 (1995) Communication Circuit Accessories
 - 25. Public Works Standards, Inc. Green Book Standard Specifications For Public Works Construction 2012.
- B. Federal, state, local codes, rules, regulations, ordinances governing the work, as well as LBUSD Structured Telecommunications Cable and Pathway Standards, guidelines and practices may apply and shall be incorporated as part of these specifications.
 - C. In reviewing the various Contract Documents, the Structured Telecommunications Cable Contractor shall be responsible for noting conflicts between proposed design/concepts and the applicable standards, guidelines and practices. A written Request for Information (RFI) shall be developed by the Structured Telecommunications Cable Contractor and submitted to LBUSD prior to commencing any work impacted by such conflicts. Such RFIs shall describe the conflict/violation and, if appropriate, recommend alternative solutions with associated costs. LBUSD warrants that they will diligently strive to address such RFIs in order to minimize negative impact on each SCCS installation completion schedule.
 - D. Where the requirements of the Contract Documents are more stringent than applicable codes, rules, regulations, ordinances, standards, guidelines and practices, the Contract Documents shall apply. In all other instances, the most current standards, guidelines and practices shall apply.

1.2 DEFINITIONS

1.2.1 Main Distribution Frame (MDF)

- A. A physical concentration or central location for terminating backbone cables to interconnect with local exchange carrier (LEC) equipment at the activity minimum point of presence. The MDF generally includes vendor specific components to support voice and data circuits, building surge protector assemblies, main cross connect blocks, equipment support frames, and plywood backboard (if MDF is wall mounted). Depending upon local site conditions, the MDF and IDF may be identical.

1.2.2 Intermediate Distribution Frame (IDF)

- A. An intermediate termination point for horizontal wiring and cross connections normally within another structure separate from the MDF.

1.3 SYSTEM DESCRIPTION

- A. The structured telecommunications cable and pathway distribution and wiring system shall include permanently installed backbone and horizontal cabling, horizontal and backbone pathways, workstation pathways, telecommunications outlet assemblies, conduit, raceway, and hardware for terminating, and interconnecting.

- B. The horizontal system includes the cabling and pathway between the MDF and/or IDFs and the work area telecommunications outlet.
- C. The backbone cabling and pathway system includes the interconnecting cabling, pathway, and terminal hardware to provide connectivity between the MDF's, and IDF's.
- D. The backbone system shall be wired in a star topology with the MDF at the center or hub of the star.
- E. For new cabling additions to existing structured communications cable system installations, Contractor shall provide and install Commscope Systimax or AMP Netconnect. Final selection of manufacturer shall be decided and approved by LBUSD.
- F. Horizontal station cable and terminating equipment shall consist of UL approved:
 - 1. Category 5e for moves, adds and changes to existing structured communications cable systems.
 - 2. Category 6 for installation in new buildings.
 - 3. All horizontal station cable shall be plenum rated and U.L. CMP listed.
- G. Wireless Network – 802.11:
 - 1. All wireless devices shall be cabled with Category 6, plenum rated cable.
 - 2. All wireless Category 6 cable, patch panel, jacks, faceplates and patch cords shall be AMP Netconnect or CommScope Systimax.
 - 3. If MDF and/or IDF does not have adequate capacity to support additional cable and termination hardware, Contractor shall provide and install new IDF to support wireless networks.
- H. All new fiber optic cable and fiber optic termination hardware shall be manufactured by Corning.
- I. All indoor/outdoor rated fiber optic cable shall be plenum rated and U.L. OFNP listed.
- J. All Multimode fiber optic backbone cable shall not exceed a maximum distance of 500 meters.
- K. New fiber optic backbone cable extending from MDF shall consist of indoor/outdoor plenum rated Multimode laser-optimized OM3, 50/125µm fiber optic cable.
- L. When extending from existing campus IDF, new fiber optic backbone cable shall consist of indoor/outdoor plenum rated Multimode 62.5/125µm fiber optic cable.
- M. Fiber optic backbone cable exceeding 500 meters shall consist of indoor/outdoor plenum rated Singlemode fiber optic cable.
- N. Inter-building backbone pathways will consist of new conduits, trade size 2" minimum, existing conduits or a combination of both, as per the drawings and other construction documents.

- O. Horizontal pathways will consist of new conduits, trade size 2" minimum, existing conduit, J-Hooks, Cable Tray and surface mounted Wiremold 5500 raceway or combination of all and as per drawings and other construction documents.
- P. J-Hooks shall be used when cable routes are visible and not concealed by walls or ceilings.
- Q. Structured Telecommunications Cabling and Pathways Systems shall be installed in a "neat and workmanlike manner" as specified by ANSI/NECA/BICSI 568-2001, 569-A and National Electrical Code, Sections 110-12 and 800-6.

1.4 SUBMITTALS

- A. Provide BICSI RCDD registration number at time of bid.
- B. Provide copy of contractor's manufacturer certification at time of bid.
- C. Contractor is to submit the following prior to construction for District approval:

1.4.1 Manufacturer's Catalog Data

- A. Telecommunications cabling (backbone and horizontal)
- B. Fiber optic type SC connectors
- C. Telecommunications outlet/connector assemblies RJ-45 jack
- D. Equipment racks
- E. Equipment cabinets
- F. Patch Panels (Copper and Fiber optic)
- G. Power Strips
- H. Cable Hangers
- I. Floor outlet boxes or modules
- J. Firestop material
- K. Non-Metallic surface mounted raceway
- L. Cable tray
- M. Conduits
- N. Outlet boxes
- O. Pull boxes
- P. Underground pull boxes
- Q. NEMA rated junction boxes

1.4.2 Drawings

- A. Telecommunications Shop and As-Built Drawings
- B. MDF/IDF Equipment Cabinet and/or Rack Elevation Shop and As-Built Drawings

1.4.2.1 Telecommunications Shop Drawings and As-built Drawings

- A. Provide BICSI registered communications distribution designer (RCDD) approved drawings complete with wiring diagrams and details required to prove that the distribution system shall properly support connectivity from the MDF to the IDF to the telecommunications work area outlets.
- B. Show the layout of all cabling and pathway runs, MDF, IDF and ground system.
- C. Drawings shall depict all final telecommunications cabling configurations, including locations, gage, pair assignments and patch panels after completed telecommunications cable installation.
- D. Shop and As-Built drawings shall depict LBUSD approved structured communications cable system identifications and administration labeling scheme.
- E. As-Built drawings shall depict all final telecommunications cabling configurations, including locations, cable counts and IDF locations after completed telecommunications cable installation.
- F. Electronic copies of campus as-built drawings will be provided to the Structured Telecommunications Cable Contractor, if they exist. If no drawings exist, the Structured Telecommunications Cable Contractor shall create new CAD drawings for that campus.
- G. Work added to an existing campus will be included on as-built drawings. Added work will be clouded on the drawing and appropriate notes shall be added to the legend and title block, indicating scope of work, contractor name and date of completion.
- H. For each campus, provide one (1) plastic laminated schematic of telecommunications cable system showing cabling, IDF's, MDF's, and equipment rooms keyed to floor plans by room number.
- I. For each campus, provide two (2) electronic copies of As-Builds to LBUSD.

1.4.2.2 MDF/IDF Equipment Cabinet and/or Rack Elevation Shop and As-Built Drawings

- A. Provide shop drawing showing layouts and elevations of all applicable equipment including MDF and/or IDF cabinets, racks, cable runway, patch panels, cable management and LAN equipment.
- B. Prior to installation, contractor shall provide written documentation that details cabinet wall mounting and anchoring methods anticipated for each installation.

1.4.3 Statements

- A. Installer qualifications
- B. Test plan

- C. Professional References
- D. Factory Test Reports
- E. Field Test Reports
- F. Operations and Maintenance Manuals
- G. Schedules
- H. Labeling Scheme

1.4.3.1 Installer Qualifications

- A. Prior to installation, submit data of installer's experience and qualifications, which shall include 3 years on projects of similar complexity. Include names and locations of two projects successfully completed using fiber optic and copper communications cabling systems in similar environments.
- B. Contractor's installers shall be manufacturer trained and certified. Contractor shall provide copies of manufacturer's certificates at time of bid.
- C. Include specific experience in installing and testing structured telecommunications distribution systems using fiber optic and Category 6 or higher, cabling systems.

1.4.3.3 Professional References

- A. Provide a list of at least five professional references for similar projects. Include Company names, Contacts, phone numbers and a description of project.

1.4.5 Cable Certification Test Results

- A. Contractor shall provide performance certification cable test results.
- B. Contractor shall comply with testing requirements specified in section 27 10 70 COMMUNICATIONS TESTING, IDENTIFICATION AND ADMINISTRATION.
- C. Electronic copies of Certification Test Results shall be provided to LBUSD within ten days of cable installation completion.
- D. Electronic copies of Certification Test Results shall be provided to LBUSD in PDF and native format.

1.4.7 Schedules

- A. Construction Schedules are required for each project.
- B. Construction schedules shall be managed by General Contractor and/or Structured Communications Cable System installation Contractor.

1.4.8 Labeling

- A. Labeling scheme must comply with TIA 606 standards.
- B. Contractor must coordinate with the District prior to installing any permanent labels.

- C. Contractor shall comply with labeling requirements specified in section 27 10 70 COMMUNICATIONS TESTING, IDENTIFICATION AND ADMINISTRATION.

1.5 SYSTEM CERTIFICATION AND/OR WARRANTY

- A. The installation must be certified to meet the latest available manufacturer system warranty program requirements for an extended warranty of twenty (20) years minimum duration. At minimum such warranty shall, at no additional cost to LBUSD, provide a system warranty covering the installed Structured Communications Cable System (SCCS) against defects in workmanship, components and performance. At minimum, the contractors qualifications for manufacturer's certification shall include:
 - 1. For moves, adds and changes to existing installed structured communications cable systems, contractor shall be certified by same manufacturer as existing system. For Systimax, contractor shall be Systimax certified, for AMP Netconnect, contractor shall be AMP NDI certified.
 - 2. SCCS Contractor shall have valid Manufacturer Certification for the entire project duration of the installation agreement. In addition the SCCS Contractor shall have no known pending action or intent by Manufacturer to terminate or limit the SCCS Contractor status as a Manufacturer Certified installer.
 - 3. SCCS Contractor shall attach to bid response a copy of their current Manufacturer Certification certificate demonstrating valid certification in the Southern California region. The attached certificate is to specifically cite the name of proposing SCCS contractor.
- B. SCCS Contractor shall provide installation warranty protecting LBUSD against defects in workmanship for a minimum period of two years from the date of system acceptance. Such warranty shall provide all labor and materials necessary to correct a failed portion of the system and to demonstrate performance within original specifications after the repairs are accomplished.
- C. A system component and performance warranty extended by manufacturer for a period of not less than twenty (20) years from date of system acceptance. The performance warranty shall warrant the installed horizontal and backbone copper portion of the system and, as applicable, the installed horizontal and backbone fiber optic portions of the system. All such links and segments shall be warranted in accordance with the latest applicable requirements as defined by TIA.
- D. As outlined herein, LBUSD intends that the resulting Structured Telecommunications Cable System be warranted under the extended warranty provisions extended by CommScope Systimax, AMP Netconnect, and Corning. The Technical Specification is based on the products being manufactured by Systimax, AMP Netconnect and others. The warranty shall extend to the fiber optic, Category 5e and Category 6 UTP portions of the installation to the fullest extent allowed by the manufacturers.

1.6 COORDINATION AND SUPPORT

- A. Coordinate layout and installation of voice, data, and video communication cabling with other LBUSD contractors and equipment suppliers.

- B. Structured Telecommunications Cable Contractor shall attend weekly project meetings.
- C. Meet jointly with other contractors, equipment suppliers, LBUSD in order to exchange information and agree on details of equipment arrangements and installation interfaces.
- D. Record agreements reached in meetings and distribute to other participants in a timely manner.
- E. Adjust arrangements and locations of distribution frames, cross-connect and patch panels in equipment rooms and/or telecommunications rooms to accommodate and/or optimize the arrangement and space requirements of voice and LAN equipment.
- F. Provide weekly progress reports and weekly crew schedules to LBUSD by 5:00 PM Thursday of each project work week.

1.7 DELIVERY AND STORAGE

- A. Contractor shall provide secure storage with protection from weather, moisture, dirt, dust and other contaminants for all telecommunications cabling and pathway material and equipment.

PART 2 - PRODUCTS – NOT USED

PART 3 - EXECUTION – NOT USED

END



SECTION 27 05 26

GROUNDING AND BONDING FOR COMMUNICATIONS SYSTEMS

PART 1 - GENERAL

1.1 RELATED DOCUMENTS

- A. SECTION 27 05 05 - COMMON WORK RESULTS FOR COMMUNICATIONS, this document describes the LBUSD products, execution, qualifications, manufacturer warranties, and coordination requirements relating to furnishing and installing a complete, turn-key Communications Cabling System.
- B. SECTION 27 05 28 – PATHWAYS FOR COMMUNICATIONS SYSTEMS, this document describes the products and execution requirements relating to furnishing and installing Telecommunications Cabling pathways. Communication cabling support is covered under this document.
- C. SECTION 27 10 70 - COMMUNICATIONS TESTING, IDENTIFICATION AND ADMINISTRATION, this document describes the products and execution requirements relating to testing, labeling, warranties and As-Builts related to Communications Cabling Systems.
- D. SECTION 27 11 16 – COMMUNICATIONS CABINETS AND ENCLOSURES, this document describes the products and execution requirements relating to furnishing and installing Communication Equipment Room Fittings of cabinets, cable management, and telecommunications backboards are covered under this document.
- E. SECTION 27 11 19 – COMMUNICATIONS PATCH PANELS, this document describes the products and execution requirements relating to furnishing and installing Structured Communications Cable System (SCCS) Category 5e and Category 6 patch panels are covered under this document.
- F. SECTION 27 13 23 – COMMUNICATIONS OPTICAL FIBER BACKBONE CABLING, this document describes the products and execution requirements relating to furnishing and installing Telecommunications Cabling Optical fiber backbone cabling and terminations are covered in this document.
- G. SECTION 27 15 00.19 – DATA COMMUNICATIONS HORIZONTAL CABLING, this document describes the products and execution requirements relating to furnishing and installing Horizontal Cabling. Data Communications Horizontal Cabling is covered under this document.
- H. SECTION 27 15 43 - COMMUNICATIONS FACEPLATES AND CONNECTORS, this document describes the products and execution requirements relating to furnishing and installing faceplates, connectors, Category 5e and Category 6 patch cords. Communications faceplates and connectors are covered under this document.

1.2 WORK INCLUDED

- A. Provide all labor, materials, tools and equipment required for the complete installation of work called for in the Construction Documents

1.3 SCOPE OF WORK

- A. This document describes the products and execution requirements relating to furnishing and installing Grounding/Earthing and Bonding for Communications Systems.
- B. This section includes minimum requirements for the following:
 - Grounding/Earthing System
 - Telecommunications Grounding Busbar (TGB)
 - Telecommunications Main Grounding Busbar (TMGB)
 - Telecommunications Bonding Backbone (TBB)
 - Rack Grounding/Earthing and Bonding
- C. All cables and related terminations, support and grounding/earthing hardware shall be furnished, installed, wired, tested, labeled, and documented by the telecommunications contractor as detailed in this document.
- D. Product specifications, general design considerations, and installation guidelines are provided in this document. Quantities grounding/earthing products, typical installation details and cable routing will be provided as an attachment to this document. If the bid documents are in conflict, this specification shall take precedence. The successful vendor shall meet or exceed all requirements for the cable system described in this document.

1.4 REGULATORY REFERENCES

- A. The following industry standards are the basis for the grounding/earthing and bonding system described in this document.
 - 1. TIA/EIA
 - TIA-942 Telecommunications Infrastructure Standard for Data Centers
 - J-STD-607-B Commercial Building Grounding/Bonding Requirements
 - TIA/EIA-606 Administration Standard for the Telecommunications Infrastructure of Commercial Buildings
 - 2. IEEE
 - Std 1100 IEEE Recommend Practice for Powering and Grounding Electronic Equipment (IEEE Emerald Book)
 - 3. NFPA
 - NFPA-70 National Electric Code (NEC)
- B. Federal, state, local codes, rules, regulations, ordinances governing the work, as well as LBUSD Structured Telecommunications Cable and Pathway Standards, guidelines and practices may apply and shall be incorporated as part of these specifications.
- C. In reviewing the various Contract Documents, the Structured Telecommunications Cable Contractor shall be responsible for noting conflicts between proposed design/concepts and the applicable standards, guidelines and practices. A written Request for Information (RFI) shall be developed by the Structured Telecommunications Cable Contractor and submitted to LBUSD prior to commencing any work impacted by such conflicts. Such RFIs shall describe the conflict/violation and, if appropriate, recommend alternative solutions with associated costs. LBUSD

warrants that they will diligently strive to address such RFIs in order to minimize negative impact on each SCCS installation completion schedule.

- D. Where the requirements of the Contract Documents are more stringent than applicable codes, rules, regulations, ordinances, standards, guidelines and practices, the Contract Documents shall apply. In all other instances, the most current standards, guidelines and practices shall apply.

1.5 QUALITY ASSURANCE

- A. See the Panduit Electrical Product Warranty on www.panduit.com/warranty

1.6 APPROVED PRODUCTS

- A. Approved grounding/earthing system manufacturer: *PANDUIT*
- B. Approved telecommunications grounding busbar manufacturer: *PANDUIT*
- C. Approved rack grounding kit manufacturer: *PANDUIT*
- D. Approved retrofit rack grounding kit manufacturer: *PANDUIT*

1.7 DEFINITIONS

- A. Bonding – The permanent joining of metallic parts to form an electrically conductive path that will assure electrical continuity and the capacity to conduct safely any current likely to be imposed.
- B. Common Bonding Network (CBN) – The principal means for affecting bonding and earthing inside a building.
- C. Ground/Earth – A conducting connection, whether intentional or incidental, by which an electric circuit or equipment is connected to earth, or to some conducting body of relatively large extent that serves in place of the earth.
- D. Retrofit Rack Grounding/Earthing – The application of grounding/earthing products and technology where equipment is already deployed and functioning.

1.8 OVERVIEW

- A. The purpose of the grounding/earthing system is to create a low impedance path to earth ground for electrical surges and transient voltages. Lightning, fault currents, circuit switching (motors turning on and off), and electrostatic discharge are common causes of these surges and transient voltages. An effective grounding/earthing system minimizes the detrimental effects of these electrical surges, which include degraded network performance and reliability and increased safety risks.
- B. The grounding/earthing system must be intentional, visually verifiable, adequately sized to handle expected currents safely, and directs these potentially damaging currents away from sensitive network equipment. As such, grounding/earthing must be purposeful in its design and installation. Four issues require special consideration:
 - 1. Although AC powered equipment typically has a power cord that contains a ground/earth wire, the integrity of this path cannot be easily verified. Thus, many equipment manufacturers require grounding/earthing above and beyond that which is specified by local electrical codes, such as the National Electrical Code, etcetera. Always follow the grounding/earthing recommendations of the manufacturer when installing equipment.

2. While the building steel and metallic water piping must be bonded to the grounding/earthing system for safety reasons, neither may be substituted for the telecommunications bonding backbone (TBB).
3. Electrical continuity throughout each rack or cabinet is required to minimize safety risks. Hardware typically supplied with bolt-together racks is not designed for grounding/earthing purposes. Additionally, most racks are painted. Paint is an insulator. Unless rack members are deliberately bonded, continuity between members is incidental, and in many cases, unlikely.
4. Any metallic component that is part of the data center, including equipment, racks, ladder racks, enclosures, cable trays, etc. must be bonded to the grounding/earthing system.

1.9 WORKMANSHIP

- A. The ground/earth system must be designed for high reliability. Therefore, the grounding/earthing system shall meet following criteria:
 1. Local electrical codes shall be adhered to.
 2. The grounding/earthing system shall comply with ANSI/TIA-942 and J-STD-607-A.
 3. All grounding/earthing conductors shall be copper.
 4. Lugs, HTAPs, grounding strips, and busbars shall be UL Listed and made of premium quality tin-plated electrolytic copper that provides low electrical resistance while inhibiting corrosion. Antioxidant shall be used when making bonding connections in the field.
 5. Wherever possible, two-hole lugs shall be used because they resist loosening when twisted (bumped) or exposed to vibration. All lugs shall be irreversible compression and meet NEBS Level 3 as tested by Telcordia. Lugs with inspection windows shall be used in all non-corrosive environments so that connections may be inspected for full conductor insertion (battery rooms are an exception where windowless lugs may be used).
 6. Die index numbers shall be embossed on all compression connections to allow crimp inspection.
 7. Cable assemblies shall be UL Listed and CSA Certified. Cables shall be a distinctive green or green/yellow in color, and all jackets shall be UL, VW-1 flame rated.

PART 2 - PRODUCTS

2.1 EQUIVALENT PRODUCTS

- A. *PANDUIT* shall manufacture all products related to grounding/earthing and bonding for communications systems. There will be no substitutions allowed.

2.2 GROUNDING/EARTHING AND BONDING

- A. The Telecommunications Grounding Busbar (TGB) in each telecommunications space will be grounded/earthed to the Telecommunications Main Grounding Busbar

(TMGB) located at the service entrance. The gauge of the connecting ground/earth cable, known as the Telecommunications Bonding Backbone (TBB) will follow J-STD-607-A guidelines, as is shown in the table below.

Sizing of the TBB	
TBB Length in Linear meters (feet)	TBB Size (AWG)
Less than 4 (13)	6
4-6 (14-20)	4
6-8 (21-26)	3
8-10 (27-33)	2
10-13 (34-41)	1
13-16 (42-52)	1/0
16-20 (53-66)	2/0
Greater than 20 (66)	3/0

- B. The TMGB will be bonded to building steel and grounded/earthed to the electrical service ground according to BICSI TDM Manual and J-STD-607-B guidelines. Local codes may supersede these requirements. In telecommunications spaces with only one rack, the rack jumper cable can be connected directly to the TGB.

Cable Sizes for Other Grounding/Earthing Applications	
Purpose	Copper Code Cable Size
Aisle grounds (overhead or under floor) of the common bonding network	#2 AWG or larger (1/0 preferred)
Bonding conductor to each PDU or panel board serving the room.	Size per NEC 250.122 & manufacturer recommendations
Bonding conductor to HVAC equipment	6 AWG
Building columns	4 AWG
Cable ladders and trays	6 AWG
Conduit, water pipe, duct	6 AWG

2.3 COMPONENTS, KITS AND HARDWARE

- A. PANDUIT® StructuredGround™ Grounding System (StructuredEarth™ Earthing System) kits, components, and hardware shall be used to construct the grounding/earthing system.
- B. Use PANDUIT GB4 series BICSI/J-STD-607-A telecommunications grounding busbars for the TMGB, which is ideally located at the AC service entrance. Use a PANDUIT GB2 series busbar for the TGB in each of the other telecommunications/equipment spaces throughout the building. Use PANDUIT LCC-W series lugs when connecting conductors to the TMGB and TGB.
- C. Route the TBB to each TGB in as straight a path as possible. The TBB should be installed as a continuous conductor, avoiding splices where possible. Use PANDUIT HTAP kits, family HTWC, to provide a tap from the TBB to each TGB. When more than one TBB is used, bond them together using the TGBs on the top floor and every third floor in between with a conductor known as a Grounding Equalizer (GE). Use the J-STD-607-A guidelines for sizing of the TBB when sizing the GE (shown in the table above).
- D. Avoid routing grounding/earthing conductors in metal conduits. If the grounding/earthing conductor must be routed through a metal conduit, bond each end of the conduit to the grounding/earthing conductor. Use PANDUIT GPL series grounding clamps to bond to the conduit, a PANDUIT HTWC HTAP with clear cover

to bond to the grounding/earthing conductor, and a #6 AWG copper conductor to connect the GPL grounding clamp to the HTWC HTAP.

2.4 RACK GROUNDING/EARTHING

- A. Equipment and racks shall be bonded in accordance with the methods prescribed in ANSI/TIA-942, as is shown in the figure below.

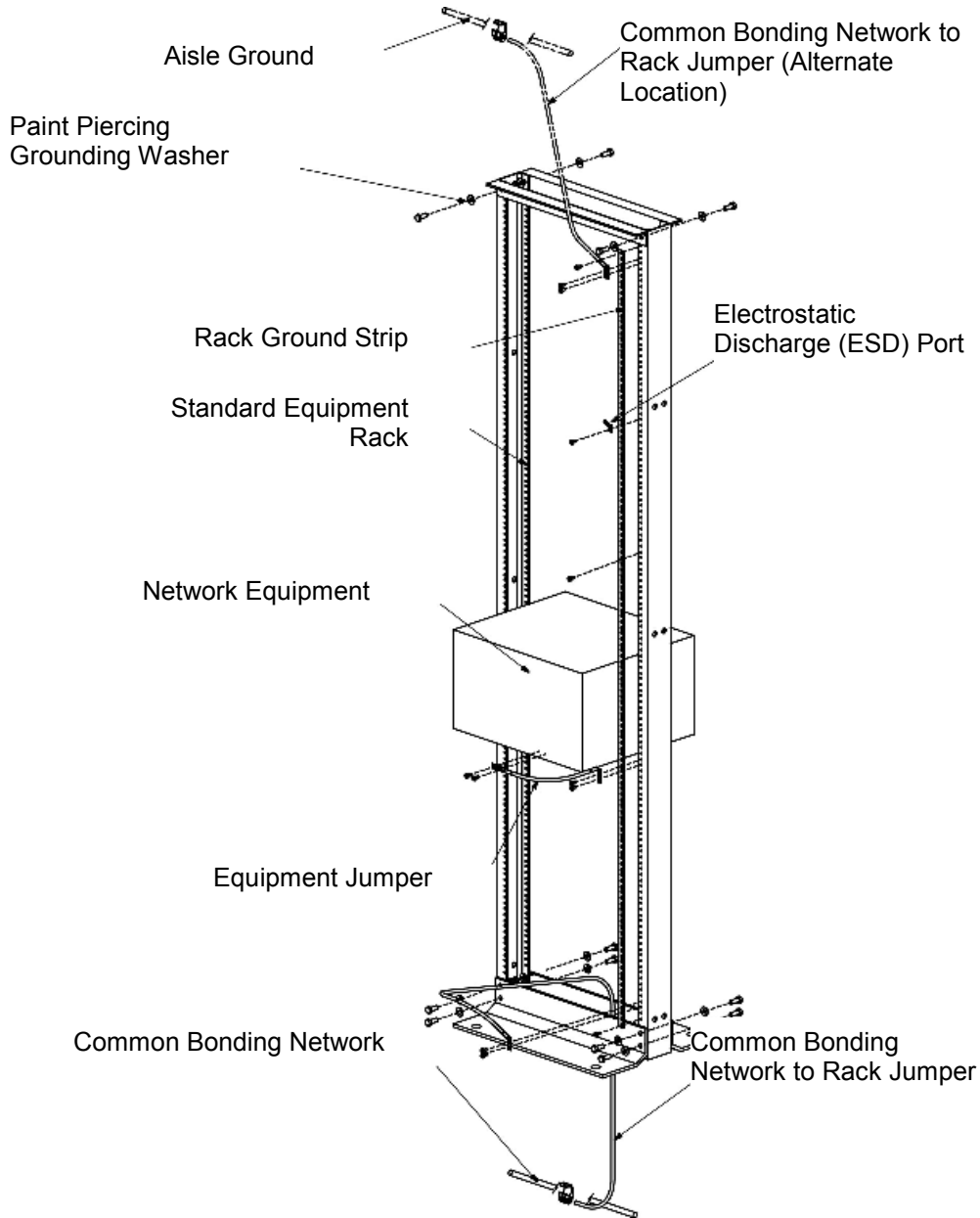

Figure 1 - Properly Grounded/Earthed Rack (Back of Rack Shown)

- B. To provide electrical continuity between rack elements, *PANDUIT* paint piercing grounding washers, series RGW, shall be used where rack sections bolt together, on both sides, under the head of the bolt and between the nut and rack.

- C. All racks shall utilize a full-length rack ground strip, *PANDUIT* part number RGS134, attached to the rear of the side rail with the thread-forming screws provided to ensure metal-to-metal contact.
- D. Mount an electrostatic discharge (ESD) port kit, *PANDUIT* part number RGEDS-1 directly to the rack grounding strip on the back of the rack at approximately 48 inches from the floor. Mount a second RGEDS-1 directly to the vertical mounting rail of the rack in the front at approximately the same height. Use the thread-forming screws provided to form a bond to the rack. Place the ESD protection identification stickers directly above the ESD ports.
- E. When the equipment manufacturer provides a location for mounting a grounding connection, that connection shall be utilized. Use the appropriate *PANDUIT* RG series jumper for the equipment being installed and the thread-forming screws provided in the kit.
- F. Use *PANDUIT* part number RGCBNJ660P (common bonding network to rack jumper) to attach the rack ground strip to the common bonding network. Do not bond racks or cabinets serially. Use the copper compression HTAP that comes with the kit to bond the conductor to the common bonding network.
- G. Patch panels will be bonded to racks using the *PANDUIT* bonding screws, part number RGTBS-C for racks having #12-24 equipment mounting holes, and RGTBSM6-C for racks having M6 equipment mounting holes.

2.5 RETROFIT RACK GROUNDING/EARTHING

- A. If the racks already have network equipment installed, it may not be feasible to install the rack ground strip without disrupting data cables. Further, it may be undesirable to disassemble rack hardware to install paint piercing grounding washers. In these circumstances, the *PANDUIT* retrofit rack grounding kits, *PANDUIT* part family RGR, are to be installed.
- B. For retrofit rack grounding/earthing installations, use *PANDUIT* part number RGRKCBNJ to ground/earth the rack to the common bonding network. Use *PANDUIT* part number RGEJ696 (provided with #6 AWG grounding conductor) or *PANDUIT* part number RGEJ1096 (provided with #10 AWG grounding conductor) to ground/earth equipment chassis to the rack grounding busbar provided with the RGRKCBNJ as is shown in the figure below.

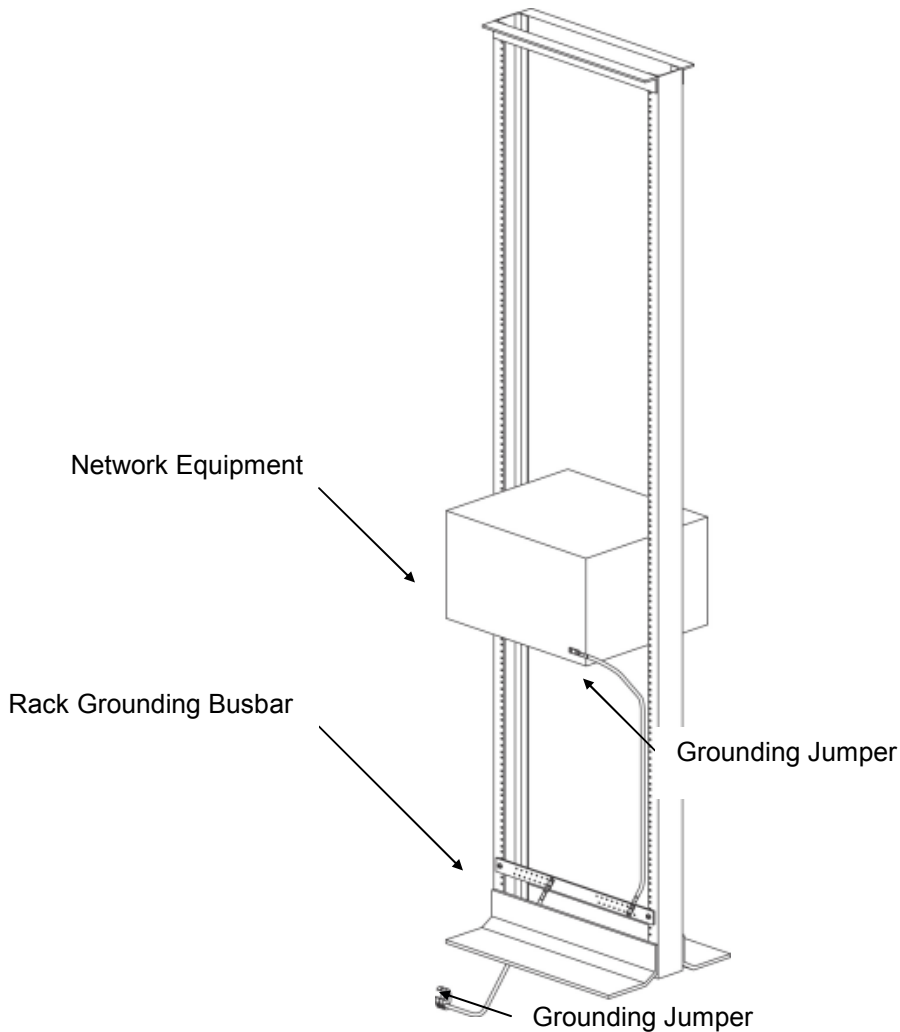

Figure 2 - Retrofit Rack Grounding/Earthing

- C. RGW paint piercing grounding washers are not used in this scenario. Thus, the grounding busbar provides continuity through the vertical channels of the rack, but not the top and bottom of the rack. Thus, wherever practical, the solution using the RGS rack grounding strip and the RGW paint piercing washers shall be used instead of the retrofit rack grounding kits.
- D. All other grounding/earthing requirements apply to retrofit installations without exception.
- E. Use *PANDUIT® STRUCTUREDGROUND™* Grounding System (*STRUCTURED EARTH™* Earthing System) in every application possible. See <http://www.panduit.com> for the latest grounding and bonding solutions.

PART 3 - EXECUTION

3.1 GROUNDING SYSTEM

The communications grounding system shall be designed and/or approved by a qualified PE, or RCDD. The communications grounding system shall adhere to the recommendations of

the ANSI/TIA-942 and J-STD-607-B standards, and shall be installed in accordance with best industry practice.

A licensed electrical contractor shall perform installation and termination of the main bonding conductor to the building service entrance ground.

END OF SECTION



SECTION 27 05 28

PATHWAYS FOR EXISTING COMMUNICATIONS SYSTEMS

PART 1 - GENERAL

1.1 RELATED DOCUMENTS

- A. SECTION 27 05 05 - COMMON WORK RESULTS FOR COMMUNICATIONS, this document describes the LBUSD products, execution, qualifications, manufacturer warranties, and coordination requirements relating to furnishing and installing a complete, turn-key Communications Cabling System.
- B. SECTION 27 05 26 - GROUNDING AND BONDING FOR COMMUNICATIONS SYSTEMS, this document describes the products and execution requirements relating to furnishing and installing Grounding/Earthing and Bonding for Communications Systems.
- C. SECTION 27 10 70 - COMMUNICATIONS TESTING, IDENTIFICATION AND ADMINISTRATION, this document describes the products and execution requirements relating to testing, labeling, warranties and As-Builts related to Communications Cabling Systems.
- D. SECTION 27 11 19 – COMMUNICATIONS PATCH PANELS, this document describes the products and execution requirements relating to furnishing and installing Structured Communications Cable System (SCCS) Category 5e and Category 6 patch panels are covered under this document.
- E. SECTION 27 15 00.19 – DATA COMMUNICATIONS HORIZONTAL CABLING, this document describes the products and execution requirements relating to furnishing and installing Horizontal Cabling. Data Communications Horizontal Cabling is covered under this document.
- F. SECTION 27 15 43 - COMMUNICATIONS FACEPLATES AND CONNECTORS, this document describes the products and execution requirements relating to furnishing and installing faceplates, connectors, Category 5e and Category 6 patch cords. Communications faceplates and connectors are covered under this document.

1.2 WORK INCLUDED

- A. Provide all labor, materials, tools and equipment required for the complete installation of work called for in the Construction Documents

1.3 SCOPE OF WORK

- A. This document describes the products and execution requirements relating to furnishing and installing Telecommunications Cabling pathways. Communication cabling support is covered under this document.

- B. This section includes minimum requirements for the following:
 - 1. Non-Continuous Cable Support
 - 2. Surface Mount Raceway
 - 3. Cable Management Waterfall
 - 4. Threaded Rod Covers
 - 5. Underground Pull Boxes
 - 6. Pull Boxes
 - 7. Communications Dust Banks and Conduit
- C. All cables and related terminations, support and grounding hardware shall be furnished, installed, wired, tested, labeled, and documented by the telecommunications contractor as detailed in this document.
- D. Product specifications, general design considerations, and installation guidelines are provided in this document. Quantities of telecommunications outlets, typical installation details, cable routing and outlet types will be provided as an attachment to this document. If the bid documents are in conflict, this specification shall take precedence. The successful vendor shall meet or exceed all requirements for the cable system described in this document.

1.4 REGULATORY REFERENCES

- A. The following industry standards are the basis for the structured cabling system described in this document.
 - 1. TIA/EIA
 - TIA/EIA-568-B Commercial Building Telecommunications Cabling Standard
 - TIA/EIA-569-A Commercial Building Standard for Telecom Pathways And Spaces
 - TIA/EIA-606 Administration Standard for the Telecommunications Infrastructure of Commercial Buildings
 - TIA/EIA-607 Commercial Building Grounding/Bonding Requirements
 - 2. NFPA
 - NFPA-70 National Electric Code (NEC)-1999
 - 3. ISO/IEC
 - ISO/IEC 11801 Generic Cabling for Customer Premises
 - 4. PUBLIC WORKS STANDARDS, INC.
 - GREENBOOK; Green Book Standard Specifications for Public Works Construction 2012.
- B. Federal, state, local codes, rules, regulations, ordinances governing the work, as well as LBUSD Structured Telecommunications Cable and Pathway Standards, guidelines and practices may apply and shall be incorporated as part of these specifications.

- C. In reviewing the various Contract Documents, the Structured Telecommunications Cable Contractor shall be responsible for noting conflicts between proposed design/concepts and the applicable standards, guidelines and practices. A written Request for Information (RFI) shall be developed by the Structured Telecommunications Cable Contractor and submitted to LBUSD prior to commencing any work impacted by such conflicts. Such RFIs shall describe the conflict/violation and, if appropriate, recommend alternative solutions with associated costs. LBUSD warrants that they will diligently strive to address such RFIs in order to minimize negative impact on each SCCS installation completion schedule.
- D. Where the requirements of the Contract Documents are more stringent than applicable codes, rules, regulations, ordinances, standards, guidelines and practices, the Contract Documents shall apply. In all other instances, the most current standards, guidelines and practices shall apply.

1.5 QUALITY ASSURANCE

- A. Structured Communications Cabling System pathways, raceways and supports shall be installed per the following:
 - 1. Meet all NEC, CEC, TIA and BICSI commercial building wiring standards.
- B. All Networks shall be installed per applicable standards and manufacturer's guidelines.

1.5 PATHWAY INSTALLATIONS

- A. Comply with TIA/EIA-569-A, NEC and CEC.
- B. Shall be installed in accordance with NEC Article 314 and Article 800.51 (J), (K), or (L), as applicable, and installed in accordance with Articles 362.24 through 362.56, where the requirements applicable to electrical nonmetallic tubing apply.
- C. Conceal interior conduit under floor slabs and within finished walls, ceilings, and floors where possible.
- D. Keep conduit minimum 6 inches away from parallel runs of electrical power equipment, flues, steam, and hot water pipes.
- E. Install conduit parallel with or at right angles to ceilings, walls, and structural members where located above accessible ceilings and where conduit is visible after completion of project.
- F. Run conduits in crawl spaces and under floor slabs as if cable is exposed.
- G. Install no more than two 90-degree bends for a single horizontal cable run.
- H. Run conduits and surface mounted raceway as determined by site survey or as noted on drawings.
- I. Provide Pullboxes with "Sealtight" flex conduit only where flexible connections are required. LBUSD approval required prior to all "Sealtight" flex conduit installations.

- J. Provide all coring, patching and painting as needed for Intra-Building and Inter-Building pathways. Caulking is not an acceptable patching method for conduit penetrations into exterior walls. Coordinate with LBUSD for acceptable patching methods.

PART 2 - PRODUCTS

2.1 NON-METALLIC SURFACE MOUNTED RACEWAY

- A. Conceal cable pathways within walls whenever possible.
- B. Unless otherwise indicated, raceway shall be three channel, Wiremold 5500 with all necessary brackets, adapters, hardware and equipment to install manufacturer certified Structured Communications Cable Systems.
- C. Raceway shall be ivory in color or as noted on drawings.
- D. Notching or modifications of raceway will not be permitted.
- E. Proper screws and anchors shall be used to mount raceway.
- F. Manufacturer: Wiremold.

2.2 NON-CONTINUOUS CABLE SUPPORT

- A. Material
 - 1. Contractor shall provide and install all non-continuous cable supporting hardware.
 - 2. Non-continuous cable supporting hardware consists of J-hooks, multi-function clips, beam clamps, etc. Bridle rings are not permitted.
 - 3. Non-continuous cable supports shall provide a load bearing surface of sufficient width to comply with required bend radii of high-performance cables; UL Listed. Bridle rings are not permitted.
 - 4. Non-continuous cable supports shall have flared edges to prevent damage while installing cables.
 - 5. Non-continuous cable supports sized 1 5/16" and larger shall have a cable retainer strap to provide containment of cables within the hanger. The cable retainer strap shall be removable and reusable and be suitable for use in air handling spaces.
 - 6. Non-continuous cable supports shall have an electro-galvanized or G60 finish and shall be rated for indoor use in non-corrosive environments.
 - 7. Multi-tiered non-continuous cable support assemblies shall be used where separate cabling compartments are required. Assemblies may be factory assembled or assembled from pre-packaged kits. Assemblies shall consist of a steel angled hanger bracket holding up to six non-continuous cable supports, rated for indoor use in non-corrosive environments; UL Listed.
 - 8. If required, the multi-tier support bracket may be assembled to manufacturer recommended specialty fasteners including beam clamps, flange clips, C and Z purlin clips, etc.

9. Tee-bar support bracket with one non-continuous cable support, factory or jobsite assembled; rated for indoor use in non-corrosive environments; UL Listed.
 10. Fastener to wire/rod with one non-continuous cable support, factory or jobsite assembled; rated for indoor use in non-corrosive environments; UL Listed.
 11. Fastener to beam or flange with one non-continuous cable support, factory or jobsite assembled; rated for indoor use in non-corrosive environments; UL Listed.
 12. Fastener to C or Z purlin with one non-continuous cable support, factory or jobsite assembled; rated for indoor use in non-corrosive environments, UL Listed.
 13. Fastener to wall, concrete, or joist with one non-continuous cable support, factory or jobsite assembled; rated for indoor use in non-corrosive environments, UL Listed.
 14. Fastener to threaded rod with one non-continuous cable support, factory or jobsite assembled, rated for indoor use in non-corrosive environments, UL Listed.
 15. The multi-tiered support bracket shall have a static load limit of 300 lbs.
 16. U-hooks and double J-hooks shall attach directly to threaded rod using standard nuts.
- B. Manufacturer: Panduit, Copper B-Line, or LBUSD approved equal.

2.3 THREADED ROD COVER

- A. The Threaded Rod Cover shall be utilized to protect communication cable from abrasion caused by contact with threaded rod. The Threaded Rod Cover shall be manufactured from a gray flame-retardant polyethylene material that is UL94V-0 rated. The material shall be pliable to allow for easy installation.
- B. Manufacturer: Panduit or LBUSD approved equal.

Part Number	For Threaded Rod Size	Length
TRC18FR-X8	1/2" to 5/8"	18"

2.4 UNDERGROUND PULL BOXES AND PULLBOXES

- A. Underground pull boxes shall be made of concrete and the minimum size shall be 35 1/2" x 17 1/2" x 12".
- B. Underground pull covers shall be rated for traffic (type T.05) and shall be marked communications.
- C. Metal covers shall be used in all location subject to vehicle traffic.
- D. Gravel shall be installed below all ground boxes for drainage.
- E. Ground boxes and pull boxes shall not be placed in areas subject to flooding.
- F. Establish drainage to meet Public Works Construction Standards (Green Book).

- G. Unless otherwise noted, pull boxes shall have minimum dimensions of 20" x 20" x 6".
1. Interior pull boxes shall consist of 16 gauge steel minimum, unless otherwise noted on plans.
 2. Indoor enclosures shall conform to NEMA Type 4, unless otherwise noted.
 3. Size pull boxes to not less than minimum Code requirements. Increase size above Code requirements where necessary to provide space for pulling, racking or splicing enclosed conductors, or where specified or indicated dimensions exceed Code requirements.
 4. Exterior metal pull boxes exposed to weather (and not installed in or below grade) shall be equipped with rain-tight or weatherproof-hinged doors.
 5. Exterior pull boxes shall have 16 gauge steel bodies and 14 gauge steel doors.
 6. Exterior pull boxes shall be equipped with external mounting feet.
 7. Exterior pull boxes shall be equipped with stainless steel door clamps on three sides and a removable stainless steel continuous hinge pin.
 8. Exterior pull boxes shall be equipped with a hasp and staple for padlocking
 9. Enclosures installed on vertical exterior walls shall conform to NEMA Type 3R.
 10. Enclosures installed on exterior horizontal surfaces such as rooftops or breezeways shall conform to NEMA Type 4 unless otherwise noted.
 11. Rain tight or weatherproof boxes shall use threaded watertight hubs for top or side entry and may use knockout for bottom entry only.
 12. Exterior pull boxes shall conform to these industry standards:
 - UL 508 Type 4
 - NEMA/EEMAC Type 3, Type 4, Type 12, Type 13
 - JIC standard EGP-1-1967
 - CSA Type 4
 - IEC 529, IP66
 13. Tamper resistant screws shall be used on all exterior, aboveground junction/pull boxes that are exposed to public/student areas.
 14. Exterior pull boxes shall be manufactured by Hoffman or LBUSD approved equal.

2.5 COMMUNICATION DUCT-BANKS AND CONDUITS

- A. Trenches
1. All underground trenches shall be minimum 24" wide by 30" deep.
 2. Trenches shall be back-filled at 95% compaction.

3. Contractor shall restore surface to same or better condition.
4. Contractor shall contact Dig Alert a minimum of 48 hours prior to excavation to verify the location of existing underground utilities.
5. Modifications to pathway design may be dictated by field conditions subject to approval by LBUSD.
6. Compaction testing notification must be provided to the District, 48 hours prior to testing so that a District inspector may be present.
7. Slurry fill trenches to within three inches (3") of finished grade whenever crossing paved areas. "Two Sack" slurry shall be used.
8. Pavement removal and patching shall conform to specifications and standards listed in the Public Works Standards (Green Book 2006).

B. Conduit

1. Underground conduit shall consist of Schedule 40 PVC - 2 inch inside diameter or type C telephone conduit - 2 inch inside diameter (if concrete encased)
2. Innerduct, where specified, corrugated or splined (inside and outside) flexible orange innerduct, 1 inch in diameter, riser rated, will be placed for fiber optic cable protection.
3. One (1) innerduct shall be placed in a 2-inch conduit. Innerducts are to be equipped with 1/8" pull ropes.
4. Conduit shall have a factory formed bell on one end for interconnecting segments.
5. Conduit located under heavy use highways or railroad rights-of-ways shall be encased in steel casing consistent with the AASHTO or AREA specifications. The thickness of the steel casing shall be engineered for each specific application. This may vary based on campus codes.
6. Spacers: High impact spacers shall be used in all multi-duct systems, for both solely owned or joint telecommunications/power construction. They shall conform with NEMA TC-2, TC-6, TC-8, and ASTM F 512 dimensions.
7. All fittings shall be designed specifically for use with the type of conduit placed.
8. All conduits shall be equipped with seal plugs in all ground boxes and expansion rubber seal plugs within all buildings.
9. A horizontal and vertical separation of 1 inch shall between the ducts be maintained by installing high impact spacers with horizontal and vertical locking intervals of ten feet.
10. All communications conduits shall be placed in a uniform manner between ground boxes and pull boxes. Conduit in position #1 at one ground box or pull box shall maintain its position within the duct run and terminate in the #1 position at the next box. The position of all conduits between ground boxes and pull boxes shall be maintained.
11. Long radius bends (over 30 feet) shall be used whenever possible to make changes in direction. If it is found to be necessary to place a 90-degree bend in

the conduit run, a factory-made sweep of no less than 60-inch radius shall be used.

12. No conduit run shall exceed a total of 180 degrees of bend between any two points (such as manholes or buildings) considering both vertical and horizontal sweeps.
13. Cold-formed trench bends shall have a radius of not less than 60 inches and shall pass mandrel integrity. Bend radius criterion is 2" or less 6 times the diameter of the conduit and any conduit larger than 2" is 10 times the diameter of the conduit.
14. The length and destination of all conduits shall be identified in each ground box, pull box and building. Embossed metal or heavy plastic tags strapped to each conduit shall be used.
15. After installation of communications conduits, the contractor shall prove all conduits by pulling a mandrel with a diameter ¼ inch smaller than the conduit and 6 inches long through each conduit end-to-end. An inspector designated by the contractor and LBUSD shall be notified 24 hours before this procedure. Each conduit shall be cleaned with a bristle brush to remove any debris.
16. Utility marking tape shall be buried 12 inches below the surface directly above the conduit.
17. Where communications and power conduits occupy the same trench, all conduit structures shall be built with the telecommunications conduits placed above the power conduits and separated by a minimum of 12" of compact earth or 3" of concrete encasement, unless otherwise called out on the construction drawings and approved by LBUSD. If this type of construction is required, it shall receive the prior approval of the contractor and LBUSD.
18. Contractor shall install new ¼" pull rope in all conduits placed.

C. Overhead Conduit

1. Where overhead conduit is required between or within buildings, Contractor shall utilize EMT conduit with an inside diameter of 2", unless otherwise specified.
2. All fittings shall be compression type connectors and couplers designed specifically for use with the type of conduit placed.
3. All fittings shall be watertight. Fitting types shall be pre-approved by the designated District representative. Unless pre-approved by the designated District representative, all conduits shall be installed by a qualified electrical contractor who has at least five years experience in similar installations within the Southern California area.
4. Contractor shall install conduit at roof locations utilizing the current District approved methodology and process. All conduit pathways and locations must be approved by LBUSD prior to installation.
5. All roof penetrations must be approved by LBUSD prior to installation.
6. Contractor shall install new ¼" pull rope in all conduits placed.

D. Communications Entrance Conduit

1. To prevent shear, all inter-building conduit (either underground or aerial) shall transition from PVC or metal to Sealtite flex conduit when attaching to a permanent structure. The contractor and LBUSD shall determine the placement of all entrance conduits. All applicable standards shall be adhered to, i.e., LBUSD, NEC, BICSI or G.O. 128.
2. Sealtight flex conduit lengths shall not exceed 24", unless approved by LBUSD.
3. Sealtight flex conduit may be used between adjacent bungalows within 24" of one another using District approved connectors and methods. Use of Seal Tite flex conduit between bungalow locations beyond the 24" distance shall require written authorization from LBUSD.
4. Contractor shall install new ¼" pull rope in all conduits placed.

E. Vertical Conduit

1. Where vertical conduit is required between pull boxes or within buildings, Contractor shall utilize EMT conduit with an inside diameter of 2", unless otherwise specified.

F. Duct-bank locating cable (electronically detectable warning tape)

1. Warning tape shall be a minimum of 3" wide, orange in color, and shall have a nondegradable imprint as follows:
 - "Caution fiber optic cable buried below"
 - The tape shall be electronically detectable.

G. Pull Rope

1. Pull rope shall be new ¼" polypropylene over polyester rope with a minimum 1700 lb. Tensile strength.
2. Pull rope shall be new material that is free of knots, kinks, and abrasions and shall be placed as a single continuous length in every new conduit.
3. Pull rope shall be secured at each end.

2.6 VELCRO TIE WRAPS

- A. Velcro cable ties shall be .5" in width.
- B. Velcro cable ties shall be black in color.
- C. Velcro cable ties installed in air-handling spaces shall be plenum-rated.
- D. Manufacturer: Panduit Or LBUSD Approved Equal

2.7 FIRESTOPPING MATERIAL

- A. Contractor shall provide all necessary fire stopping of openings through which cable is installed under this specification, in accordance with NFPA 70 and all local codes. This includes installation in conduits, raceways, or bare penetrations. Provide and install UL 1479 approved (Fire Barrier Caulk) firestop material.

2.8 DUCT SEALANT

- A. Contractor shall provide Polywater® Duct Sealant kit #FST-kit to seal each end of all underground communications duct bank conduits.
- B. Duct sealant shall be a two-part, "water-blown" urethane foam that cures to a strong, rigid closed-cell structure.
- C. Duct sealant shall be capable of wetting and adhesion to metal, concrete and plastic surfaces.
- D. Duct sealant shall be 100% water tight, holding 15-foot (5 meters) waterhead, and acts as a barrier to smoke and air.

PART 3 - EXECUTION

3.1 HORIZONTAL DISTRIBUTION CABLE INSTALLATION

- A. Cable shall be installed in accordance with manufacturer's recommendations and best industry practices.
- B. A pull cord (nylon; 1/8" minimum) shall be co-installed with all cable installed in any conduit.
- C. Cable raceways shall not be filled greater than the TIA/EIA-569-A maximum fill for the particular raceway type or 40%.
- D. Cables shall be installed in continuous lengths from origin to destination (no splices) except for transition points, or consolidation points.
- E. Where transition points or consolidation points are allowed, they shall be located in accessible locations and housed in an enclosure intended and suitable for the purpose.
- F. The cable's minimum bend radius and maximum pulling tension shall not be exceeded.
- G. If a J-hook or trapeze system is used to support cable bundles all horizontal cables shall be supported at a maximum of 48 to 60 inch (1.2 to 1.5 meter) intervals. At no point shall cable(s) rest on acoustic ceiling grids or panels.
- H. Horizontal distribution cables shall be bundled in groups of no more than 50 cables. Cable bundle quantities in excess of 50 cables may cause deformation of the bottom cables within the bundle and degrade cable performance.
- I. Cable shall be installed above fire-sprinkler systems and shall not be attached to the system or any ancillary equipment or hardware. The cable system and support hardware shall be installed so that it does not obscure any valves, fire alarm conduit, boxes, or other control devices.
- J. Cables shall not be attached to ceiling grid or lighting fixture wires. Where support for horizontal cable is required, the contractor shall install appropriate carriers to support the cabling.

- K. Any cable damaged or exceeding recommended installation parameters during installation shall be replaced by the contractor prior to final acceptance at no cost to the Owner.
- L. Cables shall be identified by a self-adhesive label in accordance with the System Documentation Section of this specification and ANSI/TIA/EIA-606.
- M. The cable label shall be applied to the cable behind the faceplate on a section of cable that can be accessed by removing the cover plate.
- N. Unshielded twisted pair cable shall be installed so that there are no bends smaller than four times the cable outside diameter at any point in the run and at the termination field.
- O. Pulling tension on 4-pair UTP cables shall not exceed 25-lbf for a four-pair UTP cable.

3.2 OPEN CABLE INSTALLATION

- A. Use only where specifically indicated on plans or determined during site surveys.
- B. When not run in surface mounted raceway or conduit, utilize non-continuous cable support above suspended ceilings and in all ceiling spaces.
- C. Install cabling above suspended ceilings 6 to 12 inches above ceiling T-bar using non-continuous cable support spaced on 24 to 48 inch centers and securely attached to structural ceiling.
- D. Do not exceed cable pull tensions recommended by the manufacturer.
 - 1. Avoid routing copper cable in areas where there may be high levels of electromagnetic interference (EMI). EMI is caused by AC power lines, broadcast signals, X-ray equipment, motors, generators, and fluorescent lights. UTP cables shall be routed at least 5 inches away from fluorescent lighting fixtures.
 - 2. Cables shall be placed in the non-continuous cable support located every 2 to 4 feet, as long as they are separately bundled and tie-wrapped using Velcro ties.
 - 3. Cabling shall be organized and identified so as to facilitate locating and handling individual sheaths for maintenance functions.
 - 4. Each bundle shall be neatly tied without over cinching or stressing cable.
 - 5. Bundles shall be clearly marked identifying the IDF and room to which routed, the station numbers served by the bundle, and any other information that may assist in administration.
 - 6. Great care shall be taken to protect all cabling from physical damage.
 - 7. A 20' service loop shall be installed above ceiling on each cable installation where possible.

3.3 FIRESTOP

- A. A firestop system is comprised of the item or items penetrating the fire rated structure, the opening in the structure and the materials and assembly of the

materials used to seal the penetrated structure. Firestop systems comprise an effective block for fire, smoke, heat, vapor and pressurized water stream.

- B. All penetrations through fire-rated building structures (walls and floors) shall be sealed with an appropriate firestop system. This requirement applies to through penetrations (complete penetration) and membrane penetrations (through one side of a hollow fire rated structure). Any penetrating item (i.e., riser slots and sleeves, cables, conduit, cable tray, and raceways, etc.) shall be properly fire stopped.
- C. All firestop systems shall be installed in accordance with the manufacturer's recommendations and shall be completely installed and available for inspection by the local inspection authorities prior to cable system acceptance.

3.4 DUCT SEALANT

- A. Contractor shall install duct sealant in each end of underground duct bank conduits.
- B. All occupied and vacant communications duct bank conduits shall be sealed.
- C. Each underground duct bank conduit entering underground pull boxes shall have duct sealant installed.
- D. Each underground duct bank conduit stubbing up through building foundation shall have duct sealant installed.
- E. Each underground duct bank conduit through building wall shall have duct sealant installed.
- F. Each underground duct bank conduit end shall be sealed to be 100% water tight.

END OF SECTION



SECTION 27 10 70

COMMUNICATIONS TESTING, IDENTIFICATION AND ADMINISTRATION

PART 1 – GENERAL

1.1 RELATED DOCUMENTS

- A. SECTION 27 05 05 - COMMON WORK RESULTS FOR COMMUNICATIONS, this document describes the LBUSD products, execution, qualifications, manufacturer warranties, and coordination requirements relating to furnishing and installing a complete, turn-key Communications Cabling System.
- B. SECTION 27 05 26 - GROUNDING AND BONDING FOR COMMUNICATIONS SYSTEMS, this document describes the products and execution requirements relating to furnishing and installing Grounding/Earthing and Bonding for Communications Systems.
- C. SECTION 27 05 28 – PATHWAYS FOR COMMUNICATIONS SYSTEMS, this document describes the products and execution requirements relating to furnishing and installing Telecommunications Cabling pathways. Communication cabling support is covered under this document.
- D. SECTION 27 11 16 – COMMUNICATIONS CABINETS AND ENCLOSURES, this document describes the products and execution requirements relating to furnishing and installing Communication Equipment Room Fittings of cabinets, cable management, and telecommunications backboards are covered under this document.
- E. SECTION 27 11 19 – COMMUNICATIONS PATCH PANELS, this document describes the products and execution requirements relating to furnishing and installing Structured Communications Cable System (SCCS) Category 5e and Category 6 patch panels are covered under this document.
- F. SECTION 27 13 23 – COMMUNICATIONS OPTICAL FIBER BACKBONE CABLING, this document describes the products and execution requirements relating to furnishing and installing Telecommunications Cabling Optical fiber backbone cabling and terminations are covered in this document.
- G. SECTION 27 15 00.19 – DATA COMMUNICATIONS HORIZONTAL CABLING, this document describes the products and execution requirements relating to furnishing and installing Horizontal Cabling. Data Communications Horizontal Cabling is covered under this document.
- H. SECTION 27 15 43 - COMMUNICATIONS FACEPLATES AND CONNECTORS, this document describes the products and execution requirements relating to furnishing and installing faceplates, connectors, Category 5e and Category 6 patch cords. Communications faceplates and connectors are covered under this document.

1.2 SCOPE OF WORK

- A. This document describes the products and execution requirements relating to testing, labeling, warranties and As-Builts related to Communications Cabling Systems.

1.3 IDENTIFICATION AND LABELING

- A. The contractor shall label the cabling system as indicated on the drawings and in accordance with TIA 606 Standards.
- B. All label printing will be machine generated. Self-laminating labels will be used on cable jackets, appropriately sized to the OD of the cable, and placed within view at the termination point on each end. Outlet, patch panel and wiring block labels shall be installed on, or in, the space provided by the termination device or housing.
- C. Identification of cabling, pathways and hardware shall conform to TIA 606-A. The labeling scheme for the structured cabling system shall be submitted to LBUSD Representative for approval and inclusion in all matrices for building operations prior to trim/finish. Faceplate, insert and dust cover shall be same color.
- D. Each information outlet faceplate and each telephone and data wire shall be labeled following University standards. The labels shall be made of waterproof material and be mechanically printed with permanent black ink. The labels must be legible with the same identification numbering corresponding to both ends. Each information outlet faceplate has removable covers that hide the mounting screws. They are located above and below each pair of module knockouts. The approved adhesive backed label should be placed on the outside of the top removable cover. The generic Systimax cover that comes with the faceplate should be used below the lower knockouts. At the MDF the telephone wiring shall be labeled on the protector blocks with black indelible ink in numerical order. Data wiring at the MDF/IDF closet should be labeled with mechanically printed labels both on the wire and on the patch panels utilizing specified label strips. Labeling products must be approved by LBUSD Representative prior to use.
- E. The standard LBUSD Telecommunications and Networking outlet label format consists of:
 - 1. Floor#-IDF#-Cable I.D.
 - 2. Floor # - Is the floor that the terminal closet is located on.
 - 3. IDF # - Designates which closet on the floor that the outlet is served from.
 - 4. Cable I.D. # - The individual outlet number used to identify the wire on both ends.
- F. Sample Faceplate Labeling Format

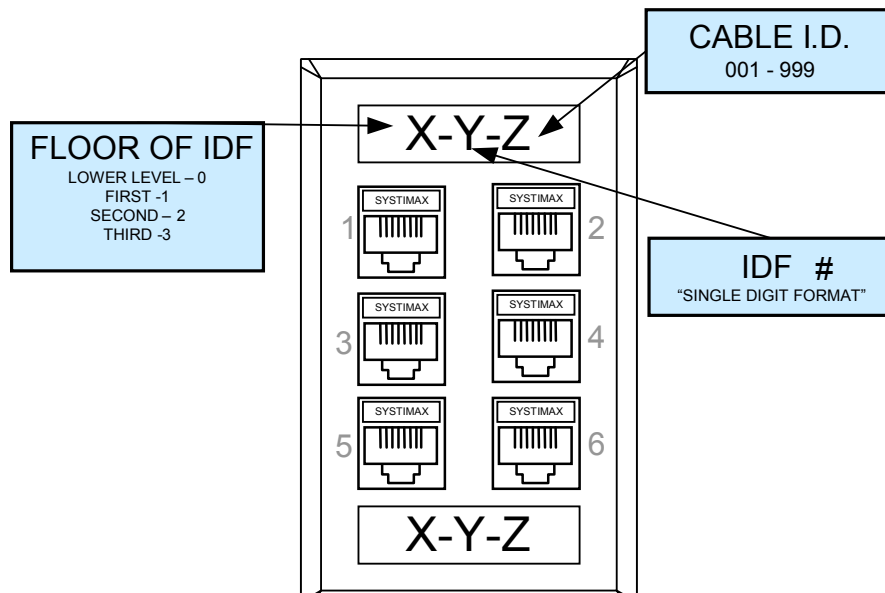

1. Faceplate Configurations – Figure 1

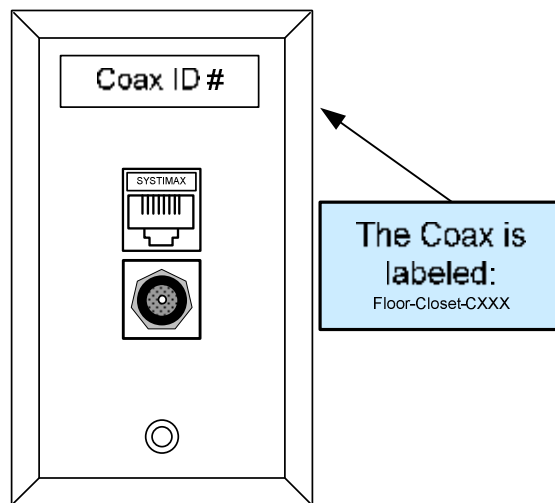

2. Faceplate Configurations – Figure 2

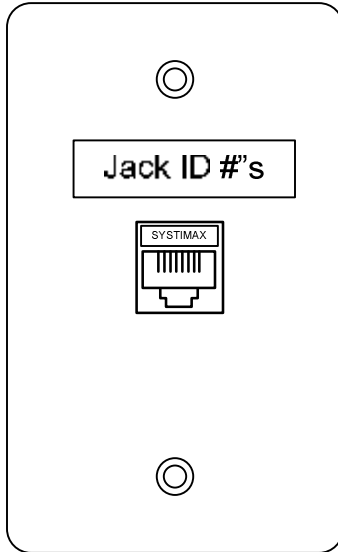

3. Faceplate Configurations – Figure 3

G. Backbone Copper Label Scheme for Inter-building:

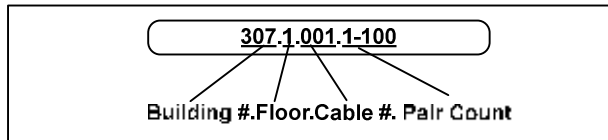

1. Example: From MDF to IDF, Building #. Floor. Cable #. Pair Count.

H. Backbone Copper Label Scheme for Intra-building Cables:

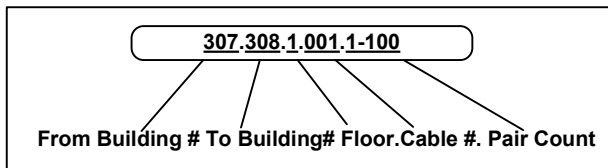

1. Example: From Building# .To Building#. Floor. Cable#. Pair Count

I. Fiber Backbone Labeling Scheme for Inter-building Cables:

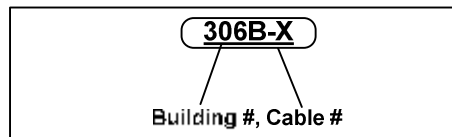

1. Example: From MDF to IDF, Building # - Cable #.
 306B-1, 306B-2, 306B-3, ETC.....
 Cable: xxx-306B-1 will be the feed cable to the Building from Building xxx.

J. Fiber Backbone Labeling Scheme for Intra-building Cables:

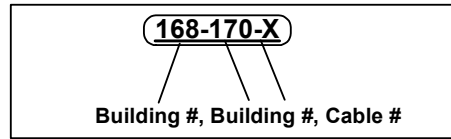

1. Example: To - From, Building # - Building # - Cable #.
In Building #168, Cable# shall read, **170-168-1**.



2. Example: In Building #170, Cable shall read, **168-170-1**.

K. Fiber Patch Panel Labeling:

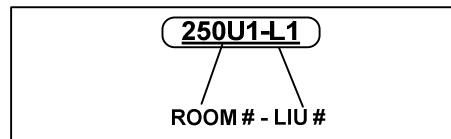

1. Example:
 - ROOM # 250U1, Patch Panel #1 = 250U1-L1
 - ROOM # 250U1, Patch Panel #2 = 250U1-L2
 - ROOM # 250U1, Patch Panel #3 = 250U1-L3

1.4 TESTING AND LBUSD ACCEPTANCE

A. GENERAL

1. All cables and termination hardware shall be 100 percent tested for defects in installation and to verify cabling system performance under installed conditions according to the requirements of ANSI/TIA-568-C.1 and TIA-568-C.2 and associated addendums. All pairs of each installed cable shall be verified prior to system acceptance. Any defect in the cabling system installation including but not limited to cable, connectors, feed through couplers, patch panels, and connector blocks shall be repaired or replaced in order to ensure 100 percent useable conductors in all cables installed.
2. All cables shall be tested in accordance with this document, the ANSI/TIA standards, manufacturer specifications and best industry practice. If any of these are in conflict, the Contractor shall bring any discrepancies to the attention of the project team for clarification and resolution.

B. TEST EQUIPMENT

1. UTP cable tests shall be conducted with Fluke testers with test results submitted with the latest version of Linkware software.
2. All balanced twisted-pair field testers shall be factory calibrated each calendar year by the field test equipment manufacturer as stipulated by the manuals provided with the field testing unit. The calibration certificate shall be provided for review prior to the start of testing.
3. Autotest settings provided in the field tester for testing the installed cabling shall be set to the default parameters.
4. Test settings selected from options provided in the field testers shall be compatible with the installed cabling to be tested.

C. COPPER PERMANENT LINK TESTING

1. All twisted-pair copper cable links shall be tested for continuity, pair reversals, shorts, opens and performance as indicated below. Additional testing is required to verify Category performance.
2. Continuity - Each pair of each installed cable shall be tested using a test unit that shows opens, shorts, polarity and pair-reversals, crossed pairs and split pairs. Shielded/screened cables shall be tested with a device that verifies shield continuity in addition to the above stated tests. The test shall be recorded as pass/fail as indicated by the test unit in accordance with the manufacturers' recommended procedures, and referenced to the appropriate cable identification number and circuit or pair number. Any faults in the wiring shall be corrected and the cable re-tested prior to final acceptance.
3. Length - Each installed cable link shall be tested for installed length using a TDR type device. The cables shall be tested from patch panel to patch panel, block to block, patch panel to outlet or block to outlet as appropriate. The cable length shall conform to the maximum distances set forth in the ANSI/TIA-568-C Standard. Cable lengths shall be recorded, referencing the cable identification number and circuit or pair number. For multi-pair cables, the shortest pair length shall be recorded as the length for the cable.
4. Category 6 balanced twisted-pair horizontal, whose length does not exceed 90 m (295 ft) for the basic link, and 100 m (328 ft) for the channel shall be 100 percent tested according to ANSI/TIA-568-B.1. Test parameters include wire map, length, NEXT loss (pair-to-pair), NEXT loss (power sum), ELFEXT loss (pair-to-pair), ELFEXT loss (power sum), return loss, insertion loss, propagation delay, and delay skew.
5. Perform 250 MHz near end cross talk (NEXT) and attenuation tests for Category 6 systems installations.
6. Category 6 Links. Perform UTP link tests in accordance with TIA/EIA-568.B.1, B.2 and manufactures guidelines.
7. Category 6 tests shall include wire map, length, attenuation, NEXT, PSNEXT, ELFEXT, PSELFEXT, RL and propagation delay.
6. All installed category 6 channels shall perform +3dB of headroom or better than the minimum requirements.
7. Category 5e balanced twisted-pair horizontal, whose length does not exceed 90 m (295 ft) for the basic link, and 100 m (328 ft) for the channel shall be 100

percent tested according to ANSI/TIA-568-B.1. Test parameters include wire map, length, NEXT loss (pair-to-pair), NEXT loss (power sum), ELFEXT loss (pair-to-pair), ELFEXT loss (power sum), return loss, insertion loss, propagation delay, and delay skew.

8. Perform 100 MHz near end cross talk (NEXT) and attenuation tests for Category 5e systems installations.
9. Category 5e Links. Perform UTP link tests in accordance with TIA/EIA-568 C.1, C.2 and manufactures guidelines.
10. Category 5e Tests shall include wire map, length, attenuation, NEXT, PSNEXT, ELFEXT, PSELFEXT, RL and propagation delay.

D. FIBER TESTING

1. All backbone fiber testing shall be performed on all fibers in the completed end-to-end system. There shall be no splices unless clearly defined. Testing shall consist of an end-to-end power meter test performed per TIA-455-53A. The system loss measurements shall be provided at 850 and 1300 nanometers for multimode fibers and 1310 and 1550 nanometers for singlemode fibers. These tests also include continuity checking of each fiber strand.
2. All backbone multimode fiber cabling shall be tested at both 850 nm and 1300 nm (or 1310 and 1550 nm for singlemode) bi-directionally utilizing an OTDR test unit.
3. Test set-up and performance shall be conducted in accordance with ANSI/TIA-526-14 Standard, Method B.
4. Where links are combined to complete a circuit between devices, the Contractor shall test each link from end to end to ensure the performance of the system. Only basic link test is required. The contractor can optionally install patch cords to complete the circuit and then test the entire channel. The test method shall be the same used for the test described above. The values for calculating loss shall be those defined in the ANSI/TIA 568-C.3 Standard.
5. Attenuation testing shall be performed with a stable launch condition using two-meter jumpers to attach the test equipment to the cable plant. The light source shall be left in place after calibration and the power meter moved to the far end to take measurements.

1.5 SYSTEM DOCUMENTATION

- A. Upon completion of the installation, the contractor shall provide 3 full documentation sets to the LBUSD for approval. Documentation shall include the items detailed in the sub-sections below.
- B. Documentation shall be submitted within 10 working days of the completion of each testing phase (e.g. subsystem, cable type, area, floor, etc.). This is inclusive of all test result and draft as-built drawings. Draft drawings may include annotations done by hand. Machine generated (final) copies of all drawings shall be submitted within 30 working days of the completion of each testing phase. At the request of the LBUSD, the contractor shall provide copies of the original test results.
- C. The LBUSD may request that a 10 percent random field re-test be conducted on the cable system, at no additional cost, to verify documented findings. Tests shall be a

repeat of those defined above. If findings contradict the documentation submitted by the contractor, additional testing can be requested to the extent determined necessary by the LBUSD, including a 100 percent re-test. This re-test shall be at no additional cost to the LBUSD.

- D. Contractor shall complete LBUSD-provided matrix to include data cabling patching information within the Telecommunications Rooms and MDF. Information to be provided shall include, and not be limited to; Room number, data outlet ID, Patch panel, patch panel port, switch, and switch port. Documentation shall be submitted within 30 days prior to the completion of the project.

1.6 TEST RESULTS

- A. Test documentation shall be provided on compact disk within three weeks after the completion of the project. The disk shall be clearly marked on the outside front cover with the words "Project Test Documentation", the project name, and the date of completion (month and year). This compact disk shall include any and all software required to view test results. Test results file formats shall be in the original format extracted from the test unit. A file exported to an editable file format is not an acceptable alternate. The results shall include a record of test frequencies, cable type, conductor pair and cable (or outlet) I.D., measurement direction, reference setup, PASS/FAIL result, and crew member name(s). The test equipment name, manufacturer, model number, serial number, software version and last calibration date will also be provided at the end of the document. Unless the manufacturer specifies a more frequent calibration cycle, an annual calibration cycle is anticipated on all test equipment used for this installation. The test document shall detail the test method used and the specific settings of the equipment during the test as well as the software version being used in the field test equipment.
- B. The field test equipment shall meet the requirements of ANSI/TIA-568-B.1 and TIA-568-B.2 including applicable TSB's and amendments. A Fluke tester shall be used to verify Category 6 cabling systems.
- C. Printouts generated for each individual wire (or fiber strand) by the test instrument shall be submitted as part of the documentation package. Alternately, the contractor must furnish this information in electronic form (compact disk). This compact disk shall contain the electronic equivalent of the test results as defined by the bid specification and be of the native format complete with software required to view the test data.
- D. When repairs and re-tests are performed, the problem found and corrective action taken shall be noted, and both the failed and passed test data shall be documented.

1.7 AS-BUILT DRAWINGS

- A. The drawings are to include cable routes and outlet locations. Outlet locations shall be identified by location and complete jack number. Numbering, icons, and drawing conventions used shall be consistent throughout all documentation provided. The LBUSD will provide floor plans in paper and electronic (DWG, AutoCAD 2007 or later) formats on which as-built construction information can be added. These documents will be modified accordingly by the contractor to denote as-built information as defined above and returned to the LBUSD.

1.8 WARRANTY

- A. An Extended Product Warranty shall cover all labor and materials. Warranty shall be provided from the Product Manufacturer, which warrants functionality of all

components used in the system for no less than 20 years from the date of registration. The Extended Product Warranty shall warrant the installed horizontal and backbone copper UTP, and the backbone fiber optic portions of the cabling system. The Warranty shall cover the failure of the wiring system to support the applications that are designed for the link/channel specifications of TIA-568-C.1 and TIA-568-C.2. These applications included, but are not limited to, 10BASE-T, 100BASE-T, 1000BASE-T, and 155 Mbps ATM. The Contractor shall be certified to install the product to qualify for the Manufacturer Extended Product Warranty. As part of the proposal, contractor shall submit documentation explaining how the proposed manufacturer will support future applications over Category 5e or Category 6.

1.9 FINAL LBUSD ACCEPTANCE AND SYSTEM CERTIFICATION

- A. Successful completion of the installation, in-progress and final inspections, receipt of the test and as-built documentation, and successful performance of the cabling system for a two-week period will constitute acceptance of the system. Upon successful completion of the installation and subsequent inspection, the LBUSD shall be provided with a numbered certificate from the Manufacturer registering the installation. LBUSD will appoint an authorized agent that will sign a formal acceptance document upon completion of all of the above.

PART 2 - PRODUCTS (Not Used)

PART 3 - EXECUTION (Not Used)

END OF SECTION



SECTION 27 11 16

COMMUNICATIONS CABINETS AND ENCLOSURES

PART 1 - GENERAL

1.1 RELATED DOCUMENTS

- A. SECTION 27 05 05 - COMMON WORK RESULTS FOR COMMUNICATIONS, this document describes the LBUSD products, execution, qualifications, manufacturer warranties, and coordination requirements relating to furnishing and installing a complete, turn-key Communications Cabling System.
- B. SECTION 27 05 26 - GROUNDING AND BONDING FOR COMMUNICATIONS SYSTEMS, this document describes the products and execution requirements relating to furnishing and installing Grounding/Earthing and Bonding for Communications Systems.
- C. SECTION 27 05 28 – PATHWAYS FOR COMMUNICATIONS SYSTEMS, this document describes the products and execution requirements relating to furnishing and installing Telecommunications Cabling pathways. Communication cabling support is covered under this document.
- D. SECTION 27 05 28.36 - CABLE TRAYS FOR COMMUNICATIONS SYSTEMS, This document describes the products and execution requirements relating to furnishing all necessary labor, supervision, materials, equipment, tests and services to install complete cable tray systems to support low-voltage signal and communications cabling as shown on the drawings.
- E. SECTION 27 10 70 - COMMUNICATIONS TESTING, IDENTIFICATION AND ADMINISTRATION, this document describes the products and execution requirements relating to testing, labeling, warranties and As-Built related to Communications Cabling Systems.
- F. SECTION 27 11 19 – COMMUNICATIONS PATCH PANELS, this document describes the products and execution requirements relating to furnishing and installing Structured Communications Cable System (SCCS) Category 6 patch panels are covered under this document.
- G. SECTION 27 13 23 – COMMUNICATIONS OPTICAL FIBER BACKBONE CABLING, this document describes the products and execution requirements relating to furnishing and installing Telecommunications Cabling Optical fiber backbone cabling and terminations are covered in this document.
- H. SECTION 27 15 00.19 – DATA COMMUNICATIONS HORIZONTAL CABLING, this document describes the products and execution requirements relating to furnishing and installing Horizontal Cabling. Data Communications Horizontal Cabling is covered under this document.

- I. SECTION 27 15 43 - COMMUNICATIONS FACEPLATES AND CONNECTORS, this document describes the products and execution requirements relating to furnishing and installing faceplates, connectors and Category 6 patch cords. Communications faceplates and connectors are covered under this document.

1.2 WORK INCLUDED

- A. Provide all labor, materials, tools and equipment required for the complete installation of work called for in the Construction Documents

1.3 SCOPE OF WORK

- A. This document describes the products and execution requirements relating to furnishing and installing Communication Equipment Room Fittings of cabinets, cable management, and telecommunications backboards are covered under this document.
- B. This section includes minimum requirements for the following:
 - 1. Equipment Cabinets
 - 2. MDF Cabinet Mounted LCD Monitor/Keyboard Drawer
 - 3. Cable Management
 - 4. Wall Mounted Equipment Enclosures
 - 5. Rack mounted power distribution strips
 - 6. Cable Runway
 - 7. Telecommunications Backboards

1.4 APPROVED PRODUCTS

- A. Approved equipment cabinet manufacturer: Hoffman
- B. Approved horizontal cable manager manufacturer: Hoffman
- C. Approved wall mounted equipment enclosure manufacturer: Hoffman
- D. Approved cable runway manufacturer: Chatsworth Products Inc.
- E. Approved power distribution strip manufacturer: Chatsworth Products Inc. or LBUSD approved equal.
- F. Approved MDF Cabinet Mounted LCD Monitor/Keyboard Drawer: APC or LBUSD approved equal.

1.5 DEFINITIONS

1.5.1 Main Distribution Frame (MDF)

- A. A physical concentration or central location for terminating backbone cables to interconnect with local exchange carrier (LEC) equipment at the activity minimum point of presence. The MDF generally includes vendor specific components to support voice and data circuits, building surge protector assemblies, main cross connect blocks, equipment support frames, and plywood backboard (if MDF is wall mounted). Depending upon local site conditions, the MDF and IDF may be identical.

1.5.2 Intermediate Distribution Frame (IDF)

- A. An intermediate termination point for horizontal wiring and cross connections normally within another structure separate from the MDF.

PART 2 - PRODUCTS

2.1 COMMUNICATIONS EQUIPMENT ROOM FITTINGS

- A. Provide main distribution frames (MDF) and intermediate distribution frames (IDF's), per each project site walk for terminating and cross connecting permanent cabling.

2.2 WALL MOUNTED EQUIPMENT ENCLOSURES

- A. Fully enclosed lockable, modular type steel construction and treated to resist corrosion.
- B. Front door shall include tinted, safety glass window.
- C. IDF cabinets shall be wall mount/swing out type and provide 19" rack mounting with a minimum static load rating of 300 lbs for 36" high unit and 500 lbs for 72" high unit.
- D. Rack shall be designed to allow for left or right-hand swing. Dimensions shall be a minimum of 36.02"H X 23.62" W X 30.01" D.
- E. In selected cases, a 72.05" high cabinet will be used. Larger cabinet size will be determined on a project-by-project basis.
- F. Cabinet shall be mounted on plywood backboard in location to be determined.
- G. Contractor shall be responsible for determining correct cabinet mounting and anchoring methods that will safely support the combined weight of the cabinet and data network components that will occupy the cabinet.
- H. Cabinet mounting and anchoring methods shall comply with LBUSD and State building and safety codes.
- I. When wall mounted cabinets are installed in classrooms, the contractor shall responsible for providing and installing Acoustical Absorber foam material on inside, back of cabinet. Acoustical Absorber shall be flexible, ½" thick, polyurethane, adhesive backed foam.
- J. Drywall screws shall not be used for mounting of cabinets.
- K. Contractor shall be responsible for ensuring that cabinet mounting and anchoring methods comply with Part 3- Execution 3.1.3.
- L. Manufacturer: Hoffman AccessPlus II Double-Hinge Wall-Mount Cabinet.

2.3 EQUIPMENT CABINETS

- A. The unit shall be designed to provide a secure, managed environment for computer and networking equipment with a static load rating of 1500 lbs.
- B. The unit shall conform to EIA/ECA-310-E standard with square mounting holes to accommodate industry standard 19" rack mount equipment, fasteners and cage nuts.
- C. The unit shall be designed with four (4) vertical posts to allow rack mount equipment installation utilizing four (4) vertical mounting rails.

- D. The unit shall provide 42U of equipment vertical mounting space (1U=1.75" or 44.45mm).
- E. The vertical mounting rails shall be adjustable to allow different mounting depths.
- F. The unit shall include minimum 60 sets of caged nuts, mounting screws, cup washers, and caged nut installation tool for the mounting of equipment inside the unit.
- G. Both front and rear doors shall consist of quick release hinges allowing for quick and easy detachment without the use of tools.
- H. The front and rear doors shall open a minimum of 180 degrees to allow easy access to the interior.
- I. The front and rear doors shall be reversible so that it opens from either side.
- J. The base unit shall include removable side panels that are removed without tools using easy finger latches for fast access to cabling and equipment.
- K. All weight bearing components shall be constructed from steel no less than 0.9mm (20 gauge).
- L. All metal parts shall be painted using a powder coat paint process.
- M. Plastic materials shall comply with Underwriters Laboratory Specification 94 with V-1 rating (UL94 V-1) or better.
- N. Provisions shall be provided for all enclosure panels and rack-mounted equipment to be earthed or grounded directly to the frame.
- O. Unit shall include a grounding kit containing terminated green/yellow jumper wires and associated hardware.
- P. Units shall be equipped with vertical wire management rings.
- Q. Each cabinet installed shall have one (19"Wx3"Dx3"H) horizontal wire manager installed at top/rear portion of the cabinet.
- R. Units shall be equipped with vented front window door and perforated rear doors with key locks, perforated top and solid side panels.
- S. Baying brackets shall be provided where mounting multiple cabinets are to be mounted together.
- T. Cabinet Frame with front and rear mesh doors.
- U. "Side Panels" required.
- V. Unit shall have base dimension of 82.30 inches in height by 23.94 inches in width by 43.28 inches in depth.
- W. Units shall be black in color.
- X. Cabinets shall be seismic/earthquake braced and anchored to floor.
- Y. Each campus MDF shall include two, free standing equipment cabinets.
- Z. Manufacturer: Hoffman Proline Server Cabinets.

2.4 MDF EQUIPMENT CABINET POWER DISTRIBUTION STRIP

- A. Each equipment cabinet shall come equipped with two 5-foot power distribution strips with (10) 20 amp (NEMA 5-20R) receptacles mounted 6 inches on center.
- B. Manufacturer: Chatsworth Products Inc. or LBUSD approved equal.

2.5 MDF CABINET MOUNTED LCD MONITOR/KEYBOARD DRAWER

- A. Contractor shall provide and install one rack-mounted LCD monitor/keyboard drawer at MDF cabinet location designated by LBUSD.
- B. Unit shall include full Size Keyboard, Energy Saver, adjustable mounting depth, Integrated Trackball, Low Cooling Requirements, Low Power Consumption, On-Screen Display (OSD) adjustments, PC mouse/keyboard/video support, PS/2 terminations, and Standard VGA termination.
- C. Characteristics: LCD monitor/keyboard shall be:
 - 1. Rack mounted LCD monitor/keyboard drawers shall only 1U (1.75") of rack space.
 - 2. 1024 X 768 Resolution, 15" TFT active matrix screen.
 - 3. Unit shall include cable management arm, mounting hardware, Qty 1 - IEC to IEC 320 Power Cord, Qty 1 - IEC to NEMA 5-15P Power Cord.
 - 4. Nominal input voltage shall be 100, 120, 208, 230, 240 V.
 - 5. Input frequency (Hz) shall be 50/60 Hz.
 - 6. Input Connection Type shall be NEMA 5-15P, IEC-320 C14.
 - 7. Unit shall be equipped with power cord 6 feet in length (1.83 meters).
- D. Manufacture: APC or LBUSD approved equal

2.6 MDF CABINET SLIDING EQUIPMENT SHELVES

- A. Contractor shall provide and install two rail-mounted sliding equipment shelves within every cabinet installed.
- B. Shall occupy 1U of rack space.
- C. Shall be equipped to slide out.
- D. Net Width 16.20 inches.
- E. Net Depth 37.40 inches.
- F. Color shall be black.
- G. Manufacturer: Hoffman Net Series or LBUSD approved equal

2.7 CABLE RUNWAY

- A. Cable runway shall be installed in new campus MDF/IDF Rooms. Size: minimum 12 inch wide, plus side channel, as needed.

- B. Classified by Underwriters Laboratories (UL) as suitable for equipment grounding.
- C. Cable runway shall be used for voice and, or data and video communications cabling only. No electrical wiring shall be placed in cable runway with voice and data cabling.
- D. Wall angle supports shall be steel angles. Ends to be smooth without hooks or projections. Brackets shall be able to support an end load of 600 lb. with a safety factor of 1.65.
- E. Elbows, Tee's, 90-degree bends and crosses: All horizontal and vertical 90-degree elbows, tees, 90-degree bends and crosses shall be made with right angle couplings, which clamp to the runway without the need for drilling or cutting.
- F. At all horizontal 90-degree bends, tees, and crosses, provide adjustable junction splice kits for large radius cable bends.
- G. Seismically supported by end wall supports, angular wall supports and communications equipment racks.
- H. Black baked enamel finish.
- I. Manufacturer: Chatsworth Products #10250-7XX or LBUSD approved equal.

2.8 CABLE MANAGEMENT

- A. All equipment cabinets shall be equipped with horizontal cable management organizers for each fiber optic and UTP patch panel.
- B. Horizontal cables managers shall be single-sided with black finish and be 2 rack units in height. Horizontal cable managers shall have cable pass-thru, removable hinged cover and evenly spaced "fingers" designed to maintain and allow the entry and exit of jumper, patch, or cross-connect cables and/or wires in place.
- C. Horizontal cable managers shall be designed to extend past the frame to allow placement of equipment in any position within the rack. When mounted between equipment rack frame rails, they shall be securely mounted to equipment rack frame rails.
- D. Horizontal Cable Managers Manufacturer: Hoffman DCHS2.

2.9 TELECOMMUNICATIONS BACKBOARD

- A. Provide fire rated plywood 3/4 inch thick, minimum 36"H X 24" W for mounting of wall mounted cabinets.
- B. Backboards shall be painted with a light color, nonconductive fire-resistant overcoat.
- C. Cabinet shall be mounted on plywood backboard in location to be determined.
- D. Contractor shall be responsible for determining correct backboard sizing, mounting and anchoring methods that will safely support the combined weight of the backboard, cabinet and data network components that will occupy the backboard.
- E. Backboard mounting and anchoring methods shall comply with LBUSD and State building and safety codes.

- F. Contractor shall be responsible for ensuring that cabinet mounting and anchoring methods comply with Part 3- Execution 3.1.3.
- G. Drywall screws shall not be used to mount plywood backboards.

PART 3 - EXECUTION

3.1 INSTALLATION

- A. Telecommunications cabling and pathway systems, including the horizontal and backbone cable, pathway systems, telecommunications outlet/connector assemblies, and associated hardware shall be installed in accordance with TIA/EIA-568-B.1, B.2, B.3, TIA/EIA-569-A, NFPA 70, and UL standards as applicable.
- B. Cabling shall be connected in a star topology network.
- C. Contractor shall provide all necessary tools and materials not specified, (tie wraps, “d” rings, screws, consumables, hardware, etc.) and equipment, (ladders, hydraulic lifts, storage containers, etc.) necessary to provide a complete and operating system.
- D. Installation methodologies shall adhere to manufacturer installation procedures so as to not violate certifications (i.e. UL).
- E. All work shall be performed in a good workmanship-like manner leaving each location in the same or better condition as at the start of each project.
- F. The designated District representative shall be provided progress reports.
- G. Periodic on-site inspections will be done during the course of installation.
- H. The District reserves the right of “local jurisdiction” for final approval.

3.2 MDF/IDF CABLE INSTALLATION AND TERMINATION

- A. Cables shall be dressed and terminated in accordance with the recommendations made in the TIA/EIA-568-B standard, manufacturer’s recommendations and best industry practices.
- B. Pair untwist at the termination shall not exceed 3.18 mm (0.125 inch).
- C. Bend radius of the cable in the termination area shall not exceed 4 times the outside diameter of the cable.
- D. Cables shall be neatly bundled and dressed to their respective panels or blocks. Each panel or block shall be fed by an individual bundle separated and dressed back to the point of cable entrance into the rack or frame.
- E. The cable jacket shall be maintained as close as possible to the termination point.
- F. Each cable shall be clearly labeled on the cable jacket behind the patch panel at a location that can be viewed without removing the bundle support ties. Cables labeled within the bundle, where the label is obscured from view shall not be acceptable.

3.3 BACKBOARD AND EQUIPMENT SUPPORT CABINET

- A. Contractor shall coordinate with LBUSD, the MDF/IDF backboard and equipment support cabinet mounting locations and mounting methods. New MDFs shall be

provided with two, free standing equipment cabinets. Existing campuses may require wall mounted equipment cabinets.

- B. Free standing MDF equipment cabinets shall be seismically anchored to the floor and to the overhead cable runway.
- C. Wall mounted equipment support cabinet shall be mounted on plywood backboard in location to be determined. Quantities and locations to be coordinated with LBUSD.
- D. Contractor shall coordinate with LBUSD, the required equipment support cabinet dimensions.
- E. Contractor shall provide and install fasteners and anchors that are designed and rated for determined mounting surface and building construction type.
- F. Contractor shall provide and install fasteners and anchors that are designed and rated for the combined weight of the equipment support cabinet and its contents.
- G. Contractor shall be responsible for determining correct cabinet mounting and anchoring methods that will safely support the combined weight of the cabinet and data network components that will occupy the cabinet.
- H. Contractor shall install MDF/IDF plywood backboard and equipment support cabinet in such a manner, that a minimum of four (4) backboard fasteners and/or anchors are attached directly into wall framing studs, or if applicable, masonry wall.
- I. Contractor shall install MDF/IDF equipment support cabinet in such a manner, that a minimum of four (4) cabinet mounting point fasteners attaches the cabinet directly to the plywood backboard.
- J. Contractor shall not use dry wall screws as fasteners for backboard and cabinet.
- K. Cabinet mounting and anchoring methods shall comply with LBUSD and State building and safety codes.
- L. Contractor shall be responsible for costs of all repairs if equipment support cabinet installation methods are determined to be inadequate by LBUSD or if contractor provided and installed fasteners and/or anchors fail, resulting with the equipment support cabinet pulling away from wall or completely falling off of wall.

END OF SECTION



SECTION 27 11 19

COMMUNICATIONS PATCH PANELS

PART 1 - GENERAL

1.1 RELATED DOCUMENTS

- A. SECTION 27 05 05 - COMMON WORK RESULTS FOR COMMUNICATIONS, this document describes the LBUSD products, execution, qualifications, manufacturer warranties, and coordination requirements relating to furnishing and installing a complete, turn-key Communications Cabling System.
- B. SECTION 27 05 26 - GROUNDING AND BONDING FOR COMMUNICATIONS SYSTEMS, this document describes the products and execution requirements relating to furnishing and installing Grounding/Earthing and Bonding for Communications Systems.
- C. SECTION 27 05 28 – PATHWAYS FOR COMMUNICATIONS SYSTEMS, this document describes the products and execution requirements relating to furnishing and installing Telecommunications Cabling pathways. Communication cabling support is covered under this document.
- D. SECTION 27 10 70 - COMMUNICATIONS TESTING, IDENTIFICATION AND ADMINISTRATION, this document describes the products and execution requirements relating to testing, labeling, warranties and As-Builts related to Communications Cabling Systems.
- E. SECTION 27 11 16 – COMMUNICATIONS CABINETS AND ENCLOSURES, this document describes the products and execution requirements relating to furnishing and installing Communication Equipment Room Fittings of cabinets, cable management, and telecommunications backboards are covered under this document.
- F. SECTION 27 13 23 – COMMUNICATIONS OPTICAL FIBER BACKBONE CABLING, this document describes the products and execution requirements relating to furnishing and installing Telecommunications Cabling Optical fiber backbone cabling and terminations are covered in this document.
- G. SECTION 27 15 00.19 – DATA COMMUNICATIONS HORIZONTAL CABLING, this document describes the products and execution requirements relating to furnishing and installing Horizontal Cabling. Data Communications Horizontal Cabling is covered under this document.
- H. SECTION 27 15 43 - COMMUNICATIONS FACEPLATES AND CONNECTORS, this document describes the products and execution requirements relating to furnishing and installing faceplates, connectors and

Category 5e and Category 6 patch cords. Communications faceplates and connectors are covered under this document.

1.2 WORK INCLUDED

- A. Provide all labor, materials, tools and equipment required for the complete installation of work called for in the Construction Documents

1.3 SCOPE OF WORK

- A. This document describes the products and execution requirements relating to furnishing and installing Structured Communications Cable System (SCCS) Category 6 patch panels and Category 5e patch panels are covered under this document.
- B. The MDF and/or IDF shall support a minimum of (2) 4-pair Unshielded Twisted Pair (UTP) Copper Cables to each work area outlet unless otherwise noted for specific locations. The cables shall be installed from the Work Area Outlet to the MDF or IDF located on the same floor, and routed to the appropriate enclosure serving that area and terminated as specified in this document.
- C. This section includes minimum requirements for the following:
 - 1. Patch panels
- D. All cables and related terminations, support and grounding hardware shall be furnished, installed, wired, tested, labeled, and documented by the telecommunications contractor as detailed in this document.
- E. Product specifications, general design considerations, and installation guidelines are provided in this document. Quantities of telecommunications outlets, typical installation details, cable routing and outlet types will be provided as an attachment to this document. If the bid documents are in conflict, this specification shall take precedence. The successful vendor shall meet or exceed all requirements for the cable system described in this document.
- F. The most recent versions of all documents apply to this project. If there is a conflict between applicable documents, the order above shall dictate the order of precedence in resolving the issue unless an enforceable local or national code is in effect.

1.4 SYSTEM CERTIFICATION AND/OR WARRANTY

- A. The installation must be certified to meet the latest available Systimax or AMP Netconnect manufacturer system warranty program requirements for an extended warranty of twenty (20) years minimum duration. At minimum such warranty shall, at no additional cost to LBUSD, provide a system warranty covering the installed Structured Telecommunications Cable against defects in workmanship, components and performance. At minimum, the contractors qualifications for manufacturer's certification shall include:
 - 1. SCCS Contractor shall be certified by the Manufacturer for a minimum of twelve (12) months prior to bid submittal date.

2. SCCS Contractor shall have valid Manufacturer Certification for the entire project duration of the installation agreement. In addition the SCCS Contractor shall have no known pending action or intent by Manufacturer and/or SCCS Contractor to terminate or limit the SCCS contractor status as a Manufacturer Certified installer.
 3. SCCS Contractor shall attach to bid response a copy of their current Manufacturer Certification certificate demonstrating valid certification in the Southern California region. The attached certificate is to specifically cite the name of proposing SCCS contractor.
- B. A SCCS Contractor installation warranty extending to the Structured Telecommunications Cable protecting LBUSD against defects in workmanship for a minimum period of two years from the date of system acceptance. Such warranty shall provide all labor and materials necessary to correct a failed portion of the system and to demonstrate performance within original specifications after the repairs are accomplished.
 - C. A system component and performance warranty extended by Systimax or AMP Netconnect for a period of not less than twenty (20) years from date of system acceptance. The performance warranty shall warrant the installed horizontal and backbone copper portion of the system and, as applicable, the installed horizontal and backbone fiber optic portions of the system. All such links and segments shall be warranted in accordance with the latest applicable requirements as defined by TIA/EIA.
 - D. As outlined herein, LBUSD intends that the resulting Structured Telecommunications Cable System be warranted under the extended warranty provisions extended by Systimax and AMP Netconnect. The Technical Specification is based on the products being manufactured by Systimax, AMP Netconnect and others. The warranty shall extend to the Category 5e and Category 6 UTP portions of the installation to the fullest extent allowed by the manufacturers.

1.5 DELIVERY AND STORAGE

- A. Provide protection from weather, moisture, dirt, dust and other contaminants for telecommunications cabling and pathway equipment placed in storage.

PART 2 - PRODUCTS

2.1 COMPONENTS

- A. UL or third party certified. Provide a complete system of telecommunications cabling and pathway components using star topology and support structures, pathways, and spaces complete with conduits, pull wires, raceways, pull boxes, outlets, cables, ground boxes, as per the drawings. Fixed cables and pathway systems for telecommunications systems shall be UL listed or third party independent testing laboratory certified, and shall comply with NFPA 70. Horizontal cable and termination equipment shall be of a manufacture, installed and certified so as to provide a minimum 20-year warranty.

2.2 HORIZONTAL CABLING TERMINATION PATCH PANELS

- A. UTP patch panels shall be rack mounted, rated to exceed EIA/TIA Category 5e modular (for existing campuses) and Category 6 modular (for new network installations) patch panels each wired to terminate modular jacks per the TIA T568C standard.
- B. Quantities of jacks are based on the number of UTP cables originating at wall outlets and terminating at the patch panel.
- C. Portable classrooms shall have Category 5e patch panels installed to support termination of OSP rated, Category 5e, UTP cable or Category 6 patch panels installed to support termination of OSP rated Category 6 cable.
- D. All patch panels shall be grounded.
- E. Manufacturer: Systimax or AMP Netconnect.

PART 3 - EXECUTION

3.1 INSTALLATION

- A. Cables shall be dressed and terminated in accordance with the recommendations made in the TIA/EIA-568-B standard, manufacturer's recommendations and best industry practices.
- B. Pair untwist at the termination shall not exceed 3.18 mm (0.125 inch).
- C. Bend radius of the cable in the termination area shall not exceed 4 times the outside diameter of the cable.
- D. Cables shall be neatly bundled and dressed to their respective panels or blocks. Each panel or block shall be fed by an individual bundle separated and dressed back to the point of cable entrance into the rack or frame.
- E. The cable jacket shall be maintained as close as possible to the termination point.
- F. Each cable shall be clearly labeled on the cable jacket behind the patch panel at a location that can be viewed without removing the bundle support ties. Cables labeled within the bundle, where the label is obscured from view shall not be acceptable.

3.2 HORIZONTAL CABLING TERMINATION PATCH PANELS

- A. Cables shall be dressed and terminated in accordance with the recommendations made in the TIA 568-C standards, manufacturer's recommendations and best industry practice.
- B. Pair untwist at the termination shall not exceed 3.18mm (0.125 inch).
- C. Bend radius of the cable in the termination area shall not exceed 4 times the outside diameter of the cable.
- D. Cables shall be neatly bundled and dressed to their respective panels or blocks. Each panel or block shall be fed by an individual bundle separated and dressed back to the point of cable entrance into the rack or frame.

- E. The cable jacket shall be maintained to within 25 mm (one inch) of the termination point.
- F. Each cable shall be clearly labeled on the cable jacket behind the patch panel at a location that can be viewed without removing the bundle support ties. Cables labeled within the bundle, where the label is obscured from view shall not be acceptable.

END OF SECTION



SECTION 27 13 23

COMMUNICATIONS OPTICAL FIBER BACKBONE CABLING

PART 1 - GENERAL

1.1 RELATED DOCUMENTS

- A. SECTION 27 05 05 - COMMON WORK RESULTS FOR COMMUNICATIONS, this document describes the LBUSD products, execution, qualifications, manufacturer warranties, and coordination requirements relating to furnishing and installing a complete, turn-key Communications Cabling System.
- B. SECTION 27 05 26 - GROUNDING AND BONDING FOR COMMUNICATIONS SYSTEMS, this document describes the products and execution requirements relating to furnishing and installing Grounding/Earthing and Bonding for Communications Systems.
- C. SECTION 27 05 28 – PATHWAYS FOR COMMUNICATIONS SYSTEMS, this document describes the products and execution requirements relating to furnishing and installing Telecommunications Cabling pathways. Communication cabling support is covered under this document.
- D. SECTION 27 10 70 - COMMUNICATIONS TESTING, IDENTIFICATION AND ADMINISTRATION, this document describes the products and execution requirements relating to testing, labeling, warranties and As-Builts related to Communications Cabling Systems.
- E. SECTION 27 11 16 – COMMUNICATIONS CABINETS AND ENCLOSURES, this document describes the products and execution requirements relating to furnishing and installing Communication Equipment Room Fittings of cabinets, cable management, and telecommunications backboards are covered under this document.
- F. SECTION 27 11 19 – COMMUNICATIONS PATCH PANELS, this document describes the products and execution requirements relating to furnishing and installing Structured Communications Cable System (SCCS) Category 5e and Category 6 patch panels are covered under this document.
- G. SECTION 27 15 00.19 – DATA COMMUNICATIONS HORIZONTAL CABLING, this document describes the products and execution requirements relating to furnishing and installing Horizontal Cabling. Data Communications Horizontal Cabling is covered under this document.
- H. SECTION 27 15 43 - COMMUNICATIONS FACEPLATES AND CONNECTORS, this document describes the products and execution requirements relating to furnishing and installing faceplates, connectors and Category 5e and Category 6 patch cords. Communications faceplates and connectors are covered under this document.

1.2 WORK INCLUDED

- A. Provide all labor, materials, tools and equipment required for the complete installation of work called for in the Construction Documents.

1.3 SCOPE OF WORK

- A. This document describes the products and execution requirements relating to furnishing and installing Telecommunications Cabling Optical fiber backbone cabling and terminations are covered in this document.
- B. This section includes minimum requirements for the following:
 1. Optical Fiber Backbone Cabling System
- C. All cables and related terminations and support hardware shall be furnished, installed, wired, tested, labeled, and documented by the telecommunications contractor as detailed in this document.
- D. Product specifications, general design considerations, and installation guidelines are provided in this document. Quantities of telecommunications outlets, typical installation details, cable routing and outlet types will be provided as an attachment to this document. If the bid documents are in conflict, this specification shall take precedence. The successful vendor shall meet or exceed all requirements for the cable system described in this document.

1.4 QUALITY ASSURANCE

- A. Corning Cable Systems LANscape 25 year Extended WarrantySM Program
 1. Installers shall offer LBUSD a 25-year warranty for LANscape® Fiber Optic Cabling Solutions and through the Corning Cable Systems LANscape Solutions Extended WarrantySM Program (EWP). The warranty covers specified LANscape Solutions product components including fiber optic cables, hardware, connectivity and preterminated systems.
- B. LANscape Network of Preferred Installers (NPI)
 1. A factory registered Corning Cable Systems LANscape NPI contractor shall complete network installation. The contractor shall have completed standards based product and installation training. A copy of the LANscape Network of Preferred Installers (NPI) certificate shall be submitted in the proposal.
- C. Product Guarantee
 1. Installers shall offer LBUSD a 25-year warranty for LANscape® Fiber Optic Cabling Solutions and through the Corning Cable Systems LANscape Solutions Extended WarrantySM Program (EWP). When installed per TIA or ISO/IEC standards, the LANscape® Fiber Optic Cabling Solution will operate the application(s) for which the system was designed to support. Applications may include, but are not limited to:
 - 10/100/1000 Mbps Ethernet (IEEE 802.3)
 - Gigabit Ethernet
 - 10 Gigabit Ethernet
- D. In order to qualify for the guarantee, the structured cabling system must be installed per

the following:

1. Meet all TIA/EIA commercial building wiring standards
2. Corning Cable Systems Products must be installed per Corning instruction sheets.

Note: All Networks shall be installed per applicable standards and manufacturer's guidelines.

1.5 APPROVED PRODUCTS

- A. Approved backbone fiber optic cable manufacturer: Corning
- B. Approved fiber optic patch cord manufacturer: Corning
- C. Approved fiber optic connector manufacturer: Corning
- D. Approved fiber optic enclosure manufacturer: Corning

PART 2 - PRODUCTS

2.1 EQUIVALENT PRODUCTS

- A. Corning shall manufacture all products, including but not limited to optical fiber backbone cabling (optical fiber splicing and terminations). There will be no substitutions allowed.

2.2 BACKBONE CABLING SYSTEM

- A. The Backbone Cable Subsystem in a building is the part of the premises distribution system that provides connection between equipment rooms, telecommunication rooms, and telecommunications service entrance facilities. A backbone subsystem provides either intra-building connections between floors in multi-story buildings or inter-building connections in campus-like environments.
- B. All cables shall be run using a star topology (home run) from the Main Cross-Connect (MC) to each Horizontal Cross-Connect (HC) within the telecommunications room. One additional Intermediate Cross-Connect (IC) may be implemented between the MC and HC if so required. The length of each individual run of backbone fiber cable shall not exceed 2000 meters for multimode and 3000 meters for singlemode as specified under TIA/EIA-568-B. The length of the media between the IC and HC shall not exceed 300 meters.
- C. The type of backbone fiber cable shall be 62.5/125 μm multimode fiber cable, 50/125 μm multimode fiber cable or 8.3/125 μm singlemode fiber cable. The bending radius and maximum pulling tension of the cable shall be adhered to during handling and installation.

2.3 GENERAL FIBER SPECIFICATIONS

- A. All fibers in the cable must be usable and meet required specifications.
- B. Each optical fiber shall be sufficiently free of surface imperfections and inclusions to meet the optical, mechanical, and environmental requirements of this specification.

- C. Each optical fiber shall consist of a germania-doped silica core surrounded by a concentric glass cladding. The fiber shall be a matched clad design, manufactured by the Outside Vapor Deposition (OVD) process.
- D. Each optical fiber shall be proof tested by the fiber manufacturer at a minimum of 100 kpsi (0.7 GN/m²).
- E. The fiber shall be coated with a dual layer acrylate protective coating. The coating shall be in physical contact with the cladding surface.
- F. The attenuation specification shall be a maximum value for each cabled fiber at 23 ± 5 °C on the original shipping reel.

2.4 MULTIMODE (62.5/125 µm OM1)

- A. The fiber shall meet the following specifications:
 1. EIA/TIA-492AAAA-A-1997, "Detail Specification for 62.5-µm Core Diameter/125-µm Cladding Diameter Class Ia Graded-Index Multimode Optical Fibers."
 2. IEC 60793-2-10, "Product specifications – Sectional specification for category A1 multimode fibres", Type A1b 62,5/125 µm graded index fibre.

Geometry		
2.1.1	Core Diameter (µm)	62.5 ± 2.5
2.1.2	Core Non-Circularity	≤ 5 %
2.1.3	Cladding Diameter (µm)	125.0 ± 2.0
2.1.4	Cladding Non-Circularity	≤ 1.0 %
2.1.5	Core-to-Cladding Concentricity (µm)	≤ 1.5
2.1.6	Coating Diameter (µm)	242 ± 5
2.1.7	Colored Fiber Nominal Diameter (µm)	253 - 259

Optical		
2.1.8	Cabled Fiber Attenuation (dB/km) 850 nm 1300 nm	≤ 3.4 ≤ 1.0
2.1.9	Point Discontinuity (dB) 850 nm 1300 nm	≤ 0.2 ≤ 0.2
2.1.10	Macrobend Attenuation (dB) <u>Turns</u> <u>Mandrel OD</u> 100 75 ± 2 mm 100 75 ± 2 mm	≤ 0.5 at 850 nm ≤ 0.5 at 1300 nm
2.1.11	Cabled Effective Modal Bandwidth ¹⁾ (MHz•km) 850 nm	≥ 220
2.1.12	IEEE 802.3 GbE Distance (m) 1000BASE-SX Window (850 nm) 1000BASE-LX Window (1300 nm)	up to 300 up to 550

2.1.13	OFL Bandwidth 850 nm 1300 nm	(MHz•km) ≥ 200 ≥ 500
2.1.14	Numerical Aperture	0.275 ± 0.015

1) As predicted by RML BW, per TIA/EIA 455-204 and IEC 60793-1-41, for *intermediate performance laser based systems* (up to 1 Gb/s).

B. FREEDM® One Tight-Buffered, Interlocking Armored Cable, Plenum 12 F, 62.5/125 µm multimode (OM1)

1. Interlocking Armored Cables shall be flame-retardant, indoor/outdoor, cables designed for inter-building and intra-building back-bone installations that eliminate the need for a transition splice when entering the building.
2. Interlocking Armored Cables shall be encased in a spirally wrapped, aluminum interlocking armor
3. Interlocking Armored Cables shall be protected against water penetration by water-blocking technology, rated for OSP applications.
4. Interlocking Armored Cables shall be available in 12 different jacket colors - blue, orange, green, brown, slate, white, red, black, yellow, purple, rose and aqua. Black is the standard jacket color using the standard part numbers shown here. Contact Customer Care at 1-800-743-2675 to order other color options.

- Part Number: 012K8P-31130-A3

2.5 MULTIMODE (50/125 µm)

A. Laser-optimized 50/125 µm Fiber – 550 (OM4)

1. The fiber shall meet the requirements of EIA/TIA-492AAAD, "Detail Specification for 850- nm Laser-Optimized, 50-µm Core Diameter/125-µm Cladding Diameter Class Ia.
2. Graded-Index Multimode Optical Fibers Suitable for Manufacturing OM4 Cabled Optical Fiber."
3. The fiber shall have the same specified performance and geometry values as standard 50/125 µm fiber (section 3.1) except as noted below.

2.4.1	Cabled Fiber Attenuation 850 nm 1300 nm	≤ 2.8 dB/km ≤ 1.0 dB/km
2.4.2	Cabled Effective Modal Bandwidth ¹⁾ 850 nm	≥ 4700 MHz•km
2.4.2	IEEE 802.3 GbE Distance 1000BASE-SX Window (850 nm) 1000BASE-LX Window (1300 nm)	up to 1100 m up to 600 m
2.4.2	IEEE 802.3 10 GbE Distance 10GBASE-S Window (850 nm)	up to 550 m
2.4.2	OFL Bandwidth 850 nm 1300 nm	≥ 3500 MHz•km ≥ 500 MHz•km

1) As predicted by minEMBc, per TIA/EIA 455-220 and IEC 60793-1-49, for *high*

performance laser-based systems (up to 10 Gb/s).

2. Multimode optical fiber performances referenced in this specification.

Fiber Type	Maximum Attenuation 850/1300 nm (dB/km)	Minimum OFL BW 850/1300 nm (MHz•km)	Minimum Effective Modal BW 850 nm (MHz•km)	1 GbE Distance 850/1300 nm (meters)	10 GbE Distance 850 nm (meters)
50/125 µm Laser-optimized - 550	2.8/1.0	3500/500	≥ 4700	1100/600 ¹⁾	550 ³⁾

- 1) Guaranteed distance for Gigabit Ethernet compliant systems.
- 2) Guaranteed distance for 10 Gigabit Ethernet compliant systems.
- 3) The 550m distance is equivalent to a 4700 EMB system with standards-compliant transceiver and fiber characteristics, 3.0 dB/km cable attenuation, and 1.0 dB total connector loss.
- 4) The 500m distance is equivalent to a 5350 EMB system with standards-compliant transceiver and fiber characteristics, 3.0 dB/km cable attenuation, and 1.0 dB total connector loss.

B. FREEDM® One Tight-Buffered, Interlocking Armored Cable, Plenum 12 F, 50 µm multimode (OM4)

5. Interlocking Armored Cables shall be flame-retardant, indoor/outdoor, cables designed for inter-building and intra-building back-bone installations that eliminate the need for a transition splice when entering the building.
6. Interlocking Armored Cables shall be encased in a spirally wrapped, aluminum interlocking armor
7. Interlocking Armored Cables shall be protected against water penetration by water-blocking technology, rated for OSP applications.
8. Interlocking Armored Cables shall be available in 12 different jacket colors - blue, orange, green, brown, slate, white, red, black, yellow, purple, rose and aqua. Black is the standard jacket color using the standard part numbers shown here. Contact Customer Care at 1-800-743-2675 to order other color options.
 - Part Number: 024T8P-31190-A3

2.6 SINGLE-MODE BEND IMPROVED OPTICAL FIBER

- A. The single-mode Low Water Peak fiber utilized in the optical fiber cable shall meet EIA/TIA- 492CAAB, "Detail Specification for Class IVa Dispersion-Unshifted Single-Mode Optical Fibers with Low Water Peak," and ITU-T G.652.D "Characteristics of a single-mode optical fiber cable," and ITU-T G.657, Table A, "Characteristics of a Bending Loss Insensitive Single Mode Optical Fiber for Access Networks."

Geometry		
3.1	Cladding Diameter	(µm) 125.0 ± 0.7

3.2	Core-to-Cladding Concentricity	(μm)	≤ 0.5
3.3	Cladding Non-Circularity		$\leq 0.7\%$
3.4	Mode Field Diameter	(μm) 1310 nm 1550 nm	8.6 \pm 0.4 9.8 \pm 0.5
3.5	Coating Diameter	(μm)	245 \pm 5
3.6	Colored Fiber Nominal Diameter	(μm)	249 - 259
3.7	Fiber Curl radius of curvature	(m)	≥ 4.0 m

Optical			
3.8	Cabled Fiber Attenuation	(dB/km) 1310 nm 1383 \pm 3 nm 1550 nm	≤ 0.65 ≤ 0.65 ≤ 0.5
3.9	Point discontinuity	(dB) 1310 nm 1550 nm	≤ 0.05 ≤ 0.05
3.10	Macrobend Attenuation	(dB) <u>Turns</u> <u>Mandrel OD</u> 1 20 \pm 2 mm 1 20 \pm 2 mm 10 30 \pm 2 mm 100 60 \pm 2 mm	< 1.5 at 1625 nm ≤ 0.50 at 1550 nm ≤ 0.05 at 1550 nm ≤ 0.01 at 1625 nm
3.11	Cable Cutoff Wavelength (λ_{ccf})	(nm)	≤ 1260
3.12	Zero Dispersion Wavelength (λ_0)	(nm)	1302 $\leq \lambda_0 \leq 1322$
3.13	Zero Dispersion Slope (S_0)	(ps/(nm ² •km))	≤ 0.089
3.14	Total Dispersion	(ps/(nm•km)) 1285-1330 nm 1550 nm 1625 nm	≤ 3.5 ≤ 17.4 ≤ 21.3
3.15	Cabled Polarization Mode Dispersion (ps km)		≤ 0.2
3.16	IEEE 802.3 GbE - 1300 nm Laser Distance (m)		up to 5000
3.17	Water Peak Attenuation: 1383 \pm 3 nm (dB/km)		≤ 0.65

B. FREEDM® One Tight-Buffered, Interlocking Armored Cable, Plenum 12 F, Single-mode (OS2).

1. Interlocking Armored Cables shall be flame-retardant, indoor/outdoor, cables designed for inter-building and intra-building back- bone installations that eliminate the need for a transition splice when entering the building.
2. Interlocking Armored Cables shall be encased in a spirally wrapped, aluminum interlocking armor
3. Interlocking Armored Cables shall be protected against water penetration by water-blocking technology, rated for OSP applications.

4. Interlocking Armored Cables shall be available in 12 different jacket colors - blue, orange, green, brown, slate, white, red, black, yellow, purple, rose and aqua. Black is the standard jacket color using the standard part numbers shown here. Contact Customer Care at 1-800-743-2675 to order other color options.

- Part Number: 012E8P-31131-A3

2.7 FIBER OPTIC CONNECTORS

- A. Fiber optic connectors shall be Field Polished.
- B. Fiber optic connectors shall be type LC.
- C. Fiber optic connectors shall have ceramic ferrule.
- D. Fiber optic connector installation shall be with Anaerobic-Cure, two-part epoxy process.
- E. Fiber optic connectors for multimode fiber shall be performance category rated for 50 μ m multimode (OM4/OM4 extended 10G distance).
- F. Fiber optic connectors for multimode fiber shall have black housing and aqua boot.
- G. Fiber optic connectors for singlemode fiber shall be performance category rated for singlemode (OS2).
- H. Fiber optic connectors for singlemode shall have blue housing and blue boot.
- I. Fiber optic connectors shall be manufactured by Corning.
 1. Multimode Connector Part Number: 95-051-98-SP-X
 2. Singlemode Connector Part Number: 95-201-98-SP

2.8 FIBER OPTIC PATCH CORDS

- A. Fiber Optic Patch Cables shall be multimode patch cords or where required, singlemode, pre-made to connect fiber optic equipment with fiber optic cross connects, interconnects and outlets.
- B. The patch cords (jumpers) shall be impact-resistant, duplex fiber cables with LC to LC connectors, of the same performance characteristics as the multimode or singlemode fiber backbone being connected.
- C. These fiber optic patch panel connections shall provide 0.4 dB or less insertion loss and provide connection between the Active LAN devices and the Fiber Optic patch panel. Quantities for 100% fiber strand population at both ends plus 10% Spares.
- D. Unless otherwise stated in the RFQ, the Structured Telecommunications Cable Contractor shall deliver:
 1. IDF Patch Cords – 2 Meter in length, LC - LC connectorized, multimode, duplex, fiber optic patch cord.
 2. MDF Patch Cords – 2 Meter in length, LC - LC connectorized, multimode, duplex, fiber optic patch cord.
 3. IDF Patch Cords – 2 Meter in length, LC - LC connectorized, singlemode, duplex, fiber optic patch cord.

4. MDF Patch Cords – 2 Meter in length, LC - LC connectorized, singlemode, duplex, fiber optic patch cord.

G. Manufacturer: Corning.

2.9 FIBER OPTIC PATCH PANELS

- A. Provide panel for maintenance and cross connecting of fiber optic cables.
- B. Panel shall have connector panels which interface the fiber optic patch cords with the fiber optic backbone cable.
- C. Panels shall be equipped with engraved laminated plastic nameplates above each connector.
- D. Rack-mounted fiber patch panels shall be equipped to terminate or splice the incoming inter-building fiber and any required backbone or interconnect cables.
- E. Each cable must be properly dressed.
- F. These units will terminate the fiber optic cables, provide a place for jumper cables and will provide room to terminate additional optics.
- G. MDF panels shall provide capacity to support terminations of all incoming IDF fiber optic backbone cables.
- H. IDF panels shall provide capacity for minimum of 12 fiber optic strands. Larger capacity patch panels shall be determined at site walk.
- I. Panel shall be 100% populated with type LC couplers and adapter plates.
- J. All connectors and couplers will be type LC.
- K. The fiber optic patch panel connections shall provide 0.4 dB or less insertion loss.
- L. All patch panels shall be grounded.
- M. Manufacturer: Corning.

PART 3 - EXECUTION

3.1 INSTALLATION

- A. Telecommunications cabling and pathway systems, including the horizontal and backbone cable, pathway systems, telecommunications outlet/connector assemblies, and associated hardware shall be installed in accordance with TIA-568-B.1, B.2, B.3, TIA-569-A, NFPA 70, and UL standards as applicable.
- B. Cabling shall be connected in a star topology network.
- C. Contractor shall provide all necessary tools and materials not specified, (tie wraps, “d” rings, screws, consumables, hardware, etc.) and equipment, (ladders, hydraulic lifts, storage containers, etc.) necessary to provide a complete and operating system.
- D. Installation methodologies shall adhere to manufacturer installation procedures so as to not violate certifications (i.e. UL).
- E. All work shall be performed in a good workmanship-like manner leaving each location in the same or better condition as at the start of each project.

- F. The designated District representative shall be provided progress reports.
- G. Periodic on-site inspections will be done during the course of installation.
- H. The District reserves the right of "local jurisdiction" for final approval.

3.2 BACKBONE CABLE

- A. Use only where specifically indicated on plans or determined during site surveys.
- B. When not run in surface mounted raceway or conduit, utilize non-continuous cable support above suspended ceilings and in all ceiling spaces.
- C. Comply with TIA-568-B.1 and B.2.
- D. Install cabling above suspended ceilings 6 to 12 inches above ceiling T-bar using non-continuous cable support spaced on 24 to 48 inch centers and securely attached to structural ceiling.
- E. Do not exceed cable pull tensions recommended by the manufacturer.
- F. Plenum cable shall be used in all areas. Plenum cables shall comply with flammability plenum requirements of NFPA 70 and shall comply with UL 910.
- G. Cables shall be placed in the non-continuous cable support located every 2 to 4 feet, as long as they are separately bundled and tie-wrapped using Velcro ties.
- H. Cabling shall be organized and identified so as to facilitate locating and handling individual sheaths for maintenance functions.
- I. Each bundle shall be neatly tied without over cinching or stressing cable.
- J. Bundles shall be clearly marked identifying the MDF and IDF to which routed, and any other information that may assist in administration.
- K. Great care shall be taken to protect all cabling from physical damage.
- L. A 20' service loop shall be installed above ceiling on each cable installation where possible.
- M. Fiber Optic Backbone Cable. Install Indoor/Outdoor, plenum rated, armored fiber optic backbone (OFNP) in pathways.
- N. Do not exceed manufacturer's recommended bending radii and pull tension.
- O. Prepare cable for pulling by cutting outer jacket 10 inches leaving strength members exposed for approximately 10 inches. Twist strength members together and attach to pulling eye.
- P. Terminate individual strands into fiber optic type LC connectors.

END



SECTION 27 15 00.19

DATA COMMUNICATIONS HORIZONTAL CABLING

PART 1 - GENERAL

1.1 RELATED DOCUMENTS

- A. SECTION 27 05 05 - COMMON WORK RESULTS FOR COMMUNICATIONS, this document describes the LBUSD products, execution, qualifications, manufacturer warranties, and coordination requirements relating to furnishing and installing a complete, turn-key Communications Cabling System.
- B. SECTION 27 05 26 - GROUNDING AND BONDING FOR COMMUNICATIONS SYSTEMS, this document describes the products and execution requirements relating to furnishing and installing Grounding/Earthing and Bonding for Communications Systems.
- C. SECTION 27 05 28 – PATHWAYS FOR COMMUNICATIONS SYSTEMS, this document describes the products and execution requirements relating to furnishing and installing Telecommunications Cabling pathways. Communication cabling support is covered under this document.
- D. SECTION 27 10 70 - COMMUNICATIONS TESTING, IDENTIFICATION AND ADMINISTRATION, this document describes the products and execution requirements relating to testing, labeling, warranties and As-Builts related to Communications Cabling Systems.
- E. SECTION 27 11 16 – COMMUNICATIONS CABINETS AND ENCLOSURES, this document describes the products and execution requirements relating to furnishing and installing Communication Equipment Room Fittings of cabinets, cable management, and telecommunications backboards are covered under this document.
- F. SECTION 27 11 19 – COMMUNICATIONS PATCH PANELS, this document describes the products and execution requirements relating to furnishing and installing Structured Communications Cable System (SCCS) Category 5e and Category 6 patch panels are covered under this document.
- G. SECTION 27 13 23 – COMMUNICATIONS OPTICAL FIBER BACKBONE CABLING, this document describes the products and execution requirements relating to furnishing and installing Telecommunications Cabling Optical fiber backbone cabling and terminations are covered in this document.
- H. SECTION 27 15 43 - COMMUNICATIONS FACEPLATES AND CONNECTORS, this document describes the products and execution requirements relating to furnishing and installing faceplates, connectors, Category 5e and Category 6 patch cords. Communications faceplates and connectors are covered under this document.

1.2 WORK INCLUDED

- A. Provide all labor, materials, tools and equipment required for the complete installation of work called for in the Construction Documents

1.3 SCOPE OF WORK

- A. This document describes the products and execution requirements relating to furnishing and installing Horizontal Cabling. Data Communications Horizontal Cabling is covered under this document.
- B. The Communication Equipment Room shall support a minimum of (2) 4-pair Unshielded Twisted Pair (UTP) Copper Cables to each work area outlet unless otherwise noted for specific locations. The cables shall be installed from the Work Area Outlet to the Telecommunications Room (TR) located on the same floor, and routed to the appropriate rack serving that area and terminated as specified in this document.
- C. This section includes minimum requirements for the following:
 - Copper UTP Cable
- D. All cables and related terminations, support and grounding hardware shall be furnished, installed, wired, tested, labeled, and documented by the telecommunications contractor as detailed in this document.
- E. Product specifications, general design considerations, and installation guidelines are provided in this document. Quantities of telecommunications outlets, typical installation details, cable routing and outlet types will be provided as an attachment to this document. If the bid documents are in conflict, this specification shall take precedence. The successful vendor shall meet or exceed all requirements for the cable system described in this document.

1.4 SYSTEM CERTIFICATION AND/OR WARRANTY

- A. The installation must be certified to meet the latest available Systimax or AMP Netconnect manufacturer system warranty program requirements for an extended warranty of twenty (20) years minimum duration. At minimum such warranty shall, at no additional cost to LBUSD, provide a system warranty covering the installed Structured Telecommunications Cable against defects in workmanship, components and performance. At minimum, the contractors qualifications for manufacturer's certification shall include:
 - 1. SCCS Contractor shall be certified by the Manufacturer for a minimum of twelve (12) months prior to bid submittal date.
 - 2. SCCS Contractor shall have valid Manufacturer Certification for the entire project duration of the installation agreement. In addition the SCCS Contractor shall have no known pending action or intent by Manufacturer and/or SCCS Contractor to terminate or limit the SCCS contractor status as a Manufacturer Certified installer.
 - 3. SCCS Contractor shall attach to bid response a copy of their current Manufacturer Certification certificate demonstrating valid certification in the

Southern California region. The attached certificate is to specifically cite the name of proposing SCCS contractor.

- B. A SCCS Contractor installation warranty extending to the Structured Telecommunications Cable protecting LBUSD against defects in workmanship for a minimum period of two years from the date of system acceptance. Such warranty shall provide all labor and materials necessary to correct a failed portion of the system and to demonstrate performance within original specifications after the repairs are accomplished.
- C. A system component and performance warranty extended by Systimax or AMP Netconnect for a period of not less than twenty (20) years from date of system acceptance. The performance warranty shall warrant the installed horizontal and backbone copper portion of the system and, as applicable, the installed horizontal and backbone fiber optic portions of the system. All such links and segments shall be warranted in accordance with the latest applicable requirements as defined by TIA/EIA.
- D. As outlined herein, LBUSD intends that the resulting Structured Telecommunications Cable System be warranted under the extended warranty provisions extended by Systimax and AMP Netconnect. The Technical Specification is based on the products being manufactured by Systimax, AMP Netconnect and others. The warranty shall extend Category 5e and Category 6 UTP portions of the installation to the fullest extent allowed by the manufacturers.

1.5 DELIVERY AND STORAGE

- A. Provide protection from weather, moisture, dirt, dust and other contaminants for telecommunications cabling and pathway equipment placed in storage.

PART 2 - PRODUCTS

2.1 COMPONENTS

- A. UL or third party certified. Provide a complete system of telecommunications cabling and pathway components using star topology and support structures, pathways, and spaces complete with conduits, pull wires, raceways, pull boxes, outlets, cables, ground boxes, as per the drawings. Fixed cables and pathway systems for telecommunications systems shall be UL listed or third party independent testing laboratory certified, and shall comply with NFPA 70. Horizontal cable and termination equipment shall be of a manufacture, installed and certified so as to provide a minimum 20-year warranty.

2.2 PATHWAYS (HORIZONTAL)

- A. TIA/EIA-569-A. Pathway shall be conduit, and nonmetallic surface mounted raceway installations. Provide grounding and bonding as required by ANSI/J-STD-607-A.
- B. Pathways shall be installed in accordance with NEC Article 314 and Article 800.51 (J), (K), or (L), as applicable, and installed in accordance with Articles 362.24 through 362.56, where the requirements applicable to electrical nonmetallic tubing apply.

2.3 TELECOMMUNICATIONS CABLING

- A. Cabling shall be UL listed for the application and shall comply with TIA/EIA-568-C.1, C.2 and NFPA 70. Cabling shall consist of Category 5e (for existing networks), Category 6 UTP (for new networks). Plenum rated cables shall comply with UL 910. Provide a labeling system for cabling as required by TIA/EIA-606-A and UL 969. Cabling manufactured more than 12 months prior to date of installation shall not be used.

2.4 HORIZONTAL CABLING

- A. Shall consist of plenum rated Category 5e (for existing permanent networks), OSP rated Category 5e (for existing networks in portable classroom buildings), plenum rated Category 6 UTP (for new permanent networks) and OSP rated Category 6 (for new networks in portable classroom buildings)
- B. Comply with NFPA 70, NEMA WC 63, ANSI/ICEA S-80-576 and performance characteristics in TIA/EIA-568-C.1 and C.2 UTP, four-pair 100 ohm.
- C. Category 6 cable shall provide four individually twisted pairs, 23 AWG or 22 AWG conductors enclosed by an overall plenum-rated jacket.
- D. Individual pairs shall be constructed to contain minimum two twists per foot per each pair.
- E. Ultimate breaking strength shall be minimum 90 pounds.
- F. Four pair cable shall withstand a bend radius of one-inch minimum at a temperature of minus 20 degrees C maximum without jacket or insulation cracking.
- G. Conductors shall be color coded and polarized in accordance with TIA/EIA-568-C.1 and C.2.
- H. Plenum rated Category 5e and Category 6 UTP plenum and OSP rated cable for local area networks shall exceed TIA/EIA-568-C.1 and C.2 standards.
- I. Conductor shall be 24, 23, or 22 AWG solid annealed copper.
- J. Plenum rated cable shall comply with NFPA 70, UL 444, and UL 910.
- K. Plenum rated cable jacket shall be blue in color.
- L. Portable classrooms with existing networks shall have OSP rated, Category 5e, UTP cable installed.
- M. Portable classrooms with new networks shall have OSP rated, Category 6, UTP cable installed.
- N. Manufacturer: Systimax, AMP Netconnect and CommScope for OSP rated Category 5e cable and Category 6 cable.

PART 3 - EXECUTION

3.1 HORIZONTAL DISTRIBUTION CABLE INSTALLATION

- A. Cable shall be installed in accordance with manufacturer's recommendations and best industry practices.
- B. A pull cord (nylon; 1/8" minimum) shall be co-installed with all cable installed in any conduit.
- C. Cable raceways shall not be filled greater than the TIA/EIA-569-A maximum fill for the particular raceway type or 40%.
- D. Cables shall be installed in continuous lengths from origin to destination (no splices) except for transition points, or consolidation points.
- E. Where transition points, or consolidation points are allowed, they shall be located in accessible locations and housed in an enclosure intended and suitable for the purpose.
- F. The cable's minimum bend radius and maximum pulling tension shall not be exceeded.
- G. If a J-hook or trapeze system is used to support cable bundles all horizontal cables shall be supported at a maximum of 48 to 60 inch (1.2 to 1.5 meter) intervals. At no point shall cable(s) rest on acoustic ceiling grids or panels.
- H. Horizontal distribution cables shall be bundled in groups of no more than 50 cables. Cable bundle quantities in excess of 50 cables may cause deformation of the bottom cables within the bundle and degrade cable performance.
- I. Cable shall be installed above fire-sprinkler systems and shall not be attached to the system or any ancillary equipment or hardware. The cable system and support hardware shall be installed so that it does not obscure any valves, fire alarm conduit, boxes, or other control devices.
- J. Cables shall not be attached to ceiling grid or lighting fixture wires. Where support for horizontal cable is required, the contractor shall install appropriate carriers to support the cabling.
- K. Any cable damaged or exceeding recommended installation parameters during installation shall be replaced by the contractor prior to final acceptance at no cost to the Owner.
- L. Cables shall be identified by a self-adhesive label in accordance with the System Documentation Section of this specification and ANSI/TIA/EIA-606. The cable label shall be applied to the cable behind the faceplate on a section of cable that can be accessed by removing the cover plate.
- M. Unshielded twisted pair cable shall be installed so that there are no bends smaller than four times the cable outside diameter at any point in the run and at the termination field.
- N. Pulling tension on 4-pair UTP cables shall not exceed 25-lbf for a four-pair UTP cable.

3.2 HORIZONTAL CROSS CONNECT INSTALLATION

- A. Cables shall be dressed and terminated in accordance with the recommendations made in the TIA/EIA-568-C standard, manufacturer's recommendations and best industry practices.
- B. Pair untwist at the termination shall not exceed 3.18 mm (0.125 inch).
- C. Bend radius of the cable in the termination area shall not exceed 4 times the outside diameter of the cable.
- D. Cables shall be neatly bundled and dressed to their respective panels or blocks. Each panel or block shall be fed by an individual bundle separated and dressed back to the point of cable entrance into the rack or frame.
- E. The cable jacket shall be maintained as close as possible to the termination point.
- F. Each cable shall be clearly labeled on the cable jacket behind the patch panel at a location that can be viewed without removing the bundle support ties. Cables labeled within the bundle, where the label is obscured from view shall not be acceptable.

END OF SECTION



SECTION 27 15 43

COMMUNICATIONS FACEPLATES AND CONNECTORS

PART 1 - GENERAL

1.1 RELATED DOCUMENTS

- A. SECTION 27 05 05 - COMMON WORK RESULTS FOR COMMUNICATIONS, this document describes the LBUSD products, execution, qualifications, manufacturer warranties, and coordination requirements relating to furnishing and installing a complete, turn-key Communications Cabling System.
- B. SECTION 27 05 26 - GROUNDING AND BONDING FOR COMMUNICATIONS SYSTEMS, this document describes the products and execution requirements relating to furnishing and installing Grounding/Earthing and Bonding for Communications Systems.
- C. SECTION 27 05 28 – PATHWAYS FOR COMMUNICATIONS SYSTEMS, this document describes the products and execution requirements relating to furnishing and installing Telecommunications Cabling pathways. Communication cabling support is covered under this document.
- D. SECTION 27 10 70 - COMMUNICATIONS TESTING, IDENTIFICATION AND ADMINISTRATION, this document describes the products and execution requirements relating to testing, labeling, warranties and As-Builts related to Communications Cabling Systems.
- E. SECTION 27 11 16 – COMMUNICATIONS CABINETS AND ENCLOSURES, this document describes the products and execution requirements relating to furnishing and installing Communication Equipment Room Fittings of cabinets, cable management, and telecommunications backboards are covered under this document.
- F. SECTION 27 11 19 – COMMUNICATIONS PATCH PANELS, this document describes the products and execution requirements relating to furnishing and installing Structured Communications Cable System (SCCS) Category 5e and Category 6 patch panels are covered under this document.
- G. SECTION 27 13 23 – COMMUNICATIONS OPTICAL FIBER BACKBONE CABLING, this document describes the products and execution requirements relating to furnishing and installing Telecommunications Cabling Optical fiber backbone cabling and terminations are covered in this document.
- H. SECTION 27 15 00.19 – DATA COMMUNICATIONS HORIZONTAL CABLING, this document describes the products and execution requirements

relating to furnishing and installing Horizontal Cabling. Data Communications Horizontal Cabling is covered under this document.

1.2 WORK INCLUDED

- A. Provide all labor, materials, tools and equipment required for the complete installation of work called for in the Construction Documents.

1.3 SCOPE OF WORK

- A. This document describes the products and execution requirements relating to furnishing and installing faceplates and connectors. Communications faceplates and connectors are covered under this document.
- B. The Communication Equipment Room shall support a minimum of (2) 4-pair Unshielded Twisted Pair (UTP) Copper Cables to each work area outlet unless otherwise noted for specific locations. The cables shall be installed from the Work Area Outlet to the MDF or located on the same floor, and routed to the appropriate rack serving that area and terminated as specified in this document.
- C. This section includes minimum requirements for the following:
 - 1. Faceplates
 - 2. Copper patch cords
 - 3. Modular connectors
- D. All cables and related terminations, support and grounding hardware shall be furnished, installed, wired, tested, labeled, and documented by the telecommunications contractor as detailed in this document.
- E. Product specifications, general design considerations, and installation guidelines are provided in this document. Quantities of telecommunications outlets, typical installation details, cable routing and outlet types will be provided as an attachment to this document. If the bid documents are in conflict, this specification shall take precedence. The successful vendor shall meet or exceed all requirements for the cable system described in this document.

1.4 SYSTEM CERTIFICATION AND/OR WARRANTY

- A. The installation must be certified to meet the latest available Systemax or AMP Netconnect manufacturer system warranty program requirements for an extended warranty of twenty (20) years minimum duration. At minimum such warranty shall, at no additional cost to LBUSD, provide a system warranty covering the installed Structured Telecommunications Cable against defects in workmanship, components and performance. At minimum, the contractors qualifications for manufacturer's certification shall include:
 - 1. SCCS Contractor shall be certified by the Manufacturer for a minimum of twelve (12) months prior to bid submittal date.
 - 2. SCCS Contractor shall have valid Manufacturer Certification for the entire project duration of the installation agreement. In addition the

SCCS Contractor shall have no known pending action or intent by Manufacturer and/or SCCS Contractor to terminate or limit the SCCS contractor status as a Manufacturer Certified installer.

3. SCCS Contractor shall attach to bid response a copy of their current Manufacturer Certification certificate demonstrating valid certification in the Southern California region. The attached certificate is to specifically cite the name of proposing SCCS contractor.
- B. A SCCS Contractor installation warranty extending to the Structured Telecommunications Cable protecting LBUSD against defects in workmanship for a minimum period of two years from the date of system acceptance. Such warranty shall provide all labor and materials necessary to correct a failed portion of the system and to demonstrate performance within original specifications after the repairs are accomplished.
 - C. A system component and performance warranty extended by Systimax or AMP Netconnect for a period of not less than twenty (20) years from date of system acceptance. The performance warranty shall warrant the installed horizontal and backbone copper portion of the system and, as applicable, the installed horizontal and backbone fiber optic portions of the system. All such links and segments shall be warranted in accordance with the latest applicable requirements as defined by TIA/EIA.
 - D. As outlined herein, LBUSD intends that the resulting Structured Telecommunications Cable System be warranted under the extended warranty provisions extended by Systimax and AMP Netconnect. The Technical Specification is based on the products being manufactured by Systimax, AMP Netconnect and others. The warranty shall extend to the Category 5e and Category 6 UTP portions of the installation to the fullest extent allowed by the manufacturers.

1.5 DELIVERY AND STORAGE

- A. Provide protection from weather, moisture, dirt, dust and other contaminants for telecommunications cabling and pathway equipment placed in storage.

PART 2 - PRODUCTS

2.1 COMPONENTS

- A. UL or third party certified. Provide a complete system of telecommunications cabling and pathway components using star topology and support structures, pathways, and spaces complete with conduits, pull wires, raceways, pull boxes, outlets, cables, ground boxes, as per the drawings. Fixed cables and pathway systems for telecommunications systems shall be UL listed or third party independent testing laboratory certified, and shall comply with NFPA 70. Horizontal cable and termination equipment shall be of a manufacture, installed and certified so as to provide a minimum 20-year warranty.

2.2 TELECOMMUNICATIONS OUTLET/CONNECTOR ASSEMBLIES

- A. Jacks shall comply with FCC Part 68.5, and TIA/EIA-568-C.1 and C.2.

- B. Jacks shall accommodate UTP or OFNR and work in concert with Wiremold 5500 raceway.
- C. UTP jacks shall be RJ-45 designation T568B type, UL 1863 listed, eight position, constructed of high impact rated thermoplastic housing rated for Category 5e (for existing networks) and Category 6 (for new networks) service.
- D. UTP jacks for data shall be Category 5e (for existing networks) and Category 6 (for new networks) hardware and shall comply with the attenuation requirements contained in TIA/EIA-568-C.1 and C.2.
- E. Jacks shall be blue in color.
- F. Telecommunications face plates shall comply with UL 514C, and TIA/EIA-568-C.1 and C.2; flush design constructed of high impact thermoplastic material.
- G. Telecommunications faceplate colors shall be coordinated with LBUSD or as noted on drawings.
- H. Telecommunications faceplates shall be available in 2-port, 4-port and 6-port single-gang configurations and as designated by LBUSD at site survey or as noted on drawings.
- I. Telecommunications faceplates shall have the following characteristics.
 - 1. Be UL listed and CSA certified.
 - 2. Be from the same manufacturer as modular jacks.
 - 3. Be constructed of high impact, ABS plastic UL 94V0-0 construction UON.
 - 4. Match the faceplate color used for other utilities in the building.
 - 5. Be available as single-gang or dual-gang.
 - 6. Be two - six-port configuration.
 - 7. Possess recessed designation windows to facilitate labeling and identification.
 - 8. Have mounting screws located under recessed designation windows.
 - 9. Allow for UTP modules to be inverted in place for termination purposes.
 - 10. Faceplate color to be coordinated with LBUSD.
- J. All unused faceplate openings shall have blanks installed.
- K. Stenciled lettering for voice and data circuits shall be provided using thermal ink transfer process.
- L. Manufacturer: Systimax or AMP Netconnect.

PART 3 - EXECUTION

3.1 COPPER TERMINATION HARDWARE

- A. Cables shall be dressed and terminated in accordance with the recommendations made in the ANSI/TIA/EIA-568-C standards, manufacturer's recommendations and best industry practice.
- B. Pair untwist at the termination shall not exceed 3.18mm (0.125 inch).
- C. Bend radius of the cable in the termination area shall not exceed 4 times the outside diameter of the cable.
- D. The cable jacket shall be maintained to within 25 mm (one inch) of the termination point.
- E. Each cable shall be clearly labeled on the cable jacket behind the patch panel at a location that can be viewed without removing the bundle support ties. Cables labeled within the bundle, where the label is obscured from view shall not be acceptable.

3.2 HORIZONTAL CABLING

- A. Install horizontal cabling and pathway as shown on drawings or as determined at site survey, between MDF, IDF and telecommunications outlet assemblies at workstations, in accordance with TIA/EIA-568-C.1, C.2 and 569-A.

3.3 WORK AREA OUTLETS

- A. Terminate UTP cable in accordance with TIA/EIA-568-C.1, C.2 and wiring configuration T568B.

3.2 PATCH CABLE REQUIREMENT

- A. Category 5e and Category 6 patch cables are to be included in any quote provided to the district for cabling installations at schools and offices. Sufficient patch cables to populate 100% of the installation, plus 10% spares are required.
- B. Unless otherwise stated in the RFQ, the contractor will deliver:
 - 1. IDF (Copper) – 3 feet in length, Cat 5e or Cat 6 Certified. Color shall be Red.
 - 2. Station Cables to attach computers to network (Copper) – 10 feet in length, Cat 5 or Cat 6 Certified. Color shall be Blue.

END OF SECTION